

<b>Noname manuscript No.</b> (will be inserted by the editor)
------------------------------------------------------------------

---

## Sanction or Financial Crisis?

### An Artificial Neural Network-Based Approach to model the impact of oil price volatility on Stock and industry indices

Somayeh Kokabisaghi ·  
Mohammadesmaeil Ezazi · Reza  
Tehrani · Nourmohammad Yaghoubi

Received: date / Accepted: date

**Abstract** Financial market in oil-dependent countries has been always influenced by any changes in international energy market, In particular, oil price. It is therefore of considerable interest to investigate the impact of oil price on financial markets. The aim of this paper is to model the impact of oil price volatility on stock and industry indices by considering gas and gold price, exchange rate and trading volume as explanatory variables. We also propose Feed-forward networks as an accurate method to model non-linearity. we use data from 2009 to 2018 that is split in two periods during international energy sanction and post-sanction. The results show that Feed-forward networks perform well in predicting variables and oil price volatility has a significant impact on stock and industry market indices. The result is more robust in the post-sanction period and global financial crisis in 2014. Herein, it is important for financial market analysts and policy makers to note which factors and when influence the financial market, especially in an oil-dependent country such as Iran with uncertainty in the international politics. This research analyses the results in two different periods, which is important in the terms of oil price shock and international energy sanction. Also, using neural networks in methodology gives more accurate and reliable results.

---

1.Somayeh kokabisaghi

Faculty of management and economics, University of Sistan and Baluchestan, Zahedan, Iran  
Centrum Wiskunde & Informatica, Amsterdam, Netherlands  
Tel.: +31620988151, E-mail: ms.kokabi@gmail.com, ORCID: 0000-0002-4589-7638

2. Mohammadesmaeil Ezazi

Faculty of management and economics, University of Sistan and Baluchestan, Zahedan, Iran  
E-mail: mohammad.e.ezazi@gmail.com

3. Reza Tehrani

Faculty of Management, University of Tehran, Tehran, Iran  
E-mail: rtehrani@ut.ac.ir

4. Nourmohammad Yaghoubi

Faculty of management and economics, University of Sistan and Baluchestan, Zahedan, Iran  
E-mail: nm.yaghoubi@gmail.com

**Keywords** Feed-forward networks · Industry index · International energy sanction · Oil price volatility

## 1 Introduction

Financial time series has always attracted interests because any dynamic changes caused by economic and political issues influences the analysis of economic and financial variables. For example, in 2008 and 2014, global financial crisis affected interest rate and crude oil price. As a consequence of both crises, there are some sharp downward jumps in the revolution of interest rate and crude oil price. These fluctuations have a strong impact on the economy by disturbing aggregate economic activities. However, the transmission of shocks to economy is hard to explain because of the source of uncertainty that may be driven by supply or demand shocks in the case of oil price. Some researches proved that oil price shocks have different effect in different economies. For example, Kilian and Park (2009) finds that the oil price shocks have different effect on the U.S. economy than on oil-exporting countries. Wang et al (2013) find that oil demand shocks have stronger effect on oil-exporting countries. In this regard, it is expected that higher oil price leads to higher revenue, cash flow and therefore growth in the economy and financial market [3]. There are also concerns about the contagion effects of these shocks on the other financial time series such as stock market, commodities and energy indices [41]and [40] and [2] and [30] and [28], which makes the modelling and estimation of financial variables complicated [21]. hence, understanding the underlying behaviour of oil price is important to keep track of any influences. In this paper we aim to model the effect of oil price volatility on stock market and industry indices. In particular, we investigate how potential uncertainty because of political and economic issues affect financial time series under study. Alongside that we choose Iran as an oil-dependent country where has been under international energy sanctions.

To shed light onto the aim of the paper, we apply a feed-forward neural network to capture and model the effect of unusual behaviours in our datasets. For this purpose, we took an inspiration of several papers that used neural networks to model financial time series with different shocks [15] [1] and [32] and [35].

The reminder of the paper is organized as follow. Section 2 is a summary of literature review, section 3 presents methodology, section 4 is the empirical results and section 5 is the conclusion.

## 2 Literature Review

Since several global financial crises in the past, oil price has fallen sharply and influenced other global and local markets specially oil-dependent countries. Hence, stability in the oil market became an important subject for policy makers and different industries. There are also some evidence that the dynamic of

macroeconomic variables, in particular oil price, affects the industry and stock market behaviour [13] and [31] and [42] and [5]. for example, in 2008 to 2009 oil crisis, stock market followed oil price [10]. differently, Sadorsky (1999) investigated that the dynamic of oil price changes has a negative impact on stock return and industrial production responded to stock return changes positively. Similarly, Wei and Guo (2017) show that oil price shocks have an unstable effect on Chinese stock market. From different results there is still no consensus on the exact impact of the oil price on the stock market. Furthermore, the relationship between oil price and stock market depends on different situations such as the source of global oil shocks, political issues, emerging stock market and whether the country is oil-exporter or oil-importer [4] and [39]. Kilian and Park (2009) find that oil supply shock is not important as oil demand shock in the US stock market as an oil-independent economy. Arouri and Nguyen (2010) studied the relation between oil price and stock market at the aggregate and sector levels and find a significant correlation between these variables. Mensi et al (2013) find a significant volatility transmission between the U.S. stock market (S&P) and commodity indices. They indicate that the volatility in the S&P index can influence oil and gold markets. As it is well understood, the dynamic of oil price and stock market are complicated to get to a conclusion that covers different economies and periods. Therefore, it is crucial to consider different characteristics of the global and national economy and specify the period of study.

In this paper, we focus on the stock and industry markets in Iran as an oil exporting country, which has been under international political conditions for several years. Moreover, we compare results in two periods of oil price shocks and international energy sanction to cover all possible scenarios in the study. The reason is Iran's vulnerability to oil price fluctuations as 60 percent of Iran's government revenue is from oil export earnings [9].

During 2006 to 2009, economic growth has been volatile and decreased to the lowest rate 1.8 percent simultaneously with global financial crisis [43]. Despite the fact that high oil price is beneficial for oil-dependent economies [22] and lower oil price creates instability in oil exporting countries [23], it was expected that the economic growth increases after the global financial crisis with rising oil price; but it did not happen and the economy had a downward rate to -0.2 percent in 2013, which is questionable. A possible reason is international energy imposed on Iran's industries, in particular oil and banking system. It created many restrictions for oil exports, industries and Tehran stock exchange since over 40 percent of industries are involved in the market. Salehi et al, 2015 find that there is strong causality between oil price volatility and stock price in Iran. Therefore, we offer the ideal setting to model the correlation between oil price and stock market and industry by considering gas and gold price, exchange rate and trading volume as explanatory variables.

## 2.1 Overview of Oil price shocks and International Energy Sanction

Sanction as a pressure tool has been used by policy makers to make changes in policies or achieve certain objectives. In general, sanctions direct the Achilles heel of the target; In the case of Iran, restrictions have been focused on energy industry to block any foreign investments in Irans energy industry, exports, and business dealing [34]. It is clear that any services related to the target of sanction have been also involved such as banking system, shipping and insurance, web-hosting services and domain name registration services. In 2007, United Nation Security Council imposed sanctions on Iran and to enforce this country to suspend nuclear activities and also meet the requirements of IAEA (United Nations Security Council. Sanction Resolution no. 1747: UN; 2007. Security Council of United Nations. Resolution no 1929; 2010) It continued till 2010 and banned Iran from any activities related to ballistic missiles and blacklisted all entities and individuals involved with this program such as travelling and financial services.

As US has prohibited all countries from having any deal with Iran, European countries have kept the distance from Iran. These countries dont want to take the risk of losing US financial system because most of international trades are done through the US banks. However, they are not willing to loss investing in Irans energy industry as well. In November 2011, The US, UK and Canada imposed bilateral restrictions on Irans oil and petrochemical industries; UK enforced all British financial institutions to stop doing business with Iranian counterparts. In 2012, Iranian banks were disconnected from the SWIFT (electronic financial transactions). Also, the US tightened sanctions on Irans central bank to block the only channel Iran to get the get the oil export income. Since 2008, the oil market has witnessed two crises. Our study covers the recent oil price shock in mid-2014 When the oil price dropped from 109.62 to 41.5 dollars. Irans oil export dropped from 2433 bp/d to 2371 bp/d and 95 bp/d in 2013. The oil export downward trend was continued to 2014 and Irans energy industry suffered from consequences of international energy sanctions especially from US imposed for more than two decades [16].

Sanctions on oil trades not only disposed Iran of foreign investment flow, it also impressed Irans share in gas sector by disposing access to energy technologies such as LNG technology, which is important for competitiveness in the gas market. As a result, Iran has not been able to exploit gas. Moreover, the national currency, Rial, fell to the lowest record against the US dollar more than 80 percent since 2011. Simultaneously, the government had no choice but to borrow from its Central Bank, which resulted in an increase in the money supply and then inflation [12]. Iranian gross domestic product (GDP) per capita was decreased from 6.95 to -0.87 and 0.147 from 2007 to 2009 respectively [43]. IMF predicted that situation would face Iran to a budget deficit and economys vulnerability would increase [16].

## 2.2 Non-linear model

Oil market and economics is a two-way street and oil price is influenced by many factors and also effects on the economic variables; Hence, modelling has always been an issue for forecasting and decision making. Some studies used econometric models to show the correlation between oil price volatility and stock market; for example, Wei and Guo (2017) applied VAR (vector auto regressive) to show the effect of oil price on stock market in China; (see also, [19] and [38] and [18]). It seems that the statistical methods, that are built on linear assumptions, cannot capture complexity and uncertainty in financial time series. In this regard, researchers were motivated to explain the non-linearity of financial time series by using artificial neural networks ([26] and [37] and [24] and [14] and [6]). The results show that artificial neural networks produce better results than other techniques in simulating unanticipated features of time series. It is because artificial neural network is a data- driven and non-parametric model. In addition, artificial neural networks with simple architecture can be applied to different situations in finance and economics [11] and [8]. besides, it has ability to capture subtle fractional relationship between variables even in time series with different shocks [1] and [32] and [35]. In this paper, we focus on the feed-forward neural networks to explain the behaviours in Tehran stock market and industry.

## 3 Methodology

In this paper, we use Feed-forward network as a precise technique to analyse the results of study in two periods International energy sanction and post-sanction.

### 3.1 The feed-forward architecture

The feed-forward neural network in this study is a layered network with fully connected hidden layers and outputs. In particular , Feed-forward network can arbitrarily and precisely approximate functions with many finite discontinuities as well as their derivatives. Learning the neural networks is important to optimize its architecture by modifying the weights. If learning is done properly the neural network can update connections of neurons and modify weighted function data. The main steps for learning networks are first initializing the network weights and comparing the error values between calculated and observed outputs to find the correction vector. Then, the weights for connections between errors are recalculated by determining the correction vector. figure1 and 2 represent a feed-forward neural network and the activation function.

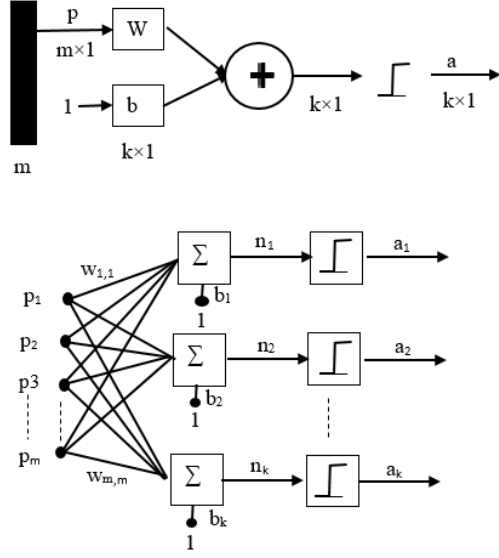

**Fig. 1** This figure shows a Feed-forward networks architecture.  $m$  is the number of inputs shown by  $p$ ,  $k$  is the number of neuron's layer,  $W$  is synaptic weight,  $b$  is bias and  $a$  is hardlimit function

The mathematical structure of the network is shown as follow:

$$u_k = \sum_{j=1}^m W_{kj} p_j \quad (1)$$

where  $u_k$  is the output of the adder (sum of the weighed input signals)

$$\text{hardlimit function} \quad a = \text{hardlim}(W_p + b) \quad (2)$$

$$y_k = a(u_k + b_k) \quad (3)$$

where  $y_k$  is the output signals of the neurons

The feed-forward network in this paper has five inputs including oil price as independent variable and gas and gold price, exchange rate, trading volume as explanatory variables and stock market and industry indices as outputs. In every period of study, hidden layers are calculated as follow:

$$\text{Hidden Layers} = \frac{1}{2}(\text{Inputs} + \text{Outputs}) + \sqrt{\text{Number of training patterns}} \quad (4)$$

In order to specify shocks in time series, we use hardlimit transfer function and the datasets are also divided into two period of sanction and post-sanction.

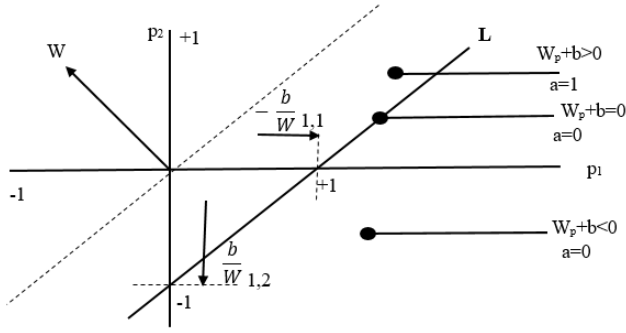

Where  $w_{1,1} = -1$ ,  $w_{1,2} = +1$  and  $b = +1$

**Fig. 2** This figure represents hardlimit transfer function performance that classify net inputs; if net input to the function reaches a threshold, it forces a neuron to output 1, otherwise it outputs zero

Finally, we estimate RMSE and MAPE to assess the accuracy of networks as follow:

$$RMSE = \sqrt{\frac{1}{2} \sum_{t=1}^N (s_t - o_t)^2} \quad (5)$$

$$MAPE = 100 \frac{1}{N} \sum_{t=1}^N \left| \frac{s_t - o_t}{s_t} \right| \quad (6)$$

Where  $s_t$  and  $o_t$  are actual and predicted values at time  $t$  respectively, and  $N$  is the number of observed data.

## 4 Empirical results

### 4.1 Data

For analysis we used information from Iranian Central bank and Organization of the Petroleum Exporting Countries (OPEC). The data comprises daily prices and values for oil, gas and gold price, exchange rate, stock market index, industry index and turn. The empirical research selects 10-year period from December 2008 to December 2018 and it covers international energy sanctions and global financial crises. The reason to choose OPEC oil price is because Iran is a member of OPEC and international crude oils follow the same trends more or less. Table no. 1 summarizes the descriptive statistics associated to the research variables. The information from skewness shows heavy tailed distribution for most of time series, which can be explained by the fact that these economic variables witnessed global financial crisis in 2014 and international

energy sanctions imposed on Iran. The motivation to choose these time series is because of irregularities during the period of study caused by global shocks and sanctions.

**Table 1** Descriptive statistics (Daily data from 2009 to 2018)

	Mean	Median	SD	Skewness	Kurtosis
Oil price (USD)	77.2	75.06	27.29	-0.03	-1.4
Gas price (USD)	3.48	3.42	0.91	0.56	0.7
Gold price (USD)	13.7	1,275	219.6	0.4	-0.2
Exchange rate (USD)	25,573	31,345	11,657	-0.2	-1.57
Stock Index (Unit)	48.779	56,784	28,487	-0.02	-1.5
Industry Index (Unit)	40854.5	48,468	24,791	0.01	-1.6
Trading volume (Million)	626.672193	424.083128	893.369438	10.19	183.3

## 4.2 Learning Feed-forward Network

### 4.2.1 The period of International energy sanction

The first dataset includes 1845 data from 2009 to 2018 when international energy sanction was tightening on Iran. The datasets are divided into two sections, the training set and the test set. 25 percent of dataset is used and then normalized as test set.

In the first pattern, there are five inputs including oil, gas and gold price, exchange rate, trading volume and stock market and industry indices as outputs separately and 40 hidden layers are calculated.

The results of learning feed-forward network presented in Figures 3 and 4 which depict that the data is close to fitted line (perfect fit) and not much deviation between the predictive values and the actual values. Figures also indicate the overall accuracy of model in predicting stock and industry indices. The results of learning network provide 90 percent accuracy for both indices. Although oil price and indices have been volatile with different upward trends. The network is able to handle this volatility and noise without over fitting the data.



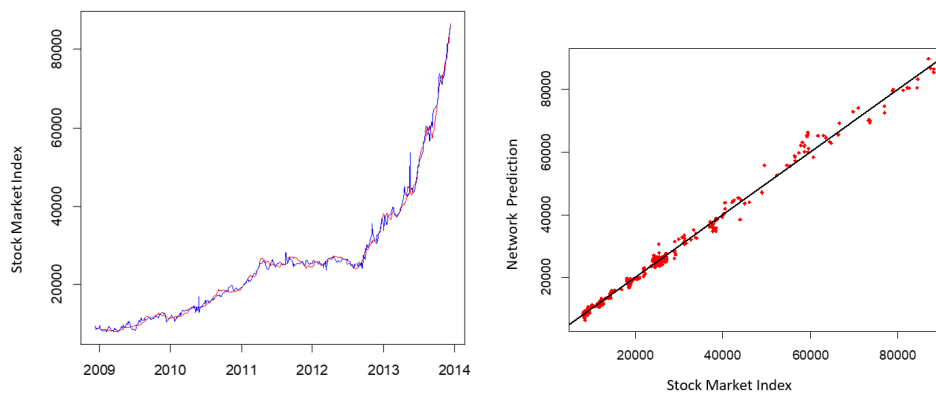

**Fig. 3** The left figure represents Tehran stock market index prediction and actual data; The red line is actual values and blue line is feedforward network prediction; The right figure shows Tehran stock market index and fitted line (in the period of international energy sanction)

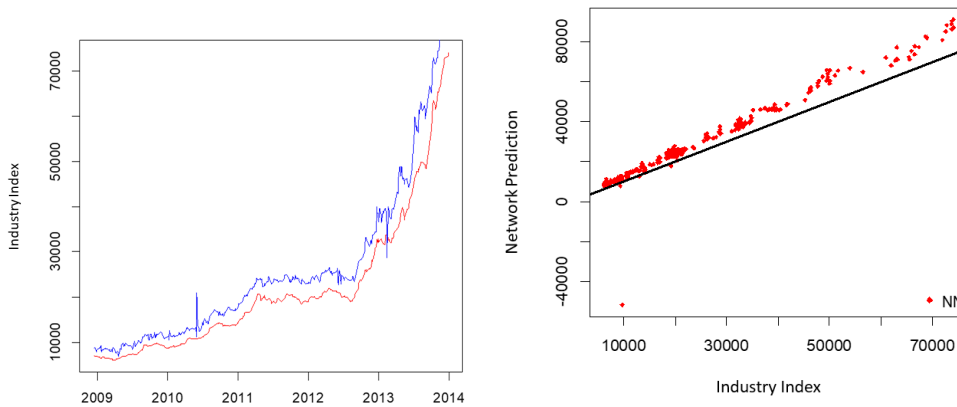
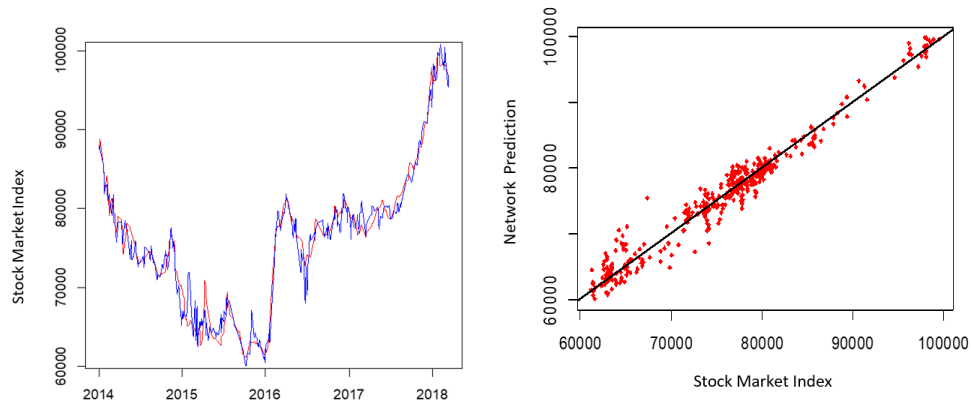

**Fig. 4** The left figure shows Industry index prediction and actual data; The red line is actual values and blue line is feedforward network prediction; The right figure represent Industry index and fitted line (in the period of international energy sanction)

#### 4.2.2 Post sanction and global financial crisis

The second dataset starts from 2014 to 2018 when oil price was influenced by global financial crisis. In this period, international energy sanction was eased on Iran. Similar to the first pattern, 25 percent of total 1540 data were selected as test set. The network includes 5 inputs, one output every time and 37 hidden layers. The learning was run 1234 times till the network became

converged. The results with 90 percent accuracy for both stock and industry indices is presented in figure 5 and 6 respectively. Figures show that the feed-forward network has the ability to produce a good prediction by considering other economic variables as the data is so close to the perfect fit.



**Fig. 5** The left figure shows stock market index prediction and actual data. The red line is actual values and blue line is feedforward network prediction; The right figure shows stock market index and fitted line (perfect fit) (In post-sanction and global financial crisis)

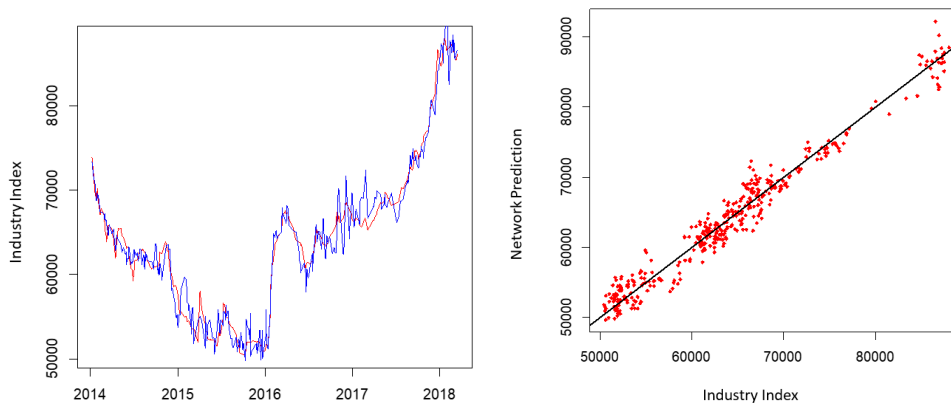

**Fig. 6** The left figure shows Industry index prediction and actual data; The red line is actual values and blue line is feedforward network prediction; The right figure represents Industry index and fitted line (perfect fit) In post-sanction and global financial crisis

The average percentage error (MPE), estimated root mean square error (RMSE) and mean absolute percentage error (MAPE) from learning feed-forward network for both stock and industry indices are listed in Table 2.

Take the stock market index in the first period for example, the values of criteria MAE, RMSE, MAPE are smaller and shows that the model has a better performance than industry index.

**Table 2** Corresponding values of the evaluation criteria

Dependent variables	International energy sanction		Post-sanction	
	Stock index	Industry index	Stock index	Industry index
MPE	0.107	0.116	0.107	0.09
RMSE	1106	1629	1750	1734
MAPE	0.07	0.16	0.23	0.33

## 5 Conclusion

In this paper, we analysed the impact of oil price volatility on stock and industry indices. In order to have a more realistic and accurate model, first we considered gas and gold price, exchange rate and trading volume as explanatory variables then we applied a Feed-forward network to capture all features of time series under study. Finally, we compared the results in both periods of sanction and post-sanction. The first set of results indicate the positive effect of oil price on stock and industry indices, which is supported by empirical studies [17] and [7] and [29]. In addition, the feed-forward networks predict stock and industry indices with 90 percent accuracy in both sanction and post-sanction periods. From the evaluation criteria, we found that the oil price shock has a significant impact on stock and industry indices in the period of post-sanction. In the other words, industry and stock market indices are influenced more by oil price shock in 2014 than international energy sanction. We can draw a conclusion that Iran as an oil-dependent country is more vulnerable to endogenous changes in oil market such as crises. Our study also indicates that stock and industry indices had a smoother increasing trend in the period of sanction, while oil price was increasing from 2009 to 2014. The possible scenario for these slow changes is because of the presence of international energy sanctions. On one side, Iran's oil export was restricted; on the other side, Iran could compensate the lack of oil export by changing the target markets to export oil and increasing gas export instead of oil. In this paper, we have addressed the important question how different disruptions in the oil market (due to sanctions or price shocks) influence stock market and industry in an oil dependent economy. The results point out complexity in analysing economic and financial variables, which requires a special attention to all important factors and aspects of the economy. Future research might concentrate on the source of oil price shocks which best captures the effect of supply and demand on industry. Finally, the effect of oil price shocks and international energy sanction on the oil-dependent companies in stock market is matter. In

addition, another interesting direction for future work would be to apply the proposed method on indices in banking system.

**Acknowledgements** The authors are very grateful to dr. Eric Pauwels for his valuable comments on this paper.

### Conflict of interest

The authors declare that they have no conflict of interest.

### References

1. Atsalakis, G. S. and Valavanis, K. P., Surveying stock market forecasting techniques soft computing methods, *Expert Systems with Applications*, Vol. 36, 5932-5941 (2009).
2. Angelidis, T., Degiannakis, S. and Filis, G. , US stock market regimes and oil price shocks, *Global Finance Journal*, Vol. 28, 132-146 (2015).
3. Arouri, H., El, M. and Nguyen, K. , Oil prices, stock markets and portfolio investment: Evidence from sector analysis in Europe over the last decade, *Energy Policy*, Vol. 38, 4528-4539 (2010).
4. Basher, S. A. and Sadorsky, P. , Oil price risk and emerging stock markets, *Global Finance Journal*, Vol. 2, 224-251 (2006).
5. Bastianin, A., Conti, F. and Manera, M., The impacts of oil price shocks on stock market volatility: Evidence from the G7 countries, *Energy Policy*, Vol. 98, 160-160 (2016).
6. Bissoondeeal, R.K., Karoglou, M. and Gazely, A.M. , Forecasting the UK/US exchange rate with divisia monetary models and neural networks, *Scottish Journal of Political Economy*, Vol. 58, 127-152 (2011).
7. Ewing, B., and Malik, F., Volatility spillovers between oil prices and the stock market under structural breaks. *Global Finance Journal*, Vol. 29, 12-12(2016).
8. Fahima C. and Ayachi, F. , Non-linear causality between exchange rates, inflation, interest rate differential and terms of trade in Tunisia, Vol. 9, 274-289 (2018).
9. Farzanegan, M. and Markwardt, G. , The effects of oil price shocks on the Iranian economy, *Energy Economics*, Vol. 31, 134-151 (2009).
10. Filis, G., Degiannakis, S. and Floros, C. , Dynamic correlation between stock market and oil prices: the case of oil-importing and oil-exporting countries, *International Review of Financial Analysis*, Vol. 20, 152-152 (2011).
11. Galeshchuk, S. , Neural networks performance in exchange rate prediction, *Neurocomputing*, Vol.172, 446-452 (2016).
12. Ghorbani Dastgerdi, H., Yusof,Z. and Shahbaz, M., Nexus between economic sanctions and inflation: a case study in Iran, *Applied Economics*, 50(49) 5316-5334 (2018).
13. Gntner, J.H.F. , How do international stock markets respond to oil demand and supply shocks?, *Macroeconomic Dynamics*, Vol.18, 1657-1682 (2014).
14. Gurusen, G., Kayakulu, G. and Daim, T. , Using artificial neural network model in stock market index prediction, *Expert System Application*, Vol. 38, 1038910397 (2011).
15. Ince, H., Cebeci, A.F. and Imamoglu, S.Z, *Comput Econ*, Vol. 53, 53- 817 (2019).
16. International Monetary Fund, , Islamic Republic of Iran and the IMF, Retrieved from <https://www.imf.org/en/Countries/irn> (2018).
17. Fang, S. and Egan, P. , Measuring contagion effects between crude oil and Chinese stock market sectors, *The Quarterly Review of Economics and Finance*, Vol. 68(C), 31-38 (2018).
18. Huang, J.I. , The relationship between oil price and bond/stock market: a sectoral analysis, Temple University, p. 10144417 (2016).
19. Kang, W. and Ratti, R.A. , Oil Shocks, Policy Uncertainty and Stock Returns in China, *Economics of Transition*, Vol. 23, 657-676 (2015).

20. Keshavarz Hadad, G.R. and Manavi, H. , Interaction between stock market and foreign exchange market in Iran with an emphasis on the impact of oil shocks, *Economic Research in Iran*, Vol. 37, 147-169 (2008).
21. Kokabisaghi, S., Pauwels, E.J., Meulder, K.V. and Dorsman, A. , Are These Shocks for Real? Sensitivity Analysis of the Significance of the Wavelet Response to Some CKLS Processes, *International Journal of Financial Studies*, Vol. 6, pages 1-12 (2018).
22. Korhonen, I. and Ledyeva, S. , Trade linkages and macroeconomic effects of the price of oil, *ENERGY ECONOMICS*, Vol. 32, 848-856 (2010).
23. Kitous, A., Saveyn, B., Keramidas, K., Vandyck, T., Rey Los Santos, L. and Wojtowicz, K. , Impact of low oil prices on oil exporting countries, *EUR 27909 EN* (2016).
24. Kristjanpoller, W. and Minutolo, M.C. , Gold price volatility: A forecasting approach using the Artificial Neural Network-GARCH model, *Expert Systems with Applications*, Vol. 42, 7245-7251(2015).
25. Kilian, L. and Park,C. , The impact of oil price shocks on the U.S. stock market, *International Economic Review*, Vol. 50, 1267-1287 (2009).
26. Lu, C. and Wu, J. , An efficient CMAC neural network for stock index forecasting. *Expert Systems with Applications*, Vol.38, 15194-15201 (2011).
27. Mensi, W., Makram, B., Adel, B. and Shunsuke, M., Correlations and volatility spillovers across commodity and stock markets: Linking energies, food, and gold, *Economic Modelling*, Vol. 32(C), 15-22 (2013).
28. Moya-Martnez, P., Ferrer-Lapea, Ro. And Escribano-Sotos, F., Oil price risk in the Spanish stock market: An industry perspective, *Economic Modelling*, Vol. 37(C), 280-290 (2014).
29. Mezghani, T. and Boujelbne, M. , The contagion effect between the oil market, and the islamic and conventional stock markets of the gcc country, *International Journal of Islamic and Middle Eastern Finance and Management*, Vol.11, 157-181 (2018).
30. Niknam Esfahani, N. , The impact of macroeconomic variables on the stock market of the oil-exporting countries: The case of Iran, *Alliant International University*, p. 10243507(2016).
31. Nusair, S.A. , The effects of oil price shocks on the economies of the gulf cooperation council countries: nonlinear analysis, *Energy Policy*, Vol. 91, 256267 (2016).
32. nder, E., Bayr, F. and Hepsen, A. , Forecasting macroeconomic variables using artificial neural network and traditional smoothing techniques, *Journal of Applied Finance and Banking*, Vol. 3, 73-104 (2013).
33. Sadorsky, P. , Oil price shocks and stock market activity, *Energy Economics*, Vol. 21, 449469 (1999).
34. Sabatini,R. , Economic Sanctions: Pressuring Irans Nuclear Program, *NTI-Monterey Institute of International Studies*. Washington, 24 (2010).
35. Svitlana, G. , Neural networks performance in exchange rate prediction, *Neurocomputing*, Vol. 172, 446-452 (2016).
36. Salehi, M., Dashtbayaz, M.L., Bahrami, M. and Mosallapour, M. , Relationship between oil price fluctuations and stock price index in Iran, *Investment Management and Financial Innovations*, Vol.12 No, 4, 23-33 (2015).
37. Ticknor, J.L. , A Bayesian regularized artificial neural network for stock market forecasting, *Expert Systems with Applications*, Vol. 40, 5501-5506 (2013).
38. Pandey, V. and Vipul. , Volatility spillover from crude oil and gold to BRICS equity markets, *Journal of Economic Studies*, Vol. 45, 426-440 (2018).
39. Wang, Y., Wu, C. and Yang L. , Oil price shocks and stock market activities: evidence from oil-importing and oil-exporting countries, *Journal of Comparative Economics*, Vol. 41, 1220-1239 (2013).
40. Wei, Y. and Guo, X. , Oil price shocks and China's stock market, *Energy*, Vol. 140 (P1), 185-197 (2017).
41. Wen, X., Wei, Y. and Huang, D. , Measuring contagion between energy market and stock market during financial crisis: A copula approach, *Energy Economics*, Vol. 34, 14351446 (2012).
42. Zhang, C. and Tu, X., The effect of global oil price shocks on China's metal markets, *Energy Policy*, Vol. 90, 131139 (2016).
43. World Bank,Country report; <https://data.worldbank.org/country/iran-islamic-rep?view=chart> (2018)