



**Tiago Ventura da
Silva Ribeiro
Machado**

**Redesign e teste de viga seletora em sistema de
transporte de volumes**

SCO sort beam redesign



**Tiago Ventura da
Silva Ribeiro
Machado**

Redesign e teste de viga seletora em sistema de transporte de volumes

SCO sort beam redesign

Relatório de Estágio apresentado à Universidade de Aveiro para cumprimento dos requisitos necessários à obtenção do grau de Mestre em Engenharia Mecânica, realizada sob orientação científica do Professor Doutor António Manuel de Amaral Monteiro Ramos, Professor Auxiliar do Departamento de Engenharia Mecânica da Universidade de Aveiro e supervisão de Koen Grob-ben, Arquiteto de Sistemas do Departamento de Arquitetura do Produto da Vanderlande Industries e de Fred van Toor, Engenheiro Sênior de Desenvolvimento Mecânico do Departamento de Desenvolvimento Mecânico da Vanderlande Industries.

*Great men have almost always
shown themselves as ready
to obey as they afterwards
proved able to command.*
- Lord Mahon

O júri / The jury

Presidente / President

Prof. Doutor João Alexandre Dias de Oliveira

Professor Auxiliar da Universidade de Aveiro

Prof. Doutor José António de Oliveira Simões

Professor Coordenador com Agregação da Esad - Escola Superior de Artes e Design de Matosinhos (Arguente)

Prof. Doutor António Manuel de Amaral Monteiro Ramos

Professor Auxiliar da Universidade de Aveiro (Orientador)

agradecimentos / acknowledgements

Gostaria de agradecer à minha família por todo o apoio prestado ao longo destes 5 anos mas, claro, com um foco especial ao meu pai e à minha mãe por me proporcionarem todas estas aventuras e me apoiarem nas minhas decisões.

Gostaria também de agradecer à Mariana e aos meus amigos (meus fiéis cãespanheiros) pelos melhores 5 anos de sempre. Que venham muitos mais! Um enorme agradecimento à Vanderlande pela incrível oportunidade que me deu. Agradeço a toda a equipa de Desenvolvimento Mecânico, colaboradores externos e estagiários pela ajuda e bons almoços nestes últimos meses. Agradeço especialmente ao Koen e ao Fred da Vanderlande e ao Prof. Doutor António Ramos por me guiarem durante o estágio. Por último mas não menos importante, agradeço à Universidade de Aveiro e ao Departamento de Engenharia Mecânica por tornarem este estágio possível.

I would like to thank to my family for all the support given throughout the last 5 years but, of course, I want to thank especially to my dad and my mum for providing me all these adventures and support me with my decisions.

I also want to thank to Mariana and to my friends (my fellow mates) for the best 5 years ever. I am looking forward to many more!

A huge thanks to Vanderlande for the incredible provided opportunity. I want to thank to all the Mechanical Development team, external collaborators and interns for the help and funny lunches for the last months. I want to give a special thanks to Koen and Fred from Vanderlande and Professor António Ramos for guiding me during the internship.

Last but not least, I am grateful to the University of Aveiro and to the Mechanical Engineering Department for making this internship possible.

keywords

Compaxorter, Fin Ray, Motion Analysis, Simulation, Sort Beam

abstract

The parcel and postal market is requesting higher and higher sorting capacities of Vanderlande sorters. One of the companies line of sorters is the Compaxorter which uses a beam to sort a parcel instead of a shoe. Compared to the shoe, a sort beam has some disadvantages regarding machine and human safety. Redesigning the sort beam in order to be flexible would reduce or solve the disadvantages. During the development procedure, two prototypes were created and tested along with a multi-body mathematical model to simulate the motion of one component of the prototype, the bracket. The first prototype was created after several concepts were generated. Once the concept that best fitted the key requirements was chosen, it was improved and turned into the first prototype. After testing prototype alpha, valuable information was created regarding its design and the bracket movement. Afterwards, based on the generated information, either the sort beam and bracket went through a new redesign phase. Therefore, the second prototype was produced and tested. The results were positive for the bending event but the bracket mechanism was still not ideal. Therefore, the multi-body mathematical model was created to predict manually its motion and, then, helping with its design.

palavras-chave

Compaxorter, Fin Ray, Análise de Movimento, Simulação, Viga Seletora

resumo

O mercado de encomendas e correio está a exigir cada vez mais altas capacidades das máquinas sorteadoras da Vanderlande. Uma das máquinas da empresa é o Compaxorter que usa uma viga para sortear uma encomenda em vez de um sapato. Comparando ao sapato, a viga seletora tem certas desvantagens no que toca à segurança da máquina e dos operadores. Redesenhar a viga sorteadora de maneira a torná-la flexível pode reduzir ou até eliminar as desvantagens. Durante o processo de desenvolvimento, dois protótipos foram produzidos e testados juntamente com um modelo matemático multi-corpo que simula o movimento de um componente do protótipo, o bracket. O primeiro protótipo foi produzido após várias ideias serem geradas. O conceito que mais se adequava aos requisitos foi escolhido, melhorado e depois transformado então no primeiro protótipo. Após testar o protótipo alfa, foi gerada informação importante relativamente ao seu design e ao movimento do bracket. Com base nessa informação, a viga e o bracket foram novamente redesenhados. Desta maneira, o segundo protótipo foi produzido e testado. Os resultados foram positivos no que diz respeito à flexibilidade da viga mas o mecanismo do bracket ainda não era ideal. Portanto, o modelo matemático multi-corpo foi criado para prever manualmente o seu movimento, culminando com o seu redesign.

Contents

Company Presentation	1
I Introduction and Background	3
1 Introduction and Background	5
II Current Design	7
2 Compaxorter	9
2.1 How It Works	11
3 Sort Beam	13
3.1 Problem Description	13
3.1.1 Risks	14
3.1.2 Current Solution	14
III Methodology and Development	17
4 Methodology	19
4.1 Plan of Action	19
4.2 Requirements	21
4.2.1 Primary Requirements	21
4.2.2 Secondary Requirements	22
5 Development	25
5.1 Morphological Analysis	25
5.2 Concepts	27
5.2.1 Fragmented Concepts	27
5.2.2 Flexible Concepts	28
5.3 Decision Analysis	30
5.3.1 Concept Analysis Matrix	31
5.3.2 Detailed Analysis	33

5.4	Concept Development	33
IV	Functional Prototypes	37
6		39
6.1	Prototype Alpha	39
6.1.1	Bracket	39
6.1.2	Physical Test	41
6.1.3	Prototype Beta Development	44
6.2	Prototype Beta	53
6.2.1	Physical Test	53
6.2.2	Posisorter Test	55
V	Prototype Analysis	61
7	Bracket Behaviour	63
7.1	MATLAB Model	63
7.1.1	Inputs	64
7.1.2	Bracket Design	65
VI	Future Work	69
8	Sort Beam Design	71
8.1	Front Part	71
8.1.1	Sort Beam Design	71
8.1.2	Bracket Design	72
8.2	Back Part	72
8.2.1	Flanges Design	72
8.2.2	Bracket Mechanism	73
8.3	General Suggestions	74
9	Material and Process Selection	77
9.1	Production Process Selection	77
9.2	Material Selection	77
9.3	General Suggestions	79
VII	Discussion	81
VIII	Conclusion	87
Annex		89

List of Tables

- 5.1 Morphological analysis. 26
- 5.2 Concept analysis matrix. 32

- 6.1 Prototype alpha measurements. 44
- 6.2 Prototype beta measurements. 59

- 7.1 Bracket tip displacement measurement. 64

- 9.1 Range of mechanical properties for various dry engineering plastics at room temperature. [8] [12] 78
- 9.2 FEM results for different materials. 79
- 9.3 Primary requirements status. 84
- 9.4 Secondary requirements status. 85
- A1 Concept analysis matrix overview. 92
- A2 Detailed decision analysis. 93
- A3 Thermoplastics processing methods. [11] [12] 101

List of Figures

2.1	Illustration of a working SCO.	9
2.2	Posisorter overview.	10
2.3	Compaxorter overview.	10
2.4	Compaxorter CAD overview.	11
2.5	Drive section main components.	12
3.1	Current sort beam with divert shoe.	13
3.2	Drive section of SCO.	14
3.3	Safety tunnel.	15
4.1	Plan of action diagram.	20
4.2	Sort beam angles in the drive section.	22
4.3	Top view of the SCO with switch frame angles.	23
4.4	Simplified switch frame angles.	24
5.1	Representation of the hinge mechanism concept.	27
5.2	Representation of the coupling concept.	28
5.3	Representation of the spring concept.	29
5.4	Representation of the half spring concept.	29
5.5	Representation of the butterfly concept.	30
5.6	Representation of Fin Ray [®] concept.	31
5.7	Chosen concepts.	33
5.8	FEM simulation displacement results for vertical and tilted flanges.	34
5.9	FEM simulation displacement results for the last iterated model.	35
5.10	CAD overview of prototype alpha.	35
6.1	Bracket hole.	39
6.2	Bracket components.	40
6.3	Bracket assembly.	40
6.4	Illustration of the bracket mechanism.	41
6.5	Prototype alpha after physical changes.	41
6.6	Prototype alpha test results.	42
6.7	Prototype measurements.	43
6.8	CAD overview of the new study model.	45
6.9	CAD overview of the new study model interior.	45
6.10	FEM simulation stress results for the new study model.	46
6.11	Flange orientation modification.	47
6.12	CAD overview of the models with different flanges orientation.	48
6.13	FEM simulation displacement results for different flanges orientation.	48

6.14	High stresses between side cover and bottom surface.	49
6.15	Stresses between side cover and bottom surface after redesign.	50
6.16	Bracket testing set.	50
6.17	Tested brackets.	51
6.18	Bracket iteration.	52
6.19	Bracket with plastic block.	52
6.20	Prototype beta.	53
6.21	Prototype beta on testing set.	54
6.22	Redesigned plastic block.	54
6.23	Prototype beta interference with carrier.	55
6.24	Side and top views of prototype beta in Posisorter.	55
6.25	Prototype beta manual test.	56
6.26	Upside down prototype beta in Posisorter.	57
6.27	Prototype beta automatic test.	58
7.1	Carrier movement representation.	63
7.2	Bracket tip displacement.	64
7.3	CAD overview of adapted bracket support.	65
7.4	CAD overview of the MATLAB iterated brackets.	66
7.5	Prediction of the bracket movement.	67
8.1	Suggested revision to prototype beta.	71
8.2	Suggested concept for complete sort beam.	72
8.3	Back flanges orientation.	73
8.4	Suggested sort beam design.	73
8.5	CAD overview of suggested divert shoe.	74
8.6	Explanation of the suggested bending mechanism.	75
9.1	Injection moulding plastics properties. [26]	78
A1	User interaction with safety tunnel.	91
A2	Position, velocity and acceleration graphs on the switch frame.	91
A3	Distance between the carrier flange and current sort beam.	92
A4	FEM simulation displacement results for two different designs.	94
A5	Prototype alpha mounted in Posisorter.	94
A6	Prototype alpha results analysis.	95
A7	FEM stress results of the new study model.	95
A8	Bending moments of the iterated bracket.	96
A9	Side surface and bottom modification on prototype beta.	97
A10	Bracket position stages.	97
A11	Reaction of prototype beta to the bracket pressure.	98
A12	Limit for the bracket.	98
A13	MATLAB iterated brackets differences.	98
A14	Example of suggested sort beam.	99
A15	Suggested sort beam length.	99
A16	Example of the sort beam cover.	100

Vanderlande Industries

History

Vanderlande Industries was established in 1949, in Veghel, the Netherlands, and it was dedicated to the refurbishment and production of machines for the textile industry. Afterwards, it changed its business to the manufacture of hoisting apparatus, cranes and conveyor belts for bulky materials and barrels of oil.

After 1963, the organisation started a partnership with Rapistan Incorporated, developing and building customised transport systems establishing the beginning of a successful global organisation.

Later, in 1988, Vanderlande majority shares was acquired by NPM Capital, enabling the company to achieve long-term goals and international expansion.

In a very recent past, in 2017, Toyota Industries Corporation (TICO) acquired Vanderlande. The two companies strategically matched and the financial strength of Toyota is helping Vanderlande with its sustainable profitable growth.

Currently, Vanderlande is a global developer and manufacturer of logistic process automation at airports and in the parcel market. It designs and produces machines that convey, store, sort baggage in airports and conveyors that are able to sort any type of parcels with a lead delivery time. The company also supplies process automation solutions for warehouses - innovative systems, intelligent software and life-cycle services.

The company has over 6500 people worldwide and a consistent increasing turnover of 1.5 billion euros. Vanderlande customers are Amazon, DHL, Fedex, Istanbul Airport, LAX, London Heathrow, Nike, UPS, and many more.

Products

Vanderlande has a large variety of products for airports, parcel market and warehousing. The solutions are developed entirely in house and partially manufactured.

For airports, the company has solutions like FLEET and PAX CHECKPOINT. For the parcel market, the most famous conveyors are the Posisorter, Crossortes and Compaxorter. Last but not least, the company also offers solutions for warehousing, like ADAPTO and QUICKSTORE.

Part I

Introduction and Background

Chapter 1

Introduction and Background

Introduction and Motivation

Continuous population growth and technological advancements stimulate social, cultural, economical and political changes that are translated into constant market variations. This trend of repetitive transformations compel companies to search for new techniques and innovative technologies that allow them to have not an economical growth but a sustainable profitable growth. Due to these changes, people are changing their habits: from having business meetings every week in another country instead of doing a video call to order food and consumer goods with a click instead of going to the respective shop. It is in this scenario that Vanderlande plays a huge role. In the parcel market, it makes sure that the order placed from your laptop reaches your house undamaged in a lead time.

To keep up with the increasing customers requirements for customised products with better quality, lower price and shorter deadlines, innovation is one of the pillars of every entity that wants to overcome these demands. Hence, the current project emerged. The Compaxorter is a sorter manufactured by Vanderlande that performs well and meets its expectations. However, there are aspects that can be improved, like the sort beam. The importance of a new redesigned sort beam in the current competitive environment is demonstrated by its advantages: increased safety of the system, decreased total cost of the system and decrease vibrations and sound. These improvements to the current sort beam and Compaxorter are part of the motivation for this project, once they make this topic extremely appealing, modern and innovative.

My Exchange Programme takes the other part with regard to my decision of finishing my degree abroad. One year before I started this graduation internship, also in the Netherlands, I had the opportunity to understand the dutch working culture. Only two weeks were needed to make up my mind of experiencing the working environment throughout an international internship instead of a thesis abroad. The offer from Vanderlande was the most interesting and practical. Thus, I very cheerfully entered the company for the project.

Background

The parcel and postal market is requesting higher sorting capacities of the line sorters. One of the company line sorters is the Compaxorter which uses a beam to sort a parcel instead of a shoe (like the Posisorter). Positive shoe sorting uses a wheel beneath the shoe that is "activated" by a divert switch. The wheel is pushed in a track, the shoe will follow and sort the parcel. Compared to the shoe, a sort beam has some disadvantages regarding machine and human safety.

Changing the sort beam design might reduce or solve the disadvantages. Additionally, the shoe shape of the Posisorter might be edited as well. This affects the way a shoe pushes a parcel off the sorter. The shape of the shoe and its functionality is fundamental in the sorting process. In this project, a new sort beam design is investigated, either for fragmented and flexible beams.

Firstly, the Compaxorter and the sort beam were analysed in depth to understand their functionality and risks.

After understanding the sorter and the problem that the current sort beam has, theoretical solutions were generated with the help of a morphological analysis. One of these ideas was selected throughout a decision analysis in order to be developed and turned into a functional prototype. Along side the sort beam prototype, another component was developed, the bracket. This component is responsible for bending the prototype.

Moreover, when the first prototype was tested and its results analysed, improvements were made to the sort beam and bracket designs. Hence, these improvements resulted on a second prototype. The new improved prototype exhibited positively the results from the design changes on both components. However, the bracket was still not ideal. It was capable of bending the sort beam, but it was applying pressure before it should, i.e. before the sort beam reaches the drive section (end of the sorter). Therefore, a mathematical model was developed in order to predict manually the behaviour of this component.

Towards the end of the project, there was no time to produce another prototype. In such a way, the model was fully developed but it was not tested.

Part II

Current Design

Chapter 2

Compaxorter

The Compaxorter (SCO) is a horizontal sorting system that sorts small product handling units (PHU) for the parcel and postal market (see figure 2.1).

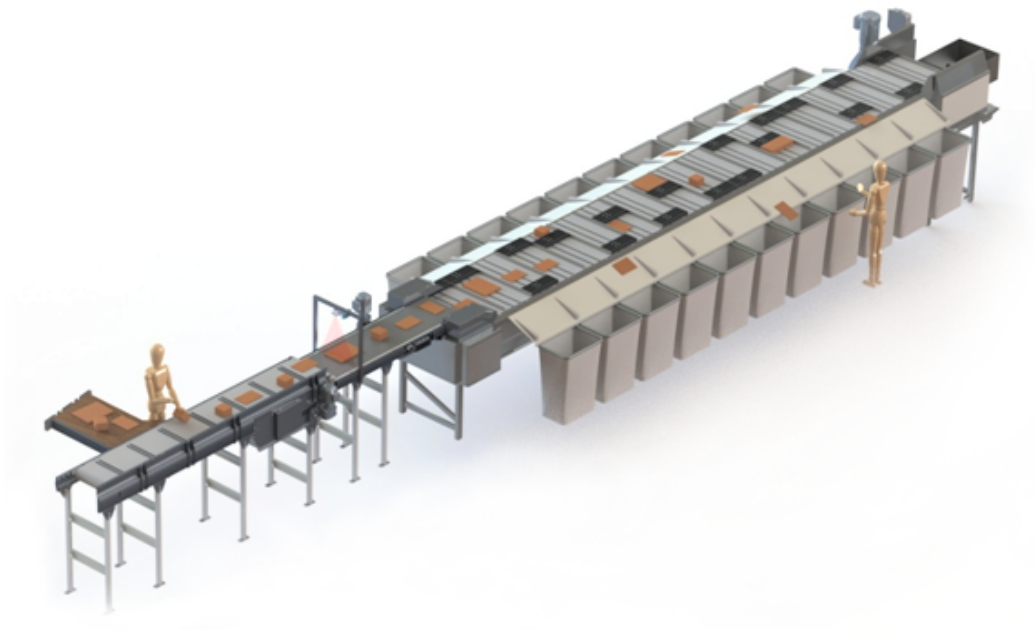

Figure 2.1: Illustration of a working SCO.

The SCO is based on the Posisorter (SPO). The SPO is a proven and very reliable machine which has a large installed base. Both sorters belong to the same line-sorter family and the SCO shares most of the components with the SPO. Whilst the SPO uses a shoe in every carrier to sort parcels (see figure 2.2), the SCO has a shoe every 3 or 4 carriers, depending on the requested model. On top of the shoe, a sort beam with the length of approximately 3 or 4 shoes in a row is attached. The working principle is the same, but the parcel will be sorted by the sort beam rather than by 3 or 4 shoes (see figure 2.3).



Figure 2.2: Posisorter overview.



Figure 2.3: Compaxorter overview.

2.1 How It Works

Extruded aluminium beams called carriers are connected to chains forming a belt like surface in which PHUs can be conveyed. Wheels connected to the chains guide them over a steel frame. That chain is propelled by a motor in the drive section and an End Take Up (ETU) section is used as a return of the chain belt (see figure 2.4).

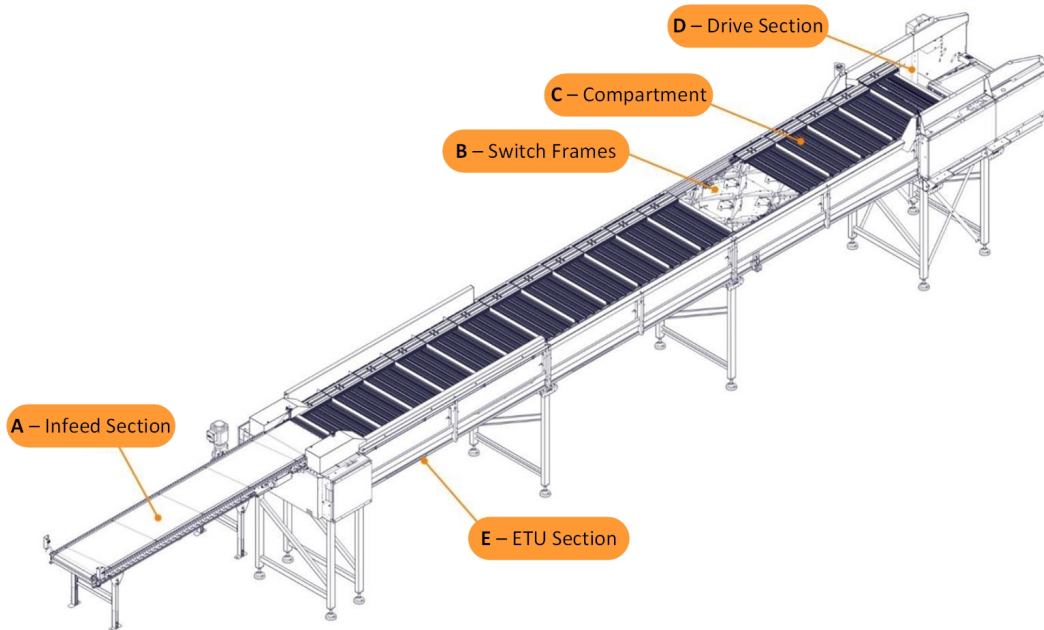

Figure 2.4: Compaxorter CAD overview.

The SCO uses compartments (also called windows) on the chain belt by having a "slide profile flange" every third or fourth carrier. Every compartment can house and sort a single PHU. A sort beam is mounted on top of a plastic divert shoe and this set is then assembled on a carrier within a compartment (see figure 2.5).

Beneath the carriers is a switch frame with guiding rails that guide a wheel which is attached to the bottom part of the divert shoe (see figure 2.4). The sort beam position is on the left or right side of the compartment. When sorting, the sort beam is guided to the other side of the carrier pushing the PHU into a designed and prepared exit.

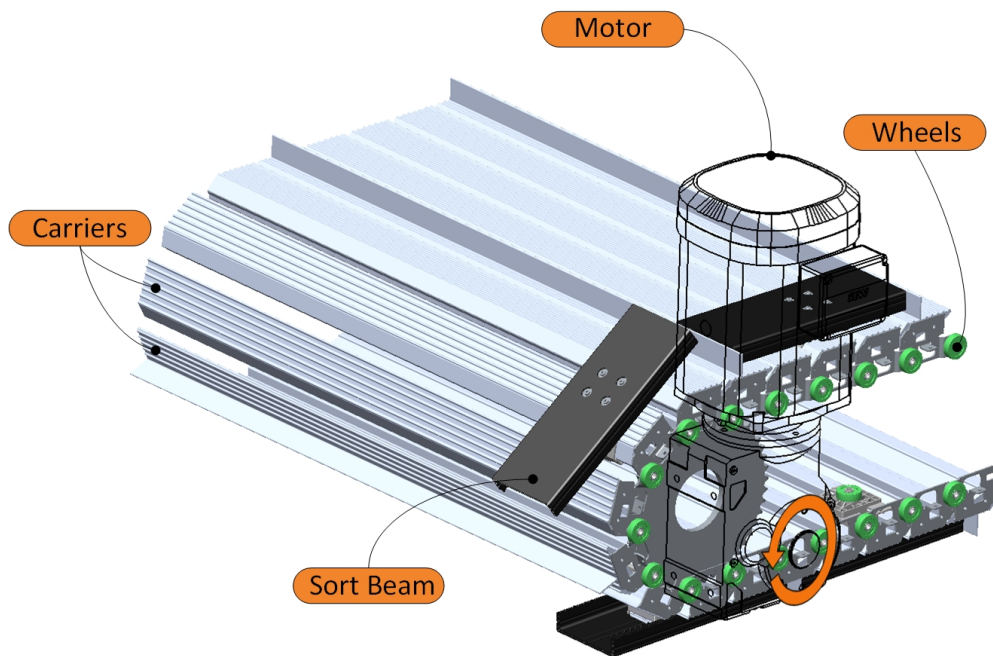

Figure 2.5: Drive section main components.

Chapter 3

Sort Beam

The current sort beam (see figure 3.1) has an inversed *C* shape because it has to be attached to the top of a divert shoe and it must have brushes on the edges. Its thickness, 6 mm on top and 8 mm on both sides, is defined from the production process of the sort beam - metal (aluminium) extrusion. The sort beam's exterior dimensions are $495 \times 183.3 \times 51.1$ mm and it weights approximately 1.6 kg.

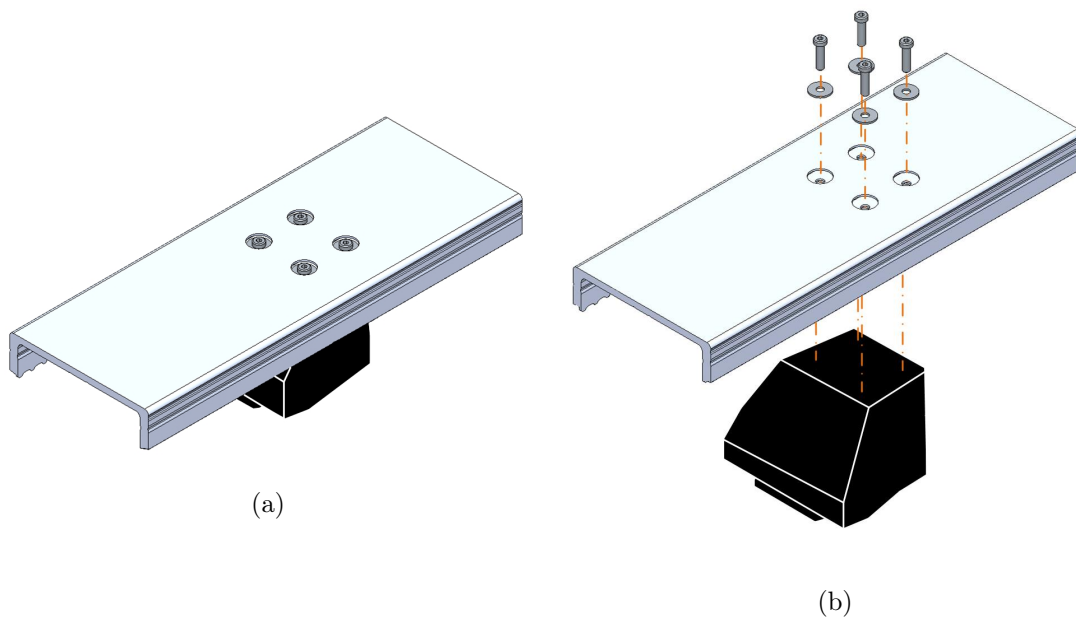

Figure 3.1: Current sort beam with divert shoe.

3.1 Problem Description

The SCO itself and the interface with the environment contains different hazards. Different safety measures have already been taken in the design of the SCO, i.e. the safety tunnel (see chapter 3.1.2). However, some risks are still remaining.

The radius travelled by both ends of the sort beam is larger than the one done by the shoe with the beam attached to it (530 mm against 330 mm, considering the centre

of the gear as the referential in the drive section – see figure 3.2a).

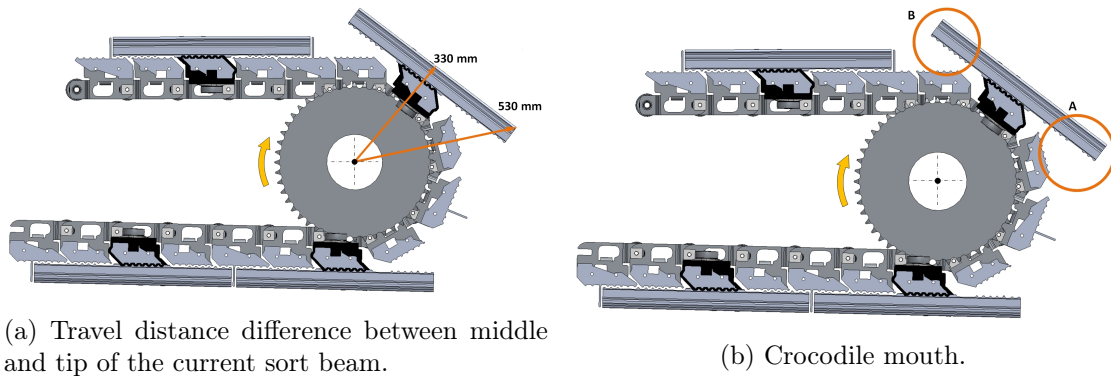

Figure 3.2: Drive section of SCO.

Due to this travel distance difference, an opening between the tip of the sort beam and the corresponding carriers is present – what is called a "crocodile mouth" (see figure 3.2b). It is not safe for the user/machine operator to come close to it due to the fast moving sharp edges (1.7 m/s).

3.1.1 Risks

There is a probability of damaging the user if he/she tries to reach the drive section while the sorter is operational.

When the carrier below the tip of the sort beam reaches the end of the conveyor and, through a gear, goes under the conveyor itself, the sort beam will not follow the path of that carrier since it is only fixed in one of the carriers behind (see A and B in figure 3.2b). The front of the sort beam has a radius of curvature of 530 mm to the centre of the gear in the drive section whilst the section of the sort beam which is fixed to the shoe has a radius of 330 mm (see figure 3.2a).

As a result of this significant travel distance difference, the "crocodile mouth" is present. While the SCO is operational, anything between the tip of the sort beam and the corresponding carriers in the drive section will be damaged due to the speed of the system.

3.1.2 Current Solution

The conveyor has a fence around it that prevents people from reaching the section mentioned above. Nonetheless, a safety tunnel (see figure 3.3) was added to the drive section of the system which does not allow the user to approach the end of the conveyor (see figure A1). Below the safety tunnel, in the end of the system, a container is present (for rejected parcels) which can only be removed if the SCO is not running.

This approach works, however, it is expensive:

- Money - the safety tunnel is an extra part that can be removed if the new sort beam design solves the "crocodile mouth" problem;

- Time - every time a rejected parcel falls into the container in the end of the system, the sorter has to be stopped in order to remove the container and get the rejected parcel. Since the SCO can sort 11000 parcels per hour, each minute that the conveyor is not operational equals to 183 parcels that were not sorted.

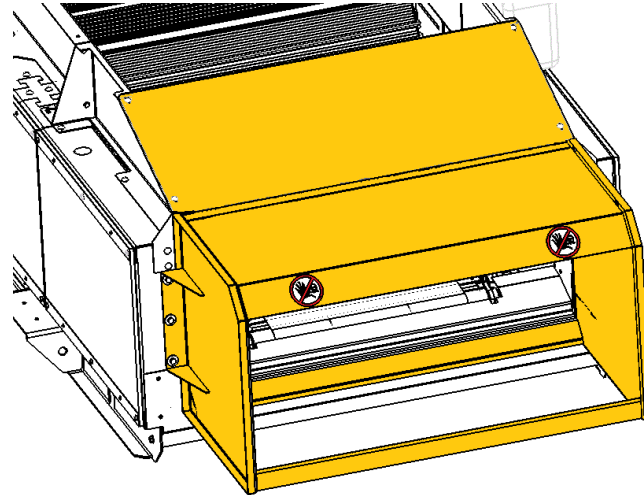

Figure 3.3: Safety tunnel.

Part III

Methodology and Development

Chapter 4

Methodology

In the beginning of the project, a Plan of Action (see figure 4.1) was established. The final goal of the plan was to develop a solution and a functional prototype. However, throughout the project, some stages were more time consuming than expected. Consequently, the plan suffered small changes during the internship.

4.1 Plan of Action

The plan had the following stages:

1. Problem statement: identify the main problem;
2. User requirement specifications (URS): define problems, requirements and approach to a new design;
3. Developing concepts: turning ideas into drawings;
4. Decision analysis: developing a morphological analysis and decision matrix to decide which concept should be developed further ahead;
5. Conceptual model (CAD): design a 3D model of the chosen concept with working design features. Afterwards, the model would undergo through a Finite Element Method (FEM) and motion analysis. Technical drawings would be done in this stage;
6. Functional model (prototype alpha): develop a test plan that the prototype has to follow and then order the model and extra parts, if necessary. After the prototype arrival, the test plan should be followed. Further on, its behaviour would be analysed and its design reviewed;
7. Prototype beta: this stage followed the same procedure as the last one, if the prototype needs to be modified;
8. Prototype analysis: after testing different brackets on both prototypes, it was clear that its behaviour was more complex than expected. Therefore, a multi-body mathematical model was elaborated to simulate its mechanism;
9. Prepare final documentation.

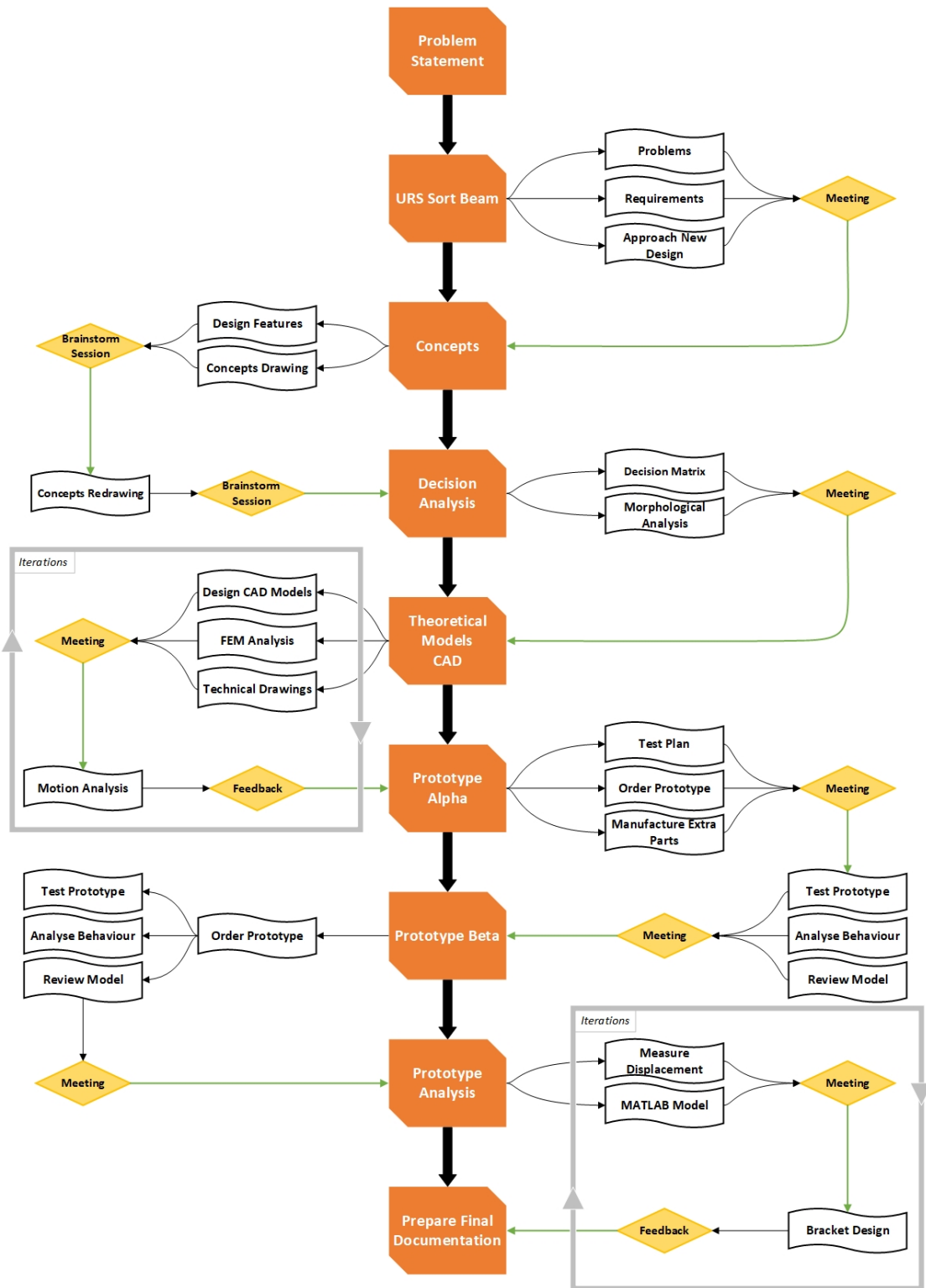

Figure 4.1: Plan of action diagram.

4.2 Requirements

Bellow an extensive list of requirements is defined. The most important requirements were named *Primary Requirements*.

4.2.1 Primary Requirements

1. The sort beam must be able to sort items to both sides, right and left;
2. The sort beam must be able to handle PHUs with the following characteristics:
 - $50 < \text{width [mm]} < 460$;
 - $5 < \text{height [mm]} < 460$;
 - $50 < \text{length [mm]} < 550$;
 - $0.05 < \text{weight [kg]} < 15$.
3. The sort beam should stay on top of the carriers throughout the system, especially in the drive section of the SCO – it should not separate itself from the carriers bellow;
4. The sort beam must stay inside a circumference with a radius of 330 mm with the center of the gear shaft in the drive section of the system as referential (see figure 3.2a);
5. The sort beam should bend as much as 37.5° in the drive section of the sorter (see α in figure 4.2);
6. It must come back to its neutral shape after it bends, i.e. after it goes through the drive section of the system – it has to go from 37.5° to -6° , only after the negative bending section, the sort beam will be in the horizontal position (see β in figure 4.2).
7. Its interior dimensions have to be $495 \times 162 \times 43.3$ mm in order to fit on top of a divert shoe;
8. Both sorting sides (surfaces that touch the parcel during the sorting event) must not interfere negatively with the parcel, i.e. the parcel cannot be stuck in the sort beam;
9. Brushes (or other equipment) have to be attached to the sort beam in order to avoid any parcel of going under the sort beam – the system must be able to sort thin parcels, like letters. Brushes will also help cleaning the carrier during the sorting event;
10. The sort beam must be fixed only to one divert shoe on the top surface;

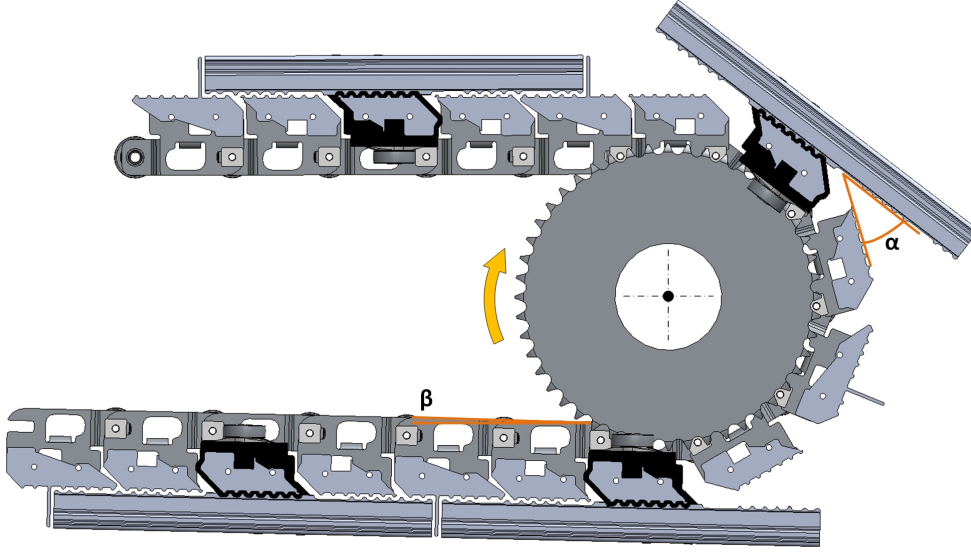

Figure 4.2: Sort beam angles in the drive section.

4.2.2 Secondary Requirements

1. The sort beam is the only part of the system that should be redesigned;
2. The sort beam replaces 3 or 4 shoes – any parcel within 3 or 4 consecutive pitches (space on top of a carrier) will be sorted by one sort beam (see figure 2.3);
3. The sort beam should work correctly between the following range of temperatures and humidity, respectively: 0°C to 40°C and 10% to 90%;
4. Its lifetime should be 10 years (or 1341222 cycles) for a 200 meters sorter (longest sorter):

$$1 \text{ cycle} \longrightarrow 200 \times 2 = 400 \text{ [m]}$$

$$v_{\text{sorter}} = \frac{d}{t} \iff 1.7 = \frac{400}{t} \iff t \approx 235.29 \text{ [s]}$$

$$t_{10 \text{ years}} = 315576000 \text{ [s]}$$

$$n_{\text{cycles}} = \frac{t_{10 \text{ years}}}{t_{1 \text{ cycle}}} \iff n_{\text{cycles}} = \frac{315576000}{235.29} \approx 1341222 \text{ [cycles]}$$

5. The sort beam must be designed to always be in a horizontal position pointing in the direction of the sorter movement;
6. It must handle accelerations from 0 m/s² to 0.5 m/s² in the direction of the conveyer movement;
7. It must handle accelerations from 0 m/s² to 78.4 m/s² that is equivalent to 147 kg of force applied on the sort beam and respective divert shoe when the switch frame

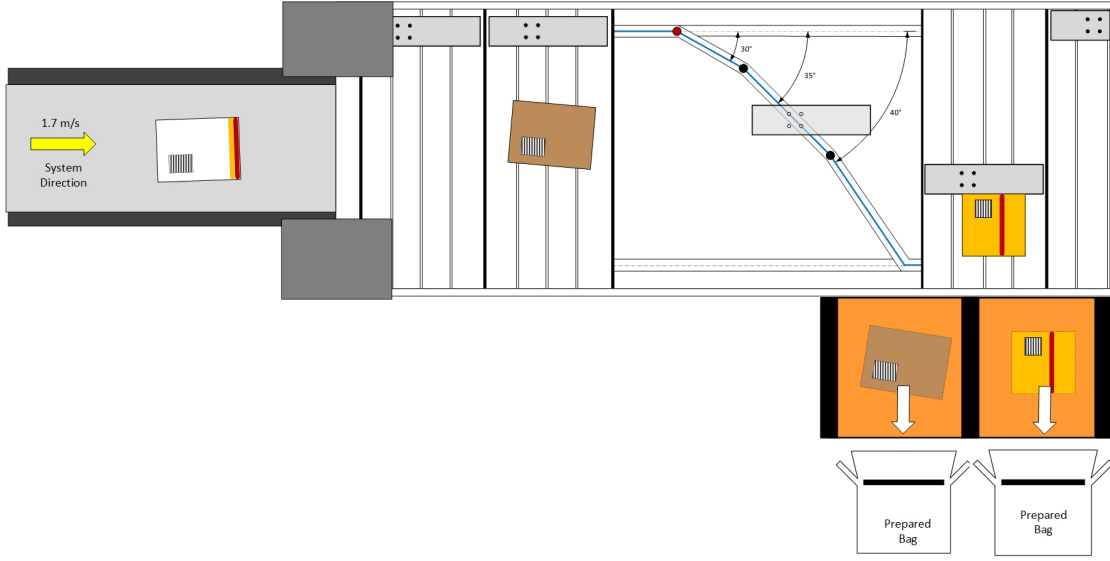

Figure 4.3: Top view of the SCO with switch frame angles.

is activated. The movement direction changes from 0° with the sorter movement to 30° – sorting process (see red point in figure 4.3):

The acceleration is larger in the red point because it goes from 0° to 30° , while in the black points it increases only 5° per point. The section that the sort beam goes from 40° to 0° is not the most dangerous because the parcel is not stationary, i.e. the parcel is already moving. In the red point, the sort beam will be under larger forces due to the presence of the stationary parcel (see figures 4.4 on the next page and A2 in annex).

$$\vec{v}_0 = 1.7 \text{ m/s}$$

$$\cos(\theta) = \frac{\vec{v}_0}{\vec{v}_1} \iff \cos(30^\circ) = \frac{1.7}{\vec{v}_1} \iff \vec{v}_1 = 1.96 \text{ [m/s]}$$

$$\cos(\beta) = \frac{\vec{v}_0}{\vec{v}_2} \iff \cos(35^\circ) = \frac{1.7}{\vec{v}_2} \iff \vec{v}_2 = 2.08 \text{ [m/s]}$$

$$\cos(\gamma) = \frac{\vec{v}_0}{\vec{v}_3} \iff \cos(40^\circ) = \frac{1.7}{\vec{v}_3} \iff \vec{v}_3 = 2.22 \text{ [m/s]}$$

$$\sin(\theta) = \frac{\vec{v}_{1y}}{\vec{v}_1} \iff \sin(30^\circ) = \frac{\vec{v}_{1y}}{1.96} \iff \vec{v}_{1y} = 0.98 \text{ [m/s]}$$

$$\vec{v}_{1y} = \frac{y}{t} \iff 0.98 = \frac{0.0122}{t} \iff t = 0.0125 \text{ [s]}$$

$$\vec{a}_{1y} = \frac{\vec{v}_{1y}}{t} \iff \vec{a}_{1y} = \frac{0.98}{0.0125} \iff \vec{a}_{1y} = 78.4 \text{ [m/s}^2\text{]}$$

$$m_{\text{beam+accessories}} \approx 1.7 \text{ kg} \iff \text{Safety Factor} = 200\%$$

therefore $m_{\text{beam+accessories}} = 3.4 \text{ kg}$

$m_{\text{heavy parcel}} = 15 \text{ kg}$

$$F = m \times a \iff F = (3.4 + 15) \times 78.4 \iff F = 1442.56 \text{ [N]} \approx 147 \text{ kg}$$

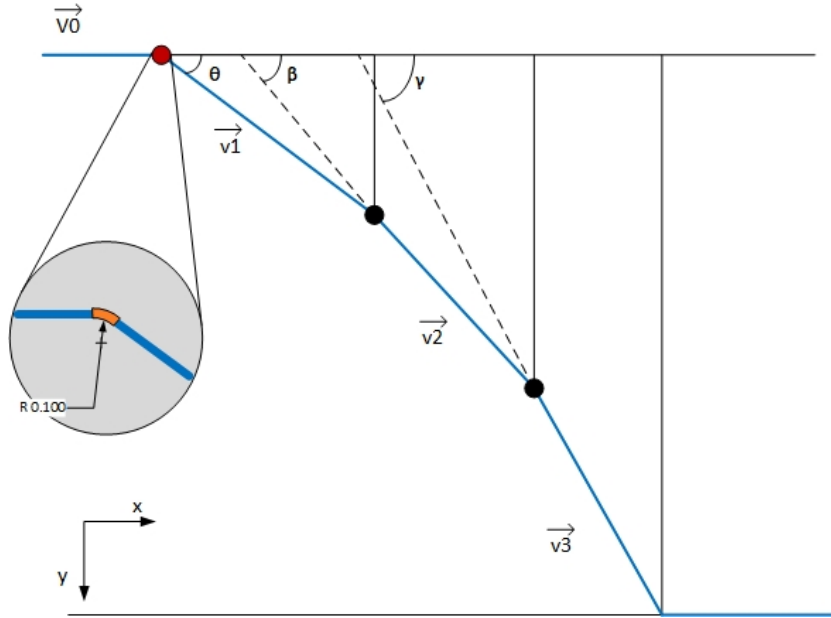

Figure 4.4: Simplified switch frame angles.

8. The screws that fix the sort beam to the shoe have to handle the sort beam in place before, during and after the sorting event;
9. The gap between the carrier flange and the corresponding end of the sort beam has to be equal or less than 5 mm (see figure A3 in annex);
10. The top surface of the sort beam should not be higher than the side guarding's height (250 mm above the carrier level);
11. The sort beam should be made of the least parts possible (ideally, 1 part only);
12. The sort beam has to bend in 0,31 s, i.e. the sort beam has to be fully bended when it reaches a quarter of the gear in the drive section:

$$\begin{aligned}
 r &= 330 \text{ mm} \\
 \omega &= \frac{\vec{v}}{r} \iff \omega = \frac{1.7}{0.330} \iff \omega = 5.061 \text{ [rad/s]} \\
 \omega &= 2\pi \times f \iff 5.061 = 2\pi \times f \iff f = 0.81 \text{ [Hz]} \\
 f &= \frac{1}{T} \iff 0.81 = \frac{1}{T} \iff T = 1.24 \text{ [s]} \\
 \frac{1}{4}T &= 0.31 \text{ [s]}
 \end{aligned}$$

13. Maximum horizontal/sorting direction deformation must be 10 mm during the sorting event. Afterwards, it should come back to its normal shape (elastic behaviour).

Chapter 5

Development

After specifying the requirements, fully understanding the problem and the system itself, 18 ideas/concepts were hand-drawn with the help of a morphological analysis.

5.1 Morphological Analysis

The morphological analysis combines subsolutions to find a combination of theoretically conceivable concepts that will form a total solution to the problem [24].

Regarding the redesign of the sort beam, the problem must be subdivided: each division (or parameter) must be essential for the solution of the problem. Afterwards, theoretical possible realisations (or principles) are inventoried for each parameter. Moreover, the separation between the generation of solutions and the choice between them is the approach looked for with the morphological analysis [23].

The parameters given to the morphological analysis are shown in table 5.1.











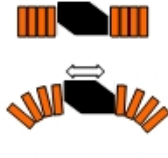

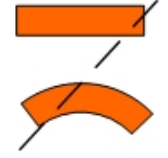
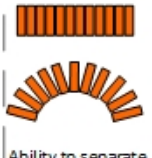

The options were chosen with the following reasons: the motor inside the shoe was not selected due to its price compared to the other solutions, the external force solution was not chosen due to the wear that it was going to cause on the sort beam and the extra noise that it would generate, the magnets were also not an option because the carrier needed to be changed and metal products might be sorted. Choosing between attaching to the carrier in front or in the back was based on the time that the sort beam was going to bend – if it is attached to the carrier in the back, it is going to bend later than if it is attached to the carrier in front. Therefore, the chosen bending mechanism was the one that attaches the sort beam to the carrier in front.

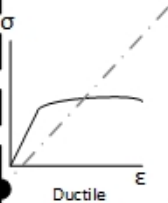
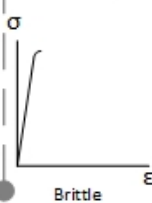
Choosing between the second, third and fourth parameters was more straight forward since one requirement mentions that the sort beam should be made out of the least parts possible. Therefore, to satisfy that requirement the sort beam should have only 1 part. If it has only one part, the sort beam cannot decouple, then it has to be flexible. In order to be flexible, the material should be ductile.

The choice for the outer shape of the sort beam was based on the sorting procedure. If the sort beam has any other shape rather than rectangular, it could sort a parcel in the wrong direction. Therefore, it should be rectangular – flat side surfaces.

Last but not least, a requirement states that the sort beam should be attached to the divert shoe only on the top surface. Accordingly, the first principle for the last parameter is preferred.

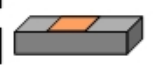
Table 5.1: Morphological analysis.

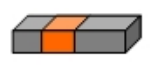
		Principles				
		- A -	- B -	- C -	- D -	- E -
Parameters	Bending Mechanism	 Motor inside shoe	 Attach to carrier in front	 Attach to carrier behind	 External interaction	 Magnets
	Bending	 Ability to bend	 Ability to separate in parts			
	No. Parts	 1 part	 More than 1 part			
	Material	 Ductile	 Brittle			
	Shape from Top	 Rectangular	 Triangular	 Circular	 Octagonal	
	Side Surface	 Covered	 With openings			
	Shoe Attachment	 Top surface	 Side surfaces	 Top and side surfaces		

The black dashed line defines the best possible solution and the grey lines refer to secondary (not ideal) solutions – the grey dashed lines represent the solution for a fragmented sort beam. The bending mechanism should be the same but the ability to bend is replaced by the ability to separate in multiple parts. Therefore, it was going to have more than 1 part and the material could be either ductile or brittle.

5.2 Concepts

Some of the created concepts were based on the same idea or mechanism. Therefore, bellow 6 main ideas (different mechanisms) for the new sort beam are presented.

New ideas and designs were divided in 2 groups: fragmented – sort beam made out of more than 1 part – and flexible concepts – sort beam made out of 1 part. The flexible concepts may be preferred due to the number of parts that they would be made of – a concept that is made out of several parts will take some time to assemble while a concept that is made out of 1 part only takes less time to mount on the divert shoe. Nonetheless, the first one should also be analysed since it may help creating new ideas for a flexible sort beam.

5.2.1 Fragmented Concepts

The idea behind the following concepts is bending/separating through hinges and/or through a coupling mechanism.

Concept 1 - Hinge Mechanism

This concept is attached on the bottom surface to the main body through a hinge. Its working principle (see figure 5.1) is the following: the tip of the sort beam should be attached to the carrier bellow in order to go down at the same time as the carrier.

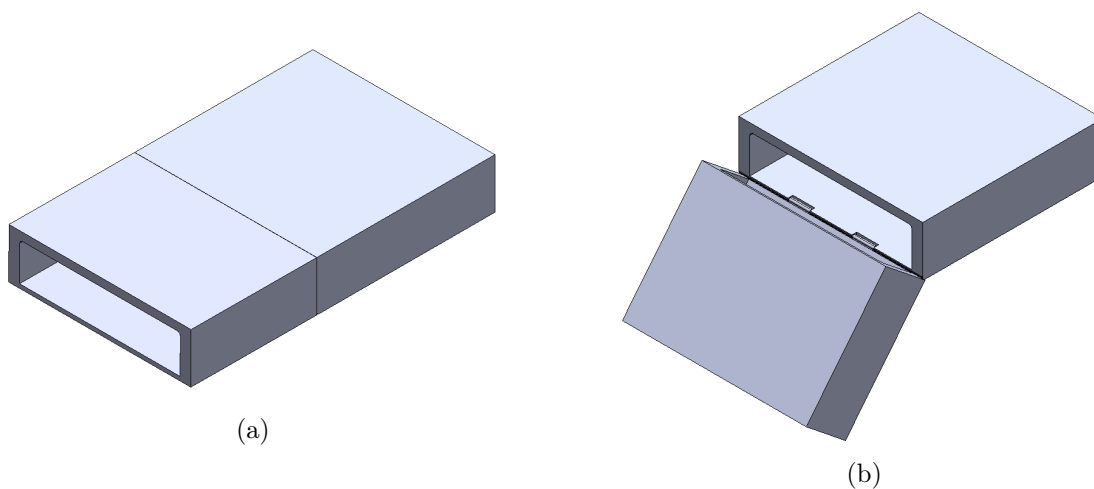

Figure 5.1: Representation of the hinge mechanism concept.

Concept 2 - Coupling Mechanism

This model promotes separation and easier bending (see figure 5.2). The model is divided in several layers. These layers are attached to each other but they can slide forward from the initial position. Since the thickness of the layers is smaller than the thickness of the full sort beam, it is easier to bend those parts individually, if the material is flexible enough (see figure 5.2b). This behaviour is explained by the deflection equation 5.1 [4]:

$$\delta = \frac{F.L^3}{4.b.t^3.E} \quad (5.1)$$

where δ is the deflection of a beam, F the applied force, L the beam's length, b and t are the width and thickness of the beam, respectively, and E is the Young Modulus of the material. A brief analysis of the equation indicates that for the same material, same applied force, same length and width of the beam, if the thickness decreases, the deflection will increase exponentially.

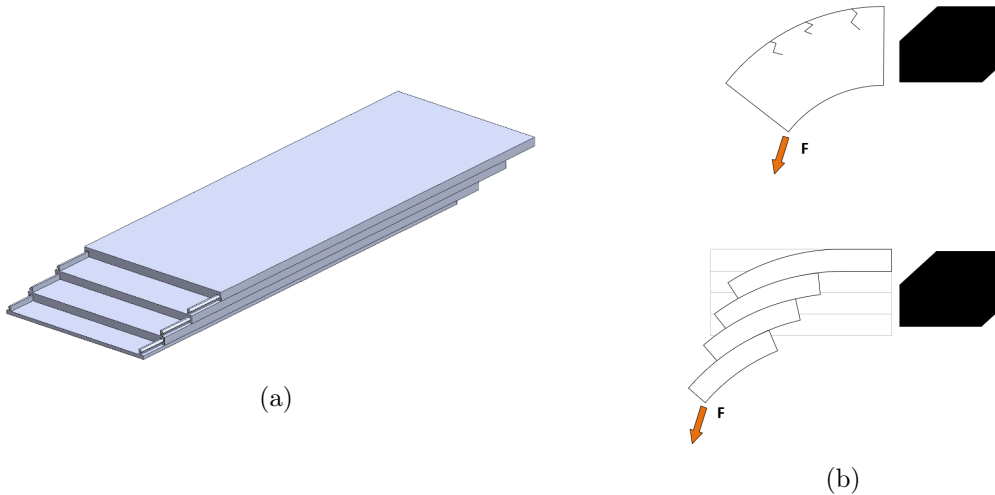

Figure 5.2: Representation of the coupling concept.

The model would work the following way: the bottom layer should be attached to the carrier in front of the one with the shoe. When that carrier starts to go down, it would pull that same layer out of the main body of the sort beam which will then pull the layer on top of it and so on.

5.2.2 Flexible Concepts

To generate flexible concepts, more creativity and brainstorm sessions were needed to discuss ideas. Like the *Fragmented Concepts*, some ideas were similar.

Concept 3 - Spring Mechanism

The model is divided in as many sections as needed and those parts are linked with a thin structure which acts like a spring (see figure 5.3).

The springs will allow the sort beam to extend which would allow at the same time the sort beam to bend in those specific sections. The spring should be strong enough

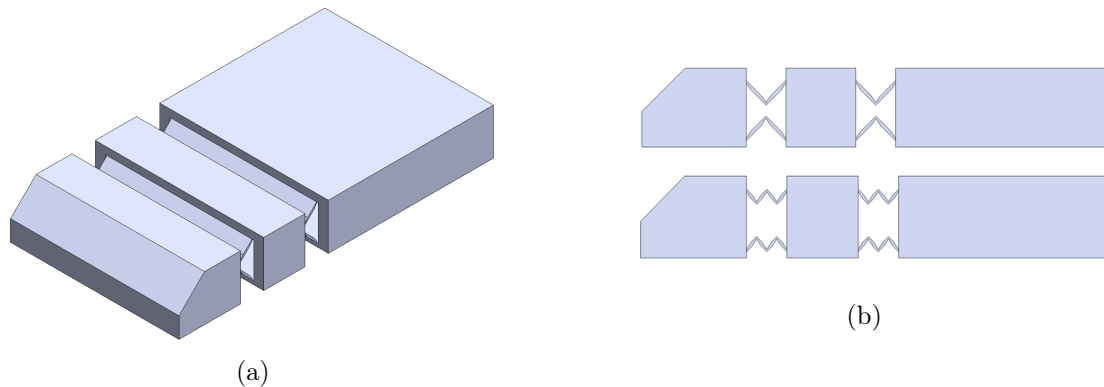

Figure 5.3: Representation of the spring concept.

to pull the sort beam back together to its flat shape. The tip of the sort beam must be attached to a carrier to activate the mechanism.

Concept 4 - Half Spring Mechanism

The half spring mechanism (see figure 5.4) allows the sort beam to bend (similar mechanism to the previous one). The top surface has a cover in order to prevent parcels of getting inside the sort beam while it is in the sorting position. The side surface of the beam has several cuts. Those cuts create small trapeziums which have their bottom edge attached to the main body of the concept while the other edges are free. Therefore, these trapeziums can rotate through the attached edge if the sort beam bends. They will open/rotate to the outside of the concept when it starts to bend, i.e. if the bottom surface of the concept was compressed, the reaction of these trapeziums would be folding out.

The tip of the sort beam must be attached to a carrier to activate the mechanism.

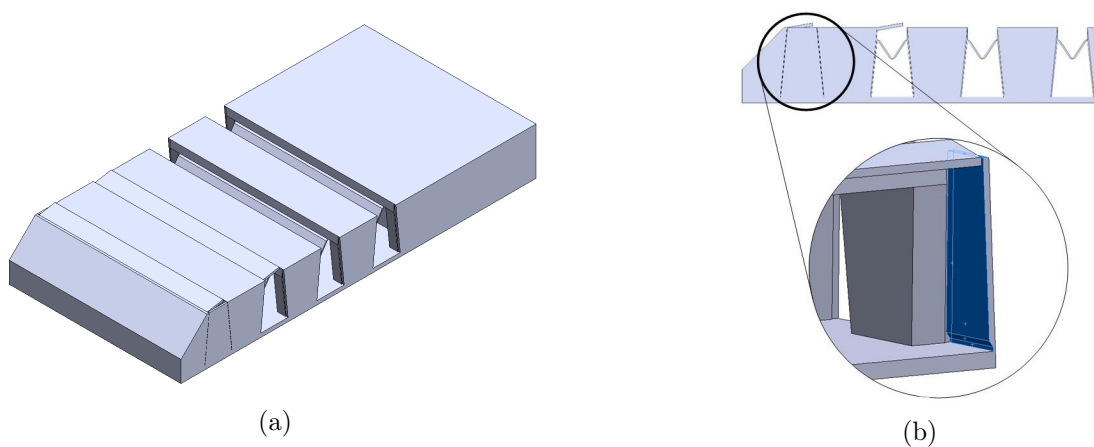

Figure 5.4: Representation of the half spring concept.

Concept 5 - Butterfly Mechanism

This concept has several edges made out of a thin film where they are meant to bend, working like hinges (see figure 5.5).

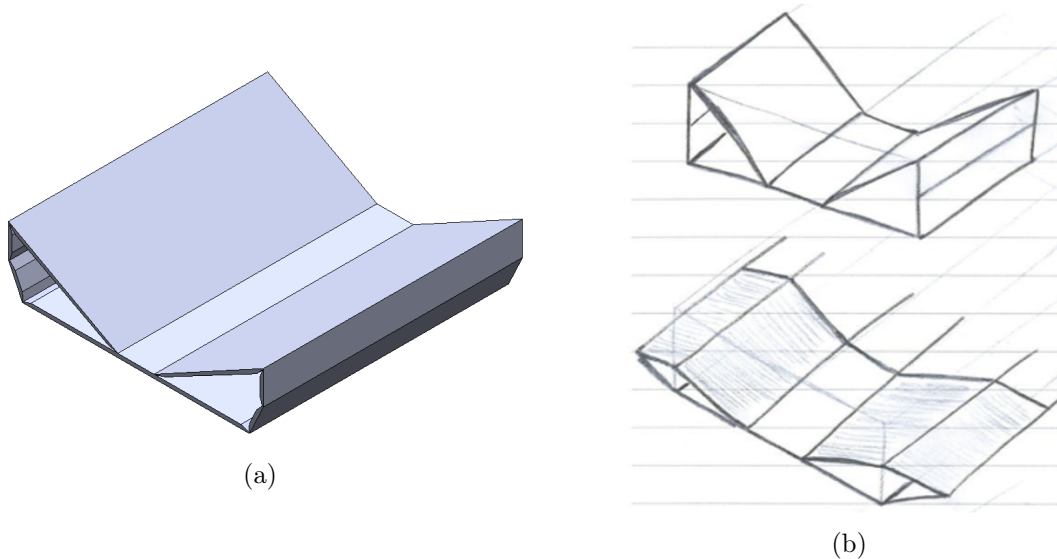

Figure 5.5: Representation of the butterfly concept.

This model was designed in a way that when it is bending, its height reduces significantly. The top surface would almost touch the bottom surface, as it is possible to see the representation in figure 5.5. The bottom surface must be attached to a carrier, so when it starts to go down, it will pull the bottom surface which in turn will oblige the top surface to lower its height.

Due to the flexible side surface design of this model, it has an important feature that is gentle handling of parcels.

Concept 6 - Fin Ray Mechanism

This concept is based on the Fin Ray[®] effect (see figure 5.6) [14].

The Fin Ray[®] structure can adapt flexibly (depending on the material) to the most varied shapes [10]. The middle square represents the divert shoe in which the concept would be attached to. The triangular shape is attached to the section that sits on top of the shoe only on the bottom surface.

This model works on the following way: to bend the concept, the top surface of the triangle with flanges inside must be pushed forward while the bottom surface is fixed. When the top surface is being pushed, the paralleled flanges inside the model will push the bottom surface down, making the model bending over any shape below itself.

5.3 Decision Analysis

The main goal of the decision analysis is to choose the 3 best concepts: instead of analysing in detail 18 concepts, 3 will be chosen and then extensively analysed, ending

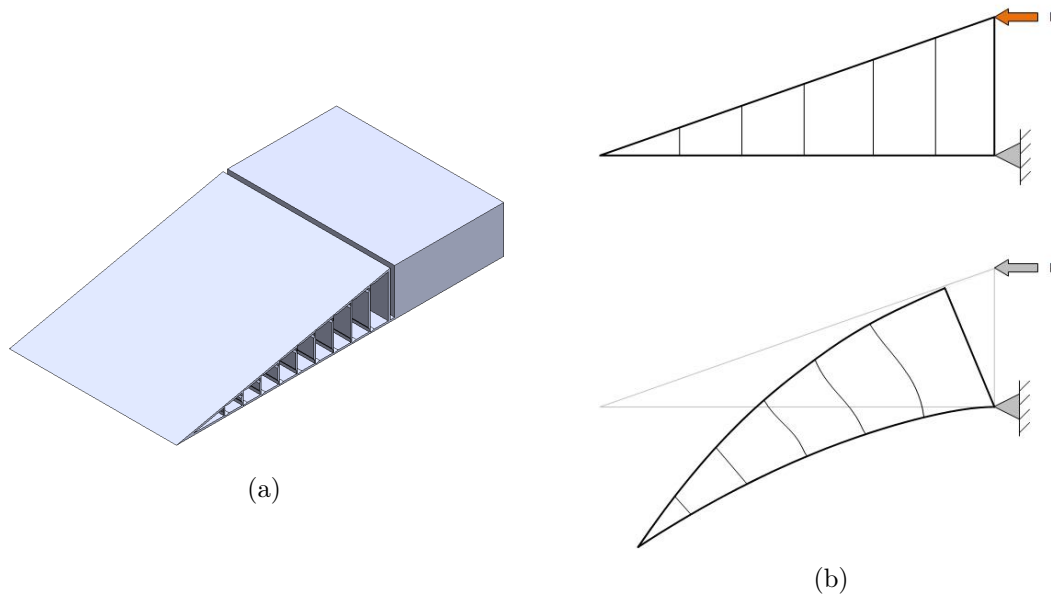

Figure 5.6: Representation of Fin Ray[®] concept.

up with a winning concept [22].

The decision analysis was done based on an adapted Cause & Effect matrix [27]. The developed matrix (see table 5.2) is similar to a "funnel" tool that is used to focus on the most important factors of influence, i.e. requirements – it shows the strength and relationship between the factors of influence [17].

The requirements weight was from 1 to 10 and the grades to evaluate the concepts were 0, 1, 3 or 9.

After giving all the inputs to the matrix, the columns *Total*, *Concept Analysis* and *Rank* are automatically calculated. The *Total* score is the sum of all the grades multiplied by the corresponding requirement importance. The *Concept Analysis* is presented in percentage and it represents how close a concept is to the *Perfect* one, which has 100% (since all grades are 9). The *Rank* is based on the scores previously explained: the concept with the highest score will be ranked as 1st, the concept with the second highest score will be ranked as 2nd and so on.

The 3 last lines of the matrix, *Lower Spec*, *Target* and *Requirement Analysis*, are simply to help the developer analyse if the *Key Requirements* are being fulfilled by the concepts. In this case, the *Lower Spec* for the *Key Requirement* "Bending" is the sum of the grade 3 times 10 (requirement importance) times 18 which is the number of concepts (less the *Perfect* one). The *Target* value follows the same line of thought of the *Lower Spec* but with the grade 9. The *Requirement Analysis* is the difference between the *Target* and *Total* values. Hence, the value in the last line of the matrix should be as close as possible to 0 but, if not possible, always less than the *Lower Spec* value.

5.3.1 Concept Analysis Matrix

Conclusively, the Concept Analysis matrix of the SCO Sort Beam Redesign was complete and the result is shown in table 5.2.

Table 5.2: Concept analysis matrix.

			Rating Requirement Importance: →											
			10	9	7	10	7	6	8	10	8			
			1	2	3	4	5	6	7	8	9			
			Key Requirements: →											
			Bending	Bending Smoothness	Bending Time	Sorting Event	Side Surface	Life Time	Replacement	Production Cost	Assembly Time	Total	Concept Analysis	Rank
Nr.	Concept	↓ Concept Main Feature:												
1	1	Easy bending	3	1	0	9	9	3	9	3	3	336	50%	15
2	1.1	Easy bending	3	3	3	9	9	3	9	3	3	375	56%	11
3	1.2	Easy bending	3	1	1	9	9	3	3	3	3	295	44%	18
4	4	Easy decoupling	3	3	9	9	9	3	1	3	3	353	52%	13
5	4.1	Easy decoupling	3	9	9	9	9	9	1	3	3	443	66%	7
6	6	Easy bending	3	9	9	3	0	1	9	9	9	444	66%	6
7	1.3	Easy bending	3	3	3	9	9	3	9	3	3	375	56%	11
8	8	Easy bending + fast decoupling	3	9	9	9	9	9	3	3	3	459	68%	4
9	8.1	Easy bending + fast decoupling	3	9	9	9	9	9	3	1	3	439	65%	8
10	8.2	Easy bending + fast decoupling	3	9	9	3	3	3	3	1	3	301	45%	17
11	Finger Tip	Fast bending + fast decoupling	3	9	9	9	9	3	1	3	1	391	58%	9
12	Excavator Arm	Easy decoupling	3	3	9	9	9	3	1	3	1	337	50%	14
13	13	Fragmented	3	3	9	9	9	1	1	3	1	325	48%	16
14	Spring	Bending	9	3	9	1	3	1	9	3	9	391	58%	9
15	Sliding	Fragmented	9	3	9	9	9	3	9	9	3	537	80%	2
16	Concept 3	Bending	9	3	9	9	9	1	9	1	3	445	66%	5
17	Butterfly	Bending	9	3	9	9	9	1	9	3	9	513	76%	3
18	Fin Ray	Bending	9	9	9	9	1	9	9	3	9	559	83%	1
	Perfect	Bending	9	9	9	9	9	9	9	9	9	675	100%	
Total:			930	909	994	1510	994	462	856	690	648			
Lower Spec			540	486	378	540	378	324	432	540	432			
Target			1620	1458	1134	1620	1134	972	1296	1620	1296			
Requirement Analysis			690	549	140	110	140	510	440	930	648			

The 3 best concepts are the concepts number 18 (named *Fin Ray*, which got the 1st place), 15 (named *Sliding*, which got the 2nd place) and 17 (named *Butterfly*, which got the 3rd place).

The *Fin Ray* concept is based on the Fin Ray[®] effect [14]: this structure adapt itself flexibly to any shape. Therefore, it can bend the required angle and adapt its shape to anything bellow itself, in this case, the carrier (see figure 5.7a).

The *Sliding* concept has a (de)coupling mechanism that promotes separation (see figure 5.7b). When different layers separate from each other, the thickness of the part which will bend is be smaller what makes the bending event easier to happen (see explanation in chapter 5.2.1).

The *Butterfly* concept has thin parts of its body on the side and top surfaces, which work like hinges (see figure 5.7c). Because it is hollow, when the bottom surface is pulled down, the side surfaces will pull the top surface also downward. Due to the presence of the thin sections (hinges) the model will fold, making it easier to bend.

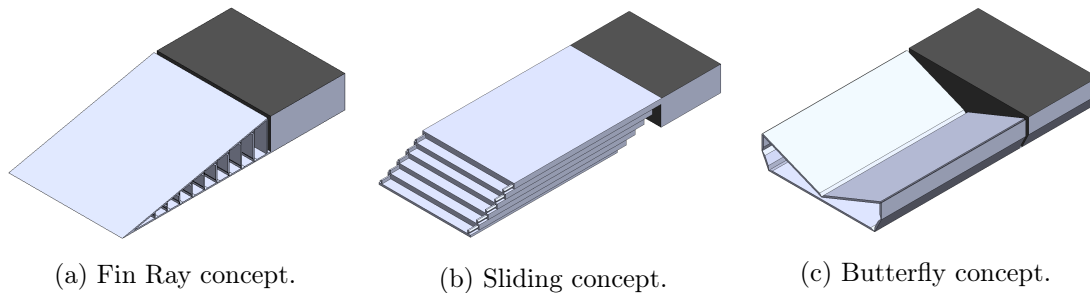

Figure 5.7: Chosen concepts.

5.3.2 Detailed Analysis

The 3 concepts mentioned above were then meticulously analysed in order to choose the one which would be developed and tested.

Hence, an in depth decision analysis document was prepared to finally come up with the winning concept (see table A2 in annex). The winner concept was the *Fin Ray*.

5.4 Concept Development

Since the goal of the first prototype is to have a proof of concept, it is important to have a concept that validates the adapted mechanism.

The *Fin Ray* concept changed its shape throughout its development to optimise not only the performance of the bending act but also the sorting event [20].

The simulation used during the development was the static one and the applied material, low density polyethylene (LDPE), behaved as linear elastic isotropic – this material was chosen in first place due to its mechanical properties, especially flexibility [5] [18]. The used mesh was made out of tetrahedrals with a total of 13722 elements. The section that represents the shoe was fixed and the force was applied on the top of the last flange (see figure 5.6b).

The first feature to be changed was the number and angle of the flanges inside the sort beam. If the flanges inside the model have a certain angle, the displacement of the tip of the beam can increase up to 30% [3].

The simulations presented in figure 5.8 show the difference between a model with vertical flanges and another with fewer flanges and with a different orientation. The simulations were done with a force F of 50 N applied on the top of the model with a horizontal direction (as explained in figure 5.6b).

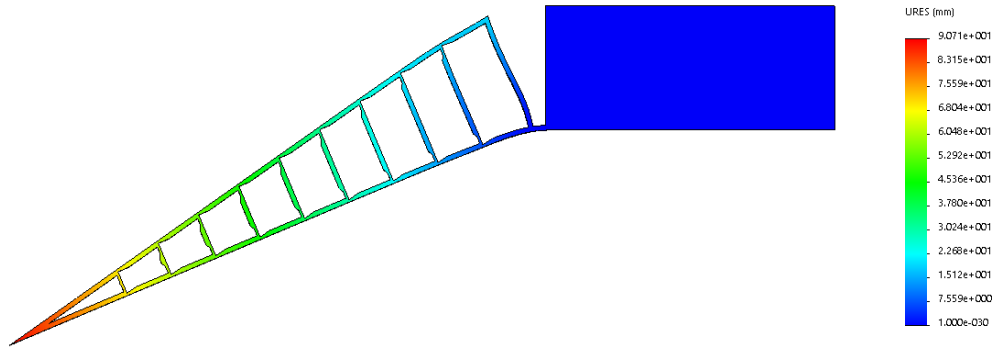

(a) Vertical flanges.

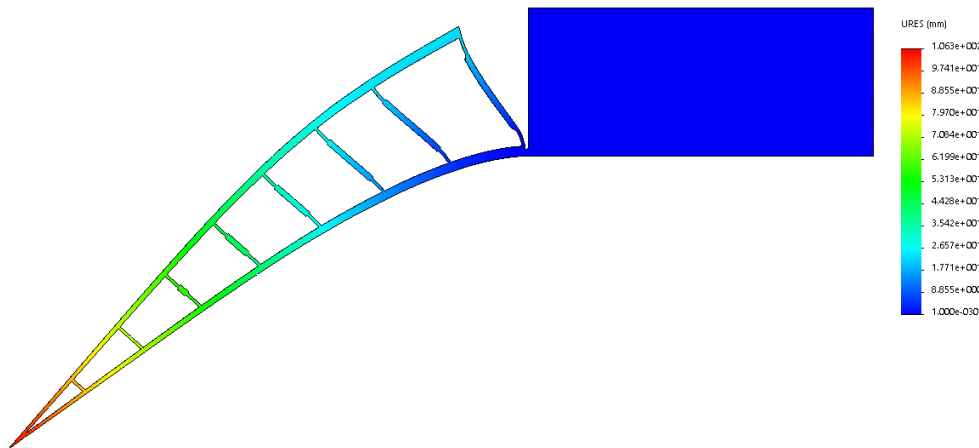

(b) Tilted flanges.

Figure 5.8: FEM simulation displacement results for vertical and tilted flanges.

The next design feature that changed was the thickness of the top and bottom surfaces. Because the tip of the beam is more difficult to bend and because the applied force is on the other end of the sort beam, the thickness was increased in the later section and decreased on the tip of the beam [7] – smaller the thickness, larger the deflection [4].

Furthermore, the top surface was flat/straight and it changed to curved. This feature was applied having in mind an important characteristic: if the sort beam is sorting a parcel that was placed on its tip, the parcel may roll over the sort beam because the touching area is sparse. With the curved top surface, the touching area (side surface) increased. Also, instead of a sharp edge, the tip was filled with material which increases the strength of that section.

The number, orientation, shape and spacing between flanges changed from iteration to iteration regarding the results and analysis of FEM simulations (additional simulations in figure A4 in annex) [9].

Close to the last design iteration, the section of the sort beam that would be attached to the divert shoe was adapted to its shape and 4 holes were made on the top surface to fit screws.

When the FEM results started to be very similar, i.e. identical stresses and displacement, the iteration process stopped and the model was ready to become a prototype (see figure 5.9).

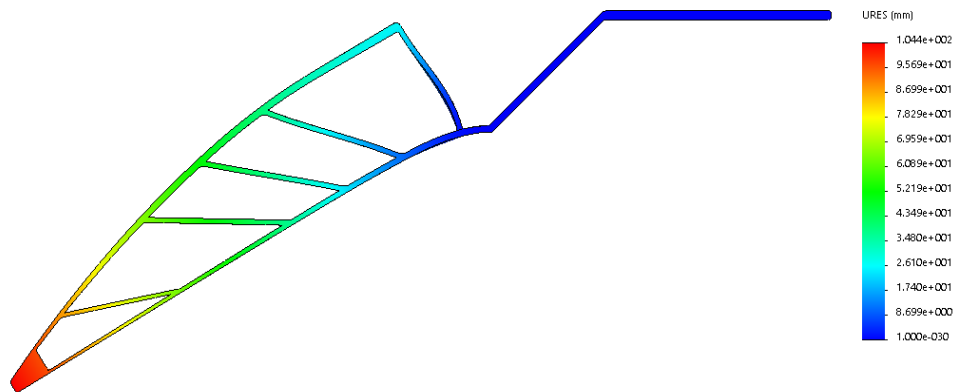

Figure 5.9: FEM simulation displacement results for the last iterated model.

The final design of the concept phase is presented in figure 5.10.

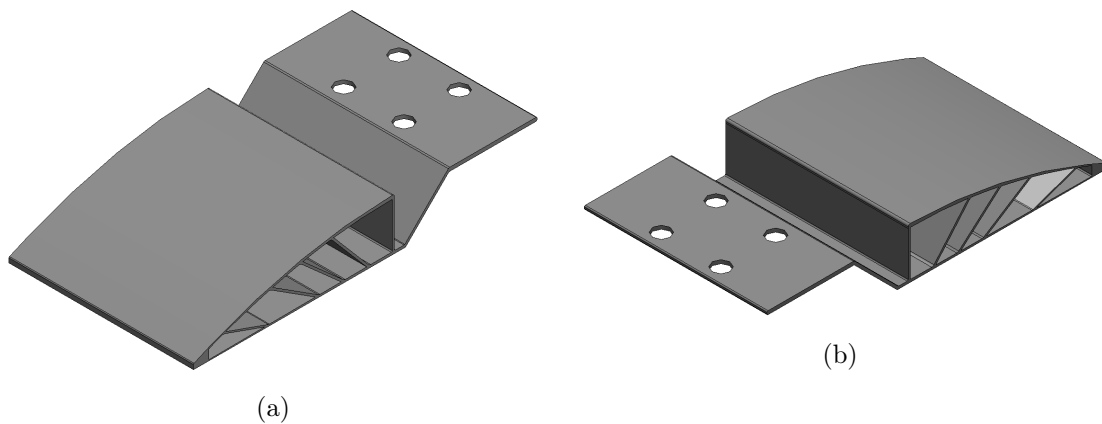

Figure 5.10: CAD overview of prototype alpha.

Part IV

Functional Prototypes

Chapter 6

6.1 Prototype Alpha

The concept suffered one small change before being produced – a small hole on the back of the model was made in order to fit the mechanism that applies the required force to bend the model (see figure 6.1). This mechanism is explained in the next chapter.

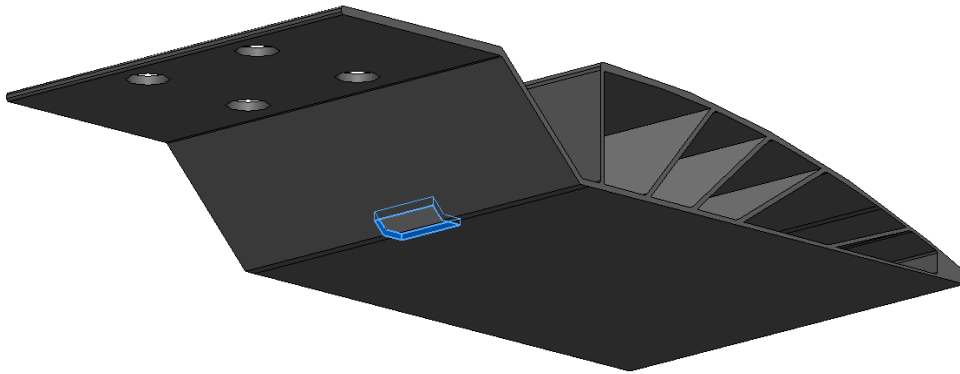

Figure 6.1: Bracket hole.

The concept was ordered to an external company. The technology used to produce the model was SLS (Selective Laser Sintering) and the material that the company advised to use was nylon (polyamide, PA 6). Even though it was asked to change the material, the external company argued that it was going to behave the same way as the wanted material (LDPE).

At this stage, only the section in front of the divert shoe was developed because the design used in that section should be the same as the one in the back section. Thus, it is cheaper to test the behaviour in only one of these parts.

6.1.1 Bracket

The mechanism that pushes the top surface of the sort beam forward was also developed. This mechanism, named bracket, was manufactured in the company facilities.

Components

The bracket is made out of 2 parts: one that sits in between the hole in the back section (see figure 6.2a) and another which is fixed to the sort beam (see figure 6.2b). The assembly of the sort beam with the bracket components is shown in figure 6.3.

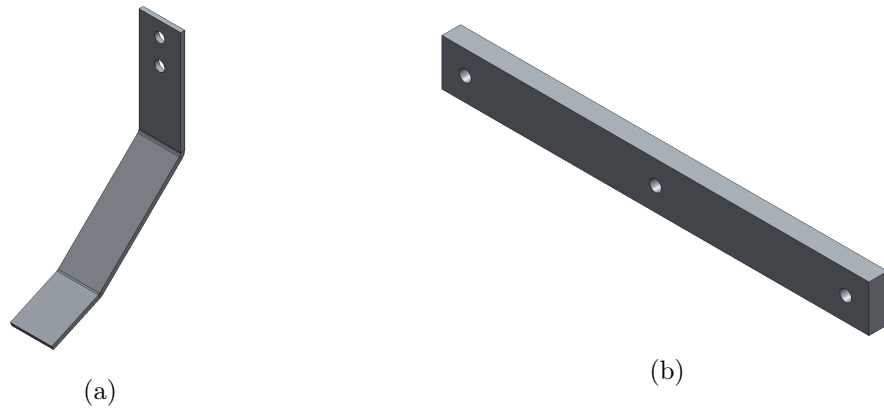

Figure 6.2: Bracket components.

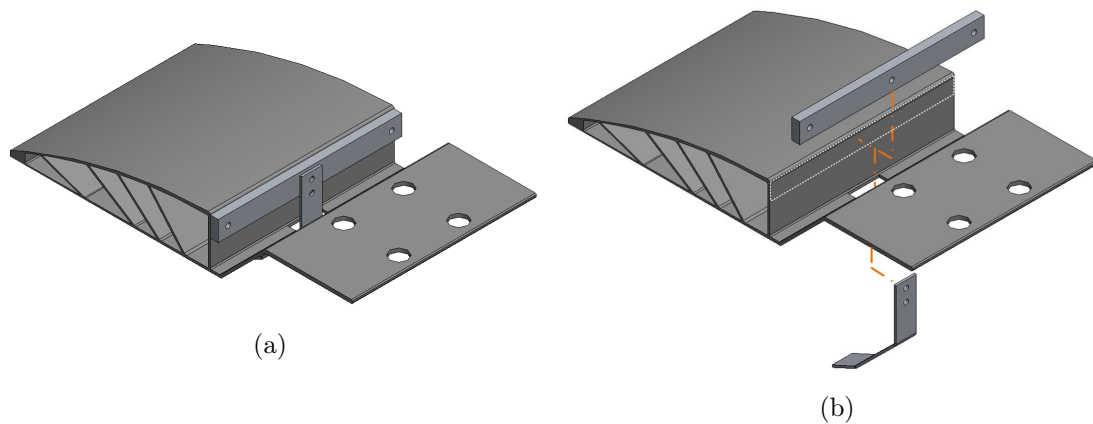

Figure 6.3: Bracket assembly.

Mechanism

When the sort beam is reaching the drive section of the SCO, the bracket will be pushed down by the carrier in front of the divert shoe. When this happens, firstly the bracket will be pushed against the divert shoe and then it will mimic the behaviour of a hinge, rotating around the point that is touching the shoe and pushing the top surface of the sort beam forward (see figure 6.4).

Moreover, four new requirements entered the requirement list:

1. The bracket must be able to bend the sort beam completely;
2. The bracket must not must not interfere with the sort beam when it is sorting a parcel;

3. The bracket should not touch any carrier or shoe when the sort beam is in its neutral position;
4. The bracket must not cause friction/wear in other parts of the system.

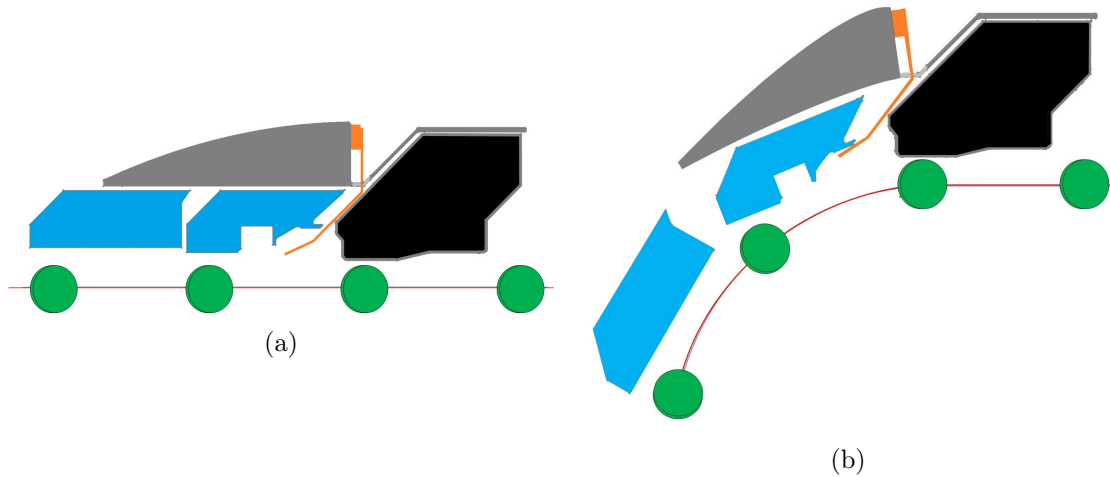

Figure 6.4: Illustration of the bracket mechanism.

6.1.2 Physical Test

Due to the fact that the advised material was not flexible enough, the prototype was not able to bend. Hence, physical changes were made in order to make it suitable for a physical test: part of the flanges inside the prototype was removed and the vertical flange, the one that holds the bracket, was cut (see figure 6.5).

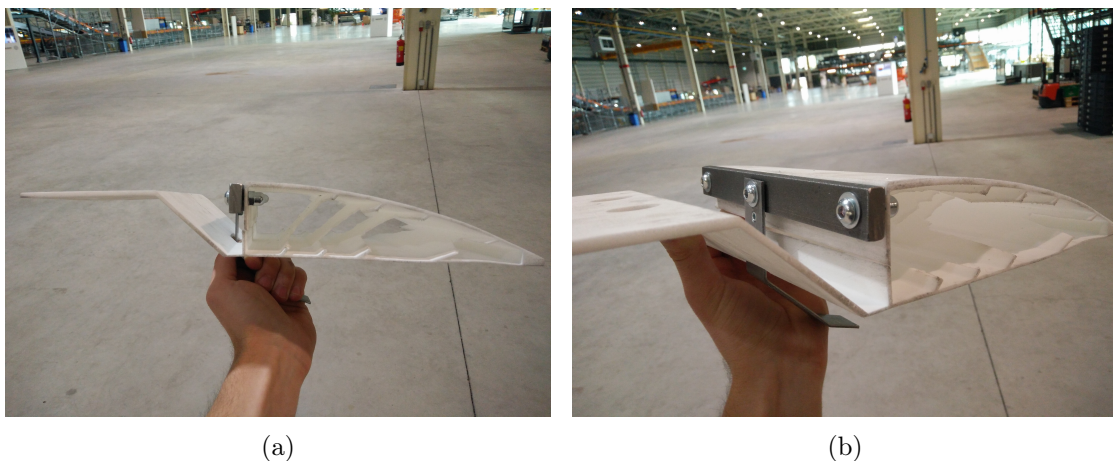

Figure 6.5: Prototype alpha after physical changes.

To manufacture the bracket components, several machines and tools were used: from cutting and drilling machines to metal sheet bending and sander machines.

Results

The test was carried off at the Advanced Design Centre of the company. The used machine to test the prototype was the Posisorter – this sorter is used specifically for testing. Since the SPO and SCO share most of the components, the Posisorter can be adapted to a SCO by removing divert shoes and assembling sort beams. Hence, the prototype was mounted on the sorter and then tested.

The modified prototype was able to bend and the bracket was capable of pushing the top surface of the beam forward (see figure 6.6).



(a) Angle between carriers: 25°

(b) Angle between carriers: 37.5°

Figure 6.6: Prototype alpha test results.

Analysis

It is noticeable that the sort beam only bends in the section (close to the shoe), while the rest stays flat (see additional figure A6a in annex).

The cut on the back flange helped the top surface going forward. However, part of that flange was interfering with the bending event, since the bracket was touching it when the beam was fully bended, preventing the bracket of progressing.

Additionally, the cut in the back of the prototype also showed an unknown behaviour: the top surface of the beam was not only pushed forward but also upward.

Measurements

The goal of the bended sort beam is to keep the entire model inside a circumference with a radius of 330 mm in the drive section of the system with the centre of the gear shaft as the referential. The limit of that circumference is the top surface of the sort beam that sits on top of the divert shoe. Because it is difficult to measure that radius on the actual sorter, the height between the surface previously mentioned and the carrier that it sits on was measured – 48 mm. That measurement served as threshold for the rest

of the measurements – the distance between the top surface of the sort beam and the corresponding carrier bellow should be less than the threshold.

Another restriction that was created was the distance between the bottom surface of the sort beam and the carrier bellow itself: this distance (5 mm) should stay the same all the time – if this is achieved, it means that the sort beam stayed on top of the carrier during the bending event. Both thresholds were measure with the sort beam in its neutral/flat position while the others measurements were done with the bended prototype.

The measured features (see figure 6.7) were:

- distance between the tip of the sort beam (bottom and top surfaces) and carrier bellow;
- distance between the middle section of the sort beam (bottom and top surfaces) and carrier bellow;
- height of the cut flange;
- length of the curvature/section that bends.

The measurements are present in table 6.1.

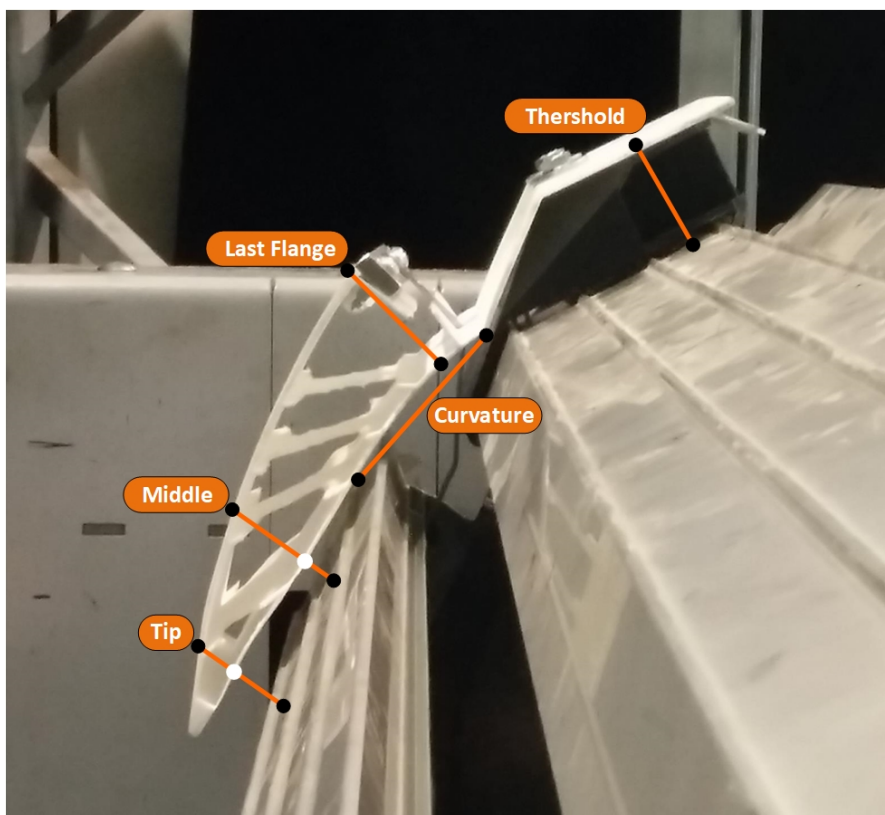

Figure 6.7: Prototype measurements.

Table 6.1: Prototype alpha measurements.

Section	Top Surf. Measurement [mm]	Bottom Surf. Measurement [mm]	Length [mm]
Threshold	48	5	-
Last Flange	54	-	-
Middle	47	13	-
Tip	42	17	-
Curvature	-	-	80

Improvements

The overall results were positive – the only part of the sort beam that did not stay inside the 330 mm circumference was the cut flange. Yet, the results can be improved.

All the flanges inside the sort beam did their job properly – they pushed the bottom surface of the sort beam downwards. However, they can be redesigned in order to promote more displacement.

The cut flange ended up being an important factor in the bending event. However, it interfered with the bracket progression. That section can be redesigned in a way that it will not be attached to the bottom surface of the beam.

Not only the flanges need to be redesigned but also the frontal section of the sort beam – the only part that needs to bend is approximately 80 mm from the divert shoe onwards. The rest of the sort beam does not need to bend.

The height of the tip of the sort beam can be increased since it raised some concerns about the sorting event – in a case of a parcel being on the tip of the beam, it might roll over it. Changing this feature can also increase the robustness of the sort beam.

Even though the bracket was capable of pushing the prototype forward and upward, it can be redesigned since the entire bending event is caused by itself. The tip of the sort beam was already close to the corresponding carrier, yet the small gap (17 mm) can be closed.

Finally, the thickness difference of the model did not make any difference because it is minimal. Hence, its thickness can be the same throughout the entire model.

6.1.3 Prototype Beta Development

Based on the results of the test of the first prototype, more ideas were generated. In order to speed up the process of simulating new designs, a new concept was created with 4 different designs in it, i.e. the sort beam was divided in 4 parts in which each part had a different design (see figure 6.8).

The improvements applied to the new concept were:

- increased size of the bracket hole (in order to have more space for the bracket to move);
- applied fillet on the edge close to the bracket hole to release stress in the flexible section of the sort beam [21] – no sharp corners;
- removed material on the last flange (because it was blocking the bracket);

- increased height of the tip of the beam (to prevent parcels of rolling over it);
- same wall thickness throughout the model;
- additional ribs on the free (cut) flange to increase the robustness when the sort beam is being pushed by the bracket.

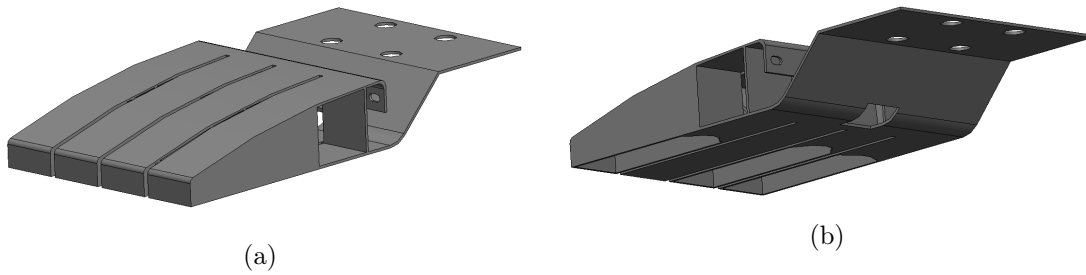

Figure 6.8: CAD overview of the new study model.

The 4 different designs have the following differentiating features (see figure 6.9):

1. vertical double flange design with closed side surfaces and opened bottom surface;
2. same design as prototype alpha but with the improvements previously mentioned;
3. wavy and tilted double flange design with covered side surfaces and opened bottom surface;
4. vertical and tilted triple flange design with covered side surfaces and opened bottom surface.

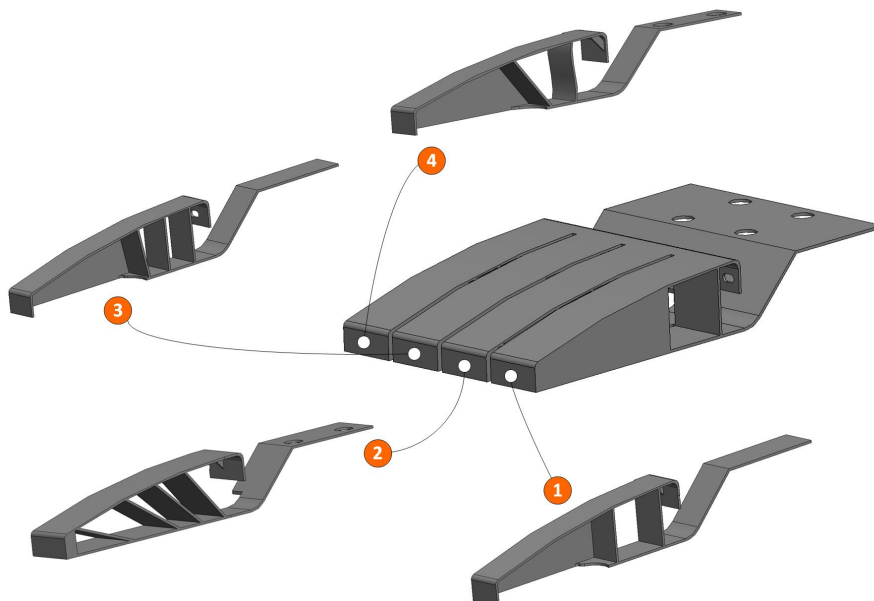

Figure 6.9: CAD overview of the new study model interior.

The reason the front part of the sort beam lost the flanges relates to the no need of flexibility. The flanges inside of the sort beam are responsible for pushing the bottom surface downward [14]. If they do not exist in a specific section of the sort beam, that section will not be pushed down. From the prototype alpha results, it was concluded that the sort beam only needs to bend in a certain section and that section is the one that has flanges on the concept previously shown.

After designing the concept, FEM simulations were carried off. It is notable that, even though the sections are divided, they are connected by the last flange. Hence, the displacement of every design is expected to be very similar to each other while the stress distribution should be different.

The simulation was tuned in order to have a behaviour as close to reality as possible: the force is applied on the last flange is pushing the sort beam forward and upward. The fixed features and mesh type were the same (see figure 6.10).

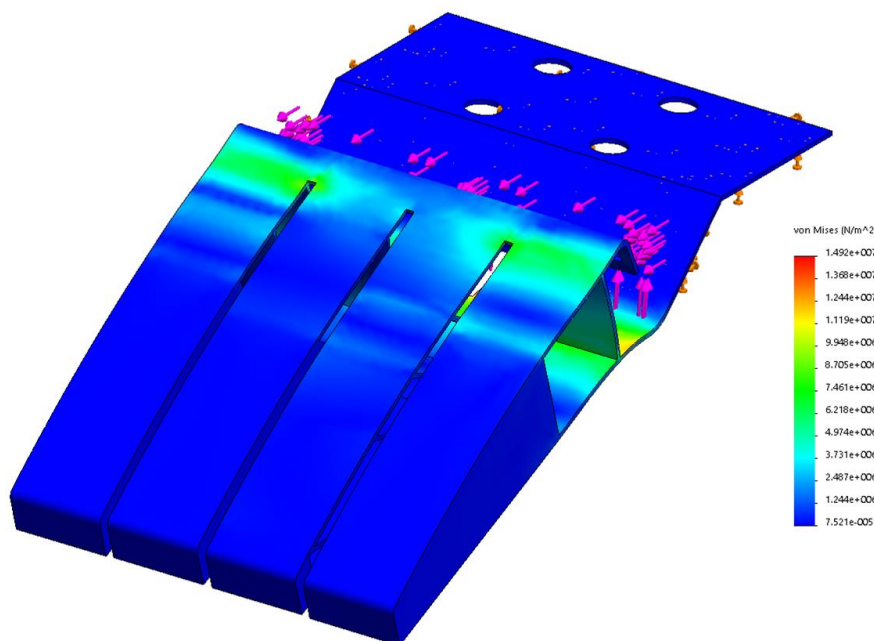

Figure 6.10: FEM simulation stress results for the new study model.

A macro analysis to the results shows that with the improvements, the model can bend the section closer to the divert shoe while keeping the frontal part straight and, most important, with no stresses.

On a closer look, the feature that is most noticeable is the stresses created by the vertical flanges of the first and fourth designs. On both bottom and top surfaces, the stresses are high when compared with the other designs. Both vertical flanges were also closer to the shoe, what means that their position is also not ideal (see additional figure A7 in annex).

On the second and third designs, the stresses are lower and the displacement similar but slightly larger than the first and fourth designs (≈ 1 mm). However, on a life cycle assessment perspective [2], it is preferred to have the stresses divided through the sort beam (what is possible to see on the top surface of the second design) rather than having

large stress located in one part only (what is evident on the top surface of the first and forth designs) [19]. Therefore, the second and third designs were combined and developed together.

Prototype Beta Iterations

One very important feature of the second design is the flanges inside the model. They can push the bottom surface down, however that action may be improved. If their orientation changes to the opposite, i.e. adding approximately 90° clockwise, it would have the same direction as the momentum created by the applied force and the length of the section that should bend is also larger. This adjustment should increase the tip's displacement considerably (see figure 6.11). Therefore, both orientations were tested and analysed.

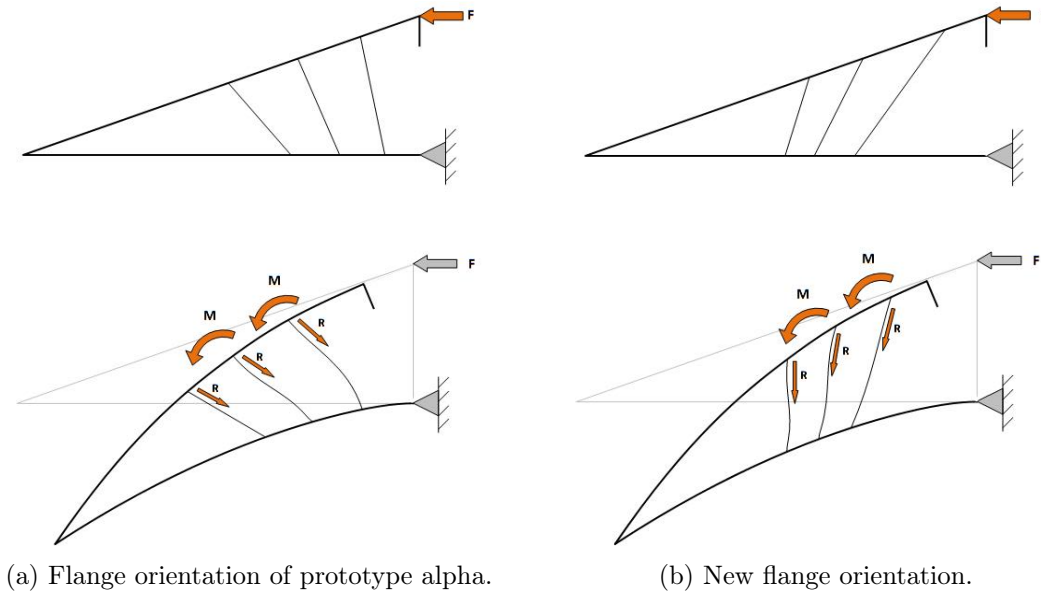

Figure 6.11: Flange orientation modification.

The created models have a triple flange design. The first one has the same flange orientation as prototype alpha (see figure 6.12a) and the second one has a different flange orientation (see figure 6.12b). On both designs, the model has no flanges on the frontal section.

Once again, the applied force was tuned to perfect the FEM simulation.

The FEM simulations show the difference between the orientation of the flanges. The model with a new flange orientation increased approximately 85% the displacement – 103 mm on the model on the left to 192 mm on the model on the right (see figure 6.13). Hence, the chosen design to be developed was the one in figure 6.12b.

Regarding a requirement that states that the sort beam must not interfere with parcels, i.e. its side surfaces should have no openings, the side surfaces were partially closed. Furthermore, an opening was created in the bottom surface of the beam – there are no flanges in that section (see additional figure A9 in annex).

The new model was then meticulously analysed in order to discover sections with large stresses. In the junction between the side and bottom surfaces of the model, a

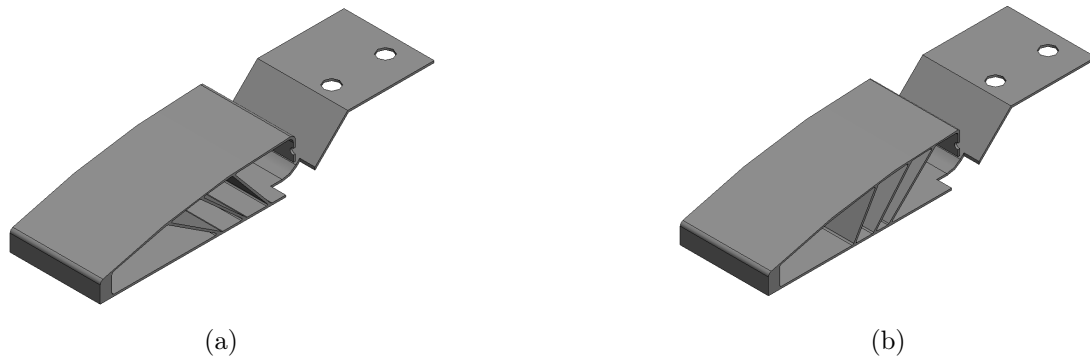

Figure 6.12: CAD overview of the models with different flanges orientation.

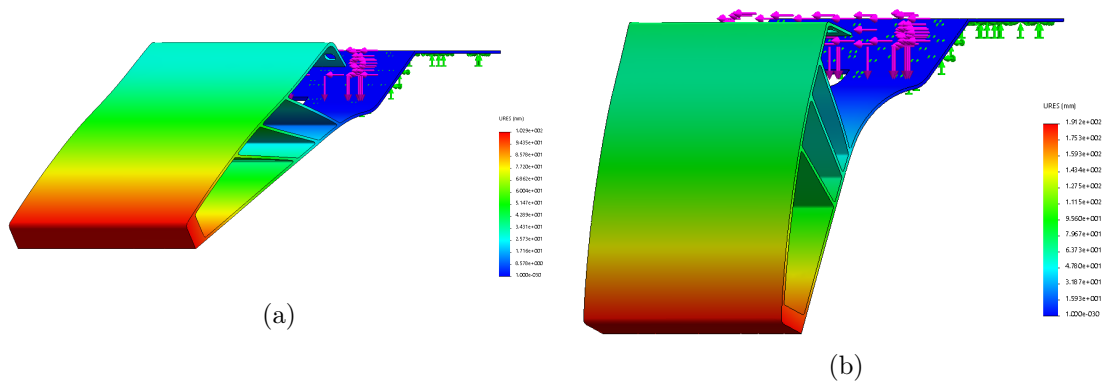

Figure 6.13: FEM simulation displacement results for different flanges orientation.

vulnerable point was discovered (see figure 6.14). In a life-cycle perspective, these stresses would decrease the robustness of the sort beam in that specific area especially due to the constant impact of sorting parcels [15]. Another section that was discovered with relatively large stresses was the top surface of the model, more specifically on top of the last flange.

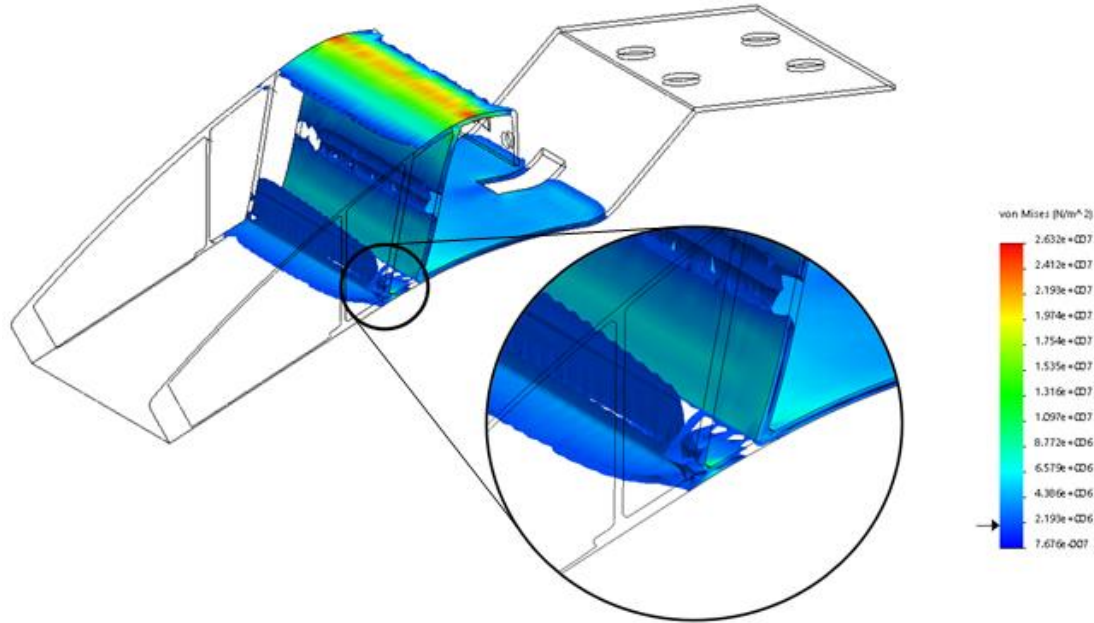

Figure 6.14: High stresses between side cover and bottom surface.

To solve both problems, the design was slightly changed. The side surface of the model was redesigned and some ribs were added.

The point with large stresses does not exist with the redesigned side surface. Furthermore, the stresses on the top surface are equally divided in a better way – in figure 6.15 the red area is narrower. In figure 6.14 the change from red to green is abrupt (almost no yellow) while in the improved concept, the yellow area is more noticeable – the stresses are divided with a progressive way instead of having large stresses in only one area.

Bracket Iterations

Not only was the sort beam model was improved but also the bracket. Since the results from the previous test were good but not ideal, the bracket was redesigned in order to increase the displacement of the tip of the sort beam.

Bearing in mind that the main goal is to have the bottom surface of the sort beam as close as possible to the carrier (if possible, touching it) and that the entire bending action happens because of the bracket, it is very important to have the right design to achieve the intended results.

Since it is not possible to see the bracket movement on the Posisorter during the test (the sorter is fully closed), a simple drive section of the SCO was built in order to have a better grasp of the bracket behaviour (see figure 6.16).

The assembled kit to test the bracket allows to see its movement at all times, instead of seeing only its position before and after the bending event (like what happens on the

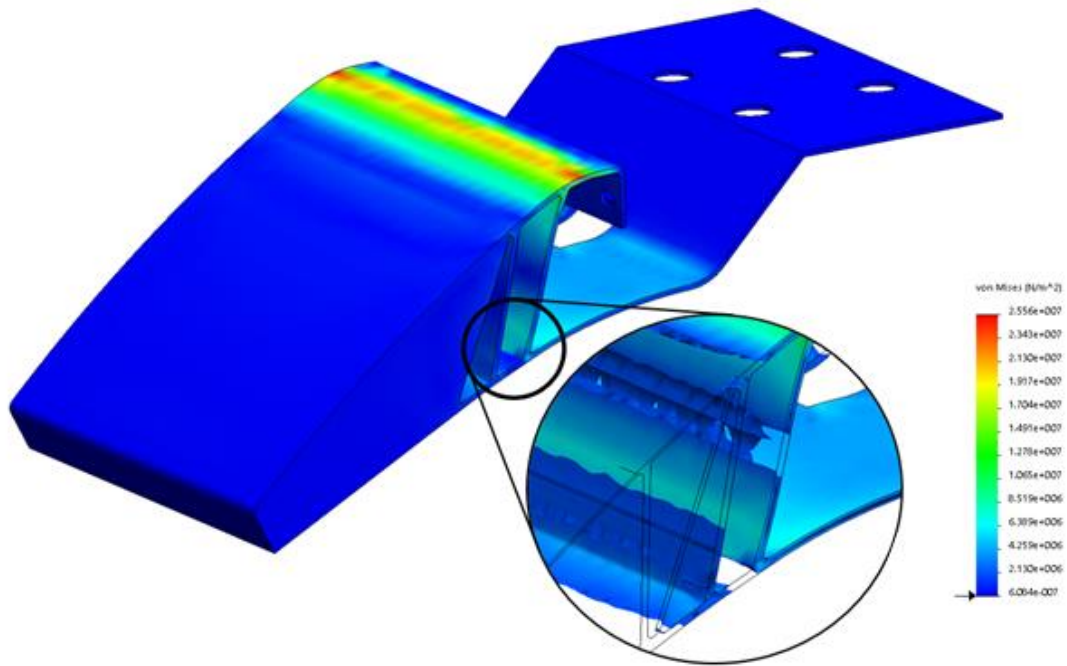

Figure 6.15: Stresses between side cover and bottom surface after redesign.



Figure 6.16: Bracket testing set.

Posisorter). Hence, it is possible to analyse the bracket behaviour and then improve the mechanism with design changes.

Based on the test results of prototype alpha, 3 brackets were manufactured and then tested. It is possible to see the design evolution that the bracket went through from the left to the right bracket in figure 6.17.

In order to increase the displacement of the sort beam, the tip of the bracket needed to move more forward. The solution for this problem was to have the bracket closer to the carrier so it would be pushed down earlier and, therefore, actuating on the sort beam also earlier.

The brackets had the following results:

1. the bracket on the left in figure 6.17 slipped off the carrier when it was close to the 37.5° milestone;
2. the middle bracket in figure 6.17 started to bend earlier than the previous one but also slipped off the carrier close to the maximum angle between carriers;
3. the bracket on the right in figure 6.17 started to bend early as well and it pushed the sort beam further than any other bracket tested before. Yet, in the end, it also slipped off the carrier.



Figure 6.17: Tested brackets.

Based on the results of the 3 tested brackets, it was concluded that the bracket needed to occupy more space between the carrier and the shoe to be pushed down earlier and then be stuck on the divert shoe – this way the bracket should not slip off the carrier. The length of the bracket was also another important aspect because it has to hold its position when the carrier hits 37.5° what corresponds to approximately 40 mm between carriers. Accordingly, another bracket was manufactured and tested (see figure 6.18).

Due to the fact that the new bracket was ready before prototype beta, it was tested with prototype alpha. Therefore, another flange of prototype alpha was cut aiming to have a more freely bracket like what is intended on prototype beta. Hence, the bracket was tested on the testing set.

The new bracket had the best results so far. A feature that is notorious is the sort beam touching the back part of the carrier (see figure A8 in annex). This means that the sort beam needs to bend over the carrier, i.e. adapt its shape to the carrier.

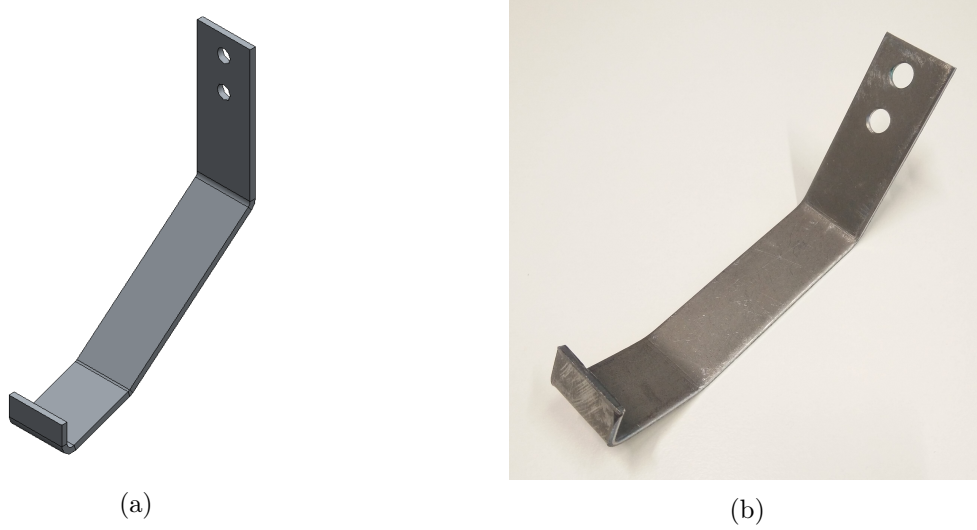

Figure 6.18: Bracket iteration.

However, the bracket touched the carrier all the time, from the beam's neutral position to the fully bended position. This interaction was causing wear/friction either on the bracket and carrier along with the sharp sound of sliding metal on the carrier. Thus, the option was to cut the tip of the bracket that was touching the carrier and replace it for a plastic block which would cause almost no wear/friction and possibly no sound (see figure 6.19).

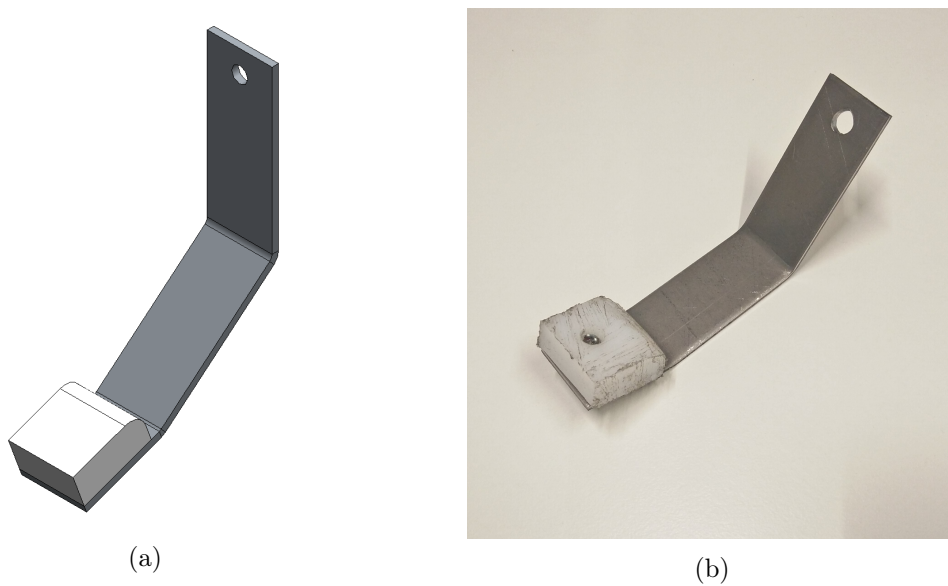

Figure 6.19: Bracket with plastic block.

6.2 Prototype Beta

The second prototype was also ordered to an external company. The wanted material was LDPE but it was not possible to produce the model with it. However, it was advised polypropylene (PP) that has similar mechanical properties to LDPE [5] [12]. The technology used to produce the prototype was again SLS. The model is presented in figure 6.20.

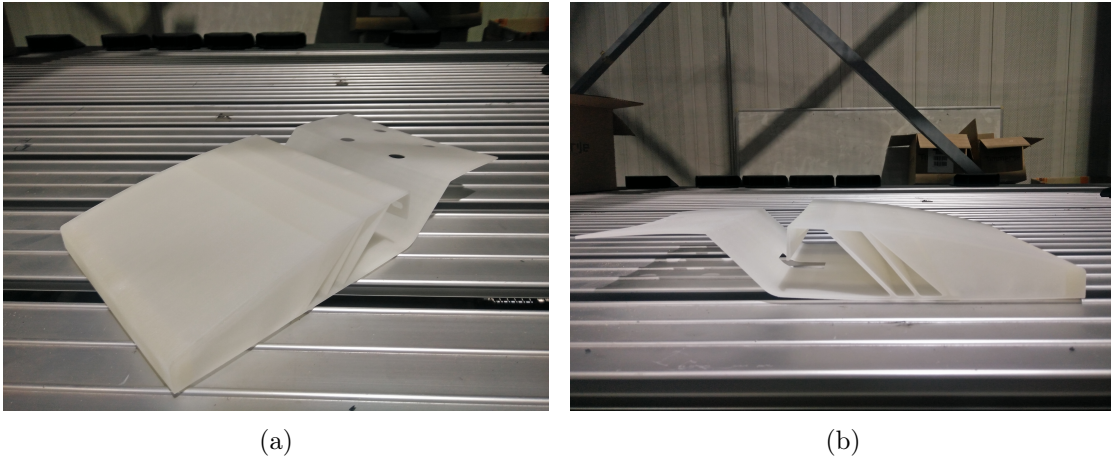

Figure 6.20: Prototype beta.

The chosen material was flexible enough to test the prototype without any physical modification.

6.2.1 Physical Test

The prototype was firstly tested on the testing set because it was faster than testing it on the Posisorter – no need to adapt and change parts on the testing set. The assembled prototype is shown in figure 6.21a.

The sort beam was capable of bending and the improved bracket could also push the top surface of the prototype forward in a way that the bottom surface of the prototype was touching the carrier (see figure 6.21b).

The new sort beam and bracket designs solved the issues that prototype alpha had. The section that should bend, bended easily. The front section, the part that should stay plain, held straight and the hole for the bracket also let the bracket move freely during the bending event.

It is important to mention that the results were slightly affected due to the fact that the testing set was on a horizontal position.

Meanwhile, the bracket was improved in order to provide a bending event more stable and linear, i.e. when the sort beam is bending it should not have small jumps, it should be on top of the carrier all time with no interferences/vibrations.

Bracket Redesign

The bracket was then redesigned, more specifically the plastic block (see figure 6.22), having in mind the following features:

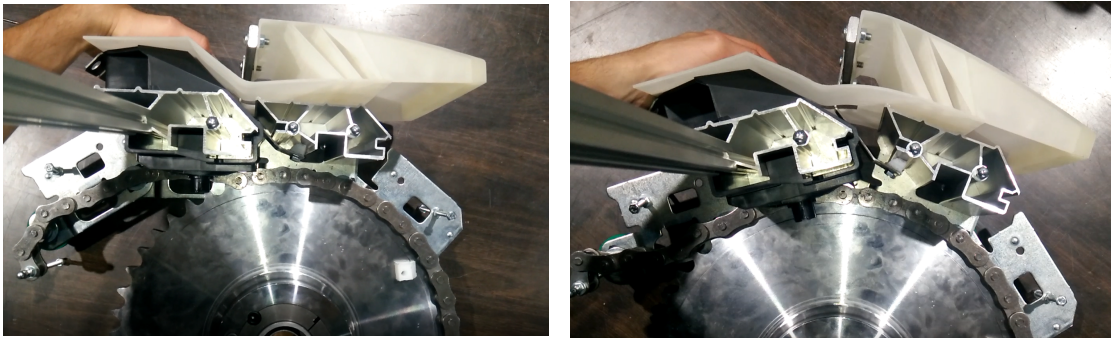

(a) Flat position.

(b) Bended position.

Figure 6.21: Prototype beta on testing set.

- length of the plastic block – to make sure it would not be on the edge of the carrier when the carrier hits $37,5^\circ$;
- width of the plastic block – to distribute the stresses on the surface of the block;
- angle of the plastic block – to touch 2 edges of the carrier instead of 1.



(a)

(b)

Figure 6.22: Redesigned plastic block.

Testing Set with New Bracket

Firstly, the new bracket was tested on the testing set to predict its behaviour.

The bracket touched the shoe and the carrier the entire time. It started touching 2 edges of the carrier. Then, when the carrier went down, the bracket slid and it touched only one edge (see figure A10b). On the reverse movement, i.e. coming back to its initial position, the bracket touched again the 2 edges of the corresponding carrier (see stages in figure A10 in annex).

During the returning movement (from bended to neutral shape), another feature was noticed: the opening in the bottom of the sort beam (see figure 6.23a) was interfering with the carrier. Even though the opening in the bottom surface of the sort beam has

a fillet, it did not prevent the beam of interfering with a rib of the carrier (see figure 6.23b). Yet, the sort beam was able to surpass the rib of the carrier with a small bounce.

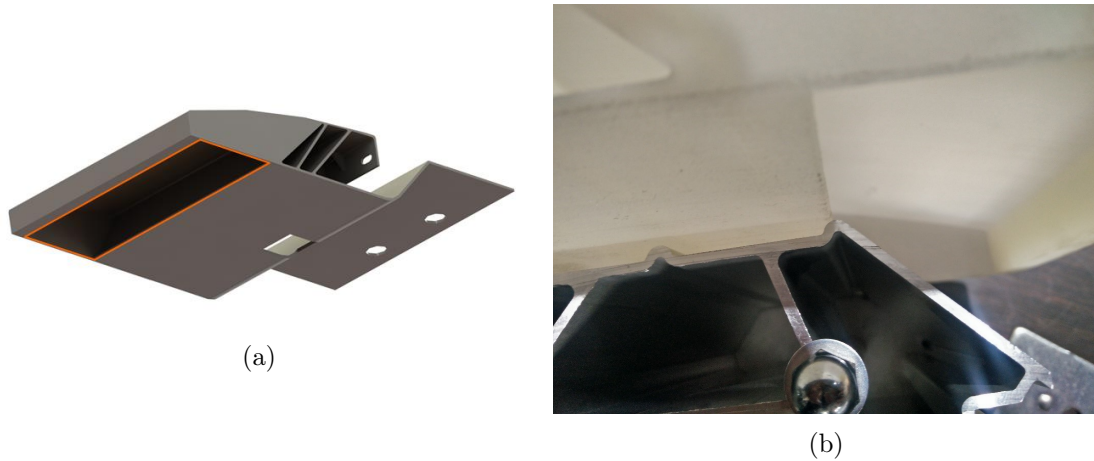

Figure 6.23: Prototype beta interference with carrier.

6.2.2 Posisorter Test

The assembled prototype on the Posisorter is shown in figure 6.24.



Figure 6.24: Side and top views of prototype beta in Posisorter.

Manual Test

Firstly, the sorter was pulled manually instead of automatically.

During this test, the prototype bended and the bracket worked well (see figure 6.25).

An important feature that was not investigated until this moment was the sort beam and bracket behaviours when the prototype is upside down, under the gear in the drive section. In order to have the sort beam on top of the carrier, the bracket must hold it in this position as well. Therefore, to analyse their behaviours, the sorter was moved until

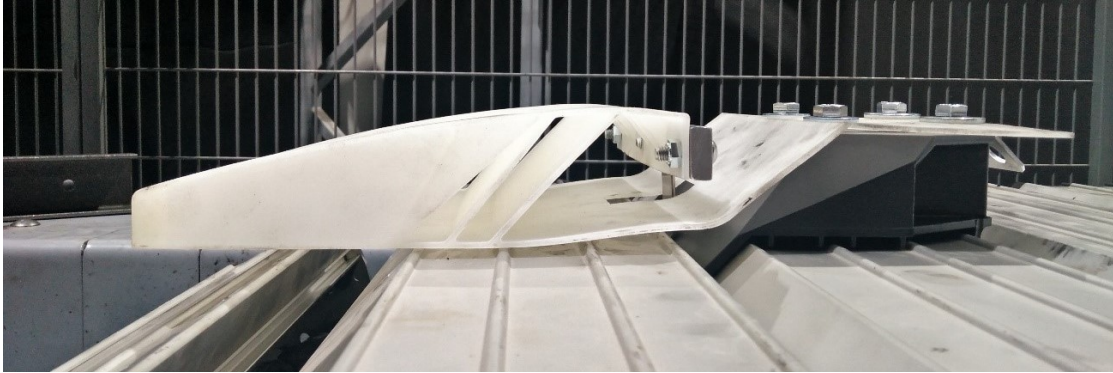

(a)



(b)

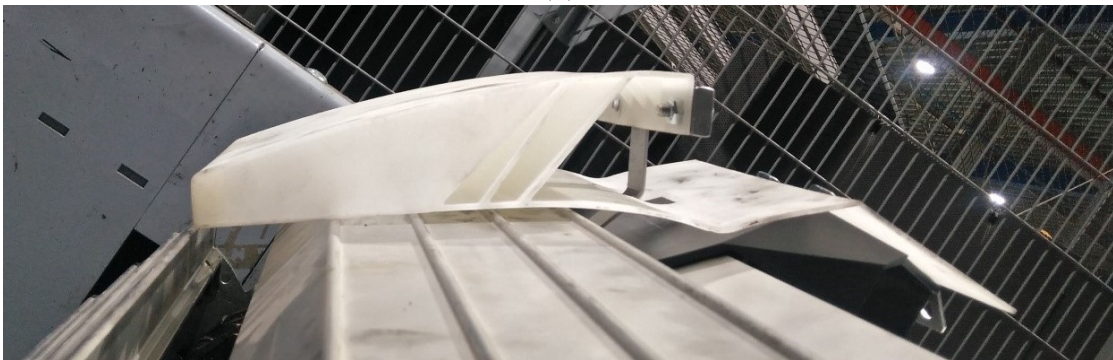

(c)

Figure 6.25: Prototype beta manual test.

the prototype was under the machine. The bracket was able to firmly hold the sort beam (see figure 6.26).



Figure 6.26: Upside down prototype beta in Posisorter.

However, during the transition from bended to neutral, the sort beam bounced again over the rib of the carrier.

Automatic Test

Due to the positive results, the automatic test was carried off.

The behaviour of the sort beam was the same as in the manual test: it bended and the bracket held its position (see figure 6.27) but the small bounce over a rib of a carrier was louder than before due to the actuating forces.

Results Analysis

Before the sort beam reached the drive section, the bracket was already applying some pressure on the sort beam due to the fact that the bracket was touching the carrier. This event made the section where the bracket is attached to go slightly down and, in addition, the sort beam reacted bending the designed flexible section – the bottom surface. Also, the tip of the beam was already touching the corresponding carrier (see figure A11 in annex).

When the sort beam returned to its neutral shape bellow the sorter, the opening in the bottom (see figure 6.23a) was interfering with the carrier. Furthermore, during the last test, the bounce caused some vibrations. This may be a problem when the sorter is running at maximum speed (1,7 m/s) because the forces involved will be greater, possibly damaging the sort beam or other components.

Since this test was done with the divert shoe pushed completely to the left of the sorter, it exposed that the sort beam was too close to the side guarding of the sorter, i.e. it was too wide.

In the end of the test, the sort beam and the bracket were undamaged. However, the bracket was slightly loose.

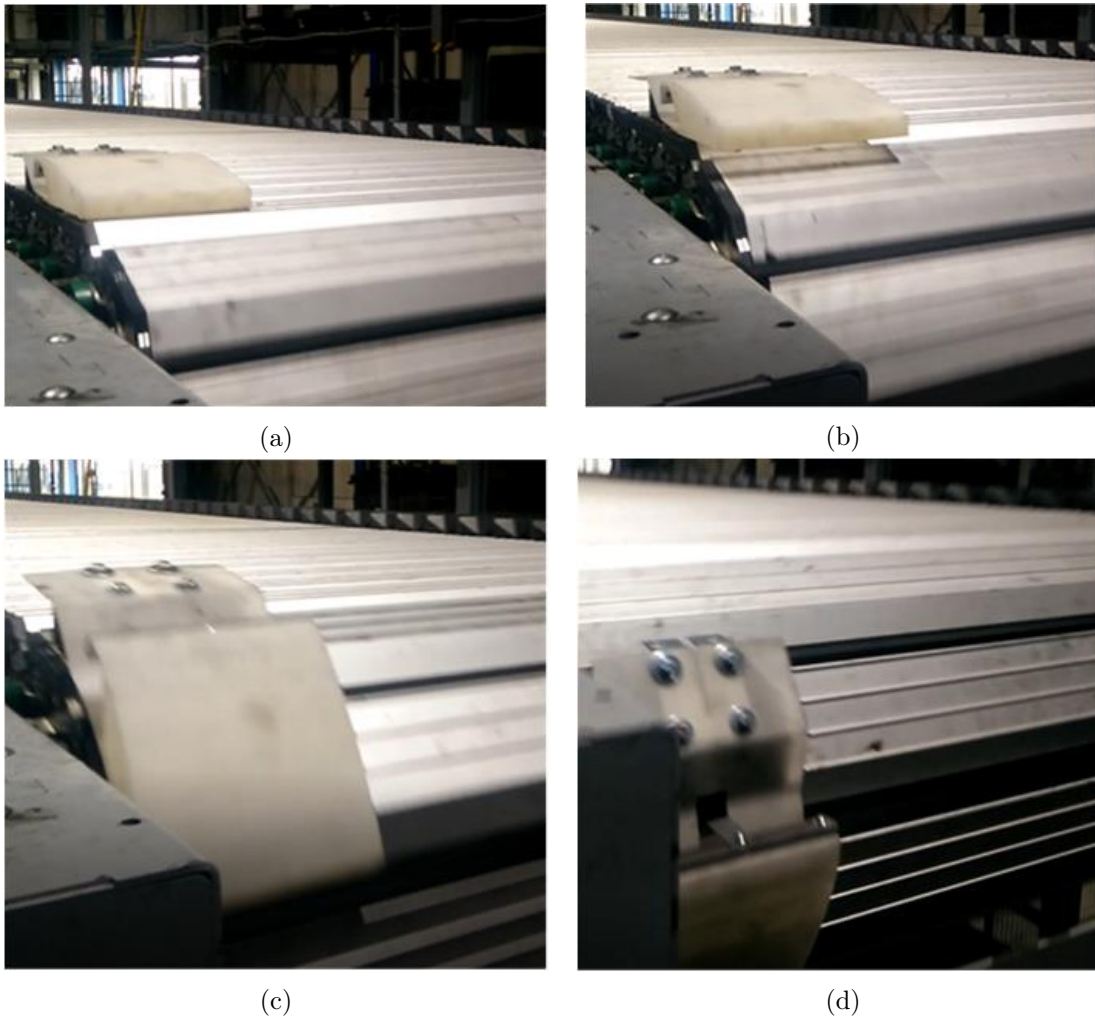

Figure 6.27: Prototype beta automatic test.

Measurements

The goal of the bending event is still the same: keeping the bottom surface on top of the carrier (5 mm) and keep it to a maximum height of 48 mm measured perpendicular to the carriers.

The results from this test were considerably better than the first one: the bracket not only pushed the sort beam more forward but also more upward. Plus, the bottom surface of the sort beam stayed on top of the corresponding carrier the entire test.

The new measurements are present in table 6.2.

Table 6.2: Prototype beta measurements.

Section	Top Surf. Measurement [mm]	Bottom Surf. Measurement [mm]	Length [mm]
Threshold	48	5	-
Last Flange	59	5	-
Middle	41	5	-
Tip	20	5	-
Curvature	-	-	80

The front section of the sort beam that was designed to stay flat during the bending event was proved to be right. The mentioned section did not bend – it stayed flat while the flexible designed section was easily bended.

The results show that it is convenient for the last flange to surpass the 48 mm threshold – it helped keeping the sort beam on top of the carrier. Therefore, in the future, the 48 mm threshold will not be applicable for the last flange measurement.

On the bracket side, it started pushing the sort beam before it should. Due to this pressure, the divert shoe with the prototype requires more than 6 kg of force to start sliding on the carrier while the current sort beam needs approximately 3 kg of force.

Nonetheless, the main goal of the sort beam, touching the carrier all the time, was achieved.

Improvements

The hole in the bottom of the sort beam has to be either closed or redesigned since one of its edges was interfering with the carrier, what can cause severe damage to the sort beam or other components when the system is running at full speed.

The pressure generated by the bracket on the sort beam creates a section with high stresses – the section of the sort beam which is attached to the bracket. Hence, this part should be redesigned to act like a hinge, which will release some of the stresses provoked by the bracket when it actuates on the sort beam.

Last but not least, the bracket should be redesigned in order to touch the carrier only during the bending event, but, at the same time, it must be able to fully bend the sort beam when the angle between carriers is 37.5° .

Part V

Prototype Analysis

Chapter 7

Bracket Behaviour

Simulating the bracket movement in Solidworks is problematic since the only simulation available was the static one and the bracket movement requires motion analysis with flexible bodies.

Consequently, the solution to this problem was MATLAB. A 2D simple drive section of the SCO was coded in order to simulate the carrier movement and predict the bracket behaviour – multi-body mathematical model [28].

7.1 MATLAB Model

The model simulates a real scaled drive section of the SCO. It shows the movement of the carrier in the drive section of the SCO until it hits 37.5° . The initial modelled parts of the system were the divert shoe in black, the sprocket (SCO component) in yellow and the carrier in blue (see figure 7.1).

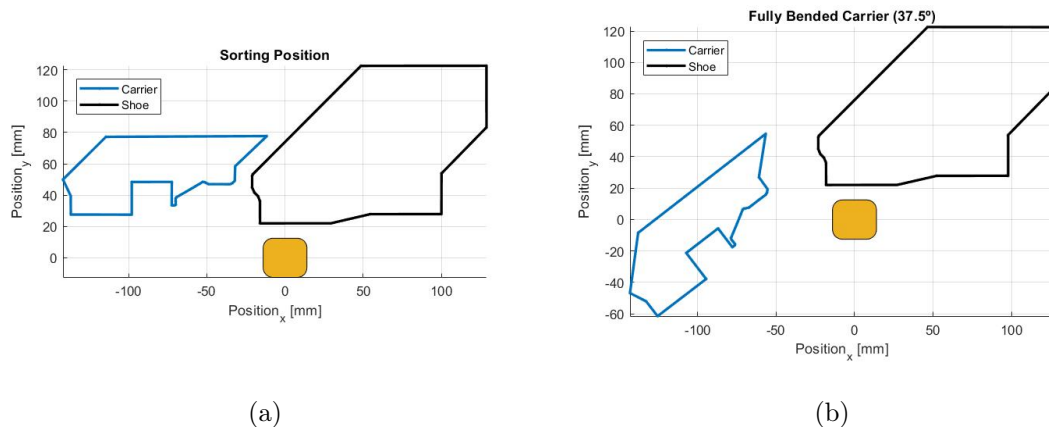

Figure 7.1: Carrier movement representation.

The movement of the carrier is not straightforward. When the carrier reaches the drive section of the SCO, i.e. when it is engaged in the gear, it moves slightly back, decreasing the distance between carriers. After this discrete movement, it starts to bend.

Additionally, the carrier does not rotate around the gear in the drive section but around the sprocket on the carrier with the divert shoe.

7.1.1 Inputs

In behalf of the prototype beta tests, important data was generated. Since the prototype was fully bended, the displacement of the tip of the bracket that is attached to the sort beam is known. Therefore, the point that the bracket needs to be in order to push the sort beam forward and upwards enough to totally bend the sort beam, can be measured.

Because the Posisorter and testing set tests had the same results, the displacement of the tip of the bracket was measured on the testing set. The distance between carriers was manually defined in order to have the same distance as in the SCO. Furthermore, the sort beam was bound to the carrier in front of the divert shoe in order to avoid any discrepancies. Afterwards, the final position of the tip of the bracket was measured.

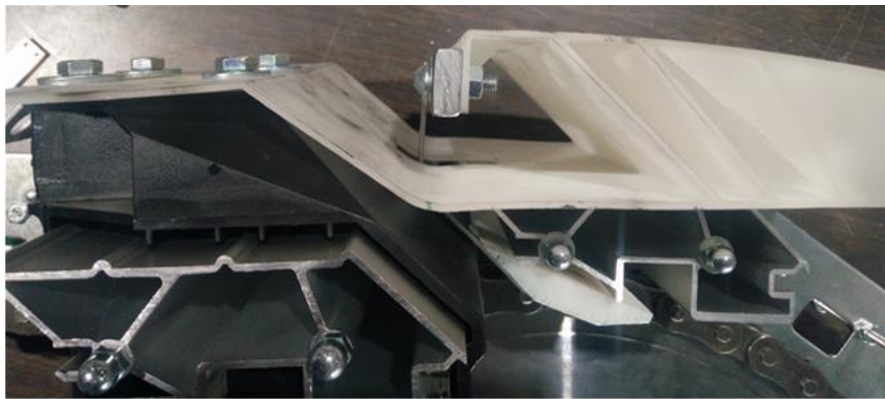

(a) Initial position.



(b) Final position.

Figure 7.2: Bracket tip displacement.

Table 7.1: Bracket tip displacement measurement.

Measurements from Testing Set			
x disp. [mm]	y disp. [mm]	Total disp. [mm]	Angle [°]
38.1	7.8	38.9	11.6

Once the bracket displacement was measured, a goal was set: design a bracket that is not touching the carrier during the sorting event and that is capable of fully bending

the sort beam.

Nonetheless, new and adjusted requirements emerged:

1. the bracket cannot go lower than the lowest level of the divert shoe due to the presence of other components (see figure A12 in annex);
2. during the sorting event, the bracket must not touch the carrier. It can touch the divert shoe if that does not interfere with the sorting and if does not cause wear/friction on both components (adjusted requirement);
3. the bracket cannot be wider than 20 mm.

7.1.2 Bracket Design

The bracket was designed along with the concept of reverse engineering. The first concern was to fit the bracket on the available space and then its final position was manually predicted in MATLAB. If the bracket was able to fit on the available space without touching the carrier and shoe and, at the same time, if it could bend the sort beam completely, other positions of the bracket, i.e. carrier angles between 0° and 37.5° , were also predicted. Otherwise, a new design was created [25].

In order to avoid the bracket being loose in the end of the bending event, the bracket support was changed – material was removed in a way that the bracket fits impeccably and cannot rotate around the screw (see figure 7.3).

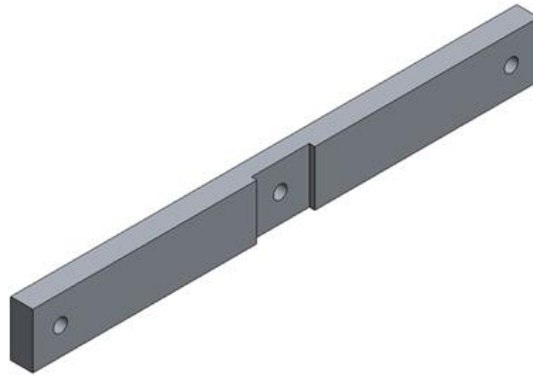

Figure 7.3: CAD overview of adapted bracket support.

Subsequently, the bracket went through the redesigning process (see figure 7.4).

The main differentiate feature of the new brackets is the plastic block design. Its design follows the shape of the region of the carrier that the bracket will touch during the bending event.

The metal part was slightly changed while the plastic block was completely redesigned.

The first new design is present on the left in figure 7.4. The bracket fitted on the available space but when the angle between carriers was 37.5° , the bracket was too close to the edge of the carrier.

Consequently, the plastic block was redesigned – its length increased. However, due to that addition of material on the tip of the plastic block, that section was weak and

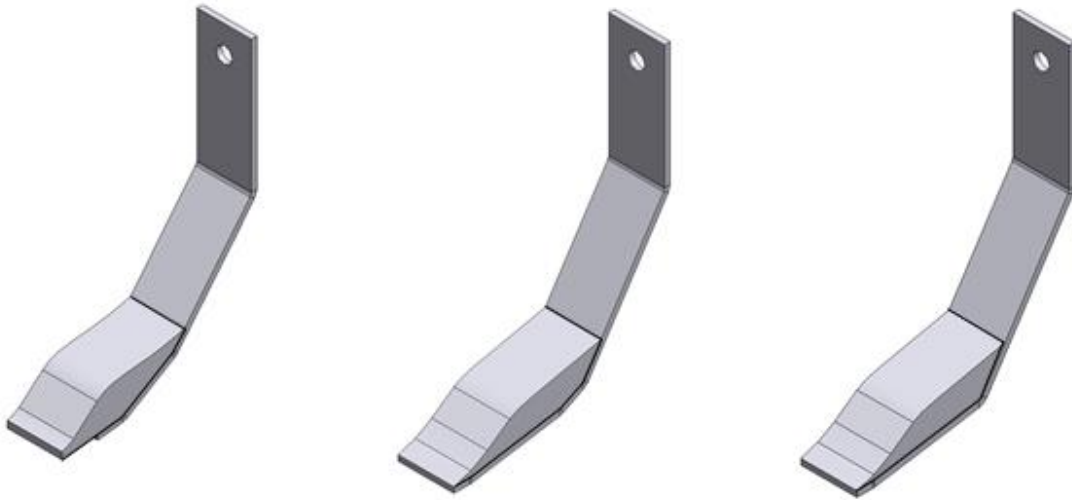

Figure 7.4: CAD overview of the MATLAB iterated brackets.

could break during the bending event since the actuating forces to bend the prototype are applied on the bracket. Accordingly, the metal part of the bracket was extended to cover the plastic block completely (see middle bracket in figure 7.4). This bracket was able to push the sort beam beyond the require point but it could be marginally improved.

In a production point of view, the metal part is bended into 5 segments. This means that 4 bending operations are needed to produce this component. Therefore, the last design was created – instead of bending the metal part into 5 segments, it could now be bended into 4, having 3 bending operations instead of 4. Additionally, the segment that is touching the divert shoe increased its length (see figure A13 in annex). Since the bracket slides upwards when it touches the divert shoe, this modification brings an advantage of having a few millimetres more to slide upward.

The prediction of the bracket behaviour is shown in figure 7.5. The measured point from figure 7.2, i.e. the point that the tip of the bracket has to reach, is represented in light green.

In the sorting position the bracket is not touching either the carrier or divert shoe. Then, when the carrier is geared in the drive section, it starts to touch the bracket. When the carrier hits 37.5° , the bracket still has a considerable large section stuck on the edge of the carrier, what should ensure that the bracket will not slide off. With the usage of this bracket, the sort beam has the potential to be pushed more forward than the bracket tested with prototype beta, what means that the sort beam should be completely bended.

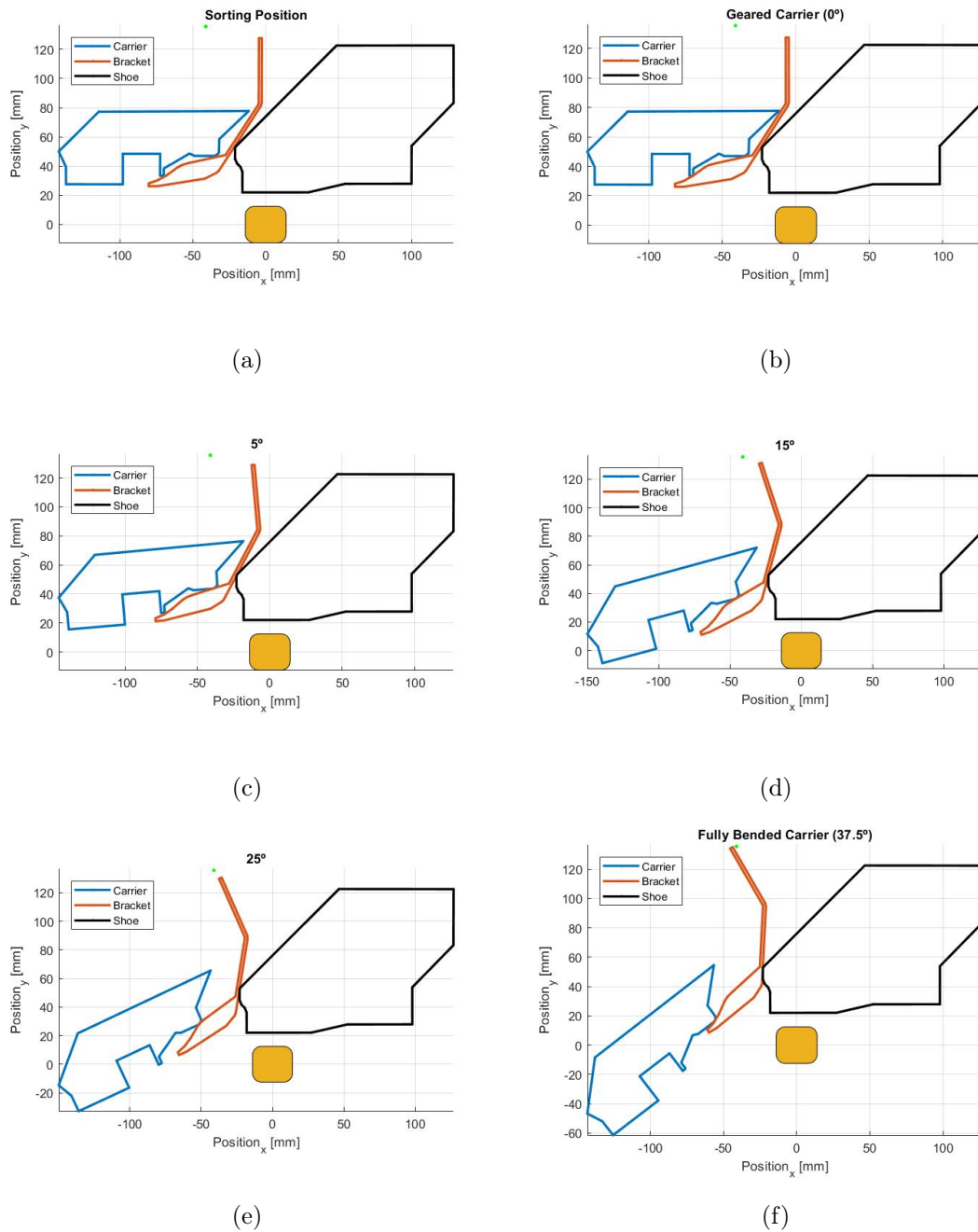

Figure 7.5: Prediction of the bracket movement.

Part VI
Future Work

Chapter 8

Sort Beam Design

8.1 Front Part

8.1.1 Sort Beam Design

The design of the section that sits in front of the divert shoe needs to change 2 features:

1. the opening in the bottom surface must be covered/redesigned in order to not interfere with the carrier when the sort beam is coming back to its neutral shape;
2. the ribs in the last flange of the sort beam should be removed in order to decrease the stress during the bending event. Adding a radius to that edge will mimic a hinge, allowing that section to bend more easily [11].

Thus, the opening in the bottom surface was redesigned in a way that it will not interfere with the rib of the carrier. Furthermore, the ribs on the sort beam were removed and the section that has the bracket attached to was also redesigned to promote a more flexible behaviour (see figure 8.1).

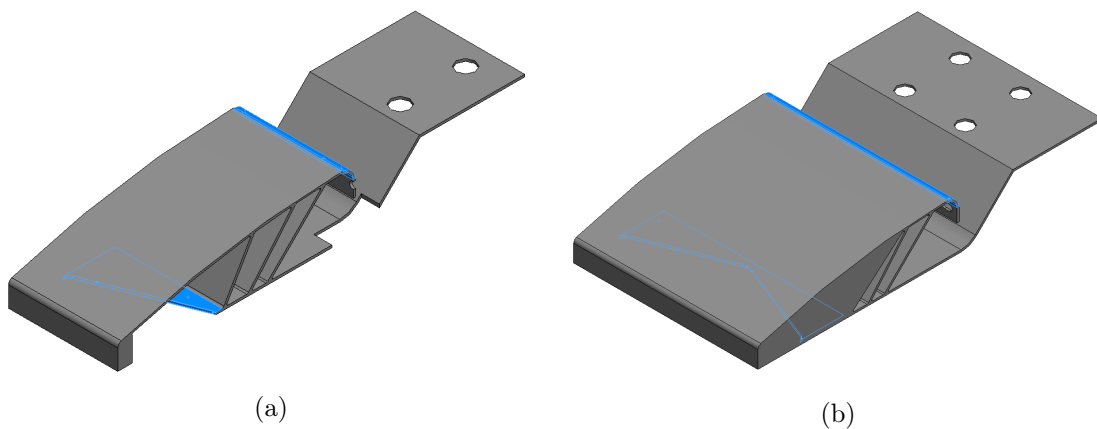

Figure 8.1: Suggested revision to prototype beta.

8.1.2 Bracket Design

A fully functional bracket was also developed. However, it should be manufactured and tested in order to validate its design.

The bracket should be made out of 3 parts:

1. metal part that is attached to the sort beam;
2. metal part that is pushed against the divert shoe;
3. plastic block that touches the carrier.

The metal part that will be attached to the sort beam can be manufactured manually on the cutting and drilling machines. However, the remaining two parts should be machined (CNC - Computer Numerical Control) to have the right design – the angles of the metal part must be accurate as well as the dimensions of the plastic block.

8.2 Back Part

The section of the sort beam that is behind the divert shoe should be based on the same design and bending principles of the front part in order to simplify as much as possible the model.

The bending mechanism of the front part can be used to bend also the back part, avoiding adding another bracket in the back part of the sort beam. Moreover, due to the carrier design, it is inconceivable adding a new bracket to the back part of the sort beam. Thus, in order to use the same bracket, the top surface of the back part of the beam cannot be pushed. Instead, the bottom surface must be pulled to bend the desired section (see figure 8.2).

Therefore, to bend the top surface when the bottom surface is being pulled, flanges must be present.

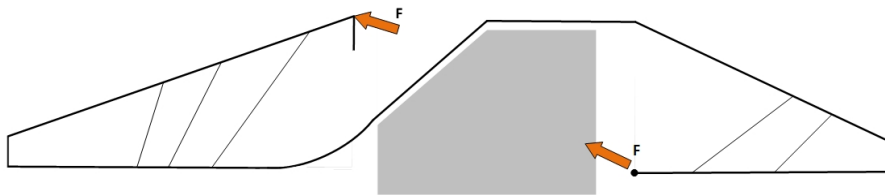

Figure 8.2: Suggested concept for complete sort beam.

8.2.1 Flanges Design

The flanges have approximately the same orientation as the flanges in the front part for the same reason: they have approximately the same direction as the applied force in order to increase the tip displacement, as it was shown in chapter 6.1.3 for the front part (see figure 8.3).

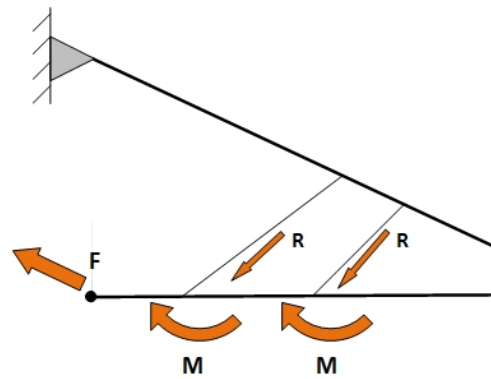

Figure 8.3: Back flanges orientation.

The number of flanges decreased when comparing to the front part because this section is shorter. Moreover, on the back part, the section that needs to bend is the top surface, opposite to what happens in the front part.

Furthermore, part of the side surfaces on the back part and shoe section were closed since they will not bend – like what happens in the front part, there is only one section that needs to be flexible. Based on the results of prototype beta, an opening was made in the bottom of the back part with a design that may not interfere with ribs of the carrier bellow.

The suggested model decreased its width from 183 mm to 165 mm because it was too close the side guarding of the sorter (see chapter 6.2.2). This adjustment will also make the model fit perfectly on top of the shoe if the thickness of its walls is 2 mm (see figure 8.4).

The opening on the shoe section is present due to the connection between the bracket and the back part of the sort beam (explanation in chapter 8.2.2).

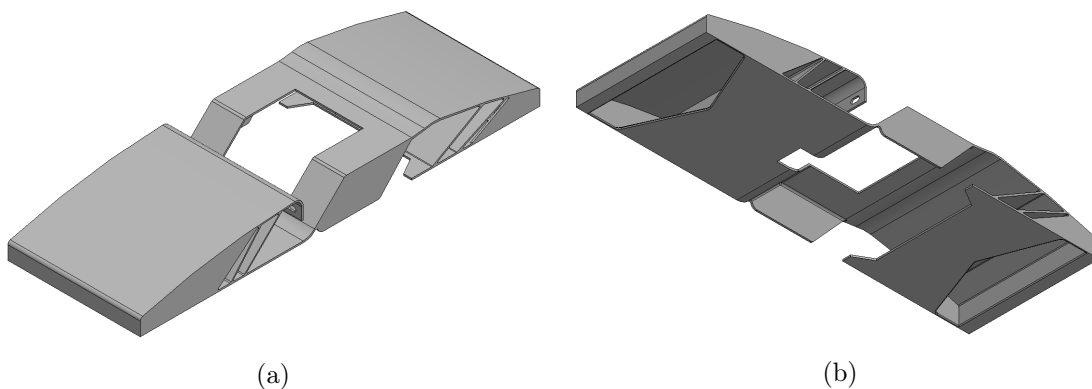

Figure 8.4: Suggested sort beam design.

8.2.2 Bracket Mechanism

In order to pull the back part of the sort beam, a connection between the tip of the bracket (or front part of the beam) and the back part of the sort beam must be present.

Additionally, since the divert shoe might change its design in the near future, the suggested design is also showed in this chapter. The central top part should be removed in order to have space for the connection (see figure 8.5).

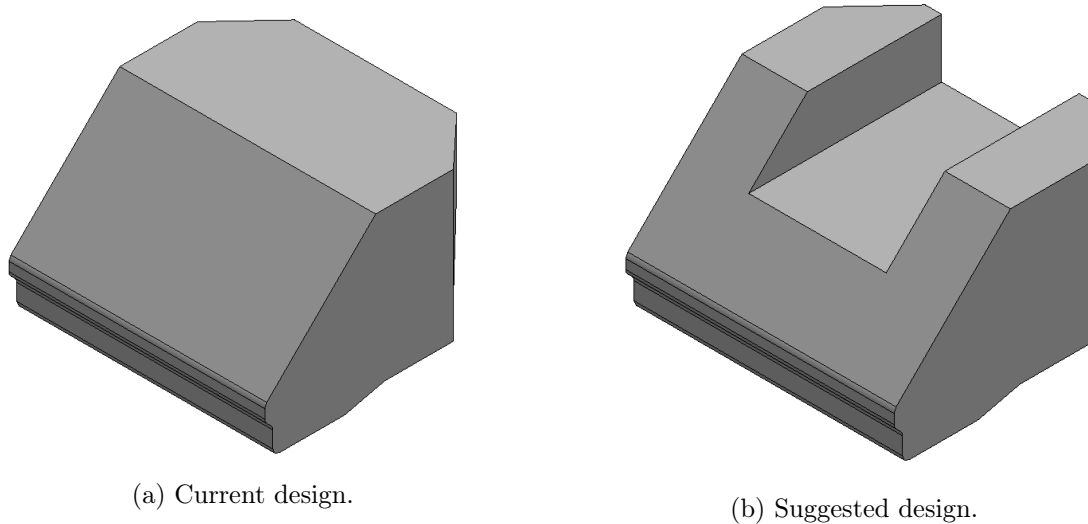

Figure 8.5: CAD overview of suggested divert shoe.

As a result of the front of the sort beam reaching the end of the conveyor before the back part, the front part must bend before the back one. Since the bracket mechanism is responsible for bending both parts of the sort beam, they will bend at the same time crushing the back part against the carrier if no delay mechanism is created for the back part.

The suggested delay mechanism is, to some extent, a spring with the following working principle: when the bracket starts to push the front part of the beam, it also starts to stretch the spring to a certain level. After a certain elongation, the spring will pull the back part of the sort beam in – as soon as the divert shoe starts to go down through the gear, the spring should start to pull the back part.

Likewise the bracket holds the front part of the beam in its position when it is upside down (under the sorter), this connection also has to hold the back part in its position. The suggested solution is to confine the connection in a way that it can only move in one direction, stretching the spring back and forward (see figure 8.6).

An example is shown in figure A14 in annex. The connection between the front and back part works like a bumper: it has a spring on the outer part and inside there is a coupling mechanism that aims to prevent the connection of moving freely in space.

8.3 General Suggestions

Once the design is fully developed, the sort beam should go through a fatigue analysis to determine theoretically its life time. Moreover, brushes need to be attached in order to sort thin parcels and to clean the carrier when the beam is sorting a parcel (see requirement in chapter 4.2.1).

Once the design is validated, it might have openings on the top and side surfaces. Closing them might decrease the flexible behaviour of the model. Therefore, an elastic

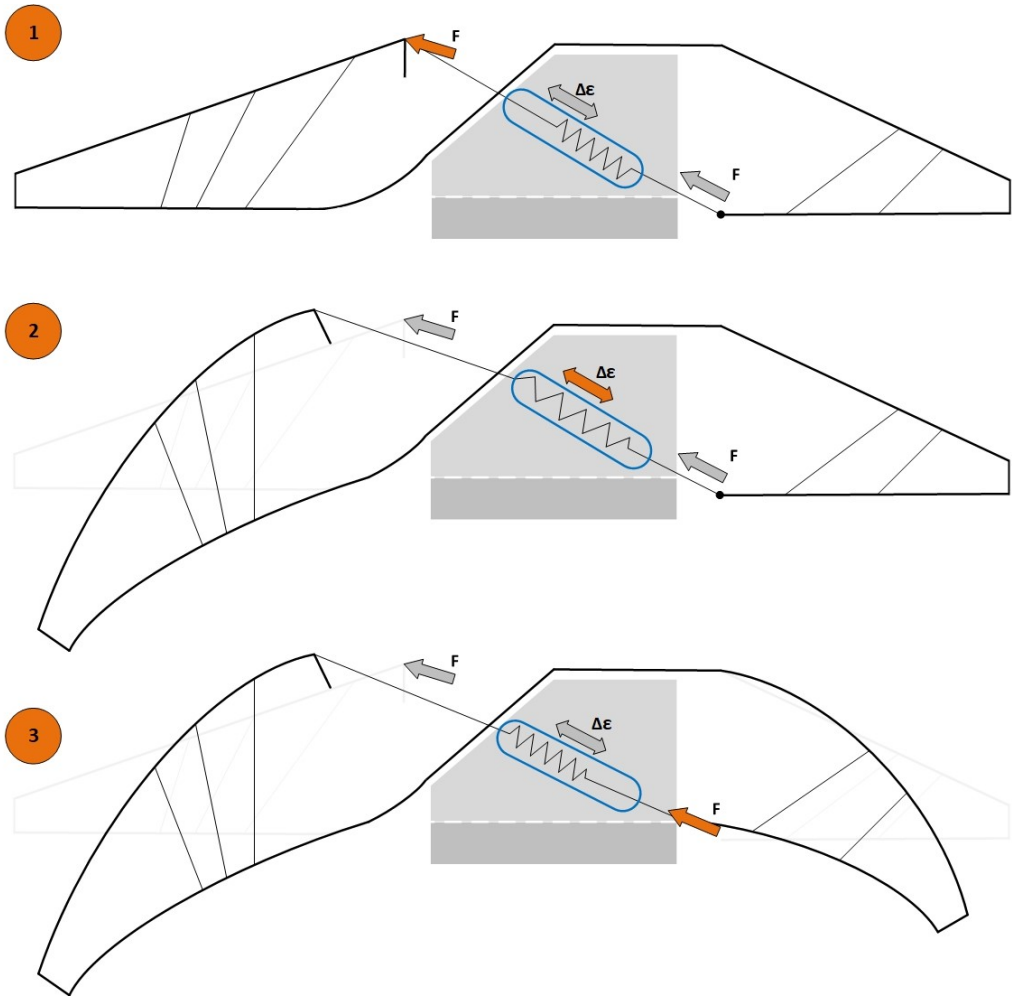

Figure 8.6: Explanation of the suggested bending mechanism.

cap could be used in order to cover those openings (see example in figure A16 in annex). This cap must be elastic enough to handle the bending event.

Chapter 9

Material and Process Selection

Despite the fact that material selection is considered to be independent of the process selection, the compatibility between materials and processes is essential [6].

On one hand, due to the complexity of the design of the model, many of production processes are not applicable. On the other hand, since the sort beam must be flexible, many materials cannot also be chosen (e.g. metal alloys).

9.1 Production Process Selection

Since the main property of the sort beam is flexibility, the most attractive group of materials is plastic. The most common production processes using plastics are shown in table A3 in annex.

Due to the prototype design, some production processes are not ideal or possible to execute as a mass production process (e.g. blow moulding) [6].

Hence, injection moulding is the production process that best suits this case – it is possible to produce a part with detailed features and complex geometry and it is cost (depending on the amount of parts to be produced) and time efficient.

9.2 Material Selection

It is important to be aware of the mechanical properties and prices of the materials suitable for injection moulding. The intended material is a ductile one that can hold the displacement and respective stresses. The maximum stresses should be smaller than the yield stress in order to maintain the model inside the elastic behaviour. Figure 9.1 shows some of the top materials used in the injection moulding industry.

The mechanical properties of the materials presented in figure 9.1 plus LDPE (which was the used material during concept development) are shown in table 9.1.

Several FEM simulations were done with different materials in order to test the maximum displacement of the model and its stresses (see table 9.2). The simulations were done for the following materials: acrylonitrile butadiene styrene (ABS), high density polyethylene (HDPE), low density polyethylene (LDPE), polycarbonate (PC), polyvinyl chloride (PVC-U) and polypropylene (PP).

All the materials could handle the applied force without breaking (comparing the stress values from table 9.2 and the ultimate tensile strength or UTS from table 9.1).

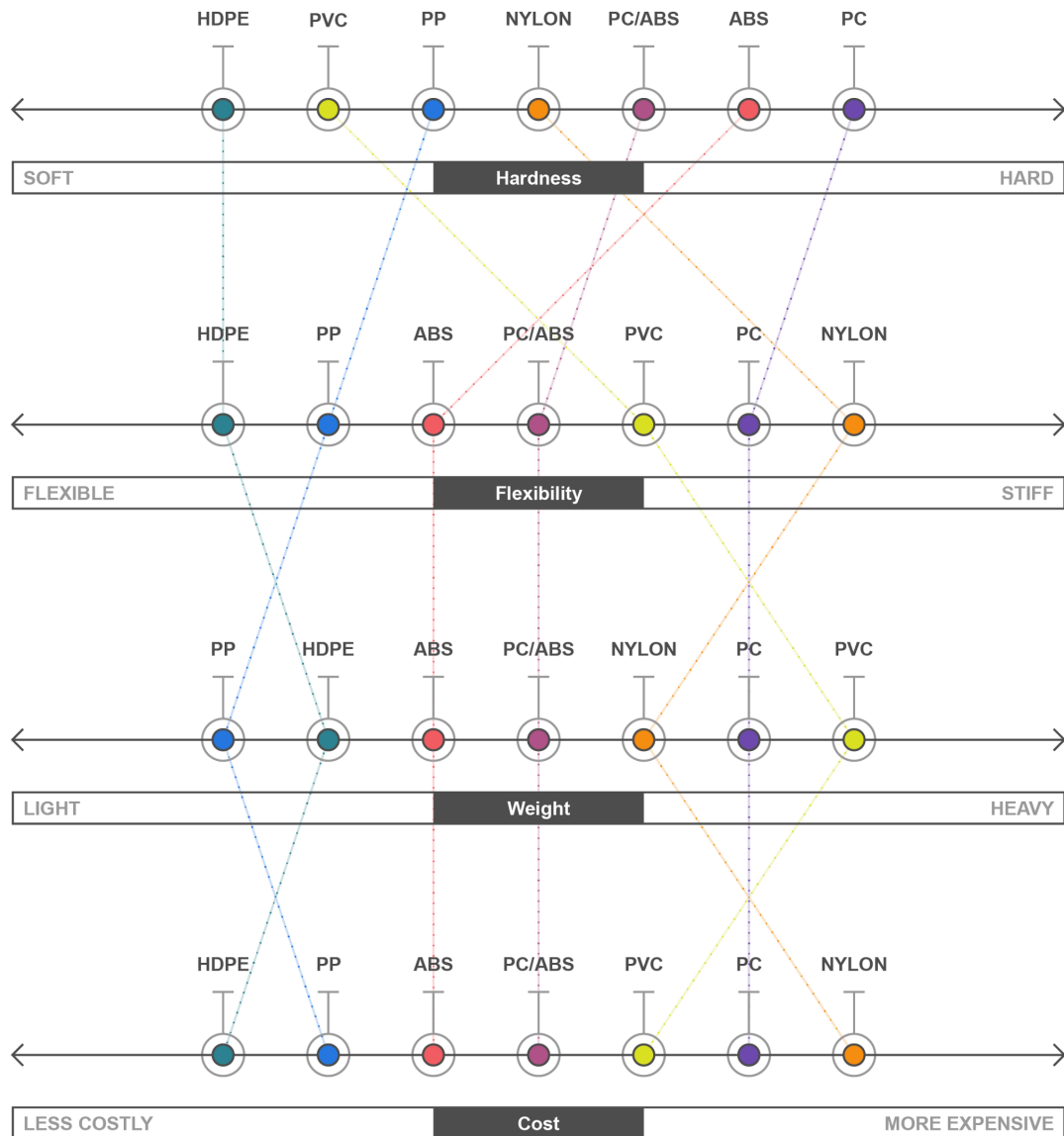

Figure 9.1: Injection moulding plastics properties. [26]

Table 9.1: Range of mechanical properties for various dry engineering plastics at room temperature. [8] [12]

Material	UTS [MPa]	E [GPa]	Elongation Values [%]	Poisson's Ratio [-]
ABS	30 - 55	1.5 - 2.8	2 - 3	0.35
HDPE	20 - 35	0.4 - 1.5	12 - 20	0.41
LDPE	8 - 20	0.15 - 0.6	8 - 14	0.44
Nylon PA 6	60 - 90	1.5 - 2.8	6 - 12	0.32 - 0.40
PC	55 - 70	2 - 2.5	5 - 7	0.38
PP	18 - 38	0.65 - 1.4	10 - 20	0.47
PVC-U	50 - 80	2.9 - 3.6	3 - 7	0.47

Table 9.2: FEM results for different materials.

Material	Maximum Stress [Mpa]	Maximum Displacement [mm]
ABS	9.52	48.9
HDPE	11.4	106.5
LDPE	10.7	108.9
PC	9.12	40.7
PP	11.8	131.1
PVC-U	8.74	39.5

However, since it is also important to bend very easily, the displacement values should be as large as possible. The 3 larger values are for HDPE, LDPE and PP.

HDPE and LDPE have good electrical insulation, very high chemical resistance and they can operate within the range of temperatures of -50°C to 80°C (or 100°C for LDPE) [5]. The yield strength of LDPE and HDPE is approximately 11.5 MPa and 21 MPa, respectively [1] [13].

PP is a semi-crystalline thermoplastic with more favourable mechanical and thermal characteristics than PE, operating up to 110°C . This reason explains why this material usually is more expensive than PE [5]. The yield strength of this material is approximately 30 MPa [1] [16].

By only analysing the yield strength of the materials mentioned above, it is possible to conclude that PP is the one that can withstand the larger deflection in the elastic behaviour.

If quality is a better concern than cost, PP should be chosen. However, since the mechanical properties between PP and PE are similar, if the price difference is considerable, the choice should be PE.

9.3 General Suggestions

It has been shown that PE or PP are the best option for a flexible sort beam. However, since the connection between the front and back part must be rigid, these materials will not fulfil the needs.

Therefore, the sort beam could be made out of 2 materials through injection moulding: a strong plastic (e.g. polyoxymethylene, POM, or polymethyl methacrylate, PMMA) [8] for the rigid part and a flexible one (PP or PE) to the sections that need to bend.

Part VII
Discussion

Discussion

Even though the simulations were tuned throughout the development, the simulated behaviour was always slightly deviated from the real one.

During prototype alpha development, the simulations were relatively close to reality. Yet, when the prototype was tested, new features were found. The last flange on the prototype was not helping the bending event but the opposite – it was adding rigidity to a section of the model that must be flexible. Moreover, the flanges in the front section of the model were not being used. These features were only discovered after the physical test when the bracket behaviour was discovered – this component pushes the sort beam not only forward but also upward. Also, since the carrier can be considered as a flat surface, once the sort beam is bended, the part that stays on top of the carrier does not need to curve/bend. Instead, it can be straight. This prototype was the proof of concept needed to advance and improve the design of a new sort beam.

In behalf of the discovered features from the prototype alpha test, a new model was developed. In this new model the flange in the front of the sort beam was removed because that section can be straight and the last flange was partially removed to let the bracket push the sort beam upward. However, the most important new feature on the new model is the different orientation of the flanges. Their orientation changed approximately 90° clockwise what increased the displacement 85% in comparison to prototype alpha. With this new achievement, the model was also able to bend in the desire section while maintaining the front part straight.

The bracket mechanism was developed side by side with the sort beam. This component is the most important part of the prototype since the entire bending act is caused by itself. From prototype alpha to prototype beta, several brackets were tested aiming to bend the sort beam completely. Meanwhile, a testing set was created in order to see the bracket motion and how it interacts with other system components since the Posisorter is completely closed and the available softwares did not allow to simulate multi-body motion analysis with flexible bodies. The testing set was useful to see the bracket interaction with other components to a certain level. Hence, a bracket was developed on the testing set and it was able to achieve that goal. However, it was applying pressure on the beam when it was on its neutral position. This characteristic makes the sorting event difficult to happen because more force is needed to move the divert shoe in which the sort beam is attached to. Regarding the last result of the bracket, a multi-body mathematical model in MATLAB was coded in order to develop the ideal design for the bracket: a bracket that can bend the sort beam and let it sort parcels with no extra friction or wear. With the generated model, the bracket was redesigned – this new bracket should not apply extra pressure on the sort beam during the sorting event and it has the potential to bend the sort beam completely. Nonetheless, it must be tested to validate the new design.

During the internship period, two prototypes were produced due to the available time. Developing prototype alpha took approximately 2 months. The first one was used to understand the SCO and its problems while the second one was more related with the sort beam and bracket development. During the next month, prototype alpha results were analysed and the development of prototype beta started. After testing prototype beta, the mathematical model for the bracket was developed. During this procedure, extra time was needed from waiting for the arrival of the prototypes to the availability of the Posisorter – this sorter is an important machine that Vanderlande uses to test new prototypes and run fatigue tests in several components.

The available special softwares for this project were Solidworks and MATLAB. Solidworks had some limitations on the simulation package – the available simulation type was *static*. This type of simulation fulfilled the needs during the development of the sort beam. However, during the bracket development, it was not possible to make the bracket push the sort beam and deform it at the same time. A motion analysis could be carried off, but it was not worth it because it was not going to simulate the real forces applied on the bracket – these forces change with the displacement of the sort beam, i.e. as the sort beam bends, larger forces are being applied on the bracket. The needed simulation is a multi-body motion analysis with flexible bodies – Siemens PLM NX offers this possibility.

The project is partially developed. Prototype beta is very close to a final design, if the suggested improvements do not generate other obstacles. Since the adapted Fin Ray mechanism is now understood, the design of the full beam is expected to be more concise and faster than the front part of the beam. Additionally, the bending mechanism to the back part of the sort beam must be developed and its designed possibly tuned. Once the mechanism and design are validated, the sort beam must be tested to sort parcels.

In order to have an overview of the results, tables 9.3 and 9.4 are presented bellow in this chapter. These tables show the current status of the initial requirements from chapter 4.2 plus the requirements that emerged during the development phase, e.g. the requirements for the bracket.

Table 9.3: Primary requirements status.

Primary Requirements	Status
1. Sort both sides	To be tested
2. Handle PHUs	To be tested
3. Interior dimensions	Achieved (see chapter
4. Side surfaces	Capable (see chapter 8.3)
5. Stay on top of carriers	Achieved (see chapter 6.2.2)
6. Imaginary circumference	Achieved (see chapter 6.2.2)
7. Bend 37.5°	Achieved (see chapter 6.2.2)
8. Return to normal position	Achieved (see chapter 6.2.2)
9. Brushes	Capable (see chapter 8.3)
10. Fix to one shoe	Achieved (see chapter 6.1.2)
11. Bracket bending sort beam	Achieved (see chapter 6.2.2)

Table 9.4: Secondary requirements status.

Secondary Requirements	Status
1. Only one part redesigned	Achieved (see chapter 6.2)
2. Replace function of 3/4 shoes	Capable (see chapter 8)
3. Temperature and humidity range	Achieved (see chapter 9.2)
5. Lifetime	To be tested
6. Horizontal position	Achieved (see chapter 6.2.2)
7. Handle conveyor acceleration	To be tested
8. Handle sorting acceleration	To be tested
9. Screws holding sort beam	Capable/To be tested (see chapter 6.2.2)
10. Carrier flange gap	Capable/To be tested (see chapter
11. Sort beam height	Achieved (see chapter
12. No. of parts	Failed, more than 1 part (see chapter 6.1.1)
13. Bend in 0.31 s	To be tested
14. Sorting robustness	To be tested
15. Bracket deformation	Achieved (see chapter 6.2.2)
16. Bracket interference	Capable/To be tested (see chapter 7)
17. Parts wear	Capable/To be tested (see chapter 7)
18. Bracket length	Capable/To be tested (see chapter 7)
19. Bracket width	Achieved (see chapter 7)

Part VIII
Conclusion

Conclusion

The results (see chapter 6.2.2) have shown the benefits of a bended sort beam on the SCO. The performance of the early prototype was substantial.

Tests and analysis done to the prototypes showed the potential that a flexible sort beam has in the respective sorter. During the tests, especially with prototype beta, it was shown that the performance of the model was good and the end result can be ambitious.

Once the sort beam is completely developed and validated, the competitiveness of the company will increase because there is nothing close to a flexible sort beam in the market.

The main goal of the project was achieved: the sort beam stayed on top of the carrier the entire time. This solution, when applicable to the back part of the sort beam, will bring safety and financial benefits to the SCO and company, respectively. The safety tunnel in the end of the SCO can be removed because there will be no sharp parts moving considerably fast close to the operators – safety gain regarding all the operators and financial boost since the sorter will need less parts than before.

Due to the weight of the current sort beam, vibrations are generated after it already goes down in the drive section what can damage the system on the long run. Comparing to the flexible sort beam, these vibrations will be reduced (the flexible body should absorb some of the vibrations instead of the divert shoe and carrier) or even neglected them (event that depends on the smoothness of the bracket mechanism). When the vibrations are reduced, the noise of the sorter will also decrease – even though some vibrations might be present, the sound of plastic hitting metal is lower than metal hitting metal.

Besides the safety, vibrations and financial gain, less energy will be used to move the sorter. The weight of the new sort beam will be approximately 4 times less than the current one. In a 200 m long sorter, this represents a decrease in weight of almost a 1000 kg.

Since the height of the sort beam is 20 mm on the tip, the flange of the carrier can also be decreased in height and, if possible, changed from a metal flange to a rubber one, what is decrease the risk of damage in the case of machine-human interaction.

Last but not least, there is a big opportunity to the company to standardise the drive section of the SCO – most of the sorters that the company produces have the same drive section while the SCO has a different one due to the current sort beam.

When the final prototype is ready to be assembled and tested, machine operators should be also present – the people that work everyday with a certain machine know more about it than the people that developed it.

Annex

This chapter has supplementary figures and tables that help understanding the information in this document.

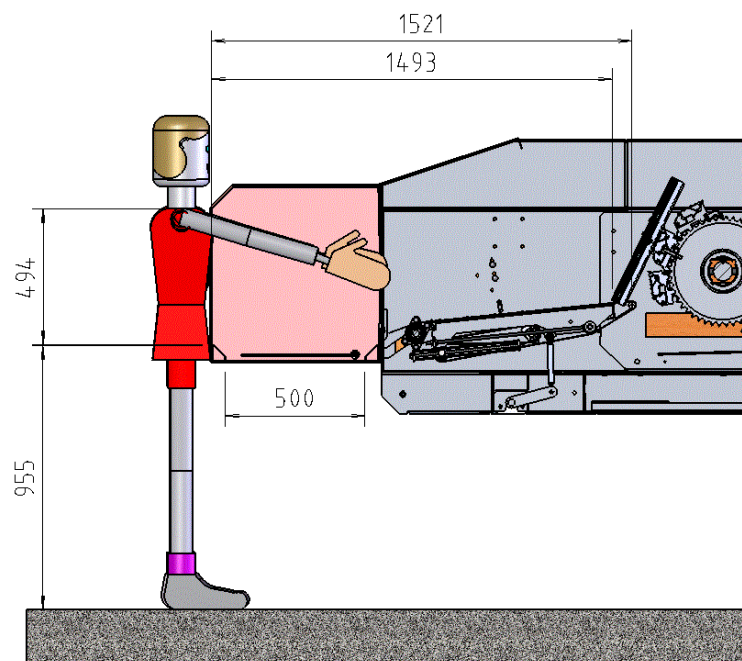

Figure A1: User interaction with safety tunnel.

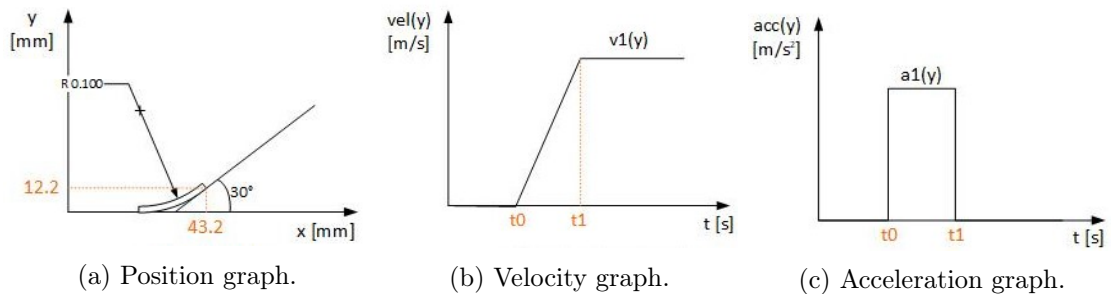

Figure A2: Position, velocity and acceleration graphs on the switch frame.

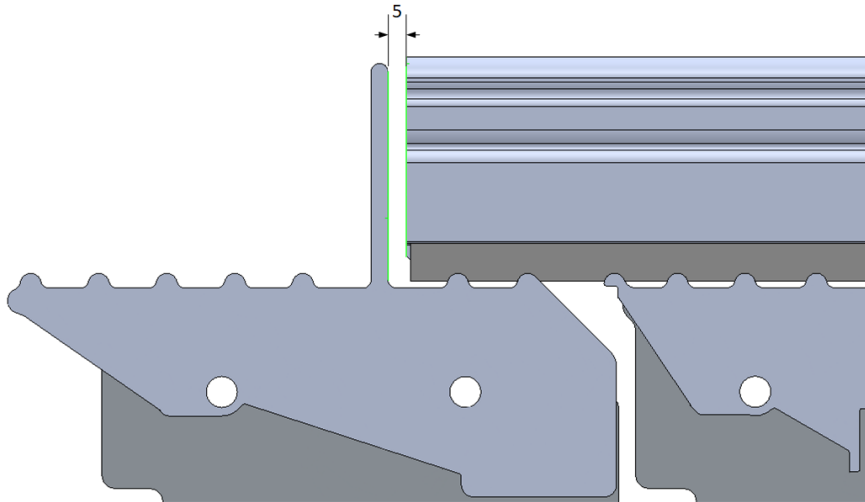

Figure A3: Distance between the carrier flange and current sort beam.

Table A1: Concept analysis matrix overview.

Rating Requirements Importance: →		B								
		1	2	3	4	5	6			
Key Requirements: →		A						Total	Concept Analysis	Rank
Nr.	Concepts	↓ Concept main feature:								
1										
2										
3										
4										
5	C									G
6										
7										
8										
9										
Perfect		E								
Total :										
Lower Spec		F								
Target										
Requirement Analysis										

Table A2: Detailed decision analysis.

Decision Analysis SCO Sort Beam: Redesign the COMPAXORTER sort beam to increase system safety		1		2		3	
		Fin Ray concept		Sliding concept		Butterfly concept	
		Performance	Weighted Perf.	Performance	Weighted Perf.	Performance	Weighted Perf.
<p>Develop objectives What results do we want? What resources should we use or save? What restrictions do we have? What objectives need to be more specific?</p> <p>Classify objectives If the objective is mandatory, essential, and desirable, label it a must (M).</p> <p>Screen through MUSTS / Compare against WANTS Performance MUST eliminate any other alternatives that do not meet all MUST objectives. Record information on WANTS. Rate the performance of each alternative against the WANTS objectives. Record information on performance.</p>							
Main requirements							
R1) Sort parcels	Y/N	Y		Y		Y	
R2) Fit on top of a shoe	Y/N	Y		Y		Y	
R3) Fixed in one shoe only	Y/N	Y		Y		Y	
R4) Bend in the charge/discharge sections	Y/N	Y		T.B.D.		T.B.D.	
R5) Bend in 0.31 s	Y/N	Y		Y		Y	
R6) Handle 15 kg (maximum) PHU's	Y/N	Y		Y		Y	
R7) Made out of 1 part	Y/N	Y		N		Y	
R7) No patent infringement	OK/NOK	T.B.D.		T.B.D.		T.B.D.	
Criteria							
		Performance	Weighted Perf.	Performance	Weighted Perf.	Performance	Weighted Perf.
Generic Unique Selling Points (25%)	Weight factor						
W1) Ability to bend	10	8	80	6	60	7	70
W2) No interference with parcel which is incorrectly positioned in its compartment (e.g. on top of the beam)	10	10	100	8	80	8	80
W3) Increase safety of the SCO	15	9	135	8	120	8	120
W4) Sort parcels	15	9	135	9	135	9	135
W5) Robustness (Durability)	10	7	70	6	60	6	60
W6) Life Time	10	7	70	8	80	7	70
W7) Easy and quick beam change (SMED)	5	10	50	9	45	9	45
W8) No need to change any other system's parts	5	10	50	10	50	10	50
W9) Availability of spare beams (Supply chain)	2	8	16	8	16	8	16
W10) Number of total parts (the less the better)	3	6	18	6	18	6	18
W11) Low overall cost (production, maintenance)	7	8	56	7	49	8	56
W12) Production Costs	4	7	28	7	28	9	36
W13) Development costs (NRE)	4	7	28	7	28	7	28
Total		836		769		766	
Rate		16,7		15,4		15,3	
Rank		1		2		3	

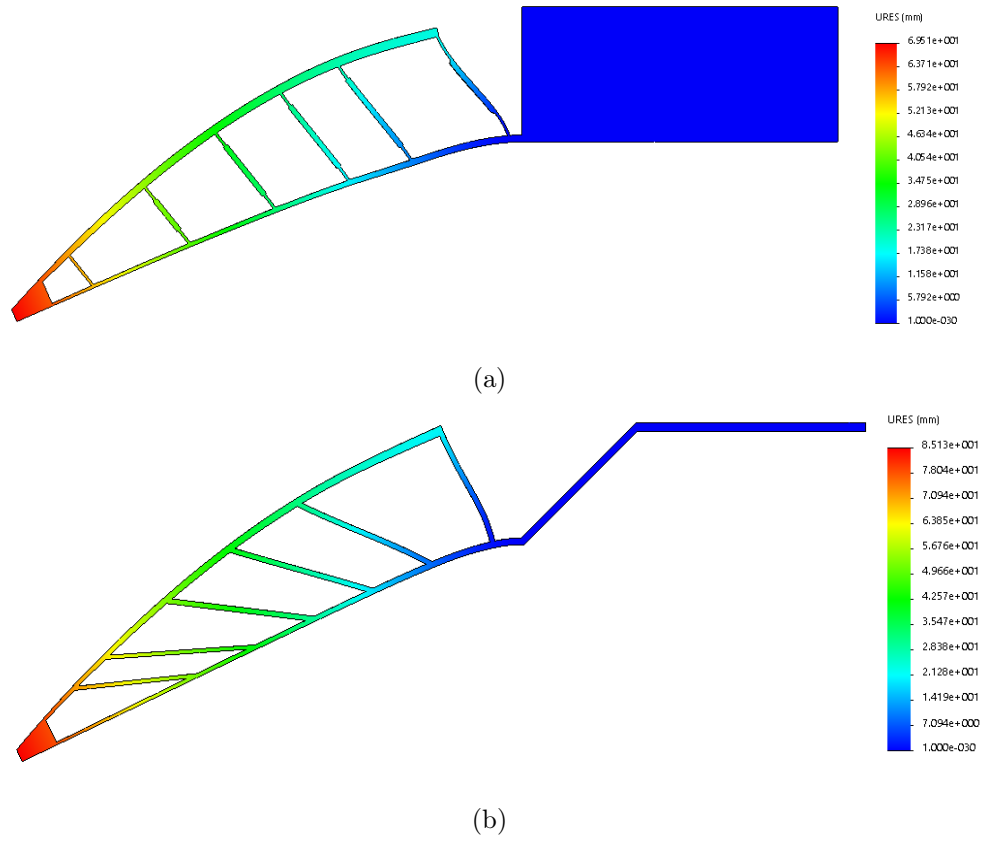

Figure A4: FEM simulation displacement results for two different designs.

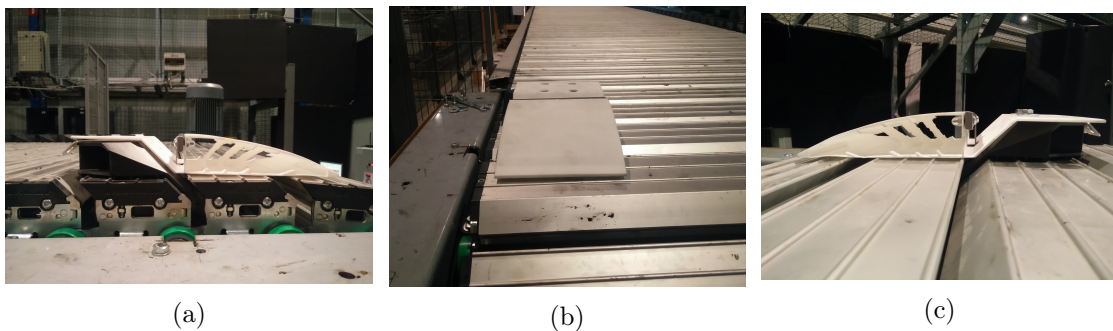
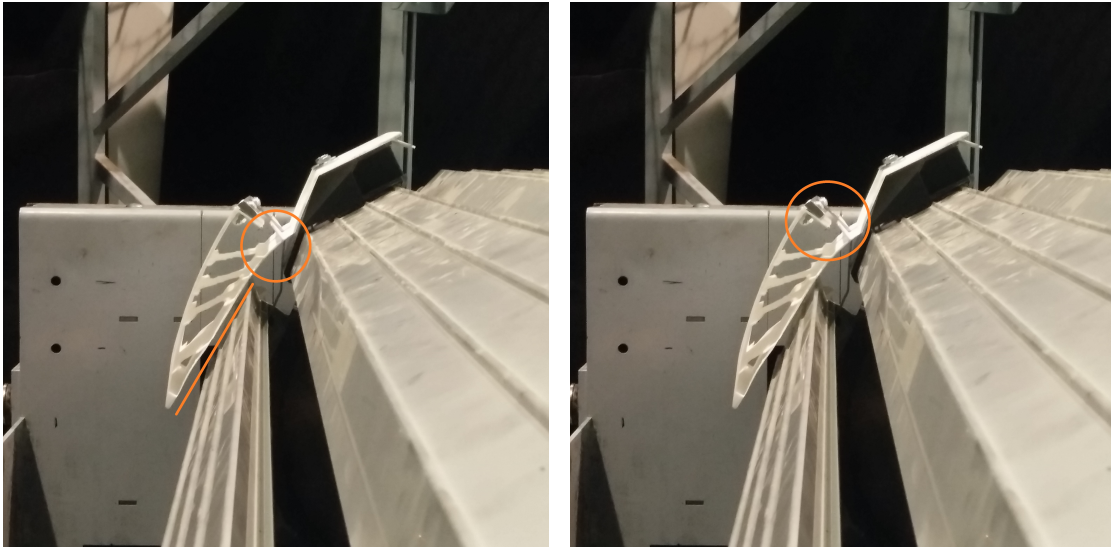

Figure A5: Prototype alpha mounted in Posisorter.



(a) Bended and flat sections after the test.

(b) Bracket interference with sort beam.

Figure A6: Prototype alpha results analysis.

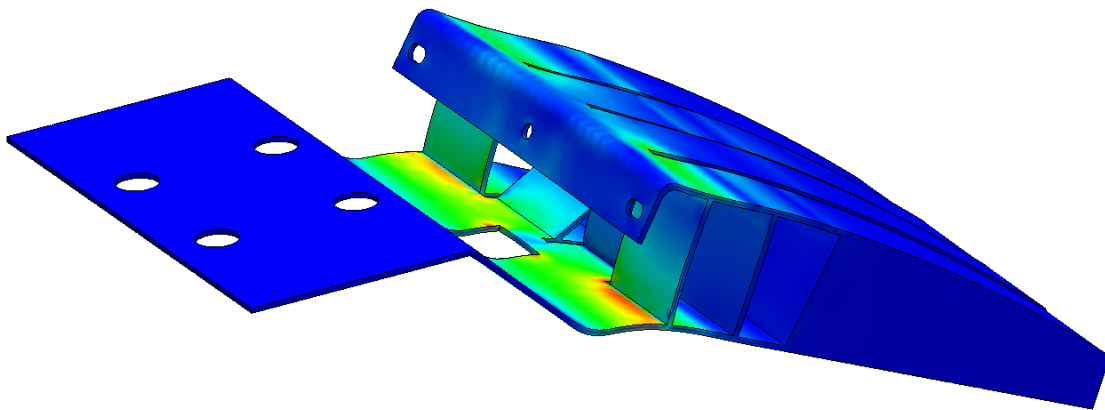

(a) Side view.

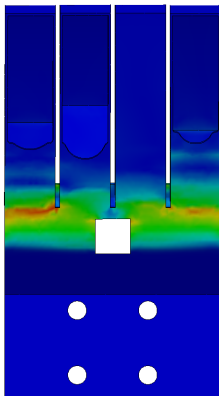

(b) Bottom view.

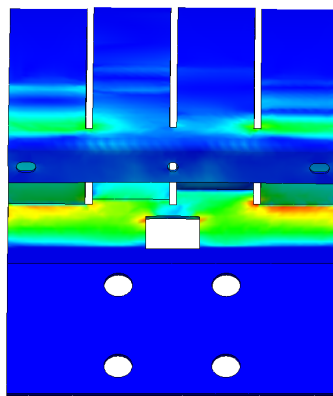

(c) Back view.

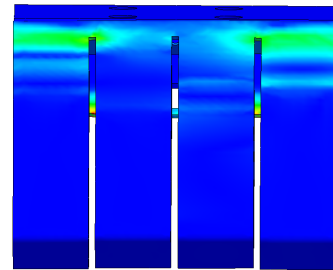

(d) Front view.

Figure A7: FEM stress results of the new study model.



(a)



(b)

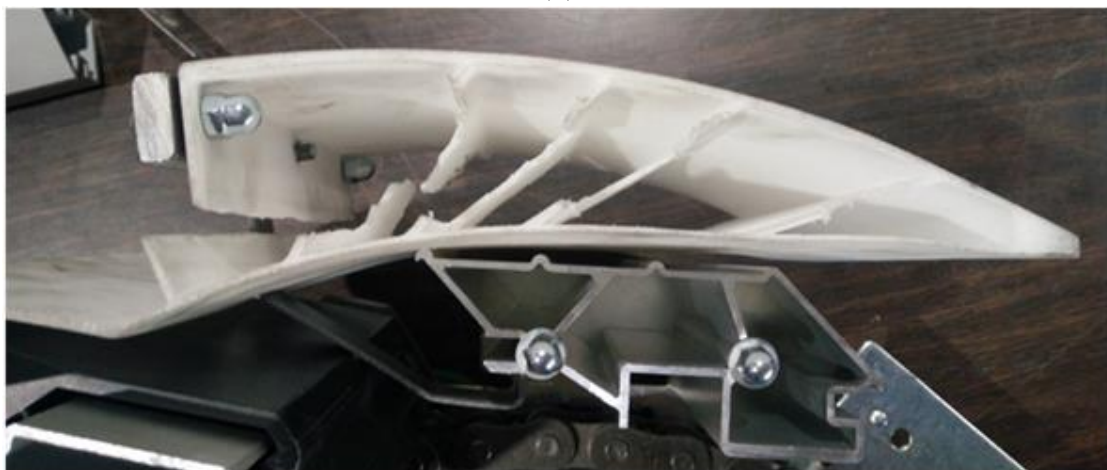

(c)

Figure A8: Bending moments of the iterated bracket.

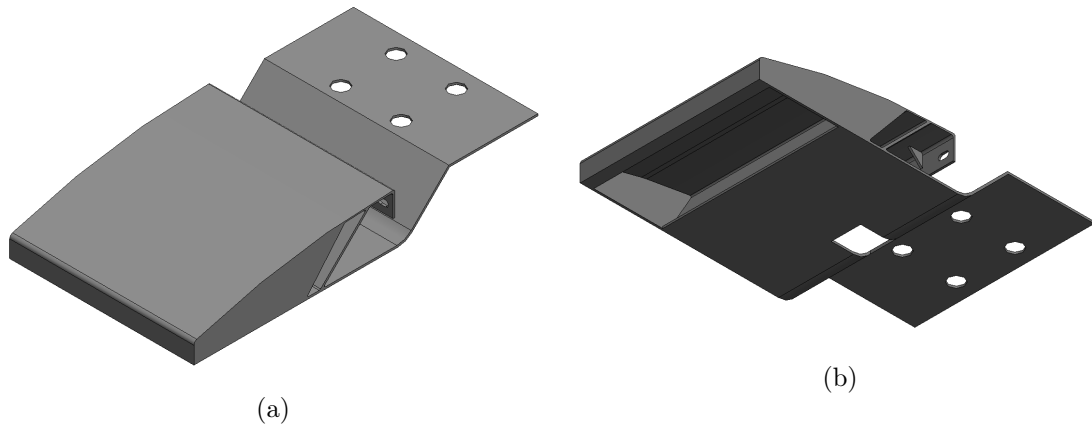

Figure A9: Side surface and bottom modification on prototype beta.



(a) Initial position.



(b) Position when the sort beam is fully bended.



(c) Position when the sort beam is coming back to its neutral shape.



(d) Final position.

Figure A10: Bracket position stages.

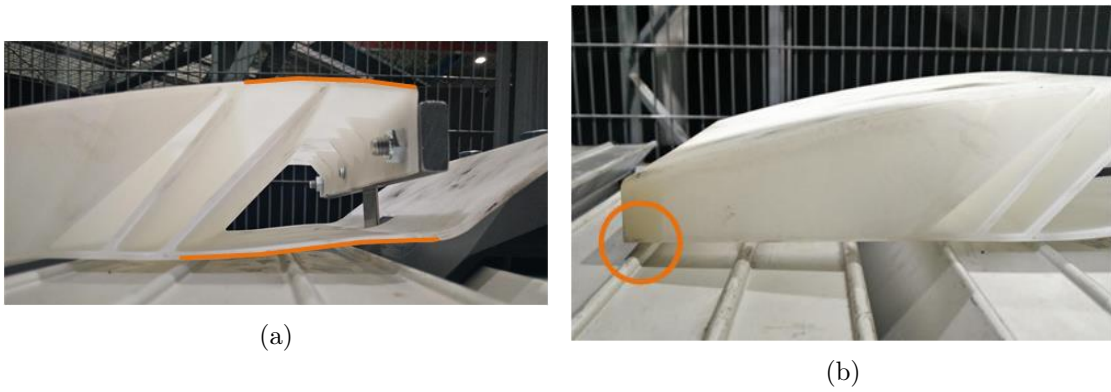

Figure A11: Reaction of prototype beta to the bracket pressure.

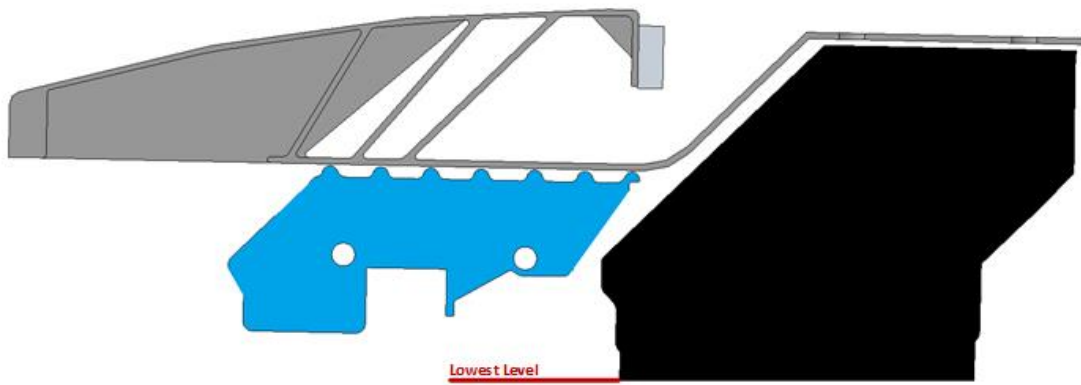

Figure A12: Limit for the bracket.

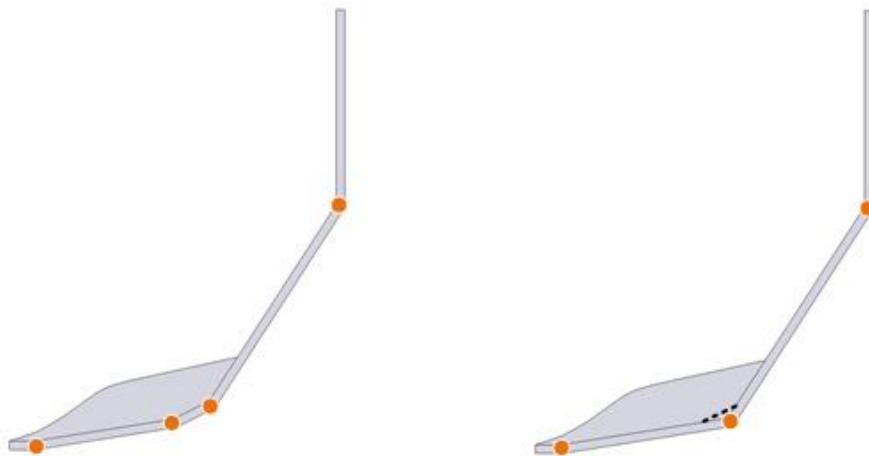

Figure A13: MATLAB iterated brackets differences.

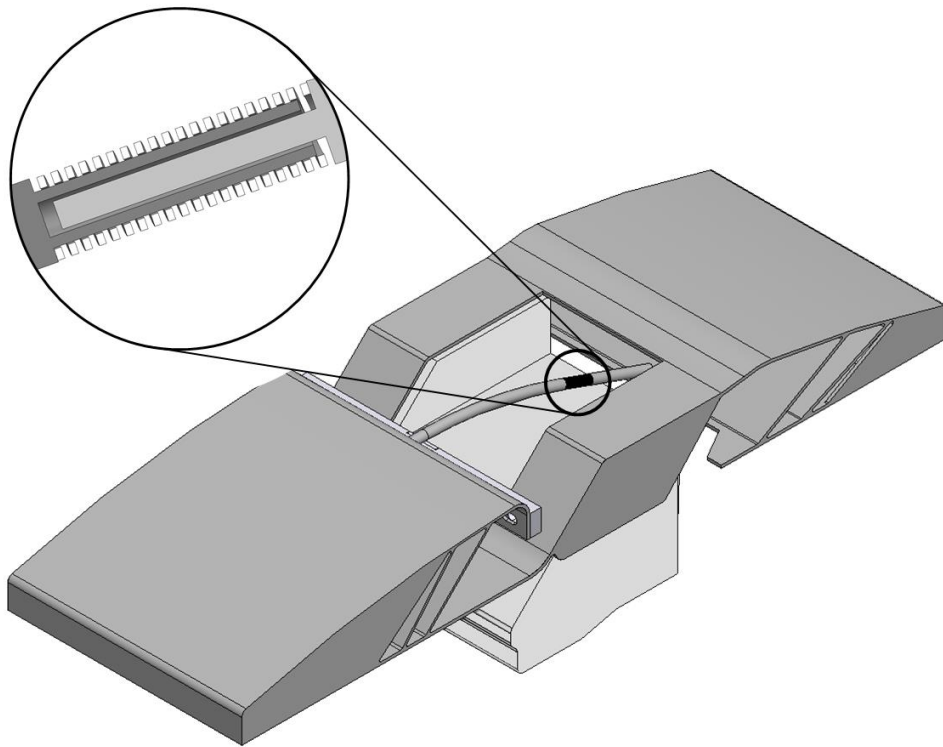

Figure A14: Example of suggested sort beam.

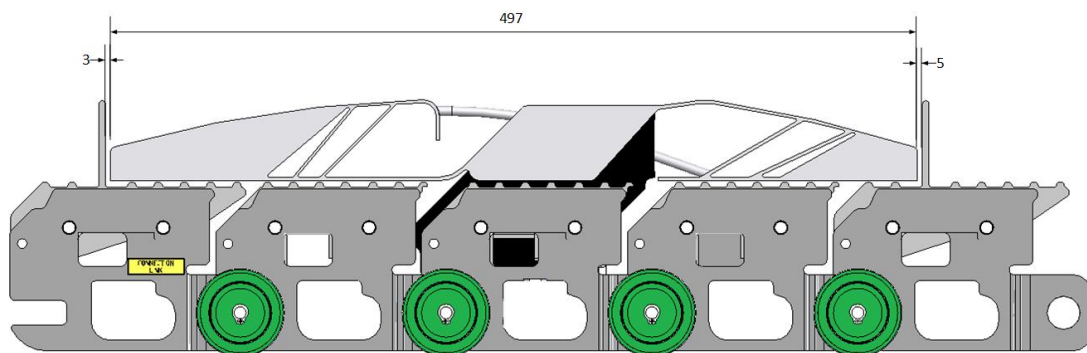

Figure A15: Suggested sort beam length.



Figure A16: Example of the sort beam cover.

Table A3: Thermoplastics processing methods. [11] [12]

Thermoplastics Processing Methods	Characteristics
Injection Molding	<ul style="list-style-type: none"> - Forcing molten plastic into molds at high pressure; - Quick-cycle process, large quantities of parts, wide variety of part sizes, excellent part-to-part repeatability, tight tolerances.
Extrusion	<ul style="list-style-type: none"> - Molten material continuously passes through a die that forms a profile; - High production rates, inexpensive for simple profiles; - Holes and notches require secondary operations.
Blow Molding	<ul style="list-style-type: none"> - Air pressure applied to a hanging extruded tube expands and forces it against the walls of the hollow mold; - Production of hollow items such as bottles.
Thermoforming	<ul style="list-style-type: none"> - Creates shapes from a thermoplastic sheet that has been heated. Vacuum or pressure draws the softened sheet over an open mold; - Lower costs than injection molding, production of large parts; - Holes and cutouts require secondary operations.
Rotomolding	<ul style="list-style-type: none"> - Thermoplastic resin is placed and inside a heated mold. As the mold rotates, the resin coats the heated mold surface; - Production of hollow shapes with large open volume; - Low costs, low production quantities for large parts, long cycle-times.

Bibliography

- [1] M. Akay. *Introduction to Polymer Science and Technology*. Ventus Publishing ApS, 2012.
- [2] Y. Asiedu and P. Gu. Product life cycle cost analysis: State of the art review. *International Journal of Production Research*, 36(4):883 – 908, 2010.
- [3] C.I. Basson, G. Bright, and A.J. Walker. Testing flexible grippers for geometric and surface grasping conformity in reconfigurable assembly systems. *South African Journal of Industrial Engineering*, May 2018, 29(1):128–142, 2018.
- [4] F.P. Beer, E.R. Johnston, J.T. DeWolf, and D.F. Mazurek. *Mechanics of Materials – 6th ed.* McGraw-Hill, The McGraw-Hill Companies, Inc., 1221 Avenue of the Americas, New York, NY 10020., 2012.
- [5] W. Beitz, K.H. Kutter, and M.J. Shields. *Dubbel: Handbook of Mechanical Engineering*. Springer-Verlag London Limited 1994, Great Britain, 1994.
- [6] G. Boothroyd, P. Dewhurst, and W. Knight. *Product design for manufacture and assembly*. Marcel Dekker, Inc., 270 Madison Avenue, New York, New York 10016, United States of America, 1994.
- [7] W. Crooks, G. Vukasin, M. O’Sullivan, W. Messner, and C. Rogers. Fin ray effect inspired soft robotic gripper: From the robosoft grand challenge toward optimization. *Frontiers in Robotics and AI*, 3(1):70, 2016.
- [8] Bayer Polymers Division. *A Processing Guide for Injection Molding*. Bayer Corporation, 1995.
- [9] FESTO. Getting to grips with the adaptive gripper dhdg. 2011.
- [10] FESTO. *MultiChoiceGripper – Variable gripping based on the human hand*. <https://www.festo.com/group/en/cms/10221.htm> (consulted in June 2019), 2019.
- [11] Covestro LLC Applications Development Group. Engineering polymers – part and mold design thermoplastics – a design guide. 2015.
- [12] S. Kalpakjian. *Manufacturing engineering and technology – 3rd ed.* Addison-Wesley Publishing Company, Inc., United States of America, 1995, 1992, 1989, 1995.
- [13] Y.V. Kissin. *Polyethylene: End-Use Properties and their Physical Meaning*. Carl Hanser Verlag, 2012.

-
- [14] L. Kniese. *Bauteil zur Aufnahme von KrÄZften, mit einer flexiblen Aussenhaut*. Scholz, Hartmut, Dipl.-Ing., Patentanwalt, Rheinstrasse 64, 12159 Berlin (DE), 1999.
- [15] Y.L. Lee, J. Pan, R. Hathaway, and M. Barkey. *Fatigue Testing and Analysis (Theory and Practise)*. Elsevier Inc., Oxford, UK, 2005.
- [16] C. Maier and T. Calafut. *Polypropylene: The Definitive User's Guide and Databook*. William Andrew Inc., 1998.
- [17] A. Mital, A. Desai, A. Subramanian, and A. Mital. *Product Development: A Structured Approach to Consumer Product Development, Design, and Manufacture*. Elsevier Inc., 2015.
- [18] H.C. Mohring, C. Brecher, E. Abele, J. Fleischer, and F. Bleicher. Materials in machine tool structures. *CIRP Annals*, 64(2):725 – 748, 2015.
- [19] N. Nes and J. Cramer. Influencing product lifetime through product design. *John Wiley & Sons, Ltd. and ERP Environment*, 14(5):286 – 299, 2005.
- [20] O. Pfaff, S. Simeonov, I. Cirovic, and P. Stano. Application of finray effect approach for production process automation. *DAAAM International*, 22(1):1726 – 9679, 2011.
- [21] W.D. Pilkey. *Peterson's stress concentration factors – 2nd ed.* John Wiley & Sons, Inc., 605 Third Avenue, New York, NY 10158-0012, United States of America, 1997.
- [22] C. Relvas. *Design & Engenharia: da ideia ao produto*. Publindústria, Edições Técnicas, 2017.
- [23] T. Ritchey. Problem structuring using computer-aided morphological analysis. *Journal of the Operational Research Society*, 57(1):792 – 801, 2005.
- [24] N.F.M. Roozenburg and J. Eekels. *Productontwerpen, structuur en methoden*. UIT-GEVERIJ LEMMA BV., Postbus 3320, 3502 GH Utrecht, 1998.
- [25] P. Schellekens, N. Rosielle, H. Vermeulen, M. Vermeulen, S. Wetzels, and W. Pril. Design for precision: Current status and trends. *CIRP Annals*, 47(2):557 – 586, 1998.
- [26] Jaycon Systems. Selecting the right material for injection molding. 2019.
- [27] H.C. Theisens, D. Harborne, and T.J. Hesp. *Lean Six Sigma Green Belt – Mindset, Skill set and Tool set (4th edition)*. LSSA BV, 2018, Amstelveen, the Netherlands, 2018.
- [28] M. Zaeh and D. Siedl. A new method for simulation of machining performance by integrating finite element and multi-body simulation for machine tools. *CIRP Annals*, 56(1):383 – 386, 2007.