

IOP Conference Series: Materials Science and Engineering

PAPER • OPEN ACCESS

Design of a small size PTC: computational model for the receiver tube and validation with heat loss test

To cite this article: M Salvestroni *et al* 2019 *IOP Conf. Ser.: Mater. Sci. Eng.* **556** 012025

View the [article online](#) for updates and enhancements.

Design of a small size PTC: computational model for the receiver tube and validation with heat loss test

M Salvestroni¹, G Pierucci¹, F Fagioli¹, A Pourreza¹, M Messeri¹, F Taddei¹, S Hosouli¹, H Rashidi¹ and M De Lucia¹

¹ Department of Industrial Engineering of University Of Florence,
Via di Santa Marta 3, 50139 Florence – Italy
E-mail: michele.salvestroni@unifi.it

Abstract. In EU, the residential sector is responsible for the 40% of the total energy consumption. The integration of solar technologies in buildings is therefore necessary in order to reduce the use of fossil fuels. Concentrating collectors could offer an interesting solution but nowadays their application in buildings is rare due to high costs, large dimensions and complexity of the system. A novel small parabolic trough collector (PTC) has been conceived to overcome these limits and to allow the integration in buildings. The main features of realized prototype are the compact dimensions, strongly reduced compared to the PTC standards, and modularity. The paper deals with the numerical analysis necessary to design the concentrating collector properly and its validation with experimental results. An optical analysis has allowed to select the optimum values for the parameters of the parabola, aperture and rim angle. A thermo-fluid dynamics finite element model has been developed with Comsol Multiphysics, to analyse the relevant physical characteristics and to predict the performance of the receiver tube. The efficiency curve of the collector has been extracted. Successively a receiver tube has been built based on the indications of FEM model for what concerns geometry and materials. In order to evaluate the heat loss of the receiver and to validate the finite element model, a test bench has been realized. The results of off-sun heat loss tests on the receiver tube are reported for several temperatures. The computational model is in good agreement with experimental results and therefore it is validated.

Keywords: Small size parabolic trough, receiver tube, FEM model, buildings

1. Introduction

In EU, the residential sector is responsible for the 40% of the total energy consumption [1]. The integration of solar technologies in buildings is therefore necessary in order to reduce the use of fossil fuels and the emissions of greenhouse gases caused by buildings.

Regarding the production of heat for domestic heating, solar thermal collectors are a mature technology. Nevertheless, they still exhibit some problems, for instance a remarkable drop in efficiency when the fluid temperature grows; for this reason flat plane and evacuated solar collectors are not adequate for solar cooling. Concentrating collectors could offer an interesting solution but at the moment their application in buildings is strongly limited due to high costs, large dimensions and complexity of the system.

The cooling demand in EU, especially in Mediterranean area has been growing considerably in recent years; therefore, an open task is developing an economic and compact solar collector suitable to produce heat at medium temperature (up to 200°C) to exploit it in absorption cycle for refrigeration.

For these reasons, a novel small size parabolic trough collector (PTC) has been conceived. In order to realize a compact system suitable to be integrated on the roof, the dimensions of the prototype collector (mirror, receiver tube) have been strongly reduced compared to the PTC standards.



An accurate design phase has preceded the construction of a prototype. A numerical analysis from an optical and thermal point of view has been conducted.

The prototype of the receiver has been realized based on the indications of FEM (finite element method) model for what concerns geometry and materials.

2. Optical analysis and FEM model

2.1 Optical analysis

The aim of the project is to build a compact concentrating collector, suitable to be installed on the roof.

The design phase of the small size parabolic trough collector has started with an optical analysis that has allowed to choose the optimum values for the parameters of the parabola, aperture and rim angle.

In order to have a compact object the aperture should be equal or less than 1 m. The diameter of the receiver has been selected as a trade-off between concentration ratio and minimum acceptable dimensions. For these reasons, the aperture has been fixed to about 500 mm and the external diameter of absorber tube has been set to 10 mm.

The shape of parabola has been determined through an optical analysis with ray-tracing software. The optical errors (angular width of the sun, micro and macro imperfection of the parabolic shape, etc.) have been estimated and applied in the analysis. For a beam spread of about 0.9° , it has been found that the rim angle that maximizes the irradiance on receiver tube, is 110° . **Figure 1** shows the irradiance distribution on the receiver tube obtained. As can be seen, along the circumference of the absorber tube the irradiance is non uniform, since the upper part of the receiver (corresponding to the positions close to 0.15 and -0.15 on the horizontal axis in the plot) receives only direct radiation while the lower part gets the reflected radiation from the mirror.

2.2 FEM Model

The second stage of the design phase deals with the finite element model developed in order to analyse the relevant physical characteristics and to predict the performance of the receiver.

The model is a 3d thermofluid dynamic model of the receiver tube. It describes the dynamic of the fluid inside the absorber tube and the heat transfer between all the components of the receiver. Several numerical models are present in literature [2-8]. The flux obtained through a ray-tracing software is applied on the outer boundary of absorber tube.

A novel geometry solution is considered; two concentric tubes are inserted in an evacuated glass envelope, so that the fluid inlet and output are at the same side of One-End receiver. This configuration is simpler to build, performant and much more economic than the standard one. The inner absorber tube has an external diameter of 5 mm. The geometry and the domains of the computational model are shown in **Figure 2**.

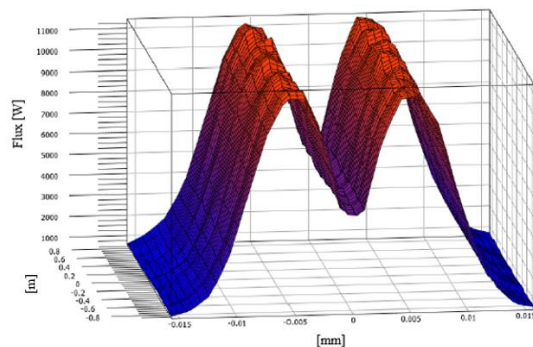

Figure 1 Solar flux distribution on the absorber tube obtained by Soltrace.

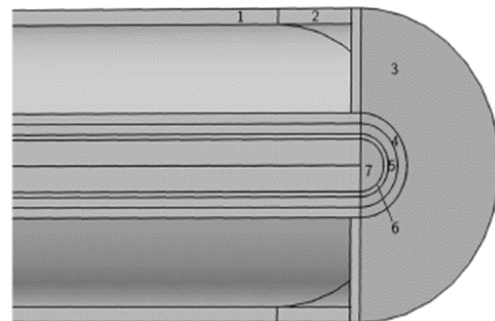

Figure 2 1) Glass; 2) Kovar; 3) Metal surface; 4) Outer absorber tube; 5) Fluid domain; 6) Inner absorber tube; 7) Fluid domain.

The model solves the continuity equation and the momentum equation in the fluid domain, the energy equations in all domains. A k-e turbulence model with wall function is used when the flow regime is turbulent.

The main boundary conditions are:

- the solar flux distribution obtained by the optical analysis is imposed on the outer absorber surface;
- radiation boundary condition on the inner boundary of glass envelope and on the outer boundary of the absorber; no convection inside the annulus since it is supposed to be under high vacuum, 10^{-4} mbar;
- convection and radiation on the external surface of the glass tube.

A parametric analysis has been conducted to investigate the performances of the receiver under different conditions for mass flow, inlet temperature, absorber tube materials, emissivity of the coating, irradiation, etc. Part of the results are reported below.

Figure 3 shows the results varying the inlet flow velocity. The optimal velocity has been selected as the one that maximize thermal efficiency and minimize pressure losses.

Figure 4 shows the results of thermal efficiency varying the emissivity of coating. Comparing the performances at 180°C of an optimum selective coating (5% of emissivity), and a medium selective coating (15% of emissivity), the deviation in efficiency between them is only 2%. Thus, it is possible to choose a more economic coating without a significant loss in thermal performances.

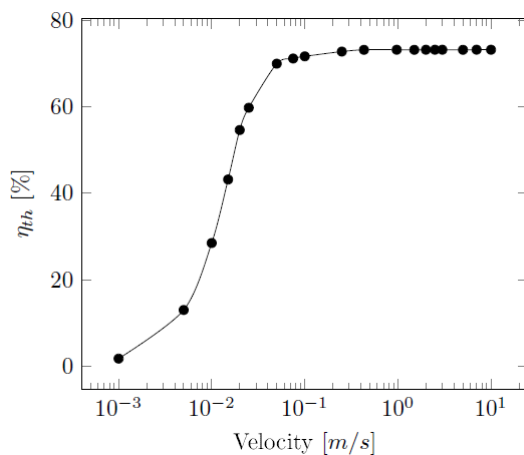

Figure 3 Thermal efficiency for different velocity of the flow.

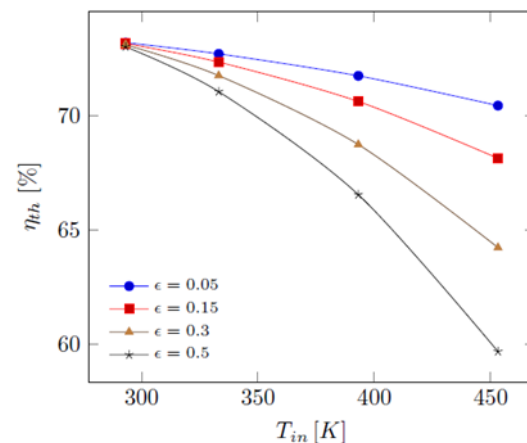

Figure 4 Sensitivity analysis: thermal efficiency vs coating emissivity.

Figure 5 shows the thermal efficiency versus fluid inlet temperature. The dot line represents the optical efficiency of receiver, calculated by tracing software, fixing the reflectivity of the mirror, the transmittance of the glass and the solar absorbance of the coating. The selective coating used for this simulation has emissivity equal to 0.15.

The optical efficiency of the small PTC is evaluated to be about 73%, due to the shape of the parabola and to the properties of materials. The latter are a trade-off between good performances and low costs. The drop in thermal efficiency at 180°C is only 5% thanks to vacuum in the annulus and to selective coating.

The increase of temperature inside the collector varying inlet fluid temperature for different conditions of solar irradiance reported in **Figure 6**. For an inlet fluid temperature of 25°C a rise of about 6°C is predicted at 800 W/m^2 .

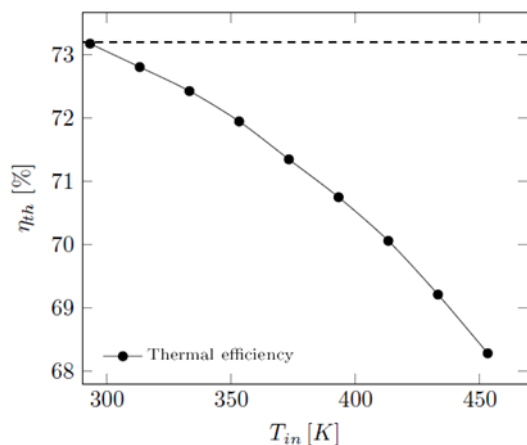

Figure 5 Thermal efficiency vs inlet flow temperature.

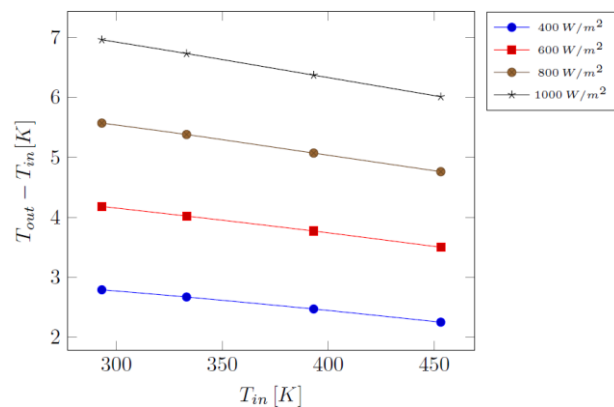

Figure 6 Temperature rise on the collector varying inlet fluid temperature for different irradiance conditions.

Steel, copper and aluminium have been investigated as absorber material; no so much thermal efficiency differences have been found. Therefore, the absorber material has been chosen based on structural and economic reasons.

A structural mechanic FEM model has been realized to verify the thermal stresses on receiver tube due to the non-uniform incident solar flux. The stresses evaluated by the numerical model are under 30 MPa, as can be seen in **Figure 7**, well below the yield stress of the materials tested.

The vertical displacement due to thermal stress reported in **Figure 8**. The inner absorber tube leans on the outer tube since it is free to move. The outer absorber tube properly constrained with springs to the glass tube, remains in the initial position without moving away from focus position. Finally, copper selected as absorber material.

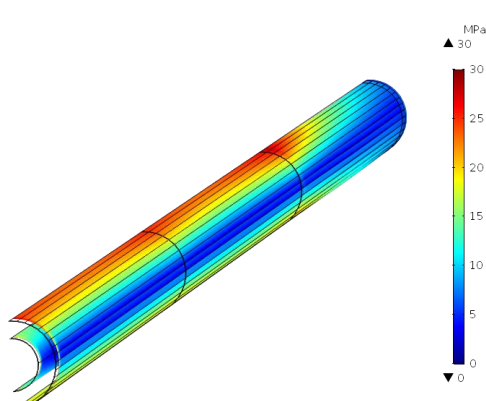

Figure 7 Von Mises stress on the outer absorber tube.

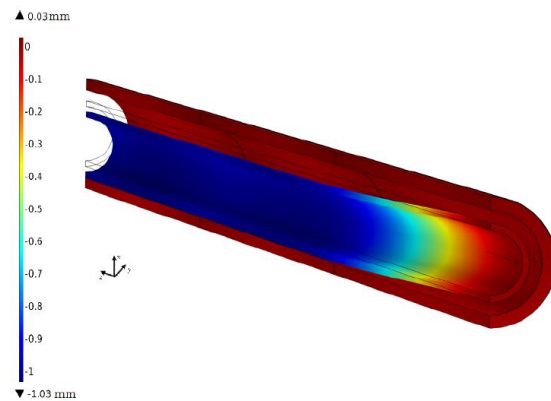

Figure 8 Vertical displacement of the outer and inner absorber tubes due to thermal stress.

Following the results of the numerical analysis, a prototype of the receiver and of the collector has been built.

3. Prototype of the collector and validation of the FEM model

The small parabolic trough collector realized has 1800 mm of length with a chord of about 420 mm (**Figure 9** and **Figure 10**). The parabolic mirror is made of aluminium and it has a rim angle of 110° . The realized receiver tube is made by two concentric copper ducts where the heat transfer fluid flows, letting the flow enter and exit just by one side. The absorber is surrounded by a glass envelope coated by AR layer. In order to reduce heat loss, the annulus between glass and copper tube is evacuated. The

absorber copper tube has a diameter of 10 mm (1 mm thickness), with a selective Cermet absorber ($\alpha=0.94$ and $\varepsilon=0.13$ at ambient temperature). A smaller tube is used with an internal diameter of 5 mm (0.5 mm thickness) to feed the receiver with a counter current fluid. Four springs support both the pipes in glass cylinder and keep them aligned in the reflector focus.



Figure 9 The small size parabolic collector.



Figure 10 The receiver tube.

A test bench has been designed to measure the heat loss of the receiver tube and it has been described in a previous work [9].

The experimental results of off-sun heat loss test have been compared with the outcome of numerical simulation in order to validate the FEM model. The numerical model predicted well heat losses at low temperature but underestimated heat losses at high temperature. The reason was that emissivity had been considered constant in simulations, whereas the emissivity of coating grows with temperature. Therefore, a model calibration has been necessary. The value of emissivity, at maximum temperature, has been varied until the numerical heat loss has been equal to experimental one. Knowing the emissivity value at ambient temperature and the value at 200°C, it is possible to approximate the variation of emissivity with temperature with a linear fit. **Figure 11** shows the comparison between the numerical and experimental results.

All numerical results lie in the experimental error bars. The numerical model is therefore validated.

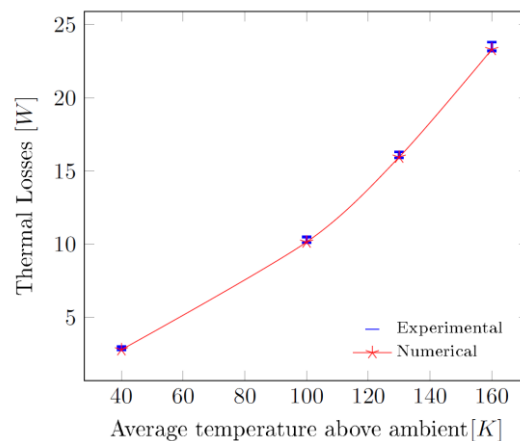

Figure 11 Comparison between experimental and numerical results.

4. Conclusions

A novel small parabolic trough, which can be easily installed on buildings roof, has been designed.

The optical design phase has allowed defining the main parameters of the optic components. The aperture of the parabola has been set to 500 mm in order to realize a compact collector suitable for residential application. The diameter of the absorber tube is 10 mm to intercept almost all the incoming radiation, keeping the concentration ratio high.

A FEM model has been realized in order to describe the heat transfer and the dynamic of the fluid inside the receiver tube. The solar flux obtained by ray tracing analysis has been imposed on the absorber

surface in the FEM model. The performances of the receiver tube have been investigated deeply through a parametric analysis. The selective coating chosen has emissivity of 0.15, a trade-off between low thermal losses and costs. The expected optical efficiency is 73%. The drop in thermal efficiency with temperature due to heat losses is 4% at 180°C.

A structural FEM model was also carried out in order to check if thermal stress could cause the removal of the absorber tube from the focus position. The predicted Von Mises stress are well below the yield stress and thanks to a proper number of constraints, the outer absorber tube remains in the initial position.

The prototype of the collector has been realized following the indications coming from the numerical models. The numerical analysis has allowed to design and fix the main features of the concentrating collector: aperture and rim angle of the parabola, diameter of the receiver tube, properties of materials involved in order to reach the target of performance, the optimal mass flow, etc.

Off sun test have been carried out on the prototype of the receiver tube. This has allowed to validate the FEM model. The dependency of emissivity with temperature has been obtained calibrating the FEM model. Since the numerical results were in good agreement with the experimental measurements, the FEM model has been validated through the experimental results of heat loss test.

The collector developed could offer a promising solution in order to reduce strongly the consumption of fossil fuels in buildings. Indeed, the small size parabolic collector possesses features that are intermediate between a standard parabolic trough collector and a solar thermal collector. It is characterized by high performances like a PTC (although it works at lower temperatures) but it is basically different from a PTC because of the reduced dimensions and consequently, more similar to a solar thermal collector.

The high thermal efficiency of the collector at 180°C allows producing heat for solar cooling via an absorption cycle or for power production via ORC cycle, overcoming the temperature limitations of solar thermal collectors. Therefore, the small size parabolic trough might lead the way towards trigeneration in buildings. Finally, supposing to integrate the small PTC with other technologies like thermal energy storage and solar PV collectors, it could be possible to convert the building into a positive energy building (PEB).

- [1] Economidou M, Atanasiu B, Despret C, Maio J, Nolte I and Rapf O 2011 Europe's buildings under the microscope A Country-by-country review of the energy performance of buildings *Building Performance Institute Europe (BPIE)*
- [2] Cheng Z D, He Y L, Xiao J, Tao Y B and Xu R J 2010 Three-dimensional numerical study of heat transfer characteristics in the receiver tube of parabolic trough solar collector *International Communications in Heat and Mass Transfer* **37**(7): 782-7
- [3] He Y L, Xiao J, Cheng Z D and Tao Y B 2011 A MCRT and FVM coupled simulation method for energy conversion process in parabolic trough solar collector *Renewable Energy* **36**(3) 976-985
- [4] Padilla R V, Demirkaya G, Goswami D Y, Stefanakos E and Rahman M M 2011 Heat transfer analysis of parabolic trough solar receiver *Applied Energy* **88** 5097-5110
- [5] Huang W, Hu P and Chen Z 2012 Performance simulation of a parabolic trough solar collector *Solar Energy* **86** 746-755
- [6] Cheng Z D, He Y L, Cui F Q, Xu R J, Tao Y B 2012 Numerical simulation of a parabolic trough solar collector with nonuniform solar flux conditions by coupling FVM and MCRT method *Solar Energy* **86**(6) 1770-84.
- [7] Hachicha A A, Rodríguez I, R. Capdevila R and Oliva 2013 A Heat transfer analysis and numerical simulation of a parabolic trough solar collector *Applied Energy* **111** 581-592
- [8] Wu Z, Li S, Yuan G, Lei D and Wang Z 2014 Three-dimensional numerical study of heat transfer characteristics of parabolic trough receiver *Applied Energy* **113** 902-911
- [9] Pierucci G, Hosouli S, Salvestroni M, Messeri M, Fagioli F, Taddei F and De Lucia M, 2017 Experimental methodology and thermal loss test on small size absorber tube for solar application *Energies* **11**(10) 2552