

THE LIBERTY WHEEL

Andrea BRACCIALI and Gianluca MEGNA

Department of Industrial Engineering, University of Florence, Italy
Via Santa Marta 3, 50139, Florence, Italy

Received: September 10, 2019

ABSTRACT

A new concept for tyred wheels is introduced in the paper, allowing cost reduction, mass reduction and shorter supply times. The project is based on a deep and critical review of the current practice in wheel maintenance and the current supply chain, finding and solving the criticalities that led to the current monopoly of monobloc wheels. It will be shown that the new tyred wheel, named *Liberty Wheel*, keeps its promises, allowing seamless rolling stock operation thanks to simple and inexpensive maintenance operations possible in nearly all current maintenance shops. It is a revolution for vehicles running up to at least 160 km/h without “strong” tread braking (trams, metros, light rail, commuter trains, regional trains, locos for freight trains, etc.)

Keywords: tyred wheels, tyres, machining, dovetail coupling, thermal stresses, ADI cast iron.

1. INTRODUCTION

1.1 Why *Liberty Wheels*?

Liberty means freedom in an even higher acceptation. Franklin D. Roosevelt, in the State of the Union Address to the Congress, January 6, 1941, proposed four fundamental freedoms that people "everywhere in the world" ought to enjoy: *Freedom of speech, Freedom of worship, Freedom from want, Freedom from fear.*

Such freedoms can not all and always be available in the purchasing process of wheels. Wheelset manufacturers managed to drive the market to monobloc wheels solution, claiming it's safer, cheaper, lighter, in a word “better”. This was embraced enthusiastically in a historical phase when many state-owned railway administration fell down or downsized dramatically. Outsourcing wheelset maintenance was often a no-alternatives decision, as internal workshops were closing, old workforce retiring and fixed costs reduction became an obsession.

Nowadays, almost all smaller railway enterprises sign “full service” contract with vehicle suppliers or, in the worst case, with external workshops to keep their wheelsets in good shape and to safely operate their fleets. Only larger railway enterprises still have their own “second level workshops”, where wheels are replaced, axles are machined and checked and so on.

We have forgotten that the two basic components of a wheelset – the axle and the wheels – are designed for *infinite life*, i.e. they do not fail if properly operated in service whatever long they serve under a vehicle. This statement falls like a house of cards when considering wheel tread wear.

Wheel tread wear is the inevitable result of the interaction between the wheel tread and the rail. Both wheels and rails suffer of many kinds of defects whose description lies outside the scope of this paper. However, due to flange wear, hollow tread wear or both the nominal wheel tread profile must be periodically restored machining it by means of underfloor lathe. This “reprofiling” process can be applied a limited number of times, until the wheel tread must be changed with a new one.

But, incidentally, tread is only a minor part of a monobloc wheel, that must be *entirely scrapped*, despite the fact that, as said, it was designed for infinite life. Moreover, the monobloc wheels replacing process may damage, and in many case *it damages*, the wheel seats, i.e. those portions of the axles that interface (with interference) with the wheels. As a consequence, axles need to be machined. After a few cycles, the axles need to be replaced, and this once again contradicts the assumption that axles should last forever.

All this nightmare, that makes wheelset manufacturers incredibly rich, was already existing before the “progress” of the last decades: the tyred wheel. Changing the (steel) tyres in a railway vehicle has the same effect of changing the (rubber) tyres in a car: the service may restart immediately without limitation. One could ask himself why tyred wheels went out of fashion: we’ll give our interpretation of the story, based on workshop practice, on workforce cost and on the distortion of a legislation that, at least in Europe, played a determinant role in forgetting what the founders of railways individuated as the best way to perform maintenance.

1.2 Technical and legislation reasons for tyred wheels death

Once all rail vehicles had tyred wheels. Since the braking was exclusively with blocks acting on the wheel tread, the only wear elements were, of course, brake blocks and wheel rims. There are steam locomotives and, subsequently, electric locomotives, which have been traveling for over 50 years without replacing the wheel centers and in many cases not even the axles, changing only the tyres.

Analyzing the reason of the rise of monobloc wheels, we must first mention the most serious problem of the tyred wheels, that is the risk of tyre loosening. This risk became certainty in the case of drag braking of freight wagons on long alpine descents, seriously affecting safety. From the 1960s onwards it was therefore understood that for freight traffic tyred wheels were unsuitable for guaranteeing the desired level of safety and monobloc wheels with low residual stresses, specific for the tread braking, began to develop.

The second reason for the gradual abandonment of the tyred wheels is to be found in European legislation. In 2002, in fact, the first Technical Specifications for Interoperability (TSIs) of the European High Speed system were published. As known, the TSIs are "supported" by the EN standards which must comply with the essential

requirements of the Railway Safety Directing. Dealing with high speed, tyred wheels were considered as centrifugal actions at 300 km/h may loosen the tyres. When the TSIs for the "conventional railway" were published in 2007, the regulator "forgot" to re-consider tyred wheels. It is worth to remember that participation in standardization groups is voluntary and unpaid, and that no producer of railway wheels (obviously monobloc) had any interest in reintroducing a solution that made them earn less.

But the third and final reason is linked to maintenance costs and will be discussed in the paper.

2. THE DESIGN OF TYRED WHEELS: SHRINK FIT STRESSES

Recent literature on the design of tyred wheels is simply non-existent. One of the few references providing information on stresses and strains in the wheel centre and in the wheel tyre is the old book by K. Sachs, "Elektrische Triebfahrzeuge", published in 1973. A sketch comparing monobloc and tyred wheels is shown for convenience in Figure 1.

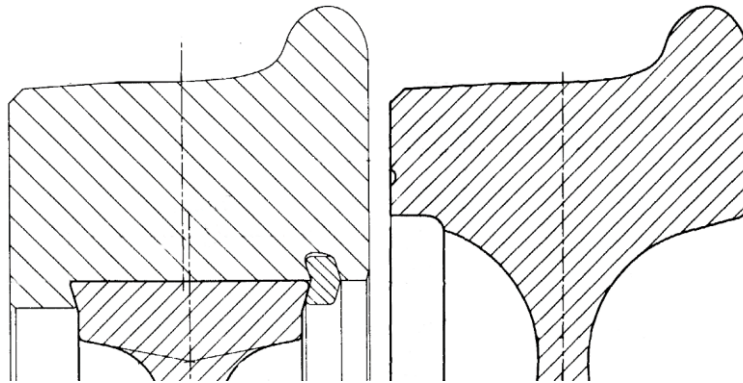

Fig. 1 Drawings of a tyred (420 kg, left) and monobloc (340 kg, right) wheel with the same external diameter of 940 mm. Tyres are fitted with a typical interference of 1.3‰ of the coupling diameter in mm.

We observed that almost all wheel centres had "curves" in the cross-section. Apparently, this was due to the need of ensuring some radial elasticity to compensate for the expansion and the contraction of the tyre during long drag brakings.

We developed a FEM model able to predict what happens when a tyre is applied by shrink fitting to four different types of wheel centre considering also the wheel centre fitting on the axle and we published the results in paper [1]. The original results from prof. Sachs's book that we used as a reference are shown in Figure 2. During the analyses, it readily emerged that in most cases the elastic limit of the material in the wheel centre is exceeded. A purely linear model of the material behaviour is therefore not sufficient and an ideal elasto-plastic material model was used. Resulting von Mises stresses from our simulations are shown in Figure 3.

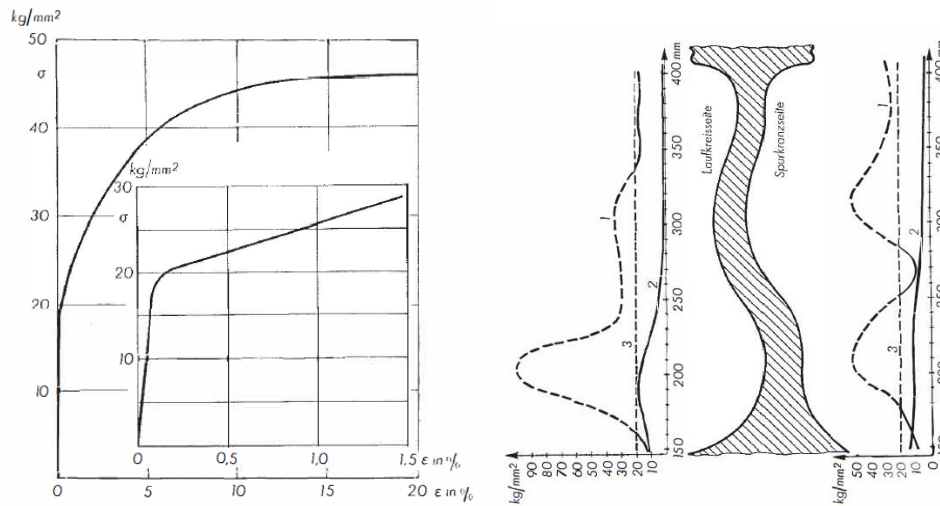

Fig. 2 Left: tensile strength curve for the wheel centre steel, with a focus on the yield point. Right: comparison of the von Mises equivalent stresses with the yield stress (3), for the axle + tyre fitting (1) and for the axle fitting only (2).

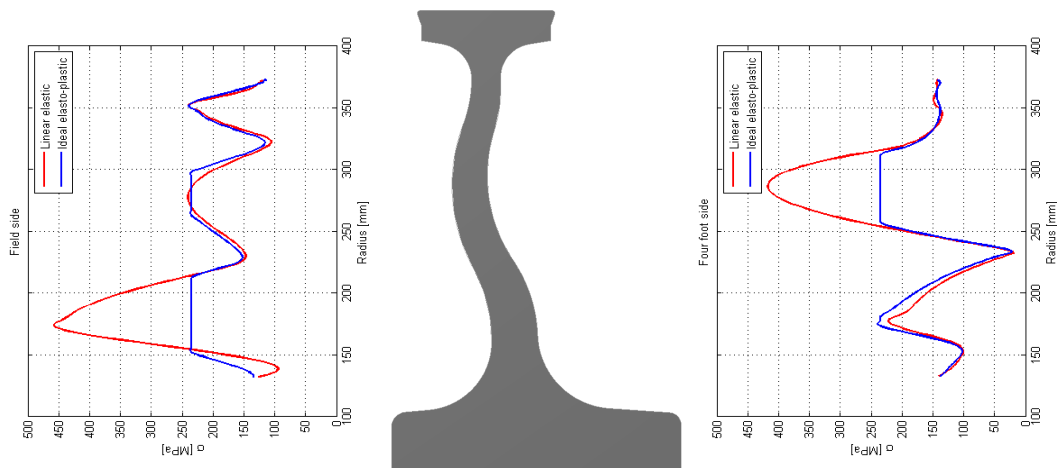

Fig. 3 von Mises stresses for a linear elastic material model and an ideal elasto-plastic material model.

Plastic strains can not be neglected and can bring to permanent shape modifications in the wheel centre geometry and may influence wheelset geometric tolerances. We learned therefore that the design of older wheel centre was probably performed before the computer era on the basis of (unknown) empirical calculations. We found in fact large variations in the radial stiffness (from 56 to 119 MPa/mm applying 1 MPa on the mating surface of linear models representing the four wheels analysed) and this means that a guideline or a general design rule was missing.

We discovered moreover that the pressure at the tyre/wheel centre interface was extremely variable, in one case from around 70 MPa just over the wheel web to around 28 at the ends of the contact (Figure 4). This looks like a design mistake, but we should never forget that in the XIX Century there were no the sophisticated resources that are available today.

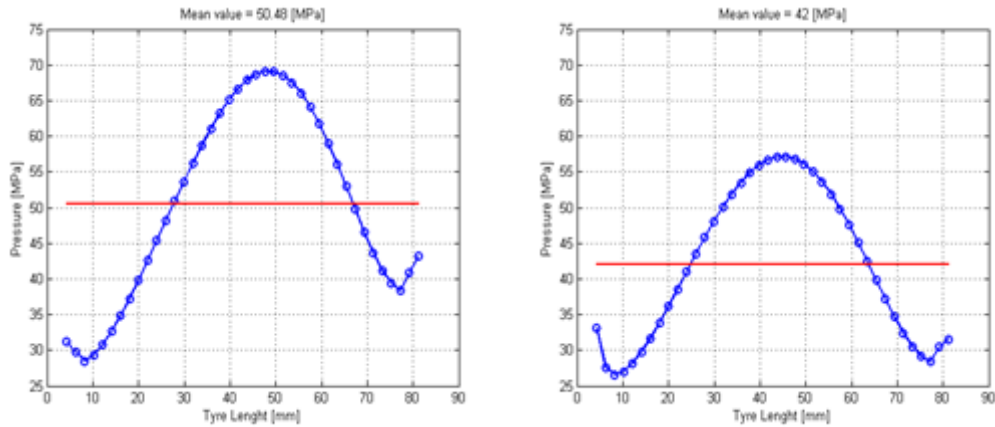

Fig. 4 Pressure at the wheel/tyre interface with the maximum interference and new tyre for two different axisymmetric wheels.

Thanks to the experience gained with these simulations, we are now able to analyse any existing wheel centre and evaluate its elasto-plastic behaviour, its radial stiffness and, even more important, lateral deviations arising from the tyre cooling process that may impair the correct geometry (Figure 5). The application of the *Liberty Wheel* concept to existing wheel centre passes inevitably through this crucial phase that must be conducted carefully.

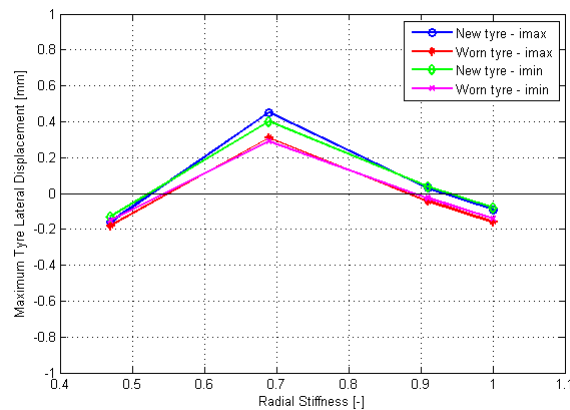

Fig. 5 Lateral displacement of the tyre after the shrink fitting as a function of radial stiffness (normalized to the stiffest wheel = 119 MPa/mm).

3. THE DESIGN OF TYRED WHEELS: IS TYRE THICKNESS CORRECT?

New tyre thickness is normally 70÷75 mm and the worn thickness is 35÷40 mm. This is due to the need of transmitting the maximum torque in all braking (hot) conditions also in fully worn conditions. As a consequence, tyred wheels are much heavier than monobloc wheels.

It should be remembered that the inequacy of tired wheels to withstand drag braking was investigated and clarified in the '60s of the last century. As an example (see [2] for more details), tyres can be considered as “loosened” after a 15 minutes brake with a tread braking power of 20 kW, values that are much lower than those required by the standards simulating the Gotthard line slope. As a result, freight wagons are going to be equipped by 2020 only with monobloc wheels.

If the thermal input is largely decreased, as in modern EMU that use tread braking only marginally, or completely eliminated, as in all vehicles braked with brake discs, the tyre-wheel centre pressure needed is lower.

We performed a thorough analysis, published in [2], where we compared the torque transmitted at the wheel-rail contact (and therefore at the tyre-wheel centre interface) for light DMUs, a 20 t/axle diesel locomotive, a 17.2 t/axle electric locomotive and a 21 t/axle locomotive with different wheel and transmission arrangements, considering a maximum wheel-rail friction coefficient of $\mu=0.8$. Also self-excited vibrations of kinematic transmission chain and traction motor short circuits were considered. A suitable model was set up and we found the the average pressure needed at the tyre-wheel centre interface was, in the worst case, lower than 1 MPa.

As we said before that the pressure at the tyre-wheel centre interface ranges from 25 MPa to nearly 70 MPa, it is evident that there are large margins of improvement to reduce tyre thickness and/or interference. Without any thermal input, in fact, the torque transmissible by the current (old) tired wheels is more than ten times the traction motor short circuit situation.

We have developed all the tools needed to evaluate local slip that may happen at the tyre-wheel centre coupling in case the pressure is reduced. This analysis is central to avoid the appearance of a classical and certainly undesired phenomenon potentially present in interference fit couplings, i.e. *fretting corrosion*.

Figure 6 gives an example of the degree of detail and accuracy that we have reached in simulating the combined effect of preload (tyre shrink fit), applied torque and applied vertical load.

Referring to the title of this chapter, we can say that the tyre thickness used in the past for heavily-tread braked vehicle is not correct, being too large. We can investigate the effect on pressure, loosening and fretting phenomena on vehicles of any kind, reducing the mass of existing tyres by nearly 50%.

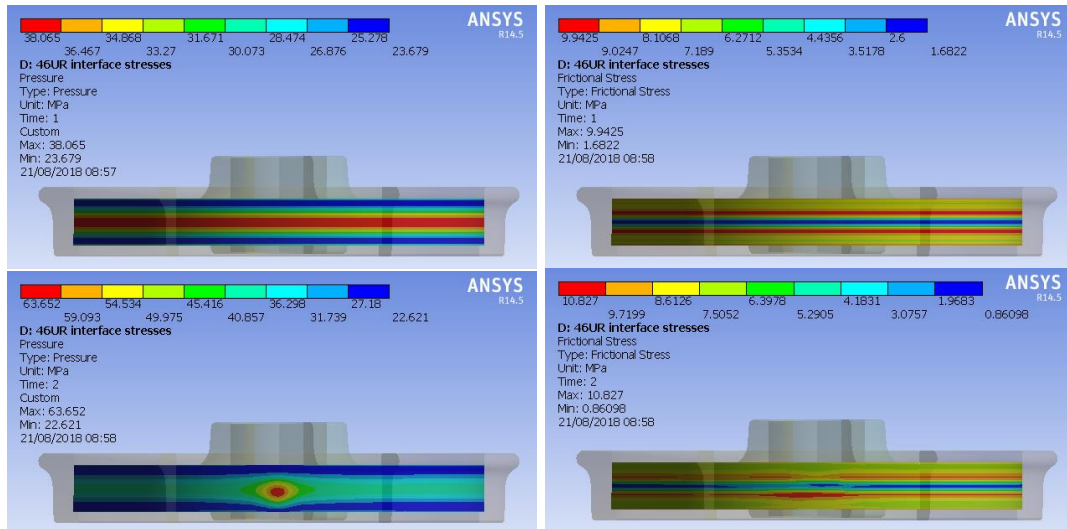

Fig. 6 Top: pressure at the wheel centre-tyre interface (left) and frictional stresses (right) for $\mu_{tw} = 0.3$ for a freight wagon wheel with the tyre fitted at maximum interference (1.106 mm). Bottom: the same with vertical load (100 kN) and maximum torque (14795 Nm)..

4. TYRED WHEELS MAINTENANCE: ANALYSIS AND IMPROVEMENTS

Tyred wheels were not abandoned for mass reasons or for thermal reasons. There are in fact a number of applications in which they are undoubtedly winners vs. monobloc wheels. The main reason was the completely wrong maintenance cycle.

In the “worst case”, the following operations are traditionally performed, starting from the wheelset already removed from the bogie:

1. the wheelset is moved to a “wheelset lathe” where the retaining rings are machined and removed;
2. the wheelset is moved to the tyre cutting station, typically an alternating saw one;
3. the wheelset is moved to the tyre removal station, where the (nearly fully) cut tyres are pulled away from the wheel centre;
4. the wheelset is moved to the “wheelset lathe” where the wheel centres are machined to a new (smaller) diameter;
5. new tyres are moved to a vertical lathe and machined to the matching diameter to ensure the right interference;
6. new tyres are moved to the heating station;
7. both hot tyres and the wheelset are moved to the assembly station, where they are assembled with a manual procedure (“upside down”);
8. retaining rings are installed manually;
9. after cooling, the completed wheelset is moved to a “wheelset lathe” where the wheels are reprofiled to the wanted profile and dimensions.

We discovered that different operators apply this sequence differently, proving that each operator works independently and that in the last decades there has not been any exchange of information among operators using tired wheels.

There is no need to be top ranking economists to realize that this maintenance procedure totally vanishes any advantage of tired wheels, as the maintenance cycle of a monobloc wheel (machining of the bore and press-fit) easily wins the competition.

We believe that the weakest points of the traditional mounting procedure are related to the presence of the retaining ring and the fact that the tyre bore diameter is adjusted every time on the wheel centre diameter after its machining, often needed as tyre removal damages the wheel centre mating surface.

Both the limitations were removed by recalling one of the basic principles of mechanics, i.e. interchangeability of components thanks to proper tolerancing. We initially thought about a “dovetail coupling”, removing the need for the retaining ring, once structural calculations proved that the coupling is safe (Figure 7).

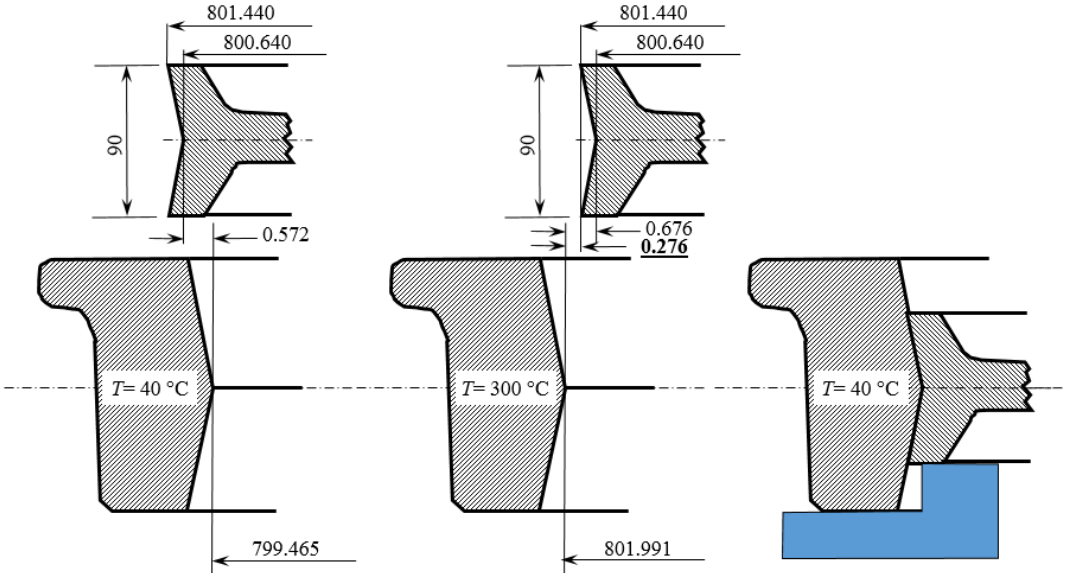
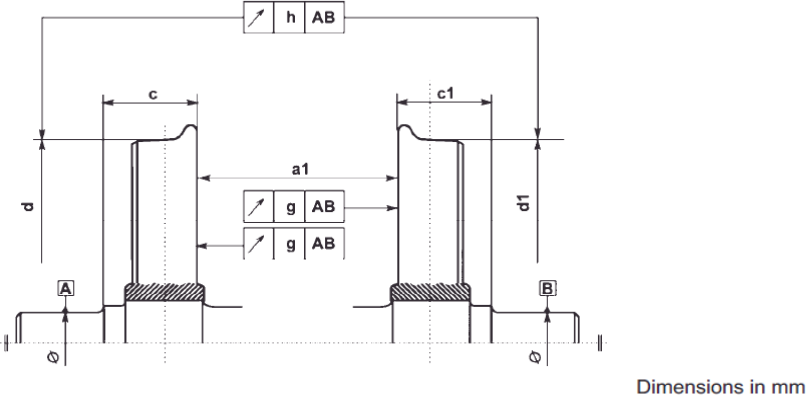

Fig. 7 Relative position of coaxial wheel centre and tyre with 800 t7/S8 coupling in cold (right) and hot (centre) conditions. A sufficient radial play for mounting of 0.276 mm is obtained even with the maximum radial interference of 0.572 mm. Right: simple tool to guarantee the respect of geometrical tolerances after fitting (from [3]).

This solution appeared to be easy to machine and positively affecting the maintenance cycle. With this new technology, in fact, all was needed is a device to remove the tyre by heat without damaging the wheel centre (e.g. with an induction heater or propane burners) and a similar device to heat the new tyre up before installation.

The entire process makes sense only if fully machined tyres can be installed on machined wheel centres without needing any machine tool (e.g. the “wheelset lathe”) and if both radial and lateral run-outs of the assembled wheelset with new tyres remain within the tolerances prescribed by the International Standards after assembly (Figure 8).



Description	Symbol	Category 2		Category 1
		a	b	
Distance between the internal wheel faces ^a	a_1	+2 ^b 0		+2 ^b 0
Difference in distances between the internal face of each wheel and the plane on the journal side defining the corresponding collar bearing surface	$c - c_1$ or $c_1 - c$	≤ 1		≤ 1
Difference in tread circle diameter	$d - d_1$ or $d_1 - d$	≤ 0,5	≤ 0,3	≤ 0,3
Radial run-out in tread circle	h	≤ 0,5	≤ 0,3	≤ 0,3
Axial run-out of the internal wheel face ^a	g	≤ 0,8	≤ 0,5	≤ 0,3

^a Measurement at 60 mm beneath the top of the flange
^b The tolerances may be changed for special designs of wheelsets

Fig. 8 Tolerances and maximum errors after wheelset mounting (excerpt from EN 13260).

Extensive workshop activities were performed eventually leading to line tests on a DMU vehicle in November 2018 (Figure 9). The results were fully positive and all the expected targets were achieved. It must be said that the original dovetail coupling was modified to bring the contact of mating surfaces in the area where the wheel centre is stiffer. For further details the reader is referred to [7].

About safety, Common Safety Methods defined by European Union Regulation 402/2013 applies in this context because the evaluation of the impact on safety is obviously applicable to wheelsets. In general, if the proposed modification is considered “not significant” on the basis of a set of well defined criteria, “keeping adequate documentation to justify the decision shall be sufficient”.

The application of CSM to the present case looks straightforward and painless. Removal of safety conditions based on friction (use of mechanical abutments), elimination of tread braking (no tyre loosening possible) and correct machining and

mounting procedures are sufficient to implement the modification without any real impact on safety, which results improved by the our design.

Summarizing, we defined and tested a new (and safer) approach to tyre changing that can be performed in any workshop, even the most remote, as it does not involve machine tools or any other specific “complex” operation. The wheelset maintenance cycle simplifies dramatically and it consists only in tyre removal by heat, cleaning of the surface, installation of a new (fully machined) hot tyre and tyre cool down. Our design proved to be simple, easy to machine and even easier to apply.

Thanks to this experience, we can implement the process (including the tools) in any practical situation involving tyred wheels.



Fig. 9 Left: lowering a trailed wheelset on a hot tyre resting on the specifically designed mounting jig with calibrated shims. Right: the ALn668.1036 vehicle before the tests on the roundtable in Iseo, Italy, 21st November 2018.

5. THE *LIBERTY WHEEL* TAKES SHAPE

5.1 Development of the idea and material selection

When discussing with potential customers we realized that what was needed is not only a way to improve maintenance but a comprehensive approach to tyred wheels in general.

As we have shown above, wheel centres are old and poorly designed, tyre thickness is wrong, maintenance operations are a nightmare. Tyre-wheel centre pressure was badly distributed, the retaining ring is a source of further problems, mass is too high.

There was, clearly, the need to rethink from the start to a modern, light, well designed, reliable and low cost tyred wheel.

We collected all the experience gained in the aforementioned studies and we decided to develop a brand new concept for a tyred wheel that we named *Liberty Wheel* for reasons that will be clear soon.

First of all we opted for a larger and (radially) stiffer area on the wheel centre in order to better distribute pressure on the tyre-wheel centre surface and to increase the safety linked to potential lateral movements of the tyre. We soon realized that one web was not sufficient to achieve such goal, then we were forced to abandon the classical forged and rolled wheel centre.

Having to make recourse to a casted solution, we discarded soon the steel option as an interesting alternative appeared at the horizon: “modern” cast iron. Cast iron has fantastic pouring characteristics (“*cast irons are nature’s gift to foundrymen*”) but is traditionally considered brittle and with generally low mechanical properties, much lower than those of cast steel.

This frame changed completely in the ‘70s, when technologies to produce spheroidal graphite cast iron (developed in 1943) and austempering thermal treatment (known since the ‘30s) were first combined to get the first Austempered Ductile Iron (ADI). One of the most complete description of the ADI cast iron says:

What material offers the design engineer the best combination of low cost, design flexibility, good machinability, high strength-to-weight ratio and good toughness, wear resistance and fatigue strength? Austempered Ductile Iron (ADI) may be the answer to that question. ADI offers this superior combination of properties because it can be cast like any other member of the Ductile Iron family, thus offering all the production advantages of a conventional Ductile Iron casting. Subsequently it is subjected to the austempering process to produce mechanical properties that are superior to conventional ductile iron, cast and forged aluminum and many cast and forged steels. (from <https://www.ductile.org/didata/Section4/4intro.htm>).

The description of mechanical properties of the ADI grade we decided to use (ADI 800 according to ISO 17804, EN 1564 and ASTM A897) lies outside of the scope of this paper, but we can simply say that it competes with quenched and tempered alloyed steels such as 42CrMo4, showing therefore extremely interesting mechanical properties.

While the use of ADI is not new in the railway wheels field, quite recently Siemens developed a monobloc wheel made of this material (see K. Strommer, F.J. Weber, *Austempered Ductile Iron Spoke Wheel*, Proceedings of the XIX International Wheelset Congress, Venice, 16-20 giugno 2019) within the frame of a Shift2Rail European project. As the wheels interface with the rails, for clear compatibility reasons this wheel will be tested only in a metro, in which the consequences of RCF and wear problems are lower than on a conventional rail network. We discarded this option from the beginning, as a monobloc wheel, even if made of ADI, has the intrinsic limitation of a “disposable” product when the tyre is worn, which goes against the philosophy of our project.

We decided therefore to design a wheel centre with two spoked webs and a conventional steel tyre, opening the applicability to all vehicles running in the “conventional rail” environment. ADI was perfect: easy to purchase from a large number of suppliers and castable in nearly every shape without big headaches from the quality point of view.

The absence (or the strong reduction of thermal inputs) led to non-necessity of undulated webs. Spokes were therefore conceived straight and nearly parallel for the specific vehicle, that was a DMU with 12 tonnes axleload. We started the FEM development of the wheel centre keeping the alternate stress very low (± 89 MPa) under the loads described by the EN 13979 standard to take into account typical surface foundry defects. After some iterations, we were able to design a wheel centre easily castable and 50 kg lighter than the original one (Figure 10).

We also change the drawing of the tyre-wheel tread positive coupling. The surface became in fact a single taper (1:75) with a small abutment. This change was suggested by the the workshop as the presence of the abutment allows mounting with the axis horizontal, while its absence forces the mounting only with the axis vertical (Figure 10).

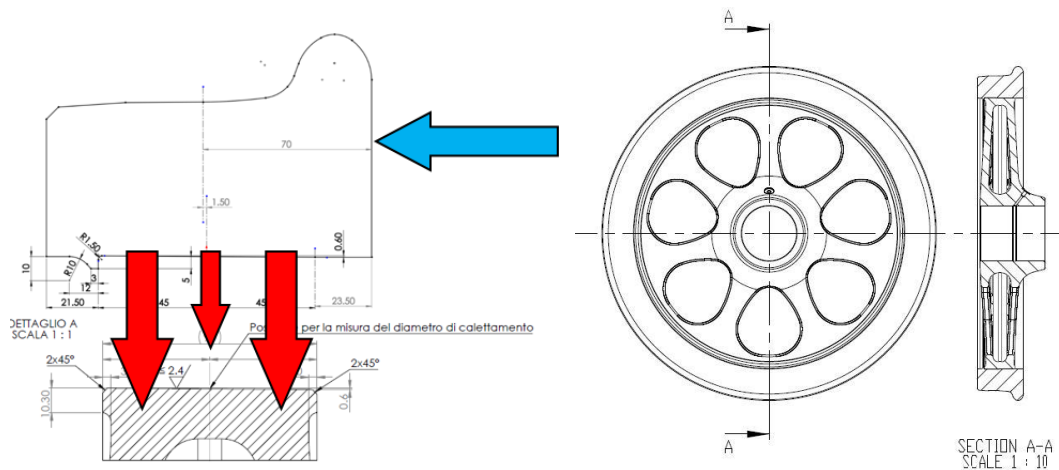

Figure 10 Left: reaction to a lateral force distributed on the two rank of spokes of the *Liberty Wheel*. Right: final drawing of the *Liberty Wheel* with the tyre installed.

5.2 *Liberty Wheel* manufacturing and testing

The selected foundry performed castability validation (pouring, solidification, voids, etc.) starting from 3-D CAD drawings, preparing also models and moulds. First wheel centres were casted on 31.01.2019 (Figure 11, Figure 12).

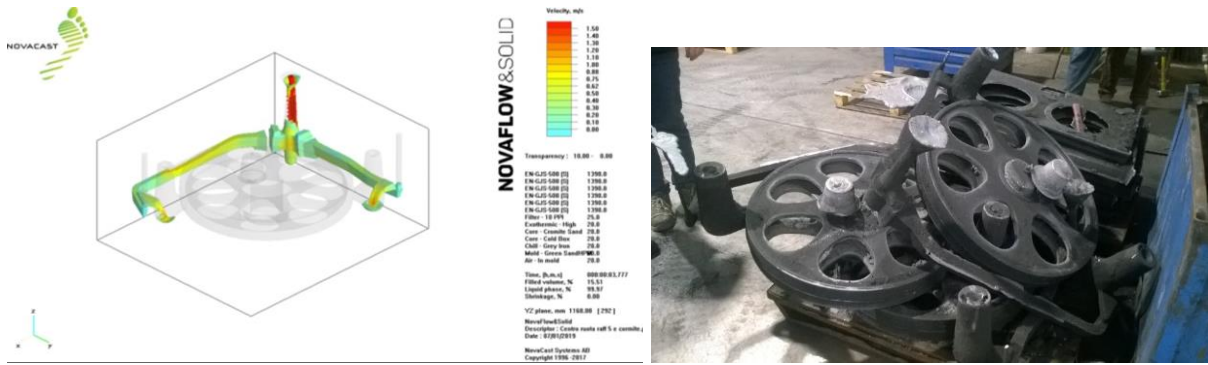

Figure 11 Left: simulation of velocity during liquid cast iron pouring. Right: the first three *Liberty Wheels* (31.01.2019) before feeders are cut off.



Figure 12 The first *Liberty Wheel* cut to get samples for mechanical properties tests (31.01.2019).

The first wheel centre was RT, while all wheel centres were UT 100%. After sand blasting, castings were heat treated, sand blasted again and machined (Figure 13, Figure 14). It is worth reporting that all the wheelsets assembled from machined wheels resulted to be naturally balanced (<75 gm), making the wheelset suitable for operation up to 200 km/h.



Figure 13. Left: first mounting on an axle. Mid: CMM dimensional check. Right: first *Liberty Wheel* assembly with the tyre.



Figure 14 Top: the very first wheelset with *Liberty Wheels* (16.04.2019). Bottom: comparison of the *Liberty Wheel* with the original wheel centre

A *Liberty Wheel* was tested on a full-scale test bench (Figure 15). Stresses in the spokes were first measured during tyre installation, then a 10^6 cycles test was performed with an alternate stress of ± 300 MPa without any failure. This result was possible thanks to the pre-stress (compression) of the spokes such that they never go in the positive (tension) field. Cracks cannot therefore propagate. More detailed information on stress analysis can be found in [6].



Figure 15 Measuring the strains in the spokes by means of ER strain gauges during cooling of the tyre (left). The *Liberty Wheel* under test mounted in the full-scale facility (right).

5.3 Line tests with the *Liberty Wheels*

A complete set of wheelset for the selected DMU was tested in May 2019, making sure that the two bogies (one equipped with *Liberty Wheels*) and the other one with the original solution have the same tread roughness to get valid noise data during the pass-by measurements (Figure 16). Noise measurements, including all needed ancillary measurements (rail roughness, wheel roughness, track decay rate) are not reported here for brevity. Noise of the *Liberty Wheels* was more than 1.5 dB lower than the original wheels.



Figure 16. *Liberty wheels* tested on the DMU vehicle ALn668.1053 (14.05.2019, Iseo, Brescia, Italy).

5. CONCLUSIONS

For a number of reasons, discussed in the paper, tired wheels nearly disappeared from the railway world. We have seen how the maintenance cycle of a wheelset with tired wheels was the most important reason for the decay of this product.

Tyred wheels maintenance requires at least one standard machine tool (a front lathe or a medium-sized vertical lathe) and often a special machine tool (a "wheelset lathe"). Machine tools are complex, require highly specialized workers and are large, heavy

and expensive. This implies that maintenance of existing tyred wheels cannot be performed in any workshop but only in some specialized centers.

One might wonder why tyred wheels did not benefit from any technological progress. The market analysis easily explains this "lack of updating":

- no modern vehicle is equipped with tyred wheels, so maintenance cycles, submitted to the competent bodies for approval, were optimized only for the monobloc wheels;
- having neither development nor future, and with increasingly smaller fleets destined to local or secondary services, railway enterprises did not invest in either training of personnel or equipment / machinery, risking in some cases the paradox of stopping vehicles because "the good old mechanical turner" retired;
- neither the national regulatory bodies, always less influential, nor European standardization bodies ever considered tyred wheels, thus lacking a regulatory support that may also address maintenance practices;
- the various "historic" railway administrations, which have by now almost disappeared as a result of EU directives, stopped issuing "standards" in the field of wheelsets, so the only rules that can be found today on the maintenance of tyred wheels are never updated 20 or 30 years old "technical instructions" (and after all it would have made no sense).

As a result, the few workshops that today maintain tyred wheels are often characterized by manual machine tools, highly-skilled staff, manual measuring instruments and very low productivity. They offer repair a mix of very different wheels, making the slightest automation of the maintenance process simply impossible. Wheelsets often arrive in "desperate" conditions resulting from a decades-long operation that makes them completely different from their design standards. In short, tyred wheels maintenance shops look more like a tailor-made atelier than an industrial process.

A quite simple idea – the introduction of the *dovetail coupling*, i.e. the replacement of the conventional cylindrical tyre/wheel centre mating with a positive coupling removing at the same time the retaining ring – triggered a deeper reconsideration on the future of tyred wheels. Although the absence of literature, and on the basis of just a few sources of data, the design of the wheel centres, of the tyres were criticized and a deep review of the maintenance process was performed.

We realized that what was perfect for our predecessors, in a world in which labour costs were affordable and time had a different value, became unacceptable to modern railways. What was good in the concept of tyred wheels was therefore discarded and wasted in favour of monobloc wheels, a solution with *apparently* shorter overhaul times and lower costs.

With this work, we have demonstrated that tyred wheels may have a future again. The possibility of changing the tyres nearly everywhere and in real time opens new possibilities to railway enterprises operating certain classes of vehicles. But we understood that modifying an existing wheel was not enough: customers may need a complete solution with a shorter supply chain, involving new actors, saving considerable time and money. That's we we developed the *Liberty Wheel*.

The *Liberty Wheel* is not just a design: it is a product. We designed it, we manufactured it, we tested it. It is a low cost way to be free of the current market necklace, unleashing the possibility of purchasing tyred wheels at a fraction of monobloc wheels and, even more important, to perform *real time maintenance* nearly for free. So, whatever you trust in, you should not fear asking for new wheels in reasonable time, at reasonable cost, with your own design and without fearing the possibility of the lack of a "plan B" in case relationships with wheelset manufacturers go wrong for whatever reason.

This paper described how we developed the *Liberty Wheel*, what we did, what we did not (and why), what we got and what you can get if you believe in this new (old!) technology.

6. REFERENCES

- [1] **BRACCIALI, A. and MEGNA, G.:** Stresses and strains in tyred wheels during tyre fitting process, Proceedings of The Fourth International Conference on Railway Technolgy, Railways 2018, 3-7 September 2018, Sitges, Barcelona, Spain.
- [2] **BRACCIALI, A. and MEGNA, G.:** Tyred wheels without braking: structural optimization, Proceedings of The Fourth International Conference on Railway Technolgy, Railways 2018, 3-7 September 2018, Sitges, Barcelona, Spain.
- [3] **BRACCIALI, A. and MEGNA, G.:** Re-design of tyred wheels to optimize maintenance, Proceedings of The Fourth International Conference on Railway Technolgy, Railways 2018, 3-7 September 2018, Sitges, Barcelona, Spain.
- [4] **BRACCIALI, A., CAIANIELLO, G., CAIANIELLO, G. and MEGNA, G.:** Moderni sviluppi nella manutenzione delle sale ferroviarie, in Atti dell'8° Convegno Nazionale sul Sistema TRAM, Roma, Italy, May 29-30, 2019 (in Italian).
- [5] **BOCCIOLINI, L., BOVÌ, R., BRACCIALI, A., CAIANIELLO, G., MEGNA, G., ROTA, L., TEMPORIN, E. and VENERI, E.:** Manufacturing and testing of a tyred wheel with casted ADI wheel centre, Proceedings of the XIX International Wheelset Congress, Venice, Italy, June 16-20, 2019.
- [6] **BRACCIALI, A., MASAGGIA, S., MEGNA, G. and VENERI, E.:** Quiet and light spoked wheel centres made of Austempered Ductile Iron, Proceedings of the XIX International Wheelset Congress, Venice, Italy, June 16-20, 2019.

- [7] **BRACCIALI, A., CAIANIELLO, G., MEGNA, G., PETRESCHI, P. and ROTA, L.:** Dovetail Tyred Wheels – Application to a DMU, Proceedings of the XIX International Wheelset Congress, Venice, Italy, June 16-20, 2019.