

# Manufacturing and testing of a tyred wheel with casted ADI wheel centre

Luca BOCCIOLINI<sup>1</sup>, Riccardo BOVI<sup>2</sup>, Andrea BRACCIALI<sup>3</sup>, Giorgio CAIANIELLO<sup>4</sup>, Gianluca MEGNA<sup>3</sup>, Lucio ROTA<sup>5</sup>, Elia TEMPORIN<sup>6</sup>, Enrico VENERI<sup>7</sup>

<sup>1</sup>ITALCERTIFER SpA, Florence, Italy

<sup>2</sup>RFI Ricerca e Sviluppo, Florence, Italy

<sup>3</sup>Department of Industrial Engineering, Università di Firenze, Florence, Italy

<sup>4</sup>Nuova Comafer s.r.l., Caivano, Naples, Italy

<sup>5</sup>TRENORD s.r.l., Milan, Italy

<sup>6</sup>Fonderia Baraldi Silvano srl, Montagnana, Padova, Italy

<sup>7</sup>Zanardi Fonderie S.p.A., Minerbe, Verona, Italy

[andrea.bracciali@unifi.it](mailto:andrea.bracciali@unifi.it)

## Abstract:

Although the foundry practice of cast iron is well established, manufacturing a wheel with this material requires a careful choice of casting parameters in order to produce defect-free castings suitable for the assembly of a railway wheelset. In this paper, both the manufacturing and the testing phases of an innovative wheel centre made of Austempered Cast Iron (ADI) are described. The full qualification of a new wheel requires a long testing process, whose fundamental steps are the assessment of the material properties and of the fatigue resistance of the wheel. The papers discusses also other properties measured during testing, such as the vibration (damping) behaviour of the wheel centre as well as complete noise characterization including line tests

**Keywords:** Casted wheel centre, full scale testing, fatigue validation, Austempered Ductile Iron

## 1. INTRODUCTION

In the frame of the activities for the development of a lightweight and quiet wheel centre for the class ALn668 DMU belonging to the fleet of the railway enterprise TRENORD, the use of Austempered Ductile Iron (ADI) castings was considered. Structural design strength and numerical validation of the wheel centre are shown in another paper give to this conference [1]. Fundamental part of the project was the development of a dovetail (tapered) tyre / wheel centre coupling in order to avoid the use of the retaining ring while keeping safety margins of the traditional (and very expensive from a maintenance point of view) solution [2].

Manufacturing a wheel requires a strong control on all phases, from iron composition to casting, from visual tests to RT and UT tests. The paper describes manufacturing, destructive and non-destructive testing with the relevant results.

This paper reports on the comprehensive testing plan, to achieve a complete analysis of the in-service behaviour of a vehicle equipped with casted ADI wheel centres.

As it is clear that safety plays the most important role in service, material testing and full-scale testing of a wheel centre will be described first.

Nevertheless, other properties of the wheel centres and of the vehicle will be assessed, namely the vibroacoustic properties of the wheel centre obtained with laboratory tests and noise emissions measured during pass-by tests of a vehicle equipped of this innovative solution.

The new wheel centre (130 kg) allows a mass reduction of 50 kg with respect to the original steel wheel centre (180 kg).

## 2. THE MANUFACTURING PROCESS

### 2.1. Casting process

The material used in this project is ADI800-10 according to [3]. It is basically a spheroidal graphite cast iron with a specific formulation developed by Zanardi Fonderie SpA in order to get the best combination of mechanical properties.

The particular shape of the new wheel centre with two ranks of spokes is obtainable only thanks the high castability properties of cast iron (see e.g. [4], p. 315). Fonderia Silvano Baraldi took care of the computer aided design of the mould. Very good quality castings were reached without internal porosity, which is common instead in steel castings.

The upper and the lower part of the sand mould were created after the production of a split wooden model, and then the final “negative” shape is obtained inserting one chromite core for the hub hole and a polymerized sand core for the internal cavity between the spokes. Chillers are properly inserted in the mould in order to drive the solidification. After cooling, castings were removed from the mould and sand blasted.

Twelve wheel centres were manufactured in two batches (3+9), with only one scrap piece (sand dragging) and one used untreated for acoustical tests. The remaining 10 wheel centres were austempered; one was preliminarily cut to get samples for destructive tests and 9 were machined. Four of this last group of wheels were later installed on a vehicle; a fifth wheel centre was used to perform full scale fatigue tests.

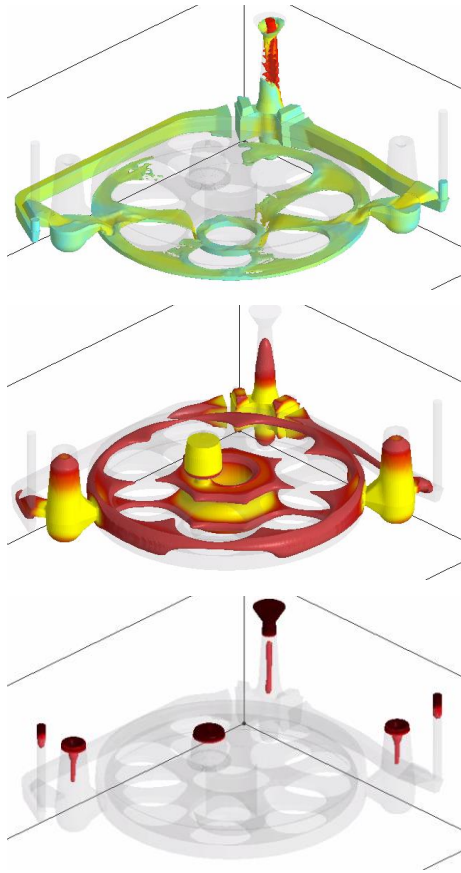

Fig. 1 Velocity (top), solidification (mid) and shrinkage (bottom) of cast iron as simulated by Fonderia Silvano Baraldi.

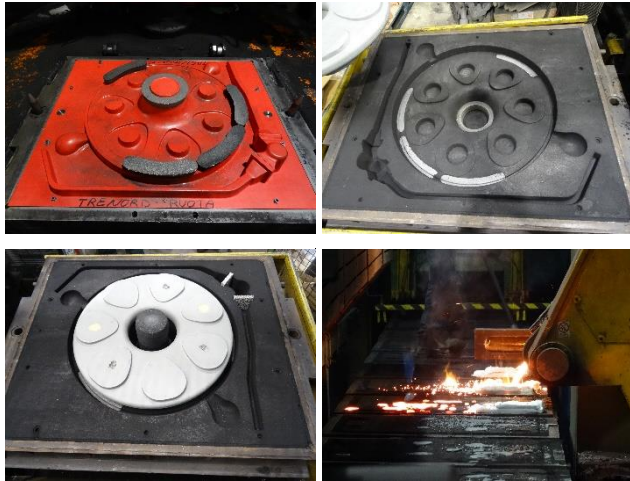

Fig. 2 Different stages of casting process. Top left: lower side of the wooden model (with chillers). Top right: the mating "negative" sand mould. Bottom left: the same with inserted cores. Bottom right: pouring molten cast iron inside the mould.

## 2.2. Non-destructive tests

All wheels were visually checked after sand blasting. One wheel in the batch was radiographed according to ASME B16.34-2017 (RT 100% full coverage). The casting resulted conforming to acceptance criteria ASTM E446 level 3. One-hundred percent of the wheels were UT tested according to EN 12680-3 and resulted conforming to acceptance criteria CL.3.



Fig. 3 Final casting after sanding (left) and cut wheel centre to obtain specimens for destructive tests (right).

## 2.3. Austempering process

The austempering process is a massive heat treatment applied to conventional spheroidal cast iron in order to reach better mechanical properties [1] in terms of strength and ductility. It consists in heating the entire component over the austenitization temperature and then cooling it rapidly down to a temperature defined as the "austempering temperature" (usually in the range  $300 \div 400$  °C). Then, this temperature is hold for a sufficiently long time to reach a microstructure consisting of acicular ferrite and retained austenite. Zanardi Fonderie S.p.A. is a leader in Italy for such treatment. Nine wheels plus the slices obtained from cutting the first wheel were treated.

## 2.4. Results of the mechanical tests

Tensile stresses, elongation, and hardness were tested on samples according to EN ISO 6892-1:2009 (tensile) and EN ISO 6506-1:2014 (hardness). All values were largely in excess of the minimum values requested by the standard [3]. Elongations are particularly high compared to spheroidal cast iron with similar tensile strength (TABLE I. ).

TABLE I. MECHANICAL PROPERTIES OF SAMPLES TAKEN FROM THE FIRST AUSTEMPERED WHEEL CENTRE

Part	Reference thickness [mm]	R <sub>m</sub> [MPa]	R <sub>p0.2</sub> [MPa]	A <sub>5%</sub>	HBW
Hub	30 ÷ 60	821	598	5.8	292
Spoke	< 30	951	654	10.8	298
Rim	< 30	918	617	11.0	285
Hub face	-	-	-	-	296
Specimen casted apart	< 30	997	674	12.7	292

## 2.5. Machining

Machining of the wheel centres is described in [2] and it is not detailed further. It is only worth noting that all the wheels were machined and the wheelsets for the tests described below were assembled respecting geometric and unbalancing tolerances without problems.

## 3. FULL SCALE FATIGUE TESTS

### 3.1. The fatigue test bench

Full scale wheel fatigue tests are used as a method for the assessment of material mechanical properties during the design process of a new wheel. Fatigue limits for steels used in the production of forged and rolled monobloc wheels are today well known thanks to the high experience accumulated during the last century and the large number of full scale tests carried out. In this research, FEM analyses of the innovative wheel centre made of Austempered Cast Iron (ADI) were performed and a full scale fatigue test was planned in order to check the fatigue properties of the material.

Even if the provisions given by [5] can be used to determine the external loads regardless of the kind of wheel (tyred or monobloc), no standards or codes of practice supply valid fatigue criteria for wheel centres, which are characterized by high mean compressive stresses due to the tyre fitting. Similarly, the procedures for the verification of the product requirements described in [6] for monobloc wheels are not applicable.

A full-scale tests was therefore planned at the fatigue test bench available at railway laboratories in Florence, Italy. The test bench, owned by RFI S.p.A., fulfils the requirements described in [6]. About the procedures to correctly estimate the fatigue limit, ref. [7] describes in detail the procedure to perform the tests and process the results in order to find the design fatigue limits. Allowable stresses for ER7 steel grade are given for machined and un-machined wheel webs, and it appears clear that a large number of full-scale fatigue tests and the long experience of railway operators were needed to statistically determine the S-N curve according to the Bastenaire [8] method.

With the bench shown in Fig. 4 it is possible to analyse the fatigue behaviour also in non-purely alternating conditions ( $R \neq -1$ ), which reflects the in-service condition where the lateral load towards the gauge side is higher than the load towards the field side.

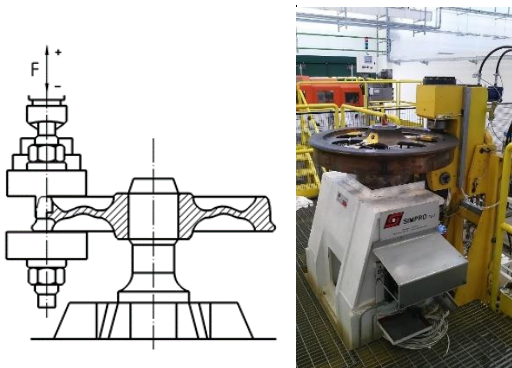

Fig. 4 Sketch of the test bench [6] (left). Photo of the bench with the prototype wheel during testing(right).

Axial loads induce radial stresses in the wheel web and therefore the fatigue limit obtained is related to uniaxial stress state. This is the reason why the whole process described by the combination of [5] and [6] is defined reliable only for axisymmetric wheels, as in these cases the radial stresses due to in-service external loads is higher than circumferential stresses. Even if the new wheel centre is not axisymmetric, the main stress in the spokes is almost radial (uniaxial) as the preload given by tyre mounting generates compression in the spokes that is not fully recovered by external loads. As shown in [1], this improves the fatigue behaviour of the wheel centre as possible surface defects or cracks cannot grow further.

### 3.2. Mean stresses due to tyre fitting

As already said, the main difference with a monobloc wheel is that the tyred wheel has non-negligible mean stresses. Therefore, it was decided to measure these stresses during the fitting of the tyre, in order to validate the FEM model and to properly consider them in the design. Strain gauges were applied on a fully machined wheel according to Fig. 5

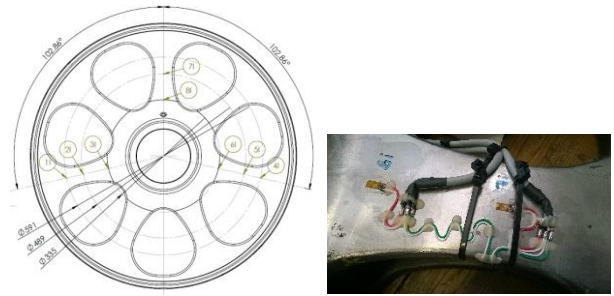

Fig. 5 Strain gauges location for full scale tests (left) and application on a spoke (right). Strain gauges application and checks were managed by the laboratories of Italcertifier S.p.A.,

Tests are ongoing and, in available, results will be reported at the conference.

### 3.3. Test procedure

Due to the high number of samples and resources needed to determine the fatigue limits using high-cycle fatigue methods, such as the staircase method, it was necessary to specify the objectives to be reached with only one wheel prototype. The two available possibilities are discussed hereinafter.

#### 3.3.1. Costant amplitude method

This method is related to the application of a constant force for ten million cycles, as described in the *product qualification* phase [6]. Here the radial stress level to be reached during the test is defined, as the fatigue limit has been previously determined with a certain number of tests. For example, an ER7 axisymmetric wheel with machined web has a fatigue limit of  $\pm 246$  MPa, and therefore tests have to be carried out with a constant stress amplitude of  $\pm 240$  MPa. From this value also the design fatigue limit is derived, applying a safety coefficient such that  $246/1.36 = 180$  MPa.

However, this method is not particular effective at a *design assessment* stage, especially for materials that are applied to wheels for the first time. For example, ADI has fatigue limits that are determined on circular samples with tension-compression tests or rotating bending tests ( $R = -1$ ), without taking into account the effect of the mean stress. Together with proper reduction coefficients to take into account the possible presence of surface defects, these values were used to create the Haigh diagram shown in Fig. 6 and were then used for the assessment of FEM calculation [1], in which the effect of the compressive mean stress is considered to be beneficial as no surface defects can grow further without tensile forces.

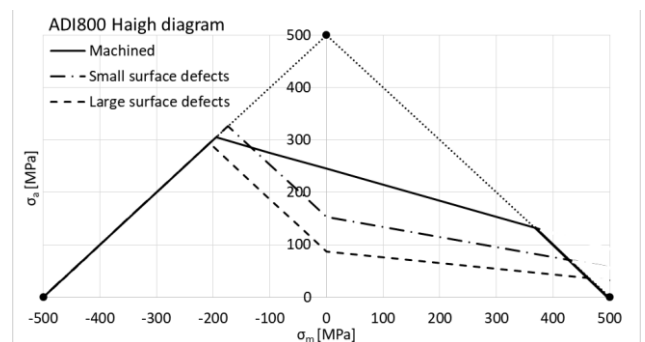

Fig. 6 Haigh diagram for ADI800-10 used for the casted wheel centre.



### 3.3.2. Increasing amplitude method

To find a fatigue limit in the particular condition of the “preloaded” wheel centre, and therefore to verify the hypotheses made for the definition of the Haigh diagram, an accelerated test method, called Locati method [9], was used. In this method the load is increased by a certain number of steps  $T$ , in order to induce an increasing stress and each load step  $i$  is maintained for a number of cycle  $n_i$ .

As the method is based on damage accumulation, it is necessary to define  $j$  S-N curves, with different endurance limits. The curves were created by defining three possible limits at  $10^6$  cycles, and then calculating the coefficients of the Basquin equation  $S = AN^b$  as shown in TABLE II. Thus, for each load step  $i$  is possible to calculate the number of cycle until failure  $N_{ij}$  and then cumulate the damage

$$D_j = \sum_{i=1}^T \frac{n_i}{N_{ij}}$$

TABLE II. PARAMETERS FOR THE DEFINITION OF S-N CURVES

$j$	$S_j$ [MPa]	$A_j$ [-]	$b_j$ [-]
I	100	$5.2 \cdot 10^3$	-0.286
II	200	$2.6 \cdot 10^3$	-0.185
III	300	$1.7 \cdot 10^3$	-0.127

Six steps were defined, starting from a minimum stress value of  $\pm 100$  MPa to a maximum stress value of  $\pm 350$  MPa in the spokes. The forces needed to induce this kind of stress in the wheel centre were preliminary found by FEM simulations. Fig. 7 shows the effect of an alternating force of  $\pm 138$  kN in terms of alternating stress (the effect of the mean stress is discarded by the subtraction of the two opposite results). This force value is considered to be sufficient to generate a stress state higher than the maximum supposed.

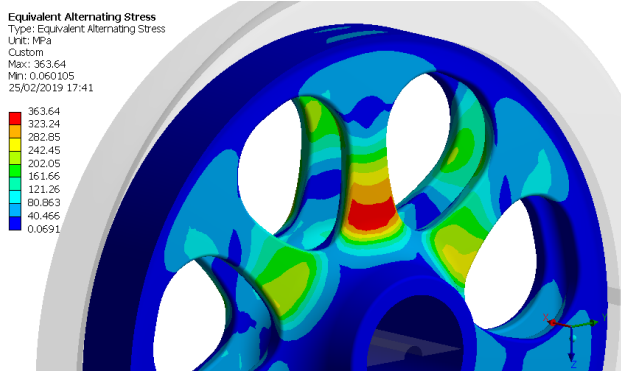

Fig. 7 Alternating stress of the simulated fatigue tests with the final load value of  $\pm 138$  kN.

The three values  $D_I$ ,  $D_{II}$ ,  $D_{III}$ , are finally plotted against the supposed endurance limits  $S_I$ ,  $S_{II}$ ,  $S_{III}$ , in order to obtain an interpolated curve by which it is possible to define the exact fatigue limit when the curve reaches  $D = 1$ .

## 4. LINE TESTS

Two wheelsets were assembled and installed in a bogie that was fitted under the ALn668.1053 DMU belonging to Iseo depot of Trenord (Fig. 8, Fig. 9 Fig. 10).

Several hundred kilometres were run during the tests held on 14-15-16 May 2019 without any problem, reaching a top speed of 90 km/h dictated by the line.



Fig. 8 First wheelset assembled with ADI cast iron wheel centres.



Fig. 9 Bogie of the ALn668.1053 DMU equipped with wheelsets with prototype ADI wheel centres.



Fig. 10 Side view of the ALn668.1053 vehicle during first movements in the Iseo depot of Trenord (14.05.2019)

## 5. VIBROACOUSTIC TESTS

### 5.1. Introduction

Noise emission is attributed mainly to wheels at higher speeds, being the track more responsible for overall levels measured during pass-by at speeds lower than 100÷120 km/h. The ALn668 vehicle was tested at 80 km/h only, speed prescribed by [10], due to line speed limitations, and not at the maximum speed of the vehicle (130 km/h).

The acoustic assessment procedure described in the draft standard [11] is particularly complex and this is not the place to discuss all the activities in detail. A specific paper will be given at the ICA congress [12] as important differences (Fig. 11) as expected at a design stage [1].



Fig. 11 Casted wheel centre and original wheel centre of ALn668.

Stationary vibration tests were conducted to validate the FEM model in the dynamic domain:

- mechanical mobility in free-free conditions;
- estimation of the material damping of the new wheel centre to that of the original steel wheel centre of ALn668;
- estimation of the material damping of ductile cast iron and ADI cast iron.

Stationary noise tests in controlled environment (according to ISO 3744:2010) were performed as well:

- structural-acoustic sound pressure / force frequency response function in a free-field environment under different exciting forces (radial, axial);
- sound power emitted according to ISO 3744:2010

## 5.2. Line tests

Line tests were then performed (end on 16 May 2019):

- measurement of rail roughness [13] ;
- measurement of pass-by noise [10];
- measurement of wheel roughness [13];
- measurement of track decay rate [14].

Pass-by noise resulted in an interesting reduction of emitted noise, despite the fact that track properties are far from perfection and that the emission of the track is dominant at these speeds. Further information will be given in [12].



Fig. 12 FRF measurement to validate the FEM model and to estimate damping properties of ADI cast iron.



Fig. 13 Pass-by noise measurements at 80 km/h near Rovato (Italy) on 16 May 2019.

## 6. CONCLUSIONS

Manufacturing and validation of a new wheel centre made of austempered (ADI) cast iron was presented in this paper. The prototypes brilliantly passed all laboratory tests, leading to a successful and satisfactory validation during line tests.

## REFERENCES

- [1] A. Bracciali, S. Masaggia, G. Megna, E. Veneri, "Quiet and light spoked wheel centres made of Austempered Ductile Iron", Proceedings of the XIX International Wheelset Congress (IWC2019), 16-20 June 2019, Venice, Italy.
- [2] A. Bracciali, G. Caianiello, G. Megna, P. Petreschi, L. Rota, "Dovetail Tyred Wheels – Application to a DMU", Proceedings of the XIX International Wheelset Congress (IWC2019), 16-20 June 2019, Venice, Italy.
- [3] ISO 17804:2005, "Founding — Ausferritic spheroidal graphite cast irons — Classification".
- [4] J. Campbell, "Complete Casting Handbook. Metal Casting Processes, Metallurgy, Techniques and Design, Elsevier, 2011, ISBN-13: 978-1-85617-809-9
- [5] EN13979-1:2011, "Wheelsets and bogies - Monobloc wheels - Technical approval procedure - Part 1: Forged and rolled wheels".
- [6] EN13262:2011, "Wheelsets and bogies - Wheels - Product requirements".
- [7] UIC510-5:2003, "Technical approval of solid wheels"
- [8] ERRI B169 Rp.9, "Définition du cahier des charges des roues – Dimensionnement mécanique; tenue a la fatigue.
- [9] L. Locati, "La fatica dei materiali metallici", Hoepli, Milano, 1950.
- [10] ISO 3095:2013, "Acoustics — Railway applications — Measurement of noise emitted by railbound vehicles".
- [11] prEN 13979-1:2018, Railway applications — Wheelsets and bogies - Monobloc Wheels - Technical approval procedure — Part 1: Forged and rolled wheels.
- [12] A. Bracciali, G. Megna, "Rolling noise emitted by tyred wheels with cast iron spoked wheel centre", accepted for presentation at the 23rd International Congress on Acoustics, the ICA 2019, will be held in Aachen Germany, from Sept. 09-13, 2019.
- [13] prEN 15610:2017, "Railway applications - Acoustics - Rail and wheel roughness measurement related to rolling noise generation".
- [14] EN 15461:2008+A1, "Railway applications - Noise emission - Characterisation of the dynamic properties of track sections for pass by noise measurements".

## Author information



First (Main) author: Andrea Bracciali  
 Title: Professor  
 Research Field: design of running gear  
 Contact Address: via di Santa Marta 3, 50139 Firenze, Italy, c/o Department of Industrial Engineering, University of Florence, Italy.  
 Tel. +39 055 2758746  
 Email: andrea.bracciali@unifi.it