



Contents lists available at ScienceDirect

Algal Research

journal homepage: www.elsevier.com/locate/algal

Techno-economic analysis of microalgal biomass production in a 1-ha Green Wall Panel (GWP®) plant



Mario R. Tredici^{a,*}, Liliana Rodolfi^{a,b}, Natascia Biondi^a, Niccolò Bassi^b, Giacomo Sampietro^b

^a Department of Agrifood Production and Environmental Sciences, University of Florence, Piazzale delle Cascine 24, 50144 Florence, Italy

^b Fotosintetica & Microbiologica S.r.l., Via dei Della Robbia 54, 50132 Florence, Italy

ARTICLE INFO

Article history:

Received 22 April 2016

Received in revised form 31 August 2016

Accepted 4 September 2016

Keywords:

Green Wall Panel

Photobioreactor

Techno-economic analysis

Microalgal biomass

Tetraselmis

ABSTRACT

The objective of this techno-economic analysis (TEA) was to define the production cost of the microalga *Tetraselmis suecica* in a 1-ha plant made of “Green Wall Panel-II” (GWP®-II) photobioreactors. The study was based on an energy analysis carried out for a similar plant located in Tuscany (Italy) and considers the steps from inoculum preparation to the wet algal paste. Costs of equipment and materials were obtained from manufacturers and suppliers, while operating costs and output data (e.g. biomass composition and productivity) were collected during several years of trials at the Fotosintetica & Microbiologica S.r.l. facilities (Florence, Italy). Other data were obtained from Microalghe Camporosso S.r.l. (Imperia, Italy), where a commercial 1500-m² GWP®-I plant is in operation and two 250-m² GWP®-II modules were built and used in the framework of the EU project BIOFAT. This TEA shows that, given a productivity of 36 tonnes per hectare per year, *T. suecica* biomass can be produced at a cost of €12.4 kg⁻¹ (dry weight). Using conservative assumptions it was estimated that at the 100-ha scale the cost will be €5.1 kg⁻¹. Locating the plant in more favorable climatic conditions (e.g. in Tunisia) will allow reaching 54 tonnes per hectare annually and reducing cost to €6.2 kg⁻¹ at the 1-ha scale and to €3.2 kg⁻¹ at the 100-ha scale. The major cost factors are labor at 1-ha scale in Tuscany and capital expenses in all the other cases. This TEA confirms that microalgal technologies have high potential not only for high-value, but also for medium- and low-value products, while the production of biofuels, protein, food and feed seems currently out of reach. However, the global scenario of agriculture commodities is rapidly changing and other factors (e.g. sustainability), besides a pure economic evaluation, will assume greater importance in the future.

© 2016 The Authors. Published by Elsevier B.V. This is an open access article under the CC BY-NC-ND license (<http://creativecommons.org/licenses/by-nc-nd/4.0/>).

1. Introduction¹

Despite the many advantages of microalgal technologies, the world annual production of microalgal biomass is less than 20,000 tonnes, mainly obtained in raceway ponds due to the lower investment necessary to build and operate open systems compared to closed reactors [1,2]. However, raceway ponds suffer from many disadvantages, among which the use of high water volumes per unit area and contamination (by atmospheric pollutants and competing organisms) [1–3]. Closed systems (photobioreactors) reduce freshwater losses, allow to operate at higher cell concentration (which favors harvesting and decreases medium preparation and handling costs), and, above all,

diminish the risks of contamination, which limits the value of the biomass, especially for the cosmetic and food markets [1–2]. Finally, closed systems increase the number of algal species that can be cultivated outdoors [2–3].

Many economic analyses on microalgal biomass production have been published. Most of these studies have been performed for open systems [4–9] or hybrid facilities where the photobioreactors are used to produce the inoculum, while mass production is carried out in open ponds [10–11]. A few economic analyses have focused on closed photobioreactors [4–5,7–9,12–13]. These studies are not comparable because data on yields and costs refer to different culture systems, different strains and diverse environmental and social conditions. Some analyses are based on unrealistic productivities extrapolated from theoretical photosynthetic efficiencies, impossible to be attained with solar radiation [3]. Above all, with the exception of biofuels, these analyses in most cases do not target specific products. Other limitations of many economic analyses on microalgal biomass production are the lack of the necessary level of detail and the fact that they are based on small-scale plants and short-term studies, since commercial facilities do not willingly disclose their production costs. Finally, some of the published analyses do not consider location, which strongly affects

* Corresponding author.

E-mail address: mario.tredici@unifi.it (M.R. Tredici).

¹ **Abbreviations:** GWP, Green Wall Panel; LCA, Life Cycle Analysis; HDPE, High Density Polyethylene; LDPE, Low Density Polyethylene; NL, normal liter; O.D., outer diameter; PAR, photosynthetically active radiation; PV, photovoltaic; PE, polyethylene; PLC, Programmable Logic Controller; PN, nominal pressure; PVC, polyvinyl chloride; NER, Net Energy Ratio; TEA, techno-economic analysis.

Symbols: kWt: kilowatt-thermal (unit of heat-supply capacity used to measure the potential output from a heating plant); Wp: Watt-peak (nominal power of the PV module).

productivity and influences costs (e.g. of manpower, equipment, electricity, fertilizers) and reliability of the operation (e.g. social and regulatory issues). However, when focused on specific target products and based on reliable input data, techno-economic analyses are very useful tools for strategic planning and can assist in evaluating the economic viability of algae-based processes.

The objective of the present TEA was to define with as much detail and certainty as possible the production cost of 1 kg (dry weight) of the microalga *Tetraselmis suecica* F&M-M33 cultivated in a 1-ha plant composed of “Green Wall Panel-II” (GWP®-II) photobioreactors. The study was based on a recent energy analysis carried out for a similar 1-ha GWP®-II plant [14] and considers all the cultivation steps, from inoculum preparation to the obtainment of the wet algal paste. Algal paste, fresh or frozen, can be used as feed, food ingredient, for probiotic production through lactic fermentation or for further extraction and purification of specific compounds (pigments, polyunsaturated fatty acids, vitamins, etc.). When required it can be dewatered by air-drying, spray drying or lyophilization. In order to increase the accuracy of this analysis, costs and lifespans of equipment and materials were obtained from manufacturers and suppliers, while operating costs and output data (biomass composition and productivity) were collected during several years of field trials at the Fotosintetica & Microbiologica S.r.l (F&M) experimental facilities in Sesto Fiorentino (Florence, Italy). Other cost and output data were obtained from Microalge Camporosso S.r.l. (Imperia, Italy), where a commercial 1500-m² GWP®-I plant is in operation since 2009 and two 250-m² GWP®-II modules were built and used for research and demonstration in the framework of the EU FP7 project BIOFAT (<http://www.biofatproject.eu/>).

2. Description of the process

Technologies and operations described in the present analysis are based on those adopted by F&M and Microalge Camporosso. The coast of Tuscany (Italy) was chosen for the plant location because its climatic conditions are similar to those of Sesto Fiorentino (Florence), where the experimental facilities of F&M are located. The 1-ha plant here described is composed of eight 1250-m² GWP®-II modules served by six main ancillary systems (Figs. 1, 2) with the following functions: 1 - culture circulation; 2 - growth medium preparation and supply; 3 - air and flue-gas supply, 4 - culture cooling; 5 - culture harvesting; 6 -

parameter control and data storage. Each system is described in detail in the following paragraphs. There are some modifications in the process here analyzed with respect to that described by Tredici et al. [14], where the energy balance of a 1-ha GWP®-II plant was reported. Among these:

1. Two submersible pumps (instead of one) are used for seawater withdrawal and transfer.
2. Eight blowers (instead of two) are used so as to operate the modules independently (e.g. for growing eight different algae).
3. Eight circulation pumps and eight external heat exchangers (instead of the internal cooling serpentine) are adopted to save energy for cooling-water pumping and simplify the installation and replacement of the plastic chamber.
4. PE is used instead of PVC for general piping.
5. The lifespan of the pumps and of the materials used for the photobioreactor has been increased in relation to their higher quality.

Schematic flow sheets of the complete 1-ha plant and of one of the eight modules composing the plant are shown in Figs. 1 and 2. A list of main equipment and machines is reported in Table 1. Fig. 3 shows a general view and a particular of a 250-m² GWP®-II module in operation at Microalge Camporosso. Fig. 4 shows a GWP®-II plant under construction at Società Agricola Serenissima (Padua, Italy).

2.1. The GWP® photobioreactor

The Green Wall Panel (GWP®) is a flat disposable photobioreactor, designed and patented in 2004. The system is commercialized by F&M and currently used for research and demonstration in the EU FP7 projects BIOFAT (<http://www.biofatproject.eu/>), FUEL4ME (<http://www.fuel4me.eu/>), SPLASH (<http://www.eu-splash.eu/>) and MIRACLES (<http://miraclesproject.eu/>), and in the H2020 projects PHOTOFUEL (<http://www.photofuel.eu/home.php>) and NOMORFILM (<http://www.nomorfilm.eu/>), and for commercial production of microalgae at Microalge Camporosso S.r.l. It is also adopted in R&D projects by several companies (in Chile, Portugal, Sweden, Saudi Arabia, Italy). The original design, the GWP®-I [15–16], has been improved in order to reduce its embodied energy and cost. In the new design, the GWP®-II [17–18] (Figs. 3, 4), the flexible culture chamber is contained within a rigid

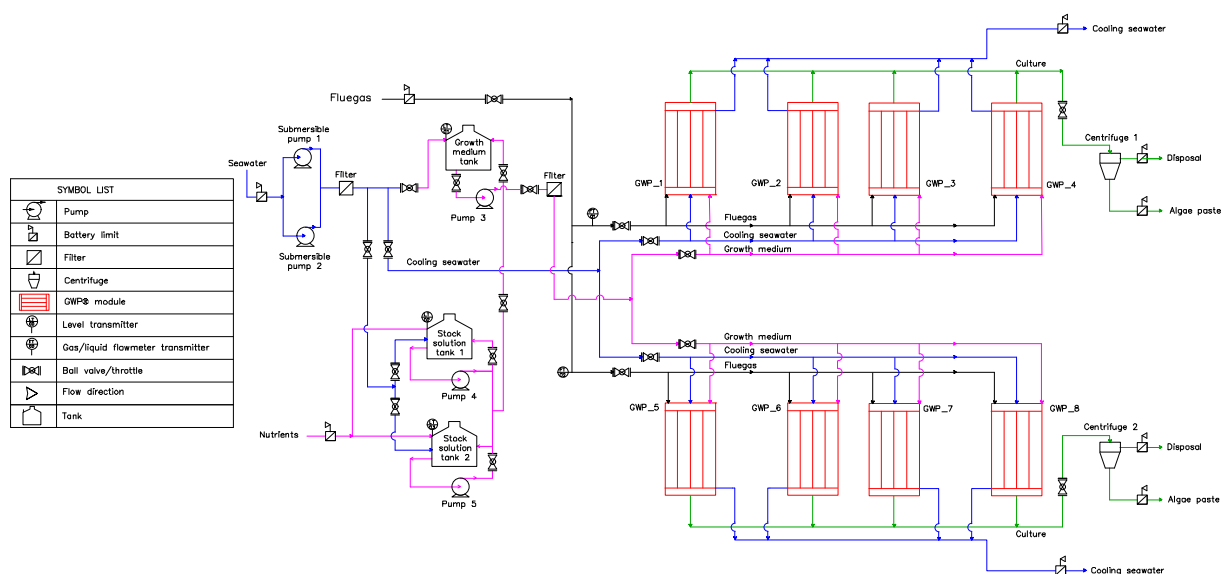

Fig. 1. Scheme of the 1-ha GWP®-II plant and process flow sheet. The plant consists of eight 1250-m² GWP®-II modules (GWP_1 to GWP_8) served by four main pipelines: a) Fluegas (for flue-gas supply to the panels); b) Seawater (the pipeline that, fed by the submersible pumps, brings the seawater, after filtration, to the heat exchangers or delivers it to the storage tank where the growth medium is prepared); c) Nutrients (the pipeline used to transfer the fresh growth medium from the storage tank to the reactors) and d) Culture (the pipeline used to transfer the culture from the modules to the centrifuges).

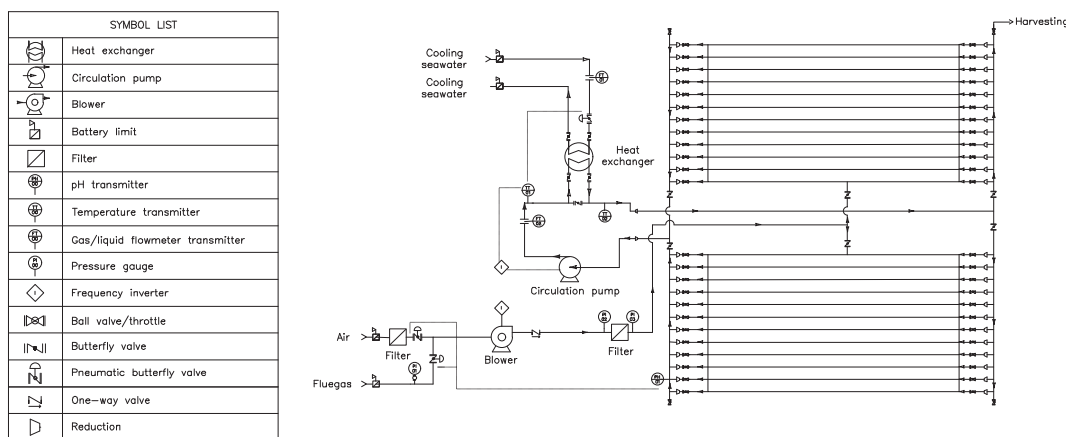

Fig. 2. Scheme of one of the eight 1250-m² GWP®-II modules composing the plant. The module consists of twenty-four 48-m-long panels hydraulically connected at both ends by PVC manifolds that ensure homogeneous distribution of the culture by means of pump circulation. Each panel can be isolated by closing a valve, e.g. to be cleaned or for maintenance. The module displays a total panel surface area of 800 m² and occupies a land surface area of 1250 m² (including piping and manifolds). Pipelines for culture circulation, seawater transfer, medium preparation, culture movement and gas supply, pumps, blowers, filters and the heat exchangers are shown.

frame made by a number of vertical stainless steel uprights directly driven into a wooden base and connected at the top by two horizontal stainless steel U-shaped bars. The removal of the grids (that characterized the GWP®-I) and the reduction of the height of the culture chamber from 1 to 0.7 m, allowed the adoption of a much lighter containment frame and a significant decrease in embodied energy and cost of the reactor. The culture chamber is made of a PAR-transparent (>90%) LDPE film (0.3-mm thickness). When in a vertical position and filled up to the top (0.7 m), the culture chamber has an average thickness (light path) of about 4.5 cm. Thus, one square meter of panel holds 45 L of culture, which corresponds to 31.5 L per linear meter of panel. Mixing, gas/liquid mass-transfer and carbon supply are achieved by bubbling air or a CO₂-enriched gas (e.g. flue-gas) through a perforated pipe, which runs at the bottom of the culture chamber. Thermoregulation is provided by circulating the culture through an external heat exchanger. The main advantages of the GWP®-II are easiness of operation, adaptability, suitability to fragile strains, the capacity to be scaled-up, and the low construction cost compared to other, especially tubular [12], closed systems. A new design, the GWP®-III.A, is commercialized by F&M. In this last system, thanks to a pneumatic cylinder that automatically changes

the panel inclination, light interception is optimized, energy consumption for cooling is reduced and both panel walls can be alternatively cleaned by bubble scouring.

The 1-ha plant considered in this analysis is made of eight identical 1250-m² GWP®-II modules. Each module comprises twenty-four 48-m-long panels. The panels that form a module are hydraulically connected at both ends by PVC manifolds that ensure homogeneous distribution of the culture (Figs. 2, 3). The culture is circulated through the 24 panels belonging to the same module and the connecting manifolds by an open impeller pump (circulation pump). The circulation flow is shown in Fig. 2. Each panel can be isolated by closing a valve, e.g. for cleaning or for maintenance, without interrupting operations. Each module has a total panel surface area of 800 m², an illuminated surface area of 1600 m² (since both panel walls receive light), and occupies a land surface area of 1250 m² (including manifolds). The eight modules display a total panel area of 6400 m² and a total illuminated surface area of 12,800 m². Each module contains 39.4 m³ of culture (including that in the manifolds) for a total plant culture volume of 315 m³. The panels are placed in parallel rows spaced of 1 m and are E-W oriented (one wall of the panel is facing east and the other west) in order to

Table 1

List of main plant equipment and machines and their characteristics and function in the plant (see also schemes shown in Figs. 1 and 2).

Machine or equipment	Number of units	Other characteristics and function
GWP®-II module (including manifolds)	8	Composed of twenty-four 48-m-long panels. Total panel surface area 800 m ² ; occupied land area 1250 m ² ; culture volume 39.4 m ³
7.5-kW blower	8	Three-lobe blower regulated by a frequency inverter for culture bubbling. 520 Nm ³ h ⁻¹ ; 0.12 bar; 7.5 kW; 400 V - 50 Hz
10-kW submersible pump (PUMP 1 and 2)	2	Submersible pump regulated by a frequency inverter for seawater withdrawal and transfer. 300 m ³ h ⁻¹ ; 1.5 bar; 10 kW; 400 V - 50 Hz
5.5-kW centrifugal pump (PUMP 3)	1	Centrifugal pump to transfer the growth medium from the growth medium tank to a filter (1 μm) and then to the modules. 40 m ³ h ⁻¹ ; 2.7 bar; 5.5 kW; 400 V - 50 Hz
0.75-kW centrifugal pump (PUMP 4 and 5)	2	Centrifugal pump to deliver stock solutions to the growth medium tank. 4.8 m ³ h ⁻¹ ; 2.4 bar; 0.75 kW; 400 V - 50 Hz.
3.75-kW circulation pump	8	Open impeller centrifugal pump regulated by a frequency inverter to circulate the culture and move it through the heat exchanger. 97 m ³ h ⁻¹ ; 1 bar; 3.75 kW; 400 V - 50 Hz
Centrifugal separator (Centrifuge 1 and 2)	2	Westfalia centrifugal separator for culture harvesting. 4 m ³ h ⁻¹ ; 7.5 kW; 400 V - 50 Hz
Heat exchanger	8	Titanium plate heat exchanger for culture cooling. 620 kWt
Stock solution tank (stock solution tank 1 and 2)	2	1-m ³ HDPE tank for preparation of nutrient stock solution
Growth medium tank	1	50-m ³ galvanized steel tank for growth medium preparation and storage
PLC system	1	System to measure and control culture parameters
Seawater pipeline	1	Pipeline to deliver seawater to the medium preparation tank and to the heat exchangers. PE 100 PN10; O.D. 225–200 mm
Culture harvesting pipeline	1	Pipeline to transfer culture from modules to the centrifugal separators. PE 100 PN10; O.D. 63 mm
Air/flue-gas pipeline	1	Pipeline to deliver flue gas to the modules. PE 100 PN10; O.D. 250–225–200–140 mm
Growth medium pipeline	1	Pipeline to transfer growth medium to the modules. PE 100 PN10; O.D. 75 mm.
Culture circulation pipeline (manifolds)	1	Pipeline to pump the culture through the plate heat exchanger and connect the panels of each module. PVC PN6; O.D. 200–180–110–63 mm



Fig. 3. 250-m² GWP®-II modules at Microalge Camporosso (Imperia, Italy). Modules used at Microalge Camporosso within the activities of the EU FP7 project BIOFAT: a) general view of the plant; b) a particular of a module with the skid containing the electric cabinet, the control system, the blower, the pump, the plate heat exchanger and valves.

optimize solar radiation capture during the cultivation season and reduce solar heating (and thus cooling needs) in the central daylight hours.

2.2. Air and flue-gas supply

In any photoautotrophic algal culture, carbon dioxide is necessary as source of carbon for the photosynthetic process and pH regulation. In the plant here considered, typically, CO₂-enriched gas (e.g. flue-gas with 10–15% CO₂) is supplied to the modules according to pH and culture growth. Mixing (required to avoid sedimentation and ensure a suitable gas-liquid mass transfer) is obtained by air and/or gas bubbling. Each GWP®-II module is equipped with its own gas supply system (Figs. 1, 2) in order to independently regulate pH and bubbling rate. A three-lobe blower (7.5 kW) provides compressed (0.12 bar) air or flue-gas to the panels. The culture is bubbled at the flow rate of 0.22 NL L⁻¹ min⁻¹ (520 Nm³ h⁻¹) during daytime, a rate sufficient to

avoid sedimentation, ensure the desired light-dark cycle and remove the oxygen produced by photosynthesis. During the night the flow rate is decreased to 0.12 NL L⁻¹ min⁻¹ (284 Nm³ h⁻¹) to reduce electrical energy consumption. Bubbling rate is regulated by the blower frequency inverter. The power consumption for mixing was calculated as reported by Tredici et al. [14]. A main pipeline (PE 100 PN10) of decreasing diameter (O.D. 250–225–200–140 mm) delivers the flue-gas to the modules. When the pH value of the culture exceeds the set point, bubbling switches from air to flue-gas, until the pH reaches the pre-set value. In this work we have assumed that the source of the CO₂-enriched gas (e.g. a power plant, a fermenter or an anaerobic digester) is available next to the algal plant. The lifespan of the blower and the PE pipeline for gas supply was assumed to be 20 years.

2.3. Culture cooling and circulation

Culture circulation allows for reducing the gradients of pH, temperature and nutrients and achieves cooling when the culture passes through the heat exchanger. After filtration (60-µm pore size), seawater (assumed to be available at close distance from the plant at an average temperature of 20 °C) is pumped through the titanium plate heat exchangers (620 kWt), and then back to the sea by means of two submersible pumps (300 m³ h⁻¹; 1.5 bar; 10 kW) using a dedicated pipeline (PE 100 PN10; O.D. 225–200 mm) (Figs. 1, 2). Heat transfer from culture to cooling water is obtained by circulating the culture through the heat exchanger by means of an open impeller centrifugal pump (97 m³ h⁻¹; 1 bar; 3.75 kW). When cooling is not necessary (e.g. in winter, in cloudy days or during the night) the culture flow-rate is reduced by acting on the circulation pump frequency inverter. The flow rate of the cooling seawater is regulated by the control system, which acts on the frequency inverter of the submersible pumps in function of the cooling needs, and besides opens/closes the inlet valve of the modules. The seawater flow-rate necessary to keep the optimal temperature mainly depends on solar radiation impinging on the panels and convective heat exchange between the panel walls and the air. The size of the cooling pipeline and the power of the submersible and circulation pumps to attain the necessary flow-rate of seawater and culture during hours of maximal irradiance was calculated as reported in Tredici et al. [14]. All the pumps are made of AISI 316 stainless steel to prevent corrosion. For these machines as well as for the PVC pipes and fittings needed for culture circulation a lifespan of 10 years was considered.

2.4. Culture harvesting

The plant is equipped with two centrifugal separators (Westfalia mod. SSD8; 4 m³ h⁻¹; 7.5 kW) able to harvest 80 m³ of culture (about 25% of the total plant volume) in 10 h with a high separation efficiency (>95%). The open impeller pumps described in the previous section (culture circulation pumps) are used to daily withdraw part of the culture from the panels and feed one of the separators through a dedicated pipeline (PE 100 PN10; O.D. 63 mm) (Fig. 1). A lifespan of 25 years was

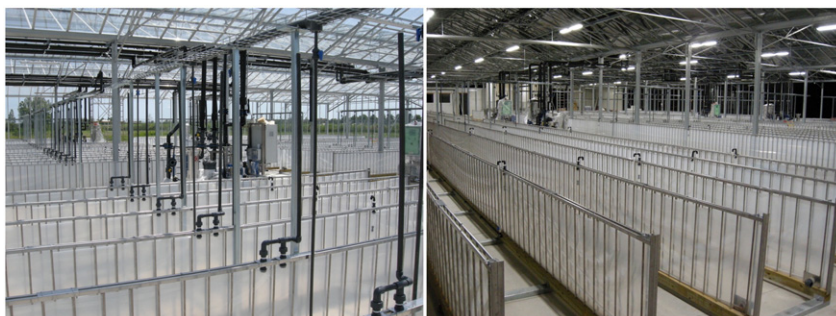

Fig. 4. 1000-m² GWP®-II plant under construction (Padua, Italy). GWP®-II plant under construction at Società Agricola Serenissima (Conche di Codevigo, Padua, Italy).

assumed for the separators. The obtained algal paste (about 20% dry weight) is collected and the exhausted culture medium is disposed of. Wastewater treatment costs were not considered as we assumed that the exhausted medium contains negligible amounts of nutrients and that, after centrifugation, suspended solids and organic load in the exhausted medium are below the thresholds for discharge in the sea according to national and regional regulations.

2.5. Growth medium preparation and supply

Nutrients (technical grade fertilizers containing N and P) are daily added to the cultures according to productivity and the N and P content of the biomass. A concentrated nutrient stock solution is prepared in two HDPE 1-m³ tanks (Fig. 1) and delivered to the growth medium tank (a 50-m³ galvanized steel tank lined with a PVC membrane for insulation) by means of a centrifugal pump (4.8 m³ h⁻¹; 2.4 bar; 0.75 kW). Natural seawater is pumped by means of one of the submersible pumps described above to a filter (60- μ m pore size) and then to the medium tank, where the growth medium is prepared and stored (Fig. 1). One centrifugal pump (40 m³ h⁻¹; 2.7 bar; 5.5 kW) is then used to transfer the growth medium from the 50-m³ storage tank to a filter (1- μ m pore size) and then to the modules through the dedicated pipeline (PE 100 PN10; O.D. 75 mm). The lifespan of these pumps was assumed to be 10 years.

2.6. Parameters control and data storage

An industrial PLC system continuously measures and regulates pH and temperature of the cultures by activating the different valves and by regulating the rotational speed of the submersible pumps, of the blowers and of the frequency-controlled circulation pumps. Each module is independently controlled, thus allowing cultivation of the same algal strain under different conditions or of different (up to eight) algae at the same time. Each module is also provided with a paddlewheel flow-meter for measuring cooling water consumption. Two thermal mass flow-meters, installed on the main flue-gas pipeline, measure total flue-gas consumption.

3. Cost calculation methodology

The costs of the process (production of *T. suecica* biomass in a 1-ha GWP®-II plant) were divided into capital (CAPEX) and annual operating costs (OPEX). Contingencies and decommissioning costs were not considered. The sum of OPEX and total fixed capital costs per annum was divided by the annual biomass productivity to obtain the cost of 1 kg (dry weight) of biomass produced as wet paste (20% dry weight). A detailed description of the incurred capital and operating costs is reported below. According to the quantity and quality of technical information available and the level of design, the present cost analysis can be classified between a preliminary and a definitive estimate, with an accuracy within $\pm 15\%$ [19].

3.1. Calculation of capital costs (CAPEX)

CAPEX are costs incurred to acquire and install the necessary machinery, equipment, piping, controls and services. Capital cost per annum is considered here from an engineering viewpoint as the initial value of the asset divided by the service life or lifespan (years) of the asset itself applying the straight-line depreciation method [19]. The salvage (residual) value of all the tangible assets used was considered to be zero. The value of purchased land was not depreciated, since it usually does not decrease with time and use [19]. Intangible assets (e.g. patents) were not considered. We assumed that in the location where the plant is to be built, infrastructures (electricity, water supply, roads and other services) were available.

Capital costs can be divided into direct and indirect costs. Direct costs represent monetary expenses incurred in the purchase of all the materials and equipment necessary for running the plant. The indirect capital costs considered in the present analysis were: engineering & supervision, installation, taxes & insurance. Taxes & insurance were estimated to be 1% of direct capital costs plus land [19]. Engineering & supervision and installation were estimated to be 5 and 10% of direct capital costs [19]. All the indirect capital costs were distributed over the 25-year lifespan of the plant. An interest rate of 5% was assumed, which for a 10-year loan with an equity of 40%, amounts to 17.7% of total fixed capital costs including land. The total amount of interest in the ten years was distributed over the 25-year lifespan of the plant. In order to guarantee a satisfactory accuracy ($\pm 15\%$) of the analysis, costs of materials and equipment were directly obtained from manufacturers and suppliers. Lifespan of machinery, i.e., the period during which the component is economically usable, was estimated according to our experience and communications by manufacturers and suppliers, assuming that machines are subjected to adequate maintenance.

3.2. Calculation of operating costs (OPEX)

OPEX are those expenses incurred as a result of normal operations. OPEX have been divided into direct (labor, fertilizers and chemicals, electrical energy and consumables) and indirect (maintenance, overhead and administration) operating costs.

3.2.1. Labor

The 1-ha GWP®-II plant was designed so as to minimize manpower, thus several operations have been automatized. However, plant maintenance and algae cultivation still require a great deal of human skill and practice. According to our experience six employees with different roles and retributions are required to operate the facility. These are a plant supervisor responsible for work coordination, a biologist responsible for monitoring all aspects related to cultivation (culture health, formulation of the growth medium, determination of harvesting time, nutrient replenishment, etc.) and four workers in charge of growth medium preparation, harvesting, culture sampling and routine analyses, ordinary and extraordinary maintenance, and surveillance. Personnel are one-shift, full-time and year-round employed, although the cultivation period lasts only eight months a year. During the non-operative months personnel are in charge of inoculum maintenance, plant maintenance and up-grade, marketing, etc. Labor costs were calculated from average costs for each category in Tuscany (Italy) [20].

3.2.2. Electrical energy

The electrical energy required for daily machinery operations was calculated multiplying the power absorbed by each machine (pumps, blowers, centrifuges, etc.) by its operation time. Absorbed power for each machine was directly measured in existing plants at F&M and Microalga Camporosso or calculated according to design parameters as indicated in Tredici et al. [14]. A cost for electrical energy (industrial use) of $\text{€}0.175 \text{ kWh}^{-1}$ was assumed [21].

3.2.3. Fertilizers, chemicals and consumables

Microalgae, as other organisms, need several macro- and micronutrients to grow. Seawater provides many of them in sufficient amount. In general, only carbon, nitrogen, phosphorus and iron need to be added to the seawater-based medium to ensure maximum productivity. Nutrients are supplied as inorganic salts (technical grade), except carbon, which is furnished during daylight hours by bubbling flue-gas into the culture. The amount of fertilizers used was calculated from biomass productivity considering an average content in *T. suecica* F&M-M33 of 7% N and 0.7% P. A nutrient uptake efficiency of 100%, that can be achieved by carefully modulating the addition of nutrients according to algal growth, was assumed. Since the plant is located within an industrial area next to a flue-gas generator, the cost of flue-gas cooling,

treatment and transfer to the plant battery limits was considered negligible. The cost of flue-gas distribution (energy consumption, piping, etc.) from the plant battery to the reactors was instead included. Other chemicals, mainly for cleaning and disinfection of the panels, are regularly used (for example NaClO, HCl) and were here taken into account. Among consumables we have included pH probes, temperature sensors and filter cartridges for air/flue-gas and seawater. The plastic culture chamber, although changed every year, was included in direct CAPEX.

3.2.4. Maintenance, overhead and administration

A programmed maintenance of photobioreactors (including cleaning and repairing of the polyethylene chamber) and of the machinery is needed for correct plant functionality. An annual cost of 5% of direct CAPEX was assumed for maintenance [19]. Overhead and administration costs were both considered 10% of direct OPEX.

3.3. Biomass production

3.3.1. The microalga

Tetraselmis suecica is a marine green flagellate of the class Prasinophyceae, division Chlorophyta. When grown under optimal conditions *T. suecica* F&M-M33 has a 40–50% protein content and about 20% lipids [22]. Under nutrient stress (e.g. nitrogen deprivation) it accumulates mainly carbohydrates. One of the most important applications of the microalga is in aquaculture for rearing zooplankton and larval stages of marine fish, bivalve mollusks and crustaceans [23]. Due to its high content of good quality protein, vitamins and polyunsaturated fatty acids and its probiotic activity [23], this organism represents an alternative ingredient for animal feed preparation. Active ingredients extracted from this microalga are currently used in the development of novel cosmetic formulations [24]. It has also potential for carbon dioxide fixation in combination with biofuel production [3].

3.3.2. Biomass productivity

Given the chosen location (Tuscan coast, Italy) the cultivation season was limited to the eight sunniest months (from March to October). Based on productivity and solar radiation data collected in previous years at the F&M experimental plant in Sesto Fiorentino, we calculated the relationship between productivity (g m^{-2} panel area d^{-1}) and the amount of solar radiation intercepted by the panels (MJ m^{-2} panel area d^{-1}). From this relationship and the total solar radiation intercepted by the panels per unit plant land area (MJ m^{-2} land area d^{-1}) the average productivity per unit plant land area (g m^{-2} land area d^{-1}) of *T. suecica* F&M-M33 grown in vertical GWP®-II reactors was estimated for each month of the cultivation season (Fig. 5). Total solar radiation intercepted by the panels per unit plant area was calculated from the global solar radiation on the horizontal (average of the last 50 years) at the Tuscan coast latitude (<http://re.jrc.ec.europa.eu/pvgis/>) using equations reported by Kreith and Kreider [25]. The average productivity for the eight operation months was $15 \text{ g m}^{-2} \text{ d}^{-1}$, corresponding to an annual yield of 36 tonnes of dry biomass (collected as wet paste at 20% dry weight) per hectare. With *T. suecica* F&M-M33 limited biofouling occurs and monthly cleaning of the culture chamber suffices. Since cleaning is carried out during night, productivity is not affected.

4. Results

A detailed description of capital and operating costs is reported in the following paragraphs.

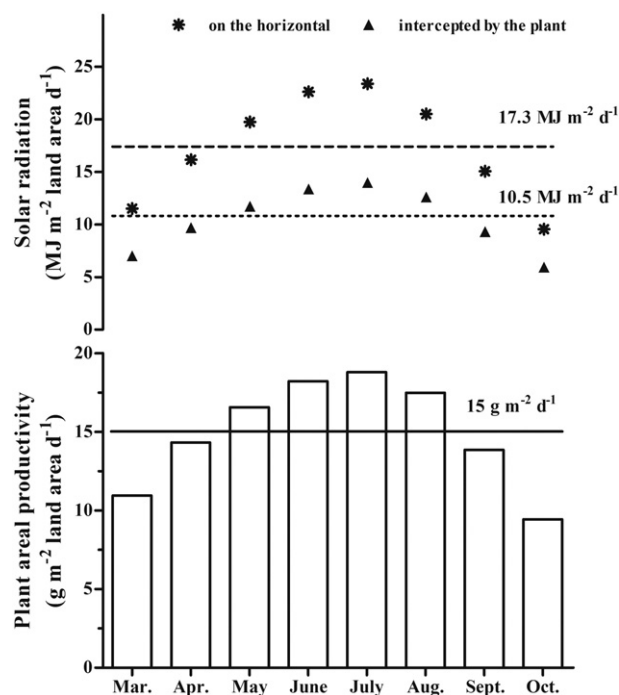

Fig. 5. Monthly productivity of the 1-ha GWP®-II plant in Tuscany. Monthly global solar radiation on the horizontal, monthly radiation intercepted by the panels and monthly plant areal productivity of *Tetraselmis suecica* F&M-M33 cultivated in a 1-ha GWP®-II plant in Tuscany.

4.1. Direct capital cost

4.1.1. The GWP®-II photobioreactor

The 1-ha GWP®-II plant is composed of eight 1250-m² GWP®-II modules, each consisting of twenty-four 48-m-long panels. Materials necessary to build the panels and their costs are listed in Table 2.

The stainless steel uprights represent the most expensive component of the panel (more than half of the total cost), but given their long lifespan (25 years), their annual capital cost (€1444) is similar to that of the culture chamber (€1382) and of the wooden base (€1190) (Table 2). Since, to be on the safe side, we consider it necessary to change the polyethylene chamber every year, this component becomes very expensive in terms of annual capital cost. The expenses for the remaining components of the GWP® module are minor. The eight modules composing the 1-ha plant cost in total €505,320 and have an annual capital cost of €35,225 (Tables 2, 6).

4.1.2. Piping, fittings, valves and tanks

The most expensive pipelines are those for culture circulation (€49,721) and air/flue-gas supply (€46,329) (Table 3). Cost of piping for harvesting is minor. The total cost of piping (including fittings and valves) for the 1-ha GWP® plant amounts to €140,945 with an annual capital cost of €9534 (Tables 3, 6).

4.1.3. Machinery and equipment

This category includes all the mechanical components and equipment (heat exchangers, pumps, blowers and centrifuges) used to produce and process the algal biomass in the 1-ha plant. The most expensive machines are the eight heat exchangers (€129,792) and the two Westfalia centrifugal separators (€112,000). The total capital expenses for this category amount to €376,504. The annual capital cost is €22,321 (Tables 4, 6).

Table 2

Main parts, unitary costs, total cost, lifespan and capital cost per annum of a 1250-m² GWP®-II module. The total cost of the eight modules that form the 1-ha plant is also reported.

Component	Description	Unit	Quantity for one module	Unit cost (€)	Total cost (€)	Lifespan	
						(y)	Capital cost per annum (€ y ⁻¹)
1	Wooden base with fastening bars	m	1152	15.5	17,856	15	1190
2	Stainless steel uprights	pcs	15,360	2.35	36,096	25	1444
3	Lateral bars	pcs	48	8	384	25	15
4	Top "U" shaped bars	m	2304	1.6	3686	25	148
5	LDPE culture chamber	m	1152	1.2	1382	1	1382
6	Air/flue-gas sparger tubing	m	1152	0.4	461	5	92
7	Screws, nuts, bolts, etc.	–	–	–	3300	25	132
Total cost of one module					63,165		4403
TOTAL COST OF THE EIGHT MODULES					505,320		35,225

4.1.4. Electrical equipment, instrumentation & control system

One industrial control system (PLC) serves the eight modules. The system, including pH and temperature controllers, switches, fittings, grounding, wiring and the electrical cabinet, costs €233,000. Gas and liquid flow-meters cost €29,328. The total cost of the control system and electrical equipment is €272,728, with an annual capital cost of €13,293 (Tables 5, 6).

4.1.5. Field laboratory and land

A microbiological field laboratory within a portable shipping container and an inoculum preparation room for a total cost of €50,000 were considered. Other buildings and civil engineering works are not included. Service life for the laboratory and the inoculum room was estimated to be 25 years for an annual capital cost of €2000 (Table 6). Land cost was estimated to be €100,000 and was not depreciated (Table 6).

4.2. Indirect capital cost

Total indirect capital costs, which include engineering & supervision, installation, and taxes & insurance were estimated to be €216,280 with an annual capital cost of €8651. Total capital investment amounts to €1,661,777. Considering interest the annual total fixed capital cost is €101,260 (Table 6).

Table 3

Cost of piping, fittings, valves, tanks for the 1-ha GWP®-II plant.

Process line	Total cost (€)	Lifespan (y)	Capital cost per annum (€ y ⁻¹)
Cooling			
Piping	21,122	20	1056
Fittings + valves	6448	20	322
Sub-total	27,570		1379
Air/Flue gas			
Piping	21,958	20	1098
Fittings + valves	24,371	20	1219
Sub-total	46,329		2317
Culture circulation (manifolds)			
Piping	12,553	10	1255
Fittings + valves	37,168	10	3717
Sub-total	49,721		4972
Culture harvesting			
Piping	940	20	47
Fittings + valves	4000	20	200
Sub-total	4940		247
Culture medium preparation & supply			
Piping	1185	20	59
Fittings + valves	6000	20	300
Tanks	5200	20	260
Sub-total	12,385		619
TOTAL	140,945		9534

4.3. Operating cost (OPEX)

4.3.1. Labor

Labor costs are shown in Table 7. Salaries were taken from average labor costs in Tuscany (Italy) for each category [20]. The total annual cost of labor amounts to €179,400.

4.3.2. Fertilizers

The amount and cost of technical grade N and P fertilizers needed to sustain a production of 36 tonnes of *T. suecica* biomass are shown in Table 8. The requirement of sodium nitrate is about 15 tonnes per hectare per year [14], for a total expense of €6120. The expense for sodium dihydrogen phosphate is much lower (€1500). The total cost for fertilizer purchase is €7620 per year.

4.3.3. Electricity

The major electrical energy expenditure encountered in the plant is that for the blowers (128,784 kWh y⁻¹) that operate continuously (5760 h per year) during the 240-day cultivation period (Table 9). The daylight (10 h on average) hourly energy consumption of the eight blowers is on average 30 kWh. During the remaining period (14 h on average), the hourly energy consumption decreases to 16.9 kWh thanks to the reduction of bubbling from 0.22 to 0.12 NL L⁻¹ min⁻¹. Annual electrical energy consumption of the two submersible pumps mainly used for seawater withdrawal and circulation is 25,200 kWh. They operate for 1680 h per year (7 h per day on average) at an hourly consumption rate of about 15 kWh. An important electrical consumption (35,040 kWh y⁻¹) is represented by culture circulation. As described earlier, each module is provided with an open impeller pump that circulates the culture for the whole day through the panels and manifolds and the heat exchangers. Since the rotational speed of the pumps is frequency controlled, energy consumption is optimized. The energy consumption of the pumps used to transfer the medium or the culture represents a minor expenditure. The two centrifugal separators, with a nominal hydraulic capacity of 6 m³ h⁻¹, operatively corresponding to 4 m³ h⁻¹, consume 9.5 kWh per hour and work for 10 h per day, leading to an annual consumption of 22,800 kWh. Given the annual energy consumption of the different machines and the average cost of industrial electricity in Italy [21], the total electrical energy expenditure amounts to €37,526. By far the major cost is that for culture bubbling (€22,537) (Table 9).

4.3.4. Consumables, maintenance, overhead and administration

In this study we have considered necessary to replace every year pH probes, temperature sensors, and filters (for water and air/flue-gas). Although filter housings can be sterilized, it is advisable to replace the cartridges every year to prevent contamination or machinery damage. An annual expense of €5000 for purchasing disinfecting agents and other chemicals required for cleaning the reactor was also assumed. Total cost of consumables, besides fertilizers, amounts to €6980 (Table 10).

Table 4
Cost of machines and other equipment needed to run the 1-ha GWP®-II plant.

Description	Quantity (units)	Unitary cost (€)	Total cost (€)	Lifespan (y)	Capital cost per annum (€ y ⁻¹)
Machines					
10 kW submersible pump ^a	2	18,480	36,960	10	3696
7.5 kW three-lobe blower	8	5300	42,400	20	2120
3.75 kW circulation pump	8	2750	22,000	10	2200
5.5 kW centrifugal pump	1	1668	1668	10	167
0.75 kW centrifugal pump	2	442	884	10	88
7.5 kW centrifugal separator	2	56,000	112,000	25	4480
Equipment					
Heat exchanger	8	16,224	129,792	20	6490
Filtration system for air/flue-gas	8	2600	20,800	10	2080
Filtration system + UV for seawater	1	10,000	10,000	10	1000
TOTAL			376,504		22,321

^a The cost for seawater pumping includes a fully-equipped pump station (pumps, support structure, electrical connection, dedicated piping, valves).

The cost for tap water purchase was not considered. Worn or broken parts of the reactors and of the ancillary equipment need to be replaced to guarantee proper work. These costs were included in maintenance which amounts to €67,275 (Table 10). Finally, both annual overhead and administration costs amounted to €23,153 (Table 10). Total OPEX were €345,107.

4.4. Biomass production cost

Given total OPEX of €345,107 and a total fixed capital per annum of €101,260, the total annual cost for plant operation is €446,367, which, with an annual productivity of 36 tonnes (dry weight), leads to a *T. suecica* biomass unitary cost of €12.4 kg⁻¹. Labor contributes for €5, maintenance for €1.9, electricity for €1, capital costs for €2.8.

5. Prospects of improvement

Estimated production costs of algal biomass in commercial facilities range from about \$5 to over \$1000 kg⁻¹ [26], with the lowest cost for *Dunaliella salina* grown in very large natural ponds in Australia and *Arthrospira* cultivated in open raceways in India and China. Cost of production in commercial closed reactors averages €50 kg⁻¹, much depending on the productivity of the species cultivated. Thus a cost of €12.4 kg⁻¹ for *T. suecica* biomass produced in the GWP®-II is unexpectedly low, considering the fact that the cultivation is not carried out in the best climatic conditions. This cost does not enable the use of the biomass as feedstock for commodities (food, feed, biofuels), but would make largely profitable many other commercial applications. We have assumed that significant cost reductions would be achieved by: 1 – integrating the GWP® with photovoltaic (PV); 2 – cultivating a thermo-tolerant strain that requires no cooling; 3 – scaling up the plant to 100 ha; 4 – deploying the plant in a more suitable location where cultivation can be carried out along the whole year. All these potential improvements have been analyzed by reiterating the TEA with the same methodology used for the base case (1-ha plant in Tuscany with cooling).

Using energy consumption and productivity data obtained at F&M facilities with GWP®-II reactors integrated with PV elements, a NER analysis was carried out, which showed a substantial benefit of the integration (the NER increased from 0.8 to 1.7) [14]. However, PV integration does not lead to an economic benefit of analogous importance. Considering for PV a cost installed of €2.6 per Wp [27] and the need of 250,000 Wp to provide the electricity required to run the 1-ha plant, PV integration will increase total direct capital costs of about €650,000. Despite that in the PV integrated GWP®-II plant all the electrical energy will be autonomously produced without using extra space (the PV strips would be directly applied on the panel surface as we successfully tested at pilot scale), the biomass unitary cost will not change significantly. It is foreseen that the cost of PV cells will halve in 2020 [28]. In this case the biomass cost in the PV integrated GWP®-II will decrease to a level which could make the integration worthy. In case our selected algal strain grows well up to 45–50 °C, by adopting a particular orientation and inclination of the panels and, eventually, emergency cooling by spraying seawater on the panels with crop irrigators (sprinklers), the cooling system can be removed (Sampietro and Tredici, unpublished). Thus, a thermo-tolerant strain will allow significant reductions both in CAPEX and OPEX bringing the biomass cost to €11.1 kg⁻¹ (Table 11).

At 100-ha scale total CAPEX per hectare can be reduced of about 30% compared to the 1-ha scale. This CAPEX reduction per hectare was obtained using Eq. (1) [12] for scaling-up by a factor of ten (from 1 to 10 ha) and further scaling up of another ten factor (up to 100 ha) by multiplying the number of units. The need of personnel in the 100-ha plant was estimated to be 1 plant supervisor, 10 biologists/technicians and 40 field workers. Half an employee per hectare is a much higher workforce than that adopted in two recent analyses on plant based on closed reactors at the same scale [4,13]. The electricity cost at 100-ha scale was reduced from €0.175 to €0.145 kWh⁻¹ in relation to the increased annual consumption [21]. Similarly to CAPEX, costs per hectare of fertilizers and other consumables were reduced of 30%. With these assumptions, that we consider conservative, the final cost of the

Table 5
Capital costs of electrical equipment, instrumentation & control system for the 1-ha GWP®-II plant.

Description	Total cost (€)	Lifespan (y)	Capital cost per annum (€ y ⁻¹)
Gas and liquid flow-meters	29,328	10	2933
Inverters	10,400	10	1040
Electrical cabinets, wiring, PLC and control system	233,000	25	9320
TOTAL	272,728		13,293

Table 6

Direct and indirect capital costs, total capital investment, and total fixed capital per annum of the 1-ha GWP®-II plant.

	Cost (€)	Capital cost per annum (€ y ⁻¹)
DIRECT CAPITAL COSTS		
GWP®-II photobioreactor	505,320	35,225
Piping, fittings, valves and tanks	140,945	9534
Machinery and equipment	376,504	22,321
Electrical equipment, instrumentation and controls	272,728	13,293
Field laboratory	50,000	2000
Total direct capital costs (TDC)	1,345,497	82,373
INDIRECT CAPITAL COSTS		
Engineering & supervision (5% of TDC)	67,275	2691
Installation (10% of TDC)	134,550	5382
Taxes & insurance (1% of TDC + Land)	14,455	578
Total indirect capital costs	216,280	8651
FIXED CAPITAL INVESTMENT (FCI)		
Land ^a	1,561,777	91,024
	100,000	–
TOTAL CAPITAL INVESTMENT(TCI)	1,661,777	91,024
Interest ^b	255,893	10,236
TOTAL FIXED CAPITAL PER ANNUM	–	101,260

^a Land does not depreciate [19] and is not considered in the Capital cost per annum calculation, but is included in Interest.

^b Interest is applied at a rate of 5% to the sum of TDC and Land for a 10- year loan, with 40% equity and payments at the end of the period.

biomass at 100-ha scale is €5.1 kg⁻¹, which is further reduced to €4.1 kg⁻¹ in the case of cultivation of a thermo-tolerant strain (without cooling).

$$\text{Cost B} = \text{Cost A} (\text{Size B/Size A})^{0.85} \quad (1)$$

In the case of a 1-ha plant deployed in a more suitable country (e.g. Tunisia), we have made the following assumptions: 1 - daily productivity remains at 15 g m⁻² land area d⁻¹ and the cultivation period is extended to 360 days per year, leading to an annual production of 54 tonnes ha⁻¹; 2 - total CAPEX do not change; 3 - OPEX increase from one side in relation to the longer cultivation period and the higher amount of biomass produced, but significantly decrease from the other side because labor cost per unit of personnel are halved [29] and electricity cost decreases to €0.08 kWh⁻¹ [29–30]. Given an annual productivity of 54 tonnes, total fixed capital per annum of €101,260 (same as in the base case in Tuscany) and total OPEX of €232,073, the biomass unit cost in Tunisia at 1-ha scale will be €6.2 kg⁻¹. If we use a thermo-tolerant strain the biomass cost will decrease to €5.4 kg⁻¹. Finally, in case of the 100-ha plant the biomass cost will be €3.2 and €2.6 kg⁻¹ with cooling and without cooling, respectively. The biomass cost in the different situations is shown in Table 11.

This TEA shows the relative contribution of the different factors to the final biomass cost and how they change with scale and location. The percent contribution to the final biomass cost of the main components (considering only the plant with cooling) in the different scenarios is reported in Table 12. The main costs of microalgae biomass production in Tuscany (base case) are labor (40% of total costs), capital

Table 7

Employees and workers needed to run the 1-ha GWP®-II plant and their relative costs.

	Annual cost (€)	Operators	Total cost (€)
Plant supervisor	52,000	1	52,000
Biologist	35,000	1	35,000
Worker (unskilled)	23,100	4	92,400
TOTAL			179,400

Table 8

Amount and cost of fertilizers required for the production of 36 tonnes (dry biomass) of *T. suecica*.

Fertilizer	Requirement (tonnes)	Cost (€ tonne ⁻¹)	Total cost (€)
NaNO ₃	15.3	400	6120
NaH ₂ PO ₄	1	1500	1500
TOTAL			7620

costs (23%), maintenance (15%) and electricity (8%). Any improvement that, besides increasing productivity, reduces the need of human resources (e.g. by means of higher automation) and CAPEX will have a profound impact on biomass production cost. At large scale (100 ha), the main cost becomes capital cost (39%), followed by maintenance (25%), electricity (18%), while labor represents only 8% of total costs. Thus at large scale the main objective should be reducing capital investment. Locating the plant in Tunisia halves the biomass production costs, increases the impact of capital cost (31%) and diminishes that of labor (27%). At large scale in Tunisia, the total biomass cost is halved again and the major cost remains capital (41%). Hence the importance of keeping capital cost low in this location, especially at large scale. In all the scenarios the sum of capital cost, maintenance, electricity and labor (a + b + c + d in Table 12) represents more than 85% of total costs.

6. Discussion

In the different commercial applications that involve microalgae, the influence of the cultivation system on biomass costs is generally considered to be a heavy one. The cost for building the GWP®-II photobioreactors (without ancillary equipment and piping but including manifolds) in the base case (1-ha) was about €55 m⁻², i.e. about 15% of tubular photobioreactor cost [12] and not very distant from the cost of lined ponds. A well-designed raceway pond, in fact, requires accurate land leveling and a weathering resistant liner, which covers the entire pond area, ending in an expense not far from €20 m⁻² [2,31]. When ancillary equipment and indirect capital costs are considered the capital expenses for the GWP®-II plant almost quadruple. However, it is worth noting that part of these machines and equipment will also be required in a raceway-based plant and, in the end, the installation costs of pond- and photobioreactor-based plants do not differ much [4,7]. In a recent TEA in which three technologies (panels, tubular reactors and ponds) were compared for two different locations (Spain and The Netherlands), flat panels allowed the lowest biomass production cost [4]. Our analysis shows that, with the GWP®-II technology, *T. suecica* F&M-M33 can be produced in Tuscany at €12.4 kg⁻¹. This cost is twice that reported by Norsker et al. [7] for a 1-ha panel-based plant in the Netherlands with an annual productivity of 64 tonnes per hectare. The two studies are however not comparable, since they differ widely in terms of contribution of the different cost factors and estimated productivity. Norsker et al. [7] foresee that biomass production cost may decrease to €0.7 kg⁻¹ at the 100-ha scale in optimized conditions (increased productivity, minimum mixing, free CO₂ and nutrients, suitable location). According to our analysis, algal biomass costs lower than €1 kg⁻¹ will not be attained in the near future in the absence of breakthroughs in strain characteristics (biological productivity) and cultivation technologies (engineering parameters). In a recent paper by Chauton et al. [4], in which similar conclusions are reported, panels are considered the design most susceptible to future optimization.

Production costs ranging from €0.4 to €25 kg⁻¹, depending on algal strain and assumptions, have been recently reported for microalgae produced at large scale (>1 ha) in closed systems [7,10,26]. The results of our analysis, which shows costs varying between €3.2 and €12.4 kg⁻¹ depending on scale and location, stand in this range. Much higher production costs were reported by Acien et al. [12] for the production of

Table 9
Electrical energy consumption and costs of machines necessary to operate the 1-ha GWP®-II plant.

Machinery	Hourly energy consumption (kWh)	Operation time (h y ⁻¹)	Annual energy consumption (kWh y ⁻¹)	Cost ^a (€)
Blowers (eight)			128,784	22,537
Day	30.0	2400	72,000	
Night	16.9	3360	56,784	
Pumps			62,851	10,999
Two 10-kW submersible pumps	15.0	1680	25,200	4410
One 5.5-kW centrifugal pump	4.5	480	2160	378
Two 0.75-kW centrifugal pumps	0.94	480	451	79
Eight 3.75-kW circulation pumps			35,040	6132
Cooling hours	16.0	1680	26,880	
No cooling period	2.0	4080	8160	
Centrifuges (two)	9.5	2400	22,800	3990
TOTAL			214,435	37,526

^a At €0.175 kWh⁻¹ [21] – The price is for industrial electricity and includes non-deductible taxes and levies. VAT is excluded.

Scenedesmus almeriensis, a freshwater microalga, in a small (420 m²) facility located in Southern Spain. The merit of the Spanish study is related to the fact that input data were derived from real equipment and utility costs without any approximation or extrapolation. The plant, based on ten 3-m³ tubular fence-type bioreactors, operates continuously along the year. Despite the very high productivity (3.8 tonnes y⁻¹, corresponding to 90 tonnes ha⁻¹ y⁻¹), the final biomass cost (after freeze drying) was €69 kg⁻¹. The main causes of this high cost were very high labor (51.6% of the total) and capital (42.6% of the total) expenses. Total CAPEX in this plant surpassed €1000,000, despite its small size. According to Acien et al. [12] by optimizing the process (reduction of personnel to one man per hectare, removal of freeze drying plus other simplifications) and scaling up production to 200 tonnes y⁻¹ (which will require an area of 2.2 ha) a production cost of €12.6 kg⁻¹ can be achieved. Our study shows that the same cost per unit biomass can be attained in Tuscany in the 1-ha GWP®-II plant despite the lower productivity. This positive result of our study is mainly due to the simplified design and lower cost of the GWP®-II plant in comparison with the tubular system used in Spain.

7. Conclusions

Using conservative assumptions we estimated a cost of algal biomass production at 100-ha scale of about €5 kg⁻¹ in Tuscany and €3 kg⁻¹ in more suitable countries. Given the peculiar biochemical composition of some marine microalgae that are rich in pigments, active molecules, polyunsaturated fatty acids and minerals, this TEA confirms that microalgal technologies have high commercial potential not only for high-value (e.g. cosmetics and aquaculture), but also for medium- and low-value products (e.g. fortified and nutritional foods). With soybean at less than €0.35 kg⁻¹ and wheat and maize at less than €0.2 kg⁻¹

Table 10
Direct and indirect (maintenance, overhead and administration) operating costs (OPEX) for the 1-ha GWP®-II plant.

	Annual cost (€)
DIRECT OPERATING COSTS	
Labor	179,400
Fertilizers	7620
Electricity	37,526
Consumables	6980
Total direct operating costs (TDO)	231,526
INDIRECT OPERATING COSTS	
Maintenance (5% of TDC)	67,275
Overhead (10% of TDO)	23,153
Administration (10% of TDO)	23,153
Total indirect operating costs	113,581
TOTAL OPEX	345,107

TDC: total direct capital; TDO: total direct operating costs.

[32], the production of algal biofuels, protein, food and feed seems currently out of reach. However, the global scenario of agriculture commodities is rapidly changing and other factors, besides a pure economic evaluation, will assume greater importance and rise public concern in the future [33]. These include the use of non-renewable resources, such as soil and freshwater, the impact on the environment and on human health, social and political implications. A fair comparison of algal and agricultural techniques used in the production of our most needed commodities (food, feed, biofuels) will require a correct evaluation through reliable LCAs of the negative externalities of both traditional crops and large-scale algal cultures.

8. Definitions

Plant (in the present study): all the equipment, photobioreactors, machines, buildings, instruments, controls and services necessary for the production of algal biomass. In the present study the plant occupies a total area of 1-ha and is composed of eight GWP®-II modules.

GWP® photobioreactor: disposable flat-shaped closed cultivation system called Green Wall Panel.

GWP® module: an autonomous production unit representing 1/8 of the 1-ha production area. It includes twenty-four 48-m long GWP®, piping and instrumentation necessary for its operation. Each module is hydraulically independent from the other. It does not include machines and services (like centrifuges, submersible pumps and PLC control system), which are common to the whole plant.

Panel: the LDPE culture chamber, where the photosynthetic process occurs, and its enclosing framework with air bubbling pipe and valves.

Conflict of interest

M.R. Tredici, L. Rodolfi, N. Bassi, and G. Sampietro have a financial interest in F&MS.r.l.

Table 11
Cost of *T. suecica* biomass produced in a GWP®-II plant in Tuscany and Tunisia at 1- and 100-ha scale.

	Tuscany (€ kg ⁻¹)	Tunisia (€ kg ⁻¹)
1-ha scale		
with cooling	12.4	6.2
without cooling	11.1	5.4
100-ha scale		
with cooling	5.1	3.2
without cooling	4.1	2.6

Table 12

Main costs for producing *T. suecica* biomass in a GWP®-II plant in the two different locations at 1-and 100-ha scale. In brackets % of total biomass cost.

	Tuscany	Tunisia
	€ kg ⁻¹	€ kg ⁻¹
1-ha scale		
Total cost	12.4	6.2
a - Total fixed capital cost per annum	2.8 (23%)	1.9 (31%)
b - Maintenance	1.9 (15%)	1.2 (19%)
c - Labor	5.0 (40%)	1.7 (27%)
d - Electricity	1.0 (8%)	0.5 (8%)
a + b + c + d	10.7 (86%)	5.3 (85%)
100-ha scale		
Total cost	5.1	3.2
a - Total fixed capital cost per annum	2.0 (39%)	1.3 (41%)
b - Maintenance	1.3 (25%)	0.9 (28%)
c - Labor	0.4 (8%)	0.1 (3%)
d - Electricity	0.9 (18%)	0.4 (13%)
a + b + c + d	4.6 (90%)	2.7 (85%)

Acknowledgements

We gratefully acknowledge inputs and assistance from Jennifer Markham of the United States National Renewable Energy Laboratory (NREL). Part of the research activity here reported has been funded by the EU FP7 project BIOFAT, Contract Number FP7-268211 and part by the University of Florence and Fotosintetica & Microbiologica S.r.l.

References

- [1] G. Chini Zittelli, N. Biondi, L. Rodolfi, M.R. Tredici, Photobioreactors for mass production of microalgae, in: A. Richmond, Q. Hu (Eds.), *Handbook of Microalgal Culture: Applied Phycology and Biotechnology*, Second ed Wiley 2013, pp. 225–266, <http://dx.doi.org/10.1002/9781118567166.ch13>.
- [2] M.R. Tredici, Mass production of microalgae: photobioreactors, in: A. Richmond (Ed.), *Handbook of Microalgal Culture: Biotechnology and Applied Phycology*, Blackwell Science 2004, pp. 178–214.
- [3] M.R. Tredici, Photobiology of microalgae mass cultures, *Biofuels* 1 (2010) 143–162, <http://dx.doi.org/10.4155/bfs.09.10>.
- [4] M.S. Chauton, K.I. Reitan, N.H. Norsker, R. Tveterås, H.T. Kleivdal, A techno-economic analysis of industrial production of marine microalgae as a source of EPA and DHA-rich raw material for aquafeed: research challenges and possibilities, *Aquaculture* 436 (2015) 95–103, <http://dx.doi.org/10.1016/j.aquaculture.2014.10.038>.
- [5] R. Davis, A. Aden, P.T. Pienkos, Techno-economic analysis of autotrophic microalgae for fuel production, *Appl. Energy* 88 (2011) 3524–3531, <http://dx.doi.org/10.1016/j.apenergy.2011.04.018>.
- [6] T.J. Lundquist, I.C. Woertz, N.W.T. Quinn, J.R. Benemann, A Realistic Technology and Engineering Assessment of Algae Biofuel Production. Energy Biosciences Institute, University of California, Berkeley, 2010, pp.1–178.
- [7] N-H. Norsker, M.J. Barbosa, M.H. Vermuë, R.H. Wijffels, Microalgal production—a close look at the economics. *Biotechnol. Adv.* 29 (2011) 24–27. doi:<http://dx.doi.org/10.1016/j.biotechadv.2010.08.005>
- [8] J.W. Richardson, M.D. Johnson, J.L. Outlaw, Economic comparison of open pond raceways to photo bio-reactors for profitable production of algae for transportation fuels in the Southwest, *Algal Res.* 1 (2012) 93–100, <http://dx.doi.org/10.1016/j.algal.2012.04.001>.
- [9] R. Slade, A. Bauen, Micro-algae cultivation for biofuels: cost, energy balance, environmental impacts and future prospects, *Biomass Bioenergy* 53 (2013) 29–38, <http://dx.doi.org/10.1016/j.biombioe.2012.12.019>.
- [10] P.J.L.B. Williams, L.M. Laurens, Microalgae as biodiesel & biomass feedstocks: review & analysis of the biochemistry, energetics & economics, *Energy Environ. Sci.* 3 (2010) 554–590, <http://dx.doi.org/10.1039/B924978H>.

- [11] M.E. Huntley, D.G. Redalje, CO₂ mitigation and renewable oil from photosynthetic microbes: a new appraisal, *Mitig. Adapt. Strateg. Glob. Chang.* 12 (2007) 573–608, <http://dx.doi.org/10.1007/s11027-006-7304-1>.
- [12] F.G. Acien, J.M. Fernández, J.J. Magán, E. Molina, Production cost of a real microalgae production plant and strategies to reduce it, *Biotechnol. Adv.* 30 (2012) 1344–1353, <http://dx.doi.org/10.1016/j.biotechadv.2012.02.005>.
- [13] G. Benvenuti, Batch and Repeated-Batch Oil Production by Microalgae PhD Thesis Wageningen University, 2016.
- [14] M.R. Tredici, N. Bassi, M. Prussi, N. Biondi, L. Rodolfi, G. Chini Zittelli, G. Sampietro, Energy balance of algae biomass production in a 1-ha "Green Wall Panel" plant: how to produce algae biomass in a closed reactor achieving a high Net Energy Ratio, *Appl. Energy* 154 (2015) 1103–1111, <http://dx.doi.org/10.1016/j.apenergy.2015.01.086>.
- [15] M.R. Tredici, L. Rodolfi, Reactor for industrial culture of photosynthetic micro-organisms. Patent WO2004/074423 A2 (to Università degli Studi di Firenze).
- [16] L. Rodolfi, G. Chini Zittelli, N. Bassi, G. Padovani, N. Biondi, G. Bonini, M.R. Tredici, Microalgae for oil: strain selection, induction of lipid synthesis and outdoor mass cultivation in a low-cost photobioreactor, *Biotechnol. Bioeng.* 102 (2009) 100–112, <http://dx.doi.org/10.1002/bit.22033>.
- [17] M.R. Tredici, L. Rodolfi, G. Sampietro, N. Bassi, Low-cost photobioreactor for microalgae cultivation. Patent WO2011/013104 A1 (to Fotosintetica & Microbiologica S.r.l.).
- [18] A. Guccione, N. Biondi, G. Sampietro, L. Rodolfi, N. Bassi, M.R. Tredici, *Chlorella* for protein and biofuels: from strain selection to outdoor cultivation in a Green Wall Panel photobioreactor, *Biotechnol. Biofuels* 7 (2014) 84, <http://dx.doi.org/10.1186/1754-6834-7-84>.
- [19] M.S. Peters, K.D. Timmerhaus, *Plant Design and Economics for Chemical Engineers*, Fourth ed McGraw-Hill, New York, 1991 1–910.
- [20] Regione Toscana, Guida ai costi di impresa, Invest in Tuscany, 2016 1–55.
- [21] EUROSTAT, EUROSTAT Statistics Explained: Energy Price Statistics, http://ec.europa.eu/eurostat/statistics-explained/index.php/Energy_price_statistics2014 accessed 24/02/2016.
- [22] F. Abiusi, G. Sampietro, G. Marturano, N. Biondi, L. Rodolfi, M. D'Ottavio, M.R. Tredici, Growth, photosynthetic efficiency, and biochemical composition of *Tetraselmis suecica* F&M-M33 grown with LEDs of different colors, *Biotechnol. Bioeng.* 111 (2014) 956–964, <http://dx.doi.org/10.1002/bit.25014>.
- [23] M.R. Tredici, N. Biondi, E. Ponis, G.C. Zittelli, L. Rodolfi, Advances in microalgal culture for aquaculture feed and other uses, in: G. Burnell, G. Allan (Eds.), *New Technologies in Aquaculture: Improving Production Efficiency, Quality and Environmental Management*, Woodhead Publishing 2009, pp. 610–676.
- [24] P. Pertile, L. Zanella, M. Herrmann, H. Joppe, S. Gaebler, Extracts of *Tetraselmis* sp. Patent US2010/0143267 A1 (to SYMRISE GmbH & Co. KG).
- [25] F. Kreith, J.F. Kreider, *Principles of Solar Engineering*, Hemisphere Publishing Corporation, Washington D.C., 1978 37–82.
- [26] M.A. Borowitzka, Techno-economic modeling for biofuels from microalgae, in: M.A. Borowitzka, N.R. Moheimani (Eds.), *Algae for Biofuels and Energy*, Developments in Applied Phycology 5, Springer 2013, pp. 255–264.
- [27] D. Chung, C. Davidson, R. Fu, K. Ardani, R. Margolis, U.S. photovoltaic prices and cost breakdowns: Q1 2015 benchmarks for residential, commercial, and utility-scale systems, Technical Report NREL/TP-6A20-64746, National Renewable Energy Laboratory, Golden 2015, pp. 1–51.
- [28] Conergy, La "grid parity": nel 2015 in Italia il fotovoltaico costerà come l'energia elettrica di rete, <http://www.conergy.it/grid-parity-nel-2015-in-italia-fotovoltaico-costera-come-lenergia-elettrica-rete/2011> accessed 16/02/16.
- [29] Assocamerestero, Business Atlas, Tunisia, <http://www.assocamerestero.it/default.asp?idtema=1&idtemacat=1&page=informazioni&action=readall&index=1&idcategoria=351932015> accessed 24/02/2016.
- [30] STEG, Les tarifs de l'électricité, https://www.steg.com.tn/fr/clients_ind/tarifs_ht.html2014 accessed 14/03/2016.
- [31] R. Davis, J. Markham, C. Kinchin, N. Grundl, E.C.D. Tan, D. Humbird, Process design and economics for the production of algal biomass: Algal biomass production in open pond systems and processing through dewatering for downstream conversion, Technical Report NREL/TP-5100-64772, National Renewable Energy Laboratory, Golden 2016, pp. 1–119.
- [32] EC. Commodity Price Dashboard No. 43-December 2015 edition. http://ec.europa.eu/agriculture/markets-and-prices/price-monitoring/dashboard/food12-2015_en.pdf (accessed 27/02/2016)
- [33] M.R. Tredici, The Food Island: How can microalgae contribute to Bioeconomy in Europe? Conference on "Sustainable Agriculture, Forestry and Fisheries in the Bioeconomy - A Challenge for Europe", 8 October 2015, Brussels (Belgium).