



Universidade do Minho  
Escola de Engenharia



International Masonry Society

---

## 9<sup>th</sup> International Masonry Conference 2014 in Guimarães

---

# Stability and Stiffness Contribution of the masonry in the Borbone Anti-seismic System

GALASSI, STEFANO<sup>1</sup>; RUGGIERI, NICOLA<sup>2</sup>; TEMPESTA, GIACOMO<sup>3</sup>; ZINNO, RAFFAELE<sup>4</sup>;

**ABSTRACT:** The Borbone construction system, comprises of masonry panels reinforced within a timber frame, originated in the Calabria region at the end of '700. The buildings with such anti-seismic technology have been subjected to general checks after the 1905 and 1908 catastrophic earthquakes, showed high resistance to the dynamic actions. This ductile behaviour was witnessed by several historical photos and by important scholars of the time. The system represents the synthesis of the scientific knowledge on the anti-seismic engineering of the XVIII C, in which the masonry confers stiffness to the timber frames and contemporaneously it dissipates seismic energy through the friction generated among the component elements. The timber structure role is to limit or to make reversible the displacements generated in the masonry mass in case of seismic acceleration.

The outcome of cycling testing of full-scale specimens [1], performed at CNR Ivalsa in Trento<sup>5</sup>, supported by calculations enabled using prediction models will be presented and discussed in the paper. The experimental results will be related to historical photos of the in plane and out of plane earthquake damages of the masonry reinforced with timber frames.

**Keywords:** Seismic behaviour, masonry reinforced, timber frames, out-of-plane, stiffness

## 1 INTRODUCTION

The Borbone compound system, constituted by masonry braced with timber frames, was born after the earthquake that struck the Calabria region in 1783 [2]. Ferdinando the IV<sup>th</sup> of Borbone, in response to the catastrophe, drew up, among other initiatives, the first anti-seismic code of Europe, in which the technicians were obliged to reconstruct with masonry reinforced with «...*con ossatura di grossitravi ... legati con altritravitraversali*...»<sup>6</sup>, but providing no other indications of construction

<sup>1</sup>Ph.D., University of Florence, DiDA, stefano.galassi@unifi.it

<sup>2</sup>Architect, University of Calabria, Dimes, nicola.ruggieri@unical.it

<sup>3</sup>Professor, University of Florence, DiDA, giacomo.tempesta@unifi.it

<sup>4</sup>Professor, University of Calabria, Dimes, raffaele.zinno@unical.it

<sup>5</sup>In September 2013, cyclic tests on full scale casa baraccata specimens were performed at the CNR Ivalsa in Trento, as a result of a research developed by University of Calabria (Ruggieri, N.; Zinno, R.) and CNR Ivalsa (Ceccotti, A.; Polastri, A.).

The experimental campaign included two tests performed on timber frames with and without masonry infill. The reversed loading procedure, according to UNI 12512, was characterized by a max displacement of 80 mm (2.6% drift) to which corresponded a force, relative to pushing direction, of -101,62 kN, coincident with  $F_u$ . Concerning the positive direction ("tension") a  $F_{max}$  of 103 kN and a  $F_u$  of about 100 kN, was achieved, respectively for a slip of 60mm and 80 mm. The sample showed a ductility of 7.6 (positive direction) and a EVDR variable between 6% and 8%. The envelope curve exhibited a non-linear behaviour of the specimen (infill frame), characterized by a quite fat loop and a large amount of dissipated energy (i.e. 1579 KNmm corresponding to 80 mm in pulling).

Look at Ruggieri, N.; Zinno, R.: Behaviour of the Borbone Constructive System under Cyclic Loading. Preliminary Report, in proceedings of 1st International Conference on *Historic Earthquake-Resistant Timber Frames in the Mediterranean Area*, 2013; ed. Ruggieri N.; Tampone G.; Zinno R. - in press.

<sup>6</sup>«...with big members skeleton ...bonded with other transversal members...».

details or any drawings. The system was defined as *casa baraccata* in the XIX<sup>th</sup> C. It represents the synthesis of the most advanced inventions and discoveries of anti-seismic engineering of the XVIII<sup>th</sup> C., and were the culmination of a thousand-year-old construction system in the Calabria region [3].

The Borbone system was developed in a variety of ways during the reconstruction after earthquakes, characterized by different arrangements of the timber frames and by diverse geometric dimensions of the members (Figure 1). In fact, some examples present in the Calabria region are characterized by Saint Andrew wooden crosses, other types in which the stiffness to in plane action is provided by only the masonry infill. Other *baraccati* edifices exhibit a double timber framing suitably bonded through transverse members. Among possible variations around the "*ossatura di grossitravi*", the location down the wall of the timber frames inside the masonry wall varied and in some cases, the wall was made out of more than one leaf. These if not properly bonded by means of lateral elements, usually stone, are vulnerable under seismic action perpendicular to the wall, with possible overturning of the outer leaf even under low and moderate earthquake conditions.



**Figure 1.** Different types of timber frame arrangement. The framing is placed in the internal (on the left) and in the external part of the wall on the right.

## 2 EVALUATION OF OUT-OF-PLANE STABILITY

Façade out-of-plane collapse in old constructions is a crucial issue, nevertheless few studies are present in the scientific literature (Figure 2).

The rocking mechanism of a wall subject to an horizontal action was properly seen by Rondelet with a qualitative analyses of the failures occurred to a block-work with different boundary conditions, either an isolated panel or one connected to the orthogonal ones. Giuffrè [4] and Como [5] were interested in this kind of rigid body motion and in particular in the overturning of a wall constituted by two leaves, in which it was demonstrated there was a high reduction of the panel resistance to horizontal lateral action. Several out-of-plane collapse mechanisms were defined and collected in a database (FaMIVE) with the aim to obtain a procedure for the assessment of seismic vulnerability of historic construction [6]. Other research has carried out by D'Ayala [7] concerning the analysis of the so-called box behaviour in an historic building and the constraining action represented by quoins and consequently by the orthogonal wall, calculating the friction contribution triggered during the overturning mechanism. Furthermore considerations are present about the Vivencio's model, a constructive system constituted by a couple of timber frames inside the

masonry, emphasizing the important role of the joints and the building corner, the latter characterized by an explicit strengthening with 4 wooden posts, to achieve a proper configuration under out-of-plane actions. Doherty et al. [8] have presented a dynamic analysis of the out-of-plane behaviour of unreinforced masonry walls validated by an experimental campaign on panels only restrained at the upper edge. Based on these investigations, a tri-linear simplified model to reproduce the load-displacement graph is introduced, in which is described a linear branch, with constant stiffness, then the crack occurred, represented by an horizontal branch, which generates a cylindrical hinge in the mid part of the wall, finally the motion starts and the wall behaves as a set of rigid bodies.



**Figure 2.** Seminara (Rc), 1908 earthquake; Palmi (Rc), 1908 earthquake. Overturning of the outer part of the wall, in *baraccato* buildings.

An analysis on typical failures has been carried out by the University of Calabria, based on historic photos and chronicles depicting masonry buildings reinforced with timber frames after the earthquakes of 1905 and 1908. This research has demonstrated proper behaviour of the Borbone constructive system under seismic action and in general negligible damages, limited to the partial overturning of part of the wall [9]. This kind of failure is strictly linked to the fabric features; in fact the *Baraccata* masonry type, characterized by the lack of transversal connection stones, does not ensure a monolithic behaviour of the wall with a consequent vulnerability to out-of-plane collapse even with low intensity earthquakes. The moment equilibrium, between the overturning tendency due to the seismic excitation and the stabilizing moment generated by the friction effect and the geometrical properties of the too thin leaf, means stability is not maintained.

In this case the unique way to try to withstand overturning is by means of a large thickness of the masonry wall, with the aim to improve the weight and counteract the out-of-plane motion generated by the equivalent horizontal force. It is worth noting that if the wall does not have effective through thickness connections, the high deformability of the timber frame generates an additional push outward and obviously an impairment of the out-of-plane response of the external masonry leaf.

Namely:

$$M_s = f(W, \theta, B) \quad (1)$$



$$M_o = f(\alpha W, 1/K) \quad (2)$$

Hence the panel masonry stability is ruled by friction phenomena ( $\theta$ ) strictly linked to the geometry and the weight of the wall ( $W$ ). Further, the boundary conditions ( $B$ ), quoins, floor, roof and intersecting walls are of fundamental importance and other constraining forces are given by the possible presence of overburden even if it is difficult to predict. Whilst the overturning moment ( $M_o$ ) is a function of the intensity of the earthquake input and of the geometrical and weight features of the wall ( $\alpha W$ ); in addition the overturning force is amplified by the presence of the timber flexibility given by the value of the flexural deformability ( $1/K$ ). The latter is computable taking into account that the timber frame post is characterized by a free rotation at the base node, whilst the header restraint is represented by a double pendulum given by an half lap joint, omitting the intermediate restraints realized by horizontal wooden members that are characterized by an ineffective node for horizontal action with outward direction<sup>7</sup> (unilateral behaviour). This represents a stable static scheme in which equilibrium is ensured by the masonry (Figure 3).

The above static analysis is independent from seismic vertical component and from the wall interaction with the ground.

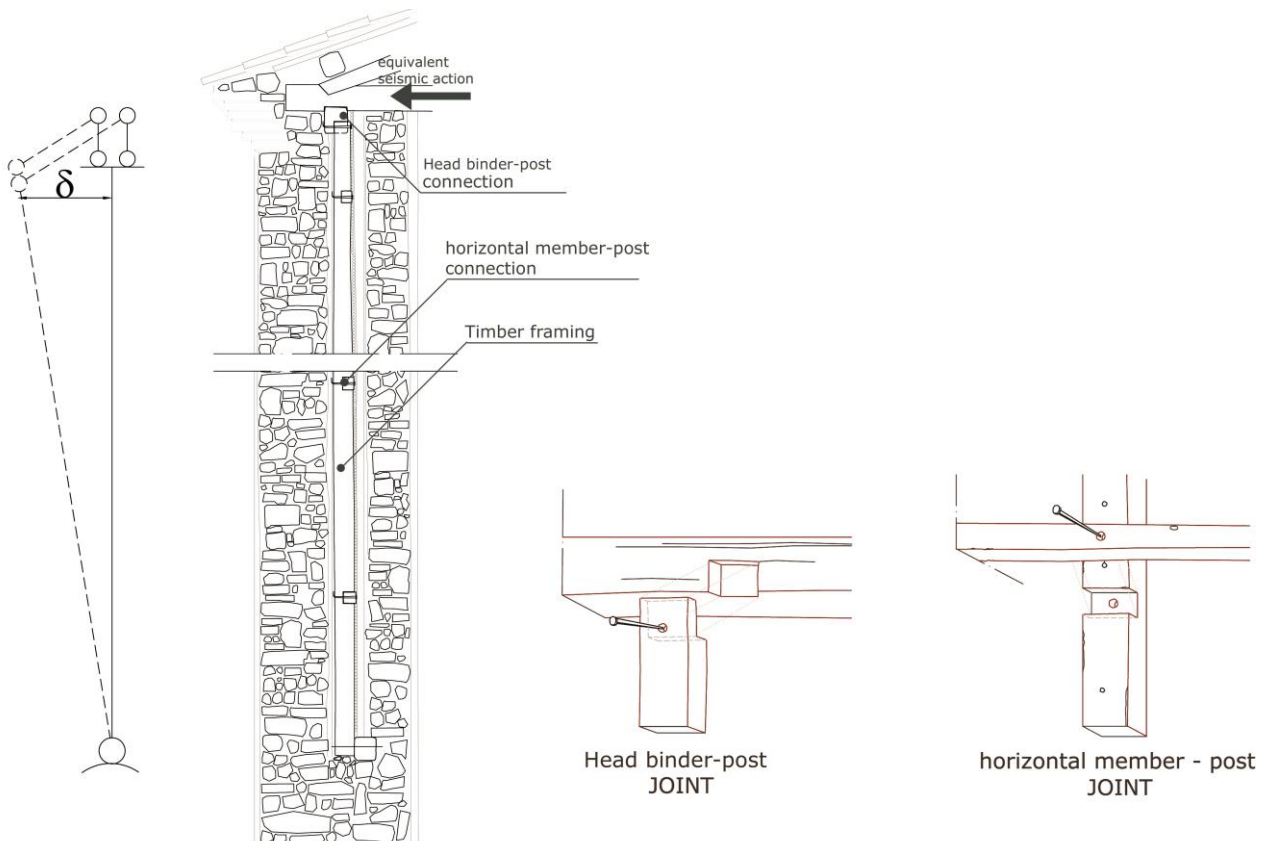

**Figure 3.** Static scheme with internal timber framing, showing cross-section and joint details of a *baraccato* constructive system in Mileto (Vv)

Other *Baraccato* constructive system types are characterized by the presence of sufficient and effective transverse elements that enable the wall to act in a monolithic mode, together with the

<sup>7</sup>In fact the horizontal timber elements of the frame are superposed to the post and fastened by means of a pyramidal nail; this arrangement, relatively to an horizontal force with an outward direction, doesn't allow the transmission of stresses and it is un-effective to constraint horizontal displacements of the post.

internal timber framing. In this case, with a force based approach, the stabilizing moment benefits from the contribution given by the flexural rigidity ( $K$ ) of the wooden frame, internal to the masonry.

In other words:

$$M_s = f(W, \theta, B, K) \quad (3)$$

Moreover, it is worth emphasizing that for the monolithic *baraccato* wall, thanks to the presence of timber framing the formation of an internal cylindrical hinge under overturning action, is unlikely.

### 3 A FIRST APPROACH TO THE NUMERICAL MODELLING

The mechanical interpretation of structural behaviour of a masonry wall reinforced with timber frames can be conducted through the adaptation, to such a case, of the original software *BrikWORK*<sup>8</sup>, specifically developed by some of the authors for the analysis of general masonry structures [10, 11, 12].

In the original numerical model, the masonry is modelled as a collection of rigid elements (bricks or stones) connected by mortar joints, where the elastic-brittle behaviour of the material is concentrated. Consequently, the main type of damage mechanism considered in the mortar joints is a tensile failure: until such a failure happens, the joints are assumed to retain an elastic behaviour.

Such an approach therefore involves that the masonry, as a whole, has a good capability to carry compression loads and, taking into account that the masonry to which we want to refer is that of historical architecture heritage, the tensile strength of the material is limited due to the poor cohesion between mortar and bricks.

Under these assumptions, the mechanical characterization of masonry refers to a system of rigid blocks connected by unilateral contact and frictional links (Figure 4).

In the numerical model the contact devices located in the joints are described by a set of fictitious links, arranged orthogonal to the interface surfaces, capable of transmitting only compressive forces or, at most, weak tensile forces which do not exceed the assigned limit values, and, by an additional link, tangent to the interface surface, to transmit the shear force. In the case of brittle-rigid joints only two normal links are strictly necessary.

In the case of elastic-cracking joints it is better to consider at least four normal links in order to highlight the actual cracking pattern with the possibility of measuring the width and depth of the cracks inside the mortar joints.

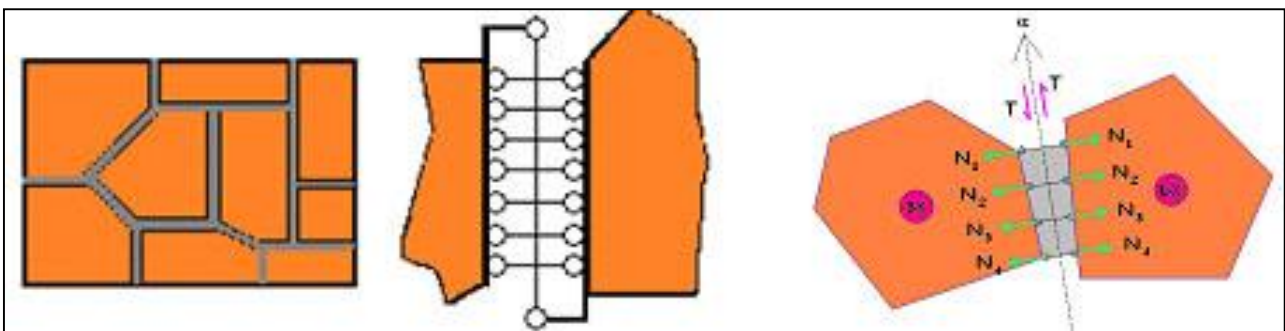
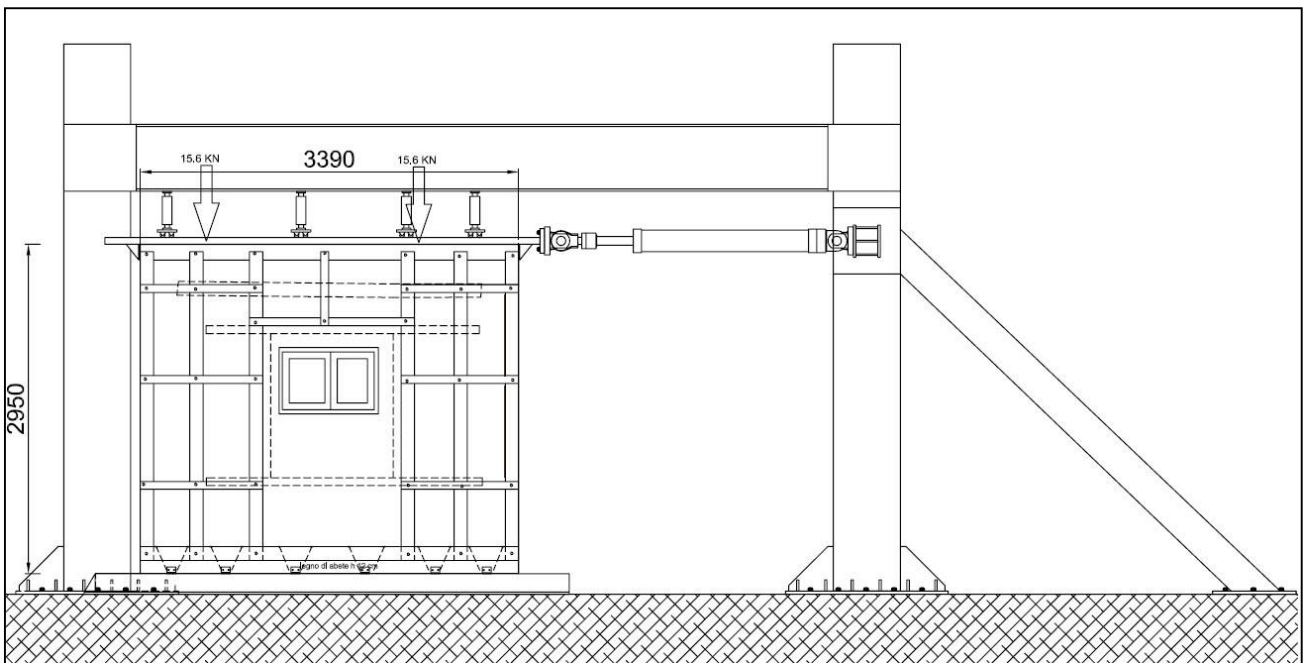

**Figure 4.** Discrete model of joint interface between blocks of stones

<sup>8</sup>*BrikWork* is a specifically updated *realise* of a version previously defined in the context of research on the behavior of masonry structures (Galassi, Paradiso, Tempesta – Dep. of Architecture DiDa – Section of “Materials and Structures”).

Moreover it is reasonable to think that a model which considers the rigid blocks linked together by means of deformable surfaces, with no tension behaviour, is the most correct model to interpret the influences which the dimensions of the blocks and the joints' orientation have on the behaviour of historical masonry buildings. Such a model is also capable to describe very clearly the progression of the damage of masonry under loading.

The appropriate adaptation of the original numerical model to the one used for the analysis of the masonry wall reinforced with timber frames, has necessarily had to take account of the specific definition of the contact joint between wood and stone, which has been considered of the type perfectly no-tension, and the contact joint between wood and wood, in its turn considered perfectly elastic.



**Figure 5.** Full-scale specimen of a masonry wall reinforced with timber frames made on the basis of the Borbone constructive system. Laboratories Ivalsa – CNR.

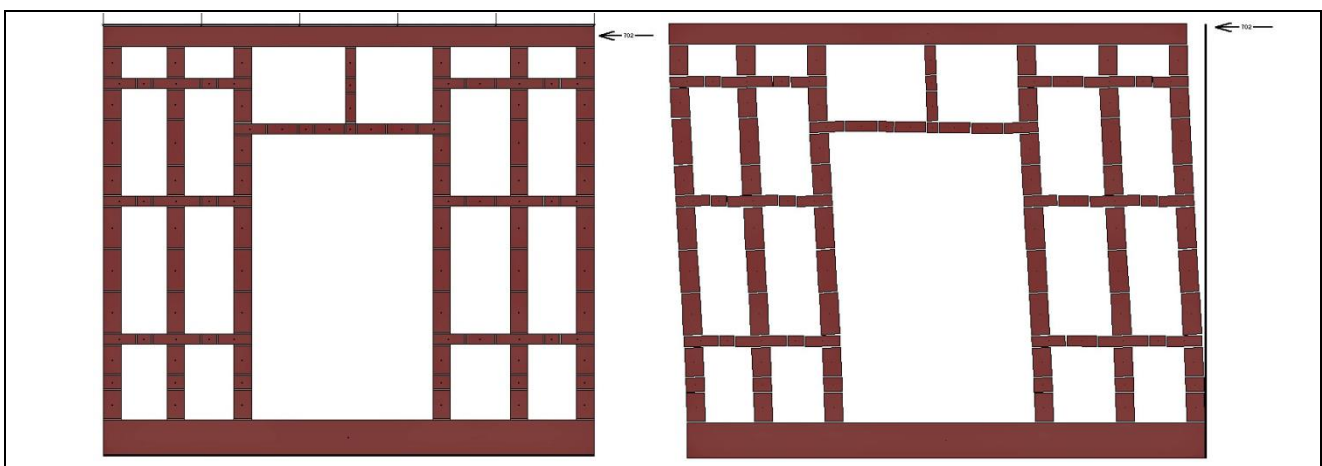

**Figure 6.** Modelling of the timber frame specimen.

For calibration, the mechanical parameters to be assigned to the contact joints between the finite elements constituting the general mesh of the model, were obtained from the experimental tests performed (Figure 5), at the laboratories Ivalsa – CNR, on a full-scale specimen of a masonry wall made on the basis of the Borbone constructive system (Figure 6).

In the first place the mechanical and geometrical characteristics have been assigned, at the joints of the interface, to the discretized model so as to reproduce the same field of deformation and displacements obtained by the experimental tests carried out on the single timber frame.

Taking into account the actual behaviour of the experimental model (Figure 7) in which even for the maximum value of the applied load the timber frame has never failed in any section, the limits of resistance in the contact joints have been conventionally assumed equal to infinity for both tensile and compressive interactions.

Hence, the discretized model of the masonry infill was defined, taking into account the shape and the arrangement of the stone elements to reproduce, as closely as possible, with regard to the thickness of the joints, the reality of the experimental model.

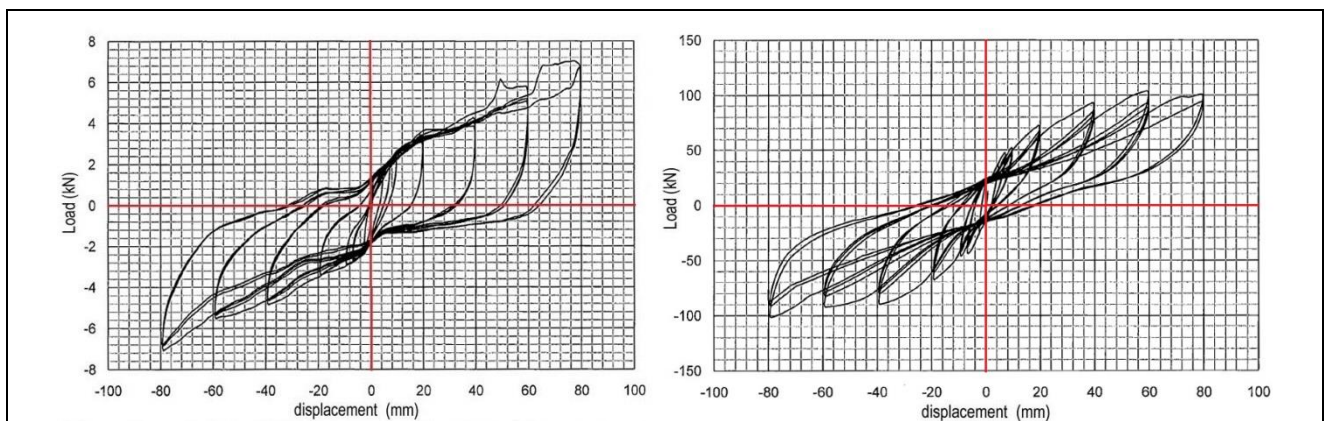

**Figure 7.** Hysteresis loops from the tests. Single timber frame and masonry wall reinforced with timber frame.

For the mechanical characteristics of the contact joints between stone and wood a limit of tensile strength of zero has been assumed, while for the contact joints between the stones an ultimate tensile strength equal to 0.5 MPa has been considered.

With regard to the boundary conditions of the mechanical model subjected to the numerical analysis, taking into account the choices made for the experimental tests, fixed supports have been assumed at the base and movable hinges at the top (Figure 8).

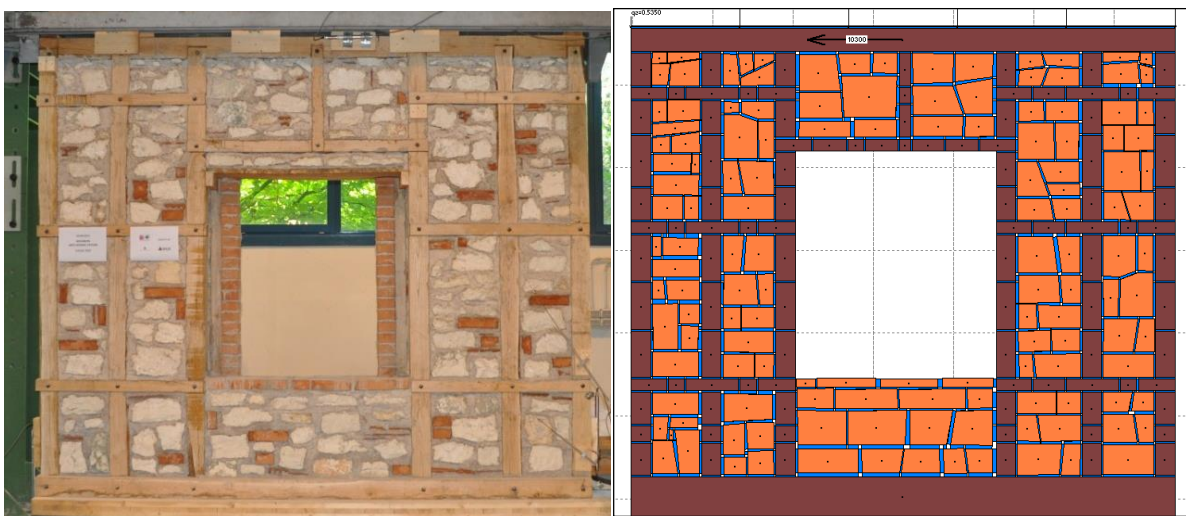

**Figure 8.** Mechanical modelling of the masonry wall made on the basis of the Borbone constructive system.



The results obtained with the numerical modelling have provided an interpretation of the behaviour of the wall very close, both quantitatively and qualitatively, to that of the experimental model.

The final results for a load applied at the top equal of 103,64 kN were achieved after 311 iterative steps of the calculation algorithm with a final horizontal displacement, measured at the top of the specimen, equal to 59,90 mm, very close to the actual one.

It is interesting to notice how, in terms of fracture and detachment, the crack pattern produced as the output of numerical analysis has shown a significant similarity with the real one (Figure 9).



**Figure 9.** Ultimate deformed shape and cracking pattern. Comparison between experimental test and numerical modelling.

#### 4 CONCLUSION

The above document describes two peculiar aspects of the seismic behaviour of the *Baraccato* constructive system: its tendency to overturning of the external leaf masonry and the good response under in plane actions.

This compound system, with data relying on historical documents, never showed any cases of overturning of the entire wall, during the catastrophic earthquake events of 1905 and 1908. In fact the failures were limited, relative to earthquake perpendicular to the panel, exclusively to the external leaf, which was too thin and devoid of through connection elements with the other leaves of the wall.

Furthermore the mechanical interpretation, conducted by means the adaptation of the original software *BrikWORK*, has analysed, with a preliminary numerical approach, the in plane behaviour of the Borbone system based on the cyclic tests outcomes.

#### ACKNOWLEDGEMENTS

The 2<sup>nd</sup> and the 4<sup>th</sup> author wish to thank Regione Calabria for the economical support to realize the experimental campaign.



**REFERENCES**

- [1] Ruggieri, N.; Zinno, R.: Behaviour of the Borbone Constructive System under Cyclic Loading. Preliminary Report, in proceedings of *1st International Conference on Historic Earthquake-Resistant Timber Frames in the Mediterranean Area, 2013*; ed. Ruggieri N.; Tampone G.; Zinno R.- in press.
- [2] Ruggieri, N.: La casa antisismica, in *Proc. of the International Conference of Historic Wooden Structures*: Tampone ed.: Florence2005, 141-146.
- [3] Ruggieri, N.: Il sistema antisismico borbonico, muratura con intelaiatura lignea, genesi e sviluppo in Calabria alla fine del '700. *Bollettino degli Ingegneri*, 10 (2013).
- [4] Giuffrè, A.: *Lettura sulla Meccanica delle Murature Storiche*: Edizioni Kappa: Roma 1991.
- [5] Como, M.: *Statica delle costruzioni storiche in muratura*: Aracne Editrice: Roma 2011.
- [6] D'Ayala, D; Speranza, E.: An Integrated Procedure for the Assessment of Seismic Vulnerability of Historic Buildings: *Proc. 12<sup>th</sup> European Conference on Earthquake Engineering*: Published by Elsevier Science Ltd 2003.
- [7] D'Ayala, D.: The Role of Connections in the Seismic Resilience of Historic Masonry Structures. In: *Proc. ANIDIS*: Bari2011.
- [8] Doherty, K.; Griffith, M.C.; Lam, N.; Wilson, J.: Displacement-based Seismic Analysis for Out-of-plane Bending of Unreinforced Masonry Wall: *Earthquake Engineering and Structural Dynamics*, 31 (2002), 833-850.
- [9] Ruggieri, N.; Tampone, G.; Zinno, R.: Typical Failures, Seismic Behaviour and Safety of the "Bourbon system" with Timber Framing: *Advanced Material Research, vol. 778*: Trans Tech Publication: Switzerland 2013, 58-65.
- [10] Galassi, S; Paradiso, M; Tempesta, G; Zerboni, D.: The Medieval Bridge over the Rignalla Brook near Florence: Analysis and Rehabilitation Project, *Int. Journal EDA – Esempi di Architettura* (2013)
- [11] Galassi, S; Paradiso, M; Tempesta, G.: X-Vaults: a Software for the Analysis of the Stability of Masonry Cross-Vaults, *J. Computer Science Issues* 9,2,2 (2012) 133-142.
- [12] Galassi, S; Paradiso, M; Tempesta, G.: Non linear analysis of masonry structures subjected to external settlements, *Open J. Civil Eng.* 3,2A (2013) 18-26.