

Third International Conference on Applied Energy - 16-18 May 2011 - Perugia, Italy
David Chiaramonti, Andrea Maria Rizzo, Giovanni Riccio, Alessandro Cappelletti, Matteo Prussi, Francesco Martelli
Adaptation of a micro gas turbine to biofuels and preliminary tests
pages nn-mm

Adaptation of a micro gas turbine to biofuels and preliminary tests with diesel fuel

David CHIARAMONTI, Andrea Maria RIZZO, Giovanni RICCIO, Alessandro CAPPELLETTI, Matteo PRUSSI, Francesco MARTELLI

CREAR, University of Florence and RE-CORD
via Santa Marta 3, Florence (Italy)

Abstract

A Garrett GTP 30-67 micro gas turbine (25 kW electrical power) has been installed and modified at CREAR/RE-CORD facilities to allow testing with several alternative biofuels like biodiesel, pure vegetable oil and bio oil from fast pyrolysis. The MGT performances have been initially characterised with diesel oil. The modifications involved the substitution of fuel line piping and connections, sealing material and other components to withstand both increased aggressiveness and higher viscosity of biofuels, and to deal with the different physical and chemical properties of alternative fuels, such as spraying, atomization, and combustion behaviour and stoichiometric air of combustion. The engine has been instrumented for direct measurement of pressure, temperature, fuel flowrate and exhaust's gas concentration (i.e. CO, CO₂, total NO_x and NO, O₂). An in-house indirect measurement of compressor mass flow rate, based on oxygen concentration in the exhaust's gas, has been developed and its reliability discussed. An automatic data acquisition system based on National Instruments hardware and Labview software has been set up. Once modified, the engine has been operated and characterized as first on diesel fuel, with the aim to settle a reference baseline for pollutant and CO₂ emissions, fuel consumption and power delivery. This study has been carried out within the framework of the first Russian Federation–European Union cooperative project “Bioliquids-CHP”, co-funded under the FP7 scheme from the European Commission (EC) for the EU-members and the Federal Agency for Science and Innovation (FASI) of the Russian Federation for the Russian partners.

Keywords

Biofuels, micro gas turbine, vegetable oil, biodiesel, bio-oil, pyrolysis oil.

Introduction

The Bioliquids-CHP cooperative project, funded under the FP7 scheme, aims to demonstrate to possibility to produce energy from bioliquids such as vegetable oil, biodiesel, pyrolysis oil and pyrolysis oil/diesel emulsions. Within the framework of the project, CREAR has to modify and adapt a Garrett micro gas turbine (MGT) model “GTP 30-67” to test alternative biofuels. The test campaign is divided into three phases: first, the engine was adapted with minor

Corresponding author: e-mail: david.chiaramonti@unifi.it, tel: +39-055-4796436, fax: +39-055-4796342

modifications for vegetable oil and biodiesel and characterized with diesel fuel, then (phase 2) a series of tests will be conducted with vegetable oil and biodiesel, and finally (phase 3) major modifications will be implemented to allow operation with pyrolysis oil and pyrolysis oil/biodiesel emulsions at 95/5%. The present work deals with the first phase of the work, and reports the minor modifications implemented on the MGT and measurement system that was installed on-board of the machine to acquire the relevant operating parameters. In particular, measurements of pressure, temperature, flowrate and gas concentration on air, exhaust and fuel streams were carried out, to determine a reference baseline of performance for comparison with alternative biofuel feeding.

With respect to diesel, VO physical properties (Table 1) show an increased density and viscosity, a lower LHV and depending on the specific seed from which it is extracted, a lower cetane number.

Table 1: chemical and physical properties of interest for Typical and high-oleic sunflower oil compared to #2 diesel fuel. VO characteristic as per DIN 51605 are also reported [1].

Properties	U.M.	DIN 51605	VO Sunflower	VO Sunflower	Diesel
		min - max	typical variety	high oleic	#2
Density 15°C	kg/m ³	900 -930	914	919	848
Flash Point	C°	220	274	240	60 - 80
LHV	kJ/kg	36000	37100	36500	42700
Kin. Visc.40°C	mm ² /s	36	37.1	33.6	2.7
Cetane number	-	39	37	48	40 - 55

Test bench layout

The Garrett micro gas turbine model “GTP 30-67”, showed in Figure 1, consists of a gear drive assembly, a centrifugal compressor and turbine rotating assembly, combustion chamber components (single silo combustor), enclosing plenum and housing, a lubrication system, a fuel system and an electrical system. The gear drive assembly consists of a reduction gear train with output and accessory drives of required RPM. There is an intake and an inlet screen before the centrifugal compressor. A single combustion tube is used in the combustion chamber. During operation of the engine at normal speed, the flyweight-type governor in the engine Fuel Control Unit (FCU) controls the fuel flow. An integral system of pneumatic and electromechanical controls provides automatic and coordinated control of engine start, acceleration, and operation. A minimum of additional controls, external to the engine, are required for initiating engines starts, starter and ignition cut-out, monitoring engine operation, and stopping the engine. The control system also consists of an over temperature thermostat mounted in the engine tailpipe [2]. The engine drives and alternator wich is rated for 25 kVA gross power output.

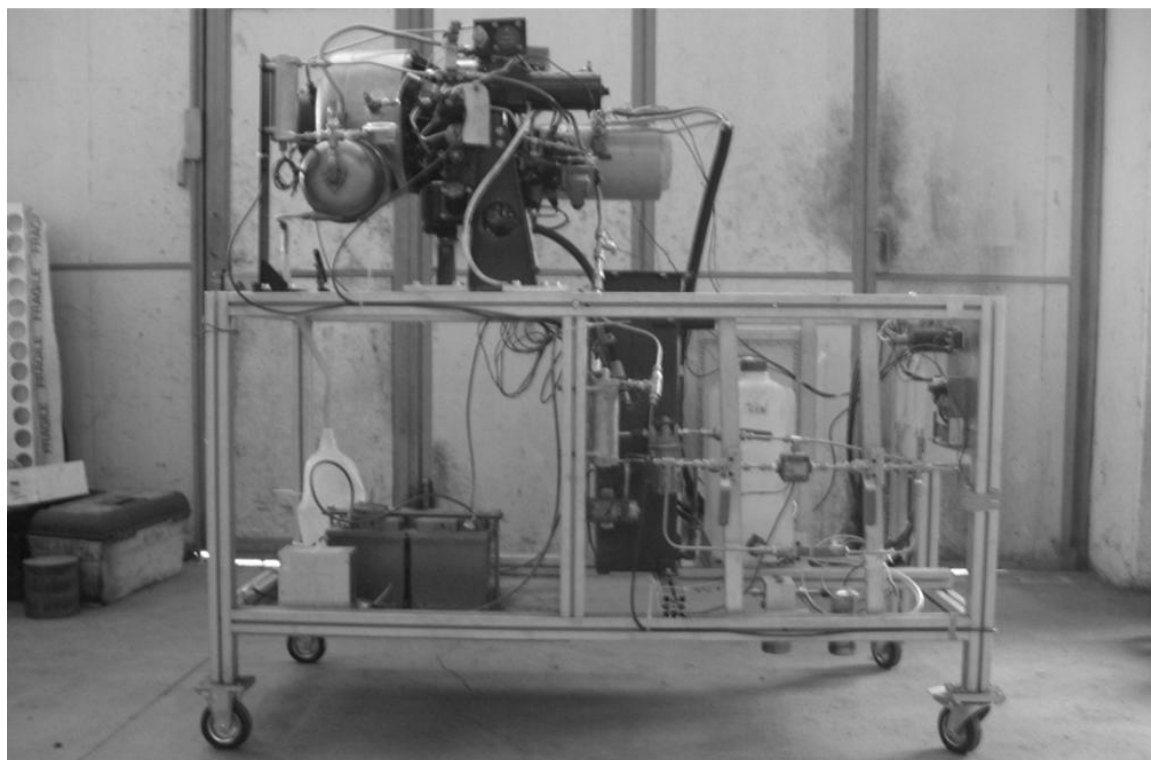

(a)

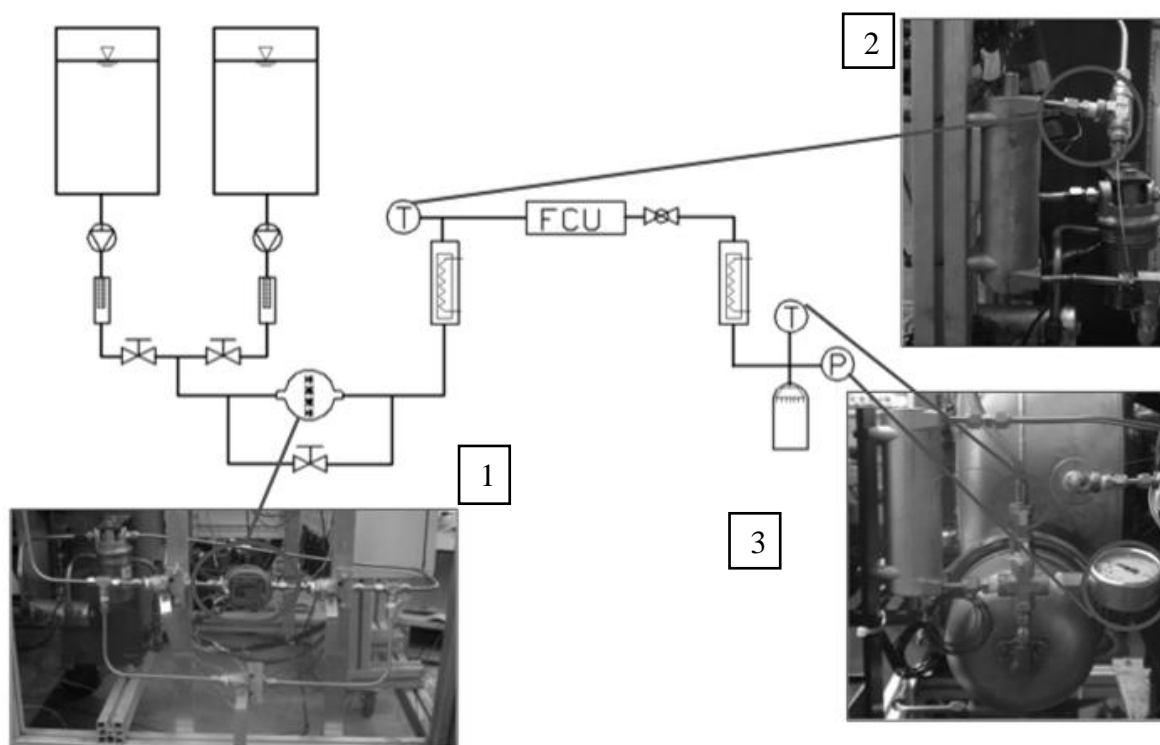

(b)

Figure 1: (a) MGT test bench. (b) Sketch of most relevant measurement point on the new fuel line of the MGT. Bottom left (1) is the fuel flow meter, top right (2) the first auxiliary heater and bottom right (3) the measurement points just before injector port.

Micro gas turbine test bench consists of a lightweight aluminium frame (hereafter referred to as *skid*) mounted on four rubber wheels; it is equipped with the engine on the upper plane, and fuels storages, batteries and controls on the lower one. Such a configuration gives an immediate access to all of the engine's parts for easy servicing. The test bench is showed in Figure 1a and

in the diagram of Figure 2. The MGT is on the top left corner. In this set-up, reported in Figure 1b, the engine is equipped with two separate fuel tanks, to accommodate diesel and the biofuel that is going to be tested. The fuel line is composed of three main sections, as per Table 2. The first section is comprised between the two storage tanks and the metering section; the second from the metering section to the FCU, and the third from the FCU to the injector. The fuel line features a two-steps pumping and heating-up of the fluid. This stepping is due to the FCU operating limits, which are: inlet temperature of max 50°C and inlet pressure of min 0.3 bar. Heating up of the fluid to the desired temperature is done by two Cast-X heat exchangers (Wattlow Inc., 500 W max for the first step, 1500 W max for the second). During operation, fluid is withdrawn from one of the two storage tank through a 40 µm cartridge filter from an alternative boost pump, battery powered. It passes through the metering section, consisting of a positive displacement oval-gear flow meter by Brooks® and a by-pass, then goes through a first auxiliary heater before entering the FCU. The FCU raises the fluid pressure to the value that is rated for injection and regulates the fluid flow rate to maintain a constant rotation speed basing on the requested load. Before entering the injector, fluid passes the admission valve, which is electrically actuated, and the second auxiliary heater, which raises the temperature of the fluid to improve atomization. Depending on the fluid viscosity, the temperature just before the injector can be as high as 40-50°C for both diesel and biodiesel, 90-100°C for vegetable oil. Switching from a fuel to another is done manually, operating on the respective admission valve that are installed just before

Table 2: fuel line temperature requirement

Section	From	To	Temperature
1	Storage tank	Metering section	ambient 20±30°C
2	Metering section	FCU	max 45°C
3	FCU	Injector	min 90°C max 120°C

An alternator (Bendix Corp., brushless, 8000 rpm CCW operating speed, 120/208 V, 3 phase, 400 Hz) is connected to the compressor wheel through a reduction gear train; the frequency of the delivered electrical power is proportional to the engine's rpm. For testing purpose, the MGT was equipped with a resistive load made of non-inductive resistors, which are intrinsically insensitive to frequency variations and with on-board control unit and replace its important function with an ad-hoc device, i.e. a separate exciter for the voltage regulation of the alternator. This device senses the frequency and amplitude of one of the three phases of the generator, and regulates accordingly the excitation current of the brushless generator. It is protected from under- and over-voltage, and features a low-speed protection, i.e. the excitation is inhibited until a minimum rpm is achieved. An in-house control panel was built, to allow manual start-up and shut-down of the engine as well as to control the auxiliary fuel pump for the biofuels under test. Energy supply to the generator set to power the starting motor is done thanks to a pack of two 12V/40 Ah leaded batteries connected in series and battery charging is done overnight.

Materials and methods

In order to determine the performance of the engine when operated on conventional and unconventional fuels, such as those of interest for the Bioliquids-CHP project, a number of measurements were carried out on the machine. These are measurements of pressure, fluid flow, gas species concentration, temperature, and rotational speed. Measurements on the micro gas turbine can be grouped in four families: air delivery, fuel line, exhaust and control, which

are performed on the engine, plus the electrical measurements on the load, i.e. voltage and current on each phase. Grouping and measurement points are reported in Table 3 as well as in Figure 2. Gas composition is a fundamental source of information for both combustion analysis and indirect measurement of air flow rate. For example, when considering the sole contribution of combustion process, thus discarding the influence of the fuel, the presence of unburned hydrocarbon UHC in the flue gas can be related to bad atomization, carbon monoxide (CO) to incomplete mixing or cold zones in the combustor, or vice versa NO to hot spots. Based on the assumptions above mentioned, measurement of oxygen concentration in exhaust can be used to infer the air flowrate, in a similar way to that adopted in the EPA method 19 [3]. The use of indirect measurement techniques, such as flow velocity at various radii, is a rather common practice [4] to determine air flowrate, and when supported by an analysis of error propagation, it offers rather reliable prevision.

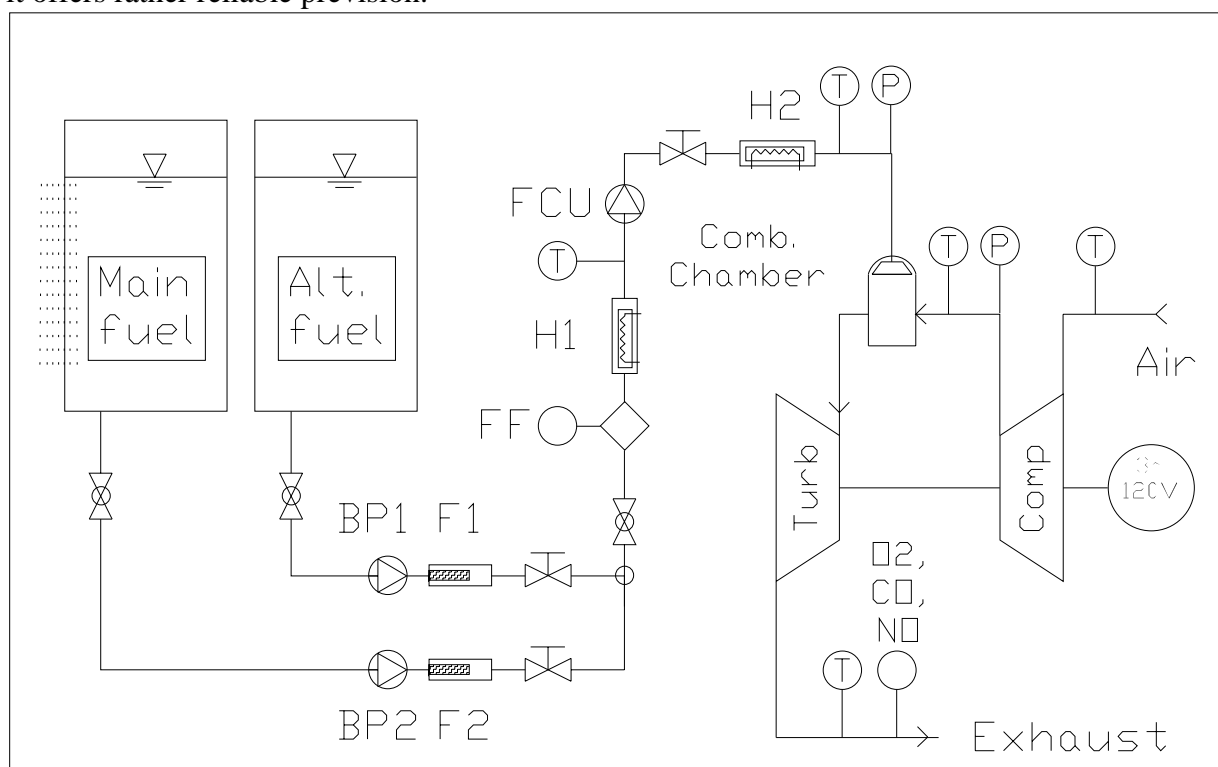

Figure 2: Schematic of the MGT test bench with indicated the location of relevant measurement points. “Main fuel” is the main fuel tank (i.e. diesel), “Alt. fuel” is the tank of either biodiesel or VO, “BP1-2” are boost pumps, “F1-2” are 40 μm filters, “FF” is the fuel flowmeter, “H1-2” are the heaters, “P” and “T” are pressure and temperature acquisition, “O₂, CO, NO” is the gas composition analyser. “Comb. Chamber”, “Turb” and “Comp” are combustion chamber, turbine and compressor sections.

Table 3: summary of the measurement points on the generator set

Section ID	Location	Description	Measurement	n.
Air delivery line	Engine	Pressure port of the FCU connected to the discharging volute of the compressor	Pressure	1
			Temperature	1
Fuel line	Engine	Feeding line from the fuel storage to the combustion chamber	Temperature	2
			Pressure	1
			Mass flow	1
Exhaust	Engine	Gas flow at the turbine	Temperature	1

		outlet	Concentration (O ₂ , CO, NO)	1
Control		Turbine's rpm	Frequency	1
Load	Resistive load	Electrical parameters of the load	Voltage	3
			Frequency	1
			Current	3

In the present study, air/gas flow rate is used to deduce mean flow velocities in the sections of interest, i.e. combustor annulus and turbine outlet. On the side of temperature measurement, the exhaust temperature is acquired to make estimation on turbine stage efficiency. A bench of anti-inductive ceramic resistors composes the three-phases resistive load section. This part of the system converts to heat the electric energy produced by the alternator; in this section, each phase is monitored, to have an exact as possible figure of the power production. Current, frequency and voltage measurements are carried out with a single multimeter designed to work at 400 Hz.

Pressure measurement

Static pressure measurements are done with series M5100 from Measurement Specialities; the pressure port is machined from a solid piece of 316L stainless steel, and process connection size is ¼" NPT. There are no O-rings, organics or welds exposed to the pressure media. Sensors are rated for a long-term stability of ±0.25% of full scale, a total error band of ±1%, an accuracy of ±0.25% full scale BFSL, and an operating temperature range of -40° to 125°C. The output range is 0-10 V.

Temperature

Temperature measurements are done with T and K type thermocouples, with an outer diameter of the wire of 0.25 mm and 3 mm respectively. T type thermocouples are used to measure ambient (one), compressor delivery (one) and fuel temperature (two), whereas K type is for turbine outlet (one). All thermocouples are stainless steel sheathed.

Fuel flow rate

Fuel flow rate is measured by a positive displacement Brooks® BM01 oval flowmeter. Because the amount of slippage between the rotors and the measurement chamber wall is minimal, the flowmeter is essentially unaffected by changes in viscosity and lubricity of the liquid. Meter's body, rotors, rotor's shaft and bearings are in 316L (stainless steel), O-ring is in Viton® (a spare O ring in Teflon® has been acquired for testing purpose). The meter is calibrated and accounted for a precision of less than 1% of the reading.

Gas concentration

Analysis of gas concentration is done with an on-line, hand operated gas analyser capable of measuring CO, O₂, and NO concentrations. The insertion point is located on the turbine discharge cone, two centimetres after the access for the temperature measurement. In addition to the environmental implications, exhaust gas composition play an important role in the indirect measurement of airflow. Within the Bioliquids-CHP project, the combustion chamber of the Garrett MGT will be object of a numerical and CFD investigation to highlight which part of the combustor could be eligible of major modification to allow a safe operation of the engine with unconventional biofuels such as pyrolysis oil. With this aim, a simple method to estimate the mass flow rate operated by the compressor by means of the oxygen concentration has been developed. Assuming that:

- For a gas turbine, the actual air of combustion per kg of fuel is higher than stoichiometric ($\alpha_{REAL} > 30$);

- For a specified fuel, the stoichiometric air of combustion (α_{ST}) is known and equal to 14 kg of air per kg of diesel;
- Fuel flowrate is known from direct measurement;
- The combustion is complete.

It is possible to show that the air excess, i.e. the dilution flowrate that is necessary to reduce the maximum temperature inside the combustor, determines the air content in the exhaust, and therefore the air flowrate can be related with a rather simple algebraic equation to the oxygen concentration at the turbine outlet. The following equation summarizes this consideration:

$$\dot{m}_a = \dot{m}_{st} + \frac{\chi_{O_{out}} \cdot \dot{m}_c \cdot (1 + \alpha_{st})}{\chi_{O_{aria}} - \chi_{O_{out}}}$$

Where:

- \dot{m}_a is the air flowrate through the compressor;
- \dot{m}_{st} is the stoichiometric flowrate of air, i.e. α_{ST} times the fuel flowrate \dot{m}_c ;
- $\chi_{O_{aria}}$ and $\chi_{O_{out}}$ are the oxygen concentrations in air and exhaust respectively [mass based].

Data acquisition modules

Data acquisition is performed through three National Instrument USB modules, supported by the NI c-DAQ-9178 chassis. It is designed for small, portable, mixed-measurement test systems. The cDAQ-9178 can be combined with up to eight NI C Series I/O modules for a custom analog input, analog output, digital I/O, and counter/timer measurement system. The installed modules are NI 9401 for digital input/output, NI 9207 for voltage and current measurements, NI 9213 for thermocouple acquisition.

Results

The MGT was initially characterized at diesel fuel, and its most relevant data acquired to settle a baseline for performance comparison with alternative biofuels. Measurements involved the following parameters:

- Fuel injection pressure [bar], temperature [°C] (on the same point) and flowrate [l/h];
- Compressor delivery pressure [bar] and temperature [°C];
- Turbine discharge temperature [°C];
- Exhaust gas dry composition in terms of CO₂, O₂, NO, NO_x and CO [% vol].

Ambient conditions for the test were ambient temperature between 35 and 38°C, and relative humidity of 60%. Values have been acquired with the engine in steady state for 6 load conditions, namely from idle to full load, i.e. 25 kW, in steps of 5 kW.

Compressor air delivery

At the delivery section the measurements showed a static temperature ranging from 142.6±0.6°C in idle state, to 161.8±0.6°C at full load and a static pressure of 1.3±0.1 bar (gauge). Due to the direct connection to the gear train, the engine rotates at a constant speed and thus the air mass that is compressed is independent from the load level. The compressor ratio (β) is equal to 2.3 at every condition.

Fuel line

The MGT regulates the power output varying the fuel flow rate delivered to the combustion chamber and thus the air to fuel ratio because it is a fixed-rpm engine. The measurement carried out on the fuel line shows that the fuel consumption varies between 18.3±0.2 l/h at idle

to and 34.6 ± 0.4 l/h. Diesel injection pressure increases as fuel flowrate does, its variation being between 7.0 ± 0.1 bar gauge at idle and 8.9 ± 0.1 bar gauge at full load.

Exhaust

Measurements of gas composition (by volume on dry basis) and temperature were carried out at the turbine discharge cone. With regard to the gas analysis, Oxygen along with NO and CO at 15% O₂ concentrations are reported in Figure 3. Oxygen concentration is measured with $\pm 0.1\%$ vol accuracy, CO with $\pm 4\%$ of the reading over 300 ppm and ± 10 ppm below 300 ppm, NO with ± 5 ppm.

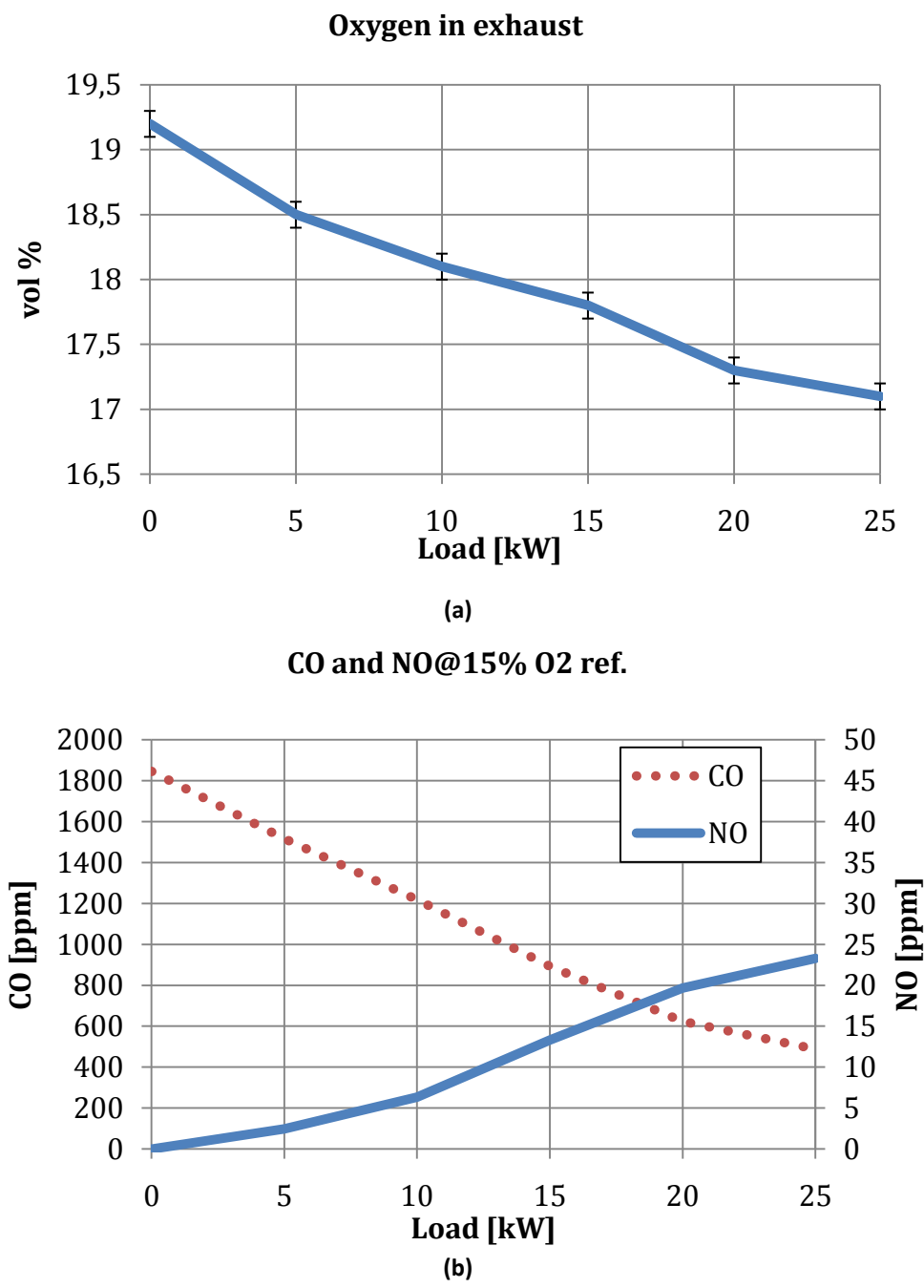

Figure 3: (a) O₂ concentration at the exhaust [% by volume on a dry base]. (b) NO and CO at 15% reference Oxygen concentrations [ppm] as function of the load [kW].

NO and CO concentrations are referenced to 15% oxygen in the exhaust as per the following equation:

where:

- is the reference oxygen concentration (15%);
- is the actual oxygen concentration;
- is the species actual concentration;
- is the species corrected concentration;

We can observe that at increasing load, NO and CO trends rises and falls respectively, since the engine moves toward operating points with decreased air to fuel ratios.

With regard to exhaust temperature, measurements shows that it ranges between 319.3 ± 1.3 °C at idle state to 581.8 ± 2.3 °C at full load.

Mass flowrate elaborated by the compressor

Basing on the assumptions detailed in the paragraph “Gas concentration”, calculation shows that air mass can be estimated between 2131 and 2755 kg/h, and the standard deviation among calculated values at every operating point is in the order of 9.6%. Calculate values for each load are reported in Table 4.

Table 4: air mass flowrate [kg/h] calculation at increasing load [kW]

Load [kW]	0	5	10	15	20	25	Avg.	Standard deviation %
air flowrate [kg/h]	2755	2188	2131	2150	2146	2279	2275	9,6%

Conclusion

Within the framework of the Bioliquids-CHP project, a Garrett GTP 30-67 micro gas turbine fed with diesel fuel has been acquired and modified to allow a safe feeding of the engine with alternative biofuels such as vegetable oil and biodiesel. A preliminary characterization of the MGT on diesel fuel from idle state (no load) to full load (25 kW) has been completed, to determine a reference baseline for future comparison with alternative biofuels. The system is now ready for testing with vegetable oil and biodiesel that will be matter of a future publication.

Nomenclature

Symbols	Acronyms
T Temperature [K]	ADC Analog-to-digital converter
p Pressure [bar, barg]	TC Thermocouple
χ Gas concentration [%vol]	CCW Counter clock-wise
P Power [kW]	LHV Lower heating value
V Voltage [V]	FCU Fuel control unit
Hz Frequency [Hz]	BD Biodiesel
g gauge	VO Vegetable oil
Subscripts	BSFL Best fit
v, vol Volume, by volume (e.g. gas concentration)	CHP Combined Heat and Power
m Mass, by mass	RPM Revolution Per Minute
rms Root mean square	

References

- [1] Prussi M., “Development of a multi-fuel micro gas turbine for pure vegetable oil”, Università degli Studi di Firenze Doctoral Thesis, 2010
- [2] Garrett/Honeywell, 1974, “Technical Manual – Field maintenance instructions”
- [3] EPA method 19 - SO₂ Removal & PM, SO₂, NO_x Rates from Electric Utility Steam Generators, <http://www.epa.gov/ttn/emc/methods/method19.html>
- [4] British Standards Institution, “Methods of measurement of fluid flow in closed conduits” Part 1 Section 1.1, London: BSI, 1981, Series: BS 1042: Part 1, Section 1.1, 1981 - 5 -

Acknowledgements

This study has been carried out within the framework of the first Russian Federation–European Union cooperative project “Bioliquids-CHP”. The BioLiquids-CHP project is financially supported by the European Commission (Seventh Framework Programme; Grant FP7-227303) and the Federal Agency for Science and Innovation at the Ministry of Education and Science of the Russian Federation (FASI contract 02.527.11.0003).

