

Eur. Phys. J. Special Topics **141**, 133–136 (2007)
© EDP Sciences, Springer-Verlag 2007
DOI: 10.1140/epjst/e2007-00030-2

THE EUROPEAN
PHYSICAL JOURNAL
SPECIAL TOPICS

Acoustic phenomena in filled porous glasses by time-resolved spectroscopy

R. Cucini¹, A. Taschin^{1,2}, C. Ziparo^{1,2}, P. Bartolini^{1,2} and R. Torre^{1,2,3}

¹ European Lab. for Non-Linear Spectroscopy (LENS), Univ. di Firenze, via N. Carrara 1, 50019 Sesto Fiorentino, Firenze, Italy

² INFN-CRS-Soft Matter (CNR), c/o Univ. la Sapienza, Piazz. A. Moro 2, 00185 Roma, Italy

³ Dip. di Fisica, Univ. di Firenze, via Sansone 1, 50019 Sesto Fiorentino, Firenze, Italy

Abstract. We studied the propagation of ultrasonic acoustic waves in two porous glasses characterized by different pore diameters (4 and 200 nm) filled with carbon tetrachloride. Using a time-resolved optical spectroscopic technique (Transient Grating) we can measure the acoustic dynamics of these systems. The sound velocities, measured in both the samples, show high values compared with the sound velocity of bulk carbon tetrachloride; they cannot be predicted by the simple effective medium model, but are in good agreement with the estimate obtained from the Biot theory.

1 Introduction

The study of nano-confined liquids (i.e. liquid geometrically confined on length scales of few nanometers) is a novel and relevant topic of condensed matter physics.

The attention of this investigations pertain to the technological applications and to the fundamental physics. In the first case, confined liquids play an important role in lubrication, microfluidics, heterogeneous catalysis, in the study of water trapped in proteins and oil trapped in porous rock. In the second case, it's interesting to study and understand the general proprieties of materials characterized by nano-heterogeneity.

Nano-porous silica glasses have proven to be excellent media for this research. In a porous glasses is present a random network of empty pores that defines a solid matrix. When we fill it with a liquid such matrix acts as a solid confinement in cylindrical pores with diameters of few nano-meters. In particular, we have used two type of these glasses: Vycor 7930, with average pore size of 4 nm and 28% of porosity and a second porous matrix with a pore size of 200 nm and 28% porosity. Both samples are produced by the Advanced Glass and Ceramics, USA.

We have filled these glasses with carbon tetrachloride (CCl_4). We use CCl_4 for the following features: 1) The refractive index of this liquid matches the refractive index of the fused silica. This is an essential property to perform an optical experiment in the visible range in the sample with pore size of 200 nm. 2) CCl_4 is a spherical simple molecule which can not make strong bounds with the inner pore surfaces.

We investigated the transport phenomena, in particular the acoustic processes, in the system porous glasses- CCl_4 by a heterodyne detected transient grating experiment (HD-TG). During the last years these experiments have been used extensively and successfully for probing the dynamics of supercooled liquids [1–6]. This time-resolved spectroscopic tool is able to probe a very broad time window, typically from 10^{-9} to 10^{-3} s, covering with a single experiment a dynamic range hardly explored by other methods. With this technique is possible to gain relevant information on the acoustic propagation.

We compare our results with the effective medium model and Biot theory [7,8], that represent the fundamental theoretical models to describe the acoustic propagation in nano-structured system.

2 Experiment and sample

2.1 Porous glasses

Both the samples (4 and 200 nm porous glass) is supplied in cylindrical form, with a diameter of 8 mm and 4 mm thickness, by Advanced Glass and Ceramics. These materials are produced by sol-gel technique. A glass forming melt is composed by SiO_2 and B_2O_3 . It is forced to spinodally decompose into a SiO_2 -rich phase and a B_2O_3 -alkali oxide-rich phase. This latter phase is leached out by appropriate solvents, leaving a fully penetrable porous glass, with a porosity of 28%.

The procedure for cleaning the porous sample must be performed with great attention because they absorb easily any organic substances. The samples are first accurately cleaned through a full immersion in a solution of hydrogen-peroxide and then washed with water. Then, in order to remove residues of water from the glasses, we have heated the systems at $800^\circ C$, and maintained this temperature for several hours. After this procedure, the samples are kept into pure CCl_4 until used. Similar attention must be posed for the matrix with a pore size of 200 nm.

2.2 The transient grating experiments

The TG experiment is a non-linear spectroscopic technique that can be classified between the general framework of the four-wave-mixing spectroscopy [9,10]. The experimental details concerning the laser and the optical set-up are extensively reported in [3], here we recall only the main features in order to make clear the present TG data and results. The lasers and the optical set-up used to realize the HD-TG experiment are reported in fig. 1 and fig. 2. The excitation is produced by two infrared pulses at 1064 nm wavelength, 100 ps duration, $35 \mu J$ energy, and with a repetition rate of 100 Hz. The pulses are generated by an amplified laser system: a mode-locked Nd-YAG laser (Antares-Coherent) followed by a regenerative Nd-YAG cavity (R3800-Spectra Physics). The two pulses are incident on the sample and their interference produces a temperature/density spatial grating inside the sample.

The probing beam, at 532 nm wavelength with 6 mW averaged power after chopping, is produced by a diode-pumped intracavity-doubled Nd-YVO (Verdi-Coherent); this is a CW single-mode laser characterized by an excellent intensity stability with low and flat noise-intensity spectrum. We uses a phase grating as a diffractive optical element (DOE) made by Edinburgh Microoptics to diffract both laser fields. The excitation grating induced in the sample is the mirror image of the enlightened DOE phase pattern and it is extended in the q direction (≈ 5 mm); viceversa the probing beam is focalized in a circular spot (≈ 0.5 mm in

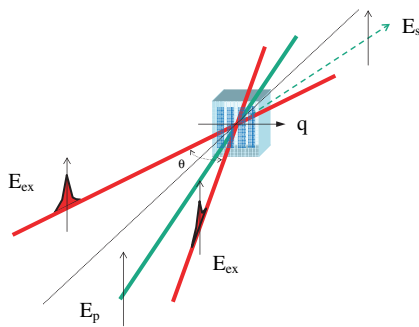

Fig. 1. Sketch of the polarization configuration and beam directions. E_{ex} are the excitation laser pulses and the E_p and E_s are the probing and diffracted beams, respectively. For each beam we used vertical polarizations, as reported.

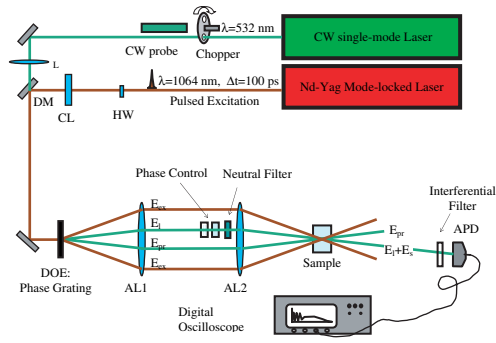

Fig. 2. Optical set-up and laser system for HD-TG experiment: HW#: half wave plate; CL#: cylindrical lens; DM: dichroic mirror; DOE: diffractive optic element; AL#: achromatic lens; APD: amplified photodiode.

diameter). The use of a DOE improves substantially the TG experiments [3, 11, 12]. The HD-TG signal, after optical filtering, is measured by a DC-12 GHz amplified photodiode (NEW FOCUS 1580-B) and recorded by the optical input of a Tektronix oscilloscope with a bandwidth of 7 GHz and a sampling rate of 20 Gs/s.

3 Results and discussion

We performed HD-TG measurements on the porous glass- CCl_4 systems in the temperature range 260–345 K. Figure 3 shows a typical HD-TG signal, with a temperature of 295 K and $q = 1.395 \mu\text{m}^{-1}$, corresponding in these samples to a frequency of $\nu \simeq 800$ MHz. Each data is an average of 5000 recording, and this is enough to produce an excellent signal-to-noise ratio, thanks also to the heterodyne detection, that increases substantially the quality of data.

The sound velocity may be obtained directly from HD-TG data, but a complete analysis of the physical quantities requires a fitting procedure. The fitting function that we have used is:

$$S(q, t) = A \exp(-t/\tau_s) \sin(c_s q t) \quad (3.1)$$

where c_s is the sound velocity, τ_s the acoustic damping, A the oscillation amplitude. The fitting includes a convolution with the instrumental response (amplified photodiode and oscilloscope); this procedure is particularly important at short time of the signal. To evaluate the errors on fit data, we used an “*a posteriori*” procedure. We repeat the experiment, then we fit all the signals producing a distribution of parameters.

In figure 4 we report the sound velocity, obtain by our data, versus temperature, for 4 nm and 200 nm porous matrixes. The acoustic velocity data do not show any temperature dependence but they show clear different value for the two samples. This difference suggest a dependence by the pore diameters. Nevertheless this statement relay on the stability of sample parameters (porosity and composition), given by the producing company and not directly measured by us. The first estimate of the sound velocity in an heterogeneous media can be found using

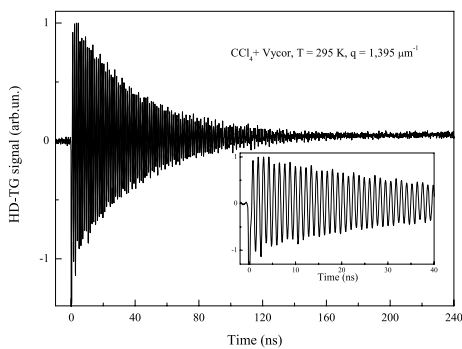

Fig. 3. Typical HD-TG data corresponding to $T = 295$ K and $q = 1.395 \mu\text{m}$.

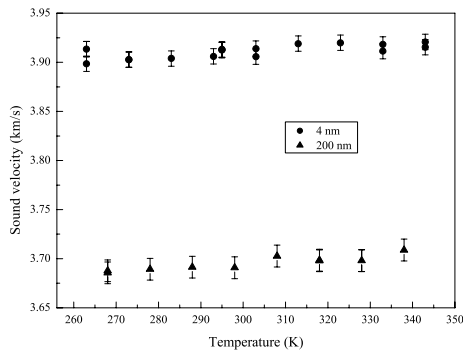

Fig. 4. Comparison between the experimental sound velocity versus temperature in Vycor (pore size = 4 nm) and in the second porous matrix (pore size = 200 nm) at $q = 1.395 \mu\text{m}$.

the effective medium model. In the present samples this model will predict a velocity not dependent by the pore diameters with a value of $v \simeq 1600 \text{ m/sec}$ (given $v_{\text{silica}} \simeq 6000 \text{ m/sec}$ and $v_{\text{CCl}_4} \simeq 900 \text{ m/sec}$). So evidently, this model is too simple and not appropriate to describe our data. The Biot theory has been recognized as a valid model for filled porous glasses [7, 8]. Indeed also this model does not predict a dependence of the acoustic velocity by the pore diameters in the main sound wave, but the evaluation of the velocity gives $v \simeq 3800 \text{ m/sec}$ in substantial agreement with our results.

4 Conclusions

We have studied the propagation of the high frequency acoustic waves in two filled porous glasses characterized by very different pore size. The transient grating experiment revealed to be particularly appropriate to these investigation producing data of excellent quality. In both the samples, the experimental results found an high value for the ultrasound velocities, compared with the value of the liquid-bulk. These data are characterized by a weak dependence from the pore diameters and are in fair agreement with the Biot theory prediction. In order to safely claim a pore dependence we need to directly investigate the sample basic parameters. Indeed the measured difference in the velocities could be ascribed to a not constant value of the porosity between the 4 and 200 nm porous glasses, as viceversa claimed by the company.

References

1. Y. Yan, K.A. Nelson, *Phys. Rev. Lett.* **74**, 4883 (1995)
2. Y. Yan, K.A. Nelson, *J. Chem. Phys.* **103**, 7722 (1995); *ibid.* *J. Chem. Phys.* **103**, 7732 (1995)
3. R. Torre, A. Taschin, M. Sampoli, *Phys. Rev. E* **64**, 061504 (2001)
4. A. Taschin, R. Torre, M. Ricci, M. Sampoli, C. Dreyfus, R.M. Pick, *Europhys. Lett.* **56**, 407–413 (2001)
5. A. Taschin, P. Bartolini, M. Ricci, R. Torre, *Phil. Mag.* **84**, 1471–1479 (2004)
6. A. Taschin, R. Eramo, R. Torre, *Transient Grating Experiment on Complex Liquids* (Springer, New York, 2006) (in press)
7. M.A. Biot, *J. Acoust. Soc. Am.* **28**, 168–178 (1956)
8. M.A. Biot, *J. Acoust. Soc. Am.* **28**, 179–191 (1956)
9. Y.R. Shen, *The Principles of Nonlinear Optics* (Wiley-Interscience, New York, 1984)
10. H.J. Eichler, P. Gunter, D.W. Pohl, *Laser-Induced Dynamic Gratings* (Springer-Verlag, Berlin, 1986)
11. G. Goodno, G. Dadusc, R.J. Dwayne Miller, *J. Opt. Soc. Am. B* **15**, 1791 (1998)
12. A.A. Maznev, K.A. Nelson, J.A. Rogers, *Opt. Lett.* **23**, 1319 (1998)