



UNIVERSITÀ
DEGLI STUDI
FIRENZE

FLORE

Repository istituzionale dell'Università degli Studi di Firenze

Seat assist device for elderly and disabled people

Questa è la Versione finale referata (Post print/Accepted manuscript) della seguente pubblicazione:

Original Citation:

Seat assist device for elderly and disabled people / G. CASCINI; G. MONTELATICI; P. RISSONE; F. ROTINI. - (2007).

Availability:

This version is available at: 2158/244456 since:

Terms of use:

Open Access

La pubblicazione è resa disponibile sotto le norme e i termini della licenza di deposito, secondo quanto stabilito dalla Policy per l'accesso aperto dell'Università degli Studi di Firenze (<https://www.sba.unifi.it/upload/policy-oa-2016-1.pdf>)

Publisher copyright claim:

(Article begins on next page)



(11) **EP 1 913 918 B1**

(12) **EUROPEAN PATENT SPECIFICATION**

(45) Date of publication and mention
of the grant of the patent:
16.02.2011 Bulletin 2011/07

(51) Int Cl.:
A61G 5/14 (2006.01)

(21) Application number: **07118748.8**

(22) Date of filing: **18.10.2007**

(54) **Seat assist device for elderly and disabled people**

Sitzhilfevorrichtung für ältere und behinderte Personen

Dispositif d'assistance pour s'asseoir pour personnes âgées et handicapées

(84) Designated Contracting States:
**AT BE BG CH CY CZ DE DK EE ES FI FR GB GR
HU IE IS IT LI LT LU LV MC MT NL PL PT RO SE
SI SK TR**

(30) Priority: **18.10.2006 IT FI20060253**

(43) Date of publication of application:
23.04.2008 Bulletin 2008/17

(73) Proprietor: **Universita' Degli Studi di Firenze**
50121 Firenze (IT)

(72) Inventors:
• **Cascini, Gaetano**
50124, Firenze (IT)

- **Rissone, Paolo**
51016, Montecatini Terme (Pistoia) (IT)
- **Rotini, Federico**
51039, Quarrata (Pistoia) (IT)
- **Montelatici, Gianni**
50129, Firenze (IT)

(74) Representative: **Bardini, Marco Luigi et al**
Società Italiana Brevetti SpA
Corso dei Tintori, 25
50122 Firenze (IT)

(56) References cited:
DE-A1- 4 408 458 DE-U1- 29 808 584
GB-A- 2 191 683 US-A- 5 918 936
US-A- 6 113 188 US-B1- 6 547 330

EP 1 913 918 B1

Note: Within nine months of the publication of the mention of the grant of the European patent in the European Patent Bulletin, any person may give notice to the European Patent Office of opposition to that patent, in accordance with the Implementing Regulations. Notice of opposition shall not be deemed to have been filed until the opposition fee has been paid. (Art. 99(1) European Patent Convention).

Description

[0001] The present invention relates to the field of domestic mobility aiding devices destined for persons with reduced mobility, such as those with physical disabilities caused by sickness, injury or simply by the age. More particularly, the invention relates to a new device destined for seat assistance, i.e. for aiding the person to stand starting from a seated position.

[0002] The motion involved in lifting the barycentre of a seated person when attempting to stand erect is comprised of two main components: a translation in a forward direction associated to a translation in an upward direction. In this way, the position of the human body is constantly maintained in such a manner that it is able to ensure uniform and well-balanced weight distribution on the bone and muscle structure of the lower limbs.

[0003] The aforesaid motion involves the participation of a large portion of the bone and muscle structure, in both the lower limbs as well as the medium to lower part of the trunk. After an injury or because of degenerative phenomena due to some pathology or simply because of physiological reasons such as the aging process, it can happen that the person loses considerable mobility functions to the point that even a normally simple movement such as getting up from a chair or an armchair becomes impossible or at the least, extremely difficult.

[0004] For this reason, prior art provides for armchairs, chairs or seats (including some for use on WC toilet seats or other bathroom facilities) which use motorized mechanisms of various kinds that are able to rise up in a controlled manner, inclining and elevating the seating plane, in such a manner that the lumbar region and back of the person is lifted and pushed forward to permit the change from a seated to an erect position with far less effort. Obviously, the reverse movement permits to support and assist the return to a seated position, making the motion more gradual and reducing the possibility of injury.

[0005] However, the solution described above presents a drawback in that it requires a dedicated structure, this meaning that the user is forced to purchase a specific piece of furniture (generally quite expensive) or at least a frame which is rather difficult to move from one particular position. Moreover, the user is forced to use always and exclusively that same piece or frame if he wants to take advantage of the rising aid functionality. Additionally, the size and weight of the structure to be moved also imposes the use of motorised lifting mechanisms that are complex and costly in relation to both production as well as maintenance.

[0006] Taking these aspects into consideration, more economical aiding devices have been proposed in the form of plain cushions that are placed on the seat of a conventional existing armchair or chair. This means that the user is not forced to buy a new armchair or chair (with all the consequent problems of cost, bulk and appearance), and at the same time the system provides a lifting aid adaptable on all existing types of chair, simply by

moving the device from one chair to another.

[0007] Devices of this type are shown in the European patent application EP1310227 and the United States patent US5316370. Both these devices have a structure with a base which is positioned on the seat of the chair or armchair, and a shell that is articulated in relation to the base. The convex surface of the shell acts as a new (mobile) seat. The articulation of the shell in relation to the base is driven and controlled by a motorized mechanism positioned between the two elements. When in closed position, i.e. when the seating surface is in a substantially horizontal position, the mechanism is housed inside the cavity defined by the convex surface of the shell.

[0008] In these devices, the seating surface simply rotates around an axis that extends along the front side of the seat, in other words, the side adjacent to the knees of the sitting user. This is not totally satisfactory in relation to the need of assisting the natural rising motion in the best possible manner, because, as described above, this motion is composed of a combined forward translation movement with an upward translation of the body. In practice, the user is lifted by means of a simple rotation of his barycentre; further to said rotation, the barycentre becomes displaced backwards with respect to the vertical line conducted from the user's feet. This involves an additional muscular effort which is considerable, and which can also lead to dangerous loss of balance. A further seat assist device according to the preamble of annexed claim 1 is disclosed in DE4408458.

[0009] The object of the present invention is to provide a cushion similar to that described above, but wherein the motion of the seating surface is more similar to that naturally performed by the human body when rising to an erect position, therefore assisting the user in a more efficient manner, requiring less effort and minimizing the risk of loss of balance during the lifting action.

[0010] A further object of the present invention is to provide a cushion of the aforementioned type, wherein the motion of the seat surface is driven by a mechanism having a basic structure and simple operation.

[0011] These objects are achieved with the seat assist device according to the present invention, whose essential characteristics are defined by the first of the appended claims.

[0012] The features and advantages of the seat assist device according to the present invention will be made apparent from the following description of embodiments thereof provided as a non-limiting example, with reference to the appended drawings wherein:

- figures 1 and 2 show schematic side views, with parts omitted, of the device according to the invention in a first embodiment, shown respectively in a closed or sitting configuration, and in an open or lifting configuration;
- figure 3 shows a dimensional variant of the device shown in the previous figures in an open configuration as in figure 2;

- figure 4 shows a perspective view of the device in a second embodiment of the invention, in a partially open configuration; and
- figure 5 shows a perspective view seen from a different angle of the device shown in figure 4 in a constructive variant.

[0013] With reference to figures 1 and 2, a device according to the present invention comprises a base 1 composed, in this example, of a plate-shaped body defining a resting surface 1 on the underside for being positioned in a horizontal position on the surface of the seat of a conventional chair or armchair (not illustrated).

[0014] Furthermore, the device comprises a mobile seat 2, in this example, having a disk-like shape of a size that substantially corresponds to that of the base 1, and defining on the upper side a substantially plane seat surface 2a.

[0015] The seat 2 is connected to the base 1 so as to be movable between a closed configuration (figure 1), wherein the two bodies are adjacent to one another, and an open configuration (figure 2), wherein the seat 2 is displaced both in an orthogonal direction in relation to the base 1, and in a parallel direction with respect to said base towards the front side. This latter side is the one resulting in front, from the point of view of a user sitting on the seat 2, identified at the numeral 1a on the base 1 and at the numeral 2b on the same seat. Moreover, in the open configuration, the seat 2 is set at an angle in relation to the horizontal plane, sloping towards the front side 2b. The two configurations just described clearly correspond, respectively, to that for receiving the user in a sitting position, and to the lifted one required by the user for assuming an erect standing position without effort.

[0016] The connection between the base 1 and the seat 2, so that the latter is mobile in relation to the former between the closed and open configuration and vice versa, is ensured by a mechanism 3 comprising a couple of articulations 4 arranged among the lateral sides, indicated respectively at the numerals 1b and 2c for base 1 and seat 2, positioned on each flank of the user when sitting. Each articulation 4 comprises two crossed arms 5, 6, mutually hinged in the point of contact by a pivot 7, set in a substantially central position in relation to the lengthwise direction of the arms. A first arm 5 is pivotally connected at respective ends to base 1, in proximity to the front side 1a, and to the seat 2, in proximity to the rear side identified by numeral 2d, by means of pivots 8, 9. A second arm 6 is arranged in the opposite way, extending between the rear part of base 1 and the front side of seat 2. However, in this case the connection of the end of the arm with the base and the seat is carried out by means of roto-translation couplings comprising sliders 10, 11 projecting from arm 6 and slidingly engaged in respective guides 12, 13 set respectively along the lateral sides of base 1 and seat 2.

[0017] Drive means, arranged between the two bodies and acting directly on the bodies or on mechanism 3, are

provided to control the motion between the two configurations. Said means, not illustrated but *per se* known or obvious, can comprise a mechanical or pneumatic actuator, an air spring, an inflatable device or the like, as will be discussed further on. Analogously, the relative propulsion means have not been illustrated for the same reason, but these will comprise suitable electric motor means and relative batteries.

[0018] The geometry of the two articulations 4 and the kinematics of the relative connections is conceived to ensure a very compact closed configuration, with the seat 2 which approaches and is set on top of the base 1; in this configuration the sliders 10, 11 of the second arm move to the ends of their runs, respectively to the rear and front of the guides 12, 13. In the lifting configuration kept stable by the action of the drive means, while the base 1 is maintained in a fixed horizontal configuration, the seat 2 elevates and moves forward slightly sloping, to assist the lumbar region of the user in a movement that is truly similar to the natural rising movement.

[0019] By modifying the geometries of the two arms 5 and 6, it is also possible to adapt the degree of the slope and the translation in the most suitable manner according to the user's requirements. As shown in the dimensional variant in figure 3, wherein components identical to those previously described are identified by the same reference numerals, a second arm 6 in which the segment between the pin 7 and the slider of the upper end 11 is longer than the example described previously, will provide a slope for the seat 2 on a slightly lesser angle. Similar dimensional adjustments are able to regulate the extent of the two translation movements. Said adjustments can also be obtained by using arms 6, 7 having a telescopic structure, or in any case arms that can be adjusted in length, in a discrete manner for pre-established lengths as well as continuously (such as with snap engagement systems or a threaded rod with a nut and counter nut).

[0020] A similar kinematic system to that previously described can be realised with different embodiments of mechanism 3. With reference to figure 4, wherein corresponding reference numerals show components that are identical or equivalent to those previously described for the former embodiment, in each articulation 104, rather than being purely rotational, the connection between the upper end of the first arm 105 and the seat 2, is of a roto-translation type, thanks to a simple sliding contact of said end on a guide strip 109. A tie rod 115 extends between the first arm 105 and the seat, with an arrangement that is substantially parallel to the second arm, being engaged at both ends by the respective pivots 116, 117.

[0021] The tie rod 115 links the translation of the seat 2 with the rotation of the first arm 105, preventing a free horizontal sliding on the guides 109, 113. A further variant can provide for the replacement of the tie rod 115 with a guide cam which, on seat 102, acts as a guiding element for a slider attached to the second arm 106. In this case as well, by adjusting the length of the linear elements (arms and tie rods) it is possible to adapt various func-

tional parameters according to personal requirements: lifting height, forward displacement of the seat, and rotation angle of the same.

[0022] The embodiment shown in figure 4 shows that the guides 112 along the lateral sides 101b of the base 101 are specifically outlined, in particular, with a segment 112a that rises on a slope in an upward direction. This specific shape, or other similar forms, can be used in turn to control the various movements of the seat 2 in different ways. This figure also shows with more precision, and purely as an example, certain constructive solutions that could be adopted as alternatives.

[0023] In particular, the guides 112 are each realised on a double ridge 101c rising along one lateral side 101b of a basic flat rectangular element that forms the main body of the base 101. In turn, the second arms 106 have a structure with two parallel rods 106a, inside which the first arms 105 and, in this case, also the tie rods 115, are inserted at the crossing points. Again, the seat 102 comprises a sliding seat surface 102a, which can travel back and forward, with a certain degree of resistance, in relation to the underlying structure on which the drive mechanism 103 is connected. In this manner, a further possibility is made available to adapt the position for the user.

[0024] Lastly, the figure shows the drive means, in the form of a pneumatic jack 118 hinged at one end to the base plate 101, in a central position, and, at the other end, connected to a rod 119 that joins the two sliders 111 transversally at the lower ends of the second arms 106, being pivotable with respect to said arms. Clearly, the retraction of the jack 118 corresponds to a pulling action on rod 119 in a frontal direction, resulting in the elevation of the seat 2 to the open configuration. On the other hand, when the jack 118 is extended, the seat reverts to the closed configuration. The actuator is connected to a pneumatic circuit controlled by an electric pump, or alternatively, manually operated.

[0025] With regard to the drive system, as mentioned, numerous alternatives can be provided. One of these is illustrated in figure 5, wherein the operating means are composed of a rear pantograph 120 that extends between the base 101 and the seat 102 in such a manner that it commands the lifting and lowering of said seat by means of its own closing/opening movement. The movement performed by the pantograph 120 is, in fact, controlled by a worm screw system (not illustrated) which works in correspondence to the connection to the base 101. The rotation of the screw, driven by a motor, causes the mutual contraction or extension movement of the two lower ends of the pantograph, and in a consequential manner, also of the two upper ends attached to the seat 102 by means of hinges 121 and a prismatic guide 122. The approaching corresponds to the closure of the pantograph and therefore to its extension in height, pushing the seat 102 in an upward direction. Vice versa, the distancing movement induces a lowering action to the closed configuration of the device. A worm screw system can also be used to act directly on one or both sliders

111 at the lower end of the second arms 106.

[0026] A further alternative, for example, can also be the use of an inflatable cushion which, when inserted between the base and seat, through the inflation, generates the upward thrust action necessary to lift and support the seat while the user is still seated. Because of the kinematics described above, this thrust action will result in the various motion components of the seat. A small electric or manually operated pump is sufficient to inflate the air cushion. Again, alternatively, and by no means in a limiting manner, other purely mechanical means can be applied, such as a system using steel wires that pull the rod 119 (figure 4) from opposite directions and in a coordinated manner, controlled by motorized winding means.

[0027] The invention therefore provides for a seat assist device for disabled persons, or more generally, for those who have problems with lower limbs, wherein the seat is equipped with an elevation system that permits the user to perform a movement that is very close to a natural movement. The barycentre of the person follows a course that prevents loss of balance during the lifting action, protecting the bone-muscular structure from excessive overloading caused by unnatural movement, and, at the same time, reducing the force that is necessary to the lifting action. This result is achieved with extremely simple mechanical solutions, and therefore also with low production and maintenance costs, as well as with no drawbacks in relation to bulk and weight. In fact, the device has a size and compactness that make it possible and simple to install it on the seat of any type of chair or armchair, or as a replacement for an existing cushion.

[0028] The terms "horizontal", "vertical", "front", "rear" and similar expressions, used in the present description, obviously refer to the device when positioned on the sitting plane of a conventional chair or armchair, said plane being substantially parallel to the ground, and therefore in the position of normal use. The seat surface 2a on seat 2 can consist of an actual material plane surface, as shown in the example, or an imaginary plane as a result of a linear interpolation or of an envelope plane of a concave or generally undulated surface, and that represents the support with which said surface is schematically representable.

[0029] Numerous variants and/or modifications can be brought to the seat assist device for the elderly and disabled according to the present invention without departing from the scope of the invention itself as defined by the appended claims.

Claims

1. A seat assist device comprising: a base (1) having a support surface (1a) to be positioned on the seat surface of a chair, armchair or the like; a seat (2) defining a seat surface (2a) with a front side (2b),

- said seat (2) being movable between a closed configuration, wherein said seat (2) is adjacent to the base (1) with said seat surface (2a) substantially horizontal, and an open configuration, wherein the seat (2) is lifted in relation to the base (1) to assist the assumption of a standing position by a user sitting on the seat (2) with the legs projecting over said front side (2b); connection means (3) connecting said seat (2) and said base (1) for ensuring the motion of said seat (2) between said open and closed configurations; and drive means for driving said motion, said connection means (3) comprising articulation means (4), for bringing said seat (2) in said open configuration in a position which is translated in relation to said base (1), both vertically and horizontally in a frontal direction, and at the same time tilted with the front side in a downward direction, said articulation means (4) comprising first articulation means (5) pivotally connected to said base (1) and said seat (2), and second articulation means (6), hinged to said first articulation means (5) and pivotally and slidingly connected to said seat (2) and said base (1), along guide means (13,12) respectively arranged on said seat (2), parallel to said seat surface (2a), and on said base (1), **characterized in that** said first and second articulation means (5, 6) comprise at least one pair of crossed-over arms (5, 6), arranged on a plane substantially orthogonal to said seat surface (2a), a first arm (5) extending obliquely between the front side (1a) of said base (1) and the rear area of said seat (2), and a second arm (6) extending obliquely between the front side (2b) of said seat (2) and the rear side of said base (1).
2. The device according to claim 1, comprising two pairs of arms (5, 6) each arranged on a lateral side substantially orthogonal to said front side (1a, 2b).
 3. The device according to claim 1 or 2, wherein said guide means (12, 13) of said second arm (6) comprise guide grooves (13, 12) formed in said seat (2) and in said base (1), said second arm (6) comprising end sliders (11, 10) slidingly engaged in said grooved.
 4. The device according to any of the claims from 1 to 3, wherein said guide means (12) for said second arm (6) are formed in said base (1) so as to extend in a horizontal direction.
 5. The device according to any of the claims from 1 to 3, wherein said guide means (112) for said second arm (106) formed in said base (101) comprise at least one segment extending obliquely in an upward frontal direction.
 6. The device according to any of the claims from 1 to 5, wherein said first arm is hinged directly to said seat (2) on the rear side (2d).
 7. The device according to any of the claims from 1 to 5, wherein said first articulation means (105) comprise, in addition to said first arm (105), a tie rod (115) extending between said first arm (105) and said seat (102) substantially parallel to said second arm (106), said tie rod (115) being hinged to said seat (102) and to said first arm (105) at the upper end, the latter making contact with guide means (109) integral with said seat (2) and substantially parallel to said seat surface (102a).
 8. The device according to claim 7, wherein said tie rod (115) is replaced by a guide cam which, on said seat (102), acts as a guiding element for a slider attached to said second arm (106).
 9. The device according to any of the claims from 1 to 8, wherein one or more of said arms (105, 106) present a structure adjustable in length.
 10. The device according to any of the claims from 2 to 9, comprising a rod (119) that transversally joins the lower ends of said second arms (106), pivotable in relation thereto, said drive means (118) acting on said rod (119) for controlling its forward-backward motion.
 11. The device according to claim 10, wherein said drive means comprise a pneumatic jack (118) hinged at one end to said base (101), in a central position, and at the other end connected to said rod (119), said jack (118) being controlled by a pneumatic circuit commanded by an electric or manually operated pump.
 12. The device according to claim 10, wherein said drive means comprise cable means for pulling said rod (119) from opposite directions and in a coordinated manner, controlled by motorized winding means.
 13. The device according to any of the claims from 2 to 9, wherein said drive means comprise a pantograph (120) extending at the rear between said base (101) and said seat (102) so as to command by its opening/closing action the lifting and lowering of said seat, the motion of the pantograph (120) being controlled by worm screw means that operate on the ends of the pantograph (120) connected to the base (101), the two upper ends of the pantograph being engaged with the seat (102) by hinges and prismatic guide means (121, 122).
 14. The device according to any of the claims from 2 to 9, wherein said drive means comprise worm screw means operating directly on one or both the sliders (10, 110) at the lower ends of said second arms (6,

106).

15. The device according to any of the claims from 2 to 9, wherein said drive means comprise an inflatable cushion inserted between the base (1) and the seat (2), for generating the thrust in an upward direction necessary to lift and support the seat while the user is in a sitting position on it, electric or manually operated pump means being provided for inflating said cushion.
16. The device according to any of the previous claims, wherein said seat (2) comprises a sliding seat plane, movable in a backward and forward direction, with a certain degree of resistance, with respect to an underlying structure with which the connecting means (3) between the same seat and the base are engaged.

Patentansprüche

1. Sitzhilfsvorrichtung, enthaltend: eine Basis (1), die eine Halteoberfläche (1a) hat, um auf der Sitzoberfläche eines Stuhls, Sessels oder ähnlichem positioniert zu werden; einen Sitz (2), der eine Sitzoberfläche (2a) mit einer Vorderseite (2b) definiert, wobei der Sitz (2) zwischen einer geschlossenen Konfiguration, in der der Sitz (2) benachbart der Basis (1) mit der Sitzoberfläche (2a) im Wesentlichen horizontal ist, und einer offenen Konfiguration beweglich ist, in der der Sitz (2) in Relation zu der Basis (1) angehoben ist, um das Einnehmen einer stehenden Position durch einen Anwender, der mit den Beinen über die Vorderseite (2b) vorstehend auf dem Sitz (2) sitzt, zu unterstützen; Verbindungseinrichtungen (3), die den Sitz (2) und die Basis (1) verbinden, um die Bewegung des Sitzes (2) zwischen den offenen und geschlossenen Konfigurationen sicher zu stellen; und Antriebseinrichtungen zum Antreiben der Bewegung, wobei die Verbindungseinrichtungen (3) Artikulationseinrichtungen (4) enthalten, um den Sitz (2) in der offenen Konfiguration in eine Position zu bringen, die in Relation zu der Basis (1) sowohl vertikal als auch horizontal in einer Frontalrichtung verschoben und gleichzeitig mit der Vorderseite in eine Abwärtsrichtung geneigt ist, wobei die Artikulationseinrichtungen (4) erste Artikulationseinrichtungen (5), die gelenkig mit der Basis (1) und dem Sitz (2) verbunden sind, und zweite Artikulationseinrichtungen (6) enthalten, die an dem ersten Artikulationseinrichtungen (5) angelenkt sind und mit dem Sitz (2) und der Basis (1) gelenkig und längs Längsführungseinrichtungen (13, 12) verschiebbar verbunden sind, die entsprechend an dem Sitz (2) parallel zu der Sitzoberfläche (2a) und an der Basis (1) angeordnet sind, **dadurch gekennzeichnet, dass** die ersten und zweiten Artikulationseinrichtungen (5, 6)

wenigstens ein Paar von gekreuzten Armen (5, 6) enthalten, die in einer Ebene im Wesentlichen orthogonal zu der Sitzoberfläche (2a) angeordnet sind, wobei sich ein erster Arm (5) schräg zwischen der Vorderseite (1a) der Basis (1) und dem hinteren Bereich des Sitzes (2) erstreckt und sich ein zweiter Arm (6) schräg zwischen der Vorderseite (2b) des Sitzes (2) und der Rückseite der Basis (1) erstreckt.

2. Vorrichtung nach Anspruch 1, wobei zwei Paare von Armen (5, 6) enthalten sind, die jeweils an einer seitlichen Seite im Wesentlichen orthogonal zu der Vorderseite (1a, 2b) angeordnet sind.
3. Vorrichtung nach Anspruch 1 oder 2, wobei die Führungseinrichtungen (12, 13) des zweiten Arms (6) Führungsnute (13, 12) enthalten, die in dem Sitz (2) und in der Basis (1) ausgebildet sind, wobei der zweite Arm (6) Endschieber (11, 10) enthält, die verschiebbar in den Nuten in Eingriff sind.
4. Vorrichtung nach einem der Ansprüche 1 bis 3, wobei die Führungseinrichtungen (12) für den zweiten Arm (6) in der Basis (1) ausgebildet sind, um sich in einer horizontalen Richtung zu erstrecken.
5. Vorrichtung nach einem der Ansprüche 1 bis 3, wobei die in der Basis (101) ausgebildeten Führungseinrichtungen (112) für den zweiten Arm (106) wenigstens ein Segment enthalten, das sich schräg in einer aufwärts gerichteten Frontalrichtung erstreckt.
6. Vorrichtung nach einem der Ansprüche 1 bis 5, wobei der erste Arm direkt an dem Sitz (2) an der Rückseite (2d) angelenkt ist.
7. Vorrichtung nach einem der Ansprüche 1 bis 5, wobei die ersten Artikulationseinrichtungen (105) zusätzlich zu dem ersten Arm (105) eine Gelenkstange (115) enthalten, die sich zwischen dem ersten Arm (105) und dem Sitz (102) im Wesentlichen parallel zu dem zweiten Arm (106) erstreckt, wobei die Gelenkstange (115) an dem Sitz (102) und an dem ersten Arm (105) an dem oberen Ende angelenkt ist, wobei das letztere einen Kontakt mit Führungseinrichtungen (109) herstellt, die integral mit dem Sitz (2) und im Wesentlichen parallel zu der Sitzoberfläche (102a) sind.
8. Vorrichtung nach Anspruch 7, wobei die Gelenkstange (115) durch einen Führungsmitnehmer ersetzt ist, der an dem Sitz (102) als ein Führungselement für einen Schieber wirkt, der an dem zweiten Arm (106) angebracht ist.
9. Vorrichtung nach einem der Ansprüche 1 bis 8, wobei einer oder mehrere der Arme (105, 106) eine in der Länge einstellbare Struktur bietet/-n.

10. Vorrichtung nach einem der Ansprüche 2 bis 9, enthaltend eine Stange (119) die transversal an die unteren Enden des zweiten Arms (106) in Relation dazu gelenkig anschließt, wobei die Antriebseinrichtungen (118) auf die Stange (119) wirken, um ihre Vorwärts-Rückwärts-Bewegung zu steuern.
11. Vorrichtung nach Anspruch 10, wobei die Antriebseinrichtungen eine pneumatisch Buchse (118) enthalten, die an einem Ende an der Basis (101) in einer zentralen Position angelenkt und an dem anderen Ende mit der Stange (119) verbunden ist, wobei die Buchse (118) durch eine Pneumatikschaltung gesteuert wird, die von einer elektrisch oder manuell betätigten Pumpe befehligt wird.
12. Vorrichtung nach Anspruch 10, wobei die Antriebseinrichtungen Kabeleinrichtungen enthalten, um die Stange (119) gesteuert aus entgegengesetzten Richtungen und in einer koordinierten Weise durch motorisierte Wickeleinrichtungen zu ziehen.
13. Vorrichtung nach einem der Ansprüche 2 bis 9, wobei die Antriebseinrichtungen einen Pantographen (120) enthalten, der sich an der Rückseite zwischen der Basis (101) und dem Sitz (102) erstreckt, um durch seine Öffnen-Schließen-Aktion das Anheben und Absenken des Sitzes zu befehlen, wobei die Bewegung des Pantographen (120) durch Schnecken-schraubeneinrichtungen gesteuert wird, die an den Enden des Pantographen (120) mit der Basis (101) verbunden arbeiten, wobei die zwei oberen Enden des Pantographen mit dem Sitz (102) durch Gelenke und prismatische Führungseinrichtungen (121, 122) in Eingriff sind.
14. Vorrichtung nach einem der Ansprüche 2 bis 9, wobei die Antriebseinrichtungen Schnecken-schraubeneinrichtungen enthalten, die direkt auf einen oder beide der Schieber (10, 110) an den unteren Enden des zweiten Arms (6, 106) wirken.
15. Vorrichtung nach einem der Ansprüche 2 bis 9, wobei die Antriebseinrichtungen ein aufblasbares Kissen enthalten, das zwischen die Basis (1) und den Sitz (2) eingesetzt ist, um den Druck in einer Aufwärtsrichtung zu erzeugen, der erforderlich ist, den Sitz anzuheben und zu halten, während der Anwender in einer darauf sitzenden Position ist, wobei elektrisch oder manuell betätigte Pumpeinrichtungen zum Aufblasen des Kissens vorgesehen sind.
16. Vorrichtung nach einem der vorhergehenden Ansprüche, wobei der Sitz (2) eine Schiebesitzzebene enthält, die in einer Rückwärts- und Vorwärtsrichtung mit einem bestimmten Grad an Widerstand bezüglich einer Unterlagenstruktur beweglich ist, mit welcher die Verbindungseinrichtungen (3) zwischen

dem Sitz und der Basis in Eingriff sind.

Revendications

1. Un dispositif d'assistance pour s'asseoir comprenant : une embase (1) ayant une surface de support (1a) pour être positionnée sur la surface d'assise d'une chaise, d'un fauteuil ou analogue ; un siège (2) définissant une surface d'assise (2a) avec un côté avant (2b), ledit siège (2) étant mobile entre une configuration fermée, où ledit siège (2) est adjacente à l'embase (1) avec ladite surface d'assise (2a) sensiblement horizontale, et une configuration ouverte, où le siège (2) est soulevé par rapport à l'embase (1) pour aider à l'ascension vers une position debout d'un utilisateur assis sur le siège (2) avec les jambes se projetant au-dessus du dit côté avant (2b) ; des moyens de liaison (3) reliant ledit siège (2) et ladite embase (1) pour assurer le mouvement du dit siège (2) entre lesdites configurations ouverte et fermée ; et des moyens de commande pour commander ledit mouvement, lesdits moyens de liaison (3) comportant des moyens d'articulation (4), pour amener ledit siège (2) dans ladite configuration ouverte dans une position qui est translatée par rapport à ladite embase (1), à la fois verticalement et horizontalement en direction vers l'avant, et en même temps inclinée par rapport au côté avant suivant une direction descendante, lesdits moyens d'articulation (4) comportant des premiers moyens d'articulation (5) montés pivotant sur ladite embase (1) et sur ledit siège (2), et des seconds moyens d'articulation (6), articulés sur lesdits premiers moyens d'articulation (5) et reliés de façon pivotante et coulissante au dit siège (2) et à ladite embase (1), le long de moyens de guidage (13, 12) respectivement agencés sur ledit siège (2), parallèlement à ladite surface d'assise (2a), et sur ladite embase (1), **caractérisé en ce que** lesdits premiers et seconds moyens d'articulation (5, 6) comportent au moins une paire de bras en croix (5, 6), agencés dans un plan sensiblement orthogonal à ladite surface d'assise (2a), un premier bras (5) s'étendant de façon oblique entre le côté avant (1a) de ladite embase (1) et la zone arrière du dit siège (2), et un second bras (6) s'étendant de façon oblique entre le côté avant (2b) du dit siège (2) et le côté arrière de ladite embase (1).
2. Le dispositif selon la revendication 1, comportant deux paires de bras (5, 6) chacune agencée sur un côté latéral sensiblement orthogonal au dit côté avant (1a,2b).
3. Le dispositif selon l'une des revendications 1 et 2, où lesdits moyens de guidage (12, 13) du dit second bras (6) comportent des rainures de guidage (13,

- 12) réalisées dans ledit siège (2) et dans ladite embase (1), ledit second bras (6) comportant des coulisses d'extrémité (11, 10) montées coulissantes dans lesdites rainures.
4. Le dispositif selon l'une quelconque des revendications 1 à 3, où lesdits moyens de guidage (12) pour le second bras (6) sont réalisés dans ladite embase (1) de façon à s'étendre dans une direction horizontale.
 5. Le dispositif selon l'une quelconque des revendications 1 à 3, où lesdits moyens de guidage (112) pour ledit second bras (106) réalisés dans ladite embase (101) comportent au moins un segment s'étendant obliquement dans une direction frontale montante.
 6. Le dispositif selon l'une quelconque des revendications 1 à 5, où ledit premier bras est directement articulé sur ledit siège (2) sur le côté arrière (2d).
 7. Le dispositif selon l'une quelconque des revendications 1 à 5, où lesdits premiers moyens d'articulation (105) comportent, en plus du dit premier bras (105), une tige de renfort (115) s'étendant entre ledit premier bras (105) et ledit siège (102) de façon sensiblement parallèle au dit second bras (106), ladite tige de renfort (115) étant articulée sur ledit siège (102) et sur ledit premier bras (105) à l'extrémité supérieure, ce dernier faisant contact avec des moyens de guidage (109) solidaires du dit siège (2) et sensiblement parallèles à ladite surface d'assise (1 02a).
 8. Le dispositif selon la revendication 7, où ladite tige de renfort (115) est remplacée par une came de guidage qui, sur ledit siège (102), agit en tant qu'élément de guidage pour une coulisse liée au dit second bras (106).
 9. Le dispositif selon l'une quelconque des revendications 1 à 8, où un ou plusieurs des dits bras (105, 106) présentent une structure réglable en longueur.
 10. Le dispositif selon l'une quelconque des revendications 2 à 9, comportant une barre (119) qui joint transversalement les extrémités inférieures des dits seconds bras (106), montée pivotante par rapport à eux, lesdits moyens de commande (118) agissant sur ladite barre (119) pour commander son mouvement avant-arrière.
 11. Le dispositif selon la revendication 10, où lesdits moyens de commande comportent un vérin pneumatique (118) articulé sur une extrémité de ladite embase (101), dans une position centrale, et sur l'autre extrémité reliée à ladite barre (119), ledit vérin (118) étant commandé par un circuit pneumatique commandé par une pompe actionnée électrique-
- ment ou manuellement.
12. Le dispositif selon la revendication 10, où lesdits moyens de commande comportent des moyens de câble pour tirer sur ladite barre (119) selon des directions opposées et d'une façon coordonnée, commandés par des moyens d'enroulement motorisés.
 13. Le dispositif selon l'une quelconque des revendications 2 à 9, où lesdits moyens de commande comportent un pantographe (120) s'étendant à l'arrière entre ladite embase (101) et ledit siège (102) afin de commander par son action ouverture/fermeture le relevage et l'abaissement du dit siège, le mouvement du pantographe (120) étant commandé par des moyens de vis sans fin qui agissent sur les extrémités du pantographe (120) reliées à l'embase (101), les deux extrémités supérieures du pantographe étant montées en coopération avec le siège (102) grâce à des charnières et des moyens de guidage prismatique (121, 122).
 14. Le dispositif selon l'une quelconque des revendications 2 à 9, où lesdits moyens de commande comportent des moyens de vis sans fin agissant directement sur au moins l'une des deux coulisses (10, 110), aux extrémités inférieures des dits seconds bras (6, 106).
 15. Le dispositif selon l'une quelconque des revendications 2 à 9, où lesdits moyens de commande comportent un coussin gonflable inséré entre l'embase (1) le siège (2), pour engendrer la poussée dans une direction ascendante nécessaire pour soulever et soutenir le siège lorsque l'utilisateur est en position assise sur lui, des moyens de pompe actionnés électriquement ou manuellement étant prévus pour gonfler ledit coussin.
 16. Le dispositif selon l'une quelconque des revendications précédentes, où ledit siège (2) comporte un plan de siège coulissant, mobile en direction arrière/avant, avec un certain degré de résistance, par rapport à une structure de base avec laquelle sont montés en coopération les moyens de liaison (3) entre ce même siège et l'embase.

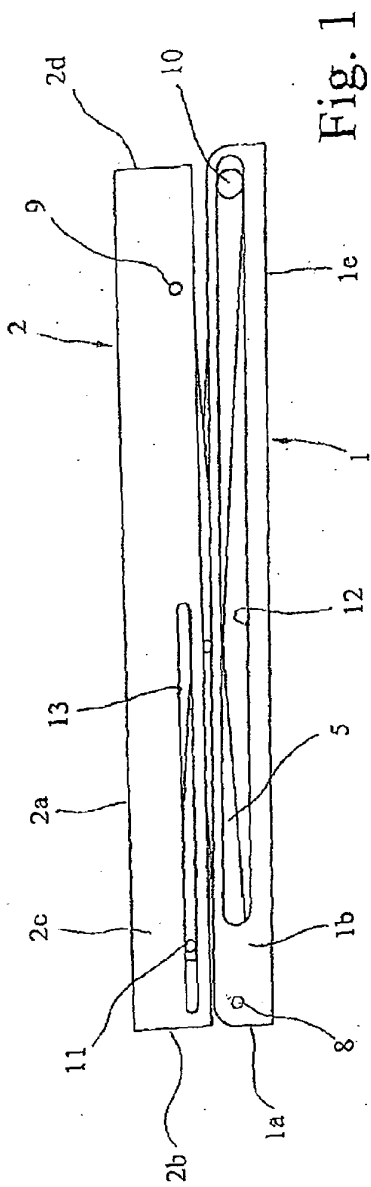

Fig. 1

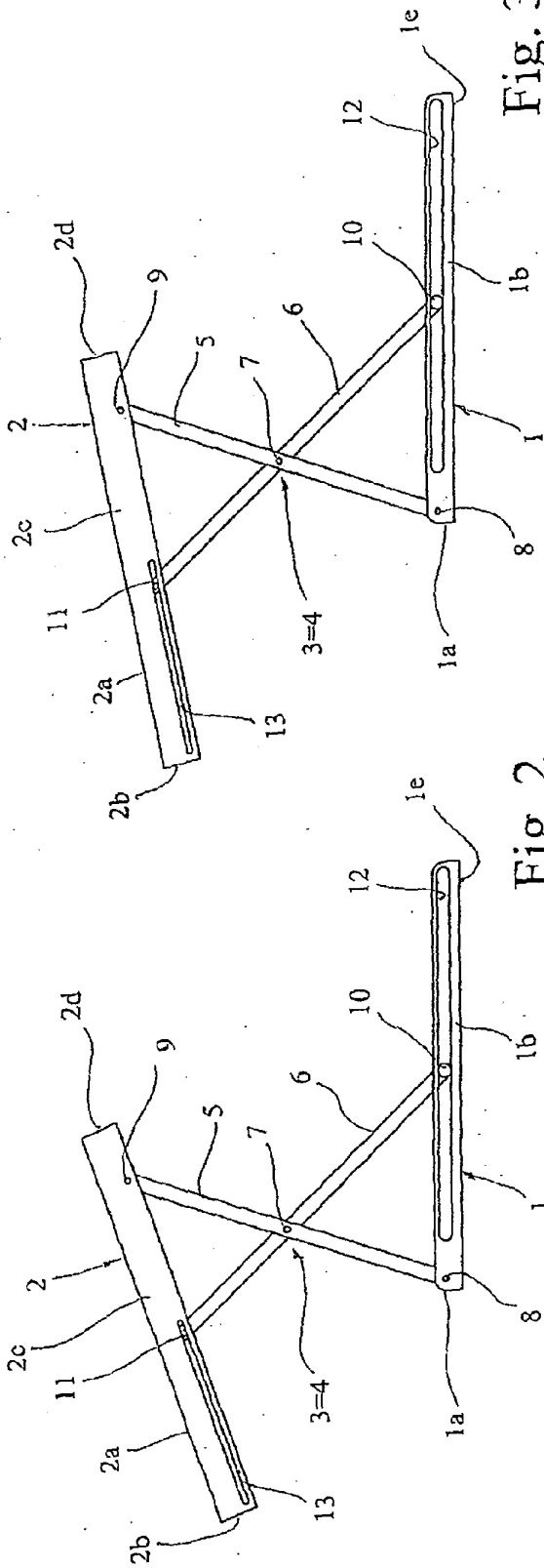

Fig. 2

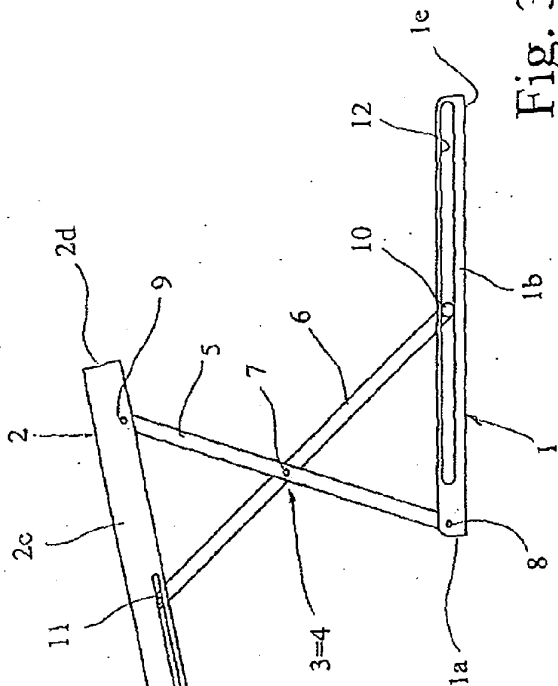

Fig. 3

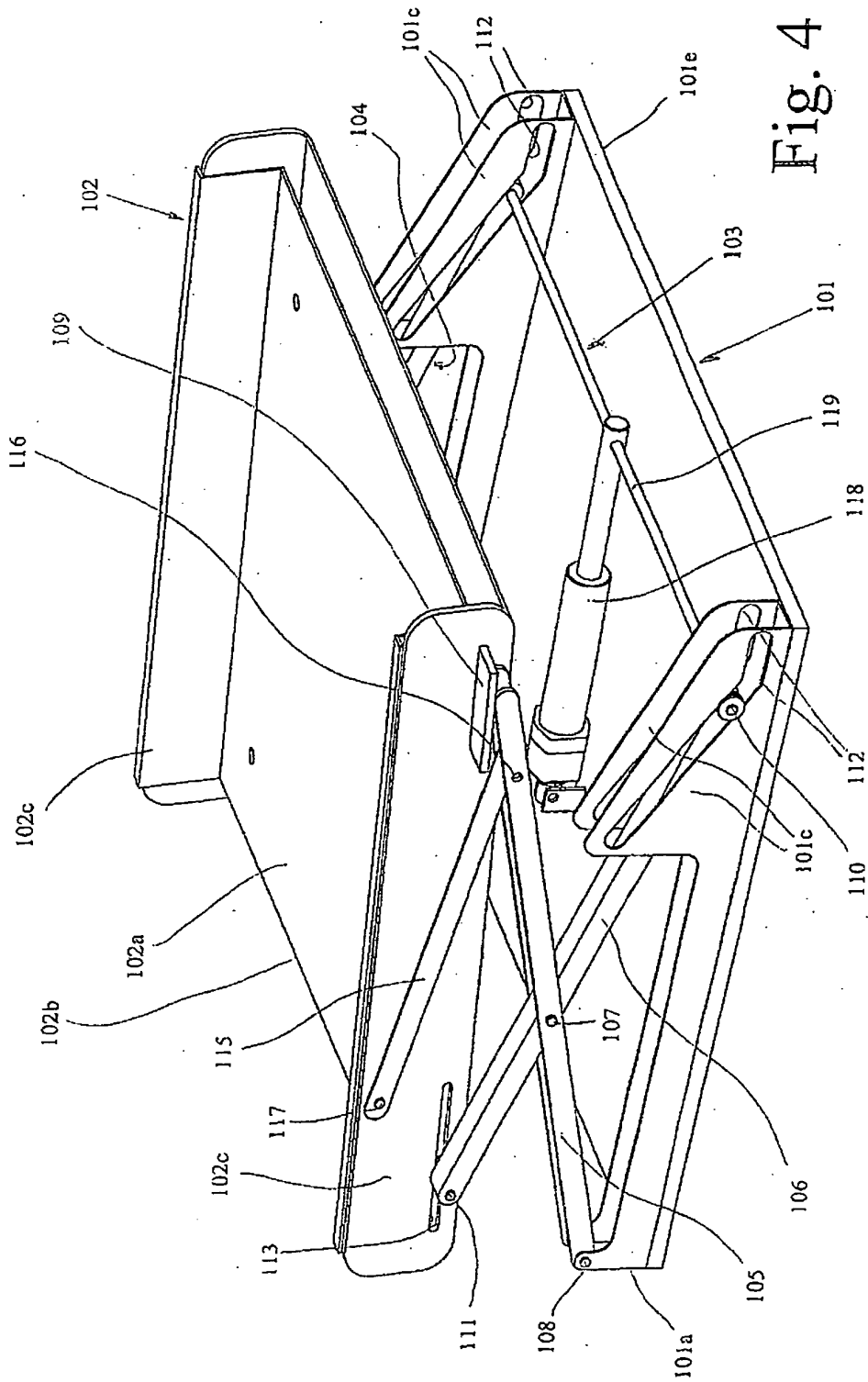

Fig. 4

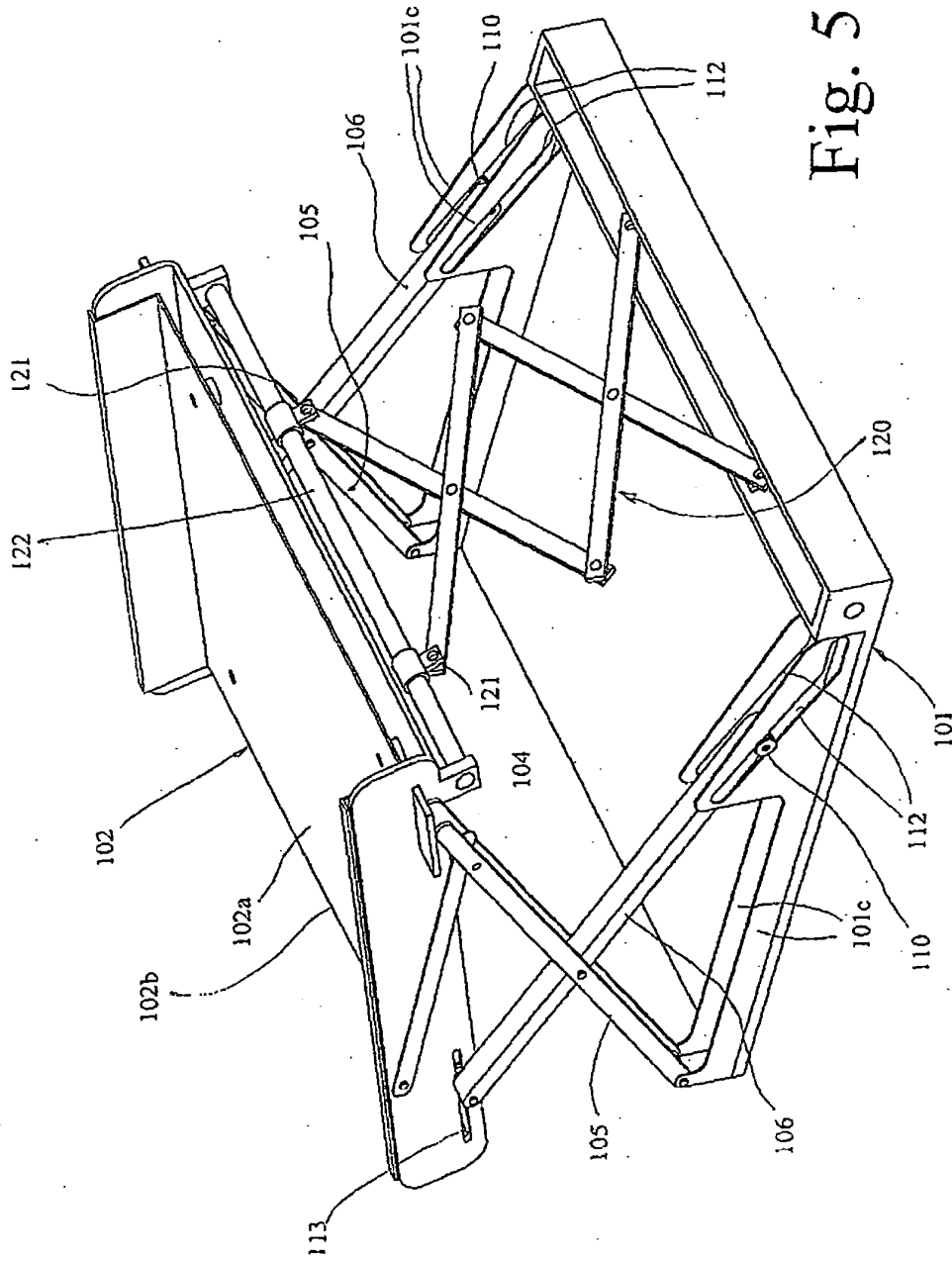

Fig. 5

EP 1 913 918 B1

REFERENCES CITED IN THE DESCRIPTION

This list of references cited by the applicant is for the reader's convenience only. It does not form part of the European patent document. Even though great care has been taken in compiling the references, errors or omissions cannot be excluded and the EPO disclaims all liability in this regard.

Patent documents cited in the description

- EP 1310227 A [0007]
- US 5316370 A [0007]
- DE 4408458 [0008]