

OXYGEN CONSUMPTION AT DIFFERENT TEMPERATURES IN YOY CRAYFISH: A COMPARISON BETWEEN INDIGENOUS AND INVASIVE SPECIES

ANNALISA PAGLIANTI¹, GIUSEPPE MESSANA² AND FRANCESCA GHERARDI¹

¹UNIVERSITÀ DI FIRENZE, ITALY

²CONSIGLIO NAZIONALE DELLE RICERCHE, ISTITUTO PER LO STUDIO DEGLI ECOSISTEMI, ITALY

ABSTRACT

A flow-through respirometer was used to determine oxygen uptake rates at the temperatures of 16, 20 and 24 °C in YOY crayfish of the indigenous *Austropotamobius pallipes* and the invasive *Procambarus clarkii*. In the former species, oxygen uptake increased with temperature, whereas the standard metabolism of *P. clarkii* showed to be lowly thermally dependent, at least within the analysed temperatures. *Procambarus clarkii*'s lower metabolic sensitivity towards temperature favours its ability to survive thermal stresses and is one of the biological features that explain this species' invasive potential.

Key words: *Austropotamobius pallipes*, *Procambarus clarkii*, young of the year, oxygen consumption, temperature

INTRODUCTION

Among poikilotherms, temperature is one of the most important environmental factors, acting directly upon metabolism, and displaying great variability in space and time. As known, temperature controls the rate of chemical reactions and regulates energy liberation and growth and activity of organisms.

Activity and metabolism vary with temperature in approximate agreement with the principle of Arrhenius that shows a logarithmic increase with temperature (Prosser 1991). Oxygen uptake is usually considered the most convenient and relevant measure of metabolic responses to temperature. An increase in temperature typically increases the oxygen uptake rate. However, metabolism of a wide variety of invertebrates not only fails to follow the relationship expressed by Arrhenius' equation but is maintained at a relatively constant value over much of the environmental temperature range that they normally experience (Newell & Northcroft 1967, Vernberg & Vernberg 1972, Newell 1976 and more recent Bückle et al. 1994, Gutiérrez-Yurrita 2000). This response is adaptive, since metabolic activity is approximately constant around optimal values. If metabolism becomes too low with a decrease in temperature, animals cannot be active and feed; on the contrary, if metabolism becomes too high with an increase in temperature, animals will dissipate energy and they are not able to supply their energy demands by eating (Vernberg & Vernberg 1982). Temperature-metabolic curves and the biogeographical distribution of a species are closely correlated (Vernberg 1962), and the observed differences in metabolic responses are either genetically, environmentally induced, or are reflecting the physiological history of individuals (Gutiérrez-Yurrita & Montes 1998, 1999).

¹ Corresponding author address: Dipartimento di Biologia Animale e Genetica "Leo Pardi", Università di Firenze. Via Romana 17, 50125 Firenze, Italy. E-mail: gherardi@DBAG.UNIFI.IT

This work aims at comparing the effect of temperature on the metabolic demand in young of the year (YOY) of two species of freshwater crayfish, the indigenous *Austropotamobius pallipes* Lereboullet and the non-indigenous, and invasive, *Procambarus clarkii* Girard. Our expectation is to identify possible metabolic features that make *P. clarkii* more competitive and to contribute to an explanation of its invasive potentials.

MATERIALS AND METHODS

Oxygen uptake rates of *A. pallipes* and *P. clarkii* YOY were determined at the temperatures of 16, 20, and 24 °C using a flow-through respirometer. Prior to the experimentation, crayfish were maintained for three-month at the three temperatures as above and were fed on earthworms. The photoperiod was 12L:12D (light phase, 07:00-19:00 h). Five crayfish for both species were tested at each exposure temperature after having been starved for five days. The volume of the respirometer chamber was small enough to impede any movement to crayfish. Experiments were run under light and between 9:00 and 17:00 hours. The "standard" rates of oxygen uptake of starved inactive animals were measured. This measure provides an estimation of energy expenditure for maintenance metabolism alone.

A scheme of the flow-through respirometer used for the measurement of the oxygen uptake is shown in Figure 1. This was designed according to the scheme of Gnaiger (1983). Driven by a peristaltic pump (PP) generating an 810 mlh^{-1} flow; water was sucked from a water reservoir (R) through the animal chamber (AC) and, in a parallel circuit, through a control chamber (CC) with the same volume but without crayfish. The small volume of the respirometer chamber allowed a good time resolution of the response. Water flow then passed two polarographic cells (E1 and E2). The probes were lodged in plexiglas cylinders dipped in a thermostatic bath. Since the volume of the measuring chamber at the tip of the electrode was very small, the water exchange was very rapid and no stirring was necessary. A four-way valve (V) was situated between the chambers and the probes. By turning the valve by 90° , every 15 minutes, the water coming from the chambers can be directed to alternate electrodes, thus pO_2 in the animal and in the control chamber can be monitored by the same electrode (Lampert 1986). The measured oxygen value was recorded by a plotter (P) regulated with a paper sliding speed of 1 mm per minute. From the tracing on paper we obtained readings every 5 min on each electrode.

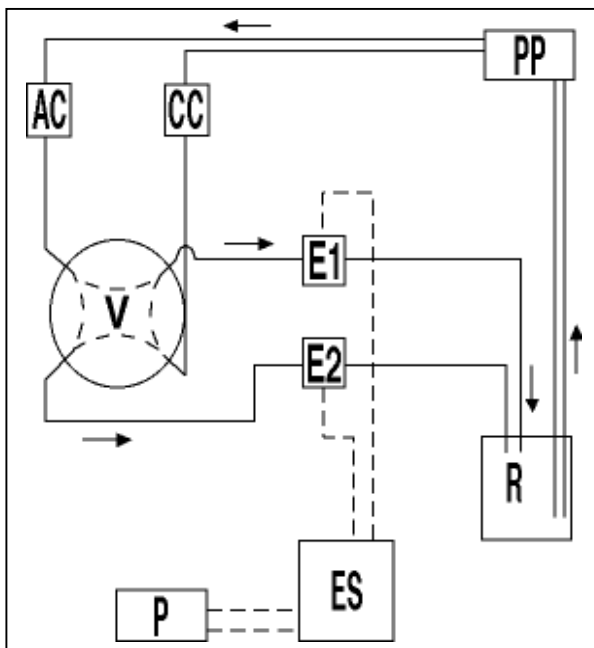

Figure 1. Scheme of the flow-through respirometer used in the present study. *R* reservoir of water; *AC* animal chamber; *CC* control chamber without crayfish; *V* four-way valve; *E1* and *E2* oxygen electrodes; *PP* peristaltic pump; *ES* electronic system; *P* plotter. Arrows show the direction of the water flux.

Oxygen uptake was estimated as the difference between the average pO_2 measured in the control chamber, in each 15 minutes interval, and the average pO_2 revealed, by the same probe, in the animal chamber during previous and successive intervals. Each experimental session lasted three hours, but the first hour was excluded from our analyses. We calculated oxygen uptake comparing measurements obtained with the same electrode in different times (with or without crayfish), rather than with different probes at the same time, to avoid the inclusion in our analysis of differences simply due to the probes.

At the end of each experimental session every crayfish was weighted to calculate oxygen uptake per unit wet weight. Before weighing, crayfish were gently dried to remove excess water by pressing them onto a piece of absorbent paper. We weighed every crayfish five times to the nearest 0.001 g using an electronic balance (TRACK mod. BC150): maximum and minimal weights were discarded and the average of the three other values was computed. Average weights of *A. pallipes* and *P. clarkii* were 1.844 g (± 0.076) and 4.006 g (± 0.185), respectively.

The statistical tests we used were a Pearson correlation test and a one-way ANOVA. *P* values of less than 0.05 were considered statistically significant.

RESULTS

As expected, *A. pallipes* (size range: cephalothorax length 17.4-21.2 mm, wet weight 1.45-2.74 g) oxygen uptake increased with temperature (significant positive correlation was found when data were log transformed: $r=0.549$, $df=14$, $p<0.05$); while the standard metabolism of *P. clarkii* (size range: cephalothorax length 23.0-29.5 mm, wet weight 2.60-4.88 g) showed to be lowly thermally dependent within the analysed temperatures (after log transformation $r=0.027$, $df=13$, $p>0.05$) (Figure 2).

At 24 °C, oxygen uptake was significantly higher in *A. pallipes* than in *P. clarkii* ($F=6.95$, $df=1.8$, $p<0.05$), whereas no differences were found at 16 and 20 °C ($F=0.1$, $df=1.8$, $p>0.05$; and $F=0.04$, $df=1.8$, $p>0.05$, respectively) (Figure 3).

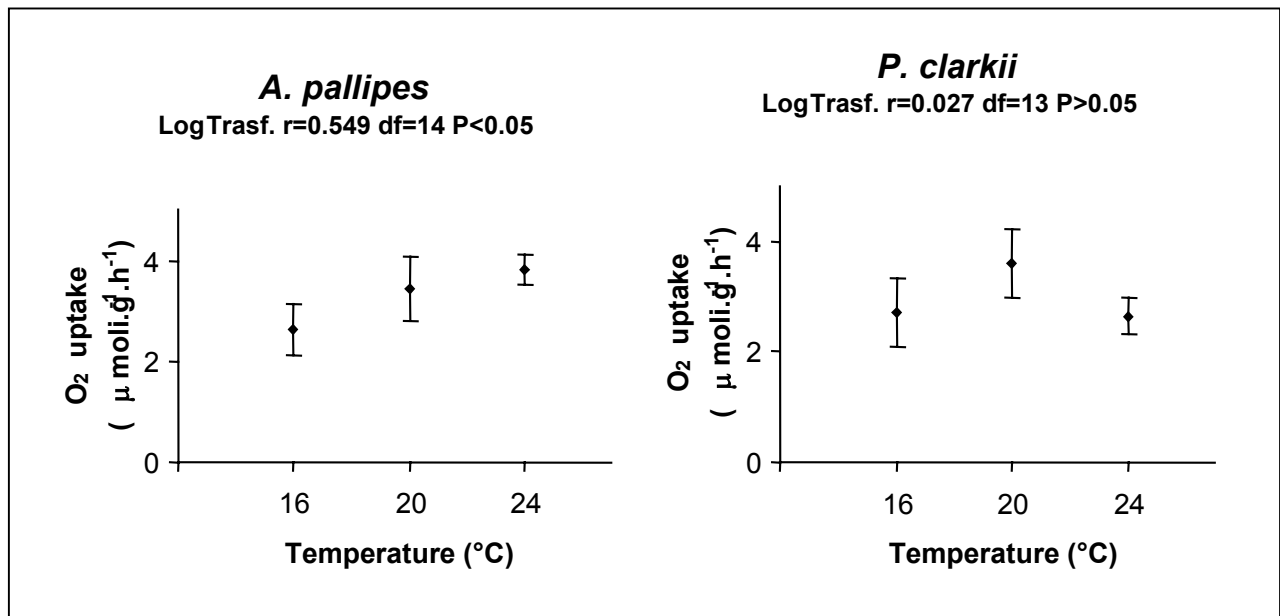

Figure 2. Relationships between oxygen uptake (\pm SE) and temperature in *Austropotamobius pallipes* and *Procambarus clarkii* YOY.

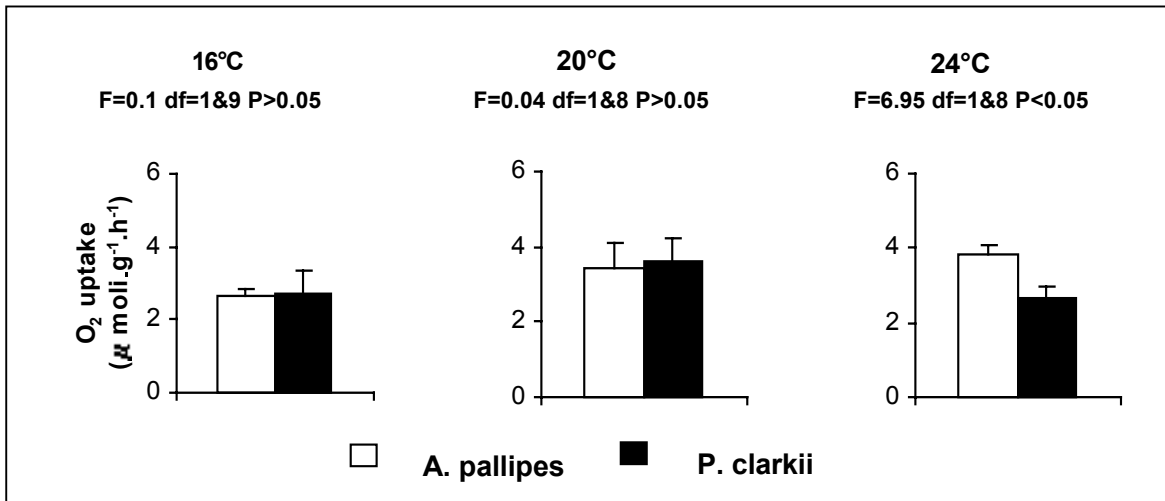

Figure 3. Oxygen uptake (\pm SE) in *Austropotamobius pallipes* and *Procambarus clarkii* YOY compared for each analysed temperature.

DISCUSSION

Within the range of temperatures analysed in the present study, *A. pallipes*' metabolism appeared to be logarithmic temperature-dependent; whereas *P. clarkii* showed metabolic insensitivity. This difference between the two species has wide ecological implications.

P. clarkii is a "warm water" species, inhabiting slow-moving waters; it is native to northeastern Mexico and the south-central USA (where during summer water temperature can reach 32 °C (data from USGS, United States Geological Survey) and recently introduced by man into southern Europe (since 1973), but mainly in freshwater marshes (Gutiérrez-Yurrita et al. 1999). *A. pallipes* is native to medium latitudes and spread in fast-moving water. As consequences of their origin and ecology, a divergence in these two species' evolutionary history may have produced significant differences in their metabolism (Vernberg 1962).

A. pallipes' higher metabolic sensitivity may act to amplify demands above a critical threshold, resulting in reduced viability at 24 °C. This species seems to have reduced potential "scope for activity" at high temperatures and the range of temperatures over which net production is maintained is narrow. Significantly faster rates of tissue wasting may also compromise its survival at high temperatures.

On the other hand, the lower energy requirement displayed by *P. clarkii* at high temperatures has a role in the conservation of energy and may permit both faster growth and higher survival rates in this species (Díaz et al. 1994, Gutiérrez-Yurrita & Montes 1999, 2001). As a consequence, the metabolic insensitivity between 16 and 24 °C appears to be an important feature of *P. clarkii*'s biology and explains its plastic behaviour, and its high adaptive metabolism to live in stressed habitats (Espino et al. 1993, Gutiérrez-Yurrita & Montes 1998). The approximate constancy in this species' metabolism between 16 and 24 °C could also signify that low temperatures do not represent a limiting factor for this invasive crayfish. As a matter of fact, Gutiérrez-Yurrita & Montes (1999, 2001), have reported that *P. clarkii* has good fitness and excellent growth rates at lower temperatures. In addition, when Gutiérrez-Yurrita (2000) compared the energy budget and associated fitness of two *P. clarkii* populations, one from a very fluctuate environment, and the other from a regular environment, no significant differences were recorded.

Examples of temperature insensitivity are available in the literature on poikilotherms, especially in those organisms living in environments subject to rapid thermal changes, such as intertidal habitats

(Newell & Northcroft 1967, Vernberg & Vernberg 1972, Newell 1976). Moreover, some freshwater fishes seem to show relatively little changes in metabolism over certain parts of the temperature range they experience (Fry, 1957). The experienced environmental temperatures may be relatively large in *P. clarkii*, since it lives in marshy habitat, it is a burrowing species, and its lifecycle is characterised by phases of activity outside the water.

Several papers by Newell and co-workers have explained those mechanisms that facilitate temperature insensitivity in poikilothermic organisms, particularly in terms of intracellular substrate concentration and membrane permeability (Newell and Bayne, 1973; Newell, 1979; Newell and Branch, 1980). Moreover, adaptive properties of enzymes seem to be involved (Prosser 1991, Hawkins 1995, Somero 1969, Hochanchka & Somero 1973, Kreider & Watts 1998).

The lower metabolic sensitivity towards temperature confers to *P. clarkii* the potential to survive thermal stresses and enhances its invasive potential (Bücker et al. 1996, Gutiérrez-Yurrita et al. 1999). Its higher performance at elevated temperatures furnishes an adaptive advantage to this species, facilitates its geographical spreading, and favours its replacement of native crayfish, as a consequence of the constant increase in temperature recorded in European inland waters due to, e.g., deforestation, reduction of water flow, and thermal pollution.

REFERENCES

- Bücker, L. F., Díaz, F., Correa, F., Barón, B. and M. Hernández. 1994. Diel thermoregulation of the crayfish *Procambarus clarkii* (Crustacea : Cambaridae). *Journal of Thermal Biology* 19, 419-422.
- Bücker, R. L. F., Díaz, H. F. and Espina S.. 1996. Thermoregulatory behavior applied to the culture of *Procambarus clarkii* (Decapoda : Cambaridae). *Revista de Biología Tropical* 44, 123-126.
- Díaz, H. F., Espina, S. y Bücker, R. L. F. 1994. Thermal stress responses of *Procambarus clarkii*. *Rivista Italiana di Acquacoltura* 29, 149-154.
- Espino, S., Díaz, H. F. and Bücker, R. L. F. 1993. Preferred and avoided temperatures in the crayfish *Procambarus clarkii*. *Decapoda, Cambaridae. Journal of Thermal Biology* 19, 1-5.
- Fry, F. E. J., 1957. The aquatic respiration of fish. In *The physiology of fishes*. 1: 1-63. Ed. Brown, M. E. New York: Academic Press.
- Gnaiger 1983. The twin flow microrespirometer and simultaneous calorimetry. In: Gnaiger, E., & H. Forstner edits. *Polarographic oxygen sensors. Aquatic and physiological applications*. Springer-Verlag, Ch. II.3 pp. 134-166.
- Gutiérrez-Yurrita, P. J. 2000. *El Papel Ecológico Del Cangrejo Rojo (Procambarus clarkii), En El Parque Nacional De Doñana. Una Perspectiva Ecofisiológica y Bioenergética*. Servicio de Publicaciones, Universidad Autónoma de Madrid, Spain. 280pp.
- Gutiérrez-Yurrita, P. J. and Montes, C. 1998. Environmental factors controlling the crayfish *Procambarus clarkii* activity in Doñana National Park temporary freshwater marsh, SW. Spain. *Comparative Biochemistry and Physiology, Part A* 120: 713-721.
- Gutiérrez-Yurrita, P. J. and Montes, C. 1999. Bioenergetics and phenology of reproduction of the introduced red swamp crayfish *Procambarus clarkii* in Doñana National Park (Spain), and implications for management. *Freshwater Biology*, 42: 561-574.
- Gutiérrez-Yurrita, P. J. and Montes, C. 2001. Bioenergetics of juveniles of red swamp crayfish (*Procambarus clarkii*). *Comparative Biochemistry and Physiology Part A*. 130 (1):29-38.
- Gutiérrez-Yurrita, P. J., Martínez, J.M., Ilhéu, M., Bravo, M.A., Bernardo, B. and Montes C. 1999. The status of crayfish populations in Spain and Portugal. (In: *Crayfish in Europe as alien species: how to make the best of a bad situation?*). Gherardi, F. and Holdich, D.M. (Eds). *Crustacean issues*. Balkema, Rotterdam/Brookfield. Pp.: 161-192.
- Hawkins, A. J. S., 1995. Effects of temperature on ectotherm metabolism and evolution : metabolic and physiological interrelations underlying the superiority of multi-locus heterozygotes in heterogeneous environments. *Journal of Thermal Biology*, 20: 23-33.
- Hochanchka, P. W., and G. N. Somero 1973. *Strategies of Biochemical Adaptation*, p. 358. Saunders, Philadelphia.

- Kreider, J.L. and Watts S.A. 1998. Behavioral (feeding) responses of the crayfish, *Procambarus clarkii*, to natural dietary items and common components of formulated crustacean feeds. *Journal of Chemical Ecology*, 24(1): 91-111.
- Lampert, W., 1986. Response of the respiratory rate of *Daphnia magna* to changing food conditions. *Oecologia* 70: 495-501.
- Newell R. C. and B. L. Bayne, 1973. A review on temperature and metabolic acclimation in intertidal marine invertebrates. *Netherlands Journal of Sea Research* 7: 421-433.
- Newell R. C. and G. M. Branch, 1980. The effects of temperature on maintenance of metabolic energy in marine invertebrates. *Advances in Marine Biology* 17: 329-396.
- Newell R. C. and H. R. Northcroft, 1967. A reinterpretation of the effect of temperature on the metabolism of certain marine invertebrates. *Journal of Zoology (London)* 151: 277-298.
- Newell R. C. 1979. *Biology of Intertidal Animals*, p. 781. Marine Ecological Surveys Ltd, Faversham.
- Newell, R. C., 1976. *Adaptations to Environment: Essays on the Physiology of Marine Animals*. Butterworth, London.
- Prosser C. L. *ed.* 1991. *Comparative animal physiology: Environmental and metabolic animal physiology* New York [etc.], Wiley-Liss.
- Somero, G. N. 1969. Enzymatic mechanism of temperature compensation: immediate and evolutionary effects of temperature on enzymes of aquatic poikilotherms. *American Naturalist* 103: 517-530.
- Vernberg, F. J., 1962. Latitudinal effects on physiological properties of animal populations. *Annual Review of Physiology* 24: 517-546.
- Vernberg, F. J., 1982. Respiratory Adaptations. In: D. E. Bliss, ed. in chief, *The biology of crustacea*. Vol. 8. F. J. Vernberg & W. B. Vernberg, ed., *Environmental Adaptations*. Pp. 1-42. Academic Press, New York, New York.
- Vernberg, W. B., & F. J. Vernberg 1972. *Environmental Physiology of Marine Animals*. Springer-Verlag, Berlin and New York.