

PLANNING AND OPTIMISATION OF THE STRATOSPHERIC GONDOLA PROJECT: SEARCH FOR A STANDARD

Federico Rotini ⁽¹⁾, Andrea Boscaleri ⁽²⁾, Massimo Baldi ⁽²⁾, Filippo Calonaci ⁽¹⁾, Paolo Rissone ⁽¹⁾

⁽¹⁾*Dipartimento di Meccanica e Tecnologie Industriali - UNIFI, via S. Marta 3, 50139 - Florence - Italy,
Email: federico.rotini@unifi.it*

⁽²⁾*IFAC-CNR, via Panciatichi 64, 50127 - Florence - Italy,
Email: a.boscaleri@ifac.cnr.it*

ABSTRACT

In this paper the authors will describe the work which the University of Florence and IFAC-CNR (Florence) have performed in order to design an innovative platform for High-latitude LDB flights based on multi-experiments and versatility concepts.

In order to satisfy the functional requirements and difficult structural constraints in terms of stiffness, strength and weight, the authors will describe an innovative approach to designing the gondola using problem-solving techniques, virtual prototyping and topology optimization in a systematic way. By means of these tools, a set of optimized geometries has been tested, starting from the first implementation of the BarSPORt experiment's platform. Some of these solutions will be described.

1. INTRODUCTION.

Over the past two decades, stratospheric experiments have undergone a constant technological upgrading both in the field of earth observation and in research on Cosmic Microwave Background anisotropies. Validation of satellite measurements, important tests of new prototypes intended to be housed in a satellite structure, as well as new self-consistent experiments, still need relatively low-cost stratospheric payloads. High-latitude LDB flights, as well as the study of those atmospheric processes that take place in remote earth regions, suggest payloads that must be smaller in volume, weight and inertia moment so that they can be launched from any site in which a balloon base can be easily set up. Reducing the power necessary for spinning either the outer frame of the platform in azimuth or the inner frame in elevation is the primary design requirement. Starting from generic design specifications such as safety factors, lightness, dynamic rigidity, minimum inertia moment, ease of transport and assembly, IFAC-CNR and the University of Florence have sought to initiate a new path in the designing of platforms, in the search for an easily reproducible standard.

Over the years, the project specifications, some of which contradict each other, has produced the

consolidated tendency to adopt constructive solutions in reticular-type layouts of large dimensions, at the expense of transportability, simplicity of construction, maneuverability in flight, and versatility in satisfying the various primary needs of different types of experiments which originate as dedicated to a single experiment. The truly innovative contribution to the design of a platform, differently from those that originate as dedicated to a single experiment, has been that of introducing the concept of versatility. This is expressed in the possibility of rapidly changing the direction of observation in subsequent flights of the same experiment. The platform of the BarSPORt experiment, which originated for High-latitude LDB flights, was the first implementation of this. The concept of the gondola in its first structure is still completely reticular; however, thanks to the use of numerical models, it has been possible to design the distribution of the solar panels over three different parts of the platform (there is a 90° distance between them), while maintaining it well-balanced with respect to the attachment point of the flight chain. This first version of the gondola fully satisfies the multi-users and multi-experiment requirements, so it may already be considered a good result. Developments of platforms will always pass through an optimisation of the layout of the gondola in order to further minimize the inertia moment with respect to the pivot axis and reduce the overall dimensions using new techniques to support the designer in the concept design phase. These tasks requires studying the spatial layout of the mass of each experiment in the gondola structure, so that both the versatility of the first concept and its functionality are preserved. An important and crucial task is now represented by the frame mass minimization for achieving the maximum useful load for each experiment without compromising the structural stiffness and strength.

As already noted, several of these specifications are in reciprocal contradiction. Therefore, the way to obtain original, more innovative and efficient solutions is to solve these contradictions by a systematic approach to the design process, using techniques that can support the designer during the concept phase. These techniques suggest possible improvements in the first-defined general architecture so that greatly efficient

constructive solutions from both a structural and a functional point of view can be achieved, which can be easily and rapidly verified through the use of numerical modelling techniques (from CAD to FEM and MultyBody Simulation). These tools can easily and rapidly carry out “what if”-type analyses for those cases which are difficult to deal with in an analytical manner, such as studies of: dynamic rigidity, pendulation, the effect of the application of dynamic shock absorbers to mobile components, and possible optimization in the choice and positioning of the flywheels necessary to the handling.

Here as follows, a detailed description of the first BarSPort experiment’s concept is provided and the systematic approach adopted in the design of new Concepts of the gondola will be presented.

2. “BARSPORT” GONDOLA EXPERIMENT: STATE OF THE ART AND MAIN FEATURES.

As mentioned in the previous section, the main features of the first approach of the BarSPort gondola concept [1] may be summarized as follows:

- **multi-experiment platform:** the frame of the gondola has overall dimensions which permit the setting up of different experiments. A sharing of pointing or scanning resources is not required, at least not at the same time;
- **versatility:** the direction of observation of the “main” experiment may be changed, according to given sky patches to be observed for a given mission, thanks to the variable positions of the solar panels. These may be mounted, in the rear, left or right side of the gondola frame, in order to increase the measurement field also located in an anti-sun direction .

Figure 1 shows the 3D parametric virtual model obtained by SOLIDWORKS rev. 2004. The subject is the result that meets certain requirements for optimizing the layout of each common component, and lets the other small experiments arranged on the same platform[2] have their own measurement field. In accordance with the Figure 1, the following are the main structural members constituting the gondola:

1. **Frame of the gondola:** This is the structure with a reticular layout within the experiments and subsystems are mechanically arranged. It is shown in Figure 2;
2. **“Spider” structure:** This is the upper part of the gondola that connects the frame to the balloon by means of a pivot device[2];

3. **Frame of the solar panels:** This is a versatile structure connecting the solar panels to one of the three sides of the gondola frame;
4. **Pivot device:** the pivot joint can house different combination of torque motors and gear boxes, and features any azimuth movements while scanning or points at any arbitrary sky target.

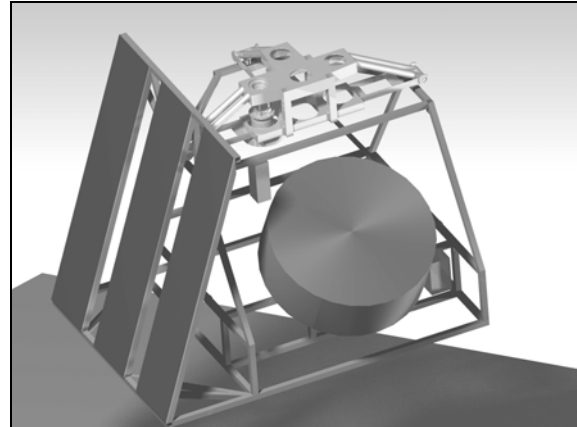

Fig. 1: 3D CAD model of the “gondola”: in this picture, the solar panels are mounted in the left side of the frame. The telescope is on the front side, while on the upper side there is the “spider” structure with four holes on which the pivot can be mounted.

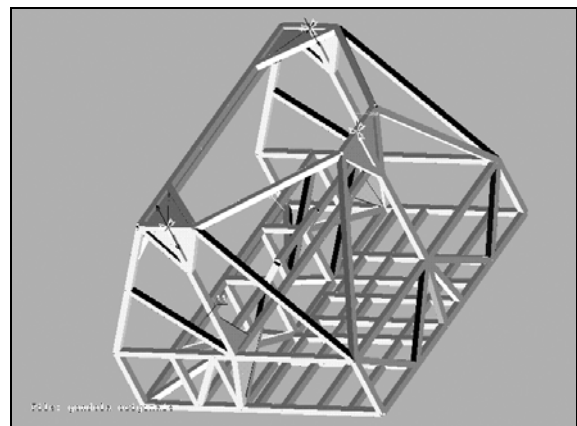

Fig. 2: The reticular layout of the gondola frame.

All these parts are manufactured using an aluminum alloy that has a tensile strength equal to 300 Mpa.

The configuration presented in the picture has the solar panels mounted on the left side of the gondola frame, while the telescope is assembled on the front side. The masses of each component of the system constituting the BarSPort “prototype” experiment are summarized in Table 1.

Table 1: mass of each component

Component	Mass (kg)
Telescope	320
Refir [3]	60
Rack	32
Solar sensor	20
Batteries	66
Solar Panels	260
Ballast	400

The telescope is assumed to have an elevation of between 30° and 60° with respect to the horizontal plane of the gondola. The mass of the solar panels, as quoted in Table 1, is relative to a maximum estimated surface equal to 12 m^2 . They are mounted with an angle of 20° with respect to the vertical plane. It is worth noting the very high value of the ballast mass needed to control the float altitude of the trajectory. This decreases the scientific loads that may be embarked!

As mentioned above, the solar panels, whose mass is considerable, may assume three different positions. This means that the center of gravity of the whole system has variable coordinates. For tracking the center of gravity movements, a primary need of versatility, the so-called "Spider" structure has been designed to have the structure shown in Figure 1. It makes possible different pivot connection points in order to always have a coincidence between the center of gravity of the system and the rotational axis of the pivot. This is the first step towards the concept of great versatility in the gondola, because it makes it possible to retain a static equilibrium of the system for each solar panel position. Figure 3 shows the spider structure. It consists of a shell on which four different holes are tooled in positions which the center of gravity may assume. The pivot is fixed in these holes by means of adequate bolts.

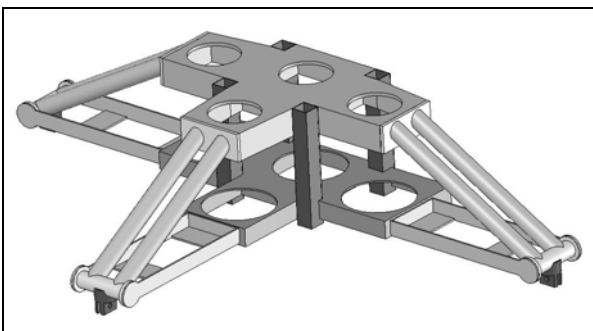

Fig. 3: The spider structure.

The 3D parametric virtual model was built in order to design the "spider" component for predicting the positions of the global center of gravity in each admissible position of the solar panels. In Figure 4, the coordinates of the global center of gravity are shown.

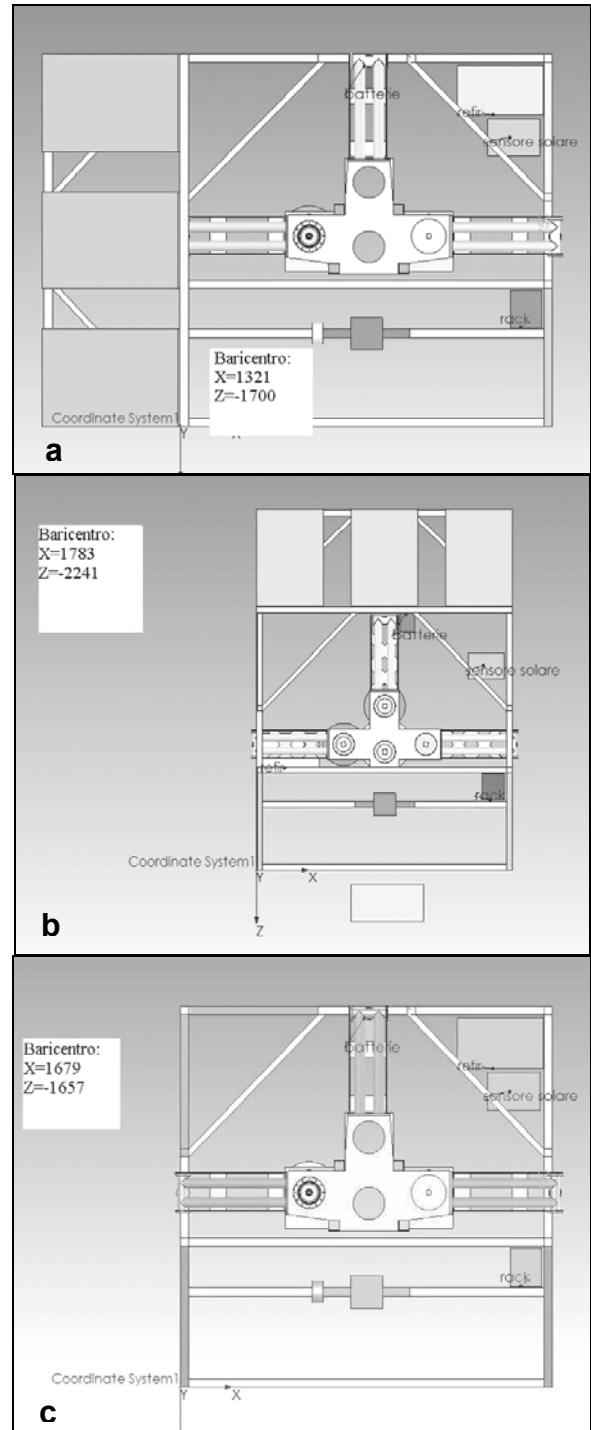

Fig. 4: The virtual model used to track the center of gravity positions in order to design the spider structure. The solar panels are on the left side (a) and on the rear side (b) of the gondola frame. The configuration without the solar panels(c) has been taken into account.

It is worth noting that, for each configuration of the solar panels, a different layout of the components has been adopted in order to reduce the moment of inertia

with respect to the pivot axis, thus preserving all the functional requirements and minimizing the angular response for the azimuth regulation. Virtual prototyping is a very important tool for supporting the designer: thanks to the CAD model, the rapid and efficient testing of several different configurations was made possible.

The stiffness/strength specifications and the dimensions of each structural element were verified using the Finite Element Method (FEM) from the ANSYS v. 8.1 code. The virtual model used to perform the layout analysis was employed to set up the FE model. In order to take into account the dynamic effects generated due to the accelerations under which each mass of the system is subjected, the simulations were performed for two load cases: first, with an applied vertical mass acceleration equal to 10g; then, with an acceleration equal to 5g and with an angle of 45° with respect to the pivot axis. This load case simulated the parachute opening conditions.

Using the FE method, the designers performed this type of analysis for each one of the three solar panels configurations. The results of these simulations demonstrated that the “spider” is the critical member of the system from the point of view of stresses and strains.

At the end of the design process described above, the final version of the gondola frame, as shown in Figure 2, was obtained. The mass characteristics and the overall dimensions are summarized in Table 2.

Table 2: gondola characteristics.

Component	Weight (kg)
Gondola frame	490
Spider structure	210
Useful load	760
Total mass	1460
Overall dimensions (m)	3 X 3 X 3

The maximum inertia moment of the system evaluated by comparison with the pivot axis was equal to 3000 kgm² when the solar panels were mounted on the left or right side of the frame. The overall dimensions of the frame were split up into smaller parts in order to satisfy the criteria of easy transportability. The requirements of the launching system of some well-known bases were also respected.

A second step towards the optimization and power saving concepts was that of reducing the mass of the gondola frame and its moment of inertia while keeping unmodified all the previous features. In the following sections, a new systematic approach for performing this task will be described.

3. IMPROVEMENTS TO THE “GONDOLA”: A SYSTEMATIC APPROACH TO DESIGNING NEW CONCEPTS.

The improvements in the technical solution described in the previous sections, which were based on a reduction in the inertia moment as well as on the minimization of the mass frame, are possible only by adopting a systematic approach to the design problem.

This task can be performed by using in an integrated way: the Problem-Solving techniques that are able to guide the designer towards innovative, creative technical solutions, and topology optimization which is a useful FEM-based tool that supports the translation of functional schemes to a first optimized shape of the structure.

Here as follows, the use of these techniques will be described as applied to the gondola frame design problem.

3.1 Problem-solving techniques.

Starting from the design specifications and the boundary conditions, the first step in the systematic approach consists of performing the functional analysis of the whole frame-experiment instrumentation system. This is an efficient way to characterize useful and/or harmful actions between each component from the point of view of functionality. The result of this phase is a diagram that assigns to each component of the system its own function and it describes, in an explicit way, the harmful/useful actions.

By reducing any possible harmful actions, the designer is guided towards innovative functional schemes that represent a technical solution to the design problem.

The problem-solving techniques applied to the gondola layout design problem suggested a scheme in which the experiments that need azimuth regulation must be divided from the others. This solution makes possible a reduction in the inertia moment with respect to the pivot axis, and increases the azimuth regulation response in terms of angular acceleration.

The reduction in the frame weight can be obtained by a layout of the masses in which the center of gravity of the whole system has a constant position that does not depend on the center of gravity of the solar panels. In this way, the “spider”, which is the critical structural member from the point of view of weight and stresses, may be avoided. This occurs only if the center of gravity of the solar panels in each of their positions coincides with the global center of gravity of the system.

A very innovative functional scheme having the characteristics described above is shown in Figure 5. According to this picture, in this layout the solar panels

and the telescope are mounted on the structure that has a portal shape, while the other components of the experiment are arranged on the upper frame. The symmetry of the layout enabled the center of gravity to maintain a constant position!

The pivot gear box in this scheme connects the portal structure to the upper frame. In this way, only the telescope and the solar panels have regulation of the azimuth. This functional scheme makes possible a reduction in the inertia moment of about 20% with respect to the pivot axis, as compared to the solution described in the previous section.

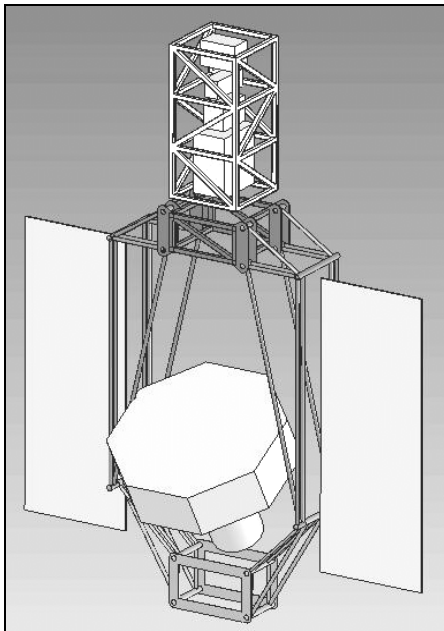

Fig. 5: The innovative functional scheme enables the center of gravity to maintain a constant position.

This solution has a total height of about 6 meters, in accordance with the dimensional requirements of the launch system, but at present it has not been further developed. However, the results obtained are still a valid concept for the design of more innovative and versatile solutions.

3.2 Topology and shape optimization.

Starting from the functional schemes obtained by performing all the above-described analyses, the next step in the design process consists of obtaining a shape for the gondola frame. The optimal shape is one that is able to satisfy the structural specifications in terms of stiffness, strength, and position of the center of gravity. This aspect is a crucial issue in satisfying the static equilibrium of the gondola, because the center of gravity of the frame is assigned by the position of the center of gravity of the entire system.

All these structural requirements can be satisfied only if the shape generation phase is carried out as an

optimization process. A useful tool for supporting the designer in performing this task is the topology optimization method [4].

By means of this method, a first material distribution in term of density can be obtained, starting from an initial volume discretized by finite elements. The specifications guide the optimization process towards the optimal shape of the structure. This first shape will be further developed during the design process, using size and shape optimization techniques in order to achieve the optimal final shape of the structure in just a few iterations.

To perform shape generation using topology optimization, the problem must be set up in terms of the:

1. definition of the initial Design Domain of the structure;
2. definition of the Objective Function to maximize or minimize;
3. definition of the Constraint Functions guiding the optimization process.

The initial Design Domain is a bulk volume of material that has a shape that is able to satisfy the functional requirements of each component constituting the system. In other words, the boundaries defining the initial volume are represented by the functional surfaces of each component. This volume is obtained by means of the 3D CAD model and is discretized by using the finite elements method. Boundary conditions in terms of loads and constraints are applied to this model.

The functions guiding the shape optimization process are directly derived from the structural specifications. For the frame of the gondola, these functions are:

1. Objective Function: Global Stiffness of the structure;
2. Constraint Functions: Mass of the structure and center of gravity position.

At the end of the topology optimization process, the shape having the maximum global stiffness under the specified maximum weight and center of gravity position is obtained.

Some different optimized shapes are already been obtained using this tool: in Figure 6, one of these solutions is shown. According to Figure 6(a), the initial Design Domain is derived by taking into account the functional requirements of the telescope and the solar panels (summarized in section 2). This volume has been discretized using the finite elements method, and all the boundary conditions have been applied to the model shown in Figure 6(b)

The optimization process for maximizing the global stiffness with an upper limit of the final volume equal to 20% of the initial Design Domain and an imposed center of gravity position, given by the system layout, led to the basic optimal shape shown in Figure 6(c).

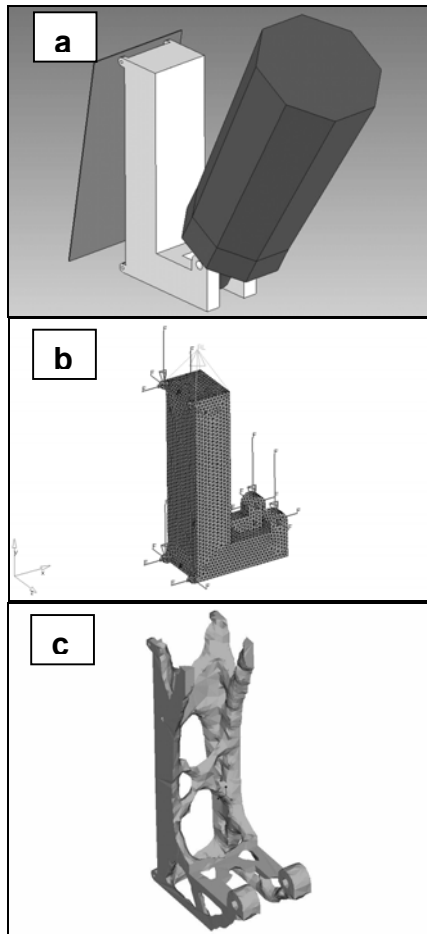

Fig. 6: The optimization process: the Design Domain has been obtained (a) in function of the functional requirements, and (b) the FE model has been set. At the end of the optimization cycle, the shape shown in (c) is obtained.

In Figure 7, the layout of the system is presented with the optimized shape of the gondola frame obtained at the end of the optimization process.

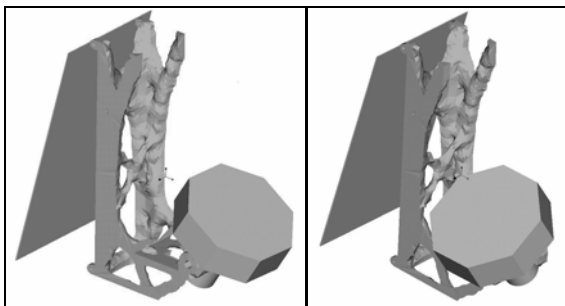

Fig. 7: The initial layout with the optimized frame.

By defining a different objective function to maximize or minimize (the inertia moment, the height or the weight of the structure), several optimal shapes can be obtained. This makes it possible to define “families” of optimized shapes for the frame in function of the requirements and the structural characteristics of each type of experiment.

4. CONCLUSIONS.

The “BarSPort” experiment was presented, and some steps towards to a concept of full versatility for a general- purpose gondola design were described.

The main features of the first version are the possibilities of changing the direction of sky observations by taking advantage of the same platform design in which the CAD software predicts three different positions for the solar panels and a fourth one without solar panels but with traditional lithium batteries. In this way, the freedom to observe different sky targets - as well as the possibility of hosting other small experiments - has been satisfied.

The CAD/CAE tools played a basic role in designing and testing several technical solutions. By using a systematic approach to the design process, the new concepts of the first layout, even though different from those widely employed by other scientific teams, were further developed in order to reduce the weight and the inertia moment of the system with respect to the pivot axis. Some of these solutions were described. The use of topology optimization techniques, in order to generate several optimal shapes for the gondola frame, was described. One of these was presented.

5. ACKNOWLEDGEMENTS.

This work was partially supported by the Italian Space Agency under contract N. I/R/104/02.

REFERENCES.

1. Balloon-Borne Sky polarization Radiometer (BarSPort) Experiment: <http://spOrt.bo.iasf.cnr.it>
2. Boscaleri A., Venturi V., Colzi R. *A time domain computer simulation program as first step of a full digital high precision pointing system for platform in balloon-borne remote sensing*, SPIE Proceedings Infrared Technology XVI, Vol. 1341, 58-65, 1990.
3. Radiation Explorer the Far Infrared (REFIR): <http://refir.ifac.cnr.it/index.html>.
4. Bendsoe M.P., Sigmund O., *Topology Optimization Theory, Methods and Applications*, Springer Verlag ISBN 3-540-42992-1.