

Spring 5-4-2018

The Effectiveness of Code-Switching in Evangelism: The Use of African American Vernacular English by Standard English Speakers

Cameron Joseph Myers
Cedarville University, cjmyers@cedarville.edu

Follow this and additional works at: [http://digitalcommons.cedarville.edu/
linguistics_senior_projects](http://digitalcommons.cedarville.edu/linguistics_senior_projects)

 Part of the [Applied Linguistics Commons](#), and the [Semantics and Pragmatics Commons](#)

Recommended Citation

Myers, Cameron Joseph, "The Effectiveness of Code-Switching in Evangelism: The Use of African American Vernacular English by Standard English Speakers" (2018). *Linguistics Senior Research Projects*. 18.
http://digitalcommons.cedarville.edu/linguistics_senior_projects/18

This Capstone Project is brought to you for free and open access by DigitalCommons@Cedarville, a service of the Centennial Library. It has been accepted for inclusion in Linguistics Senior Research Projects by an authorized administrator of DigitalCommons@Cedarville. For more information, please contact digitalcommons@cedarville.edu.

The Effectiveness of Code-Switching in Evangelism:

The use of African American Vernacular English by Standard English Speakers

Cameron Myers

Cedarville University

Abstract

This paper evaluates the use of code-switching as a linguistic and pragmatic tool to build interpersonal relationships between members of the African American minority group and the Standard English “white majority” for the purpose to evangelize the Christian faith. Using the Shannon-Weaver (Shannon & Weaver, 1999) communication model as a foundation, the research suggests that changing the message is the best way to overcome barriers in interpersonal communication (namely evangelistic communication). The research varies in use of code-switching as a pragmatic tool for this message change. Ariffin (2009), Jørgensen (1998), and Madsen (2004) give positive evidence for code-switching, while Anderson (2007) contrastingly argues that lexical borrowing is more favorable, and Wilder (1984) argues that cultural typicalness is most favorable. This research analyzes code-switching in an inner city teen center by reviewing questionnaires from the out-group volunteers and interviewing a volunteer with dual in-group membership. The original hypothesis states that the use of code-switching has a neutral to positive effect on building credible relationships between the majority out-group and minority in-group and thereby would be an effective evangelistic tool. However, the questionnaires and the interview reveal a neutral to negative effect of code-switching which supports the arguments of Wilder (1984) and Anderson (2007).

Keywords: code-switching, evangelism, African American Vernacular English (AAVE), Shannon-Weaver

The Effectiveness of Code-Switching in Evangelism:

The use of African American Vernacular English by Standard English Speakers

Christian evangelism has historical roots since the ascension of Jesus Christ and the commandment from him to spread his gospel. From the origin of evangelism rises the barriers of intercultural communication, which seems to be understood by Christ and his disciples when he tells them to witness to “Jerusalem, and in all Judea and Samaria, and to the end of the Earth” (Acts 1:8, English Standard Version). If the disciples were to go to the end of the Earth, then they are destined to come in contact with a plethora of cultural differences and communication barriers. The diversity of humanity is no less real today than it was in the early church. Neither is the Christian obligation to evangelize. Yet, the problem remains as to how to evangelize effectively when cultural differences disrupt interpersonal communication. One such area of disruption is in American urban outreach. Often times, a Christian subset of the Standard English “white” majority group, a demographic that is consistently present in the modern evangelical movement, attempts to reach out and evangelize to the urban cities, primarily composed of the AAVE-speaking minority group. The difficulty ensues when the background of relational and cultural differences between these two groups creates a divide between them, and prevents effective ministry. This paper seeks to evaluate code-switching as a pragmatic method for communication, originally proposing from the literature review that code-switching can possibly have a positive effect on communication between the African American Vernacular English (AAVE)-speaking minority and the Standard majority.

Literature Review

One cannot respond to the contrast between man's depravity and God's supremacy and resist the urge to evangelize. Christians have the responsibility to spread the gospel to everyone, because Christ died for everyone. Evangelist Robert Coleman (1964) declares this by saying, "Jesus gave himself to provide a salvation from all sin for all men. In that He died for one, he died for all" (p.18). Thus evangelism as a pursuit, rooted in the apostles and carried on today, is an attempt to reconcile the fallen humanity to their perfect Creator through the willing sacrifice of Jesus Christ. Evangelist Will McRaney (2003) describes this phenomenon as God "yearning to have an eternal relationship with His people" (p.15). God longs for the prodigal son to return, and is desiring all people to come to him. The issue therein develops for the evangelist, as spreading the gospel to the whole world is complicated.

Dr. Charles Kraft (1991) points to differences in areas of culture, educational background, and even dialects as a filter that influences communication at the deepest level. This creates a need for a foundation to be placed to convey the message of the gospel (Coleman 1964), and a construction of "credible relationships" with those to whom one is "attempting to communicate the message of Christ" (McRaney 2003). This research will attempt to tease out the best way to establish this foundation in the context of urban city ministry, using the process of dialect code switching and other pragmatic devices to interpersonally communicate the gospel. In order to begin, however, we need to take apart these concepts from the current corpus of research.

Interpersonal Communication and Pragmatics

Communication can be understood through the Shannon-Weaver model (Shannon & Weaver, 1998). This simplified model of communication is understood in four parts (see figure 1). First is the sender (information source), who originates the information. The content (message) is then sent through a transmitter, which is the medium. Lastly, the message is received by the recipient, called the destination, through a receiver. The receiver is what takes the message and decodes it into meaningful information. In interpersonal communication, the Shannon-Weaver model generally follows that a person (source) sends the message through speech (transmitter) which is received through the ears of another person (receiver) and decoded into meaningful information (destination). While this model has been defended and contested, it can provide in this setting a basic framework on which to build upon.

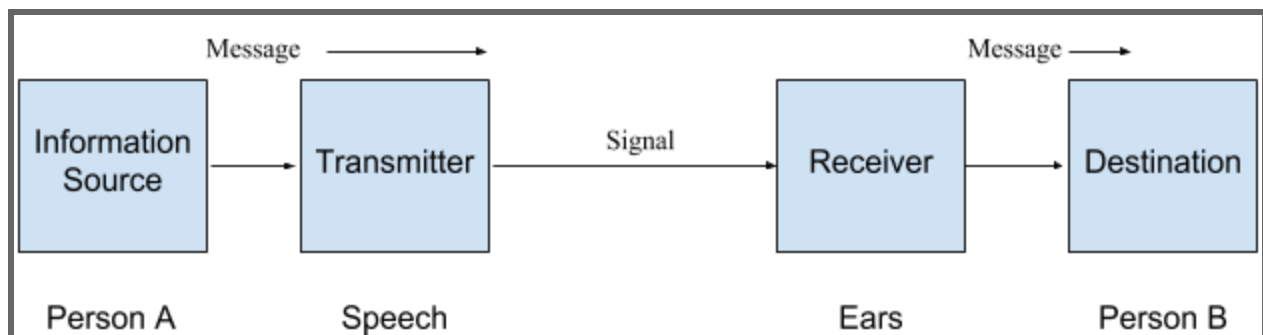

Figure 1

The term “interpersonal communication” is used in its broad sense here to mean “communication that is based on social roles and exchanges that... connect in ways to emphasize them” (Stewart, 2009, p. 32). John Stewart himself (2009) disagrees with this view, narrowing

the definition to “contacting each other as persons” or “unique individuals” (p. 32). His emphasis here is on the concept that people communicate on a personal rather than a cultural or social level. Michael Haugh (2013) refutes this notion and argues that Stewart’s concept would only function in the “North American understanding of personhood as an ‘independent, monadic self,’” (Haugh, p. 3) and not the worldly sense of interdependent identity orientation. There is no disconnect in communication between the person and his culture. Norms and practices from the culture are seen to “form the background on which the participants interact” (Ogoanah & Kpolugbo, p.147). Many aspects of the interpersonal communication process are “invariably motivated by cultural misunderstandings” (Ogoanah, Kpolugbo, p. 133). The concept of a cultural background acting as a filter for communication echoes Kraft’s (1997) view of communication theory discussed earlier. The cultural emphasis on communication connects the success or failure of evangelism to the reception of not only the gospel, but also the cultural interpretation of that gospel. In the urban city context, the African American minority will, because of this, interpret the gospel through the cultural lense of the evangelist. If there are differences between the backgrounds of the evangelist and the minority, then the gospel could be rejected.

Therefore, the evangelist has to seek out a pragmatic approach to his/her witness. Pragmatics here is defined as the “cognitive, social, and cultural science of language and communication” (Verschueren & Ostman, 2009, p.1). I believe that Verschueren and Ostman’s definition of pragmatics is most accurate for the evangelistic context, because it accounts for the cultural lense of communication, and forefronts the linguistic nature of the communicative science. Locher and Graham (2010) comment that Verschueren’s definition “allows us to

examine the complexity of language use from a rich array of perspectives” (p.1). Pragmatics is therefore a linguistic tool that can be utilized in order to get past the cultural barriers, but what exactly are those barriers in an urban context, and how can evangelists use pragmatics to help?

Barriers to intercultural communication

In sociolinguistic and pragmatic research such as this, it is important to determine the linguistic attitudes of the two groups involved. Generally, the communication blocks in evangelism are not present between members of the same cultural group, as there would be only negligible background differences. Members of the urban community are not opposed to the presentation of the gospel from a member of their own community. It is when a member of a different community comes to minister to them that we see problems arise. Unfortunately, this is often the case. Members of the church, often labeled as the “white church,” are ineffective in communicating the message of the gospel to the urban community. This is because, as one member of the minority speech community writes, the minority “feels that they have to adjust their code to fit the majority’s” and that “it feels as if many whites refuse to imagine what it feels like to be the minority or to love the minority” (Adams 2015, p.1). This exemplifies the concept known as the “minimal group paradigm” (MGP), originally proposed by Henri Tajfel which suggests the idea that “in the absence of realistic conflicts of interests... people would tend to favor their own group over other groups” (p. 85). Otten goes on to claim that the MGP has expanded from the study of variable to “a whole range of other interpersonal, intragroup, and intergroup phenomena” (p.88).

Further, ingroup favoritism is “a relational phenomenon, shaped by interdependencies between groups and individuals” (Durrheim K, Quayle M, Tredoux CG, Titlestad K & Tooke L,

2016, p.1). These researchers studied intergroup dynamics in the context of the MGP and concluded that “participants tended to favor those who had favored them in the past or were likely to favor them in the future” (p. 21). This ingroup favoritism is contingent upon the history of interaction of two or more groups. If there has been no interaction, then the MGP does not apply, which is why an urban community member can evangelize to another with more ease than an outsider. Unfortunately, it is often the case that the outsiders (usually the “white churches”) are the ones trying to evangelize and reach the lost in an urban setting. In this case, the minority group being communicated to takes into account the past interactions between them and the majority “white church.” Among the African American population, there is a consistent attitude that representing more of a “white American” look or feel will lead to more success (Monk 2003). There are three responses to this skin tone stratification and the MGP. The first is to attempt to change the recipient (the destination in the Shannon-Weaver model). This is to assume that the African American minority should just adapt and adopt the ways of their white majority, chiefly their Standard English. The second is to change the sender of the message to minimize the differences. This is to change the sender’s identity itself. The third option is to change message. This is to recognize and minimize the differences in communication between Standard English and the minority dialect, in this case African American Vernacular English, or AAVE.

Destination: Minority Adaptation

It would be a mistake to believe that forcing the minority to assume the Standard is an effective means of interpersonal communication or evangelism. The minority group has suffered generations of discrimination and abuse from the majority. The causation of the “white

American” as being more powerful or successful does not stem from any innate quality or distinguishable advantage, but rather from the generational mistreatment and discrimination. Though America today is progressing towards equality for the minority groups, there still remains a deep root of difference between the groups. In defense of the minority English culture, Alice Filmer (2003) argues that the minority dialect, what she calls an “acoustic identity” is so rooted in a complex historical sociology that it “ultimately conflates the use of Standard English with Whiteness and Western Imperialism” (p. 761). Because of this, she claims, it is a matter of unethical “linguistic ethnocentrism” to believe that Standard English is neutral and culturally unifying.

It is therefore foolish to believe that one can effectively communicate the gospel by ignoring the culture and society of their audience. Evangelists cannot expect the lost to look, act, or speak like they do themselves. Many times, there have been efforts taken by the church to transform their gospel recipient into their own image, yet the only circumstances by which the gospel has been “effectively” communicated is within the context of force, such as in the Crusades, or the anglicization of the Native Americans. This method is therefore not viable in today's context.

Sender: Identity Shift

Interpersonal communication should act as bridge building, creating meaningful connections and relationships between two groups. So, if adapting the minority into the majority's image is ineffective, one must consider the alternative. The evangelist must look at the differences between themselves and the minority group and attempt to minimize the differences that, as Kraft (1991) has mentioned, “strongly influence communication at the deepest levels” (p.

100). It is impossible and unhelpful, however, to completely “be the minority” as Isaac Adams (2015) suggests. Research from David Wilder (1984) suggests that “the effectiveness of favorable contact with an out-group member on evaluations of the out-group depends on how typical the person is of his/her group” (p184). This is to say that someone can create a more favorable connection if they represent the perception of who the in-group thinks they are. Wilder goes on to assert that “changes in attitudes toward an out-group may occur without changes in stereotypes of the group” (p 184). This falls in line with McRaney’s (2003) evangelistic view, which claims that “As the world becomes more anti-Christ, it is imperative that Christ followers possess different values and behaviors from those without Christ” (p.68).

Message: Linguistic Shift

The last option in minimizing the differences is to manipulate the language itself. This is where pragmatics is crucial. Utilizing language as cognitive, social, and cultural science (Verschueren & Ostman, 2009), the evangelist will have the most success if he/she approaches the topic from a linguistic standpoint rather than through identity.

The general approach to the linguistic shift is to code switch. As a hybrid between communication and language, code switching is “a tool to achieve ... the negotiation between language use and the communicative intents of the speakers” (Ariffin & Rafik-Galea, 2009, p. 15). Though commonly perceived as exclusive to languages, a substantial amount of research has been done with the extension of code switching to both AAVE (Wheeler, 2008, Williams-Farrier, 2016) and the Appalachian dialect (Brashiers, 2014). It can be understood that the principles that apply to code switching between languages can also be applied to between dialects.

The effectiveness of code-switching in interpersonal communication is debated. Wilder's "typicalness" could have influence in language use as well, where there could be an extent to which switching codes influences the perception of the speaker's identity, producing a less favorable outcome. Jørgensen (1998), however, found code switching to be a useful tool to "express solidarity, or to rebel, or to exclude a particular conversant" (Jørgensen, 239). If done in the correct way, it is possible to express solidarity with a group to which the speaker does not belong. In continuation of Jørgensen's research, Madsen (2004) claims that linguistic variation is a "means of negotiating power relationships and identities" (Madsen, 2004). By application of Jørgensen and Madsen, an evangelist could manipulate language in order to express solidarity and establish a relationship with the minority group. Once the relationship is established, according to Coleman (1964), the evangelist can "build an effective and continuing evangelistic ministry to the multitudes" (p. 33). In theory then, it is plausible to conclude from Jørgensen and Madsen that code-switching is an effective pragmatic tool for evangelistic communication.

Anderson and Toribio (2007), however, make a different claim. Studying Spanish English bilinguals, they found that bilingual speakers evaluate single-noun insertions more positively than code-switching" (p. 217) Countering Madsen and Jørgensen, Anderson and Toribio infer that bilinguals prefer lexical borrowing to code-switching. In the evangelist's context, this would mean that the minority group would prefer the evangelist use their lexicon, but not their phonology or grammar. This could align with Wilder's "typicalness" concept, where using the whole dialect is seen as "out of place" for an outsider, but certain lexical borrowings are seen as appropriate, or expected.

In my research, I intend to contextualize the theories of Anderson, Toribio, Wilder, Jørgensen, and Madsen, in order to determine which approach to pragmatics will produce the most favorable results in establishing the relational framework between AAVE speakers and Standard English speakers. Based on the research, it seems most plausible that code-switching from Standard English to AAVE by out-group members will have a neutral to positive effect on evangelistic communication, meaning that the code-switching will go unnoticed, or be seen as a tool for solidarity. Lexical borrowing is therefore useful, but insufficient in completely connecting to the minority in-group.

Method

Participants

Participants were 7 volunteers working at a Christian teen center located in an urban neighborhood. The participants voluntarily completed a questionnaire without desired compensation. Their ages ranged from 18-24; all are university students or alumni, and all except one is caucasian. The participants were chosen because they are out-group members of the Standard English-speaking majority attempting to evangelize to the in-group urban minority. Their out-group status was represented by their university status and their own admission. Their evangelistic focus was represented in both the nature of the center they are volunteering for and their direct expression of intent to evangelize. Because of the qualitative evaluation of the minority majority interactions, this study was restricted to those actively witnessing to an urban population, specifically the teen center in focus. Participation in this study was on a voluntary basis. No compensation was desired or given; all questionnaires were given freely.

There was also one volunteer for an interview. He also is a volunteer for the Christian teen center, but also attended the center as a child. Converted to Christianity as a young adult, this 24 year old man is a member of both the minority in-group (because of his childhood) and the majority out-group (because of Christian relationships created after conversion).. He was chosen for the interview because of his unique dual membership of both sociolinguistic groups, his experience with out-group interactions as a teen, and his evangelistic intent. Participation in this study was on a voluntary basis. No compensation was desired or given.

Materials

The seven majority-member participants were given a qualitative survey with four questions and a space for additional information. Participants were able to give as much or as little detail as they desired. Three of the four questions were completely open-ended. As such, the goal of these questions were to elicit linguistic attitudes towards AAVE and expert opinion of evangelistic effectiveness. The participants are considered experts on this topic because they actively evangelize to urban youth. They have substantial insight to the effectiveness of their own speech towards the in-group. See Appendix A for survey questions.

The remaining question involves the participants responding to a list of Ebonic lexical categories by labeling each as appropriate or inappropriate for out-group members to use with in-group members. The words or phrases can be placed in three separate categories: culturally connected words/phrases , non-culturally connected words/phrases, and grammatical/morphological phrases.

The interview contained the same lexical list as the last question of the questionnaire. There were also three additional open-ended questions and room for additional information. The

open-ended questions were used to elicit the participant's linguistic attitude towards non-native use of AAVE as an expert opinion of relational effectiveness. The participant is considered an expert on this topic because of his dual membership in the in-group and out-group.

Procedure

All questionnaire participants were asked to express their viewpoints with as much or as little detail regarding three specific areas: the need for evangelism, the appropriateness of AAVE by non-native members, and the appropriateness of lexical borrowing by non-native members. They were also asked for any additional information on the topic of the study. Participants wrote or types their expert opinions in a paragraph or less.

The interview was given in a separate room without any other participants. There was no review of the questionnaires before the time of the interview, and influence from them on the interview itself. The participant spoke freely about his viewpoints, and contrasted his opinion as a teen to his opinion as a volunteer. He was able but not required to give additional information or reasoning as to why certain lexical categories were appropriate or inappropriate, as well as in what context. Lastly, the participant gave advice for out-group members on the sociolinguistic methods of communication.

Results

Questionnaire

All survey responses indicated a common theme. The first question asked for the participants' perceptions of the need to evangelize to inner city populations. The results were not surprising. Of the seven volunteers, six of them indicated in their responses that there is a "huge need" to evangelize to this group, all seven at least indicating that one should evangelize to the

group. The one differing opinion here is a current volunteer who writes that “It (inner-city evangelism) is a good thing and people should do it. I just don’t think it sticks.” He goes on to mention that past friends will tend to bring them back to same old habits. This participant’s response does not so much deny the need for evangelism, but rather suggests a deeper issue not dealt with in this research: the effect of negative influences on life-change. For this participant, it is pertinent for many inner city members to change their environment following a decision to follow Christ.

The first question of the survey received the only conclusive answer. The second open-ended question asked how the use of AAVE by a Standard English speaker in a urban environment is effective or ineffective for the purposes of evangelism. Interestingly, none of the participants reasoned that code-switching is completely ineffective for evangelism. Two of the seven indicated that using AAVE is effective for evangelism without mention of limitations. Both participants mentioned that minority group members could relate to code-switched speech better than if it was Standard English. The other five also indicated that code-switching is effective, but within certain parameters. One participant actually suggested lexical borrowing as “lingo interwoven throughout the discourse” as a way to “increase the speaker’s credibility.” Two other participants warned against “forcing it.” They claimed that it is destructive to “force yourself into their culture or way of speaking.” Similar responses mentioned the maintenance of one’s own identity, as well as the avoidance of culturally connected speech.

For the more quantitative section of the questionnaire, the participants responded to a list of AAVE words and phrases, labelling them as appropriate or inappropriate for out-group members to use in conversation. The results can be seen in Figure 2 below.

Word/Phrase	Phrasal Category	Individual Acceptance Rate	Category Acceptance Rate
“You tryin’ to”	Non-culturally connected	100% (7/7)	90.5%
“Throwing hands”	Non-culturally connected	85.7% (6/7)	90.5%
“Cuz”	Culturally connected	71.4% (5/7)	28.6%
“Fuz”	Culturally connected	14.3% (1/7)	28.6%
The N word	Culturally connected	0% (0/7)	28.6%
“Get up through”	Non-culturally connected	85.7% (6/7)	90.5%
“Forcin’ it”	Non-culturally connected	100% (7/7)	90.5%
Double Negatives (“Ain’t no reason”)	Grammatical/Morphological	71.4% (5/7)	85.7%
“Peanut Head”	Culturally connected	28.6% (2/7)	28.6%
“Clean”	Non-culturally connected	100% (7/7)	90.5%
“Smack”	Non-culturally connected	71.4% (5/7)	90.5%
[-in] instead of [-ing]	Grammatical/Morphological	100% (7/7)	85.7%

Figure 2

As apparent from Figure 2, the acceptance rate of the individual words/phrases is similar to the category acceptance rate. The only outlier of these phrases was “cuz” which shows a significantly higher acceptance rate than the other culturally connected phrases. This can possibly be explained by the interview results as a misunderstanding of the word’s meaning. The general trend from the table is that using words or phrases with culturally connected meaning seems to have a significantly negative effect, whereas words or phrases that are not culturally connected are overwhelmingly positive. This is in line with the participants who said that AAVE should be used in a limited manner for members of the out-group.

An important point to note from this is that most participants indicated the importance of the relationship with regards to evangelism and code-switching. “Limiting forcefulness,” “building relationships,” and “being yourself” were critical themes throughout all of the participants’ responses.

Interview

The interview was divided into the participant’s viewpoint as a teen member of the in-group, and a dual adult member of both the in-group and out-group. First, the participant was asked about his perception of Standard English speakers, or the members of the outgroup. He responded that as a teen, he saw them negatively, stating that they were “not from around here” and therefore “not going to understand me.” He mentioned the fact that as he grew older, that prejudice began to fade, to where he currently has a neutral view towards them. When asked about the out-group’s use of AAVE in an urban environment, he mentioned that it was offensive when the terms “do not fit” or when it seemed like the speakers tried to “change who they are.” Interestingly, he mentioned that the relationship he had with the out-group member greatly determined his viewpoint on their code-switching. He mentioned one particular out-group friend of his who, as they grew in their friendship, was allowed to use more and more AAVE. There seemed to be a progressively positive view of in-group speech by the out-group member as the he built a credible relationship, while maintaining the out-group identity.

The interview participant's responses to AAVE words/phrases can be seen in Figure 3.

Word/Phrase	Phrasal Category	Individual Response	Category Acceptance Rate	Agreed with Questionnaire?
"You tryin' to"	Non-culturally connected	Positive	50%	Yes
"Throwing hands"	Non-culturally connected	Negative	50%	No
"Cuz"	Culturally connected	Negative	33%	No
"Fuz"	Culturally connected	Positive (unused)	33%	No
The N word	Culturally connected	Negative	33%	Yes
"Get up through"	Non-culturally connected	Negative	50%	No
"Forcin' it"	Non-culturally connected	Positive	50%	Yes
Double Negatives ("Ain't no reason")	Grammatical/Morphological	Positive	100%	Yes
"Peanut Head"	Culturally connected	Unused	33%	No
"Clean"	Non-culturally connected	Positive	50%	Yes
"Smack"	Non-culturally connected	Negative	50%	No
[-in] instead of [-ing]	Grammatical/Morphological	Positive	100%	Yes

Figure3

It should be noted that the participant in the interview agreed with the other participants on only half of the words/phrases. He suggested that the lexical borrowings that were appropriate were only so because they would go relatively unnoticed. This is particularly the case for the grammatical/morphological category, of which he states he was hardly aware that he participated in. These results suggest a neutral to negative response to lexical borrowing.

Along with the questionnaire participants, the interviewee suggests that the best rule of thumb is to be one's self. He then connects the appropriateness of code-switching to its sound,

indicating that using AAVE is only appropriate for out-group members when it is “normal sounding.” Otherwise, the code-switcher will seem to be “trying too hard” and “inconsistent.” There is also a largely stressed importance of the relationship. He mentions specifically that a “handshake goes a long way.” In fact, there is more notice to one’s out-group nature when they do not shake hands in the correct way. It is almost as if this handshake represents to the minority group that one is able to be in the in-group. Get this part wrong, and the potential for interpersonal communication all but disappears.

Discussion

Based on the literature, it was hypothesized that code-switching from Standard English to AAVE by out-group members will have a neutral to positive effect on evangelistic communication. This assertion seemed legitimate because of Jørgensen (1998) and Madsen’s (2004) research on code-switching. However, the qualitative research in this study strongly affirms Wilder’s position (Wilder, 1984) that favorable communication comes from representing your group.

Instead of a neutral to positive reaction to code-switching, the interview indicated that there was a neutral to negative reaction. The neutral portion here is for the lexical borrowings in which the in-group listener simply does not notice that code-switching is taking place. This does pose an issue to the results of the questionnaires, which suggest code-switching in the non-cultural context was an effective tool to make content more relevant or relatable. These differing interpretations could be reconciled by noting that the questionnaires were given to out-group members. This would mean that the responses from the questionnaires represent the perception of the code-switching as an out-group member. The interview, in contrast, represents

the perception of the code-switching as an in-group member. The contrast here creates distance between perceptions of what is relevant and acceptable, but should not be interpreted as contradictory. For an out-group member, the use of code-switching is an attempt to stay relevant. Most of the responses indicated that they had no intention of using AAVE to identify one's self as an in-group member. In fact, they consistently suggested to maintain their own identities. Therefore the questionnaire responses stay in line with Wilder's theory.

Another aspect drawn from the interview is that there is an almost immediate identification of a person as an in-group or out-group member. Beyond the racial dimension that is often perceived as representative ("whiteness" as majority), the handshake mentioned seems to be a subconscious test of group membership. Once the minority group recognizes the person as a member of the out-group through the handshake or some other factor, code-switching can be conceptualized as a breach on their identity. A recognized out-group member using language that represents an in-group could therefore be offensive because it dissonates with their preconceived notion of what the out-group member should sound like. This could reiterate the subconscious statements such as "they do not understand me" or "who do they think they are." This phenomenon could explain why code-switching in the eyes of the interviewed participant is more offensive when it is when it "sounds abnormal," or why the culturally connected lexical categories are seen as significantly less appropriate among both the in-group and out-group participants.

Therefore it is appropriate from the research to accept Wilder's position that contact is most favorable in cases where the interlocutor most typically represents his in/out-group. The

questionnaires and interview indicated that a relational approach in which one maintains their own identity will cause the most positive responses.

Limitations

As qualitative research, this study is limited to the viewpoints of a limited number of perceptions. The research was designed to contribute to the field as a case study of a particular teen center, so it is possible that other urban ministries or evangelism could be perceived differently. Also, the case study is specifically centered around youth. There is the possibility that older generations would respond differently to this type of code-switching. Lastly, given the scope of this research and the availability of resources, the interview was seen as a representation of in-group linguistic attitudes, and the questionnaires as a representation of out-group linguistic attitudes. There is a possibility of variance among other members and therefore is non-exhaustive.

Conclusion

Though non-exhaustive in nature, this research makes substantial assertions for evangelistic practices as well as for code-switching. In the realm of evangelism, there can be a new conception to the concept of Paul's verse to the Corinthians "I have become all things to all people, that by all means I might save some." (1 Corinthians 9:22b, English Standard Version) Upon the assertion that code-switching is an effective pragmatic tool to express solidarity and build credible relationships, one could assume this verse to mean that Paul learned to speak the way of all people, so to evangelize effectively. With this research in hand, the interpretation slightly shifts to be understood as Paul maintaining his true identity, but relating to all people in a way that respects their culture. The Christian evangelist has a need to present the gospel to

differing cultures, yet it may not be in the best interest of the Christian to do so by learning to speak dialects. The best way to approach evangelism is to meet them where they are, as you are.

Assertions made about code-switching are far less interpretative. This study found that code-switching was ineffective as a pragmatic tool for interpersonal communication. Lexical borrowing was determined to be more favorable than code-switching, in accordance with Anderson's study (2007), however there were still substantial restrictions against the use of culturally connected words/phrases. Ultimately, the majority group should not use code-switching to try to identify with the minority group, but should maintain their own identity, and incorporate code-switching naturally as the relationship develops. Therefore, one will find the best possible interactions when the relationship becomes the ultimate priority.

References

- Adams, I. (2015). Why White Churches Are Hard for Black People. Retrieved February 19, 2018, from <https://www.9marks.org/article/why-white-churches-are-hard-for-black-people/>
- Anderson, T. K., & Toribio, A. J. (2007). Attitudes towards lexical borrowing and intra-sentential code-switching among Spanish-English bilinguals. *Spanish in Context*, 4(2), 217-240. doi:10.1075/sic.4.2.05and
- Ariffin, K., & Rafik-Galea, S. (2009). Code-switching as a Communication Device in Conversation. *Language & Society*. 5 (9)
- Brashears, K. (2014). Examining Teacher Perceptions of the Appalachian Dialect in One Rural Appalachian Elementary School. *Rural Educator*, 35(2), 1-10.
- Coleman, R (1964). *The master plan of evangelism*. Grand Rapids, MI: Spire.
- Durrheim K, Quayle M, Tredoux CG, Titlestad K & Tooke L (2016). Investigating the Evolution of Ingroup Favoritism Using a Minimal Group Interaction Paradigm: The Effects of Inter and Intragroup Interdependence. *PLoS ONE*, 11 (11): e0165974. doi:10.1371/journal.Pone.0165974
- Filmer, A. A. (2007). Bilingual Belonging and the Whiteness of (Standard) English(es). *Qualitative Inquiry*, 13(6), 747-765. doi:10.1177/1077800407304459

Haugh, M., Kádár, D. Z., & Mills, S. (2013). Interpersonal pragmatics: Issues and debates.

Journal of Pragmatics, 58, 1-11. doi:10.1016/j.pragma.2013.09.009

Jørgensen, J. N. (1998). Children's Acquisition of Code-Switching for Power Wielding.

Code-Switching in Conversation: Language, Interaction and Identity., 237-258.

Kraft, C. H. (1997). Communication theory for Christian witness. Maryknoll, NY: Orbis Books.

Locher, M. A., & Graham, S. L. (2010). Introduction to interpersonal pragmatics. *Interpersonal*

Pragmatics. doi:10.1515/9783110214338.0.1

Madsen, L. M. (2004). Linguistic Power Wielding and Manipulation Strategies in Group

Conversations Between Turkish-Danish Children. *Nordlyd*, 31(5). doi:10.7557/12.38

McRaney, W. (2003). *The art of personal evangelism*. Nashville, TN.: Broadman & Holman.

Monk, E. (2003) Skin Tone Stratification among Black Americans, 2001-2003, *Social Forces*

Ogoanah, F. N., & Kpolugbo, S. N. (2017). 'I just said It, I didn't mean anything:' Culture and

Pragmatic Inference in Interpersonal Communication. *Legon Journal Of The Humanities*,

28(2), 131-150. doi:10.4314/ljh.v28i2.6

Otten, S. (2016). *The Minimal Group Paradigm and its maximal impact in research on social*

categorization. Elsevier.

Sebba, M., & Wootton, A. (1998). We, they and identity: Sequential versus identity-related

explanation in codeswitching. In P. Auer (Ed.), *Codeswitching in conversation*

(pp.262–289). London: Routledge.

Shannon, C. E., & Weaver, W. (1999). The mathematical theory of communication. Urbana:

University of Illinois Press.

Stewart, John, 2009. Communication and interpersonal communication. In: Stewart, J. (ed.), *Build Bridges, Not Walls. A Book about Interpersonal Communication* (10th edn).

McGraw-Hill, Boston, MA, pp. 15-3

Verschueren, J., & Ostman, J. (2009). Key Notions for Pragmatics. *Handbook of Pragmatics Highlights*. doi:10.1075/hoph.1

Wheeler, R. S. (2008). Becoming Adept at Code - Switching. *Educational Leadership*, 65(7), 54.

Wilder, D.A. (1984) Intergroup Contact: The Typical Member and the Exception to the Rule. *Journal of Experimental Social Psychology* Academic Press Inc. 177-194

Williams-Farrier, B. J. (2016). Signifying, Narrativizing, and Repetition: Radical Approaches to Theorizing African American Language. *Meridians*, 15(1), 218.

doi:10.2979/meridians.15.1.12

Appendix A

Participant Questionnaire

Participant Name: _____

Date: _____

You are being asked to take part in a research study of how code-switching can be effective or ineffective in evangelism. We are asking you to take part because you either: 1) Are able to speak two dialects of English and participate in multiple dialect settings, and/or 2) Have expressed desire to evangelize the gospel of Jesus Christ. The purpose of this study is to learn what code-switching is effective or ineffective when ministering or evangelizing. You must be a member of multiple speech groups or an expert in a relevant field to participate in this study.

We remind you that the study is completely voluntary, and that results are confidential and will be reported anonymously.

- 1) What is your perception of the need to evangelize to inner city populations.?
- 2) In what ways is the use of AAVE by a standard English speaker in an urban/non-urban environment effective or ineffective for the purposes of evangelism?
- 3) Below are a sample of some Ebonic speech. Which of the following would be appropriate/inappropriate for outgroup members to use in conversation with non-ebonic speakers? Ebonic speakers?

<ul style="list-style-type: none"> — “You tryin to...” — “Throwing hands” — “Cuz” (to suggest a familiar relationship) — “Fuz”(to suggest a familiar relationship) — The N word — “Get up through” (to suggest leaving) — “Forcin’ it” (to suggest someone is trying too hard, or being bossy) 	<ul style="list-style-type: none"> — Double Negatives (Ain’t no reason”) — “Peanut-head” (term of insult) — “Clean” (to suggest something is cool or nice looking) — “Smack” (to suggest something tastes good) — “-in” instead of “-ing” (tryin’ vs trying)
---	---

4) Should non-urban individuals use AAVE to evangelize to ebonic speakers? If so, is there a limit to what categories of speech can or cannot be used?

5) Is there any other information that could be helpful in this research, including, but not limited to: Additional words or phrases in our ebonic phrase list, alternative factors in the effectiveness of evangelism, use of ebonic speech, and/or ebonic ingroup membership?

Appendix B

Interview

Interviewer: _____

Interviewee: _____

Date: _____

You are being asked to take part in a research study of how code-switching can be effective or ineffective in evangelism. We are asking you to take part because you either: 1) Are able to speak two dialects of English and participate in multiple dialect settings, and/or 2) Have expressed desire to evangelize the gospel of Jesus Christ. The purpose of this study is to learn what code-switching is effective or ineffective when ministering or evangelizing. You must be a member of multiple speech groups or an expert in a relevant field to participate in this study.

We remind you that the study is completely voluntary, and that results are confidential and will be reported anonymously.

- 1) What is your perception of speakers of Standard English, those who do not fall under the category of “urban” or speakers of “AAVE”?

- 2) What is your attitude towards these speakers’ usage of AAVE in an urban/nonurban environment?

- 3) Below are a sample of some Ebonic speech. What would be appropriate/inappropriate for outgroup members to use in conversation with non-ebonic speakers? Ebonic speakers?

- “You tryin to...”	- Double Negatives (Ain’t no reason”)
- “Throwing hands”	- “Peanut-head”
- “Cuz”	- “Clean”
- “Fuz”	- “Smack”
- The N word	- “-in” instead of “-ing” (tryin’ vs trying)
- “Get up through”	
- “Forcin it”	

- 4) Should members of the Outgroup use AAVE to evangelize to ebonic speakers? If so, is there a limit to what categories of speech can or cannot be used?

- 5) Is there any other information that could be helpful in this research, including, but not limited to: Additional words or phrases in our ebonic phrase list, alternative factors in the effectiveness of evangelism, use of ebonic speech, and/or ebonic ingroup membership?