

Association for Information Systems

**AIS Electronic Library (AISeL)**

---

ICEB 2003 Proceedings

International Conference on Electronic Business  
(ICEB)

---

Winter 12-9-2003

## **Web Services for forward integration in international tourism supply chains: A case study of tourism in Thailand**

Chia-Hui Huang

Han-Ying Kao

Han-Lin Li

Follow this and additional works at: <https://aisel.aisnet.org/iceb2003>

---

This material is brought to you by the International Conference on Electronic Business (ICEB) at AIS Electronic Library (AISeL). It has been accepted for inclusion in ICEB 2003 Proceedings by an authorized administrator of AIS Electronic Library (AISeL). For more information, please contact [elibrary@aisnet.org](mailto:elibrary@aisnet.org).

# Web Services for forward integration in international tourism supply chains: A case study of tourism in Thailand

Chia-Hui Huang (leohkkimo@yahoo.com.tw)

Han-Ying Kao (teresak\_hk@yahoo.com.tw) \*

Han-Lin Li (hlli@cc.nctu.edu.tw)

Institute of Information Management

National Chiao Tung University

1001 Ta-Hsueh Road, Hsinchu, 300, Taiwan, R.O.C.

\*Tel.: +886-3-5712121 ext. 57430; Fax: +886-3-5723792

## Abstract

International tourism is a highly competitive and information-intensive industry. Customers need volumes of information for decision aids. Moreover, the decision-making processes are quite sensitive to the variables of personal preferences, the tourist industrial ecosystem, the legal regulations and political environments of destinations, the regional or global economic situations, the natural matters, and so on. Hence, the owners of tourism are motivated to upgrade the competitiveness of their businesses with information technologies. This paper intends to design the architecture of Web Services in international tourism, which can contribute to the forward integration in international tourism supply chains. First, the authors conduct an in-depth case study of a regional tour operator in Thailand. In the case study, we examine the strength, weakness, challenges, visions, and strategic approaches of international tourism, and their relationships with the information systems in the tourist business. Then, this paper designs the architecture of Web Services in international tourism. The architecture is expected to improve the information transparency through the global tourism supply chain, construct business-to-business collaboration mechanism, provide efficient and effective information to tourists, and consequently contribute to forward integration in international tourism supply chains.

*Keywords:* international tourism, Web Services, Business-to-Business collaboration, forward integration, case study.

## 1. Introduction

International tourism is a highly competitive and information-intensive industry. Customers need volumes of information for decision aids. Moreover, the decision-making processes are quite sensitive to the variables of personal preferences, the degree of competition inside the tourist industry, the legal regulations and political environments of destinations, the regional or global economic situations, the natural matters such as SARS, and so on. Hence, the owners of tourism are motivated to upgrade the competitiveness of their

businesses with information technologies.

The business owner's expectations toward information technologies are reflected on several aspects [1]. To compete with the new entrants, IT is expected to raise entry barriers, such as switching costs, product differentiations, and access to distribution channels. For the customer side, IT is expected to lift customers' selection, switching costs, differentiation, entry barriers, and the competence in forward integration. For the supplier side, businesses expect to increase their selection and competence in backward integration. To contend with the traditional intra-industry rivals, IT is expected to improve the cost-effectiveness, market access, service quality, differentiation in product, and finally the firm itself. IT is also supposed to generate new opportunities and competitive advantages throughout the value chain [2, 3]. The expected contributions of information technologies mentioned above apply to the international tourist industry as well, especially in companion with the Internet and communication technologies. Hence the authors are motivated to conduct a research of the competitive situation and design the architecture of Web Services in international tourism, which can contribute to the forward integration in international tourism supply chains.

In the remaining part of this paper, the authors first analyze an international tour operator in Thailand in section two. The tour operator receives inbound tourists mainly from Hong Kong and Taiwan. In section three, this study summarizes the strengths, weaknesses, challenges, visions, and strategies of information technologies to improve competitiveness in the international tourism. We extract a set of propositions from the case study with managerial implications and insights. In the fourth section, this study presents the architecture of web service for business-to-business collaboration to satisfy the information needs and even the forward integration in an international tourist company. The discussions and concluding comments will be given in the final section.

## 2. Case study: a regional tour operator in Thailand

Company M was founded in Bangkok, Thailand in August 1996. As a tour operator in the international

tourism supply chains, it provides packages of tourism-related services for the customers, including some combination of accommodation, transportation, restaurants and attraction visits [4]. Based on Gee, Makens & Choy [5], the distribution system of travel sales can be classified into four types: one-stage, two-stage, three-stage, and four-stage systems. (See Fig. 1). As shown in Fig. 1, a tour operator like Company M runs its business in the two-stage, three-stage, and four-stage systems. So Company M's direct customers may be the travel agents, tour wholesalers, and individual or group tourists. Most of its tourists travel from Hong Kong and Taiwan. As one of the top three tour operators in the same target markets, it received approximately thirty thousands tourists from Taiwan and fifteen thousands tourists from Hong Kong in 2002. Company M provides various services for various purposes of inbound tourists to Thailand, including sightseeing, business trips, educational communications or interchanges, and supporting some large special projects, such as Asia games in 2000.

As some businesses in the highly competitive international markets, the company has undergone many challenges as well as opportunities since its foundation, yet still erects in tourism and keeps growing continually from a small company toward a medium-sized enterprise. Now there are 15 staffs working at their newly decorated home-like office during the business hours. Outside the humane office, around 40 to 60 professional tour guides travel all over the country with the tourists and provide the first line services.

The attraction of traveling Thailand can be the abundant cultural assets, good natural conditions, fascinating social customs, friendly local residents, economic tour packages, etc. However, some tour packages in Thailand have gained notoriety in the price war and poor service quality. Since 1999, Company M made a critical decision to get out of the sick price war and competition, and positioned itself as a tour company that provides high-quality, customer-oriented and personalized services, at the reasonable prices.

"Our company has invested significant efforts in innovation." Said the CEO. "Since 1999, we have developed several high-quality tour packages and gained positive criticism from the customers. In addition to the conventional sources of tourists like group travelers, we also provide personalized packages for the individual travelers. Our goal and strategy is to ensure that all tourists with different purposes can be satisfied and experience the most comfortable stay in Thailand."

"On the other hand, the company regards the employees as our most valuable properties." Continued the CEO. "All the employees, including the supporting staffs and the tour guides on the sites, are compensated with competitive salaries and benefits. Compared to our competitors, we invest and provide more opportunities in employee development. There are regularly workshops or seminars, which may help upgrade the work performance,

broaden the mindset, exchange experiences and problem-solving skills, and so on. During the storm of SARS, other tour companies just laid off the tour guides and staffs to survive. However, we sustain the coldest season with our employees by cost-saving as well as internal education and training. After the SARS disaster, the backflows of sightseers increase dramatically in the latter half of 2003. Most of our competitors became short of manpower and called the tourist guides on mission anxiously, but our company just got everything back to the normal situation with ease."

Despite the bright sides mentioned above, Company M still has its challenges and even threats. Growing from a small business toward a medium-sized enterprise, Company M has undergone the pains of authorization and structure reformation. Besides, the information delay and non-transparency reduce the responsiveness in marketing and amplify the time pressures. "Quite our information of end customers and markets are collected through the travel agents or wholesalers. They are who interact with the end customer, not us." The middle layers of information distributions usually result in information delay and inefficiency. At the supplier sides, the poorly automated transaction processes also become a burden on operations.

During 2003, the prime minister of Thailand has announced several new policies to the industry and commerce, including more rigid control over the tourist business and stricter tax policy. "We understand that the government's vision to upgrade this country and the whole environments; however, it is really tough for the business to change the conventions overnight." Complained the CEO.

Talking about the visions of Company M, some brilliant rays of light flash at the CEO's eyes. As one member of the tourism systems, Company M does not limit its role at the current position. In 2002, it achieved a phase objective to lead and became the top company in its target markets. The next-step of the strategic plan is to expand its role from a tour operator to an international travel enterprise group. "We expect the information systems to provide a communication platform between the end customers and us. All the travelers' demands or special requirements can be collected and met firsthand. The customers can also understand our products or enterprise through the Internet and submit their orders directly. There are no more essential needs of the middlemen between the customers and us." At the supplier side, Company M expects that information systems and the Internet work effectively as they would in at the customer side. Besides, it is developing a plan of backward integration for the future 5 to 10 years. "No matter how world goes on, we just keep proceeding with our goals." The CEO said full of meaning.

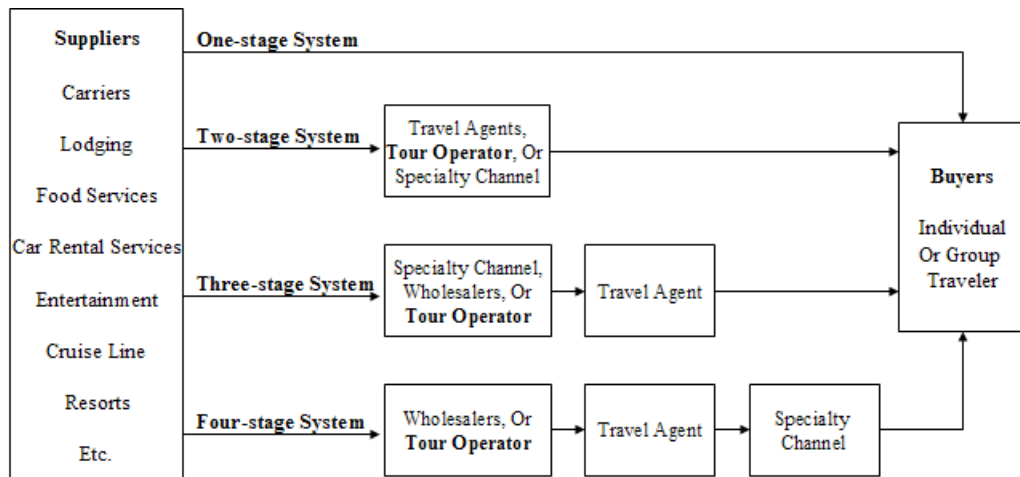

Fig. 1: Travel sales distribution system [5]

### 3. Implications and propositions from the case study

This study summarizes the strength, weakness, challenges, vision, and strategic approaches from the case company as Table 1.

Investigating the case deeply, this work extracts several propositions on the competition status of the international tourism and its impacts on the business investment and strategy forming. These propositions are listed as follow and illustrated as Fig. 2.

#### Proposition 1

*The more aggressive the vision and more distinct the business objectives of the tour company, the stronger the intentions of the business owner to invest significantly in information systems and technologies—If the business owners have more strong initiative and more clear objectives in business vision, then they have stronger motivations to invest significantly in information systems and technologies.*

#### Proposition 2

*The more intensive competition inside the target market, the greater the likelihood for the tour operator to invest substantially in information systems and technologies—If the competition inside the target market are more intense, then the business will sense much more deeply the essentiality to maintain and upgrade their competitive advantages in the industry, compared to the opposite circumstances.*

#### Proposition 3(a)

*The greater the degree of substitution from the potential competitors (such as airway holidays), the greater investment of employee development the tour operator willing to make—If the potential competitors are more likely to provide packages or services with equal or similar utilities at competitive costs, then the potential*

competitors will become more threatening. Hence the business owner will have more motivation to make investment in information systems and technologies to ensure their competitiveness.

#### Proposition 3(b)

*The greater the degree of substitution from the indirect competitors/substitutes (such as the tour packages whose destinations are in other Southeast Asian areas, Northeast Asian, Australia and New Zealand, Oceania, etc), the greater investment of employee development the tour operator willing to make—Similarly, if the indirect competitors are more likely to provide products or services with equal or similar utilities at attractive prices, then the indirect competitors or substitutes will become more threatening. Hence the business owner will have more motivation to make investment in information systems and technologies to assure their competitiveness.*

#### Proposition 4(a)

*The more aggressive the tour operator's objectives toward forward vertical integration in the tour industry, the more significant investment the tour operator willing to put into the business-to-business integration technologies—Intuitively, if the tour operator has clear and strong objectives toward forward vertical integration, then the business-to-business integration technologies will be a powerful instrument for this goal.*

#### Proposition 4(b)

*The more aggressive the tour operator's objectives toward backward vertical collaboration in the tour industry, the more significant investment the tour operator willing to put into the business-to-business collaboration technologies—Similarly, if the tour operator has aimed aggressively at backward vertical collaboration, then the business-to-business collaboration technologies will be a powerful instrument for this target.*

**Proposition 5**

*The more clear and definite the tour operator's objectives toward backward vertical collaboration in the tour industry, the more likelihood that the tour operator makes efforts to persuade its suppliers (such as hotels, restaurants, etc) into the business-to-business collaboration technologies—*This proposition is interrelated to Proposition 4(b). If the tour operator has definite objectives toward backward vertical collaboration, then the agreement and cooperation from the supplier side are very critical success factors. Therefore it will be motivated to win the supports from the supplier in business-to-business collaboration.

**Proposition 6**

*The more rigid control from the government, the more likelihood that the tour operator will diversify their capital investments and business operations—*The stricter legal and governmental environments cause the tour operator to diversify their business and capital investment for risk consideration.

In the following section, this paper will present the information system evolution in Company M, and how the information technologies, especially Web Services, can contribute to its vision from present through its long-term planning horizon.

Factor	Description
Vision	<ul style="list-style-type: none"> <li>● Maintaining the leading position in the market.</li> <li>● Forward integration from the current limited role of a tour operator, and get more control of the market through direct contact and communications with the end customers.</li> <li>● Backward integration with the suppliers, such as hotels, restaurants, entertainments, etc, to provide more guaranteed service quality for the tourists in the whole traveling processes.</li> <li>● Expand toward an integrated tourist enterprise group.</li> </ul>
Approaches	<ul style="list-style-type: none"> <li>● Advances for more effective and efficient knowledge management systems.</li> <li>● Establishing a learning organization to accelerate the improvement of the manpower as well as the company.</li> <li>● New information platform and new information architecture for business-to-business collaboration and forward integration.</li> </ul>

**Table 1: Summaries of the case tour operator**

Factor	Description
Strength	<ul style="list-style-type: none"> <li>● Good competition position in the industry.</li> <li>● Good relationships with the employees and competitive employee development strategies.</li> <li>● Innovations in product design.</li> <li>● Personalized services and customer oriented strategies.</li> </ul>
Weakness	<ul style="list-style-type: none"> <li>● Immature authorization.</li> <li>● Lack of professional expertise in information technologies and technical supports.</li> </ul>
Challenges	<ul style="list-style-type: none"> <li>● Pressures from business growth and transformation.</li> <li>● Changing governmental policies and more rigid legal environment.</li> <li>● Unpredictable natural disasters, such as SARS.</li> <li>● Uncontrollable economic depression or crises.</li> <li>● Vicious means from the competitors, such as the harmful price war.</li> </ul>

**4. Architecture of Web Services in international tourism.**

In this section, we first describe the past and current information system architecture of Company M and then design a new architecture based on Web Services, which contributes to the vertical collaboration and integration in international tourism supply chains.

The information system architecture of the company has evolved in three phases: (1) stand-alone file system, (2) client-server architecture, and (3) Business-to-Business integration model.

At the first phase from Aug. 1996 to Dec. 1999, the CEO of Company M focused on the requirements of financial accounting and arrangement of tour packages. Thus, the information system was simply stand-alone file systems. The specifications were as follow:

- Platform: Microsoft DOS.
- Programming Language: CA Clipper.
- Database: dBase III.
- Network Connection: Not available.

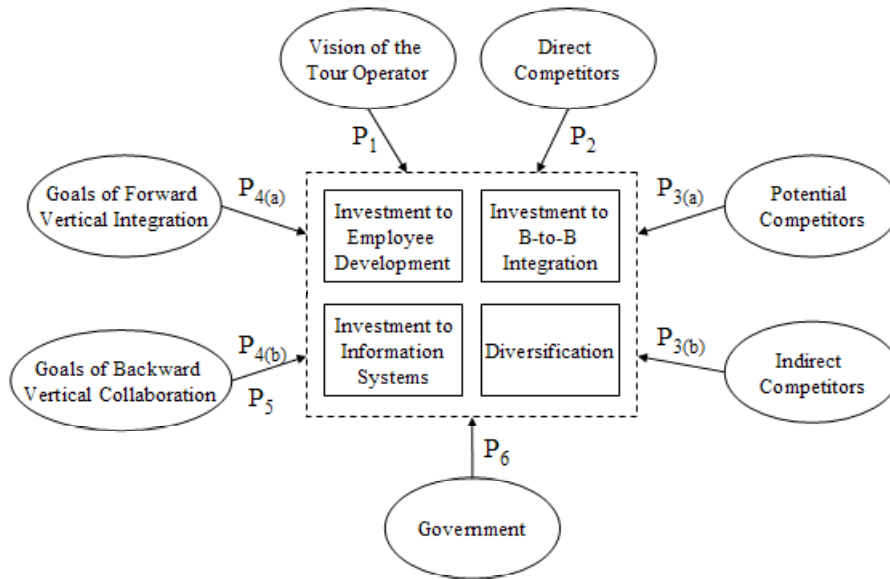
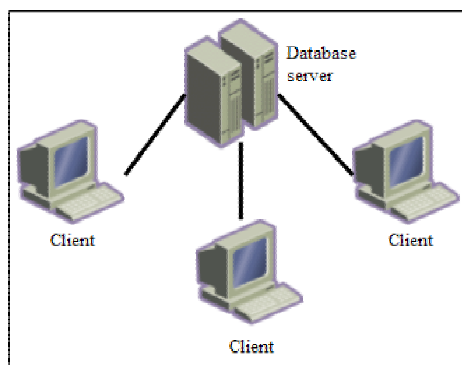

**Fig. 2: A model of forming competitive strategy in the international markets**

The drawbacks of the file system at this stage were:

- Data without synchronization and integrity.
- Lack of network connection.
- Difficulty to maintain and upgrade software.
- Lack of data management capabilities.

Since 2000, due to the drawbacks listed above, the CEO took the advice from one local information consulting company and decided to migrate the information system to client-server architecture (See Fig. 3).



**Fig. 3: Client-and-Server Architecture**

Based upon this idea, the information system at the second phase included:

- Platform: Microsoft Windows.
- Programming Language: Borland Delphi.

- Database Server: Microsoft SQL Server.
- Network Connection: with LAN Connection.

Although the client-server architecture resolved the problem of data synchronization and integrity intra-company, however, the information sharing extra-companies, such as among hotels, airlines, tour agents and tourists is still completed in the traditional ways, such as fax, e-mail, telephone and mail, which are inefficient and involving high transaction costs. Hence, seeking an efficient way to exchange information among business partners become a critical issue.

Although the World Wide Web (WWW) is a simple way to share information, WWW involves lots of human efforts to parse the HTML-format document. The web pages may appear informative to readers, but their logic behind are highly unstructured and lack a predefined schema. Thus, it is difficult to understand the semantic meaning of diverse web pages and structure them in an organized way for systematic information retrieval.

The objective of Business-to-Business integration (B2Bi) is to eliminate the manual processes by allowing internal applications of different companies to directly exchange information. Additionally, there are enormous advantages of B2Bi [6]:

- Strengthen business relationships with partners and customers.
- Fast to market.
- Reduced cycle times and increase operational efficiencies.
- Enhance customer relationship.
- Reduce operational costs.

Although many B2Bi vendors provide application packages to support the B2Bi activities and particular industrial standards, such as EDI, RosettaNet, ebXML, cXML and etc., it is still expensive, proprietary, and lacks of flexibility due to the difficulty in achieving consistency and consensus for the business model of the entire organization. Therefore, the B2Bi models are often implemented in larger-scale enterprises.

Opposed to the problems of B2Bi, Web Services have the following potentials in revolution of business process collaboration [6]:

- **Interoperability:** Web Services can be written in any language, and any Web Services can interact with any other Web Services easily with the open standard protocols such as Hypertext Transport Protocol (HTTP), XML, Simple Object Access Protocol (SOAP), Web Services Description Language (WSDL) and Universal Description, Discovery and Integration (UDDI).
- **Industry Support:** Web Services address the Interoperability issue by having the widest industry support. Many major software vendors have involved in supporting the Web Services standard.
- **Ubiquity:** Since Web Services communicate with open standard protocols, any platform that supports these protocols can host and access Web Services.

Web Services has the following advantages [7]:

- **Open Standards:** Unlike proprietary enterprise solutions, Web Services are based on open standards. The fact that they are built on existing and ubiquitous protocols eliminates the need for companies to invest in supporting new network protocols.
- **Simple:** Web Services are easy to design, develop, maintain, and use as compared to the existing solutions which may involve distributed technology.
- **Flexible:** Since proprietary enterprise solutions may require point-to-point integration, changes made at one end have to be propagated to the other end, making them very rigid and time consuming in nature. Web Services-based integration is quite flexible, as it is built on loose-coupling between the applications.
- **Efficient:** Web Services allow applications to be broken down into smaller components, which make the integration of applications easier as it is done on a granular basis.
- **Dynamic:** Web Services provide a dynamic approach to integration by offering dynamic interfaces, whereas traditional EAI solutions are pretty much static in nature.

Web Services are a common program-to-program communications model, built on existing standards. The Web Services model is based upon the interactions among Service Registry, Service Provider and Service Requestor. The interactions involve the Publish, Find and Bind operations. Web Services use SOAP based messages to achieve dynamic integration between two different applications. Using WSDL describes the public and private application services. Fig. 4 shows the relationships among the relevant standards:

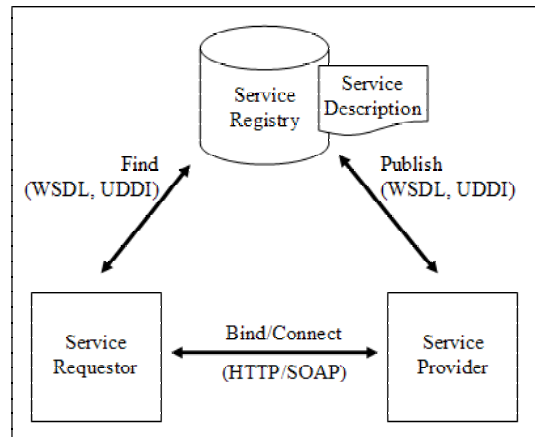
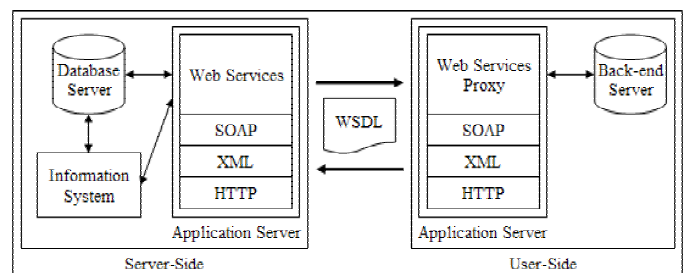

**Fig. 4: Web Services Model [8]**

The following summaries are the additional requirements from CEO of Company M at the third phase for Business-to-Business integration:

- Rapidly deployment.
- Reduce operational cost.
- Increase competitive advantage.
- Forward compatibility.
- Ease of installation and management.

Thus, based upon the summaries above, the Web Services Business-to-Business integration model is designed (Fig. 5):

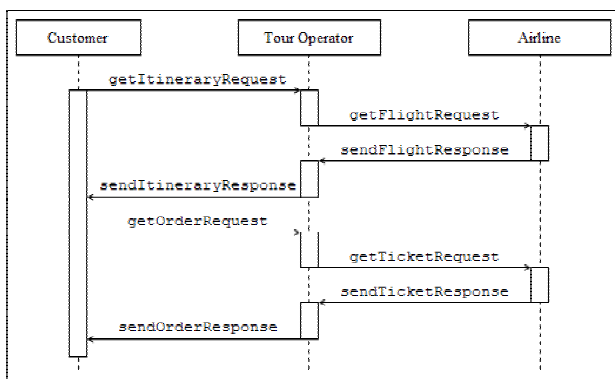

**Fig. 5: Web Services B2Bi Model**

The specifications of Web Services B2Bi model are:

- Platform: Microsoft Windows .NET platform.
- Application Server: Microsoft Internet Information Server.
- Database Server: Microsoft SQL Server.
- Program Language for Web Services: Visual Basic .NET.

Fig 6 shows the example of sequence diagram for the activities in this model to describe how the groups of objects interact with each other among tour operator, airlines and customers including tour wholesalers, tour agents and end travelers.



**Fig. 6: Sequence diagram**

Web Services represent a significant step in the evolution of Business-to-Business integration. The capabilities of Web Services allow companies to provide a front-end integration with existing application services, wrap up back-end enterprise systems as Web Services and integrate intra- and extra-services as a whole business process.

## 5. Discussions and conclusions

This study investigates a regional tour operator in Thailand specializing in providing tour packages for the inbound tourists from Asia, especially Taiwan and Hong Kong. Observing from various dimensions, the authors summarize the strength, weakness, challenges, vision and strategies of the case company. Then, this research extracts several managerial implications and propositions through the case analysis, and designs the architecture of business-to-business collaboration and integration for an international tourist enterprise to ensure its competitive advantages. This study develops the architecture under the belief that information systems and technologies can ensure and upgrade the competitiveness in highly competitive international tourist markets.

## References

- [1] Lynda M. Applegate, F. Warren McFarlan and James L. McKenney, *Corporate Information System Management*, McGraw-Hill International Editions, 1999
- [2] Kenneth C. Laudon and Jane P. Laudon, *Management Information Systems*, Prentice Hall International Editions, 2000.
- [3] Michael E. Porter and Victor E. Millar, "How Information Gives You Competitive Advantage", *Harvard Business Review*, July-August 1985
- [4] Weaver, D. and M. Oppermann, *Tourism management*, John Wiley and Sons Australia, 2000.
- [5] Gee, C. Y., J. C. Makens and D. J. L. Choy, *The travel industry*, Van Nostrand Reinhold, 1989.
- [6] webMethods, "Implementing Enterprise Web Services with webMethods Integration Platform", webMethods Inc., 2002
- [7] Gunjan Samtani and Dimple Sadhwani, "EAI and Web Services-Easier Enterprise Application Integration?", <http://www.webservicesarchitect.com>, October 17, 2001
- [8] Heather Kreger, "Web Services Conceptual Architecture (WSCA 1.0)", IBM Software Group, 2001