

Association for Information Systems AIS Electronic Library (AISeL)

AMCIS 2011 Proceedings - All Submissions

8-6-2011

An Empirical Study of Health Consumer Beliefs, Attitude and Intentions toward the Use of Self- Service Kiosks

Jason F. Cohen

Wits University and Ivey Centre for Health Innovation and Leadership, UWO, jason.cohen@wits.ac.za

Shaun D. Sergay

Wits University, shaunsergay@gmail.com

Follow this and additional works at: http://aisel.aisnet.org/amcis2011_submissions

Recommended Citation

Cohen, Jason F. and Sergay, Shaun D., "An Empirical Study of Health Consumer Beliefs, Attitude and Intentions toward the Use of Self-Service Kiosks" (2011). *AMCIS 2011 Proceedings - All Submissions*. 46.

http://aisel.aisnet.org/amcis2011_submissions/46

This material is brought to you by AIS Electronic Library (AISeL). It has been accepted for inclusion in AMCIS 2011 Proceedings - All Submissions by an authorized administrator of AIS Electronic Library (AISeL). For more information, please contact elibrary@aisnet.org.

An Empirical Study of Health Consumer Beliefs, Attitude and Intentions toward the Use of Self-Service Kiosks

Jason F. Cohen

Wits University and Ivey Centre for Health
Innovation and Leadership, UWO
jason.cohen@wits.ac.za

Shaun D. Sergay

Wits University
shaunsergay@gmail.com

ABSTRACT

There is increasing interest in reaching and empowering patients and health consumers directly through information technology (IT). However, consumer readiness for an increasingly IT-enabled healthcare system has been questioned and there remains a need for more theory driven research into IT adoption by health consumers. This study has contributed by examining the influence of selected individual difference variables on health consumer beliefs, attitudes and intentions toward the use of self-service kiosks in healthcare. A survey of 192 patients in two private healthcare clinics operating in urban centers in South Africa was carried out. Results show that four individual difference variables, namely computer anxiety, self-efficacy, need for interaction, and trust are significant predictors of patient beliefs and attitude. Expected ease-of-use was found the strongest predictor of adoption intentions.

Keywords

Health consumer, self-service, technology acceptance, technology adoption, electronic health systems.

INTRODUCTION

The application of information technology (IT) to address problems in healthcare delivery, patient safety and clinical practice is gaining attention in both research and practice. Most contributions focus on hospital information systems and clinician-oriented applications such as electronic health records, clinician decision support systems and computerized provider order entry (e.g. Kaplan, 2001; Kaushal, Shojania and Bates, 2003; Poissant, Pereira, Tamblyn and Kawasumi, 2005; Prgomet, Georgiou and Westbrook, 2009). However, there is increasing interest in reaching and empowering health consumers directly through IT. Consumer health informatics and the use of self service technologies (SSTs) are positioned to become integral parts of the modern concept of public health – as solutions to spiraling healthcare costs and a means for consumers to independently produce and actively engage in their own healthcare process (Eysenbach, 2000; Whetton, 2005; Jung and Berthon, 2009).

The self-service kiosk is a specific type of SST being implemented in healthcare facilities. They are usually deployed on large screen touch panels or smaller monitor and keypad combinations. Interest in the technology is growing across hospitals in the US, Canada and Europe where they are being positioned in entrance lobbies and admissions areas as well as emergency rooms, outpatient clinics, cancer centers and pediatric clinics. Once integrated with other backend hospital and patient database systems, these kiosks typically allow patients to maintain their personal information and medical insurance details, self-register and check-in for prearranged appointments, review appointment details, complete pre-assessment questionnaires, confirm future appointments, review physician order details, check out, and capture their patient reported outcome measures. Some solutions assist more directly in the patient triage and assessment process by allowing patients to provide details of symptoms or in taking patient vital signs. Others provide maps and virtual tours of a health centre to enable patients to direct themselves to locations for consultation and treatment. Self-service kiosks aim to provide a more cost effective way of handling patient arrivals by automating routine processes, reducing paperwork and clerical errors, eliminating delays and overcrowding, improving the routing of patients through the hospital system, reducing pressure on reception staff, helping staff to prioritize treatment, and allowing for hospital staff to be reallocated away from scheduling and registration activities toward patient care (Wiler, Gentle, Halfpenny, Heins, Mehrotra, Mikhail and Fite, 2010).

Yet, interesting questions arise as to the appropriateness of such technologies within a medical setting, and whether health consumers would be willing to trust and embrace such technologies in the healthcare context. While some consumers may

welcome the convenience and time saving brought about by the technology as well as the added opportunity to communicate and share information with their healthcare provider; others may fear the loss of personal contact with service staff and the consequences of making mistakes. Usability amongst the elderly and persons with disabilities has already been questioned¹ and recent research suggests that many kiosk implementations have failed to become part of routine service delivery and most have been withdrawn (Jones, 2009). Therefore, it is necessary to determine the extent to which consumers would accept these types of SSTs as useful and desirable, and thus whether the implementation of these technologies can improve the health consumer's hospital experience and ensure the delivery of high quality, cost-effective healthcare.

The purpose of this study is to develop and test a model of the factors influencing health consumer beliefs, attitudes and intentions toward the use of the self-service kiosk. Specifically, we build on extant theories of technology acceptance to examine the effects of various individual difference variables (computer anxiety, self-efficacy, need for interaction, and trust) on health consumer beliefs, attitudes and intentions. In doing so, we overcome the general lack of theory-driven research into consumer acceptance of health information technologies (Or and Karsh, 2009).

The next section of this paper discusses the theoretical underpinnings to the research model and presents the study's hypotheses. This is followed by a description of the research methods, presentation of the empirical findings and conclusions.

HYPOTHESES AND RESEARCH MODEL

The technology acceptance model (TAM) (Davis, Bagozzi and Warshaw, 1989) has demonstrated itself as effective, parsimonious and applicable across numerous contexts and we consider it an appropriate theoretical framework from which to study patient readiness for healthcare SSTs. In the health informatics literature TAM has been frequently applied in the study of clinicians and other healthcare workers (see Holden and Karsh, 2009) and the study of health consumers (Jung and Berthon, 2009; Wilson and Lankton, 2004; Lanseng and Andreassen, 2007).

The dependent variable of our research model (Figure 1) is behavioral intention to use a self-service kiosk for tasks such as registration, check-in and admission to a medical facility. We focus on behavioral intentions rather than actual usage because the widespread diffusion of these technologies into hospital and clinic contexts has not yet occurred and thus patterns of actual usage have not yet emerged. Figure 1 illustrates the direct and mediated effects of attitude, expected usefulness (EU) and ease-of-use (EEOU) on behavioral intention.

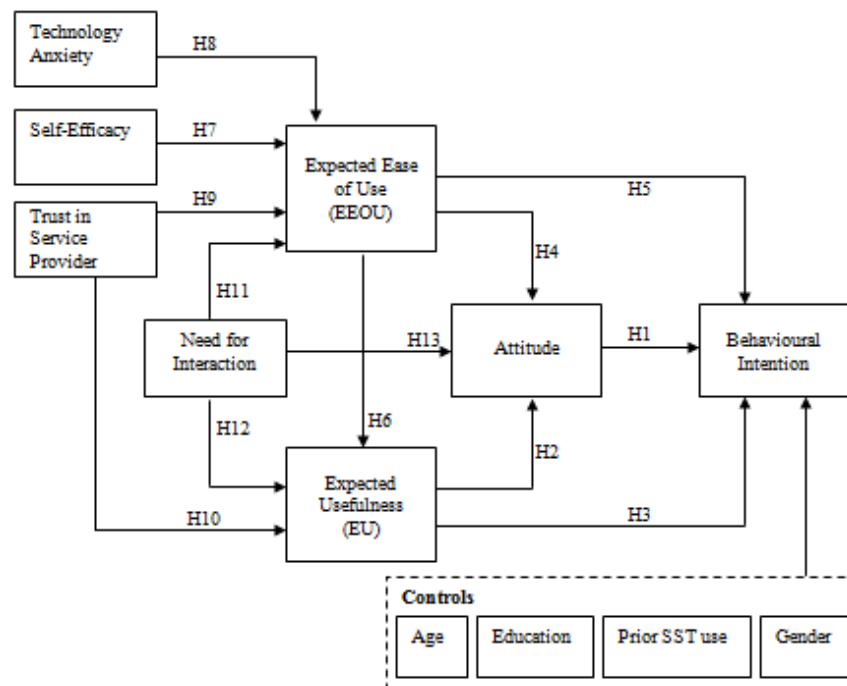

Figure 1. Research Model

¹ <http://www.walletpop.ca/blog/2010/05/15/the-robotic-nurse-automated-hospital-check-in-is-coming/>

Figure 1 also includes various individual difference variables, namely computer anxiety, self-efficacy, need for interaction, and trust in the healthcare provider as determinants of EU and EEOU. Venkatesh (2000) argued that individual difference variables are particularly important to explanations of behavior and should be considered in technology acceptance studies for their roles as ‘anchors’ in the formation of beliefs about using a target system especially those in the early stages of user experience. Therefore, as technologies move beyond the workplace and emerge in diverse usage contexts such as health care, it becomes important to understand the relative effects of such variables and the role they play as enablers or inhibitors to technology acceptance.

Attitude, Expected Usefulness and Expected Ease of Use

Within TAM, there are two primary beliefs. The first is perceptions of system usefulness i.e. the degree to which a person believes that using the system would enhance task performance (Davis, 1993). Unless SST usage is mandatory, consumers will have a choice between an interpersonal encounter or a technology based encounter. Technology based encounters are unlikely to be the preferred option if the consumer does not perceive an advantage for using it (Meuter et al., 2003). The second belief is perception of the system’s ease of use (Davis, 1993). Technologies that are perceived as easier to use and less complicated will have a higher likelihood of acceptance (Agarwal and Prasad, 1999). If adoption is to occur, the effort to use the SST must be considered less than the effort to interface with the service employee. Moreover, according to TAM, the easier a system is to use, the more likely a user will believe in the usefulness of the system (Davis et al., 1989).

Beliefs about the technology’s usefulness and ease of use will lead to the formulation of an attitude toward using the system (Davis et al., 1989). Attitude has been found an important predictor of user intentions in numerous contexts (e.g. Wixom and Todd, 1995; Lanseng and Andreassen, 2007). Following from the above, we hypothesize:

H1: An individual’s (positive) attitude toward SST use is positively associated with their behavioral intention

H2 and H3: An individual’s expectation of usefulness is positively associated with their attitude toward SST use and with their behavioral intention

H4, H5 and H6: An individual’s expectation of ease of use is positively associated with their expectation of usefulness; with their attitude toward SST use and with their behavioral intention

Self-Efficacy

Self-efficacy is an individual’s subjective assessment of their capability to perform (Bandura, 1982). A person with high self-efficacy will confidently perceive themselves able to accomplish more difficult tasks, with less support, in more diverse situations (Bandura, 1982). The concept of self-efficacy has been successfully applied in technology acceptance research (Taylor and Todd, 1995; Compeau and Higgins, 1995). Technology acceptance theory suggests that individuals will anchor their perceptions of how easy or difficult they would find it to use a new system, *inter-alia*, on their self-efficacy beliefs to perform specific tasks using the technology (Venkatesh, 2000). We thus hypothesize:

H7: An individual’s self-efficacy is positively associated with their expectation of the SST’s ease of use

Anxiety

Computer anxiety is the affective response of individuals when they use (or consider the possibility of using) computers and will manifest as worries, apprehensions, tensions and fear (Heinssen et al., 1987). Computer anxious individuals are more reluctant to use computers (Bozionelos, 2004), will generally avoid them (Chua et al., 1999), and may perform more poorly on computer-based tasks (Mahar et al., 1997). Venkatesh (2000) found that anxiety has a negative impact on system-specific perceived ease of use. We thus hypothesize:

H8: An individual’s technology anxiety is negatively associated with their expectation of the SST’s ease of use

Trust in Healthcare Provider

We define trust as the user’s beliefs in the competence, reliability and benevolence of the healthcare provider. We follow Gefen et al. (2003); Pavlou (2003) and Lanseng and Andreassen (2007) in modeling trust as antecedent to the formation of beliefs about system usefulness and ease of use. Trust reduces uncertainty and provides expectations of a satisfactory electronic transaction (Pavlou, 2003). Without trust, a consumer has no reason to expect to gain any utility (usefulness) from the electronic interface. Moreover, trust reduces the consumer’s need to monitor and control every facet and detail of the interaction thereby reducing the time and effort required and making the electronic transaction easier (Pavlou, 2003). Therefore we hypothesize that:

H9 and H10: An individual's trust in their healthcare service provider is positively associated with their expectation of the SST's ease of use and with their expectation of the SST's usefulness

Need for Interaction

SSTs require consumers to change their behaviors to become co-producers with responsibility for delivery of the service and their own satisfaction (Meuter et al., 2005). Consumers will thus need to be sufficiently intrinsically and extrinsically motivated to make this change and to receive the rewards associated with SST use (Meuter et al., 2005). However, it has been established that many consumers still prefer to deal with other people rather than with technology (Dabholkar, 1996). Consumers with this high need for interaction are not expected to desire an active role in the production of service and are thus not expected to find SST use intrinsically attractive (Dabholkar and Bagozzi, 2002). People with a high need for interaction are also expected to perceive less need for the convenience of an SST and have a lower desire for control over service production and thus they lack the extrinsic motivation required for SST use (Meuter et al., 2005). Consequently, we believe that individuals with a high need for interaction will have decreased interest in learning how SSTs work and reduced motivation to use them (Meuter et al., 2005). They are also likely to require the technology to be easier to use and more reliable for them to form a favorable attitude toward the use of SSTs for service delivery (Dabholkar and Bagozzi, 2002). We thus hypothesize:

H11, H12 and H13: An individual's need for interaction is negatively associated with their expectation of the SST's ease of use; with their expectation of the SST's usefulness and with their attitude toward SST usage

Controls

The technology acceptance, consumer behavior and innovation literatures have recognized that people who adopt new technologies tend to be younger, male, and more educated. Moreover, because adoption of e-health has been found related to prior experience with the Internet and other e-services (Muhdi and Boutellier, 2010), we include prior usage of SSTs as an additional control.

RESEARCH METHODOLOGY

Instrument

A structured questionnaire instrument was developed for data collection. Respondents were presented with a scenario that helped familiarize them with a typical usage scenario for a self-service kiosk. The scenario described the use of an SST for registration and admission to their medical facility for non-urgent treatment. Unless otherwise stated all items were measured on a 5-point scale. Behavioral intention was measured using two items reflecting the patient's intention and preference for the use of a self-service kiosk to facilitate admission to the medical facility for the scenario described. Attitude toward SST use was measured using a four item 7-point semantic-differential scale along the attribute dimensions of good-bad, harmful-beneficial, pleasant-unpleasant, and favourable-unfavourable (Ajzen, 2001). Expected ease of use was measured using four statements asking patients whether or not they expect they would find such a system complicated, time consuming, confusing and requiring of substantial effort to use (Dabholkar, 1994; Lanseng and Andreassen, 2007). Expected usefulness was measured using five items tapping into the patient's belief that the SST would produce positive results such as increasing their feelings of control, improving the speed of admission, and reducing their waiting time. Patients need for interaction was measured using three items asking patients the extent to which personal attention was important to them and their preference for face to face interaction (Dabholkar and Bagozzi, 2002). Computer anxiety was measured using four items adapted from Meuter et al. (2003). Items asked about apprehension, fear and intimidation in relation to SST usage for the scenario provided. Self-efficacy was measured using three items from Venkatesh and Bala (2008). These items tapped into the patient's confidence in their ability to complete the required tasks using the SST. Trust in the healthcare service provider was adapted from Lanseng & Andreassen (2007). Four items captured the patient's trust in the medical facility to provide an SST that is secure, reliable and accurate and that has the patient's best interests in mind. A demographics section captured data on the control variables: gender, age, education level, and prior SST use. Finally, to improve our understanding of consumer's general readiness for healthcare SSTs we asked about willingness to use STTs for a variety of healthcare services including administrative activities (e.g. making an appointment to see a physician) and treatment related activities (e.g. evaluating the risks and payoffs of certain medical treatments).

Data Collection

Ethics clearance was obtained from the relevant institutional review board. The survey was administered to patients and accompanying family members awaiting admission into two private healthcare clinics operating in urban centers in South

Africa. The first was a clinic offering the services of general practitioners, radiology, pathology, executive and travel health services, baby clinic, dental services, psychiatric services, audiology, physiotherapy, and podiatry amongst other services. This clinic is part of a medium sized private healthcare group operating across South Africa. The second clinic specializes in orthopedic surgery, sports medicine and rehabilitation and is attached to a large private hospital in the Johannesburg area. The surveying of patients in private healthcare clinics resulted in a methodological control for socio-economic status as only patients able to afford private healthcare were being admitted to these facilities. The data collection process took place over a two week period. All individuals surveyed were over 18 years of age.

DATA ANALYSIS AND RESULTS

Response and Sample Profile

In total, 249 responses were received. However, 57 were eliminated as they were missing a large number of data values. The final sample consisted of 192 observations with sufficient data for meaningful statistical analysis. Table 1 presents a description of the sample profile across the two clinic sites. Chi-squared tests revealed no significant difference between the two sites on the demographic profile of respondents. The data was thus pooled for subsequent analysis.

As part of the survey, we asked patients to indicate the extent to which they would be willing to use SSTs for a number of health-related services. Table 2 presents the results in descending order and shows that patients are most willing to carry out healthcare related administrative activities (highlighted in light grey) than to use SSTs for diagnostic and treatment related activities (highlighted in dark grey). This suggests that the benefits patients currently desire from SSTs are those that will lower costs, reduce time, provide greater control and independence and allow patients to more successfully access healthcare services.

	Site 1	Site 2	Total
Total	104	88	192
Age			
18-25	11	15	26
26-40	55	22	77
41-55	29	33	62
56 +	7	13	20
Missing	2	5	7
Gender			
Male	41	44	85
Female	63	44	107
Level of Education			
Less Than 12 Yrs	0	1	1
High School	7	12	19
Some College/Univ	34	28	62
University Graduate	35	23	58
Postgraduate Degree	28	23	51
Missing	0	1	1
Prior Use of Self-Service Kiosks			
Yes	72	63	135
No	32	25	57

Table 1: Sample Profile

I would use self-service technologies to:	Disagree or Strongly Disagree	Neutral	Agree or Strongly Agree
	%	%	%
Pay my medical treatment bill	3.7	4.2	92.2
Make an appointment to see a physician	4.1	3.6	92.2
Retrieve a prescription	3.6	4.7	91.7
Register preferences (e.g. meals, room and entertainment) prior to an overnight admission	0	9.4	90.6
Maintain my personal information and medical history	4.1	10.4	85.4
Find out more about a specific health related issue	6.7	9.9	83.3
Retrieve results of a laboratory / medical test	9.4	9.9	80.8
Register my presence in an emergency room on arrival	9.3	11.5	79.1
Evaluate the risks and payoffs of certain medical treatments	8.3	14.1	77.6
Disclose personal information, history that I may feel uncomfortable doing in person	13	28.1	58.9
Perform a self-diagnosis	41.6	22.4	35.9

Table 2: Willingness of Patients to Use SSTs

Table 2 also shows that the willingness of patients to use an SST to facilitate admission to an emergency room ranks amongst the lowest desired uses for SSTs with fewer than 80% of patients responding favourably. The next section tests our research model (Figure 1) and provides us an improved understanding of this variation in response.

Measurement Model

The PLS approach to SEM was employed to test the study's hypotheses. PLS-Graph ver 3.00 build 1126 was used. Table 3 presents results of the test of the measurement model. Individual indicator reliability is established as all loadings exceed 0.60 and were significant. Scale reliability of the constructs is established as the Fornell and Larcker measures of internal consistency are all greater than 0.7. Examination of the average variance extracted (AVE) for each latent construct shows that all have AVE's in excess of 0.5 indicating that the constructs explain more than 50% of the variance in their observed measures. Convergent validity is thus established. A matrix of inter-construct correlations with the square root of each construct's AVE plotted along the diagonal (Table 4) shows that the variance shared between any two constructs is less than the variance shared between a construct and its own indicators. Thus confirming discriminant validity.

Structural Model

Figure 2 presents the test of the structural model after controlling for age, gender, education and prior SST experience. The significance of the paths was determined by bootstrap resampling. Results confirm the impacts of anxiety, self-efficacy, trust and need for interaction on expected ease of use, and together they explained almost 60% of its variance. This supports H7, H8, H9 and H11. Paths linking trust (H10) and ease of use (H6) to usefulness were both significant. However, our hypothesis that need for interaction would reduce a patient's perception of the utility of an SST (H12) was not supported. Need for interaction (H13) and expected usefulness (H2) significantly predicted attitude, which in turn had effects on intention (H1). Interestingly, in this pre-usage context, expectations for ease of use (H5) rather than usefulness had direct effects on intention. H3 and H4 were rejected. 54% of the variance in intention was explained by the model. None of the control variables had significant effects on behavioral intention.

Construct and Indicators	Item Loadings	Internal Consistency ^a	AVE ^b	Cronbach's α
Anxiety		0.901	0.695	0.852
AN1	0.805			
AN2	0.844			
AN3	0.855			
AN4	0.830			
Self-Efficacy		0.866	0.683	0.771
SE1	0.883			
SE2	0.764			
SE3	0.828			
Need for Interaction		0.925	0.805	0.879
NFI1	0.875			
NFI2	0.914			
NFI3	0.902			
Trust		0.901	0.695	0.855
TR1	0.826			
TR2	0.837			
TR3	0.856			
TR4	0.814			
Expected Ease of Use		0.911	0.720	0.866
EEOU1	0.787			
EEOU2	0.906			
EEOU3	0.891			
EEOU4	0.804			
Expected Usefulness		0.869	0.572	0.796
EU1	0.629			
EU2	0.783			
EU3	0.814			
EU4	0.701			
EU5	0.836			
Attitude		0.937	0.789	0.910
ATT1	0.888			
ATT2	0.863			
ATT3	0.896			
ATT4	0.904			
Behavioral Intention		0.874	0.777	0.717
BI1	0.913			
BI2	0.848			

Table 3: Tests of the Measurement Model

a Fornell and Larcker's internal consistency measure.

b Average variance extracted (AVE) used to establish convergent validity.

	Anxiety	SE	NFI	Trust	EEOU	EU	Attitude	BI
Anxiety	0.833							
SE	-0.486	0.826						
NFI	0.648	-0.280	0.897					
Trust	-0.440	0.488	-0.369	0.834				
EEOU	-0.686	0.530	-0.579	0.548	0.849			
EU	-0.450	0.378	-0.436	0.595	0.652	0.756		
Attitude	-0.475	0.241	-0.499	0.434	0.489	0.593	0.888	
BI	-0.513	0.259	-0.540	0.361	0.570	0.554	0.674	0.881

Table 4: Correlation Matrix

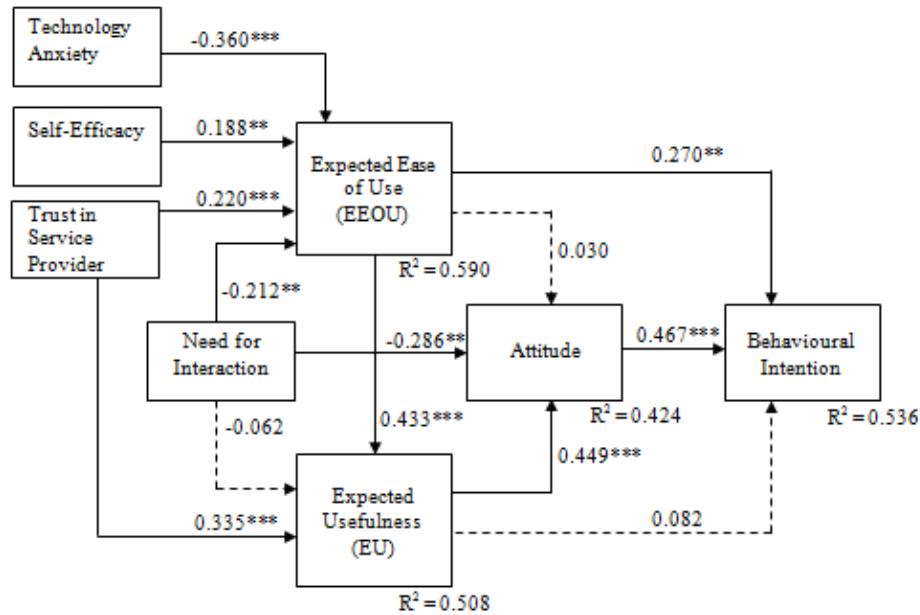

Figure 2: PLS Results

** p<0.01 *** p<0.001

DISCUSSION AND CONCLUSION

This study overcame the general lack of tests for the effect of individual level variables on IT acceptance by confirming hypotheses H7 through H11 as well as H13. H12 was rejected suggesting that even patient’s with a high need for interaction may still perceive SSTs as inherently useful. Our empirical findings also suggest that in a context where users lack direct hands-on experience with the technology, ease-of-use rather than usefulness has a stronger direct effect on intentions. Moreover, the strong significant effects of the individual difference variables on expected ease-of-use illustrates that the introduction of health IT solutions faces unique challenges related to a diverse user base. Lack of trust, patient anxieties, need for interaction and lack of technology confidence are significant barriers to the formation of positive beliefs about self-service technologies that will need to be overcome.

Future work can extend this research project to explore the acceptance of self-service kiosks in public as opposed to private health care facilities. Moreover, future studies should consider health consumer readiness for SSTs in specific contexts such as in treatment programs for chronic disease e.g. diabetes or within aged care programs. By providing patient’s with direct access to their own health information, these SSTs impact on established roles and relationships between health providers,

clinicians and consumers. Future research should explore clinician response to the implementation of these SSTs and track both the advantages and disadvantages arising from their use.

REFERENCES

1. Agarwal, R. and Prasad, J. (1999) Are individual differences germane to the acceptance of new information technologies?, *Decision Sciences*, 30, 2, 361-391.
2. Ajzen, I. (2001) Nature and operation of attitudes, *Annual Review of Psychology*, 52, 1, 27-58.
3. Bandura, A. (1982) Self-efficacy mechanism in human agency, *American Psychologist*, 37, 2, 122-147.
4. Benamati, J., Fuller, M.A., Serva, M.A. and Baroudi, J. (2010) Clarifying the integration of trust and TAM in e-commerce environments: Implications for systems design and management, *IEEE Transactions on Engineering Management*, 57, 3, 380-393.
5. Bozionelos, N. (2004) Socio-economic background and computer use: The role of computer anxiety and computer experience in their relationship, *International Journal of Human-Computer Studies*, 61, 5, 725-746.
6. Chua, S.L., Chen, D. and Wong, A.F.L. (1999) Computer anxiety and its correlates: A meta-analysis, *Computers and Human Behavior*, 15, 5, 609-623.
7. Compeau, D.R. and Higgins, C.A. (1995) Computer self-efficacy: Development of a measure and initial test, *MIS Quarterly*, 19, 2, 189-211.
8. Dabholkar, P.A. (1994) Incorporating choice into an attitudinal framework: Analyzing models of mental comparison processes, *Journal of Consumer Research*, 21, 1, 100-118.
9. Dabholkar, P.A. (1996) Consumer evaluations of new technology-based self service options: An investigation of alternative models of service quality, *International Journal of Research in Marketing*, 13, 1, 29-51.
10. Dabholkar, P.A. and Bagozzi, R.P. (2002) An attitudinal model of technology-based self-service: Moderating effects of consumer traits and situational factors, *Journal of the Academy of Marketing Science*, 30, 3, 184-201.
11. Davis, F.D. (1993) User acceptance of information technology: System characteristics, user perceptions and behavioral impacts, *International Journal of Man-Machine Studies*, 38, 3, 475-487.
12. Davis, F.D., Bagozzi, R.P. and Warshaw, P.R. (1989) User acceptance of computer technology: A comparison of two theoretical model, *Management Science*, 35, 8, 982-1003.
13. Eysenbach, G. (2000) Consumer health informatics, *British Medical Journal*, 320, 7251, 1713-1716.
14. Gefen, D., Karahanna, E. and Straub, D.W. (2003) Trust and TAM in online shopping: An integrated model, *MIS Quarterly*, 27, 1, 51-90.
15. Heinssen, R.K., Glass, C.R. and Knight, L.A. (1987) Assessing computer anxiety: Development and validation of the computer anxiety rating scale, *Computers and Human Behavior*, 3, 1, 49-59.
16. Holden, R.J. and Karsh, B. (2009) The technology acceptance model: Its past and its future in health care, *Journal of Biomedical Informatics*, 43, 1, 159-172.
17. Igbaria, M., Guimaraes, T. and Davis, G.B. (1995) Testing the determinants of microcomputer usage via a structural equation model, *Journal of Management Information Systems*, 11, 4, 87-114.
18. Jones, R. (2009) The role of health kiosks in 2009: Literature and informant review, *International Journal of Environmental Research and Public Health*, 6, 6, 1818-1855.
19. Jung, M. and Berthon, P. (2009) Fulfilling the promise: A model for delivering successful online health care, *Journal of Medical Marketing*, 9, 3, 243-254.
20. Kaplan, B. (2001) Evaluating informatics applications—clinical decision support systems literature review, *International Journal of Medical Informatics*, 64, 1, 15-37.
21. Kaushal, R., Shojania, K.G. and Bates, D.W. (2003) Effects of computerized physician order entry and clinical decision support systems on medication safety: A systematic review, *Archives of Internal Medicine*, 163, 12, 1409-1416.
22. Lanseng, E.J. and Andreassen, T.W. (2007) Electronic healthcare: A study of people's readiness and attitude toward performing self-diagnosis, *International Journal of Service Industry Management*, 18, 4, 394-417.
23. Mahar, D., Henderson, R. and Deane, F. (1997) The effects of computer anxiety, state anxiety, and computer experience on users' performance of computer based tasks, *Personality and Individual Differences*, 22, 5, 683-692.

24. Malhotra, Y. and Galletta, D.F. (1999) Extending the technology acceptance model to account for social influence: Theoretical bases and empirical validation, *Proceedings of the 32nd Hawaii International Conference on System Sciences (HICS-32)*, Jan 05 - 08, Maui, HI, USA, IEEE.
25. Meuter, M.L., Bitner, M.J., Ostrom, A.L. and Brown, S.W. (2005) Choosing among alternative service delivery modes: An investigation of customer trial of self-service technologies, *Journal of Marketing*, 69, 2, 61–83.
26. Meuter, M.L., Ostrom, A.L., Bitner, M.J. and Roundtree, R.I. (2003) The influence of technology anxiety on consumer use and experiences with self-service technologies, *Journal of Business Research*, 56, 11, 899-906.
27. Meuter, M.L., Ostrom, A.L., Roundtree, R.I. and Bitner, M.J. (2000) Self-service technologies: Understanding customer satisfaction with technology-based service encounters, *Journal of Marketing*, 64, 3, 50-64.
28. Morris, M.G. and Venkatesh, V. (2000) Age differences in technology adoption decisions: Implications for a changing work force, *Personnel Psychology*, 53, 2, 375-403.
29. Muhdi, L. and Boutellier, R. (2010) Diffusion of potential health related e-services: An analysis of Swiss health consumer perspectives, *Journal of Management and Marketing in Healthcare*, 3, 1, 60-72.
30. Or, C. and Karsh, B. (2009) A systematic review of patient acceptance of consumer health information technology, *Journal of the American Medical Informatics Association*, 16, 4, 550-560.
31. Pavlou, P.A. (2003) Consumer acceptance of electronic commerce: Integrating trust and risk with the technology acceptance model, *International Journal of Electronic Commerce*, 7, 3, 69–103.
32. Poissant, L., Pereira, J., Tamblyn, R. and Kawasumi, Y. (2005) The impact of electronic health records on time efficiency of physicians and nurses: A systematic review, *Journal of the American Medical Informatics Association*, 12, 5, 505-516.
33. Prgomet, M., Georgiou, A. and Westbrook, J.I. (2009) The impact of mobile handheld technology on hospital physicians' work practices and patient care: A systematic review, *Journal of the American Medical Informatics Association*, 16, 6, 792-801.
34. Taylor, S. and Todd, P.A. (1995) Understanding information technology usage: A test of competing models, *Information Systems Research*, 6, 2, 144-176.
35. Venkatesh, V. (2000) Determinants of perceived ease of use: integrating control, intrinsic motivation, and emotion into the technology acceptance model, *Information Systems Research*, 11, 4, 342-365.
36. Venkatesh, V. and Bala, H. (2008) Technology acceptance model 3 and a research agenda on interventions, *Decision Sciences*, 39, 2, 273-315.
37. Venkatesh, V. and Morris, M.G. (2000) Why don't men ever stop to ask for directions? Gender, social influence, and their role in technology acceptance and usage behavior, *MIS Quarterly*, 24, 1, 115-139.
38. Venkatesh, V., Morris, M.G., Davis, G.B. and Davis, F.D. (2003) User acceptance of information technology: Toward a unified view, *MIS Quarterly*, 27, 3, 425-478.
39. Whetton, S. (2005) *Health informatics: A socio-technical perspective*, Oxford University Press, Melbourne.
40. Wiler, J.L., Gentle, C., Halfpenny, J.M., Heins, A., Mehrotra, A., Mikhail, M.G. and Fite, D. (2010) Optimizing emergency department front-end operations, *Annals of Emergency Medicine*, 55, 2, 142-160.
41. Wilson, E.V. and Lankton, N.K. (2004) Modeling patients' acceptance of provider-delivered e-health, *Journal of the American Medical Informatics Association*, 11, 4, 241-248.
42. Wixom, B.H. and Todd, P.A. (2005) A theoretical integration of user satisfaction and technology acceptance, *Information Systems Research*, 16, 1, 85-102.