

## Association for Information Systems AIS Electronic Library (AISeL)

---

AMCIS 2011 Proceedings - All Submissions

---

8-7-2011

# An Ontological Approach to XBRL Financial Statement Reporting

Mitchell Wenger

*University of Mississippi*, [mrwenger@olemiss.edu](mailto:mrwenger@olemiss.edu)

Manoj A. Thomas

*Virginia Commonwealth University*, [mthomas@vcu.edu](mailto:mthomas@vcu.edu)

Jeffrey S. Babb Jr.

*West Texas A&M University*, [jbabb@wtamu.edu](mailto:jbabb@wtamu.edu)

Follow this and additional works at: [http://aisel.aisnet.org/amcis2011\\_submissions](http://aisel.aisnet.org/amcis2011_submissions)

---

### Recommended Citation

Wenger, Mitchell; Thomas, Manoj A.; and Babb, Jeffrey S. Jr., "An Ontological Approach to XBRL Financial Statement Reporting" (2011). *AMCIS 2011 Proceedings - All Submissions*. 448.

[http://aisel.aisnet.org/amcis2011\\_submissions/448](http://aisel.aisnet.org/amcis2011_submissions/448)

This material is brought to you by AIS Electronic Library (AISeL). It has been accepted for inclusion in AMCIS 2011 Proceedings - All Submissions by an authorized administrator of AIS Electronic Library (AISeL). For more information, please contact [elibrary@aisnet.org](mailto:elibrary@aisnet.org).

# An Ontological Approach to XBRL Financial Statement Reporting

**Mitchell Wenger**

University of Mississippi  
mrwenger@olemiss.edu

**Manoj Thomas**

Virginia Commonwealth University  
mthomas@vcu.edu

**Jeffrey S. Babb**

West Texas A&M University  
jbabb@wtamu.edu

## ABSTRACT

As a standard for the exchange, transmission, and reporting of accounting and financial data, XBRL goes a long way toward standardization. However, as the extent of contemporary financial markets is now global, XBRL reporting must transcend or accommodate differences in reporting standards. While XBRL has been of great help in standardizing the presentation of the U.S. GAAP and IASB standards, reconciling meaning between these standards is still a manual and error-prone affair. As a wide variety of stakeholders, spanning countries and cultures, will likely take part in digesting XBRL-formatted financial reports; how will they participate at an appropriate level that is meaningful for them? This paper focuses on an ontological approach towards solving this problem by offering an XBRL ontology architecture for translation between XBRL formats. The architecture is explained, evaluation criteria offered, and future research towards realizing artifacts which use this architecture are proffered.

## Keywords

XBRL, XML, Taxonomy, Ontology, GAAP.

## INTRODUCTION

Recent research in financial accounting and reporting systems has focused on eXtensible Business Reporting Language (XBRL), a subset of the eXtensible Markup Language (XML) standard, as a means of rationalizing information and meaning in business reporting. Many believe that XBRL provides broad benefits to the firms that utilize it, and that XBRL will eventually provide benefits to a larger audience of economic stakeholders both inside and outside the organization (Baldwin, 2006; Bovee, 2002; Bonson, 2009; Gray and Miller, 2009). Currently, financial reports issued by publicly-held companies around the world are relatively difficult to compare for all but the most sophisticated financial analysts. In the U.S., the Generally Accepted Accounting Principles (GAAP) provide some level of consistency across financial reports, but GAAP still allows a certain degree of flexibility in categorizing business activities within financial statements. On an international scale, accounting standards vary from country to county, which has historically made financial statements from different countries extremely difficult to compare.

The International Accounting Standards Board (IASB), known before 2000 as the International Accounting Standards Commission (IASC), has been working on a project designed to converge and standardize accounting standards worldwide. This effort has gained momentum in recent years (IASB 2003-2) as most countries' accounting standards bodies are now members of the IASB. While the U.S. Financial Accounting Standards Board (FASB) is most conspicuously absent from the IASB, the FASB has nevertheless worked and cooperated with IASB officials to define issues, highlight areas of agreement and departure, and provide general input and guidance to the overall process known at various times as global harmonization or convergence (IASB 2003-1).

XBRL International, a non-profit standards group, is the guiding organization behind development of the XBRL standards, and has launched an effort to develop taxonomies for various countries and IASB requirements (XBRL 2004-1; XBRL 2004-2). While the accounting profession and XBRL governing bodies recognize the need for financial statement comparability, there are concerns that the several relatively independent efforts presently underway towards standardization may result in a set of taxonomies that: 1) do not address the full range of financial reporting requirements, and 2) are incompatible with each other (Bovee, et al. 2002).

The purpose of this paper is to: 1) propose an ontological approach to XBRL financial reporting; 2) present a framework for building the ontologies; and, 3) introduce criteria that can be used to evaluate the success of future efforts ontologically-based reasoning efforts related to this research problem. The remainder of this paper is organized as follows. The *XBRL Taxonomy Framework* section will review the XBRL specification in greater detail, as well as current efforts to develop taxonomies covering the two major sets of accounting standards. Next, the *Ontological Approach* section will review current financial ontologies and whether they can be leveraged to enhance the taxonomy efforts. Next, the *Research Problem* section will describe the limitations of the current taxonomical approach and where this paper can address them. We next outline the solution approach where we use an ontological approach to comparative XBRL reporting in greater detail. We next present an evaluation criteria section in which we identify key factors that researchers should examine when studying this problem. Finally, conclude in a summary and discussion section which reviews the contributions and limitations of this research, as well as outline potential topics for future research.

## THE XBRL TAXONOMY FRAMEWORK

XBRL is an application and extension of XML designed specifically to be used for business reporting. As an extension of XML, it enables the exchange of data via the internet, or any other network. One big advantage that XBRL has over other technologies, such as Electronic Data Interchange (EDI), is that it affords platform independence, simplicity, and the relatively low implementation cost of XML. Despite many years of industry efforts to promote EDI, it remains a tool used mainly by the largest organizations due to the variety of proprietary, incompatible formats required by the major players, each of which is relatively expensive to integrate.

XBRL International, the consortium working on coordinating the worldwide standards for financial report presentation through XBRL, continues to develop a set of taxonomies for various reporting requirements (XBRL 2004-1; XBRL 2004-2). Each XBRL taxonomy defines a set of XML tags that identify the elements of financial reports, company profile information, auditor reports, management discussion, and other components typically included in a financial statement package.

Figure 1 shows the current international XBRL taxonomy framework. As illustrated in the figure, the taxonomy begins with a basic schema, which incorporates the actual element names (tags) used in the taxonomy. The schema references other namespaces in the discoverable taxonomy set (DTS) for guidance on the authoritative definition and accounting standards related to the element, labels to be used with the element, references to other elements in the taxonomy, calculations the element is a part of, and guidelines for presenting the element data. As the "X" in XBRL indicates, taxonomies can be extended. The US GAAP taxonomy is typically extended by individual companies for their filings, while IASB's taxonomy, based on the International Financial Reporting Standards (IFRS) can be extended at the country level before individual companies consider additional extensions.

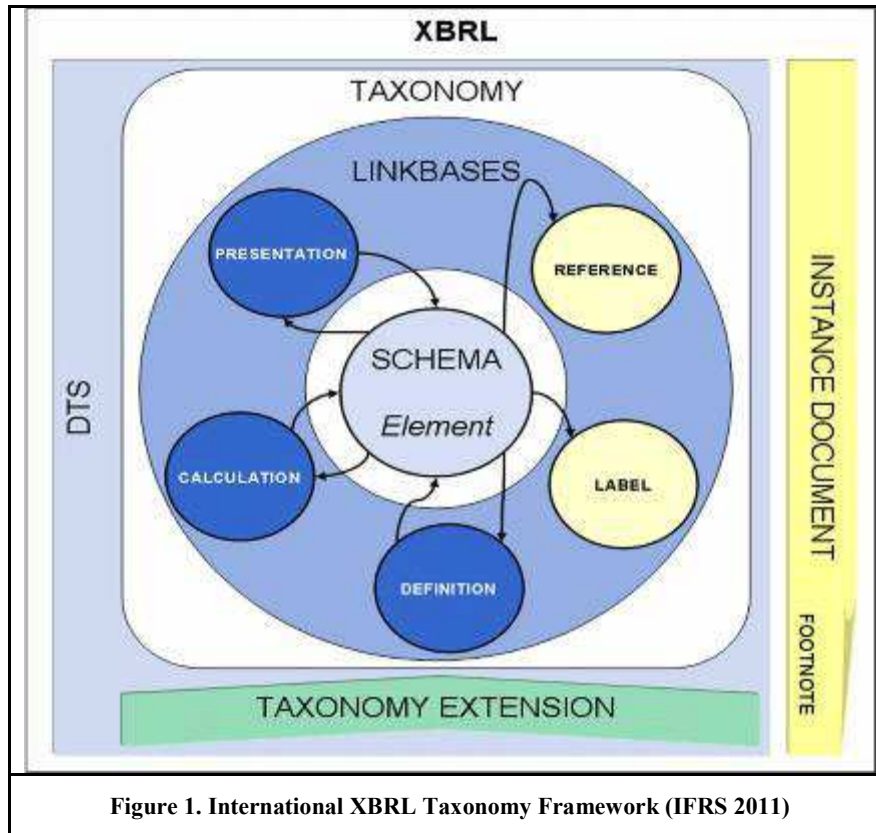
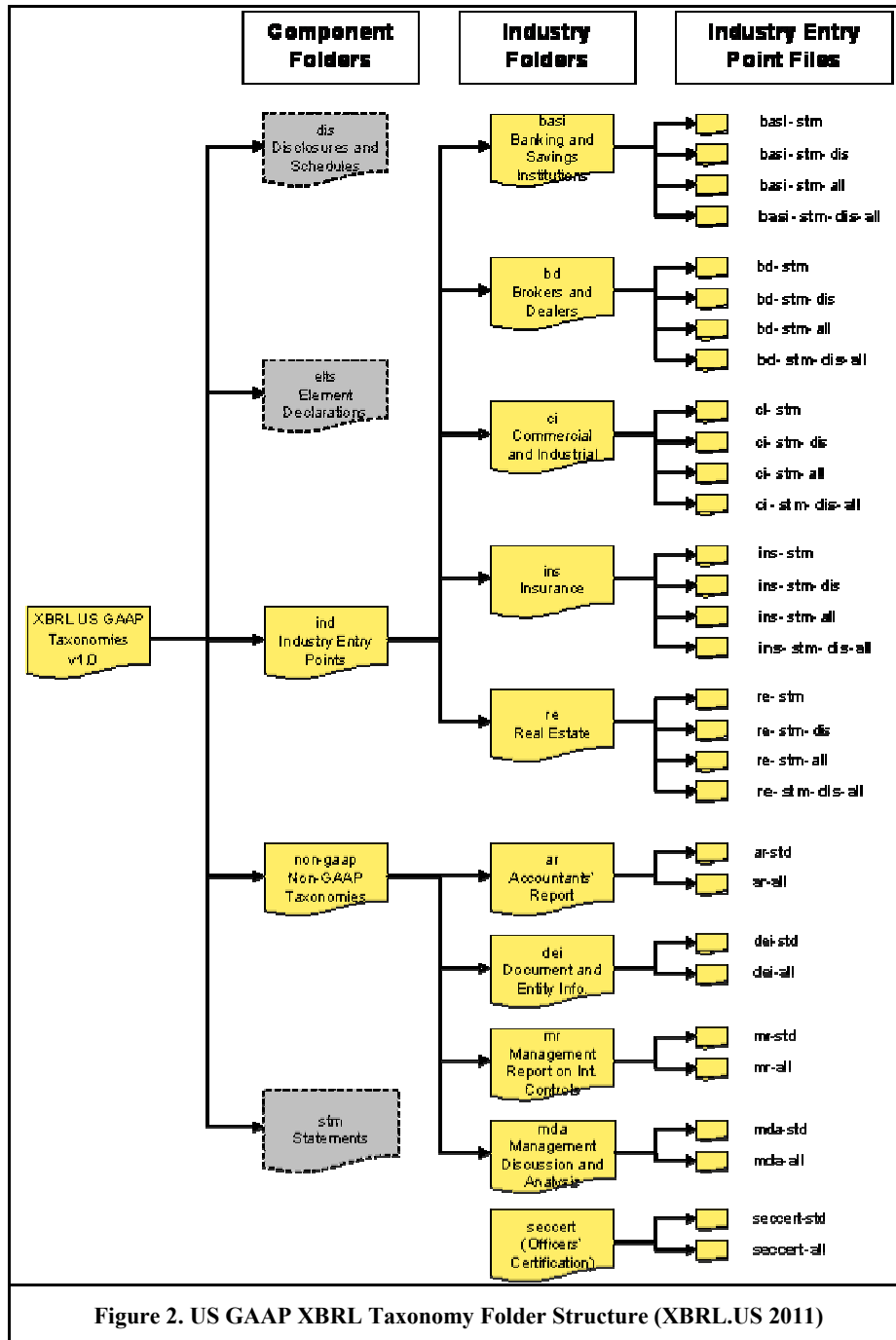

Figure 1. International XBRL Taxonomy Framework (IFRS 2011)

XBRL taxonomies can utilize a hierarchical folder structure in order to allow users to focus on the subset (or subtree) of the taxonomy relevant to a particular industry, element type, etc. Industries typically use these "entry points" as their starting location for creating XBRL instance documents. Figure 2 shows the folder structure of the current U.S. Financial Reporting Taxonomy. Most companies will use the Commercial and Industrial (ci) entry points for their instance document creation. Some industries' regulatory bodies (i.e., banking) have additional XBRL filing requirements using a predefined set of element tags. Each taxonomy entry consists of a group of XML documents which define the reference taxonomy, tag labels, presentation, calculations for reporting purposes, and definitions, plus an XML schema document. Sample instance documents are available for several of the taxonomies.



XBRL.US has just released the 2011 U.S. GAAP taxonomy for SEC approval (XBRL.US 2011). Until the taxonomy is approved, the Financial Accounting Standards Board (FASB) recommends using the 2009 taxonomy for company filings. In the 2011 U.S. GAAP taxonomy, each aspect of a company's financial report can be considered a concept. There are many concepts presented in a typical corporate filing. For example, a concept can describe a single number on an income statement, a footnote to the financial statements, or a detailed statement regarding management's statement on internal controls. Each of these concepts is "tagged" with an XBRL element. The element itself must be defined in precise detail. This is done by assigning attributes to the element. Attributes can be as basic as describing the label to use on reports, what type of data can be associated with the element, the accounting standards that define use of the element, and so on. Likewise, the element

must be defined in the scope of the overall taxonomy. This is done by defining relationships such as calculations associated with the element, where the element should be presented in various documents, and which dimensions it is a part of.

Although the XBRL specification provides a great deal of flexibility to meet individual country, industry, and company reporting requirements, this flexibility can also present some problems. Whereas each company will publish financial statements using their unique instance of the taxonomy, statement users will be limited in their review to using that company's specific taxonomy or a higher level instance in the appropriate taxonomy hierarchy. For less sophisticated statement users attempting to review financial statements from multiple countries, this could result in misunderstandings ranging from minor to disastrous. Some innocuous terminology differences may be seen as merely inconvenient, such as the use of the word "stock," which means shares of ownership in the U.S. and levels of inventory in the U.K. On the other hand, some terminology mismatches which influence values reported in financial statements could have a major impact on the bottom line. Germany, Switzerland, and Austria, for example, have historically encouraged the use of hidden reserves to help smooth earnings over multiple years. This practice provides greater income stability, which is viewed positively by the primarily creditor owners of public companies. Manual translation of financial statements from local standards to U.S. GAAP, which does not allow the use of such hidden reserves, often results in a large shift in net income and other totals from the financial statements.

As the previous examples illustrate, accounting is not necessarily an exact discipline with a completely rigid set of rules. Instead, many factors influence the ways countries implement financial statement requirements, including their political systems, their cultural and economic environments, the nature of the primary investment community, and which investment vehicles they use (Radebaugh 1975). Globalization of the world economy is a driving force for companies and countries to move toward a common set of requirements, but many obstacles remain. Despite the efforts of the IASB, it is doubtful that true harmonization of international accounting standards will happen for some time to come.

Since XBRL is still a developing standard, there are other limitations that companies will have to address. A study performed on the 2000 XBRL specification identified 866 specific shortcomings in the tag listing: 340 that would require company specific tags, 296 that were common enough to recommend adding the tags to the taxonomy, and 230 items where there was a disparity in the grouping of the item in the statement hierarchies (Bovee, et al. 2002). Much work has been done since then, but the latest U.S. GAAP taxonomies (arguably the most mature of the taxonomies to date) still show a great deal of flux. The 2009 U.S. GAAP taxonomy added more than 1,500 new elements and removed (deprecated) around 350. The 2011 taxonomy added an additional 1,900 new elements, deprecated 500, and changed the definition of around 2,200 elements (Financial Accounting Foundation, 2011). It can become a full time job keeping up with taxonomy developments for just the U.S. GAAP taxonomy, let alone trying to monitor what's going on with the IFRS taxonomy and country-specific extensions for international filers. With the flexibility of the XBRL standard, the variety of country, industry and company reporting requirements, and comparability issues, there is potential for another EDI-like situation where financial statement users will not be able to correctly interpret company documents.

## **THE ONTOLOGICAL APPROACH**

XBRL allows companies to present their financial statements in a relatively uniform electronic format. Once financial statement users receive the documents, however, they must assign their own meaning to the items in the report. In other words, each user must apply his/her personal ontology to the financial statements being reviewed. For the purposes of this research, we use ontologies to develop a way that financial statement users can interpret statements developed in different industries and countries.

Ontological research for accounting and financial systems to date has focused mainly on the transactional side of business. The Resource-Event-Agent (REA) model has been widely adopted for financial systems, and covers the broad range of activity from sales transactions to inventory movement. Ontology research on the REA model has been significant, and ISO 15944-4 implements a version of the REA ontology (Geerts and McCarthy 2002; Boyle 2003). Some ontology work has been done with respect to the accounting general ledger, but with the exception of an introductory document on automation of GAAP, this work also focuses on the transactional aspect of the financial cycle (Boyle 2003).

The XBRL taxonomy effort addresses part of the ontology for financial statement reporting. By developing common definitions, formats, and structures, a certain level of common meaning and understanding can be achieved. Unfortunately, the existence of two fundamentally different top-level taxonomies, along with the myriad of country-, industry- and company-specific taxonomies, calls for an additional level of understanding. An ontology that can provide meaning to financial statement users in a format and terms they are comfortable with will be a useful contribution to both researchers and practitioners.

## RESEARCH PROBLEM

One of Radebaugh's key factors in the development of accounting standards involves discerning from types of company stakeholders (Radebaugh 1975). In today's global economy, with multinational corporations managing operations around the world, the stakeholders in a company can be widely dispersed. The accounting profession, through U.S. GAAP and the IASB, recognizes the need to increase the utility of financial statements beyond the traditional audience of financially-savvy investors and analysts. Equity market participation is growing globally, resulting in a large number of less-sophisticated financial statement recipients. Non-financially oriented statement users may want to review environmental impact statements or employment estimates as multinationals set up operations in their towns or regions.

Another aspect of financial statement comparability is the cost companies incur when they wish to issue equities on exchanges outside their home country. Securities regulations differ from exchange to exchange, as do registration and reporting requirements. In the U.S., the Securities and Exchange Commission (SEC) used to require a reconciliation report (Form 20-F) outlining material differences between U.S. GAAP and the accounting standards used to prepare an international company's financial statements, but now allows international filers to report using IFRS. Even so, the cost of reconciliation compliance is typically the highest cost associated with listing on foreign securities exchanges (Hora, et al. 1997). A solution that can reduce the effort required by companies and analysts to convert financial results in order to meet the requirements of multiple regulatory bodies would result in significant savings.

The key research problem addressed in this paper is that the parallel taxonomies present in the current XBRL standard do not provide a way to compare financial statements across the two taxonomies. Financial statement users need a way to review financial information in a format, structure, and terms that are meaningful to them. As the target population of financial statements grows beyond professional investors and auditors, and as companies expand their operations throughout the globe, the need to present corporate information in multiple formats compatible with the requirements of this diverse stakeholder population increases. This is not to say that non-financial stakeholders do not need to invest some effort of their own in understanding basic financial statement formats for their country – they should just not be required to learn and understand all of the many formats used worldwide. At a minimum, XBRL financial reports should be transparent across IFRS and U.S. GAAP. Ideally, transparency should extend even further down the IFRS taxonomy hierarchy, providing conversion capabilities for major country groupings.

## USING AN XBRL ONTOLOGY AS A SOLUTION APPROACH

We develop an ontological approach that utilizes the shared meanings across countries and cultures could extend the taxonomy approach beyond its strict hierarchical structure, providing additional definitions of the relationships between ontology domains in a manner that would let a U.S. user view a set of German financial statements in a format consistent with U.S. GAAP and vice versa.

The XBRL organization, along with major accounting firms, and many national accounting standards organizations, is continuing the development of taxonomies and taxonomy mapping tools for implementing and testing XBRL. Although this taxonomy work is extremely important, it does not attempt to bridge the differences between taxonomies in an automated manner. The work in this paper aims to extend existing efforts by incorporating an ontological approach into the taxonomy effort in order to map financial statements across XBRL taxonomies.

The proposed solution approach to the issue of financial statement comparability and utility is an ontology-based approach to coordinating XBRL financial statements. This approach will provide benefits to a broad range of corporate stakeholders, and could result in significant restatement savings for firms implementing XBRL. The proposed ontology model is based on the knowledge map techniques discussed by Gordon (2000) and Lin and Hsueh (2003). In the knowledge map approach, the key concepts are displayed as the nodes, with relationships depicted by the lines between the nodes.

## Implementation Architecture

The knowledge map in Figure 3, which presents a high-level view of the proposed XBRL ontology, bears some similarities to the taxonomy frameworks presented earlier, and maps into ontologies for other aspects of financial systems. As with the taxonomies, there is a hierarchical arrangement to the various nodes in the map. However, the relationships between the nodes form a network of connections, which allow the specific domain ontologies to interact with each other as required. The relationships in the knowledge map define how the variations between industry and country taxonomies can be reconciled with each other.

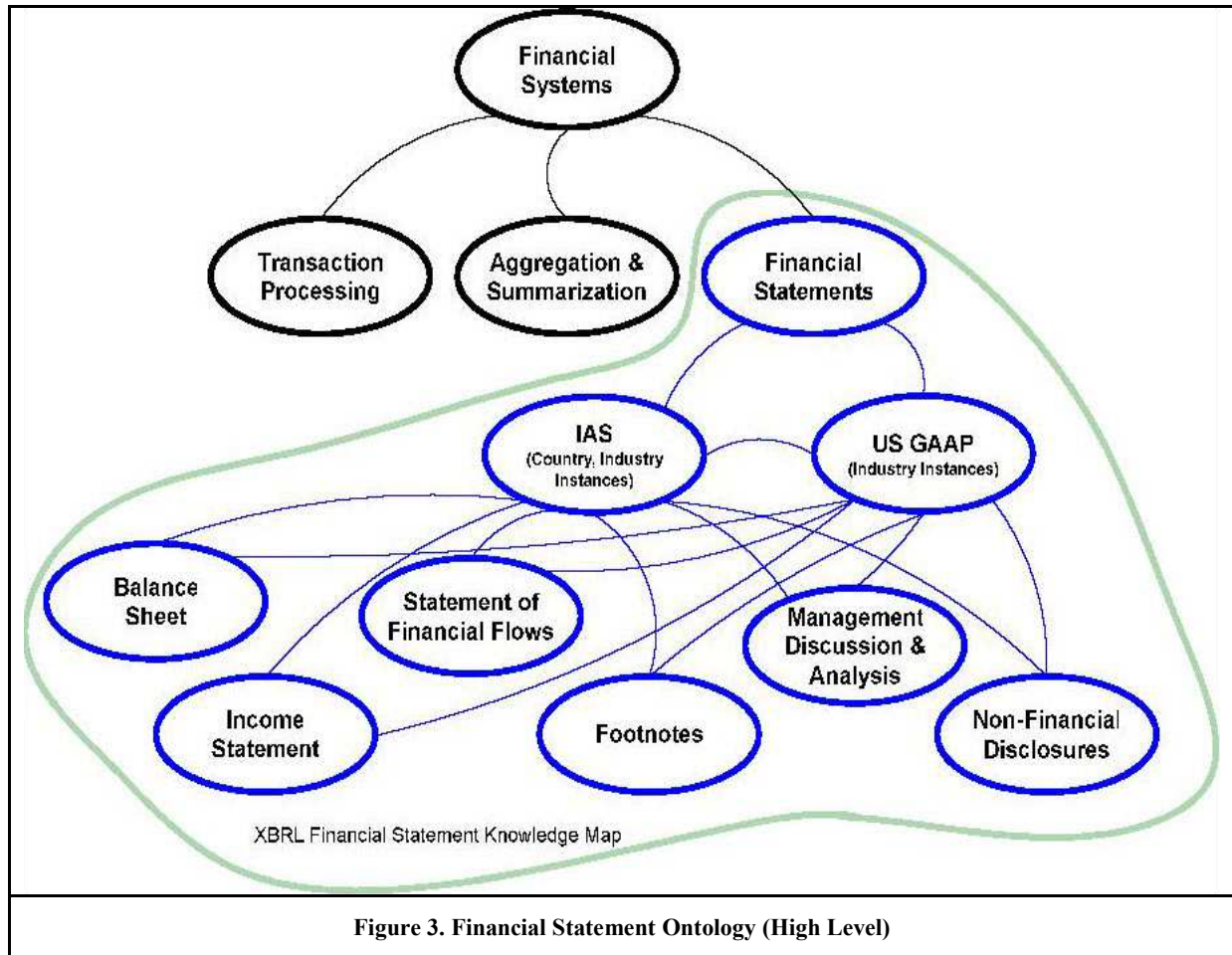

With such an approach, users requesting XBRL financial statements from companies would then have the opportunity to select their desired presentation format, which could be the originating company’s schema instance, a higher level taxonomy from the same branch of the taxonomy branch, a different branch of the hierarchy, or even a completely different taxonomy. As long as the relationships remain consistent in the XBRL ontology, users will have their choice of any available format, with appropriate warnings if the desired format is not suitable for the originating document. Figure 4 outlines the overview of this process.



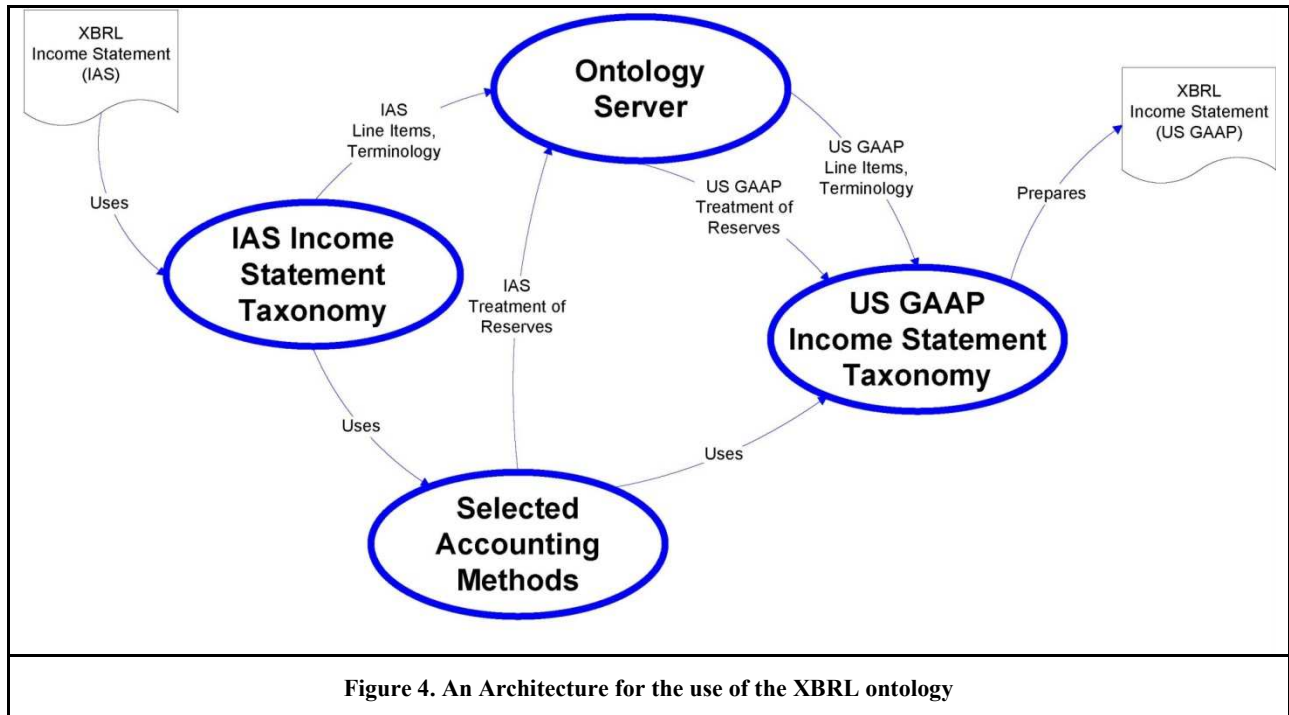

### The XBRL Ontology

The XBRL Ontology is at the heart of the implementation architecture. It has the concepts, relationships between concepts, and axioms (constraints and conditions) defined in OWL. A snapshot of the ontology in Figure 5 shows the concepts as modeled in the Protégé Ontology editor. Assuming that a user uploads an IFRS company filing via the application interface, the Input Transformation logic is responsible for loading the XBRL document into the XBRL ontology. The Input Transformation logic maps the XBRL tags to the appropriate concepts defined in the XBRL ontology.

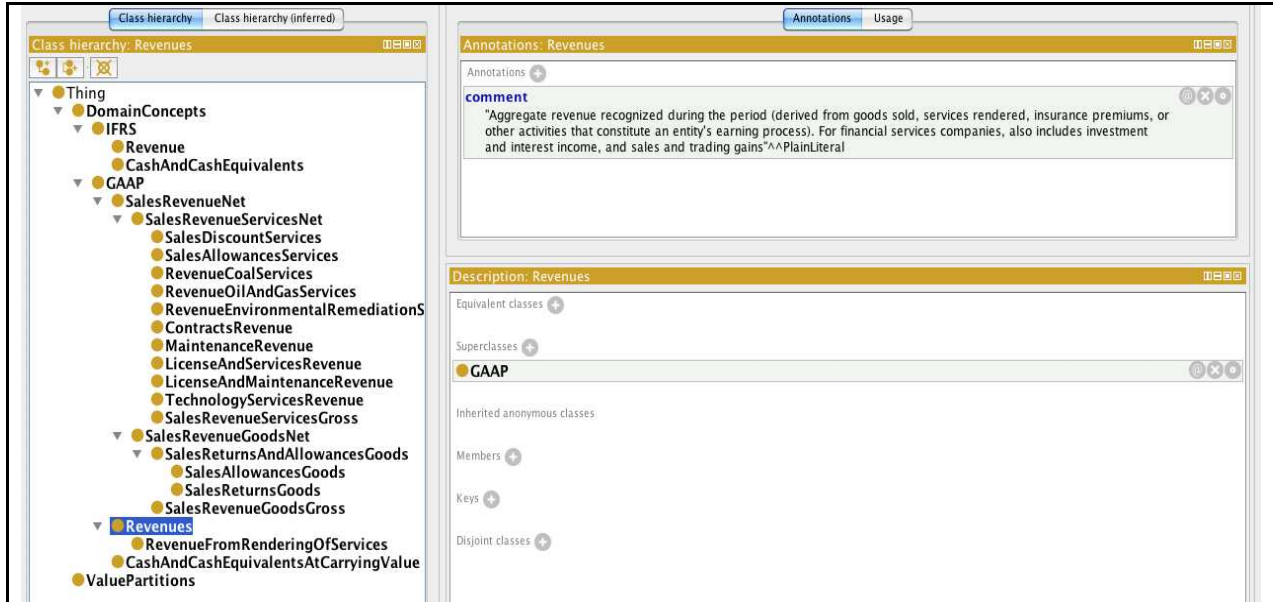

Figure 5. Snapshot of XBRL ontology in Protégé Ontology Editor

For example, the given XBRL tag in Figure 6 will be interpreted as a reference to the CashAndCashEquivalentsAtCarryingValue concept defined in the XBRL ontology. The attributes of this tag (contextRef, decimals and unitRef) correspond to ValuePartitions in the ontology. Value partitions are design patterns in ontology engineering used to refine class descriptions (Foy et al., 2001). The actual data associated with the tag (1849000000) becomes the instance of the CashAndCashEquivalentsAtCarryingValue concept. From an ontological standpoint, the taxonomy mapping process is relatively straightforward. Much of the work will merely require mapping terms and statement formats between the XBRL taxonomies and the ontology concepts. The more difficult exercise will be identifying where the differences in accounting treatment can be found in the various taxonomies, along with the calculations required for conversion between one approach and the other. Converting the textual portions of financial statements, such as the footnotes, auditor’s statement, management discussion, and other non-financial disclosures is more of a pragmatic decision on whether to attempt language translation as part of the conversion process.

```
<us-gaap:CashAndCashEquivalentsAtCarryingValue contextRef="I2008"
decimals="-6" unitRef="usd">
  1849000000
</us-gaap:CashAndCashEquivalentsAtCarryingValue>
```

Figure 6. Example XRBL Tag

Once the input transformation is complete, the reasoner is called to perform a consistency check (determine if the inferred ontology class hierarchy conflicts with the manually constructed (asserted) hierarchy) and to determine whether any new inferred instances have identified. The annotation property (Figure 5) stores descriptive or editorial information regarding a concept. Although the current version of the OWL-DL (Descriptive Logic) puts several restrictions on the usage of annotation properties, it can be used to provide meaningful, human readable information on the ontology elements (concepts, properties and instances). They can also hold valuable information regarding backward compatibility, deprecated concepts and URI references to other ontologies that may define related concepts from other financial standards.

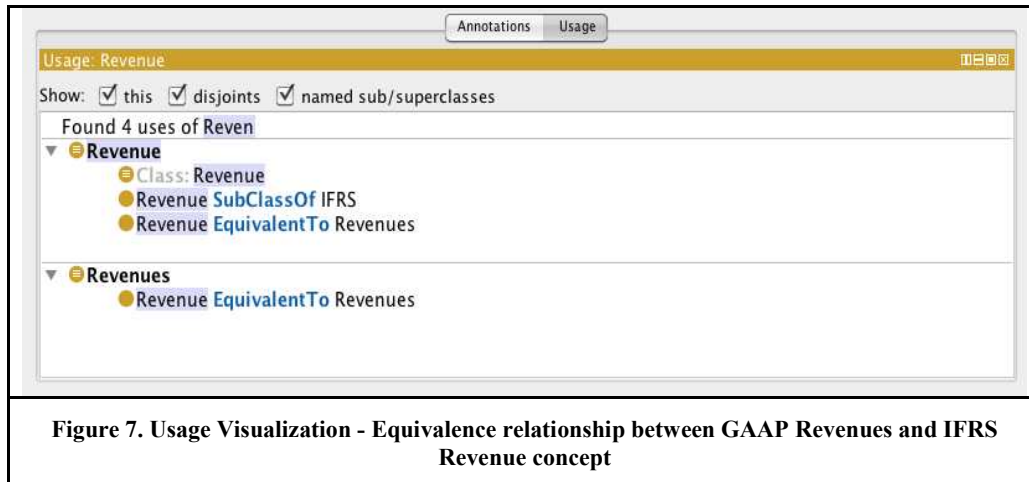

To demonstrate the architecture, consider the U.S. GAAP taxonomy concept *Revenues* which is semantically equivalent to the IFRS concept *Revenue*. These concepts are defined as equivalent classes in the XBRL ontology as shown in the 'Usage Visualization' of the OWL snippet (Figure 7). The ontology, rule base, and the instances are passed to the bridge, where JESS executes matching rules from the rule set (those for which the antecedent conditions are satisfied). Figure 8 shows the SWRL rule that will be called to reason this classification scenario. The inferred facts (outcome of JESS rule execution) are returned from the bridge to the fact base. The results are then displayed in the preferred format on the application interface by applying standard XML StyleSheet Language Transforms (XSLT).

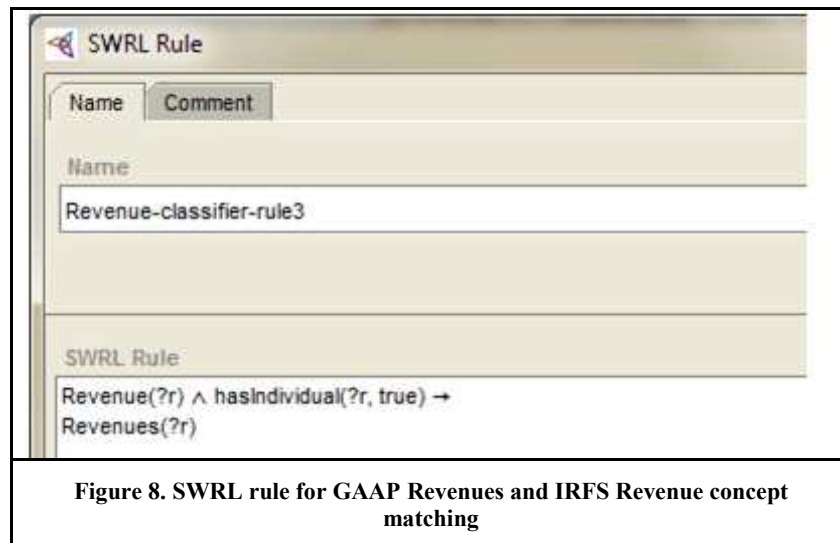

Of course, converting financial statements to different sets of accounting standards will not provide all the information a user will need. For example, even after conversion, financial ratios that are frequently used to evaluate companies, such as current ratio and short-term leverage, may differ greatly for successful companies from different countries. This is not necessarily a reflection of the financial statement conversion process, but may be a result of cultural attitudes toward corporate performance that are unique to that country. Japanese companies, for example, have historically had much higher leverage ratios than comparable U.S. companies, reflecting the Keiretsu economic structure of a conglomerate of companies tied very closely to a central bank. Large loans from the Keiretsu bank indicate a favorable outlook by the bank with respect to a company's future prospects.

## EVALUATION CRITERIA

There are three key criteria for evaluating the success of the XBRL ontology. First and foremost, does it provide a meaningful conversion of financial statements to a desired cross-section of financial statement users? To perform this evaluation, a sample (or full) ontology can be built to map the IFRS taxonomy to the U.S. GAAP taxonomy. Several international companies, reflecting a variety of conversion issues, could be converted through the ontology and presented to potential financial statement users. These users could represent financial analysts, the auditing profession, labor interests, citizens concerned about the environmental impact expanded operations may have, individual investors, and other interested parties. This evaluation would be repeated for additional ontology conversions as they are added.

Second, the XBRL ontology should be evaluated to determine the benefits, if any, of using it. Providing useful information to an expanded set of financial statement users seems like a worthy objective, but does the ontological approach provide substantive benefits? If so, are they deemed important enough to continue the efforts? Do users get the information they need from the ontologically converted statements, or do they need to refer back to the originating statements to supplement their analysis. Do securities exchanges accept converted statements for listing and reporting purposes, or will companies have to perform additional work to maintain their exchange eligibility?

The third criterion for evaluating the XBRL ontology is its maintainability. Is the XBRL ontology a cost-effective exercise, and is it easy to maintain as standards are updated? An ontology that provides limited benefits at great cost would hardly be worth maintaining. Should the ontology effort pass the first two evaluation criteria, the increase/decrease in the volume of requests will provide a rough benchmark of the perceived utility of the approach.

## FUTURE RESEARCH

From a practical standpoint, the XBRL ontology relationships will begin with U.S. GAAP to IFRS mapping, and probably will extend only to the country/industry level, or possibly to a country group level for countries with similar taxonomies. Since all company instances will map to one of the country/industry combinations, this level will provide transparency at a reasonable level of comparability, without the resource requirements of maintaining relationships for each company listed. As standards are enforced to include XBRL tagging for the footnotes, our XBRL ontology model has to be revised to address the requisite changes. When the elements in the US GAAP or IFRS taxonomies change, evolve, and deprecate, how will the ontology also evolve? Is this a manual process? These are the questions that future research, empirical work, and design science activities should investigate.

## CONCLUSION

This research has presented an ontology-based approach to developing XBRL definitions for financial statement preparation. This approach shows promise for providing significant benefits in two ways: 1) by increasing the utility of financial statements to a broader range of firm stakeholders, and 2) by reducing the cost of restatement compliance for companies listing on multiple country exchanges.

This paper has been limited to a conceptual discussion of the solution and presentation of the ontology knowledge map at a very high level. Future research opportunities include further development of the knowledge map to at least the country/industry level of detail. In addition, the researcher could create and test a pilot ontology covering a subset of taxonomies and XBRL document types, which could then be evaluated through an experimental test of stakeholders reviewing financial statements from different points in the ontology to determine whether the statement information is passed across ontology domains in an effective manner. With the XBRL standard still evolving and expanding to additional countries, the opportunities for future research along these lines should continue for quite some time.

From another perspective, research into the feasibility of a learning ontology could be interesting. If the ontology can be populated down to a certain level with various financial statement nodes and relationships, would it be feasible to apply knowledge concepts to the ontology such that it can build its own relationships as companies add/modify their instances?

## REFERENCES

1. Baldwin, A.A. (2006). XBRL: An Impacts Framework and Research Challenge, *Journal of Emerging Technologies in Accounting*, 3, 97-116.
2. Bonson, E. (2009). Towards the global adoption of XBRL using International Financial Reporting Standards (IFRS). *International Journal of Accounting Information Systems* 10, 46.
3. Bovee, M. et al. (2002). Does the year 2000 XBRL taxonomy accommodate current business financial-reporting practice? *Journal of Information Systems*, 16, 2, 165-182.

4. Boyle, T. (2003). Ledger Ontology (draft). Kirkland, Washington, USA. Ledgerism. 2004: <http://ledgerism.net/LedgerOntology.htm> (accessed Feb. 2011)
5. Clements, B., Schwieger, D., & Surendran, K. (2010). Development of an Evaluation Model for XBRL-enabled Tools Intended for Investors. *Conference on Information Systems Applied Research vol. 3*. Nashville Tennessee, USA
6. Debreceeny, R., & Gray, G.L. (2001). The production and use of semantically rich accounting reports on the Internet: XML and XBRL. *International Journal of Accounting Information Systems* 2, 47-74.
7. Financial Accounting Foundation (2011). U.S. GAAP Financial Reporting Taxonomy Now Available. vol. 2011. Norwalk, CT: Financial Accounting Foundation.
8. Geerts, G. L. and W. E. McCarthy (2002). An ontological analysis of the economic primitives of the extended-REA enterprise information architecture. *International Journal of Accounting Information Systems* 3, 1, 1-16.
9. Gordon, J. L. (2000). Creating knowledge maps by exploiting dependent relationships. *Knowledge-Based Systems* 13, 2-3, 71-79.
10. Gray, G.L., & Miller, D.W. (2009). XBRL: Solving real-world problems. *International Journal of Disclosure & Governance*, 6, 207-223.
11. Gruber, T. R. (1993). A translation approach to portable ontology specifications. *Knowledge Acquisition* 5, 2, 199-220.
12. Hora, J. A., R. H. Tondkar, et al. (1997). International accounting standards in capital markets. *Journal of International Accounting, Auditing and Taxation* 6, 2, 171-190.
13. Horrocks, I., Patel-Schneider, P. F., Boley, H., Tabet, S., Grosz, B. and Dean, M. (2003). SWRL: A Semantic Web Rule Language Combining OWL and RuleML. <http://www.daml.org/2003/11/swrl/> (accessed Feb. 2011)
14. Horrocks, I., Sattler, U. and Tobies, S. (2000). Practical Reasoning for Very Expressive Description Logics, *Logic Journal of the IGPL*, 8, 3, 239-264.
15. IASB (2003-1). International Accounting Standards Board Welcomes US Move To Converge With IFRSs, International Accounting Standards Board. 2004: [http://www.iasb.org/news/press.asp?showPageContent=no&xml=10\\_19\\_30\\_15122003.htm](http://www.iasb.org/news/press.asp?showPageContent=no&xml=10_19_30_15122003.htm) (accessed Feb. 2011)
16. IASB (2003-2). International Accounting Standards Board Issues Wide-Ranging Improvements to Standards, International Accounting Standards Board. 2004: [http://www.iasb.org/news/press.asp?showPageContent=no&xml=10\\_33\\_30\\_18122003.htm](http://www.iasb.org/news/press.asp?showPageContent=no&xml=10_33_30_18122003.htm). (accessed Feb. 2011)
17. IFRS (2011). XBRL Taxonomy Framework. *xbrl\_fundamentals.gif*. London, International Financial Reporting Standards Foundation: <http://www.ifrs.org/XBRL/Resources/Fundamentals.htm>.
18. Kaplan, D., et al. (1998). Assessing data quality in accounting information systems, *Communications of the ACM*, 41, 2, 72-78
19. Lara, R., Cantador, I., & Castells, P. (2006). XBRL Taxonomies and OWL Ontologies for Investment Funds. *1st International Workshop on Ontologizing Industrial Standards at the 25th International Conference on Conceptual Modeling (ER2006)*. Tucson, Arizona, USA, pp. 14.
20. Lin, F. and Hsueh, C. (2003). Knowledge Map Creation and Maintenance for Virtual Communities of Practice. *Proceedings of the 36th Hawaii International Conference on System Sciences (HICSS-36 2003)*, January 6-9, 2003, Big Island, pp. 69a.
21. O'Connor, M., H. Knublauch, T. Samson, B. Grosz, M. Dean, W. Grosso, and M. Musen, (2005), Supporting Rule System Interoperability on the Semantic Web with SWRL, *Lecture Notes in Computer Science*, Springer Berlin/Heidelberg, 974-986.
22. Pinsker, R., & Wheeler, P. (2009). Nonprofessional investors' perceptions of the efficiency and effectiveness of XBRL-enabled financial statement analysis and of firms providing XBRL-formatted information. *International Journal of Disclosure & Governance*, 6, 241-261.
23. Porter, N., Ed. (1998). Webster's Revised Unabridged Dictionary. Springfield, Massachusetts, USA, C. & G. Merriam Co.
24. Peuschel, B. and Schafer, W (1992). Concepts and Implementation of a Rule-Based Process Engine, *Proceedings of the 14th International Conference on Software Engineering*, 262-279.
25. Radebaugh, L. H. (1975). Major factors influencing the development of accounting objectives, standards and practices domestically and worldwide, *International Journal of Accounting Education and Research*: 41.
26. Spies, M. (2010). An ontology modeling perspective on business reporting, *Information Systems*, 35, 404-416.
27. Taylor, E.Z., & Dzurainin, A.C. (2010). Interactive Financial Reporting: An Introduction to eXtensible Business Reporting Language (XBRL), *Issues in Accounting Education*, 25, 71-83.
28. Tribunella, T., & Tribunella, H. (2010). Using XBRL to Analyze Financial Statements, *CPA Journal* 80, 69-72.
29. XBRL (2004-1). International Taxonomies Under Development. New York, XBRL International. 2004: <http://www.xbrl.org/resourcecenter/inttaxonomy.asp?sid=22>.

30. XBRL (2004-2). US Financial Reporting Taxonomy Framework. New York, XBRL International. 2004: <http://www.xbrl.org/Taxonomy/us/TaxonomyFrameworkOverview.htm>
31. XBRL (2004-3). International Accounting Standards Expressed in XBRL for Electronic Financial Reporting. New York, XBRL International. 2004: <http://www.xbrl.org/taxonomy/int/fr/ias/>
32. XBRL.US (2011). IFRS (2011). Understanding and Using Taxonomies. Washington, DC. XBRL US, Inc.: <http://xbrl.us/preparersguide/Pages/Section3.aspx>.