

Association for Information Systems AIS Electronic Library (AISeL)

Wirtschaftsinformatik Proceedings 2009

Wirtschaftsinformatik

2009

TOWARDS CROSS-ORGANISATIONAL E- GOVERNMENT: AN INTEGRATED APPROACH

Stephan Streit

University of Applied Sciences St. Gallen

Uwe Heck

University of Applied Sciences St. Gallen

Ulrich Reimer

University of Applied Sciences St. Gallen

Christoph Schroth

University of St. Gallen

Till Janner

University of St. Gallen

See next page for additional authors

Follow this and additional works at: <http://aisel.aisnet.org/wi2009>

Recommended Citation

Streit, Stephan; Heck, Uwe; Reimer, Ulrich; Schroth, Christoph; Janner, Till; Collm, Alexandra; Hristova, Ralitsa; and Ritsch, Roland, "TOWARDS CROSS-ORGANISATIONAL E-GOVERNMENT: AN INTEGRATED APPROACH" (2009). *Wirtschaftsinformatik Proceedings 2009*. 133.

<http://aisel.aisnet.org/wi2009/133>

This material is brought to you by the Wirtschaftsinformatik at AIS Electronic Library (AISeL). It has been accepted for inclusion in Wirtschaftsinformatik Proceedings 2009 by an authorized administrator of AIS Electronic Library (AISeL). For more information, please contact elibrary@aisnet.org.

Authors

Stephan Streit, Uwe Heck, Ulrich Reimer, Christoph Schroth, Till Janner, Alexandra Collm, Ralitsa Hristova, and Roland Ritsch

TOWARDS CROSS-ORGANISATIONAL E-GOVERNMENT: AN INTEGRATED APPROACH

Stephan Streit, Uwe Heck, Ulrich Reimer¹,
Christoph Schroth, Till Janner², Alexandra Collm,
Ralitsa Hristova³, Roland Ritsch¹

Abstract

One of the most challenging issues in current e-Government initiatives is the seamless exchange of information and the efficient collaboration between public administrations, companies and the private sector. Either from an intra- or cross-organisational point of view spanning processes across multiple authorities leads to a collaboration of autonomous units under consideration of law and regulations. Despite the organisational dimension current approaches are mainly technical solutions – e.g. interoperability frameworks. Within this paper we present an integrated approach which incorporates organisational aspects of the public sector and which supports the correspondent implementation of solutions for cross-organisational e-Government by adopting Model-Driven-Development practices.

1. Introduction

The term electronic government (e-Government) arose at the beginning of the 1990s and describes approaches to achieve greater operational efficiency and improved customer-oriented services in the public sector. Meanwhile many European countries have activities in the field of e-Government primarily in response to public expectations with efficiency gains in mind [14]. Therefore such programmes are designed to reduce government costs, improve delivery of public services, increase engagement of citizens in public matters or to achieve better outcomes in major policy areas like taxation and others [4].

While the online provision of portal-based information services have been managed by most European countries without difficulties [4], complete electronic services at the transactional stage are challenging because of their complexity. They are typically cross-organisational, require the collaboration of several stakeholders, and include business processes and information systems that are owned by the different stakeholders. All these aspects have to be integrated into an entire end-to-end cross-organisational process of service provision. With the development of such

¹ University of Applied Sciences St. Gallen, Institute for Information and Process Management CH-9000 St. Gallen, Switzerland

² University of St. Gallen, Institute for Media and Communication Management, CH-9000 St. Gallen, Switzerland

³ University of St. Gallen, Institute for Public Services and Tourism, CH-9000 St. Gallen, Switzerland

e-Government, an increasing number of governments around the world are trying to define approaches suitable for the re-engineering of their information systems and underlying business processes. Therefore solutions for cross-organisational e-Government that involve many autonomous interaction partners are especially promoted by the EU. It presupposes the possibility for complete electronic service delivery [10], [11], [13]. Hence, on the EU level there are already several attempts to realize cross-organisational e-Government [4]. The need for cross-organisational e-Government was also the initial point of the HERA (Helvetic e-Government Reference Architecture) research project⁴) which started in 2007 with the aim of:

- providing a seamless integration of intra-/ cross-organisational e-Government processes into a comprehensive end-to-end process,
- sharing information between process participants while ensuring that the involved parties only see exactly those pieces of information they are qualified to see,
- reducing the effort required to implement and maintain cross-organisational e-Government applications by adopting a model-driven approach.

In the following sections we describe the main results from the HERA project, which we propose as integrated approach to cross-organisational e-Government. First we present the application scenario to outline the motivation of our work. Afterwards we elaborate our integrated approach in chapter 3 and briefly discuss the resulting HERA platform and the correspondent architecture.

2. Motivation and Application Scenario

Moving towards the transactional stage of e-Government often requires processes that span across multiple authorities. Especially in a federated environment like Switzerland, those authorities are autonomous. This results in a fair amount of collaboration to deliver comprehensive services based on law and regulations. Such processes are triggered by some initiating event, e.g. customer inquiry and each authority contributes to the service delivery.

As an example of such cross-organisational process we focus in the HERA project on the declaration of company taxes on profits. The initiating event stems from a company or a trustee which prepares the annual financial statements, then involves an auditor and finally one or more tax offices, depending on the set of subsidiaries in the different cantons. Numerous workshops with the parties involved in the tax declaration process were conducted, including the tax offices of three Swiss cantons. The resulting analysis showed the following main characteristics of the process:

- The process is clearly divided into different (cross-organisational) sub-processes, each with a different person being responsible and different persons, resp. organisations being involved.
- The interaction amongst cross-organisational sub-processes is mainly well structured.
- The transition from one sub-process to the next implies a media break because all relevant documents are transferred into paper format. Although within the sub-processes they are commonly handled electronically.
- The process duration can be quite long (longer than one year), causing a lack of transparency with respect to the process status, its history, current responsibilities and tasks.

⁴ HERA is funded by the CTI Swiss Confederation innovation promotion agency under grant number 8617.1. The project comprises the following partners: University of Applied Sciences St. Gallen, Institute IPM; University St. Gallen, Institute MCM; University St. Gallen, Institute IDT; Abraxas Informatik AG; Abacus Research AG; BOC Information Systems GmbH; OBT AG; Finanzdirektion Kanton Schwyz; Finanzdirektion Kanton St. Gallen; Kantonale Steuerverwaltung Thurgau. For further information see <http://www.hera-project.ch>

- Sub-processes are goal-driven and therefore do not follow a fixed workflow.
- Interaction within a certain sub-process tends to be collaboration between multiple autonomous authorities.

From our experience we assume that such a characterisation applies to many more e-Government processes, namely to any cross-organisational process that includes knowledge-intensive tasks and thus involves collaboration activities between process participants. Our assumption is corroborated by similar findings mentioned in [3], [5], [7]. Cajander et al [3] argued that imposing a rigid structure on e-Government processes will result “in IT systems that do not support the situated nature of work”. Consequently, a pure workflow approach is not sufficient to support the tax declaration process in a satisfactory way.

In particular, existing approaches to cross-organisational e-Government which are either based on a workflow paradigm [1], [13] or employ an automatically orchestrated interplay of services without any human interaction [8] cannot support such processes adequately. It therefore was decided to establish an approach that supports the characteristic of these cross-organisational e-Government processes and to develop a correspondent platform that can be applied to such processes. Before we further describe our approach in detail, we shortly discuss the HERA platform and its foreseen use as basis for the process company tax declaration process.

As shown in Figure 1 the HERA platform guides a participant through the sub-processes and supports the collaboration between process participants. Such collaborations are typically document-oriented. HERA provides all the required services like scheduling, plausibility checks and monitoring in order to track the process and to control the several sub-processes. Also HERA offers a rule component to ensure domain-specific constraints e.g. laws are followed. For example, the tax declaration has to be checked for completeness and consistency by a tax accountant before it can be sent to the tax authority. A participant can access HERA via a dedicated HERA adapter (see section 3.3). Such an adapter can either be used by a web client or a legacy system.

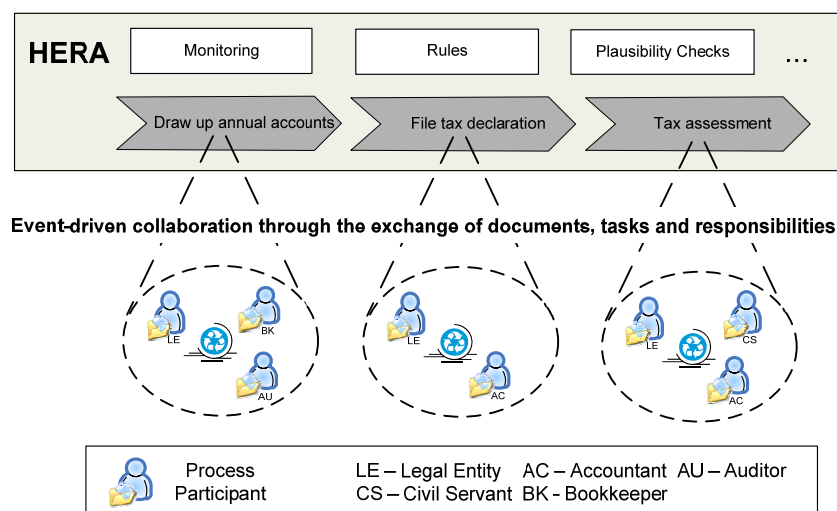

Figure 1: The HERA platform for supporting the process of tax declaration for companies

The platform offers the following benefits for the tax declaration process:

- *Process transparency*: Process participants are always informed of the current process status. E.g. a participant can check if a request for an adjust posting is pending.
- *Faster communication*: Due to the avoidance of media breaks and the instantaneous sending of documents process duration becomes much shorter. E.g. the annual statements can be submitted in an electronic format straight into the IT-System of the tax advisor.
- *Complete records files*: All the documents involved in the process are in an electronic format so that the completeness of a records file is always guaranteed (as opposed to a paper file). E.g. plausibility and completeness checks are executed during the submission of the tax declaration to the tax department.
- *Correct processes*: Underlying business rules ensure (to a certain degree) a correct process. For example, incomplete or wrongly filled-in tax declaration forms cannot be submitted.
- *Reduced manual effort and elimination of errors*: The filled in fields of the tax declaration form can be automatically transferred to the tax assessment system. This reduces the manual intervention needed and eliminates the possibility of errors.
- *Eliminating duplicate efforts*: Supporting all aspects of the tax declaration process within one process and one system (such as requests for deadline extension, requests for additional documents, declaration of withholding tax) eliminates otherwise occurring duplicate efforts.
- *Integration with related e-Government processes*: By accommodating an arbitrary number of e-Government processes on one or a set of federated HERA platforms, the benefits multiply (such as combining corporate tax declaration with value-added tax declaration, the registration of addresses, etc.).

We claim that these benefits can be achieved for similar cross-organisational e-Government processes that are implemented by using our approach and platform.

3. An integrated approach for cross-organisational e-Government Processes

3.1 Supporting collaborative sub-processes through patterns of interaction

HERA provides an integrative support for cross-organisational e-Government processes that follow a certain workflow and are being collaborative within each sub-process, like the envisaged tax declaration process. In order to support collaboration and to provide the means to keep track of what is or what was going on, and – most importantly – which task has to be done, we introduce *interaction patterns* as elementary building blocks for collaboration. Such patterns support our aim to adopt model-driven development practices (see section 3.2). An *interaction pattern* (Figure 2) is a template for collaborative actions with similar characteristics that is (re-)used within several sub-processes – e.g. the pattern RequestInformation can be applied to realize actions like request invoice or request adjusting entry.

Tax process Example	Collaborative action	Derived Pattern (Name & Description)
Revisor sends the annual statement to tax office in St. Gallen.	SendFiscalDataForValidation	<i>SendInformationForProcessing</i> Information is sent along with the process ownership from the sender to the receiver. The sub-process then ends for the sender.
Tax advisor sends tax declaration to the tax office.	SendTaxDeclarationForSubmission	
Accountant A requests an adjustment from Accountant B during the creation of the annual statements.	RequestAdjustmentPosting	<i>RequestInformation</i> An information query is sent to a receiver. The receiver may pass on the request to another participant or must send the requested information back to the sender. Pending requests may be deleted by the sender.
Accountant requests preliminary annual balance sheet from the revisor.	RequestAnnualBalanceSheet	

Figure 2: Examples of interaction patterns

The interaction patterns can be extended with additional Quality-of-Service (QoS) characteristics, like maximum response time or level of encryption.

3.2 Generating correspondent applications through a model-driven approach

In order to provide an integrated solution that supports a broad range of similar processes like the tax declaration process we adopt model-driven development (MDD-)practices [9], [12] within in our approach. This fits our aim to support similar cross-organisational processes. By adopting MDD we therefore have to set up meta models for processes, organisational aspects and data. From such meta models we derive models from which application-specific components for the envisaged HERA platform (see section 3.3) are generated (Figure 3).

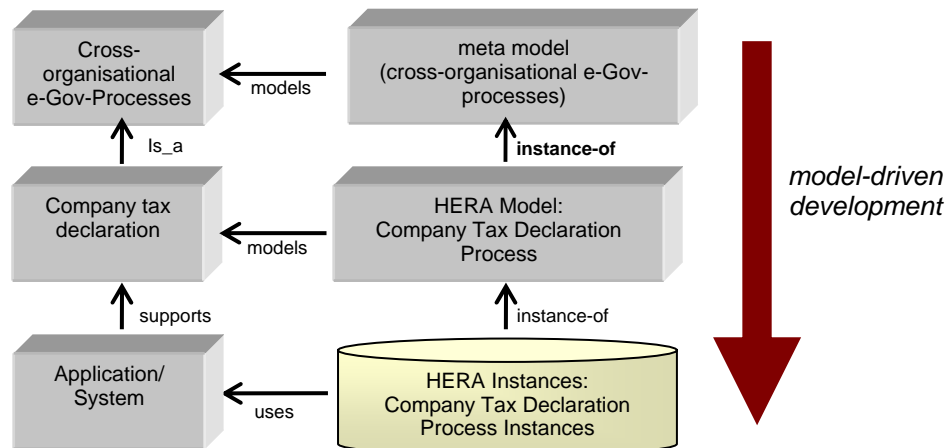

Figure 3: HERA: Model-driven-development used for cross-organisational e-Government Processes

To further illustrate how we use MDD-Practices within our approach we briefly introduce our Meta-Models for processes and organisational aspects (Figure 4) and their corresponding models for the Tax Declaration Process (Figure 5). These models serve as the basis for the model-driven development process delivering components for the HERA platform.

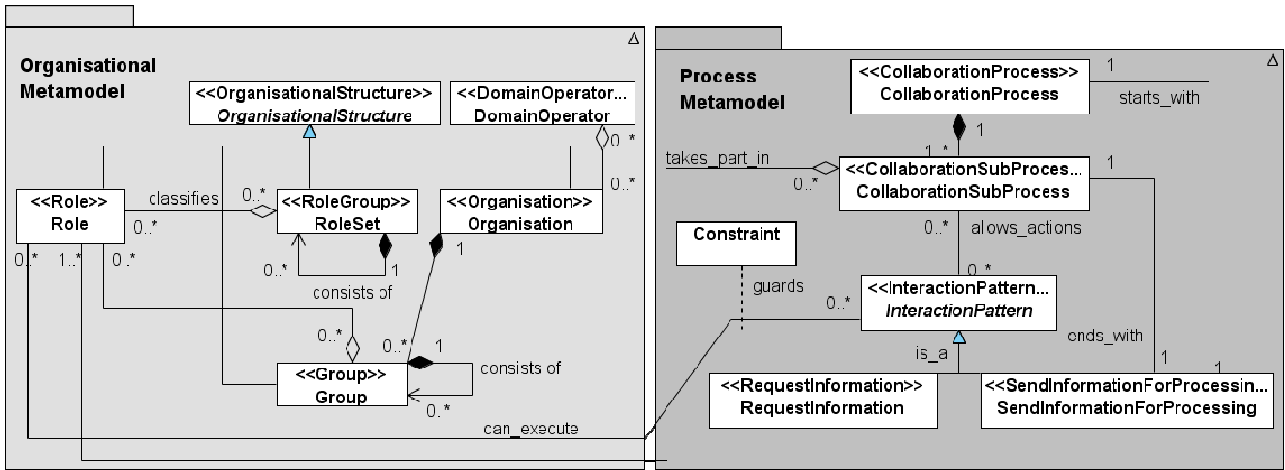

Figure 4: Meta-Models for processes and organisational aspects

The following Figure 5 shows how we apply these meta models to the tax declaration process.

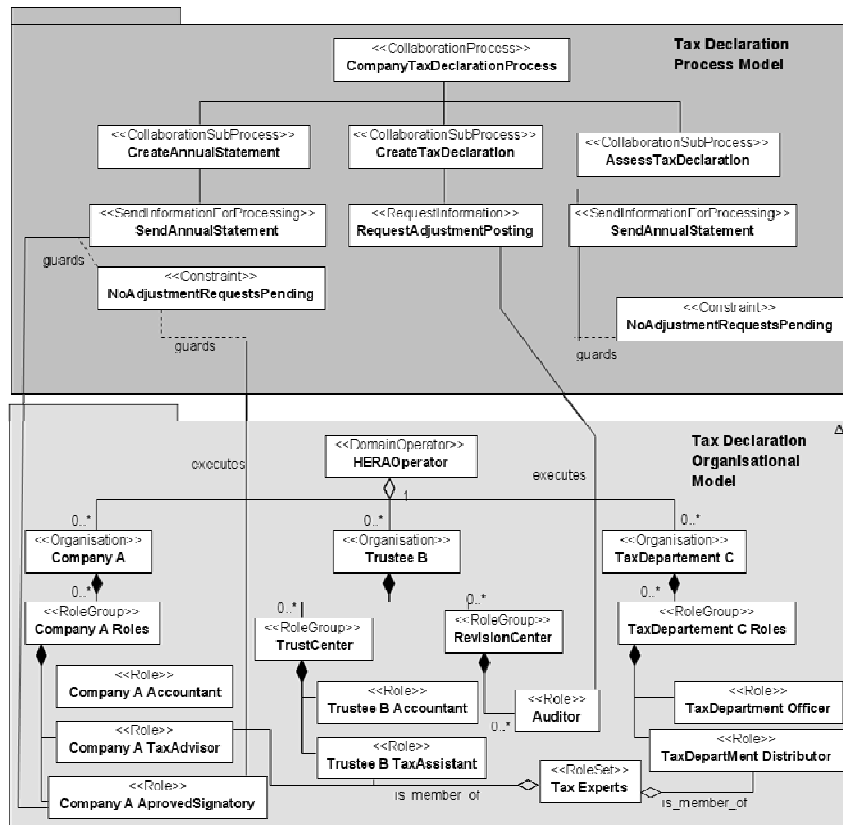

Figure 5: Model-Instances of the Meta-Model for the tax declaration process

As mentioned above these models are used in the model-driven development process to generate components for the HERA platform, which is described in the following section.

3.3 Providing a modular and flexible platform

In order to provide a flexible platform for implementing the above described cross-organisational processes we provide a common, standards-based infrastructure that leverages best practices from

service-oriented and event-driven architectures. It will be briefly outlined in the following paragraph, both from an organisational and a technical point of view. The following approach has been chosen to cope with the organisational requirements:

The sub-processes (“draw up annual accounts”, “file tax declaration”, “tax assessment”) have been mapped to *Interaction Modules* [15], [15a] in an architectural sense. Each Interaction Module represents a clearly defined sphere of agents (participants) who interact with each other by exchanging certain information objects (which we refer to as events) and thereby follow a specific structural organisation (participating roles, their respective rights and obligations with respect to their interaction, which we also refer to as contract structure) as well as process-oriented organisation (the temporal interdependencies between executable interaction patterns, which we also refer to as task structure).

Depending on factors such as legislation (varies from canton to canton) and individual business preference, these Interaction Modules may differ from each other: The Interaction Module “file tax declaration” applied in the canton of Zürich, for example, may require the exchange of different events than the one applied in Thurgau.

In order to realize these mutually independent yet interoperable interaction modules, the HERA platform (HERA bus) [15] has been developed which extends the recent Swiss governmental initiative “Event Bus Switzerland (EBS)” [6] (Figure 6): First, in order to physically realize the interaction of agents, a bus medium has been proposed which features a set of operational services: Abonnement services (supporting Publish/subscribe message dissemination), directory services (allowing for publishing and retrieving business partners and their respective profiles), event catalogue services (documenting all messages which may be disseminated via the bus including the agent roles which may send/receive them), transformation services (accounting for mediation of electronic artefacts which adhere to different format standards), security services (encryption and decryption), operating services (for media administration purposes), error services (automatic failure detection and removal), routing services, and validation services (e.g., for evaluation of correctness and integrity of exchanged information).

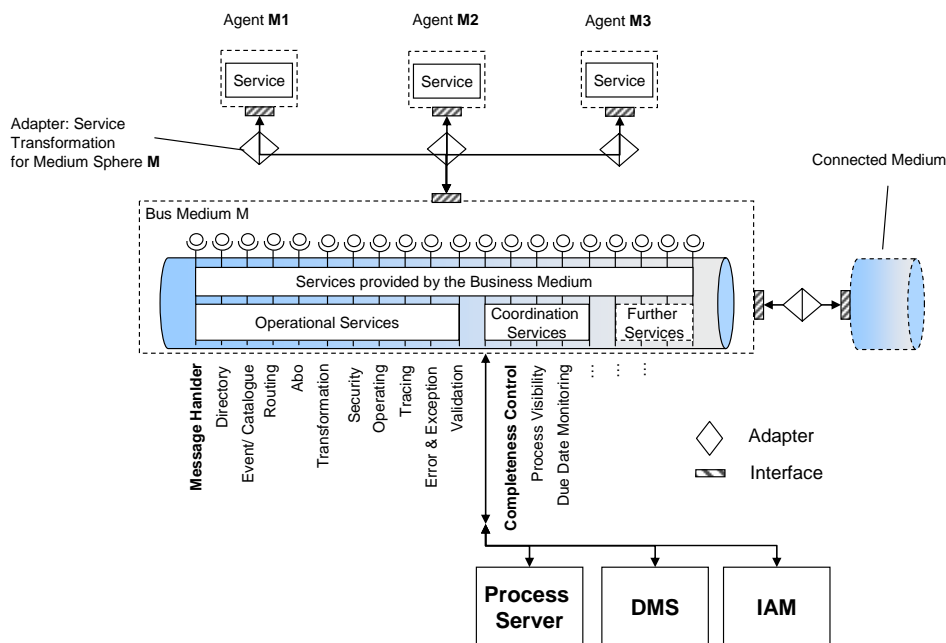

Figure 6: HERA Bus: Modular Interaction Enabler Providing Connectivity [15]

Agents are connected to this HERA bus via clearly defined interfaces describing the events they are authorized to send and to receive. In case an agent adheres to design rules varying from the one established within the HERA bus, adapter modules are required [17a]. Within the HERA bus, additional coordination services (e.g., completeness control, process visibility and due date monitoring) have been deployed which do not only enable reliable message transport but also interpret and react upon message content. In addition, a Process Server service, a Document Management System (DMS) service as well as an Identity & Access Management (IAM) service have been deployed. The process server service stores the structural and process-oriented organisation for each of the interaction modules. In other words, it orchestrates the document-based interaction between the agents according to the business logic which has been generated with the help of the model-driven approach presented above.

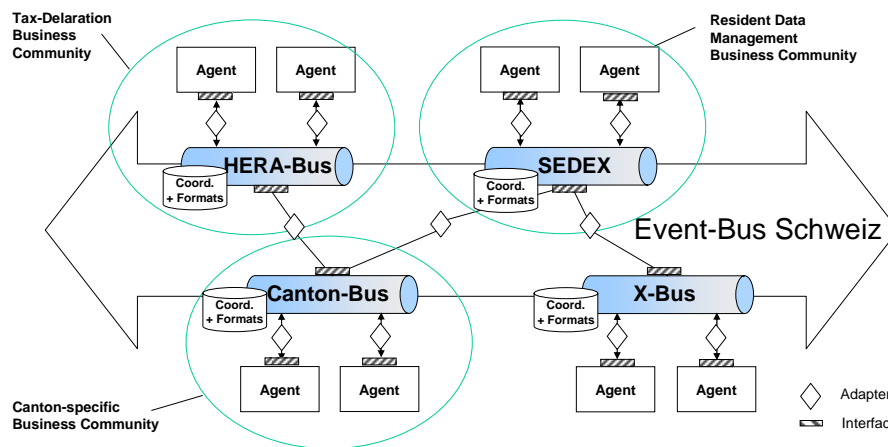

Figure 7: Interoperability across several domains through compliance with Event-Bus Schweiz [6]

As already indicated in Figure 6, our HERA platform does not only foresee agile interoperability within the sphere of one “business community” and its business medium, but also allows for loosely coupling of several buses which again may connect diverse agents. For cross-medium interoperability, each bus can incorporate an individual service design as long as it adheres to minimal “global design rules” which require the implementation of a standardized directory service, an event-catalogue service and the conformance to a specific message envelope standard [6].

On this basis, events can be seamlessly exchanged between agents connected to different bus media. Figure 7 shows part of the emerging e-Government landscape in Switzerland which comprises a set of mutually independent, but seamlessly interoperable electronic media. The SEDEX bus, for example, has been designed to serve governmental institutions which perform resident management specific tasks [2]. Through complying with a set of global design rules (the EBS specification), agents connected to the SEDEX bus can also interoperate and exchange messages with agents connected to our HERA bus.

4. Conclusions

Cross-organisational e-Government processes typically span across multiple authorities. Especially in a federated environment like Switzerland, those authorities are autonomous. This results in a fair amount of collaboration to deliver comprehensive services based on law and regulations. As an example of such a cross-organisational process we focus in our research on the tax declaration of companies as an example.

As a result from numerous workshops with the participants involved in the mentioned example we found out that a pure workflow approach is not sufficient to support such a process adequately. Therefore we have established an integrated approach that supports the characteristics of such cross-organisational e-Government processes while incorporating collaborative aspects. We also developed a corresponding platform to support such processes. Thus it guarantees interoperability within the emerging e-Government landscape in Switzerland. To validate the applicability of our approach and platform we have implemented the e-Government process tax declaration of companies. Currently we investigate how to adopt further MDD practices in the context of implementing solutions for other cross-organisational e-Government process based on our approach and platform. For the future work we aim at a comprehensive workbench that will support the realisation of cross-organisational e-Government.

5. References

- [1] Beer, D.; Höhne, S.; Peterson, H.; Pöhnitzsch, T.; Rüniger, G.; Voigt, M., Designing a Distributed Workflow System for E-Government, in: Proceedings of the 24th IASTED Int. Conf. on Modelling, Identification, and Control, ACTA Press, Innsbruck, Austria, 2005, 583-588.
- [2] BFS Schweiz, SEDEX Handbuch, <http://www.bfs.admin.ch/bfs/portal/de/index/00/00/sedex/02.html>, 2008.
- [3] Cajander, A.; Eriksson, E., Automation and E-government Services-A Widened Perspective, in: Proceedings of the 1st International Workshop on Design & Evaluation of e-Government Applications and Services DEGAS 2007, ISSN 1613-0073, 2007, 3-6.
- [4] Wauters, P.; Nijskens, M.; Tiebout, J., The User Challenge Benchmarking. The Supply Of Online Public Services. 7th Measurement, Prepared for the European Commission Directorate General for Information Society and Media, http://www.de.capgemini.com/m/de/tl/EU_eGovernment_Report_2007.pdf, 2007.
- [5] Dustdar, S., Caramba - A Process-Aware Collaboration System Supporting Ad Hoc and Collaborative Processes in Virtual Teams, Distributed and Parallel Databases, Volume 15, Issue 1, Kluwer Academic Publishers, Special Issue on Teamware Technologies, 2004, 45-66.
- [6] EFD Schweiz, Event Bus Schweiz. Konzept und Architektur, <http://www.isb.admin.ch/themen/egovernment/00069/index.html>, 2006.
- [7] Feldkamp, D.; Hinkelmann, K.; Thönsen, B., KISS – Knowledge-Intensive Service Support: An Approach for Agile Process Management, in: A. Paschke, Y. Biletskiy (Hrsg.): Advances In Rule Interchange and Applications, International Symposium RuleML 2007, Springer-Verlag, 2007, 25-38.
- [8] Gugliotta, A.; Cabral, L.; Domingue, J.; Roberto, V.; Rowlatt, M.; Davies, R., A Semantic Web Service-based Architecture for the Interoperability of E-government Services, in: Proceedings of the Workshop on Web Information Systems Modeling Workshop (WISM 2005) in conjunction with the 5th International Conference on Web Engineering (ICWE 2005), Sydney, Australia, 2005.
- [9] Guttman, M.; Parodi, J., Real-Life MDA: Solving Business Problems with Model Driven Architecture (The OMG Press), Morgan Kaufmann Publishers Inc, 2006.
- [10] Heck U.; Rogger A., Knowledge Management for eService-Delivery: A Conceptual approach, in: Maria Wimmer (Ed.) 2004: KM in eGovernment, Springer Lecture Notes in Computer Science, ISBN 3-540-22002-X, 2004, 1-8.
- [11] Heck, U.; Rogger A., Service-oriented Computing within e-Government – a conceptual approach for eService-Delivery, in: Proceedings of the 4th Eastern European eGov days in Prague 2006, 2006.
- [12] Karagiannis D.; Kühn H., Metamodelling Platforms, Proceedings of the Third International Conference on E-Commerce and Web Technologies 2002, Lecture Notes In Computer Science, Vol. 2455, 2002.
- [13] Punia, D. K.; Saxena, K. B. C., Managing Interorganisational Workflows in eGovernment Services, in: Proceedings. of the 6th Int. Conf. on Electronic Commerce, ACM Press, 2004, 500–505.
- [14] Schedler, K.; Summermatter, L., E-Government: What Countries Do and Why: A European Perspective, in: G. Curtin, M. Sommer, V. Vis-Sommer (Hrsg.), The World of E-Government, The Haworth Press, 2003, 255-277.
- [15] Schroth, C.; Schmid, B., A Modular Reference Architecture Framework for Electronic Cross-Organisational Interoperation, in: Proceedings of the Seventh international EGOV conference 2008 (EGOV 2008), Springer Lecture Notes of Computer Science, Turin, Italy, 2008, 303-314.
- [15a] Schroth, C., A Reference Model for Seamless Cross-Organisational Collaboration in the Public Sector. In Multikonferenz Wirtschaftsinformatik 2008 (M. Bichler, T. Hess, H. Krcmar, U. Lechner, F. Matthes, A. Picot, B. Speitkamp, P. Wolf, Editors), Berlin: GITO-Verlag, Munich, Germany, 2008.