

Association for Information Systems AIS Electronic Library (AISeL)

BLED 2005 Proceedings

BLED Proceedings

December 2005

Process Modelling Notations for eGovernment: An Assessment of Modelling Notations for Identity Management

David Brain
University of Surrey

Philip Seltsikas
University of Surrey

Deemple Tailor
University of Surrey

Follow this and additional works at: <http://aisel.aisnet.org/bled2005>

Recommended Citation

Brain, David; Seltsikas, Philip; and Tailor, Deemple, "Process Modelling Notations for eGovernment: An Assessment of Modelling Notations for Identity Management" (2005). *BLED 2005 Proceedings*. 40.
<http://aisel.aisnet.org/bled2005/40>

This material is brought to you by the BLED Proceedings at AIS Electronic Library (AISeL). It has been accepted for inclusion in BLED 2005 Proceedings by an authorized administrator of AIS Electronic Library (AISeL). For more information, please contact elibrary@aisnet.org.

18th Bled eConference

eIntegration in Action

Bled, Slovenia, June 6 - 8, 2005

Process Modelling Notations for eGovernment: An Assessment of Modelling Notations for Identity Management

David Brain, Philip Seltsikas, Deemple Tailor

University of Surrey, UK

d.brain@surrey.ac.uk, p.seltsikas@surrey.ac.uk, d.tailor@surrey.ac.uk

Abstract

This paper assesses the suitability of five of the most commonly used and widely accepted generic process modelling notations for modelling eGovernment identity management processes. The selection of an appropriate process modelling notation is critical to the success of the process analysis to be performed. Unless all of the elements that influence process development are represented by the modelling notation, reengineering efforts that stem from such analyses are at serious risk of failure.

1. Introduction

Since the creation of process charting theory in the early 1920's (Graham 2004) both academics and commercial organisations have employed process engineering/reengineering methodologies and supporting notations for the elicitation, documentation and analysis of organisational processes (Scholz-Reiter and Stickel 1996). Consequently, dozens if not hundreds of notations have been developed, where the vast majority have been designed to suit the specific needs of a particular case or context (Andersen et al., 2005). Only a handful of theorists have ventured to create generic notations for the modelling of industry and context unspecific processes.

The authors reflect upon their experience in modelling eGovernment process within this paper. They have been specifically concerned with the Identity Management aspects of these processes. When selecting a notation for representing Identity Management (IdM) process models in an eGovernment context, specific consideration was paid to selecting a notation to facilitate the *modelling of the unusual constraints, requirements, resources, inputs and outputs* that influence process design. Bespoke notations have not been created specifically for the modelling of IdM processes, thus a range of generic notations were considered and assessed.

This paper draws conclusions based upon an assessment of the suitability of the most commonly used and widely accepted generic Process Modelling Notations (PMN's). The criteria for assessing the existing generic PMNs have been developed in prior research (Brain, Seltsikas. 2005). The next section of this paper (Section 2) outlines the criteria and establishes the 'requirements' that a suitable notation ought to fulfil.

2. Notation Requirements

Many eGovernment processes operate in a complex context in which political, ethical, legislative, technical, and privacy issues can be of impact. Since any new IdM process in government must be designed upon an understanding of the exiting political, ethical, legislative, technical, and privacy principles, it is paramount to the success of process analysis that the notation facilitates not only the representation of 'how' the process is structured, but also the rationale concerning 'why' the process is structured in such a manner (Becker et al 2004). Failure to represent all of the requirements and constraints through the notation will restrict, and potentially mislead the process analysis (Davenport 1993). Many notations have been developed to address various aspects of the requirements mentioned, such as Information Systems Security Analysis and Design (Kokolakis 2000), yet none of these have focussed on satisfying the specific requirements of analysing IdM aspects concerning eGovernment. In this context, success in process analysis therefore hinges on the abilities of the notation to represent these [contextual] principles (Becker et al 2004).

To provide a benchmark for our assessment of generic PMN's, the following notation requirements were established. These have been produced through an extensive review of the existing literature surrounding IdM in the public sector and eGovernment process modelling. Additionally, the notation requirements were established through discussions with industrial government experts and through process elicitation focus groups conducted with several EU member state Government representatives (Brain, Seltsikas. 2005).

2.1 Perspectives of Analysis

To facilitate the multifaceted nature of the notation requirements, the notation of best-fit should facilitate process analysis from three key perspectives: those of 'activity flow', 'information resource' and 'organisational' (Hammer and Champy 1993). This approach provides the ability to model and analyse eGovernment processes, not only from the perspective of a sequencing of activities but also represents the people and organisational structures; and from the perspective of the use of documents and information resources. In the following section, these perspectives are explained further with a description of the associated *key requirements* necessary for the notation.

2.2 Activity Perspective Requirements

One requirement of a suitable notation is the 'activity flow' perspective. This requires the notation to be able to depict the sequencing of *activities and decisions*. This provides the ability to analyse the rationale for the sequencing of activities and their combinations (Harrington 1991). For each process, a representation of all paths (with decision probabilities) is required to assess the likelihood and cause for all eventualities. For each activity, the representation of information inputs and outputs are required to assess what information is presented to the performer (person enacting the process activity), consumed and recorded within the specific stages of the process. The utilisation of

resources must be depicted to facilitate an analysis of the rules that drive automated activities, and so too must the notation represent activity performers to determine the requirements for human resources to be involved. The geographic location of where the activities are performed should also be represented so that security requirements associated to the locations can be determined. Moreover, references to any governing legislation or security requirements must be represented to facilitate an analysis of *existing constraints* placed on the process instance under study.

2.3 Organisational Perspective Requirements

The ‘Organisational’ perspective requires the representation of the performer roles (i.e. roles of the people enacting the process activities), performer requirements, performer qualifications and responsibilities, in addition to the organisational and inter-organisational structures. This can facilitate an analysis of the *performer requirements* and the *trust relationships* between entities and organisations represented in the process model (Harrington et al. 1998). The notation of choice should also facilitate the representation of the performer domain, in terms of whether the performer represents an administration, business, citizen or trusted third party. This information is important in order to provide a context to the process. The organisational structures should facilitate representation for each individual process and the legislation corresponding to the performer, department or organisation should also be depicted.

2.4 Information Resource Perspective Requirements

Finally the ‘Information Resource’ view would provide a context in which to analyse documents and electronic data sources involved in the process (Davis 1983; Dennis and Wixom 2000; Kock 1999). This facilitates further analysis of information flows (personal, identity and case related) as well as the implied trust relationships between entities. The notation of choice must represent the entities that possess and issue each information resource, in addition to any corresponding legislation and data attributes belonging to the resources.

Through analysing all three of these perspectives as described in sections 2.2-2.4 above, the political, social, ethical, technological and legal *constraints and requirements acting on a specific IdM process can be identified*. A suitable process modelling notation should encompass the ability to represent all elements of process through each of these three perspectives (Activity, Organisational and Information Resource).

3 Analysis of Existing Process Modelling Notations

This section presents a summary of the analysis performed on the five most commonly used and widely accepted generic PMN’s in terms of their suitability in representing IdM processes in an e-Government context. Those chosen for assessment are: IDEF0, LOVEM-E, ARIS, BPMS and the newly created BPMN 1.0. The following subsections introduce each commonly used notation, describe the models associated with each notation and outline the result of our analysis regarding the notations suitability for modelling eGovernment IdM processes.

3.1 IDEF0

The 'Integration DEfinition for Function modelling' (IDEF0) process description capture method was originally developed in 1993 by the Integrated Computer Aided Manufacturing (ICAM) Program (Hunt 1996) and was funded by the U.S. Air Force. The notation was originally commissioned to provide a generic comprehensive modelling methodology for technical system analysis and development within the US public sector. However, as its popularity grew within the public sector, many private organisations also implemented the notation for commercial modelling projects (IDEF0, 1993). The notation consists of four main components, process maps, glossaries, For Exposition Only (FEO) Diagrams and accompanying descriptive text in paragraph form. The IDEF0 notation splits activities into a hierarchical structure of diagrams, each representing a maximum of six activities as shown in figure 3.1.1.

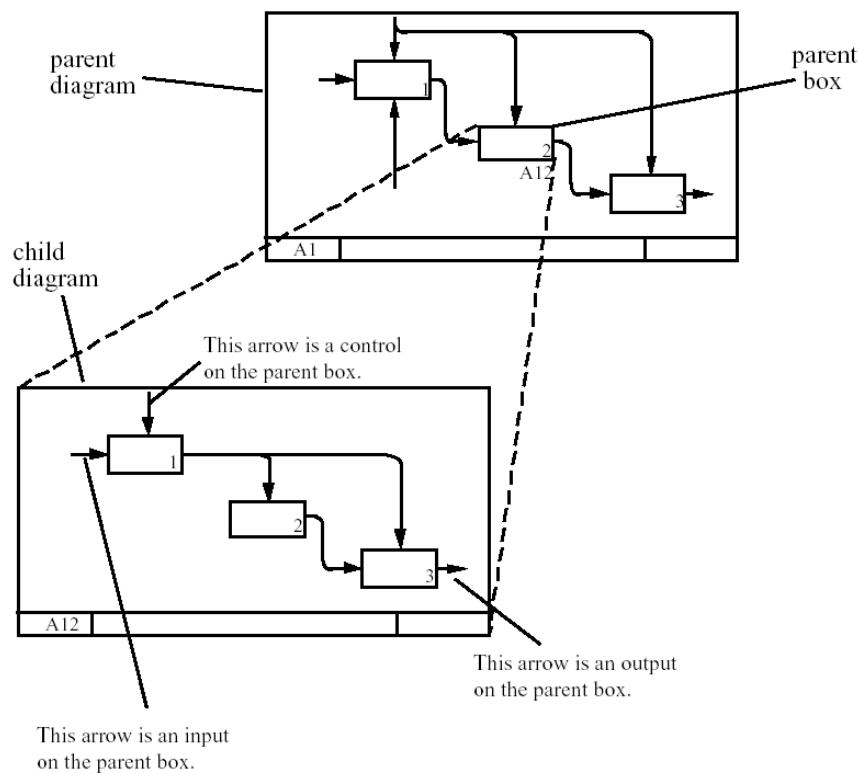

Figure 3.1.1: IDEF0 Notation Structure (ICAM 1993)

Inputs, outputs, constraints (referred to as controls in IDEF0) and resources, (separately defined as both mechanisms and calls) are represented graphically within the notation as arrows, either entering or exiting the activity (function) box, as shown in figure 3.1.2. At the uppermost levels in the hierarchy activities are defined conceptually and then progressively through the layers the definitions become more concise with the level of detail increasing.

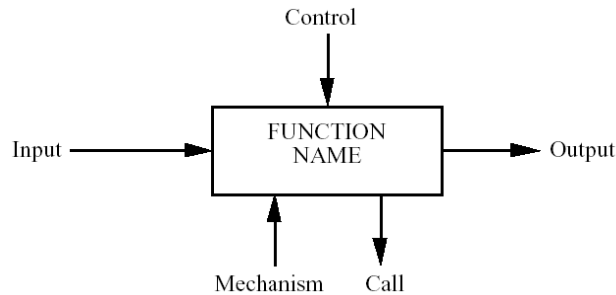

Figure 3.1.2: IDEF0 Function Box (ICAM 1993)

The hierarchical structure of the diagrams aids the creation of manageable sized diagrams. However, this makes the representation of parallelism of activities nested within separate sub-processes, or the representation of the resulting paths of decisions and loops, very difficult to display. Such a structure also makes it practically impossible to follow the flow of information and resources *between activities within different sub-process models*.

The constraint with using such an unstructured notation for an inter-organisational project (i.e. the representation of inter-organisational processes) concerns the ability to ensure the consistency of representation in the accompanying text. The descriptive ‘paragraphs’ rely on the modeller(s) perception of what the most relevant details are in the unstructured description. The notation needs to appear as if it has been created by one mind and this requires an immense amount of coordination and communication between the modellers (Plaia and Carrie 1995).

In summary, due to the unstructured approach to documentation and the inability of the IDEF0 notation to represent the *working environment and information flows*, this notation is inappropriate for modelling IdM aspects of Government processes. The IDEF0 documentation does not provide a means to analyse process information usage or the specific constraints which are critical in order to reengineer a process. Furthermore, the structure of the documentation makes process flow analysis very difficult, and it does not provide a method to graphically represent elements such as the location of activities, activity automation or performer domains (Zakarian, Kuisiak 2000).

Some of these shortcomings were overcome by IDEF3, which was developed in 1995 by a private company, ‘Knowledge Based Systems Incorporated’ (KBSI) who adopted the IDEF framework. IDEF3, the ‘Process Flow and Object State Description Capture Method’, was aimed at ‘providing a more structured method for expressing knowledge about how a system, process or organisation works’ (Mayer et al. 1995). The notation is distinct from IDEF0 and as it has been constructed outside of the ICAM program. It cannot be considered as a replacement to IDEF0, although many organisations use IDEF3 alone for their process modelling exercises.

Although the IDEF3 PMN can represent additional process details in reference to object states (an element missing from IDEF0), it is by no means an extension to the notation. IDEF3 can be seen as an addition to IDEF0 but to use both would require considerable *modelling redundancy* to represent an entire process (Plaia and Carrie 1995). Considering that other notations can represent all the information obtained from IDEF0 and 3 in a single model, making the modelling both easier and more comprehensible, it is difficult to find further justification for the suitability of using this notation to model IdM processes.

3.2 LOVEM-E

The ‘Enhanced Line of Visibility Enterprise Modelling’ (LOVEM-E) methodology was developed in the mid 1990’s by IBM (Canada) as the successor of the original LOVEM notation. The methodology was created to assist IBM consultants with the analysis of customer facing services by modelling the business processes visible to the client, specifically for engineering/reengineering purposes. The methodology has since been adopted by many organisations to support Business Process Engineering/Reengineering (BPE/BPR) initiatives and to provide a process modelling interface to IBM’s WebSphere MQ series workflow application.

Within the methodology there are four structured process modelling ‘charts’ defined, which are used in conjunction to capture all elements of the process. These are: ‘Architecture Line of Visibility Chart (ALOV)’, ‘Logical Line of Visibility Chart (LLOV)’, ‘Physical Line of Visibility Chart (PLOV)’ and finally the ‘Job Line of Visibility Chart (JLOV)’.

3.2.1 ALOV

The ‘Architecture Line of Visibility’ chart provides the conceptual overview to the process. Activities are defined at a high level and can only be assigned to the rigid categories of: Customer, Marketer, Fulfiller or Settler. Each activity is categorised as either relating to inquiry management or change management. An example of an ALOV model is shown in figure 3.2.1.1. The ALOV model provides a broad overview of the entire process which seeks to summarise the brief details regarding the inputs, outputs, constraints or resources, as further information is represented in the subsequent models.

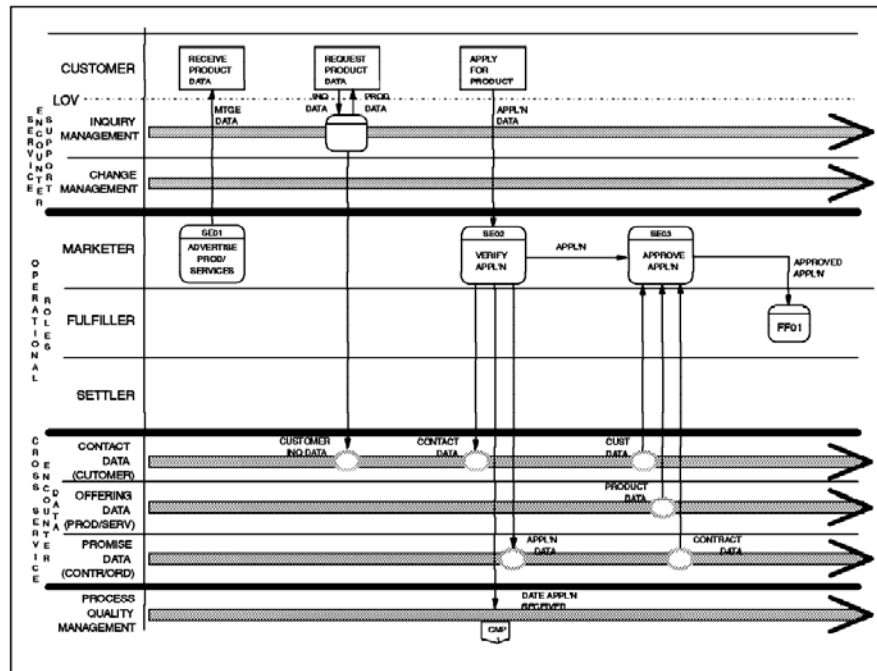

Figure 3.2.1.1: LOVEM-E ALOV Example (Helton et al. 1995)

3.2.2 LLOV

The second model is the ‘Logical Line of Value’ Chart. This model is still at a conceptual level, deployed to identify only generic functions and processes showing which activities require which specific data. Because this is still at a conceptual level it doesn’t explore factors such as existing systems and geographic locations, but aims to provide a stable view of the process path. This representation is facilitated through the restructuring of the swimlanes from generic roles into generic functions such as ‘Sell’, ‘Order’, ‘Supply’, ‘Distribute’ and ‘Settle’. Whilst remaining at a high level, this model starts to explore the activity inputs and outputs. An example of the model is shown in figure 3.2.2.1

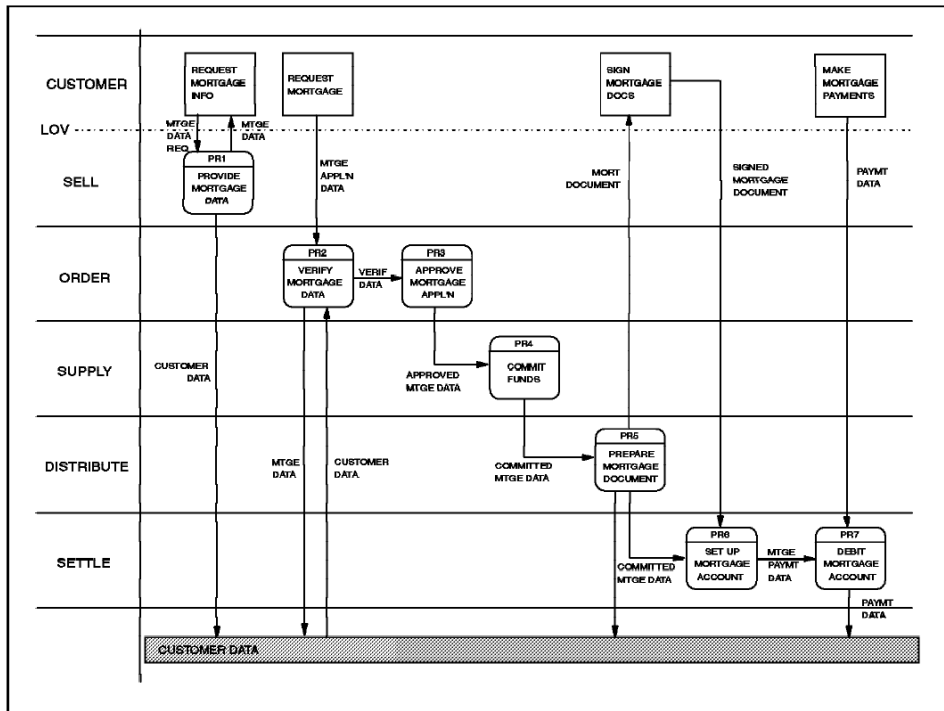

Figure 3.2.2.1: LOVEM-E LLOV Example (Helton et al. 1995)

3.2.3 PLOV

The ‘Physical Line of Visibility’ Chart is used to represent the physical constraints acting on the process and the timeframe in which these activities occur. This model provides the specific detail concerning the process by also introducing objects and object states, as well as resources and activity automation. Swimlanes are used to represent specific roles, which makes it easy to identify the responsibilities of the performer, yet does not provide any context to the organisational structure, as shown in figure 3.2.3.1.

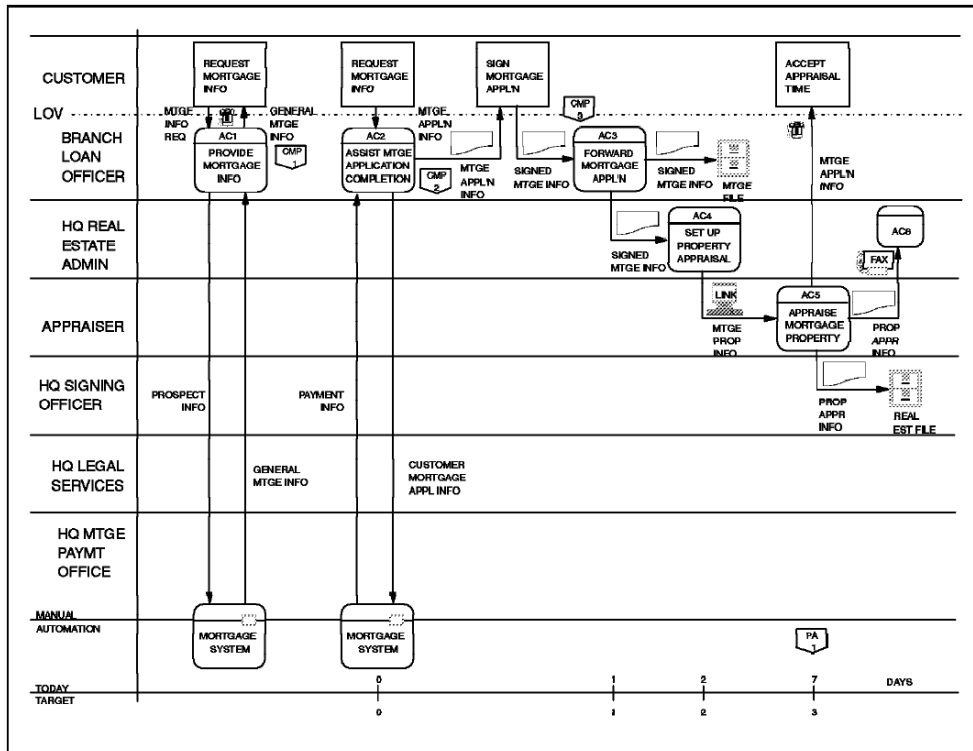

Figure 3.2.3.1: LOVEM-E PLOV Example (Helton et al. 1995)

3.2.4 JLOV

The final model in the notation is the ‘Job Line of Visibility’ chart. This model represents the sequential ordering of activities being performed by the personnel involved within the process. A separate JLOV is used for each performer, specifically representing where each performer interacts with others, including details concerning the activities they perform, which resources are used, the inputs they require, outputs they generate and finally those activities that are automated. A timeline across the bottom of the chart (as in the PLOV) is also used to provide context as seen in figure 3.2.4.1.

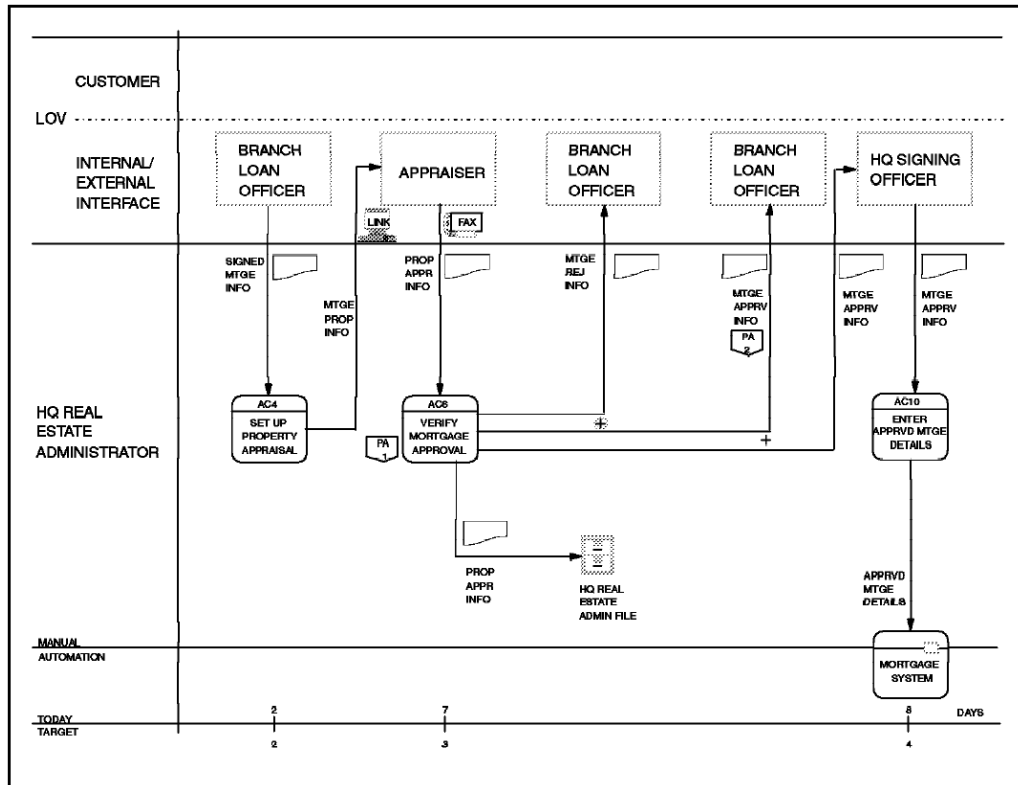

Figure 3.2.4.1: LOVEM-E JLOV Example (Helton et al. 1995)

3.2.5 Summary

The notation is generally well suited for the modelling of commercial processes. The structure is targeted at enterprises and therefore the categories defined for the performer roles in the ALOV chart would need to be customised to suit the government setting. The notation presents systematically the ordering of activities and the means of representing inputs, outputs and resources, which is flexible enough to encompass the representation of data transfer at an attribute level, although such an approach would produce large diagrams. Both requirements and constraints are not well represented in any of the charts and it would be difficult to adjust the notation to represent legislative or security considerations. The notation does not facilitate the representation of organisational structures or provide a means to expand on the content of inputs and outputs which makes assessing the environment and reengineering possibilities difficult.

Overall the notation has been specifically designed for the modelling of enterprise processes and as such is unsuitable, without the customisation of existing and addition of new models, for the modelling of public sector processes. For these reasons LOVEM-E has not been deemed inappropriate for use within the project.

3.3 ARIS- Architecture of Integrated Information Systems

The 'Architecture of Integrated Information Systems' was originally developed in the early 1990's by the Institute for Information Systems (Iwi) at the University of Saarland in Germany (Scheer 1998). The architecture is comprised of a methodology using supporting notations to facilitate process elicitation for analytical purposes. This approach uses a variety of models to depict a single process to enable the viewer to visualise the

process from five different perspectives thus allowing analysis at a component level. The perspectives which are facilitated through ARIS are represented in figure 3.3.1 below, the ARIS house.

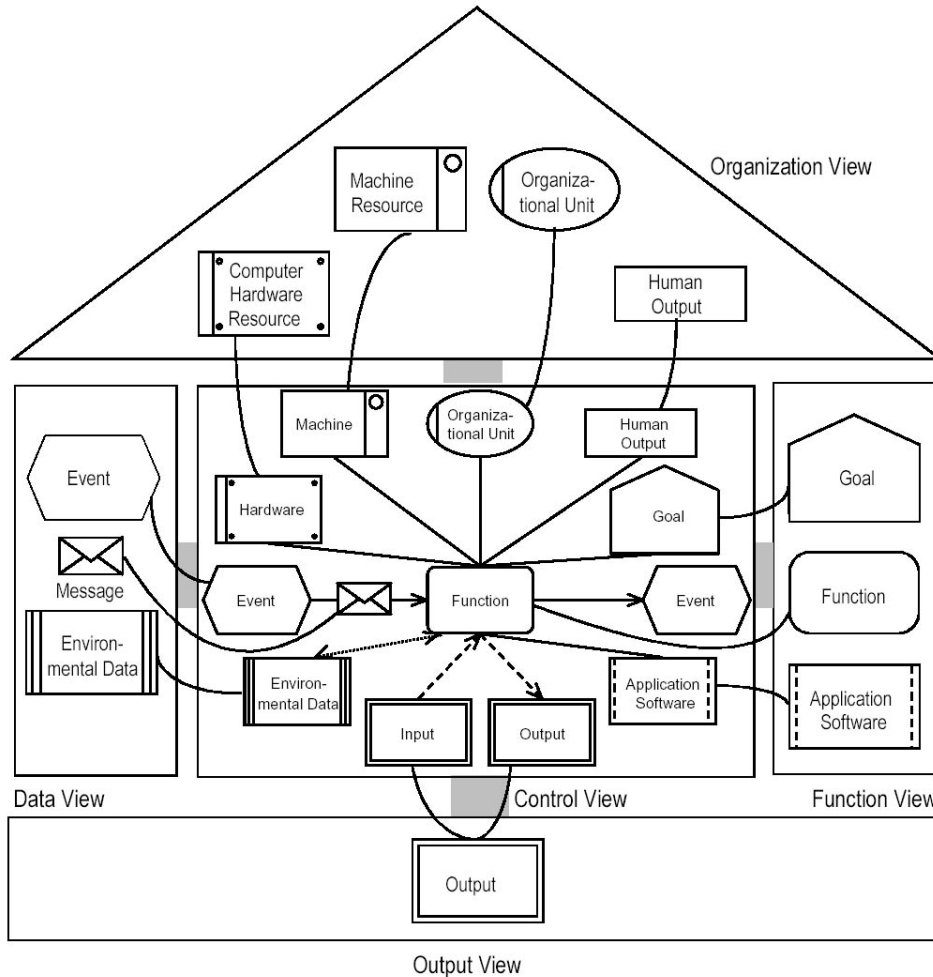

Figure 3.3.1: Views of the ARIS House (Scheer 1998)

The five views: ‘Data’, ‘Function’, ‘Organisation’, ‘Output’ and ‘Control’ are facilitated through the notation depicted in several separate models. When assessing the notation for suitability the Organisational, Interaction, Function, Output, Information flow, Consolidated Business Process diagrams and finally Event driven Process Chains were studied in terms of their appropriateness in depicting IdM processes. Collectively these diagrams represent the most suitable models from the library for each of the views presented in figure 3.3.1. The following section analyses the appropriateness of this approach, by assessing each of these diagrams in detail.

3.3.1 Organisation Diagram

The ‘Organisational Diagram’ provides the organisational context surrounding the process, by providing a means to model the departmental structure, organisation types, performer requirements, locations, and resource requirements. The meta-model for this

diagram is shown in figure 3.3.1.1, which provides greater freedom in modelling all elements required for analysis. As expected from a generic notation, there are limitations concerning the graphical categorisation of elements; for example when representing whether a requirement is legal or technical or when a location falls in to the category of administration, business, citizen or trusted third party controlled. Such representation is required in this context to aid comprehension when producing documentation for knowledge sharing purposes with untrained viewers as this is typically the case when discussing findings and potential solutions with government representatives.

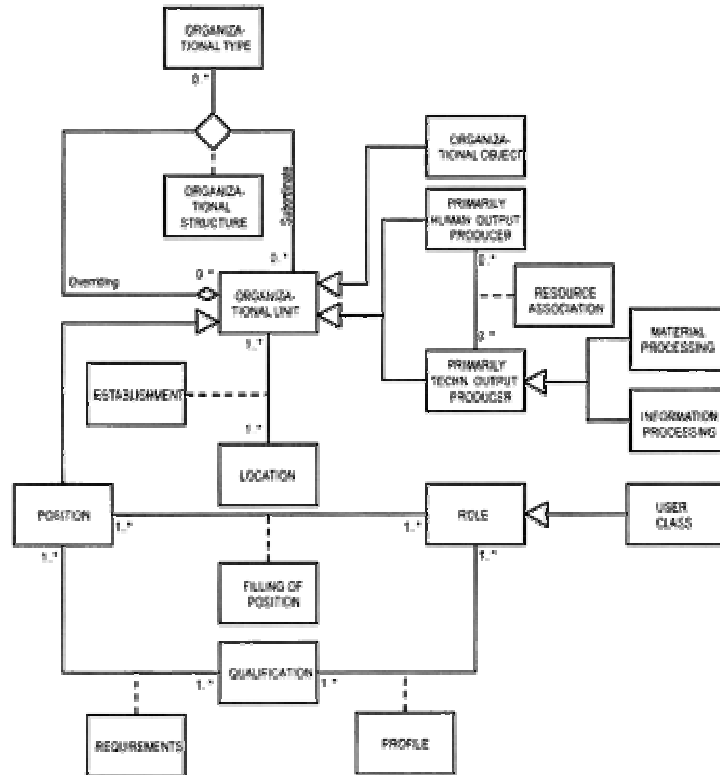

Figure 3.3.1.1: Meta model of Hierarchical Organisation (Scheer 1999)

3.3.2 Interaction Diagram

The ‘Interaction Diagram’ provides an overview of the human aspects in connection with the process. The model structure is focused on the relationships between entities within the context of the process, as opposed to the organisation. This facilitates the analysis of responsibilities, where demands are placed on the various performer roles within the confines of the process. An example of an ARIS Interaction diagram is shown in figure 3.3.2.1; note both the organisation’s employees and external entities are modelled alike, thereby defining the internal and external dependencies, as well as the performer roles and their responsibilities.

This diagram does not facilitate the representation of constraints or requirements surrounding the interaction of performers. Such representation would be useful for analysing the implications of potential process changes, where the constraints could be legislative, ethical or privacy related such as those restricting how a trusted third party could interact with a citizen. Such representation would be essential for assessing the potential implications for example, when implementing a trusted third party service.

These constraints could be overcome by representing this in the organisational diagram using the requirements object.

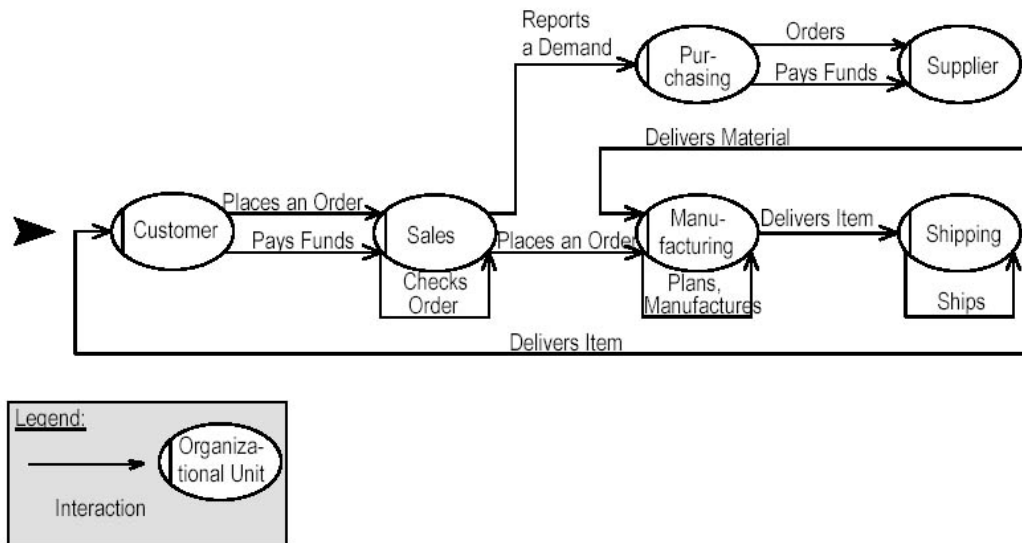

Figure 3.3.2.1: ARIS Interaction Diagram (Scheer 1998)

3.3.3 Function Flow Diagram

The 'Function Flow Diagram', provides the aforementioned functional view of the process shown in figure 3.3.1. Whereas the 'Integration Diagram' displays the communication between various entities, the Function Flow Diagram depicts the actual assignment to, and ordering of, activities (example shown in figure 3.3.3.1). This model does not represent the associated constraints or requirements relating to activities (e.g. legislative or geographic restrictions) therefore its sole representation does not provide sufficient detail for analysis alone. The model does however provide a clear representation of workflows and performers, which can be difficult to portray in the consolidated business process diagram.

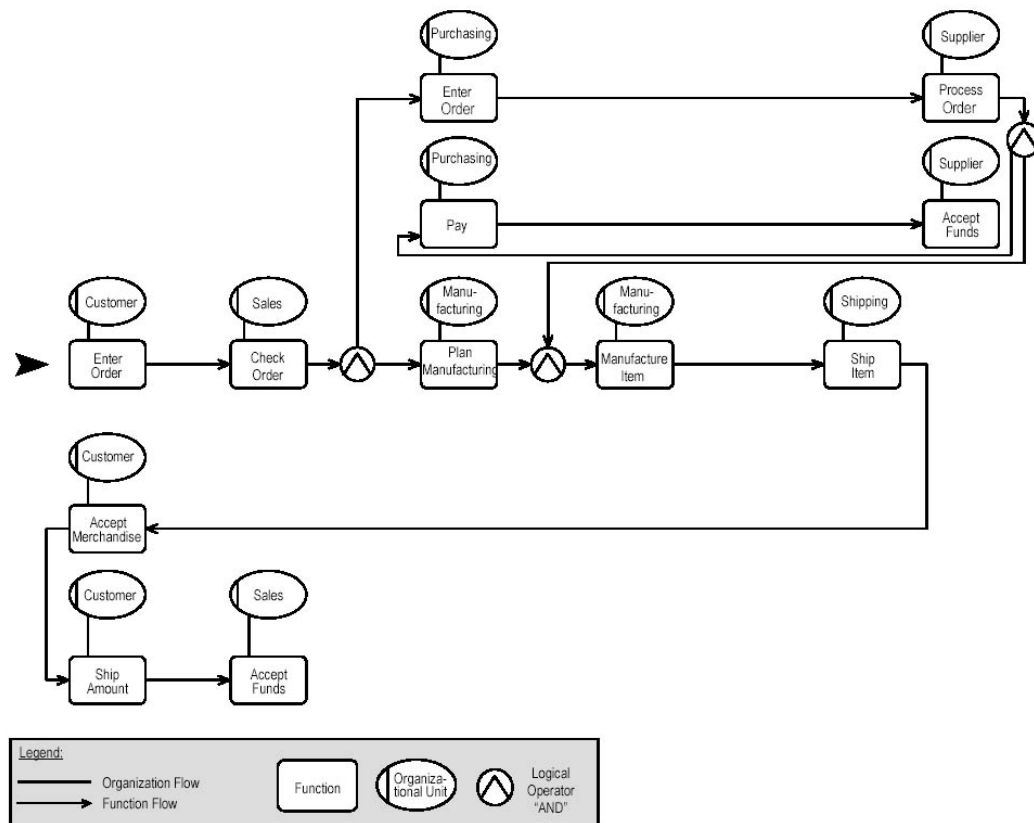

Figure 3.3.3.1: ARIS Function Flow Diagram (Scheer 1998)

3.3.4 Output Flow Diagram

The 'Output Flow Diagram' provides additional context to the process by representing a view of the various states of the objects generated or modified by the activity in the process. As shown in figure 3.3.4.1 the 'Output Flow Diagram' is structured upon the underlying function flow (structuring of activities and decisions) as defined in the Function Flow Diagram. Where more than one objects state change occurs as the result of performing a single activity, the notation splits the process flow into parallel paths, one for each object. This approach facilitates the representation of all process changes in one model for an individual process. The sacrifice for achieving this results in the creation of large and cluttered diagrams when modelling numerous process paths with several activities changing the state of multiple objects. In the context of IdM processes this could be particularly problematic as the assessment of an identity may require checking several information resources per sub-process area, thereby resulting in the creation of numerous object paths along several process paths.

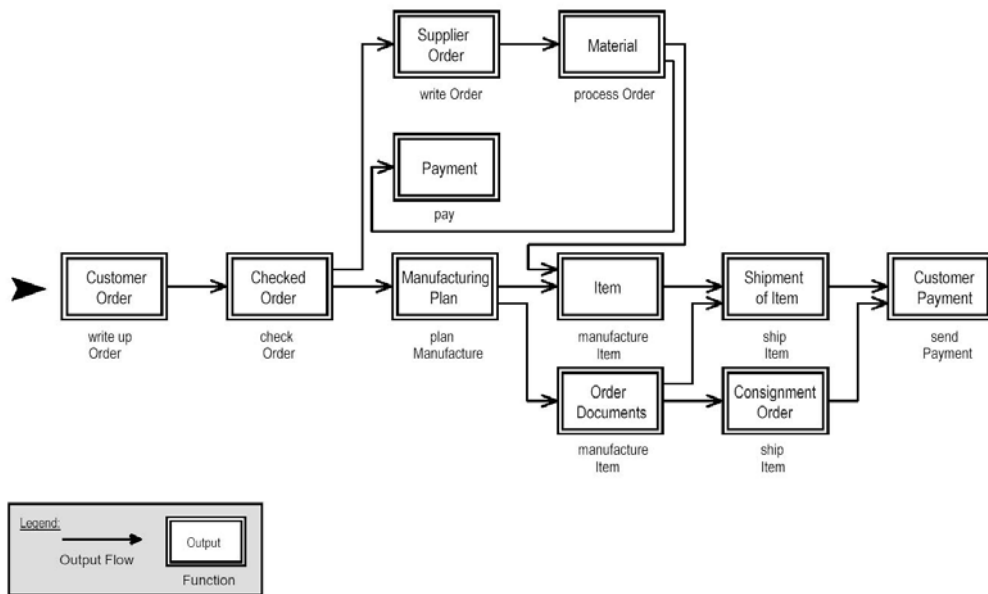

Figure 3.3.4.1: ARIS Output Flow Diagram (Scheer 1998)

3.3.5 Information Flow Diagram

The 'Information Flow Diagram' provides the data view of the process. This model is used to represent the way in which data is recorded and manipulated by the performance of the process activities. The diagram depicts the source of where the information resource originates and at which points during the performance of the process; information is consumed or manipulated in the provision of an information service. The purpose of this model seeks to generate a deeper context to the flow of information, which is fundamental in creating a holistic representation of the process. This is essential for the analysis of how identity data is being managed. Figure 3.3.5.1 displays an example of an 'Information Flow Model'.

In general the model works well for depicting information usage in terms of activity inputs and outputs, thereby providing the necessary context to the process, which is essential for analysis. The 'Information Flow Diagram', along with the 'Output Flow Diagram' provides the details of all object changes both in terms of physical objects and information resources. The concern for using such an approach leads to a diagram that does not represent the underlying function flow. This thereby separates this model from the process perspective and in some cases can make the models cognitively challenging to comprehend.

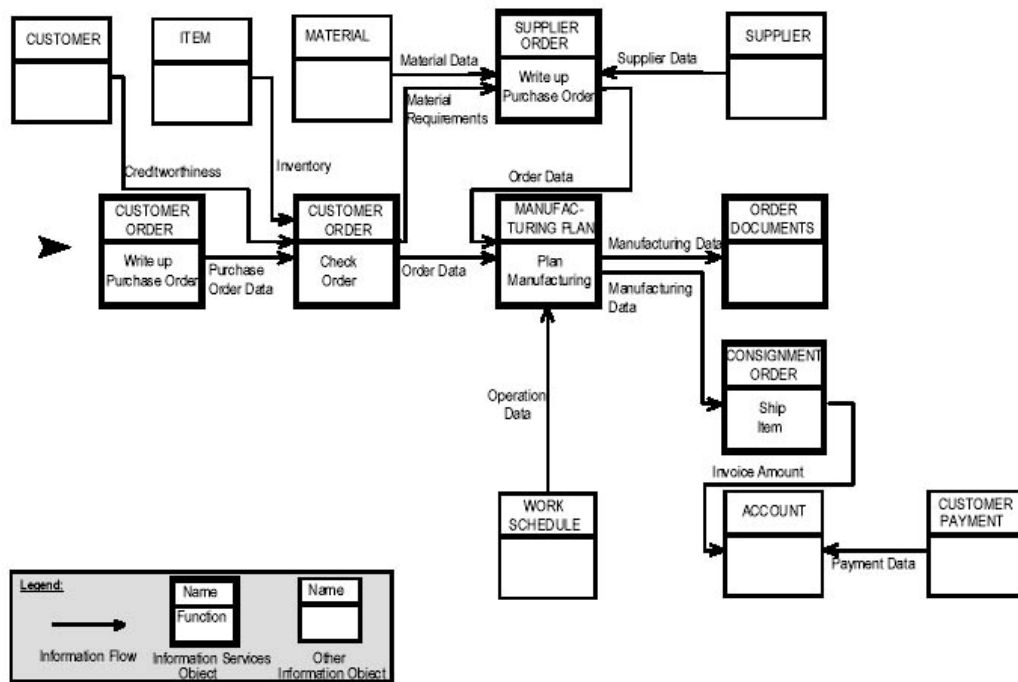

Figure 3.3.5.1: ARIS Information Flow Diagram (Scheer 1998)

3.3.6 Consolidated Business Process Diagram

The 'Control View' of the process represents the culmination of all of the above diagrams to create the single 'Consolidated Business Process Diagram'. The 'Consolidated Business Process Diagram' evolves from the underlying function flow, presented in the 'Function Flow Diagram' which depicts activity outputs, information resources and organisational elements, where this diagram provides a comprehensive view of the entire process. In practice, as every element is presented graphically in containers, even simple processes can produce large and complex diagrams. Figure 3.3.6.1 displays the notation for the modelling of a single activity (function) within a larger process. For the modelling of IdM processes within a government context, this diagram would become significantly more complex with the depiction of legal, social, ethical and geographical requirements and constraints at an activity level. Although this would produce the required information for the purposes of analysis, this may prove to be problematic as a means of representation in knowledge sharing and process discussion activities.

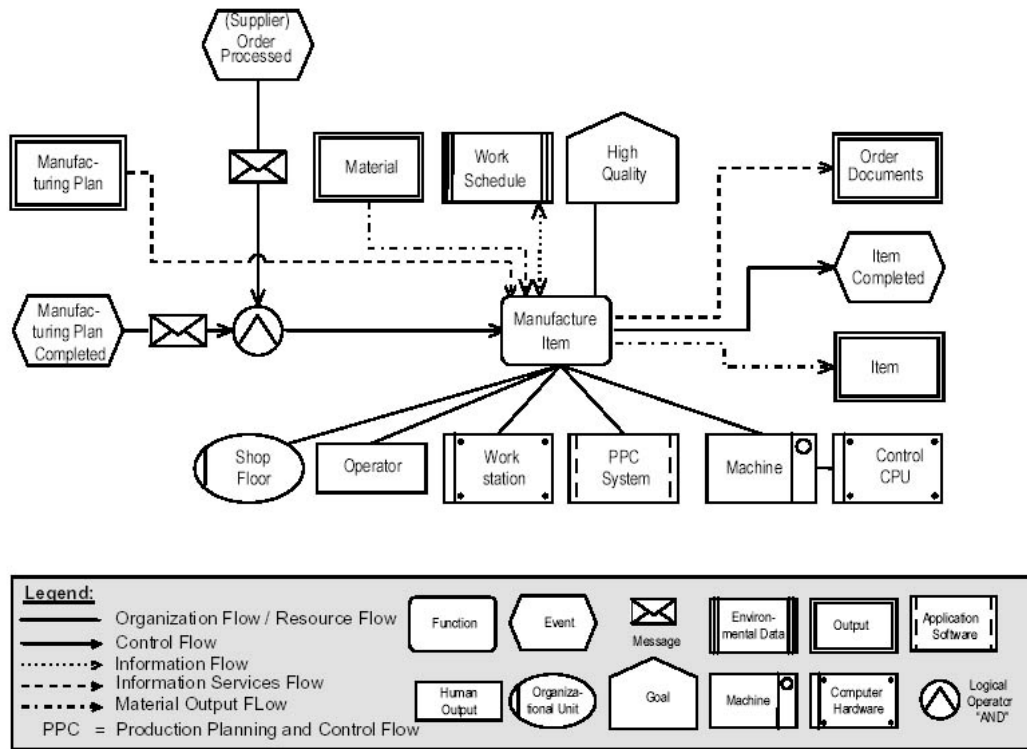

Figure 3.3.6.1: ARIS Consolidated Business Process Model (Scheer 1998)

3.3.7 Event-driven Process Chains (EPC's)

Alongside the 'Consolidated Business Process Model', within the ARIS notation exists 'Event-driven Process Chains' (EPC's). Either of these models can be used to represent the control view depicted in the ARIS house. Over the past 15 years EPC's have become increasingly dominant in the field with the adoption of the notation by developers and consultants such as SAP who have integrated EPC's in R3 suite.

The notation is similar in structure to the consolidated business process model. Objects are linked with relations, represented by arrows, to a 1:1 relation (exception: logical links). In such a linked chain, objects are varying between events and functions. Each function can additionally be linked with an information object from where information can be gathered or information can be saved.

EPCs consists of the following basic elements:

- Events
 - Are preconditions of functions
 - Can be the result of functions
 - Example: "offer is accepted"
- Functions
 - Represent activities
 - Are triggered by events
 - Result in events
 - Example: "accept offer"

- Linking operators
 - Antivalenz (XOR) (either, or = only exactly one case can happen)
 - Disjunction (OR) (or = one or more cases are possible)
 - Conjunction (AND) (all cases are possible)

Every EPC model starts with at least one event (starting event) and is closed with at least one event (end event). Models enriched with additional information about executing, supporting systems, used data, produced files etc., these EPCs are called extended EPCs (short eEPCs) that can be used in connection with other models of the ARIS concept. Figure 3.3.7.1 provides an example of the ARIS EPC notation.

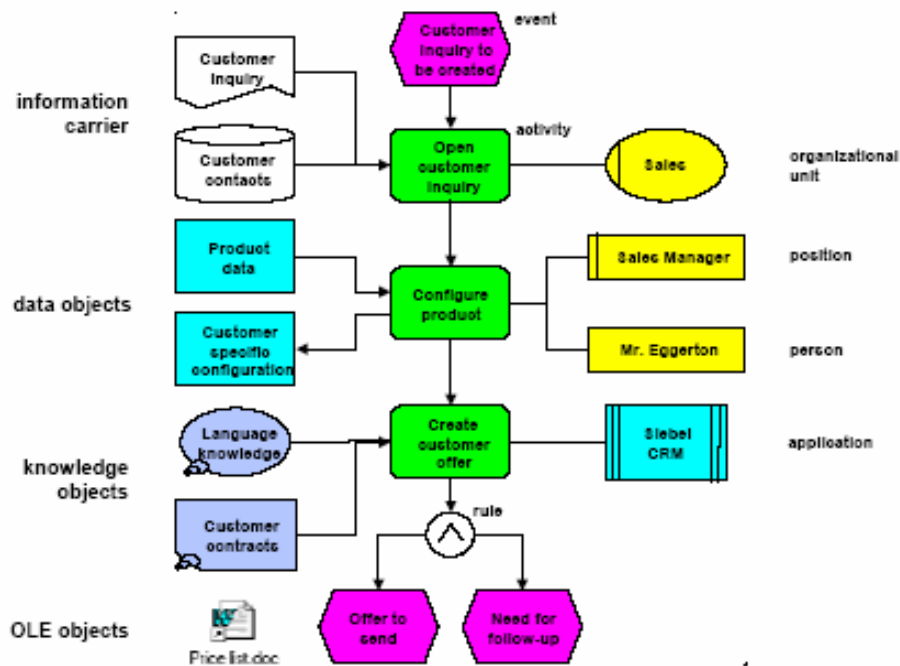

Figure 3.3.7.1: EPCs used in ARIS eGovernment Suite

EPC's are used to provide the 'control view' within the ARIS eGovernment Suite. This notation is suitable for transferring business processes directly into workflow management tools used by the public administrations. The business processes depicted with the described notation do however get rather complex and are not intuitive to understand. Therefore reference processes are implemented in order to facilitate the reorganisation of governmental processes (example electronic file management).

3.3.8 Summary

The ARIS architecture provides an effective notation for process representation. The collection of diagrams presents opportunities to elicit the processes at various levels of detail and enables the emphasis of the analysis to be directed to the specific needs of the research. The notation is defined adequately to capture most possibilities of input, output and resources, however constraints are not easy to represent in any of the diagrams. The notation also lacks options to differentiate graphically between elements (e.g. subsets of

requirements). This is common amongst generic process modelling notations, as, by definition, they have not been designed to represent the specific set of constraints or requirements acting on one industry sector or organisational aspect.

To resolve these issues, the existing notations could be adapted to represent specific constraints relevant to the IdM government context. This would involve mainly an elaboration on the 'Function Flow' and 'Information Flow' diagrams, which would not resolve the aforementioned unsuitability surrounding the creation of documentation for knowledge sharing and process discussion. These factors are not insurmountable, but for the specific needs of this research the notation would require extensive modifications prior to effective deployment.

3.4 BPMN 1.0

The 'Business Process Modelling Notation 1.0' (BPMN 1.0) has been developed by the 'Business Process Management Initiative' (BPMI) a non profit organisation established in 2002 with currently over sixty commercial partners. The BPMI aims to develop an open standard for the modelling and management of business processes. The notation, the BPMI have developed, is similar to both LOVEM-E and EPC which is expected, as both IDS Sheer (the developers of ARIS and EPC) and IBM (the developers of LOVEM) are prominent members of the consortium. The notation (PMN) uses a single model to diagrammatically display all the information relating to the process. The flow models are devised around a sequence of activity and decision objects placed within swimlanes, representing which performers or organisations execute each of the tasks (similar to the LOVEM PLOV model). Unlike the other notations studied, BPMN 1.0 provides an object for modelling triggers such as 'continue process after 1 week' (Figure 3.4.1 shows an example of a process diagram modelled using the notation).

The notation provides a clear display of the process flow and activity decision paths. The information flow is represented by labelled connectors linking activities to performer swimlanes which can produce unmanageable process maps when modelling large and complex processes. Unfortunately the notation does not provide a means to model the organisation structure, requirements or constraints and only focuses on the process flow and not on any of the surrounding contexts. The notation does not support the ability to model the use of resources and is limited in the ability to depict activity inputs and outputs. The graphical representation of requirements or constraints are not supported, thereby making process analysis for system engineering purposes all the more difficult, relying solely on any supporting textual documentation.

In conclusion, although the notation is well supported by industry, it lacks the ability to represent, in sufficient detail, the five elements of a process flow diagram required for analysis (those of activity flows, inputs and outputs, resources, requirements and constraints). For these reasons BPMN has been deemed unsuitable for the modelling of processes within this context.

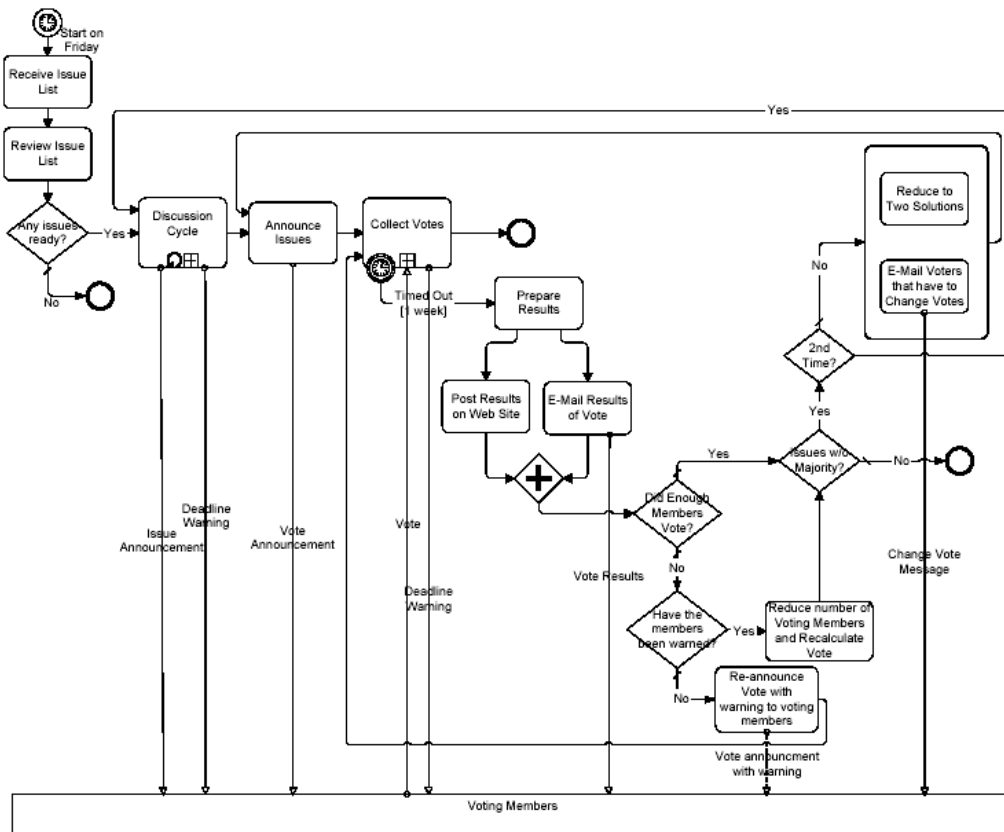

Figure 3.4.1: BPMN Example (BPMI 2004)

3.5 BPMS

The BPMS modelling notation has been designed to facilitate the ‘Business Process Management Systems’ paradigm developed in partnership between the University of Vienna and the Austrian management consultancy BOC GmbH. Like ARIS the notation is only one aspect of a wider methodology and in this case, customisation of the predefined notation is encouraged to map additional process aspects specific to the case. The standard notation is targeted at modelling generic business processes and is constructed through three principle design diagrams, each inter-referencing to create the modelled reality of the process. The three core components are the ‘Process Flow Diagram’ (represented by the ‘Business Processes’ box in figure 3.5.1) for the mapping of activity flows, ‘Working Environment Diagram’ (represented by ‘Performers/Roles’ in figure 3.5.1) for the mapping of organisational structures and resource allocations. Finally the ‘Document Diagram’ (represented by ‘Documents’ in figure 3.5.1) is used for the modelling, and referencing of documents referenced within the process flow.

As illustrated in Figure 3.5.1, these models only go part way in achieving the realisation of the paradigm. The high level ‘Strategy View’ of the process is facilitated by the model ‘Company map’ where the notation utilises UML defined Use Case models to provide context to the roles and responsibilities of the performers. These two elements have not been documented as they do not specifically relate to the modelling of process elements. Lastly the bottom two layers of the diagram represents the paradigm’s ability to realise, implement and execute the developed processes through import into a workflow engine.

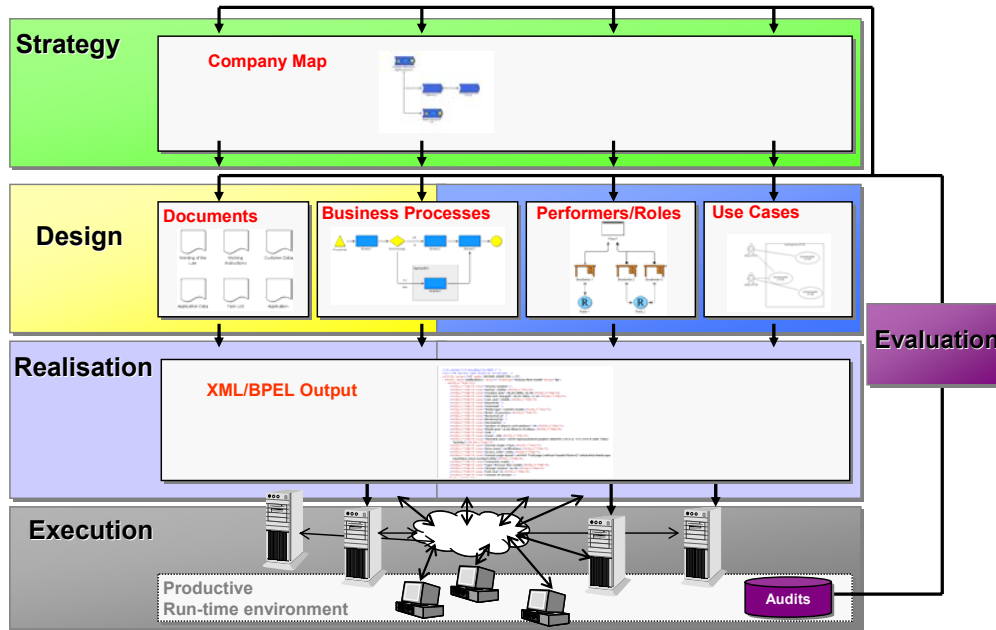

Figure 3.5.1: BPMS Notation relating to BPMS Paradigm

This section will now continue to explore the three elements of the notation relating to the modelling of processes. These are the notations for the ‘Process Flow Diagrams’, ‘Working Environment Diagrams’ and the ‘Document Maps’.

3.5.1 Process Flow Diagram

The ‘Process Flow Diagram’ concentrates on solely representing activity and decisions paths and the use of resources. Each activity, references a performer by role, which is cross referenced in the ‘Working Environment Model’ in addition to any documents used in the ‘Document Model’. This enables the notation to represent complex relationships with several performers, inputs and outputs without compromising the clarity of the diagrams. Swimlanes can also be used to group activities by geographic location. An example of a process flow diagram is shown in figure 3.5.1.1.

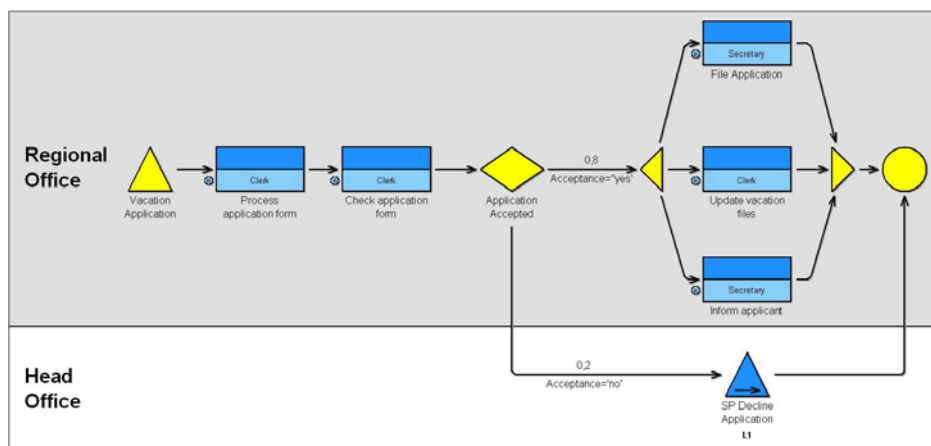

Figure 3.5.1.1: BPMS ‘Process Flow Diagram’ Modelling Notation

3.5.2 Working Environment Diagram

The ‘Working Environment Diagram’ (shown in figure 3.5.2.1) facilitates modelling of organisational structures through the definition of ‘Organisational Units’ (departments or organisations), individual performers (representing specific personnel) and roles (representing job titles or functions). Through the use of several different connectors, the notation enables the modelling of organisational structures (linking personnel working in, and managing, organisational units to those appropriate units) and the use of technical resources through links from any element to resource objects (as represented in the notation by computers). Aggregations are symbolised (represented within figure 3.5.2.1) by the yellow, blue and green boxes) are used to group elements and may be named, for example to represent geographical locations.

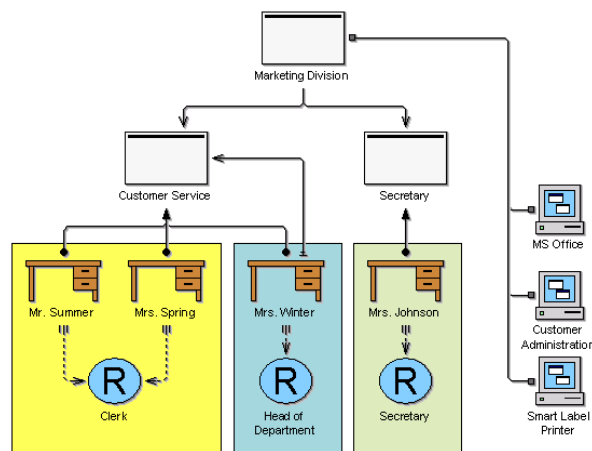

Figure 3.5.2.1: BPMS ‘Working Environment Diagram’ Modelling Notation

3.5.3 Document Diagram

The final of the three core diagrams is the ‘Document Diagram’ (shown in figure 3.5.3.1) which is used to provide additional information concerning the documents referenced from the ‘Process Flow Model’. Within the documentation diagram, the documents can also be linked to copies of the source document for further analysis (which can be in the form of a word, excel, etc file). Aggregations can again be used to group documents to suit the needs of the exercise.

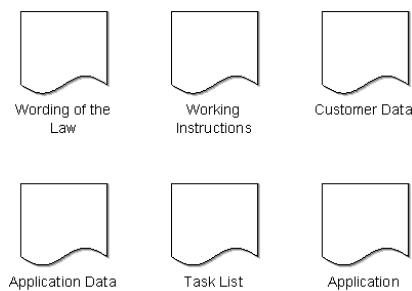

Figure 3.5.3.1: BPMS ‘Document Diagram’ Modelling Notation

3.5.3 Summary

Overall the BPMS notation is suitable for the modelling of generic processes. The notation has been broadly defined to encourage adaptations to meet specific needs. However, this informality in approach can be perceived as a weakness, especially in the modelling of large projects where several modellers are involved. Nevertheless, as the methodology preaches customisation, there is no reason why restrictions cannot be placed to refine the scope of representation.

In summary the BPMS notation facilitates the modelling of activity sequencing, the elicitation of inputs and outputs per activity and the use of resources. For the modelling of constraints, the informality of the language and acceptance of customisation enables modelling to the required level. On the down side the core models do not express the need for representing object states, which provides additional information on object manipulation important for process analysis in this case. Neither does the notation explore in detail the flow of personal information or aspects such as document possession or origin, which have been deemed fundamental for analysing IdM.

To conclude the BPMS notation could be used for the partial modelling of IdM processes within governments. Through significant customisation the modelling requirements could be partially met, although not all of the requirements can be facilitated within the confines of the notations three model structure.

4. Conclusion

This paper has highlighted the key findings of an initial analysis performed on the five most commonly used and widely accepted generic process modelling notations. The key benefits and limitations encountered when assessing each of the PMN's for suitability in modelling IdM processes in the specific context of eGovernment have been identified. This analysis has highlighted a clear gap between the information representation abilities of the generic notations studied and the specific requirements of modelling eGovernment processes that include a representation of Identity Management aspects. The disparate 'capabilities' of each PMN studied are summarised in Figure 4 below.

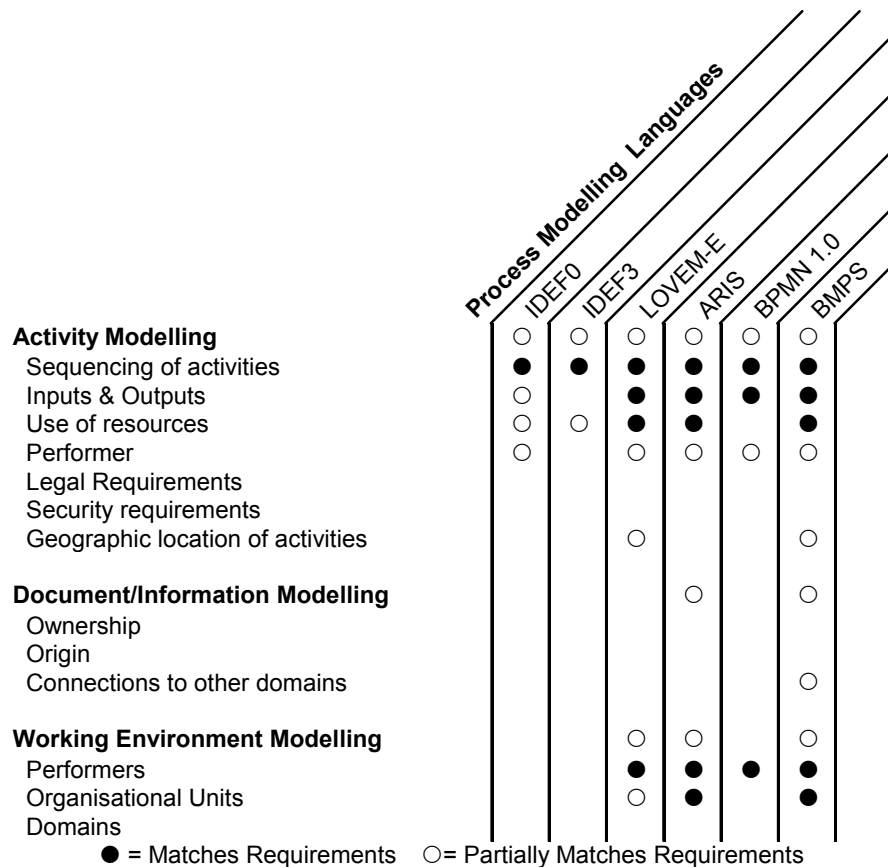

Figure 4.1: Matrix of eGovernment IdM Process Modelling Requirements against Existing PMN's

It is not surprising that the generic notations studied are unsuitable for modelling the *exact* requirements of IdM in eGovernment. The structures of the notations are designed to model context unspecific constraints and requirements and are therefore not designed to graphically represent the *specific* elements impacting on IdM in the public sector such as legislative restrictions or data security. The majority of the notations analysed fail to provide the ability to model important features of this modelling context such as geographic locations, object states, information flows of data ownership. Whilst only two of the notations facilitate a representation of data flows to a satisfactory level of detail for analysing data usage, none provide the means to adequately represent connections between data sources or to facilitate the depiction of document possession or access restrictions, such as those enforced by administrations.

In conclusion, the use of any of the PMN's that were assessed for process modelling in this domain would not only restrict but would potentially misdirect the process analysis. This is because only *partial information* would be represented. By not accurately representing all of the activity inputs, outputs resources, requirements and constraints restricting process redesign, the process analysis to be performed, and resulting recommendations and conclusions would be based on only a *partial knowledge of the process requirements* and thereby prove more hazardous than beneficial to any e-system development. Therefore, as the findings of this research indicates that none of the studied PMN's are suitable for modelling in this context the logical progression is to develop or customise a notation that will.

References

- Andersson, Birger; Bider, Ilia; Johannesson, Paul Erik Perjons (2005) Towards a Formal Definition of Goal-Oriented Business Process Patterns *Business Process Management Journal*, Vol.11(6), 2005
- Becker, J., Algermissen, L., Niehaves, B. (2004) Organisational Engineering in Public Administrations- A Method for process-oriented eGovernment Projects, *ACM Symposium on Applied Computing*. 1385-1389
- BPMI "Business Process Modelling Notation (BPMN)," BPMI (Business Process Management Initiative).
- Brain, D. and P. Seltsikas (2005). Establishing Notation Requirements for the Modelling of Identity Management Processes in the Context of eGovernment. *Eastern European eGov Days 2005, Corvinus University Budapest, Hungary*.
- Davenport, T.H. (1993). *Process Innovation*, Harvard Business School Press, Boston, MA.
- Davis, W.S (1983). *Systems analysis and design: A structured approach*. Reading, MA: Addison-Wesley
- Dennis, A., and Wixom, B.H. (2000). *Systems analysis and design: An applied approach*. New York: John Wiley & Sons.
- Graham (2004) *Detail Process Charting: Speaking the Language of Process*, Wiley, US
- Hammer, M. and Champy, L. *Reengineering the Corporation: A Manifesto for Business Revolution*, Harper Collins, New York, 1993.
- Harrington, J.H (1991) *Business process improvement*. New York: McGraw-Hill
- Harrington, J.H., Esseling, E.K.C., and Van Nimwegen, H. (1998) *Business process improvement workbook: Documentaiton, analysis, design, and management of business process improvement*. New York: McGraw-Hill
- Helton, A., Zulaybar, E., and Soper, P.J.A. *Business Process Reengineering and Beyond*, (1st ed.) IBM Corporation, International Technical Support Organization, 1995.
- Hunt, V.D. *Process Mapping, How to Reengineer Your Business Processes* John Wiley & Sons, Inc., 1996.
- ICAM, I.C.A.M. "Integration Definition for Functional Modelling (IDEF0)," US Secretary of Commerce.
- IDEF0 (1993), "Integration Definition for Function Modeling (IDEF0)", Draft Federal Information Processing Standards, Publication 183 (Fips 183). Available (December 2003) <http://www.idef.com/Downloads/pdf/idef0.pdf>.
- Kock, N. (1999) *Process improvement and organizational learning: The role of collaboration technologies*. Hershey, PA: Idea Group Publishing.
- Kokolakis, S.A., Demopoulos, A.J., and Kiountouzis. (2000) "The use of business process modelling in information systems security analysis and design" *Information Management and Computer Security* Vol.8 No.3 107-116
- Mayer, R.J., Menzel, C.P., Painter, M.K., deWitte, P.S., Blinn, T., and Perakath, B. (1995) "Information Integration for Concurrent Engineering (IICE) IDEF3 Process Description Capture Method Report," Knowledge Based Systems, Inc.

- Plaia, A., and Carrie, A. (1994) "Application and assessment of IDEF3 – Process flow description capture method" *International Journal of Operations and Production Management* Vol 15, No 1, 63-73.
- Scheer, A.W. *ARIS - Business Process Frameworks*, (2nd ed.) Springer-Verlag Berlin Heidelberg New York, 1998.
- Scheer, A.-W. *ARIS - Business Process Modeling* Springer-Verlag Berlin Heidelberg, 1999, p. 218.
- Scholz-Reiter, B. and Stickel, E. (Eds.) (1996) *Business Process Modelling*. Springer-Verlag, Berlin.
- Zakarian, A. and Kusiak, A (2000) "Analysis of Process Models" *IEEE Transactions on Electronics packaging Manufacturing* Vol. 23, No 2 137-147.