

## Association for Information Systems AIS Electronic Library (AISeL)

---

AMCIS 2006 Proceedings

Americas Conference on Information Systems  
(AMCIS)

---

December 2006

# It's All About Who You Know: Informal Network Importance for IS Alignment

Peter Haried

*University of Wisconsin-Milwaukee*

Keshavamurth Ramamurthy

*University of Wisconsin-Milwaukee*

Follow this and additional works at: <http://aisel.aisnet.org/amcis2006>

---

### Recommended Citation

Haried, Peter and Ramamurthy, Keshavamurth, "It's All About Who You Know: Informal Network Importance for IS Alignment" (2006). *AMCIS 2006 Proceedings*. 71.

<http://aisel.aisnet.org/amcis2006/71>

This material is brought to you by the Americas Conference on Information Systems (AMCIS) at AIS Electronic Library (AISeL). It has been accepted for inclusion in AMCIS 2006 Proceedings by an authorized administrator of AIS Electronic Library (AISeL). For more information, please contact [elibrary@aisnet.org](mailto:elibrary@aisnet.org).

# It's All About Who You Know: Informal Network Importance for IS Alignment

**Peter Haried**

School of Business Administration  
University of Wisconsin-Milwaukee  
pjharied@uwm.edu

**Keshavamurth Ramamurthy**

School of Business Administration  
University of Wisconsin-Milwaukee  
ramurthy@uwm.edu

## ABSTRACT

Achieving alignment between information systems (IS) strategy and business strategy has been a long running challenge for many organizations. IS alignment has consistently been identified as essential for achieving organizational success. However, the processes required to achieve IS alignment are often misunderstood and unclear. The informal networks within the organization may provide the link to creating the relationships and processes geared at increasing communication and planning throughout the organization that is consistently identified as essential for achieving IS alignment. The IS Alignment Network Structure Model (ISANSM) is developed to study the relationships between organizational network structures and the IS alignment process. The potential research findings may suggest that the informal network structures inherent within an organization play a significant role in achieving IS alignment and may more accurately reflect the dynamic interactions required to achieve IS alignment.

## Keywords

IS Strategy, IS Alignment, Informal and Formal Network Structures

## INTRODUCTION

As business moves further into an economy where collaboration and innovation are central to organizational success, it is essential that management pay more attention and achieve a greater understanding of the relationships that people rely on to accomplish business activities. Organizational success has often been seen to be linked to the achievement of the alignment between IS strategy and business strategy, referred to as IS alignment throughout this research (Chan, Huff, Barclay, and Copeland, 1997, Sabherwal and Chan, 2001). However, even though there is an explicit desire for realizing IS alignment, the processes for achieving such alignment are not easily or clearly understood by management (Hirschheim and Sabherwal, 2001).

Research on strategic decision making shows that executives assign greater weight to informal conversations with colleagues, in comparison to impersonal, formal information sources, when making strategic decisions (Brown and Eisenhardt, 1997; Elenkov, 1997). These essential and required relationship and communication processes suggest that the familiar saying "It's not what you know, it's who you know," represented through the informal network, may have direct implications in achieving the relationships required for realizing IS alignment. In this research, the informal network is defined briefly as the various informal structures, relationships, connections, and procedures that people use to accomplish business activities. These informal networks include the social networks, communities of practice, cross department relationships, unofficial agreed-on processes, and flexible divisions of work that are present within the organization (Chan, 2002).

Rather than treating the relationships and collaboration that occur within the informal network as an invisible unmanageable force, this research attempts to identify the informal network as a visible, manageable asset for the organization. Recent strategic decision making and IS alignment literature suggest that the informal and formal structural forms of the organization may be a significant factor in understanding IS alignment (Armstrong and Sambamurthy, 1999; Chan, 2002; Reich and Benbasat, 2000). This research addresses the gap within IS alignment literature that does not specifically address the importance of the informal network in achieving IS alignment

## IS ALIGNMENT NETWORK STRUCTURE MODEL (ISANSM)

The IS Alignment Network Structure Model (ISANSM) provides an early framework for understanding the relationship between formal and informal organizational structures and the IS alignment process. In conceptualizing the ISANSM, the classical organizational structural forms: mechanistic and organic (Burns and Stalker, 1961) are applied according to their

inherent relationships to the informal and formal network structures. It is important to note that organic and mechanistic organizational structural forms represent ends of a continuum and are not a dichotomy. No organization is perfectly organic or mechanistic and interactions between the two will occur naturally and by definition (Ambrose and Schminke, 2003).

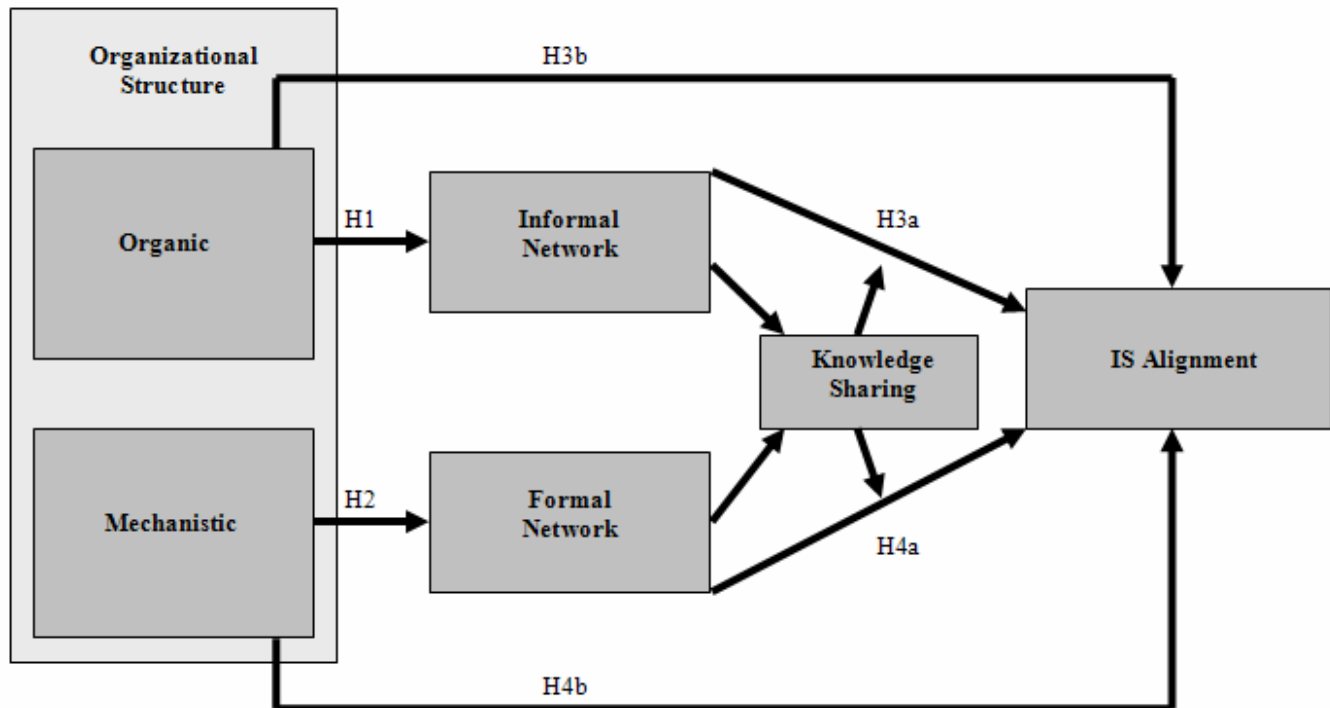

Figure 1. IS Alignment Network Structure Model (ISANSM)

### IS Alignment

The concept of IS alignment with business strategy has been widely studied in IS literature. However, precisely defining and reaching a universal definition of IS alignment has been a challenge, since alignment is not a uni-dimensional phenomenon. IS alignment has been defined as a process of achieving a fit between an organization's business strategy, information technology (IT) strategy, business infrastructure and IS infrastructure (Henderson and Venkatraman, 1993). Thus, strategic alignment is not an event, but a process of continuous adaptation and change (Henderson and Venkatraman, 1993). Additionally IS alignment has been defined as the alignment between the strategic orientations of the business unit and IS (Chan et al., 1997). Following these suggestions, the dependent variable of IS alignment is defined as the fit between an organization's business strategy and IS strategy, where fit is represented by the degree to which the IS mission, objectives and plans support and are supported by the business' objectives and plans.

### Organizational Structure

Organizational structure is defined as the recurrent set of relationships between organizational members, and is one of the most commonly seen aspects of organizations (Ambrose and Schminke, 2003). Organizational structural forms were originated and designed to match the communications needs of the organization. Organizational forms have gone through an evolution where the managerial hierarchy and divisional structures are being replaced by decentralized and more flexible approaches to coordinating activities (Daft and Lewin, 1993; Lundberg, 1994). Restructuring of organizational has resulted in de-layered organizations where the functional boundaries, coordination and work increasingly occur through informal relations, rather than the traditional hierarchical or functional formal channels (Cross, Parker, Borgatti, 2001).

#### Organic Structure

Organic organizational structures are described as flexible, loose and decentralized, and tend to be dominated by interpersonal informal network structures. Organic organizations typically consist of low degrees of formalization (in terms of specification of job duties and division of labor), open communication with significant lateral communication and few

hierarchical distinctions (Burns and Stalker, 1961). Organic structures by definition attempt to deliberately support managerial discretion, organizational adaptiveness, flexibility, open communications and a de-emphasis on formal rules and procedures (Slevin and Covin, 1997). As a result, we expect:

***H1: Organizations that are more organic in structural form will exhibit greater informal network structures.***

#### *Mechanistic Structure*

The mechanistic organizational form by definition is typically dominated by formal network structures. Such organizations are signified by high degrees of specialization and divisions of labor, a hierarchical command structure based on legitimate authority and or a routinization of job duties (Burns and Stalker, 1961). Power is often centralized and communications typically follow hierarchical channels. Mechanistic structures are typically characterized by impersonal transactions and strict adherence to formally prescribed rules and procedures (Slevin and Covin, 1997). Managerial styles and job descriptions are often uniform throughout the organization and formal rules and regulations dominate the decision making process. As a result, we expect:

***H2: Organizations that are more mechanistic in structural form will exhibit greater formal network structures.***

#### **Informal Networks**

The informal network is often described as a “subtle” and “hidden energy” that hides behind the organizational chart (Wang and Ahmed, 2003). The informal network denotes a sense of looseness and casualness to the organizational interactions people engage in everyday. The informal network, sometimes referred to as the social network, represents the emergent patterns of communication, behavior and complex webs of social ties that exist within an organization that cannot be officially represented on the formal organization chart. The informal network has also been defined to denote a friendship or familiarity of relations within an organization (Morand, 1995).

Informal networks are especially important where people routinely use personal relationships to find information to complete business activities (Cross, Nohria, and Parker, 2002). The informal network has been shown to be essential in the success of cutting-edge and innovative organizations (Kanter, 1983, 1989; Peters and Waterman, 1982), where informal networks are characterized by their ability to be highly adaptive in allowing organizational members to skip formally established structures in order to get work done.

#### **IS Alignment and the Informal Network**

Communication and relationships among business and IS executives are paramount to the IS alignment process (Armstrong and Sambamurthy, 1999; Feeny, Edwards, and Simpson, 1992; Nelson and Coopriider, 1996; Reich and Benbasat, 2000). The frequency of interaction and use of different forums for communication between CEOs and CIOs was found to positively impact a firm’s level of IS alignment (Boynton, Zmud, and Jacobs, 1994; Jarvenpaa and Ives, 1991). Richness of the communication medium has been suggested to significantly impact the effectiveness of disseminating information related to IS alignment. Face to face communication, a richer medium, resulted in a greater effectiveness of communications between CIOs and CEOs (Watson, 1990). These findings suggest that the nature of interaction between top IS management and business management significantly impact the level of IS alignment. Therefore the informal structures, which emerge rather than being mandated are gaining greater importance within organizational decision making (Chan, 2002), and may be even more influential in future decision making. These informal relationships are providing the bridge for knowledge exchange between organizational functions and departments in support of achieving IS alignment. As a result we hypothesize:

***H3a: Greater prevalence of informal network structures will significantly enhance the levels of IS alignment.***

***H3b: Organizations classified as organic organizations will exhibit significantly greater levels of IS alignment.***

#### **Formal Network**

Formal networks are characterized by the organization’s reliance on formal rules and procedures that guide the communication processes throughout the organization (Morand, 1995). Formal networks are designed to efficiently handle the standard day to day operations of the firm and represent the established and expected patterns of behavior typically exemplified in the formal organizational hierarchical chart. The organizational members’ roles and relationships are clearly defined and the members are well organized to achieve specific organizational goals. Within the IS environment, the formal network has been defined to consist of the established IS decision-making rights, reporting relationships, centralization of IS services, infrastructure, and in the deployment of IS personnel (Armstrong and Sambamurthy, 1999).

### IS Alignment and the Formal Network

The rigid bureaucracy inherent in the mechanistic and formal network structures tends to hinder information flow across functional and hierarchical units and the excessive specialization of work processes may deter the integration of expert knowledge across the organization (Cross et al. 2001). IS alignment may require a more flexible, fluid process to exchange knowledge between business functions and professionals. Chan (2002) found that IS and business professionals consistently downplayed the value of the formal network structure in achieving IS alignment, but repeatedly described critical informal network structures when discussing IS alignment.

The formality inherent in the formal network structures may limit the importance given to the formal network when describing the IS alignment process. The stringent organizational hierarchies and formal networks may also limit the ability to share knowledge between organizational units. Limited knowledge sharing resulting through the formal network could negatively impact the level of IS alignment. As a result we expect:

**H4a: Greater prevalence of formal network structures will significantly reduce the levels of IS alignment.**

**H4b: Organizations classified as mechanistic organizations will exhibit significantly lower levels of IS alignment.**

### Knowledge Sharing as a Mediator

Knowledge sharing and transfer within an organization has been suggested as being essential to create the link between IS strategy and business strategy (Armstrong and Sambamurthy, 1999; Nelson and Coopriider, 1996). Prior research shows that the properties of an organization's informal network influence the level of knowledge transfer within the organization (Borgatti and Cross, 2003; Reagans and McEvily, 2003). The social relationships inherent in the informal network may provide individuals opportunities and incentive to create, retain and transfer knowledge essential for achieving IS alignment.

### CONCLUSION

This study highlights the importance of informal networks in positioning the firm to realize IS alignment. Empirical validation of the study's model and anticipated findings may challenge IS managers to think not only in the traditional formal structures that have traditionally dominated organizational decision making, but to additionally consider the power of the hidden informal network in achieving IS alignment and examine ways in which such networks can be fostered and nurtured. IS alignment is a fluid process that may benefit from the inclusion of flexible informal network structures. In closing, this study will hopefully have increased the understanding of the linkage between IS alignment and the informal network that is growing in importance in today's de-layered business environment.

### REFERENCES

1. Ambrose, M.L. and Schminke, M. (2003) Organizational Structure as a Moderator of the Relationship Between Procedural Justice, Interactional Justice, Perceived Organizational Support and Supervisory Trust, *Journal of Applied Psychology*, 88, 2, 295-305.
2. Armstrong, C.P. and Sambamurthy, V. (1999) Information Technology Assimilation in Firms: The Influence of Senior Leadership and IT Infrastructures, *Information Systems Research*, 10, 4, 304-327.
3. Borgatti, S.P. and Cross, R. (2003) A Relational View of Information Seeking and Learning in Social Networks, *Management Science*, 49, 4, 432-445.
4. Boynton, A.C., Zmud, R.W., and Jacobs, G. (1994) The Influence of IT Management Practices on IT Use in Large Organizations, *MIS Quarterly*, 18, 229-318.
5. Brown, S.L. and Eisenhardt, K. (1997) The Art of Continuous Change: Linking Complexity Theory and Time-Paced Evolution in Relentlessly Shifting Organizations, *Administrative Science Quarterly*, 42, 1-34.
6. Burns, T. and Stalker, G.M. (1961) *The Management of Innovation*, London: Tavistock.
7. Chan, Y.E. (2002) Why Haven't We Mastered Alignment? The Importance of the Informal Organization Structure, *MIS Quarterly Executive*, 1, 2, 97-112.
8. Chan, Y.E., Huff, S., Barclay, D.W. and Copeland, D.G. (1997) Business Strategic Orientation, Information Systems Strategic Orientation, and Strategic Alignment, *Information Systems Research*, 8, 2, 125-150.

9. Cross, R., Parker, A. Prusak, L. and Borgatti, S.P. (2001) Knowing What We Know: Supporting Knowledge Creation and Sharing in Social Networks, *Organizational Dynamics*, 30, 2, 100-120.
10. Cross, R., Nohria, N. and Parker, A. (2002) Six Myths About Informal Networks – and How to Overcome Them, *MIT Sloan Management Review*, 43, 3, 67-75.
11. Daft, R.L and Lewin, A.Y. (1993) Where Are the New Organizational Forms? *Organizational Science*, 4, 4, 513-528.
12. Elenkov, D.S. (1997) Strategic Uncertainty and Environmental Scanning: The Case for Institutional Influences on Scanning Behavior, *Strategic Management Journal*, 18, 287-303.
13. Feeny, D.F., Edwards, B.R. and Simpson, K.M. (1992) Understanding the CIO/CEO Relationship, *MIS Quarterly*, December, 435-448.
14. Henderson, J.C. and Venkatraman, N. (1993) Strategic Alignment: Leveraging Information Technology for Transforming Organizations, *IBM Systems Journal*, 38, 2&3, 472-484.
15. Hirschheim, R. and Sabherwal, R. (2001) Detours in the Path to Strategic Information Systems Alignment, *California Management Review*, 44, 1, 87-108.
16. Jarvenpaa, S.L. and Ives, B. (1991) Executive Involvement and Participation in the Management of Information Technology, *MIS Quarterly*, 15, 205-227.
17. Kanter, R.M. (1983) *The Change Masters*, New York: Simon and Schuster.
18. Kanter, R.M. (1989) *When Giants Learn to Dance*, New York: Simon and Schuster.
19. Luftman, J. (2003) Assessing IT/Business Alignment, *Information Systems Management*, Fall, 9-15.
20. Lundberg, C.C. (1994) Toward Managerial Artistry: Appreciating and Designing Organizations for the Future, *International Journal of Public Administration*, 17, 3 and 4, 659-674.
21. Morand, D.A. (1995) The Role of Behavioral Formality and Informality in the Enactment of Bureaucratic Versus Organic Organizations, *Academy of Management Review*, 20, 4, 831-872.
22. Nelson, K.M. and Coopridge, J.G. (1996) The Contribution of Shared Knowledge to IS Group Performance, *MIS Quarterly*, December, 409-432.
23. Peters, T.J. and Waterman, R.H. Jr., (1982) *In Search of Excellence*, New York: Harper & Row.
24. Reagans, R. and McEvily, B. (2003) Network Structure and Knowledge Transfer: The Effects of Cohesion and Range, *Administrative Science Quarterly*, 48, 240-267.
25. Reich, B.H. and Benbasat, I. (1996) Measuring the Linkage Between Business and Information Technology Objectives, *MIS Quarterly*, March, 55-81.
26. Reich, B.H. and Benbasat, I. (2000) Structures That Influence the Social Dimension of Alignment between Business and Information Technology Objectives, *MIS Quarterly*, 24, 1, 81-113.
27. Sabherwal, R. and Chan, Y. E. (2001) Alignment Between Business and IS Strategies: A Study of Prospectors, Analyzers, and Defenders, *Information Systems Research*, 12, 1, 11-33.
28. Slevin, D.P. and Covin, J.G. (1997) Strategy Formulation Patterns, Performance, and the Significance of Context, *Journal of Management*, 23, 2, 189-209.
29. Wang, C.L. and Ahmed, P.K. (2003) Structure and Structural Dimensions for Knowledge-based Organizations, *Measuring Business Excellence*, 7, 1, 51-62.
30. Watson, R.T. (1990) Influences on the IS Manager's Perceptions of Key Issues: Information Scanning and the Relationship with the CEO, *MIS Quarterly*, June, 217-231.