

2011-9

The Effects of Interface Protection Requirements on the Stability of Embedded Generation Connected to the Irish Distribution System

Damien Glennon
Technological University Dublin

Follow this and additional works at: <https://arrow.tudublin.ie/engscheledismsc>



Part of the [Electrical and Computer Engineering Commons](#)

Recommended Citation

Glennon, D.: The Effects of Interface Protection Requirements on the Stability of Embedded Generation Connected to the Irish Distribution System. Masters Thesis. Technological University Dublin, 2011.

This Theses, Masters is brought to you for free and open access by the Dissertations at ARROW@TU Dublin. It has been accepted for inclusion in Msc. in Energy Management by an authorized administrator of ARROW@TU Dublin. For more information, please contact yvonne.desmond@tudublin.ie, arrow.admin@tudublin.ie, brian.widdis@tudublin.ie.



This work is licensed under a [Creative Commons Attribution-Noncommercial-Share Alike 3.0 License](#)



The Effects of Interface Protection Requirements on the Stability of Embedded Generation Connected to the Irish Distribution System

A thesis submitted to Dublin Institute of Technology in part fulfilment of the requirements for award of Masters (MSc) in Energy Management

By

Damien Glennon

September 2011

Supervisor: Fintan McLoughlin

School of Electrical Engineering Systems

Declaration

I certify that this thesis which I now submit for examination for the award of MSc in Energy Management, is entirely my own work and has not been taken from the work of others, save and to the extent that such work has been cited and acknowledged within the text of my work.

This thesis was prepared according to the regulations for postgraduate study by research of the Dublin Institute of Technology and has not been submitted in whole or in part for another award in any Institute.

The work reported on in this thesis conforms to the principles and requirements of the Institute's guidelines for ethics in research.

The Institute has permission to keep, lend or copy this thesis in whole or in part, on condition that any such use of the material of the thesis be duly acknowledged.

Signature _____ Date _____
Candidate

Abstract

The electricity sector in Ireland has undergone a number of changes in the last 20 years. In the early 90's the fuel mix was predominantly fossil fuel based with a very small percentage of renewables on the system. The electricity generation portfolio was dominated by coal/gas/peat fired power stations which used large synchronous machines to generate electricity. These synchronous machines provided the necessary system inertia and kept the system frequency stable. However, rising fuel costs, dwindling fossil fuel supplies, climate change etc. has driven the growth of renewable energy especially in the electricity sector. Current targets for renewable energy in the electricity sector are set at 40% by 2020. This is outlined in detail in the RES-E targets.

As of July 2011, approximately 1700MW of renewable generation capacity was connected to the Irish power system with wind been the largest contributor. Furthermore, in April 2011 wind generation output reached 1323MW. With current projections indicating somewhere between 3000-5000MW of wind energy on the system by 2020, serious concerns are beginning to be raised especially in the area of system stability.

With the percentage of electricity generated from wind turbines increasing, it is vital to ensure that this wind generation is not needlessly disconnected from the system. This project focuses on the interface protection requirements to determine if a loosing of the protection requirements could aid system stability. The project will also look at international practice in regards to interface protection requirements with a view to determining if certain international practices could be adopted on the Irish power system. This project will focus mainly on the Doubly Fed Induction Generator wind turbine as this is the predominant turbine on the system. This project will be carried out in PSS/E simulation software.

Acknowledgements

I would like to thank Danijela Klopotan and Laura Martinez for their help and guidance especially in the areas of PSS/E and dynamic simulation. I would also like to acknowledge the work carried out by Fergus Malone and Ken Atkinson in regards to interface protection requirements for embedded generation connecting to the distribution system.

Finally, I would like to thank Fintan McLoughlin for his guidance over the course of this project.

Table of Contents

1	Introduction	2
1.1	Overview	2
1.2	Problem Definition and Motivation	2
1.3	Aims and Objectives	4
1.4	Approach	4
1.5	Scope of Thesis	6
2	Embedded Generation Technology	8
2.1	Introduction to Embedded Generation in Ireland	8
2.2	Types of Embedded Generation	11
2.2.1	Hydro Generation	11
2.2.2	Landfill Gas	11
2.2.3	Wind Generation	11
2.3	Embedded Generation Technology	12
2.3.1	Synchronous Generators	12
2.3.2	Induction Generators	13
2.4	Wind Generation Technology	14
2.4.1	Doubly Fed Induction Generators	14
2.4.2	Fixed Speed Induction Generators	15
2.4.3	Inverter Interfaced Induction Generators	17
2.5	Integration of Embedded Generation into the Irish Power System	18
3	Interface Protection	21
3.1	Introduction to Interface Protection	21
3.2	Interface Protection Requirements	22
3.2.1	Frequency Protection Requirements	22
3.2.2	Voltage Protection Requirements	29
3.2.3	Overcurrent Protection Requirements	36
3.2.4	Earth Fault Protection Requirements	40
3.2.5	Loss of Mains Protection Requirements	43
4	Approach and Methodology	53
4.1	PSS/E Simulation Software	53
4.1.1	PSS/E Wind Turbine Model	54
4.1.2	Generator/Convertor Model (WT3G1)	55

4.1.3	Electrical Control Model (WT3E1)	56
4.1.4	Dynamic Model of the Infinite Grid	57
4.1.5	Voltage & Frequency Relay	57
4.2	Project Structure	57
4.3	Test Distribution System	58
4.3.1	Test Distribution System – 110kV Equivalent Impedance	58
4.3.2	Test Distribution System – 38kV Network	59
4.3.3	Test Distribution System – 38kV Wind Farm	59
4.3.4	Test Distribution System – System Loading	59
4.3.5	Protection Relays	60
4.3.6	Dynamic Model Setup PSS/E	60
4.4	Conditions for Analysis	60
4.5	Methodology	61
4.5.1	Fault Analysis	61
4.5.2	Loss of Mains Analysis	62
5	Results and Discussion.....	64
5.1	Assumptions	64
5.2	Simulation of Scenarios	65
5.2.1	110kV Fault Simulation	65
5.2.2	38kV Fault Simulation	65
5.2.3	Loss of Mains Events	66
5.3	Power Flow Results	66
5.4	Fault Simulation Results – 110kV Faults	67
5.4.1	Summer Night Valley Results	67
5.4.2	Winter Peak Results	68
5.5	Fault Simulation Results – 38kV Faults	68
5.5.1	Summer Night Valley Results	68
5.5.2	Winter Peak Results	70
5.6	Loss of Mains Analysis	72
5.6.1	Loss of 110/38kV Substation	72
5.6.2	Loss of 110/38kV Substation + 38kV Feeder (B – C)	74
5.6.3	Loss of 110/38kV Substation + 38kV Feeder (38kV Node – B)	76
5.6.4	Loss of 110/38kV Substation + 38kV Feeder (38kV Node – D)	78
5.6.5	Loss of 110/38kV substation + 38kV feeder (38kV Node – F)	80

5.6.6	Loss of 110/38kV substation + 38kV feeder (D – E)	82
5.6.7	Loss of 110/38kV substation + 38kV feeder (F – Wind farm)	84
5.7	Findings	86
6	Conclusion.....	89
6.1	Conclusions	89
6.2	Future Work	91
	References.....	92
	Appendix.....	96
A	PSS/E Wind Turbine Model Documentation	96
B	PSS/E Generator Turbine Model Documentation	107
C	Single Line Diagrams	111
D	Wind Farm Technical Data	115
E	38kV Distribution System Technical Data	121
F	Power Flow Results	127
G	ESB Networks Interface Protection Requirement	136
H	Irish Power System Data	139
I	Dynamic Results	142
J	PSS/E Relay Documentation	215
K	ROCOF Protection Operation	218

List of Figures

- Figure 2.1: Installed Wind Generating Capacity 2000 – 2009 [31]
- Figure 2.2: Indicative Trajectory of Wind Capacity connected to the Irish Power System
- Figure 2.3: DFIG Wind Turbine System [25]
- Figure 2.4: Direction Connection of Fixed-Speed Induction Generator to the Grid [33]
- Figure 2.5: Full Converter Wind Turbine [26]
- Figure 2.6: Renewable Capacity in Ireland 2010 – 2020 [4]
- Figure 3.1: Frequency Limits – Distribution Code [11]
- Figure 3.2: Frequency Requirements – Distribution Code [11]
- Figure 3.3: Fault Ride Through Capability for Types B, C, D and E Wind Farm Power Stations Connected to the Distribution System [11]
- Figure 3.4: Fault Ride Through Capability for Types A Wind Farm Power Stations Connected to the Distribution System [11]
- Figure 3.5: Fault Ride Through Capability for Types B, C, D and E Wind Farm Power Stations Connected to the Distribution System [11]
- Figure 3.6: Fault Ride Through Capability for Types A Wind Farm Power Stations Connected to the Distribution System [11]
- Figure 3.7: Operating Voltage Limits [11]
- Figure 4.1: Wind Turbine Dynamic module

List of Tables

- Table 2.1: Fuels used in electricity generation 1990 – 2008 [15]
- Table 2.2: Renewables Electricity Generated 1990 – 2008 [15]
- Table 3.1: Irish Frequency Protection Settings for Embedded Generator Installations [9]
- Table 3.2: Irish Frequency Protection Settings for Embedded Generator Installations (Wind) [9]
- Table 3.3: Danish Frequency Protection Settings for Embedded Generator Installations [34], [24], [35]
- Table 3.4: Finnish Frequency Protection Settings for Embedded Generator Installations
- Table 3.5: French Frequency Protection Settings for Embedded Generator Installations
- Table 3.6: German Frequency Protection Settings for Embedded Generator Installations
- Table 3.7: Norwegian Frequency Protection Settings for Embedded Generator Installations
- Table 3.8: Portuguese Frequency Protection Settings for Embedded Generator Installations
- Table 3.9: Spanish Frequency Protection Settings for Embedded Generator Installations
- Table 3.10: UK Frequency Protection Settings for Embedded Generator Installations
- Table 3.11: Proposed Frequency Protection Settings for Embedded Generator Installations
- Table 3.12: Irish Voltage Protection Settings for Embedded Generator Installations
- Table 3.13: Irish Voltage Protection Settings for Embedded Generator Installations (Wind)
- Table 3.14: Danish Voltage Protection Settings for Embedded Generator Installations
- Table 3.15: Finnish Voltage Protection Settings for Embedded Generator Installations
- Table 3.16: French Voltage Protection Settings for Embedded Generator Installations

- Table 3.17: German Voltage Protection Settings for Embedded Generator Installations
- Table 3.18: Norwegian Voltage Protection Settings for Embedded Generator Installations
- Table 3.19: Portuguese Voltage Protection Settings for Embedded Generator Installations
- Table 3.20: Spanish Voltage Protection Settings for Embedded Generator Installations
- Table 3.21: UK Voltage Protection Settings for Embedded Generator Installations
- Table 3.22: Proposed Voltage Protection Settings for Embedded Generator Installations
- Table 3.23: Irish Overcurrent Protection Settings for Embedded Generator Installations
- Table 3.24: Danish Overcurrent Protection Settings for Embedded Generator Installations
- Table 3.25: Portuguese Overcurrent Protection Settings for Embedded Generator Installations
- Table 3.26: Irish Earth Fault Protection Settings for Embedded Generator Installations
- Table 3.27: Danish Earth Fault Protection Settings for Embedded Generator Installations
- Table 3.28: French Earth Fault Protection Settings for Embedded Generator Installations (RTE)
- Table 3.29: Earth Fault Protection Settings for Embedded Generator Installations (eRDF)
- Table 3.30: Portuguese Earth Fault Protection Settings for Embedded Generator Installations
- Table 3.31: Spanish Earth Fault Protection Settings for Embedded Generator Installations
- Table 3.32: UK Earth Fault Protection Settings for Embedded Generator Installations
- Table 3.33: Irish Loss of Mains Protection Settings for Embedded Generator Installations

Table 3.34:	Irish Loss of Mains Protection Settings for Embedded Generator Installations (Wind)
Table 3.35:	Danish Loss of Mains Protection Settings for Embedded Generator Installations
Table 3.36:	German Loss of Mains Protection Settings for Embedded Generator Installations
Table 3.37:	Proposed Loss of Mains Protection Settings for Embedded Generator Installations
Table 4.1:	Relay Pickup Time
Table 4.2:	110kV System Faults
Table 4.3:	38kV System Faults
Table 5.1:	110kV System Faults - Line to Line Fault – SNV
Table 5.2:	110kV System Faults – Single Line to Ground Fault - SNV
Table 5.3:	110kV System Faults - Line to Line Fault - WP
Table 5.4:	110kV System Faults – Single Line to Ground Fault - WP
Table 5.5:	38kV System Faults – 15% Output - SNV
Table 5.6:	38kV System Faults - 100% Output –SNV
Table 5.7:	38kV System Faults – 15% Output - WP
Table 5.8:	38kV System Faults - 100% Output - WP
Table 5.9:	Loss of 110kV Substation– 15% Output - SNV
Table 5.10:	Loss of 110kV Substation– 100% Output - SNV
Table 5.11:	Loss of 110kV Substation– 15% Output - WP
Table 5.12:	Loss of 110kV Substation– 100% Output - WP
Table 5.13:	Loss of 110kV Substation + Feeder B - C – 15% Output - SNV
Table 5.14:	Loss of 110kV Substation + Feeder B - C – 100% Output - SNV
Table 5.15:	Loss of 110kV Substation + Feeder B - C – 15% Output - WP
Table 5.16:	Loss of 110kV Substation + Feeder B - C – 100% Output - WP
Table 5.17:	Loss of 110kV Substation + Feeder B – 15% Output - SNV
Table 5.18:	Loss of 110kV Substation + Feeder B – 100% Output - SNV
Table 5.19:	Loss of 110kV Substation + Feeder B – 15% Output - WP
Table 5.20:	Loss of 110kV Substation + Feeder B – 100% Output - WP
Table 5.21:	Loss of 110kV Substation + Feeder D – 15% Output - SNV
Table 5.22:	Loss of 110kV Substation + Feeder D – 100% Output - SNV
Table 5.23:	Loss of 110kV Substation + Feeder D – 15% Output - WP

- Table 5.24: Loss of 110kV Substation + Feeder D – 100% Output - WP
- Table 5.25: Loss of 110kV Substation + Feeder F – 15% Output - SNV
- Table 5.26: Loss of 110kV Substation + Feeder F – 100% Output - SNV
- Table 5.27: Loss of 110kV Substation + Feeder F – 15% Output - WP
- Table 5.28: Loss of 110kV Substation + Feeder F – 100% Output - WP
- Table 5.29: Loss of 110kV Substation + Feeder D – E – 15% Output - SNV
- Table 5.30: Loss of 110kV Substation + Feeder D – E – 100% Output - SNV
- Table 5.31: Loss of 110kV Substation + Feeder D – E – 15% Output - WP
- Table 5.32: Loss of 110kV Substation + Feeder D – E – 100% Output - WP
- Table 5.33: Loss of 110kV Substation + Feeder F – Wind farm – 15% Output - SNV
- Table 5.34: Loss of 110kV Substation + Feeder F – Wind farm – 100% Output - SNV
- Table 5.35: Loss of 110kV Substation + Feeder F – Wind farm – 15% Output – WP
- Table 5.36: Loss of 110kV Substation + Feeder F – Wind farm – 100% Output – WP
- Table 5.37: Recommended Frequency Protection Settings for Embedded Generator Installations
- Table 5.38: Recommended Voltage Protection Settings for Embedded Generator Installations
- Table 5.39: Recommended Irish Overcurrent Protection Settings for Embedded Generator Installations
- Table 5.40: Recommended Irish Earth Fault Protection Settings for Embedded Generator Installations
- Table 5.41: Recommended Loss of Mains Protection Settings for Embedded Generator Installations

List of Acronyms

CHP:	Combined Heat and Power
DFIG:	Doubly Fed Induction Generators
DNO:	Distribution Network Operator
DSO:	Distribution System Operator
EG:	Embedded Generation
ESB:	Electricity Supply Board
ESBI:	ESB International
ESBN:	ESB Networks
entsoe:	European network of transmission system operators for electricity
eRDF:	Électricité Réseau Distribution France
FACT:	Flexible AC Transmission
FSIG:	Fixed Speed Induction Generator
GPS:	Global Positioning Satellite
IGBT:	Insulated Gate Bipolar Transistor
IIEG:	Inverter Interfaced Embedded Generator
IPP:	Independent Power Provider
KW:	Kilo Watt
LOM:	Loss of Mains
MEC:	Maximum Export Capacity
MW:	Mega Watt
NVD:	Neutral Voltage Displacement
PAD:	Phase Angle Difference
PCC:	Point of Common Coupling
PES:	Public Electricity supplier
PLL:	Phase Locked Loop
PMU:	Phasor Measurement Unit
PSSE:	Power System Simulator/Engineering
PTI:	Power Technologies International
PWM:	Pulse Width Modulation
ROCOF:	Rate of Change of Frequency
RTE:	Réseau de Transport d'Électricité
SI:	Statutory Instrument

SNV:	Summer Night Valley
SVC:	Static Var Compensation
TSO:	Transmission System Operator
UCTE:	Union for the Coordination of the Transmission of Electricity
VS:	Vector Shift
WP:	Winter Peak
YEDL:	Yorkshire Electricity Distribution Limited

List of Appendices

- A: PSS/E Wind Turbine Model Documentation
- B: PSS/E Generator Turbine Model Documentation
- C: Single Line Diagrams
- D: Wind Farm Technical Data
- E: 38kV Distribution System Technical Data
- F: Power Flow Results
- G: ESB Networks Interface Protection Requirement
- H: Irish Power System Data
- I: Dynamic Results
- J: PSS/E Relay Documentation
- K: ROCOF Protection Operation

Chapter 1

Introduction

1 Introduction

1.1 Overview

Over the last 20 years, the world has been faced with a number of challenges in the areas of energy, economics and the environment. From both an energy and economic perspective, it can be observed that from 1985 to approximately September 2003, the inflation-adjusted price of a barrel of crude oil was under \$25/barrel (excluding intermittent spikes). However, during 2003, the price rose above \$30/barrel and by August 2005 reached \$60/barrel and peaked at a \$147/barrel in July 2008. These price increases can be attributed to the decline in petroleum reserves, peak oil fears, energy speculation as well as tension in the Middle East. While the price of fuel has reduced some what due to global economic recession, the fact of the matter remains that fossil fuels are running out and what ever remaining fuel stock exist will become more and more expensive.

From an environmental perspective, it can be observed that over the last 20 years there has been a major push to tackle climate change on both a national and international level. Some international scientists fear that if nothing is done to tackle climate change, irreversible damage will be done to the environment. Environmental effects include rising global temperatures, melting of the ice caps, rising sea levels and more extreme weather.

It is these aforementioned issues which have driven the growth in renewable energy on a global scale. In Ireland, it is envisaged that by 2020, 40% of electricity consumption will be from renewable sources which include wind, hydro, landfill and wave. With somewhere between 3000 – 5000MW of renewable energy connecting to the Irish power system over the next 10 years, serious concerns are been raised by both of the system operators (transmission/distribution).

1.2 Problem Definition and Motivation

The connection of significant amounts of wind generation to the power system brings a number of technical challenges in terms of system stability and power system protection. For both the Transmission System Operator (TSO) and the Distribution System Operator (DSO), the area of power system stability is a significant issue. With the generating portfolio shifting from one composed of large synchronous machines

(ranging from 100-500MW in size) to a mix of large synchronous machines and large quantities of smaller Induction Machines (ranging from 1-3MW in size) which are in turn embedded in the power system, the TSO/DSO is now faced with potential voltage and frequency stability issues. This is primarily due to the fact that wind turbines (induction machines) are limited by the voltage and frequency support which they can provide to the system. The other issue associated with Embedded Generation (EG) is power system protection. In the event of a fault on the power system, it is necessary to ensure that embedded generation is disconnected in a fast, safe and secure manner. This is a legal obligation which the TSO/DSO must discharge. Both the TSO and the DSO outline protection requirements for embedded generators which must be implemented by the EG. The interface protection specified by the TSO/DSO includes Voltage, Frequency and Loss of Mains (LOM) requirements. In particular the LOM requirement has had the biggest effect on power system stability. The most popular forms of LOM protection on the Irish system are Rate of Change of Frequency (ROCOF) and Vector Shift with the ROCOF relay been the most popular. Both the ROCOF and Vector Shift relays are considered to be extremely sensitive and there are numerous cases of spurious operation of both devices on both a national and international level. In the past, the spurious operation of LOM protection would not have been an issue due to the fact that there were relatively low levels of embedded generation on the system. With more and more embedded generation connected to the transmission and distribution system, it is essential to ensure that embedded generation is not needlessly disconnected from the power system. It is very important to ensure interface protection requirements reflect the changing nature of turbine technology. The original interface protection requirements were devised primarily for synchronous generator technology. With turbine technology constantly changing as well as the introduction of new technologies, it is critical to ensure that interface protection requirements can meet the requirements of safe, secure and reliable operation. It is these requirements which will be looked at in greater detail in the thesis with a view to modifying existing requirements to improve power system performance and stability.

1.3 Aims and Objectives

The aim of this thesis is to conduct a power system analysis using PSS/E simulation software to evaluate the impact of existing interface protection requirements on the stability of wind farms. Based on the outcomes of the power system analysis, appropriate changes to existing interface protection requirements will be proposed.

1.4 Approach

The thesis is composed of four main components which are as follows:

- Review of Embedded Generation Technology (Chapter 2)
- Review of Interface Protection Requirements (Chapter 3)
- Development and Testing of the Test Network in PSS/E (Chapter 4)
- Review of Findings (Chapter 5)

Chapter 2 contains an introduction to embedded generation in Ireland. This includes looking at the past, present as well as the predicted growth of embedded generation in Ireland over the next 10 years. This introduction is followed by a review of the different types of embedded generation currently installed on the Irish system (Wind, Hydro, and Landfill Gas) outlining total installed capacity to date and percentage share of each technology to the renewable mix in Ireland. Furthermore, this chapter looks at the generator technology (Synchronous/Asynchronous Generator) involved outlining how each technology operates along with perceived advantages and disadvantages. This chapter then focuses on wind generation technology namely the Doubly Fed Induction Generator, the Fixed Speed Induction Generator and the Inverter Interfaced induction Generator. The advantages and disadvantages of each of the wind turbine generators are also quantified. Finally, this chapter ends with a review of the integration of embedded generation into the Irish System. The goal of this chapter is to put into perspective the rapid growth of embedded generation in Ireland over the last decade and to highlight the challenges associated with the integration of large amounts of embedded generation of different technologies into the Irish power system.

Chapter 3 contains an introduction to interface protection requirements in Ireland. This chapter outlines the history of interface protection requirements in Ireland

spanning the last twenty years. Furthermore, this chapter quantifies the importance of interface protection at embedded generation sites especially for the distribution system operator. This chapter focuses on five main interface protection requirements which are voltage, frequency, overcurrent, earth fault and loss of mains. Each of the aforementioned protection requirements are compared with the protection requirements of Denmark, Finland, France, Germany, Norway, Portugal, Spain and the United Kingdom. This chapter also highlights the incompatibility of existing interface protection requirements with distribution code requirements namely frequency and fault ride through requirements. On comparison of international practice with Irish requirements, proposals are put forward to modify existing Irish Interface protection requirements especially for voltage, frequency and loss of mains requirements. This chapter is of major importance as the proposed settings derived were then tested in the PSS/E test network.

Chapter 4 outlines the approach and methodology taken in the thesis. This chapter discusses the simulation software (PSS/E) used to create the test model of the distribution system. This chapter looks at the PSS/E wind turbine model used as part of this thesis and how the various components interact. This chapter also looks at the dynamic modelling of the infinite grid along with the implementation of voltage and frequency protection in PSSE. This chapter outlines the steps taken to develop the test network, network components used and the number of test models created as well as system loading and generation dispatches. This chapter goes on to outline the three main scenarios to be tested which were 110kV fault simulation, 38kV fault simulation and loss of mains events along with fault duration for each of the aforementioned scenarios.

Chapter 5 outlines the assumptions made as part of the thesis along with the results obtained from the simulation software. This chapter outlines the simulation of scenarios, the results of the power flow studies, the results of the fault studies followed by the results of the loss of mains analysis. In this chapter, the performance of existing interface protection requirements are compared and contrasted with the proposed interface protection requirements outlined in Chapter 3 of the thesis. Finally this chapter ends with a discussion on the findings of the dynamics studies followed by a summary outlining the newly proposed interface protection requirements.

1.5 Scope of Thesis

Chapter 2 starts with a general overview of embedded generation in Ireland. The chapter outlines the growth of generation in Ireland over the last 20 years and the expected growth over the next 10 years. The chapter goes on to look at the different types of embedded generation (Wind, Hydro, Landfill etc.), embedded generation technologies involved and highlights the technical challenges associated with induction generator technology.

Chapter 3 looks at the Irish distribution code and interface protection requirements. The chapter goes on to compare Irish requirements with international interface protection requirements and proposes changes to the Irish interface protection requirements. The chapter also looks at the issues associated with loss of mains protection namely ROCOF and Vector Shift.

Chapter 4 outlines the approach and methodology for the thesis. This chapter looks at the simulation software utilised and the test model created for the purpose of testing the interface protection requirements. All major parts of the test model are described in this chapter. The chapter goes on to look at the scenarios to be tested and outlines the main areas of concern.

Chapter 5 defines the scenarios tested and discusses the results obtained from the power system studies.

Chapter 6 summarises the conclusions of the thesis and outlines future work.

Chapter 2

Embedded Generation Technology

2 Embedded Generation Technology

2.1 Introduction to Embedded Generation in Ireland

Over the last 20 years, Ireland has experienced a significant growth in the amount of renewable generation connected to the Irish power system. This is largely due to rising fuel prices, dwindling fossil fuel reserves and a growing urgency to tackle climate change. As a nation, Ireland imports over 90% [15] of its energy needs. This heavy dependency on energy imports has left Ireland very susceptible to rising fuel prices. It is both the economic ramifications of rising energy prices and the growing urgency to tackle climate change at both a national and international level which has resulted in significant growth in renewable energy in Ireland.

Table 2.1 show the growth of renewables in the electricity sector over the last 20 years. It can be observed that between 1990 and 2008, the share of renewables used in electricity generation grew from 1.9% to 6.4%. This can be contributed to the ambitious targets set out for renewables on both a national level (The White Paper 2007 [21]) and European level (RES-e directive 2009/28/EC [10]). On a national level, Ireland has committed to an ambitious target of 40% of electricity consumption from renewable by 2020 while on a European level Ireland has committed to a legally binding target of 16% of total energy consumption to be generated from renewable energy by 2020.

	Fuels used in electricity generation (ktoe)							Share %	
	1990	1995	2000	2005	2006	2007	2008	1990	2008
Coal	1,245	1,499	1,430	1,416	1,265	1,124	1,046	40.3	20.4
Peat	604	574	491	511	444	438	566	19.5	11.0
Oil	341	625	1,039	774	693	404	351	11.0	6.8
Natural Gas	843	1,063	1,828	2,044	2,417	2,737	2,811	27.3	54.7
Renewables	60	63	117	180	232	258	329	1.9	6.4
Electricity Imports	0	-1	8	176	153	114	39	0.0	0.8
Total	3,093	3,822	4,914	5,101	5,205	5,075	5,141		

Table 2.1: Fuels used in electricity generation 1990 – 2008 [15]

Table 2.2 shows a breakdown of the electricity produced by renewable energy. It can be observed that wind energy accounted for 68.1% of the electricity generated by renewables in 2008.

	Renewables electricity generated (GWh)							Share %	
	1990	1995	2000	2005	2006	2007	2008	1990	2008
Hydro	697	713	847	631	724	667	968	100.0	27.4
Wind	0	16	244	1,112	1,622	1,958	2,410	0.0	68.1
Solid Biomass	0	0	0	8	8	14	33	0.0	0.9
Landfill Gas	0	0	95	106	108	102	111	0.0	3.1
Biogas	0	0	0	16	12	17	17	0.0	0.5
Total	697	729	1,186	1,873	2,475	2,758	3,539		
Share of GEC	4.9%	4.1%	5.0%	6.8%	8.6%	9.4%	11.9%		

Table 2.2: Renewables Electricity Generated 1990 – 2008 [15]

From Table 2.2 above, it is clear that the predominant form of renewable generation connected to the power system is wind energy. Figure 2.1 shows the growth in wind capacity in Mega Watts over the last 10 years. It can be seen from the graph that the total wind capacity in Ireland has grown by over 1,000MW in the last 10 years.

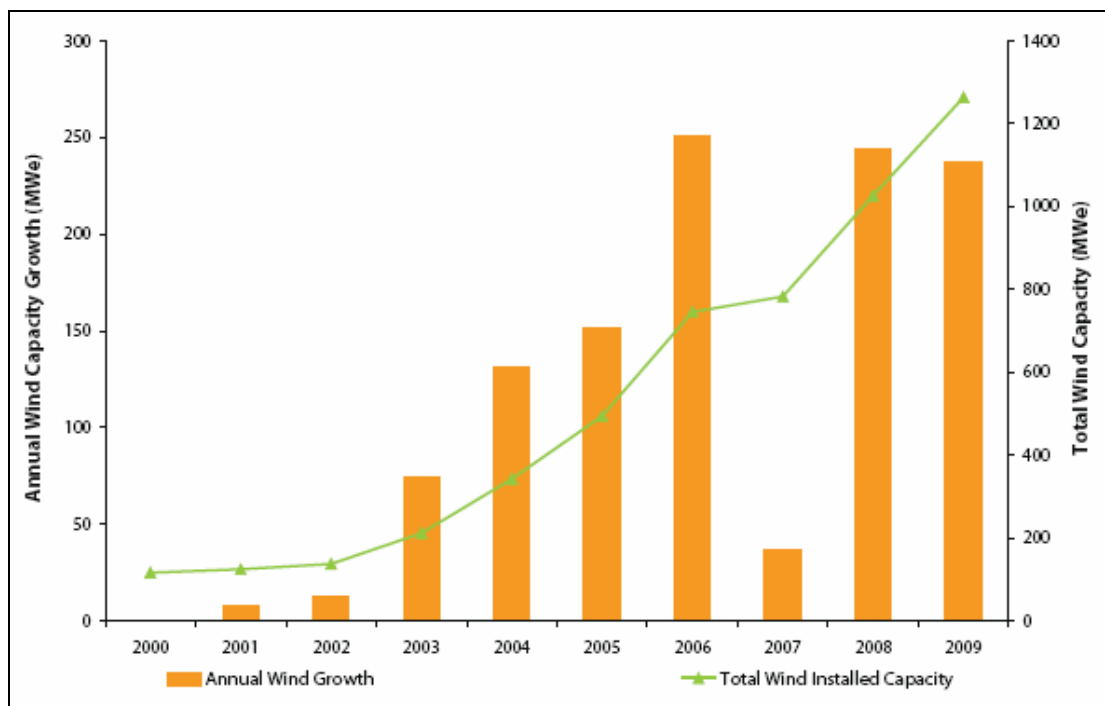

Figure 2.1: Installed Wind Generating Capacity 2000 – 2009 [31]

As of January 2011, 1741MW [13] of renewable capacity was installed on the Irish power system. Considering that the maximum system load for 2010 was 5,090MW and the minimum system load was 1,597MW and that the installed capacity of renewable energy is 1,741MW, renewable energy has reached the point where it can have a significant impact on power system performance. This was observed on the 12th of February 2011 where the total electricity generated by wind energy reached

1,248MW at 7pm which contributed to approximately 33% of total system demand at that moment in time. This also meant that 1,248MW of fossil fuel based energy was not required on the power system which has advantages in terms of CO₂ production. However, this figure was surpassed on the 4th of April 2011 when the percentage wind contribution to total system demand reached almost 50% (see Appendix H).

According to projections made by EirGrid in the Annual Renewable Report (2010) [5], 37% of renewable electricity consumption will be from wind energy. This figure is based on a 31% wind power capacity factor. This means that approximately 4,500-5,000MW of wind energy would have to be connected to the Irish power system by 2020. Figure 2.2 shows an indicative trajectory of the amount of wind generation which will have to be connected to the Irish power system by 2020 to meet our National/European obligations. The graph shows that Ireland will have to treble its existing total installed capacity of wind generation by 2020 in order to achieve its renewable objectives. This is a significant undertaking especially in the context of a worldwide economic recession.

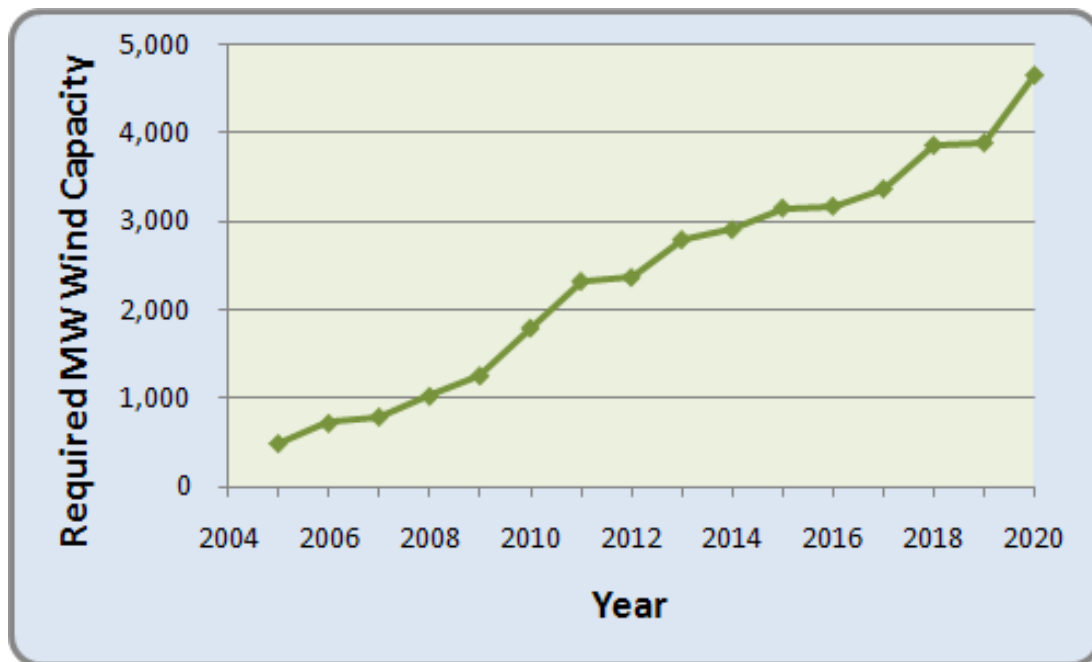

Figure 2.2: Indicative Trajectory of Wind Capacity connected to the Irish Power System

2.2 Types of Embedded Generation

The main forms of embedded generation in Ireland are Hydro, Wind, Solid Biomass, Landfill Gas and Biogas. In the early 90's, hydro generation accounted for 100% of the electricity generated by renewable energy. However, the percentage share of Hydro has shrunk significantly with the growth of wind energy. As of 2008, wind energy accounted for 68.1% of the renewable electricity generated with landfill gas (3.1%), Biogas (0.5%) and solid Biomass (0.9%) making up the balance.

2.2.1 Hydro Generation

At present there are a total of 14 hydroelectric generators connected to the Irish power system. The combined output of all hydro plant connected to the Irish system is approximately 212 MW. This equates to approximately 2.8% of the total connected generation capacity on the Irish system. In terms of micro hydroelectric generators (< 1 MW), approximately 52 plants are connected to the Irish distribution system with a total installed capacity of 25.1 MW. As a final point, there are a total of 6 micro generation projects equating to 11MW in capacity contracted for connection to the distribution system.

2.2.2 Landfill Gas

Currently, landfill gas is only utilised in Ireland for the purposes of electricity generation. Presently there are a total of 15 landfill gas generators connected to the distribution system with a combined MEC of 35.8 MW. It should also be noted that a further 2.6 MW is contracted and 16.2 MW of capacity requesting connection outside of the Gate 3 process. Finally, landfill gas is not likely to experience significant growth as a source of energy primarily due to constraints on the volume of waste that can be sent to landfills.

2.2.3 Wind Generation

Over the last decade, the amount of wind generation connecting to the transmission and distribution system has grown spectacularly. This can be observed in figures released in 2009 which saw the total output from wind generation reach 2,955 gigawatt hours (GWh). This represented an overall increase of 23% on figures from 2008, which was also the same increase as seen between 2007 and 2008. It should also be noted that wind generation accounted for approximately 10.5% of the gross electrical consumption seen in 2009 (8.1% of gross electrical consumption in 2008).

The surge in wind farm construction activity in the period 2003 – 2006 resulted in Ireland reaching the highest level of wind power penetration in the world. While Ireland has a total installed wind capacity which is low compared to countries like Denmark, Spain and Germany, the penetration of wind power is actually higher in the Irish power system than in the UCTE, British or NORDEL power systems. There was a substantial slowdown in the development of wind farms in 2007, however, in 2008 and 2009 the rate of wind farm development increased again. The total wind generation capacity reached approximately 1,264 MW by January 2010.

2.3 Embedded Generation Technology

Various technologies are used for generating electricity from other forms of energy.

These generation technologies usually take one of the following forms:

- Rotating Machines connected to Synchronous Generators
- Rotating Machines connected to Induction Machines

2.3.1 Synchronous Generators

Three phase Synchronous Generators are the primary source of all electrical energy produced and are commonly used to convert the mechanical power output of steam turbines, gas turbines, hydro turbines and wind turbines into electrical power. Synchronous generators are known as synchronous generators due to the fact that they operate at synchronous speed. This means that the speed of the rotor (with a constant magnetic field) always matches the supply frequency of the stationary winding. It should be noted that the constant magnetic field of the rotor can be produced either by the persistent magnetic field of a rotor permanent magnet assembly or by controlling direct current (dc) to a rotor field winding (i.e., electromagnet) fed through a slip-ring assembly or via some other brushless means.

Synchronous generators can generate both active and reactive power independently and can play an important role in voltage control.

In comparison to an induction generator, the synchronous generator is both more expensive and more complexed mechanically. However, the synchronous generator has one main advantage over the induction generator, primarily, that it does not require a reactive magnetizing current.

In regards to embedded generation, synchronous generators are generally used in Combined Heat and Power (CHP) plants; some wind turbine application, Waste to Energy Plants as well as small scale hydro applications. Furthermore, just over 82%

[4] of the installed generation capacity in Ireland (Northern Ireland & Republic of Ireland) is comprised of synchronous generators.

2.3.2 Induction Generators

The induction generator is composed of a conventional armature winding and a squirrel-cage rotor. The induction generator is based on a very rugged and simple design which makes it less expensive compared to the synchronous machine. Over the last twenty years, the induction generator has played a large part in the wind industry thanks to its simple, rugged and inexpensive design (compared to the synchronous generator). However, the main draw back of the induction generator is the fact that the induction machine has no field windings which means that the current required to magnetise the machine must be supplied by the power system to which it is connected. Thus, the power system must be capable of supplying the lagging vars required to establish the air-gap flux in the induction generator [6]. These vars may be supplied by overexcited synchronous machines installed on the power system, or they can be supplied by shunt capacitors. When shunt capacitors are used at the terminals of the induction generator, the problem of self excitation must be considered.

As a generator, the induction machine is required to be driven by a prime mover (wind/water); and as the speed of the rotor is increased to equal synchronous speed, there is no relative motion between the rotor conductors and the flux. Hence, no voltage or current is induced in the rotor bars. Increasing the speed beyond synchronous speed causes a reversal in relative direction of rotation between the rotor bars and the flux, and thus the rotor voltage and current are reversed accordingly. The slip under this condition is considered to be negative. Essentially, shaft torque, supplied by the prime mover, is transferred across the air gap to the stator, from which it is delivered to the system as generated power. The net power output of the induction generator corresponds to the shaft input less the losses within the machine and is a function of the slip [6].

In Ireland (Northern Ireland & Republic of Ireland), less than 18% [4] of the installed generation capacity is comprised of induction generators. The vast majority of the induction generators installed on the Irish power system are located in wind farms spread out across the country. However, this percentage will increase due to the large number of wind farms predicted to come online over the next 10-15 years.

2.4 Wind Generation Technology

The following section looks briefly at the technology involved in wind generation namely the Fixed Speed Induction Generator, the Doubly Fed Induction Generator and the Inverter Interfaced Embedded Generator.

2.4.1 Doubly Fed Induction Generators

The Doubly-fed induction generator (DFIG) is one of the most popular types of generator used in wind turbines. This is primarily due to the fact that DFIGs allow variable speed operation to maximise the electrical power output. It is this fact that makes them very attractive for large wind-turbine applications. Figure 2.3 shows the basic layout of a DFIG wind turbine. It can be observed from Figure 2.3 that the rotor circuit is connected through slip rings to a back to back converter. The back to back converter arrangement is in turn controlled by Pulse Width Modulation (PWM) strategies. Both the voltage magnitude and power direction between the rotor and the supply can be varied by controlling the switch impulses that drive the Insulated Gate Bipolar Transistors (IGBTs) [25].

The back to back converters consist of two voltage source converters (ac-dc-ac) with a dc link capacitor connecting them. The generator side converter takes the variable frequency voltage and converts it into dc voltage. The grid side converter obtains the ac voltage from the dc link as an input and outputs an AC voltage at the specified grid voltage [25]. The role of the gearbox is to match the speed between the blades and the rotor. The stator is connected directly to the grid while the rotor needs a step down transformer in order to connect to the grid.

In addition, DFIGs can tolerate temporary voltage dips without disconnection, thus providing compliance with Grid and Transmission/Distribution Code requirements in terms of fault-ride-through capabilities. Furthermore, the DFIG has been observed to have little impact on the transient stability performance of the power system. Also, DFIG can provide sufficient reactive power support and voltage control to meet grid code requirements. However, one issue that has surfaced with the DFIG is the fault ride through capability during a local, solid three phase fault. Depending on the length of transmission line and the impedance of the transformer between the generator and the fault, the voltage at the low-voltage generator bus can sometimes dip slightly below the ride-through capability [23]. One method of counter acting this condition is

to supply a transformer with a slightly higher impedance to ensure the wind farm will not trip out during the fault [23].

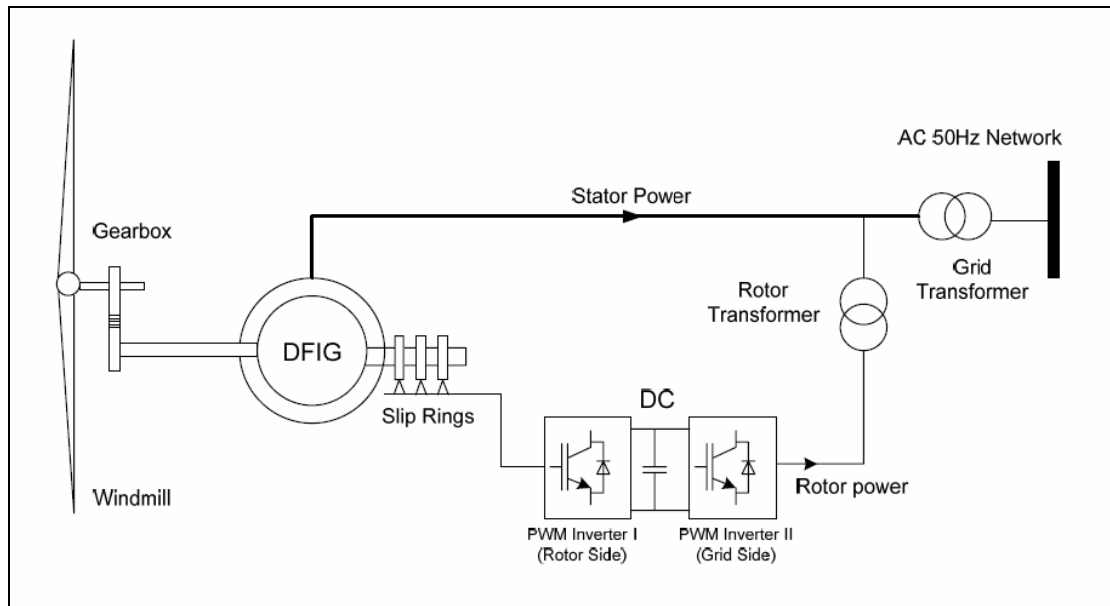

Figure 2.3: DFIG Wind Turbine System [25]

2.4.2 Fixed Speed Induction Generators

Fixed Speed Induction generators (FSIGs) are similar in design to induction motors in which torque is applied to the shaft by the prime mover. For fixed speed wind turbine, the generator utilised is a squirrel-cage induction generator which is directly connected to the grid as shown in Figure 2.4. The rotor of a FSIG rotates at a fixed speed which is determined by the grid frequency, the gear ratio and the pole pairs of the generator. Furthermore, a fixed-speed wind turbine is connected to the grid through a soft-starter.

In the case of the FSIG, the network supplies the necessary stator current to generate a rotating magnetic field. A rotor torque is then induced which acts against the direction of rotation. In order to maintain the speed above the synchronous speed (i.e. negative slip), the prime mover needs to overcome this torque. It should also be noted that at any given operating point, the prime mover must operate at constant speed. Finally, a simple form of control is required to maintain this speed (102-106% of synchronous speed). This is generally achieved through the utilisation of stall or pitch control in wind-farms.

FSIG wind turbines have the advantage of being robust, simple and generally cost-efficient compared to the other wind turbine types on the market. However, the reactive power consumption cannot be controlled. Another drawback associated with

the fixed speed wind turbine is that wind speed fluctuation is transmitted into the mechanical torque which in turn is transferred to the electrical power on the grid. The fluctuation in the power delivered to the grid can lead to large voltage fluctuation in the case where the wind farm is connected to a weak grid [38].

The risk of loss of synchronism due to over-speed* is other disadvantages of this type of wind turbine. While preventive/corrective measures could be taken, the measures available are confined to limiting acceleration during voltage dips through improvement in pitch control and providing reactive power support during and after the clearing of faults, via Flexible AC Transmission System (FACTS) devices. However, the installation of FACTS devices such as Static Var Compensators (SVCs) and STATCOMS can prove costly.

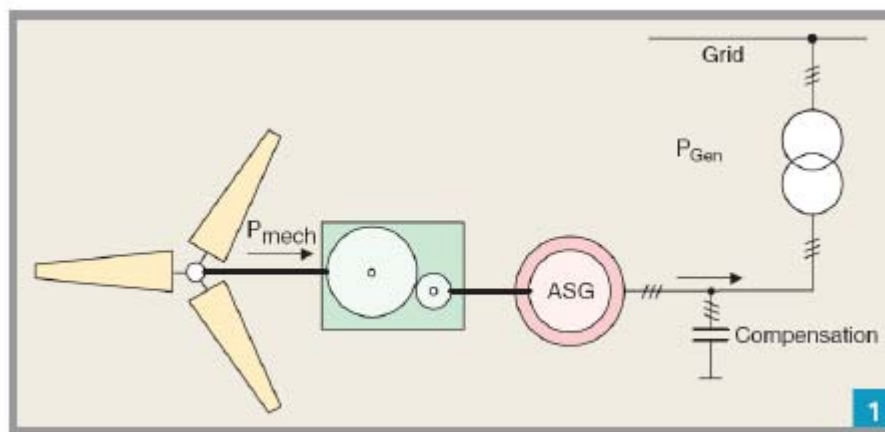

Figure 2.4: Direction Connection of Fixed-Speed Induction Generator to the Grid [33]

As previously stated, the main drawback of FSIG's is that, due to the lack of external excitation, these machines draw large amounts of reactive power from the grid. This reactive power is required to sustain the rotating magnetic field in the air gap between the cage rotor and the stator windings. As a result, induction generators can not operate independently from the grid. In order to overcome this fact, capacitor banks can be installed locally so provide reactive power compensation. Furthermore, wind farms connected via long cables can utilise the capacitance of the cable to provide some or all of its reactive power needs. In the case of the power factor correction capacitors and the long cable connections, the induction generator can go into "self-excitation" mode and conceivably operate disconnected from the grid. Self-excitation, as referred to for induction generators and motors, is the condition by which an

* Generally caused by voltage dips and increased reactive power consumption, especially during/after fault clearance.

electrical resonance occurs between the internal inductance of the machine and an external capacitance. This operating condition is highly undesirable as, depending on the saturation characteristics of the generator, large distorted voltages can be developed as the unit accelerates. This phenomenon has been reported to cause damage to equipment connected to an isolated part of a network fed by induction generators with power factor correction capacitors [14].

2.4.3 Inverter Interfaced Induction Generators

In the case of variable-speed wind turbines which utilise full converter technology, the generator can either be a squirrel-cage induction or a synchronous generator. The generator (synchronous or induction) is connected to the grid via a power electronic converter as shown in Figure 2.5. As observed in Figure 2.5, the total power output from generator flows through the converter. This in turn requires the converter to be rated to take the full power output of the generator. The advantage of the fully convertor connected wind turbine is that the voltage level and the reactive power can be regulated by the power electronic converters. However, the main advantages associated with this type of wind turbine are its dynamic behaviour during disturbances, with minimum transients at fault occurrence and clearing. The Inverter Interfaced Embedded Generator (IIEG) also has the capability to enhance active and reactive power control and in turn the compatibility of the wind turbine with grid code requirements can be satisfied [28].

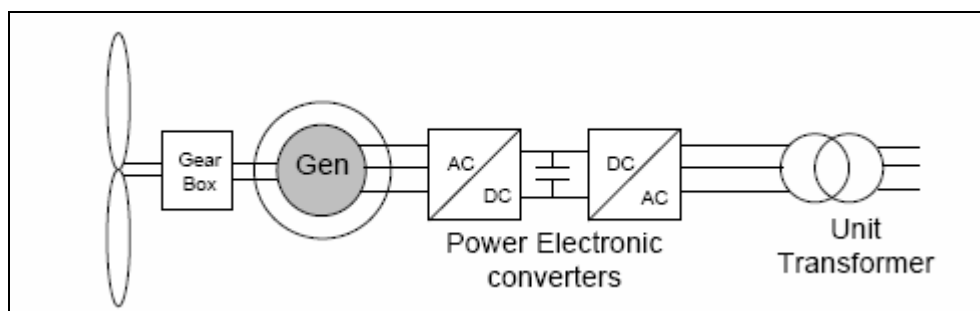

Figure 2.5: Full Converter Wind Turbine [26]

A feature of power electronic devices is that they cannot carry large currents for a sustained amount of time and, as a result, protection systems must be implemented in the controllers. In the event of a system fault, the generator will increase its current output to several times the rated current value of the generator according to its internal reactance. This sudden increase in current will be detected by the converters' protective circuits causing the controllers to stop the firing of the semiconductor

valves. This has the effect of limiting the fault current contribution of the turbine to a value close to the full rated current of the machine. The amplitude and duration of the fault current contribution is highly dependant on the controllers' strategy and the protection deployed on the controllers. While the limiting of the fault current contribution of the inverter interface wind turbine has its advantages, it also has its disadvantages especially for overcurrent protection which relies on a substantial difference between full load output of a turbine and fault conditions in order to make a correct trip/no trip decision. This area will be explored in more detail in chapter 3.

2.5 Integration of Embedded Generation into the Irish Power System

By the end of 2011, a total of 2021MW [4] of renewable capacity will be installed on the Irish (ROI) power system. Of the 2021MW of renewable capacity to be installed in 2011, almost 50% will be connected directly into the distribution system. Furthermore, it is predicted by 2020 that almost 4800MW (Figure 2.6) capacity will be installed in the Irish power system. In response, the TSO has set out its strategy in the form of Grid25 [22]. According to the strategy, over €4 billion will be spent in network reinforcement and renewal over the next 10 years. The expenditure will include the construction of 1,150km of new transmission circuits and the upgrading of 2,300km of the existing transmission circuits. This represents a massive investment in the Irish power system. These necessary network reinforcements are required to enhance system stability due to the large amount of renewable generation which will be connected over the next 10 years.

Another issue for the TSO is wind curtailment. In order to maintain system security, wind generation may have to be curtailed. The reasons for this include maintaining a minimum level of synchronous inertia on the system or to try and avoid overloading a transmission line [18]. While curtailment has not been a major issue to date, with the massive increase in wind generation capacity expected over the next 10 years, wind curtailment will fast become a major issue for concern from both a security and reliability point of view.

It is not just the transmission system which will experience major challenges in the coming years. Over the last 20 years, the Irish distribution system has shifted from a passive system to an active power system with bi-directional power flow. This has brought a number of challenges which include voltage control issues, stability issues,

potential islanding issues as well as protection issues. These challenges have also helped push the Smart Grid concept and the research/implementation of intelligent power systems. Over the last 10 years, a large number of technical papers have been written which explore the smart grid/intelligent power system concept. These technical papers cover all aspects to the smart grid concept and more importantly highlight the fact that the expectations held for the Smart Grid are increasing the pressure on all aspects of network operation for improved performance [7]. With the installation of significant amount of embedded generation into the distribution system over the next 10 years, the DSO will come under increasing pressure in terms of system stability, voltage control as well as protection.

Partially/Non-Dispatchable Plant in Ireland											
Year end:	2010	2011	2012	2013	2014	2015	2016	2017	2018	2019	2020
Onshore Wind (MW)	1538	1764	1990	2215	2441	2667	2893	3118	3344	3570	3796
Offshore Wind (MW)	0	36	36	252	252	252	252	416	529	533	555
Small Scale Hydro (MW)	22	22	22	22	22	22	22	22	22	22	22
Solid Biofuels (MW)	13	21	29	38	46	55	57	59	61	63	65
Landfill Gas (MW)	35	35	45	46	47	84	85	86	87	88	89
CHP (MW)	129	134	139	144	149	154	159	164	169	174	179
Industrial/DSU (MW)	9	9	9	9	9	9	9	9	9	9	9
Tidal/Wave (MW)	0	0	0	0	0	0	0	13	25	38	75
Total	1,746	2,021	2,270	2,726	2,966	3,243	3,477	3,887	4,246	4,497	4,790

Figure 2.6: Renewable Capacity in Ireland 2010 – 2020 [4]

Chapter 3

Interface Protection

3 Interface Protection

3.1 Introduction to Interface Protection

When an embedded generator seeks to connect to the Irish distribution system, it is required to install a suite of protection at the point of common coupling (PCC). The PCC marks the boundary between ESB Networks distribution system and the generator. The main protection requirements specified are under/over voltage, under/over frequency, overcurrent, loss of mains and earth fault. This protection is generally referred to as the interface protection and will be referred to as interface protection for the remainder of this thesis. It should be noted that different interface protection requirements apply depending on the generator type, connection method and voltage level. For example, a generator connecting to the system for the purposes of peak lopping would not require the same interface protection requirements as a generator which continuously feeds onto the distribution system.

There are a number of reasons for installing interface protection. The first reason is to ensure that any private generator connected is isolated from ESB Networks distribution system when abnormal or undesirable conditions occur on the distribution system. The second reason is to protect ESB staff, plant and customers from adverse effects which could be caused by the generator connecting to the distribution system.

It should also be noted that the DSO has a legal obligation to clear faults on the distribution system. These obligations are outlined in the following documents/rules/Statutory Instrument (SI):

- SI 44 of the Electricity Regulations / Part 7 SHAWAW '05
- DSO License condition 31.1
- Irish Distribution Code

Over the last twenty years, there have been two key documents produced by ESB Networks in regards to interface protection requirements which were as follows:

- Distribution Standard 931030: Parallel Operation of Private Generators, August 1995 (G10 Requirements) [15]
- Conditions Governing Connection to the Distribution System, March 2006 [9]

The following chapter will look at the Irish requirements for Interface protection which are outlined in “Conditions Governing Connection to the Distribution System, March 2006” and compare them to the requirements of Denmark, Finland, France,

Germany, Norway, Portugal, Spain and United Kingdom. The interface protection requirements for Denmark, Finland, France, Germany, Norway, Portugal and Spain are taken from a document compiled by CIGRE working group B5.34 entitled “The Impact of Renewable Energy Sources and Distributed Generation on Substation Protection and Automation”, August 2010 [37]. The interface protection requirements for the United Kingdom are taken from Engineering Recommendation G59 [16] and Engineering Recommendation G75 [17].

3.2 Interface Protection Requirements

The following Interface protection requirements will be looked at in detail for Ireland, Denmark, Finland, France, Germany, Norway, Portugal, Spain and the United Kingdom.

- Frequency Protection
- Voltage Protection
- Overcurrent Protection
- Earth Fault Protection
- Loss of Mains Protection

The above protection requirements will be compared and contrasted with a view to optimise the interface protection requirements for the Irish system.

3.2.1 Frequency Protection Requirements

The main forms of frequency protection are under frequency and over frequency protection. Under frequency protection is used to detect an overloading of a generator due to either a partial or complete loss of the grid supply to the local network. Under frequency relays are set to disconnect the generator if the frequency drops below a predefined threshold for a time greater than a user defined delay. Under frequency settings should be set to coordinate with under frequency load shedding schemes. This is important as load shedding schemes are designed to dump predefined blocks of load in an attempt to restore system frequency. If under frequency protection is not coordinated with load shedding schemes adequately, blocks of generation could be disconnected from the system which reduces the probability of a power system recovering from the initial overload. Over frequency protection is used to prevent damage to a generator caused by over-speeding resulting from a loss of load. Over

frequency relays are set to disconnect the generator if the frequency rises above a predefined threshold for a time greater than a user defined delay.

3.2.1.1 Irish Requirements

The under/over frequency protection requirements outlined by ESB Networks for embedded generation connecting to the Irish distribution system are outlined in Tables 3.1 and 3.2. It can be observed that for wind generation the frequency requirements are slightly looser compared with the requirements for synchronous generators shown in Table 3.1. One obvious observation is that the frequency requirements are significantly tighter than the system frequency requirements outlined in the Transmission and Distribution Code (see Figure 3.1). According to the distribution code, the normal operating range for the frequency is 49.8Hz to 50.2Hz with the frequency range extending to 48.0Hz to 52.0Hz during a system disturbance. Furthermore, the distribution code also outlines that wind farms should meet the following requirements (Figure 3.2):

- Remain connected to the Distribution System at Frequencies within the range 47.5 Hz to 52 Hz for a duration of 60 minutes.
- Remain connected to the Distribution System at Frequencies within the range 47.0 Hz to 47.5 Hz for a duration of 20 seconds required each time the Frequency is below 47.5 Hz.

However, the distribution code concedes that the above requirements are dependent on what frequency settings are implemented on the interface protection. With the settings outlined in Tables 3.1 and 3.2 below, the embedded generator would not meet the frequency requirements outlined in the distribution code. Immediately it is clear that the frequency settings could be tailored to be more in line with the transmission/distribution code frequency requirements for generators.

Interface Protection	Monitoring Details	Operating Settings (%)	Operating Settings (Hz)	Trip Time
Under Frequency	ESB Networks Supply 1ph	-4%	48.0Hz	< 0.5 seconds
Over Frequency	ESB Networks Supply 1ph	+1%	50.5Hz	< 0.5 seconds

Table 3.1: Irish Frequency Protection Settings for Embedded Generator Installations [9]

Interface Protection	Monitoring Details	Operating Settings (%)	Operating Settings (Hz)	Trip Time
Under Frequency	ESB Networks Supply 3ph	-6%	47.0Hz	0.5 seconds
Over Frequency	ESB Networks Supply 3ph	+1.6%	50.8Hz	0.5 seconds

Table 3.2: Irish Frequency Protection Settings for Embedded Generator Installations (Wind) [9]

DPC4.1	Frequency
DPC4.1.1	The frequency of supply is outside the control of the DSO however the expected standard frequency range is as follows: The Transmission System Frequency is nominally 50 Hz: (a) Normal operating range: 49.8 to 50.2 Hz. (b) During system disturbances: 48.0 to 52.0 Hz. (c) During exceptional System disturbances 47.0Hz to 52.0Hz

Figure 3.1: Frequency Limits – Distribution Code [11]

DCC11.3	FREQUENCY REQUIREMENTS
DCC11.3.1	FREQUENCY RANGES
	Wind Farm Power Stations shall have the capability to:
a)	operate continuously at normal rated output at Frequencies in the range 49.5 Hz to 50.5 Hz
b)	remain connected to the Distribution System at Frequencies within the range 47.5 Hz to 52 Hz for a duration of 60 minutes. Note that setting of the G10 Generator Interface Protection will determine actual operation in this range (see Table 6).
c)	remain connected to the Distribution System at Frequencies within the range 47.0 Hz to 47.5 Hz for a duration of 20 seconds required each time the Frequency is below 47.5 Hz.
d)	remain connected to the Distribution System during rate of change of Frequency of values up to and including 0.5 Hz per second.

Figure 3.2: Frequency Requirements – Distribution Code [11]

3.2.1.2 International Requirements

Denmark

Denmark has an installed capacity of 3734MW [40] of wind power with wind power accounting for over 21% of Danish electricity usage. The Eltra and Elkraft System are responsible for preparing technical regulations for connecting to the electricity supply grid as well as regulations relating to market player obligations. It can be observed from Table 3.3 that Danish frequency protection requirements are not as tight as Irish frequency protection requirements. In the case of over frequency protection, the

Danish allow a +6% increase in system frequency before tripping the generator. Furthermore, the Danish settings are more inline with the frequency requirements outlined in the Irish Transmission/Distribution code.

Interface Protection	Monitoring Details	Operating Settings (%)	Operating Settings (Hz)	Trip Time
Under Frequency		-6%	47Hz	0.3 seconds
		47Hz < f < 47.5hz		≥ 10 seconds
Over Frequency		+6%	53Hz	0.3 seconds

Table 3.3: Danish Frequency Protection Settings for Embedded Generator Installations [34], [24], [35]

Finland

Finland has an installed wind capacity of approximately 197MW. This capacity is miniscule compared with other countries. However Finland does have a significant amount of hydro installed. The Finnish frequency protection requirement can be found in SENER: Pienvoimaloiden liittäminen jakeluverkkoon (Connection of small power plants to distribution network), Helsinki 2001. While the under frequency protection setting is broadly inline with Danish and Irish requirements, the Finnish over frequency setting is only marginally broader than Irish requirements.

Interface Protection	Monitoring Details	Operating Settings (%)	Operating Settings (Hz)	Trip Time
Under Frequency		-6%	47Hz	0.2 seconds
Over Frequency		+2%	51Hz	0.2 seconds

Table 3.4: Finnish Frequency Protection Settings for Embedded Generator Installations

France

France has an installed wind capacity of 5660MW [20]. Overall, wind power now produces 1.8% of the country's electricity demand. However, at one point in November 2010, this share reached 7%. The French frequency protection requirements are outlined by the French Distribution System Operator (eRDF). On observation of the French frequency protection requirements it can be observed that the French have tighter frequency requirements compared to Ireland. This is understandable considering France is part of a heavily interconnected and heavily meshed power system. The French protection requirements would not be suited to the Irish system.

Interface Protection	Monitoring Details	Operating Settings (%)	Operating Settings (Hz)	Trip Time
Under Frequency	1 phase – phase Voltage	-1%	49.5Hz	Instantaneous
Over Frequency	1 phase – phase Voltage	+1%	50.5Hz	Instantaneous

Table 3.5: French Frequency Protection Settings for Embedded Generator Installations

Germany

Germany has an installed wind capacity of 27,214MW [20]. This is the largest wind capacity installed in Europe with only 1 or 2 countries outside of Europe with similar installed capacity. Wind energy generated 37.3 TWh of electricity in 2010, which accounted for 6.2% of the country’s power consumption. In total, 17% of electricity was generated from renewable sources in Germany in 2010, with wind being the single largest contributor [20]. A summary of German frequency protection requirement can be found in [37]. On observation of the German frequency protection requirements it can be observed that the Germans have similar frequency requirements to both the Danish and the Irish. However, the German over frequency protection requirements are broader compared to Ireland.

Interface Protection	Monitoring Details	Operating Settings (%)	Operating Settings (Hz)	Trip Time
Under Frequency		-5%	47.5Hz	0.1 seconds
Over Frequency		+3%	51.5Hz	0.1 seconds

Table 3.6: German Frequency Protection Settings for Embedded Generator Installations

Norway

Norway has an installed wind capacity of 423MW. While this would be considered small in comparison to other European countries, Norway has one of the largest hydro resources in Europe with approximately 30,000MW of Hydro capacity installed [45]. A summary of Norwegian frequency protection requirement can be found in [37]. It can be observed that the Norwegian frequency requirements are similar to Irish requirements. However, as seen with other countries, the Norwegian Over frequency setting is broader compared to Irish requirements.

Interface Protection	Monitoring Details	Operating Settings (%)	Operating Settings (Hz)	Trip Time
Under Frequency		-4%	48Hz	0.2 seconds
Over Frequency		+2%	51Hz	0.2 seconds

Table 3.7: Norwegian Frequency Protection Settings for Embedded Generator Installations

Portugal

Portugal has an installed wind capacity of 3702MW [20]. Portugal is one of the leading countries in Europe in terms of wind power penetration, with 17.1% of its electricity demand covered by nearly 4,000 MW of installed wind power capacity in 2010. A summary of Portuguese frequency protection requirement can be found in [37]. It can be observed that the Portuguese frequency requirements are broadly inline with those of Germany.

Interface Protection	Monitoring Details	Operating Settings (%)	Operating Settings (Hz)	Trip Time
Under Frequency		-5%	47.5Hz	0.0 -0.15 seconds
Over Frequency		+3%	51.5Hz	0.0 -0.15 seconds

Table 3.8: Portuguese Frequency Protection Settings for Embedded Generator Installations

Spain

According to the Spanish Wind Energy Association (AEE), the total wind capacity installed is approximately 20,676 MW [20]. Furthermore, Spain has the second highest total installed wind capacity after Germany. The leading region in Spain in terms of installed wind capacity is Castilla y León with almost 4,000 MW. In 2010, wind energy accounting for 16.6% of the national net power consumption. All renewable energy sources combined produced around 38% of Spain's electricity needs, with wind being the largest single contributor within the renewable energy mix [20]. A summary of Spanish frequency protection requirement can be found in [37]. It can be observed from Table 3.9 that the Spanish frequency requirements are similar to those of other European countries.

Interface Protection	Monitoring Details	Operating Settings (%)	Operating Settings (Hz)	Trip Time
Under Frequency		-4%	48.0Hz	3 seconds
Over Frequency		+2%	51.0Hz	0.2 seconds

Table 3.9: Spanish Frequency Protection Settings for Embedded Generator Installations

United Kingdom

The United Kingdom has an installed wind capacity of 5204MW [20] and is ranked the 8th largest producer of wind power. The two main documents in the UK in regards to interface protection requirements for embedded generation are Engineering recommendation G59 [16] and Engineering Recommendation G75 [17]. Table 3.10 below outlines the frequency protection settings. It can be observed that the UK has adopted multi stage frequency protection. Multi stage frequency protection has advantages which are discussed in section 3.2.1.3.

Interface Protection	Monitoring Details	Operating Settings (%)	Operating Settings (Hz)	Trip Time
Under Frequency	Stage 1	-5%	47.5Hz	20 seconds
	Stage 2	-6%	47.0Hz	0.5 seconds
Over Frequency	Stage 1	+3%	51.5Hz	90 seconds
	Stage 2	+4%	52.0Hz	0.5 Seconds

Table 3.10: UK Frequency Protection Settings for Embedded Generator Installations

3.2.1.3 Discussion

On observation of Irish under/over frequency protection requirements, it is clear that the Irish frequency settings can be improved. The first improvement would be the introduction of multi stage frequency protection. This would not be seen as a costly introduction as most frequency protection devices allow for multi stage frequency protection as standard. Furthermore, multi stage frequency protection can allow for enhanced control over the power system provided intelligent settings are chosen.

Table 3.11 proposes alternative under/over frequency settings to the settings proposed in [9]. These settings would allow for the frequency requirements in the Transmission/Distribution code to be implemented and at the same time providing rapid disconnection of the embedded generator for extreme system conditions.

Choosing 47Hz as the lower threshold has merit in that in the event that the system frequency reached 47Hz, it can be assumed that load shedding schemes on the system

have operated and were unsuccessful. At this stage the system would be heading for a blackout condition and the generator should be disconnected (if not already disconnected) for reconnection when the system is restored. Choosing 52.5Hz as the upper threshold also has merit as this setting allows for ramping down of the power output of larger machines before disconnecting the embedded generator.

It should be noted that the settings below are currently been considered by the DSO as part of the DSO’s review of Interface protection requirements for embedded generators.

Interface Protection	Monitoring Details	Operating Settings (%)	Operating Settings (Hz)	Trip Time
Under Frequency	2 phases (minimum)	$\leq -6\%$	47.0Hz	0.5 seconds
Over Frequency	2 phases (minimum)	$\leq -5\%$	47.5Hz	20 seconds
		$\geq +4\%$	52.0Hz	20 seconds
		$\geq +5\%$	52.5Hz	0.5 seconds

Table 3.11: Proposed Frequency Protection Settings for Embedded Generator Installations

3.2.2 Voltage Protection Requirements

The main forms of voltage protection are under voltage and over voltage protection. Under voltage protection is required to detect voltage depressions caused by a close in fault and to trip the embedded generator after a predefined time delay. The under-voltage protection function is important for the detection of immediate network faults (either phase-phase or three-phase) for which overcurrent protection may not operate. This is primarily due to the possible low current contribution from the EG (technology specific). This issue is of particular significance to EG technologies deemed incapable of supporting short-circuit current contribution such as Fixed Speed Induction Generators, Doubly Fed Induction Generators and Inverter Interfaced Induction Generators. In the circumstances where the fault current contribution of the generator cannot be relied upon, the under-voltage protection function is the only reliable means of fault detection. The undervoltage protection is set to disconnect the generator if the voltage dips below a predefined threshold for a time greater than a user defined delay.

Overvoltage protection is required to protect equipment against damage caused by overvoltages on the system. The main causes of overvoltages on a network are

switching operations, load rejection, over-speed, lightning and earth faults. The overvoltage protection is set to disconnect the generator if the voltage rises above a predefined threshold for a time greater than a user defined delay.

3.2.2.1 Irish Requirements

The under/over voltage protection requirements outlined by ESB Networks for embedded generation connecting to the Irish distribution system are shown in Tables 3.12 and 3.13 below. It can be seen that for wind generation the voltage requirements are slightly looser compared with the requirements for synchronous generators shown in Table 3.12.

Interface Protection	Monitoring Details	Operating Settings (%)	Trip Time
Under Voltage	ESB Networks Supply 3ph	-10%	< 0.5 seconds (Typical)
Over Voltage	ESB Networks Supply 3ph	+10%	< 0.5 seconds (Typical)

Table 3.12: Irish Voltage Protection Settings for Embedded Generator Installations

Interface Protection	Monitoring Details	Operating Settings (%)	Trip Time
Under Voltage	ESB Networks Supply 3ph	-20%	1 second
Over Voltage	ESB Networks Supply 3ph	+10%	< 0.5 seconds (Typical)

Table 3.13: Irish Voltage Protection Settings for Embedded Generator Installations (Wind)

It should be noted that the voltage requirements above are in conflict with the fault ride through requirements outlined in the distribution code. Figures 3.3 and 3.4 outline the fault ride through requirements for generators connecting to the distribution system. Super-imposing the under voltage requirements on to the fault ride through requirements (Figures 3.5 & 3.6), it can be seen that for wind farms connecting directly to 110kV busbars, the under voltage protection requirements conflict with the fault ride through requirements. It is clear that some modifications to

the voltage settings can be done to bring the voltage protection requirements inline with the fault ride through requirements outlined in the distribution code.

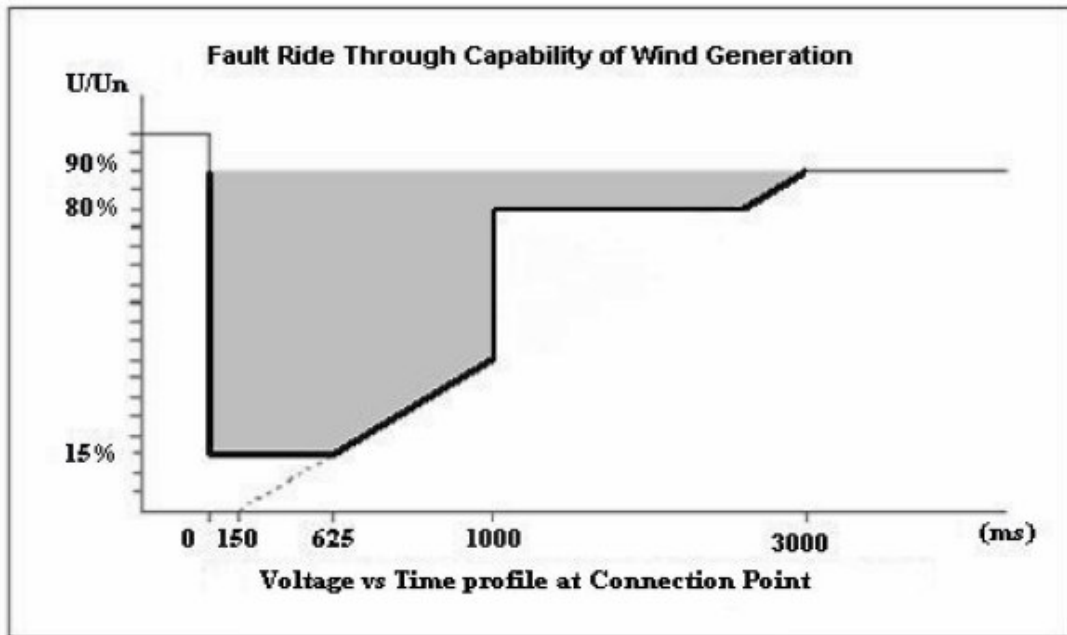

Figure 3.3: Fault Ride Through Capability for Types B, C, D and E Wind Farm Power Stations Connected to the Distribution System [11]

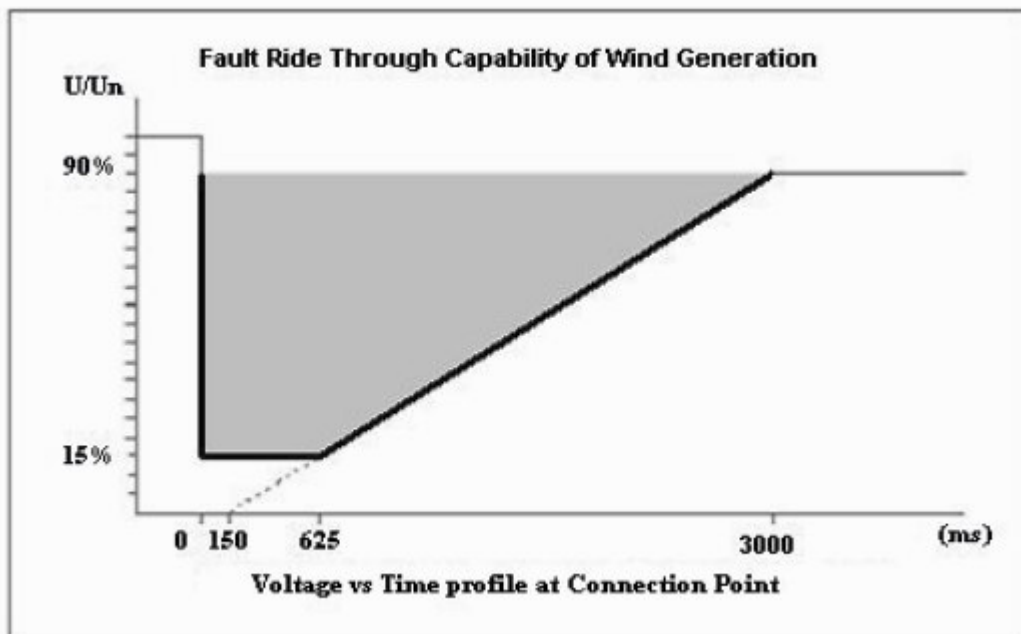

Figure 3.4: Fault Ride Through Capability for Types A Wind Farm Power Stations Connected to the Distribution System [11]

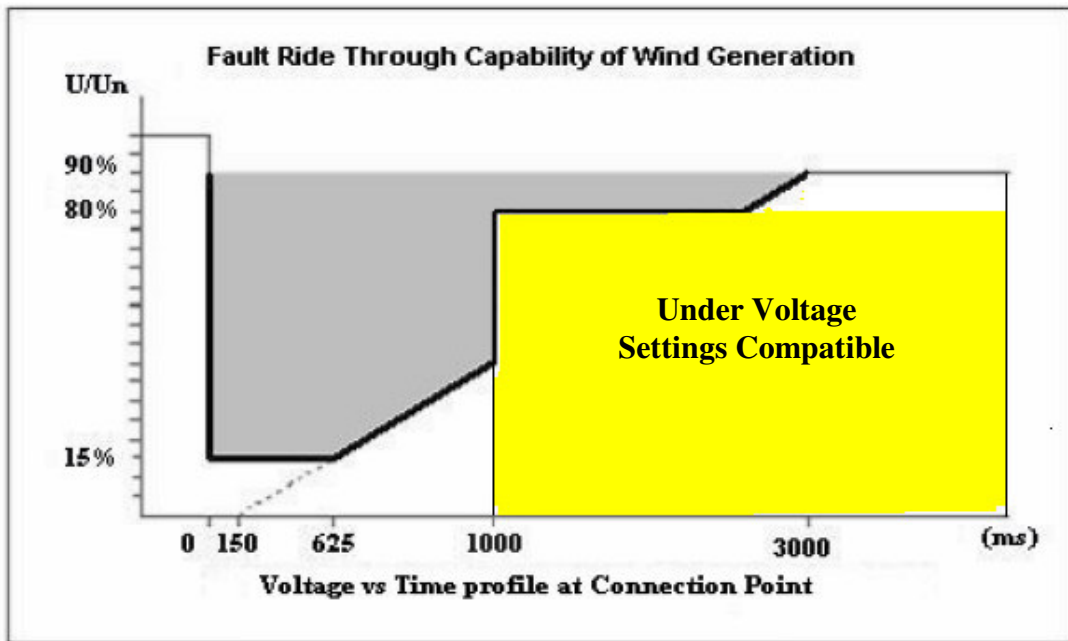

Figure 3.5: Fault Ride Through Capability for Types B, C, D and E Wind Farm Power Stations Connected to the Distribution System [11]

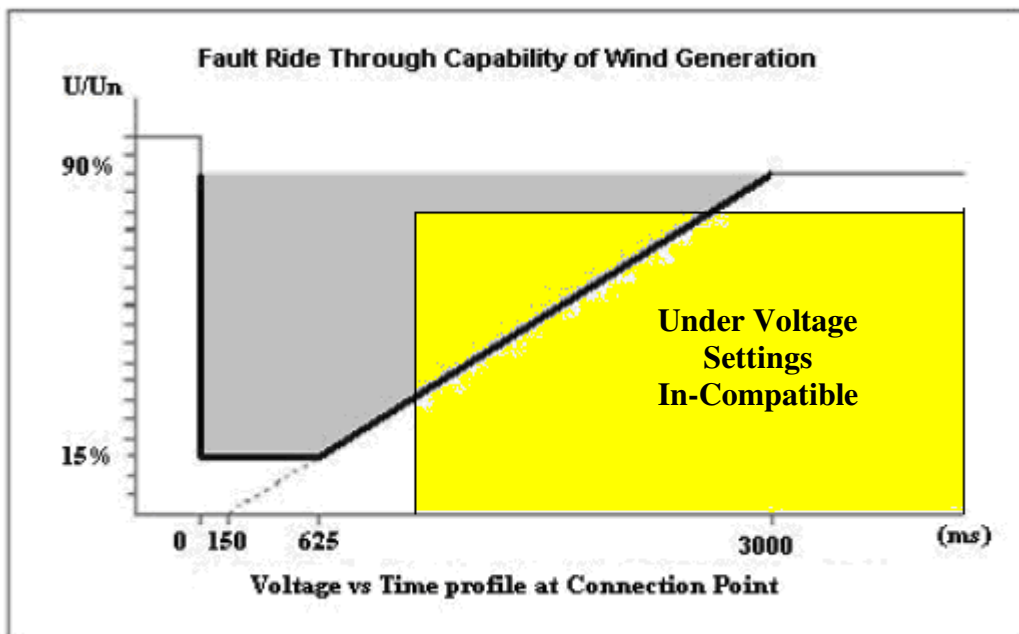

Figure 3.6: Fault Ride Through Capability for Types A Wind Farm Power Stations Connected to the Distribution System [11]

3.2.2.2 International Requirements

Denmark

The Danish voltage protection requirements are outlined in Table 3.14 below. It can be observed that the Danish require multi stage voltage protection. The advantage of this approach is two fold in that:

- Rapid clearance of the generator can be achieved for close in faults where fast fault clearance is required (stability)
- Slow clearance of the generator for remote faults

Interface Protection	Monitoring Details	Operating Settings (%)	Trip Time
Under Voltage		< 90%	2 -10 seconds
		< 70%	0.05 seconds
Over Voltage		>106%	30 - 60 seconds
		>110%	0.05 seconds

Table 3.14: Danish Voltage Protection Settings for Embedded Generator Installations

Finland

The Finnish voltage protection requirements are outlined in Table 3.15 below. Similar to the Danish, the Finnish also utilise multi stage voltage protection.

Interface Protection	Monitoring Details	Operating Settings (%)	Trip Time
Under Voltage		< 90%	2 – 10 seconds
		< 50%	50 – 100ms
Over Voltage		> 106%	30 – 60 seconds
		> 110%	50ms

Table 3.15: Finnish Voltage Protection Settings for Embedded Generator Installations

France

The French voltage protection requirements are outlined in Table 3.16 below. The French also utilise multi stage voltage protection.

Interface Protection	Monitoring Details	Operating Settings (%)	Trip Time
Under Voltage		85%	1 – 2 seconds
		25%	Instantaneous
Over Voltage		115%	0.1 seconds

Table 3.16: French Voltage Protection Settings for Embedded Generator Installations

Germany

The German voltage protection requirements are outlined in Table 3.17 below. As seen with Denmark, Finland and France, the Germans also utilise multi stage voltage protection.

Interface Protection	Monitoring Details	Operating Settings (%)	Trip Time
Under Voltage ²		80%	1.5 – 2.4 seconds
Under Voltage ³		80%	1 second
Over Voltage		25%	Instantaneous
		120%	0.1 seconds

Table 3.17: German Voltage Protection Settings for Embedded Generator Installations

Norway

The Norwegian voltage protection requirements are outlined in Table 3.18. As observed with Denmark, Finland, France and Germany, the Norwegians also utilise multi stage voltage protection.

Interface Protection	Monitoring Details	Operating Settings (%)	Trip Time
Under Voltage		< 85%	1.5 seconds
		< 50%	0.2 seconds
Over Voltage		> 105%	1.5 seconds
		> 115%	0.2 seconds

Table 3.18: Norwegian Voltage Protection Settings for Embedded Generator Installations

Portugal

The Portuguese voltage protection requirements are outlined in Table 3.19. It can be observed that Portuguese requirements are similar to Irish voltage protection requirements.

Interface Protection	Monitoring Details	Operating Settings (%)	Trip Time
Under Voltage		85%	1 second
Over Voltage		115%	1 second

Table 3.19: Portuguese Voltage Protection Settings for Embedded Generator Installations

² Connection to a MV substation through a dedicated line

³ Connection to MV line

Spain

The Spanish voltage protection requirements are outlined in Table 3.20. It can be observed that Spanish requirements are similar to Irish voltage protection requirements.

Interface Protection	Monitoring Details	Operating Settings (%)	Trip Time
Under Voltage		80%	0.6/1.2 seconds ⁴
Over Voltage		115%	0.2 seconds

Table 3.20: Spanish Voltage Protection Settings for Embedded Generator Installations

United Kingdom

The UK voltage protection requirements are outlined in Table 3.21. As observed with Denmark, Finland, France, Germany and Norway, the UK also utilise multi stage voltage protection.

Interface Protection	Monitoring Details	Operating Settings (%)	Trip Time
Under Voltage	Stage 1	-13%	2.5 seconds
	Stage 2	-20%	0.5 seconds
Over Voltage	Stage 1	+10%	1.0 seconds
	Stage 2	+15%	0.5 seconds

Table 3.21: UK Voltage Protection Settings for Embedded Generator Installations

3.2.2.3 Discussion

On observation of Irish under/over voltage protection requirements, it is clear that the Irish voltage settings can be improved. The first improvement is the use of multi stage voltage protection. The advantage of multi stage voltage protection is that the settings can be tailored to provide rapid clearance for close in faults and delayed tripping for remote faults. This would not be seen as a costly introduction as most voltage protection devices allow for multi stage voltage protection as standard. The second improvement would be to modify the existing voltage protection settings to aid fault ride through compliance for the generator.

The over voltage setting should be modified in order to be compatible with the operating voltage limits outlined in the distribution code (Figure 3.7). A setting of 1.13pu would be compatible with the operating voltage limits outlined in the

⁴ Default Setting/Meet Fault Ride Through Requirements

distribution code. Furthermore, a timer setting of 0.7 seconds is recommended in order to comply with the fault ride through requirements outlined in the distribution code. The proposed alteration to the overvoltage setting would also comply with the overvoltage requirements outlined in the incoming entsoe requirements.

Nominal voltage	Highest voltage	Lowest voltage
230V	253V	207
400V	440V	360
10kV	11.1kV	Variable according to operating conditions. Information on particular location on request by user concerned
20kV	22.1kV	
38kV	43kV	
110kV	120kV	

Figure 3.7: Operating Voltage Limits [11]

Table 3.22 proposes alternative under/over voltage settings to the settings proposed in [9]. The settings below would be considered compatible with the fault ride through requirements outlined in the distribution code. Furthermore, the settings strike a balance between the fault ride through requirements and rapid clearance of the generator for close-in faults. The settings proposed below are also in-line with the voltage protection requirements outlined by other utilities.

Interface Protection	Monitoring Details	Operating Settings (%)	Operating Settings (pu)	Trip Time
Under Voltage⁵	3 phases	< -13%	0.87	3.0 seconds
		< -20%	0.80	1.0 second
Under Voltage⁶	3 phases	< -13%	0.87	2.5 seconds
		< -50%	0.50	1.85 seconds
Over Voltage	3 phases	> +13%	1.13	0.7 seconds

Table 3.22: Proposed Voltage Protection Settings for Embedded Generator Installations

3.2.3 Overcurrent Protection Requirements

The main function of overcurrent protection is to disconnect the generator if a fault on the network has not been cleared within an acceptable time limit. The relays purpose is to protect the distribution system against excessive damage and prevents the generator from exceeding its thermal limits. When considering overcurrent settings, it is necessary to ensure that the settings are set high enough to allow the maximum

⁵ Wind Farm Types B,C,D and E

⁶ Wind Farm Type A

conceivable output of the wind farm. However, it is also important to ensure that the overcurrent protection is capable of picking up for remote faults. For synchronous machines, overcurrent protection is adequate as in the event of a fault, the synchronous machine will supply an acceptable level of fault current that should result in the operation of the overcurrent protection. For synchronous generators the difference between full load output and fault current contribution can be as much as 5 – 10 times rated output of the machine.

However, for embedded generation composing of induction or DFIG technology, acceptable level of fault current cannot be relied upon to operate overcurrent protection. Due to the rapid decay in fault current contribution from these devices in the event of a fault, an overcurrent relay at the embedded generator connection point could not be relied upon to pick up for an external fault.

3.2.3.1 Irish Requirements

Table 3.23 below outlines the Irish overcurrent protection requirements. It can be observed that the overcurrent setting is set at 120% of the Maximum Export Capacity (MEC) of the generator. The setting below would be considered adequate for a synchronous generator as the generator would be more than capable of supplying the required fault current to be capable of discerning between fault and load. However, for a wind farm composed of multiple induction generators or DFIGs, a setting of 120% would be unreliable as depending on the number of wind turbines operating at the time of a fault and the technology involved, the wind farm may be incapable of supplying the required fault current to trigger the overcurrent protection.

Interface Protection	Monitoring Details	Operating Settings (%)	Trip Time	Notes
Directional Overcurrent ⁷	ESB Networks Supply 3ph	≤ 50%	< 0.5 seconds	No- Export Generators
	ESB Networks Supply 3ph	≤ 120%	< 0.5 seconds	Generators with agreed export

Table 3.23: Irish Overcurrent Protection Settings for Embedded Generator Installations

⁷ May not be required if generator rating is < 1MVA @ MV PCC or < 200kVA @ LV PCC

3.2.3.2 International Requirements

Denmark

Table 3.24 outlines the overcurrent requirements for Denmark. The overcurrent protection is required to trip in 50ms once the current reaches a pre-defined threshold. However, the threshold for the overcurrent protection is determined by the utility. Negative sequence overcurrent protection is important to ensure the generator is protected against negative sequence currents which can lead to excessive heating and damage to the generator.

Interface Protection	Monitoring Details	Operating Settings (%)	Trip Time
Overcurrent		I>>	0.05 seconds
Negative Sequence Current		5-20%	3 - 10 seconds

Table 3.24: Danish Overcurrent Protection Settings for Embedded Generator Installations

Finland

Similar to Denmark, overcurrent protection is required by the Finnish. However, the technical details relating to the implementation of overcurrent protection must be agreed with the utility.

France

The provision of overcurrent protection is not strictly defined by the French. However, the Installation of this type of protection must be agreed with the DNO.

Germany

The provision of short circuit protection is required for LV systems. The technical details concerning the actual implementation of the short circuit protection are not stated. However, the guidelines state that if the DG unit leads to the short circuit current of the grid to be higher than the rated short circuit current, the short circuit of the distributed generator has to be limited.

Norway

The provision of Overcurrent protection is required. However, the technical details relating to the implementation of overcurrent protection must be agreed with the utility.

Portugal

Table 3.25 outlines the overcurrent protection requirements outlined by the Portuguese. It can be observed that the Portuguese require a setting between 100 – 200% of rated current with a trip time between 0 and 1 second. The specific settings must be agreed with the utility.

Interface Protection	Monitoring Details	Operating Settings (%)	Trip Time
Overcurrent		100 - 200% In	0 - 1 second

Table 3.25: Portuguese Overcurrent Protection Settings for Embedded Generator Installations

Spain

The provision of overcurrent protection is required by the Spanish. Installation of this type of protection must be agreed with the DNO.

United Kingdom

The provision of short circuit protection is considered by G59/1. In the event that overcurrent protection is deemed necessary by the Public Electricity supplier (PES), the implementation and setting of the protection must be agreed with the PES.

3.2.3.3 Discussion

The provision of overcurrent protection is required by the Danish, French, Finnish, Norwegian, Spanish, Portuguese, German and the UK. The precise setting for the overcurrent protection is provided by the utilities in the respective countries. The installation of overcurrent protection has both its advantages and disadvantages. For synchronous machines, the difference between full load output and fault conditions is considered wide enough to ensure correct operation of the protection device. Furthermore, overcurrent protection is widely available and is considerably cheaper than other forms of protection. However, for induction machines, DFIG's and full

converter connected generators; overcurrent protection cannot be considered to be reliable enough. For wind farms, depending on the number of generators on line at the time of the fault and the technology involved, the contribution from the wind farm may not be sufficient to operate the overcurrent protection. Furthermore, depending on the time of year (Summer Night Valley/Winter Peak) the short circuit level will vary on the power system. In the case of Ireland, it is recommended that the overcurrent protection requirement should be dropped for induction generator based technology and full converter interfaced technology and replaced by a more reliable form of protection. The replacement of overcurrent protection with duplicate under voltage protection would be considered a more reliable as well as a cost effective solution. For synchronous generators, the overcurrent protection requirement can be kept for aforementioned reasons.

3.2.4 Earth Fault Protection Requirements

Earth fault protection is required for the detection of earth faults on the power system. The most popular form of earth fault detection is Neutral Voltage Displacement (NVD) protection. This form of protection is generally installed on the neutral of a transformer and would be considered reliable. The installation of a zero sequence current relay can also be used to detect earth faults on the system. The type and operation of earth fault protection is dependent on the grounding connection to which the embedded generator is connected too.

3.2.4.1 Irish Requirements

The earth fault requirements outlined by ESB Networks can be observed in Table 3.26. It can be seen that ESB Networks require the earth fault protection to be set to detect a 30% NVD with a required operation time of ≤ 30 seconds.

Interface Protection	Monitoring Details	Operating Settings (%)	Trip Time
Earth Fault	ESB Networks MV or 38kV Supply	30% NVD ⁸	≤ 30 seconds

Table 3.26: Irish Earth Fault Protection Settings for Embedded Generator Installations

⁸ Neutral Voltage Displacement

3.2.4.2 International Requirements

Denmark

The Danish earth fault protection requirements are shown in Table 3.27. It can be observed that the Danish require NVD protection to detect 20% NVD with an operation time of 60 seconds.

Interface Protection	Monitoring Details	Operating Settings (%)	Trip Time
Earth Fault	Vn	20%	60 seconds

Table 3.27: Danish Earth Fault Protection Settings for Embedded Generator Installations

Finland

Earth Fault protection is required for MV networks. The technical details relating to the implementation of the earth fault protection are to be agreed with the utility.

France

The French earth fault requirements are shown in Table 3.28 (RTE) and Table 3.29 (eRDF). The RTE make provisions for the implementation of either overcurrent earth fault protection or zero sequence voltage protection. The RTE requirements are considerably broader than the Irish requirements. The eRDF outline zero sequence voltage requirements for earth fault detection. The eRDF requirements are considerably tighter than the Irish earth fault protection requirements.

Interface Protection	Protection Type	Operating Settings	Trip Time
Earth Fault	51N	100A	4 seconds
	59N	$V_0 = 0.5V_n$	4 seconds

Table 3.28: French Earth Fault Protection Settings for Embedded Generator Installations (RTE)

Interface Protection	Protection Type	Operating Settings (%)	Trip Time
Earth Fault	59N	10% Vn	1 - 2 seconds

Table 3.29: Earth Fault Protection Settings for Embedded Generator Installations (eRDF)

Germany

The requirement for the implementation of earth fault protection is not strictly defined in German Embedded Generator requirements.

Norway

The provision of earth fault protection is not specifically defined by the Norwegians. However, the technical details relating to the implementation of the earth fault protection must be agreed with the utility.

Portugal

The Portuguese earth fault protection requirements are outlined in Table 3.30. The Portuguese outline both voltage and current requirements for the detection of earth faults. The Portuguese require the NVD protection to operate for a 10% voltage displacement in 1 second. The Portuguese zero sequence current settings are set at 10% threshold to operate in 0.4 seconds. The Portuguese earth fault settings are considerably tighter compared with Irish requirements.

Interface Protection	Protection Type	Operating Settings	Trip Time
Earth Fault	50N	10% In	0.4 seconds
	59N	10% Vn	1.0 second

Table 3.30: Portuguese Earth Fault Protection Settings for Embedded Generator Installations

Spain

The Spanish earth fault protection settings are outlined in Table 3.31. The Spanish specify a zero sequence voltage setting of 35% with a trip time of either 0.6 seconds (default) or 1.2 seconds (Fault Ride Through Requirements). While the pickup setting is similar to the Irish requirement, the operating time is significantly quicker compared with Irish requirements.

Interface Protection	Protection Type	Operating Settings	Trip Time
Earth Fault	59N	35% Vn	0.6/1.2 seconds

Table 3.32: Spanish Earth Fault Protection Settings for Embedded Generator Installations

United Kingdom

The UK requirements for earth fault detection are outlined in Table 3.32. The UK have an identically pickup settings compared to Irish earth fault requirements. However, the trip time must be agreed with the distribution system operator. The similar earth fault settings are understandable considering the Irish and UK power systems have numerous similarities in terms of grounding arrangements etc.

Interface Protection	Protection Type	Operating Settings	Trip Time
Earth Fault	NVD	>30% V _n	Time Delayed to coordinate with network ground fault protection

Table 3.32: UK Earth Fault Protection Settings for Embedded Generator Installations

3.2.4.3 Discussion

The provision of earth fault protection is required by the Danish, French, Finnish, Norwegian, Spanish, Portuguese, German and the UK. On comparison of international requirements with Irish requirements, it can be observed that there are similarities especially between Ireland and the UK. This is understandable considering the similarities between the two countries in terms of voltage levels, frequency and grounding arrangements. The main conclusion which can be reached in regards to earth fault protection is that the requirement for the interface protection to trip the embedded generator for earth faults should be dependent on the how earth faults are treated on the network by the utility. For example, earth fault protection installed on the 38kV system in Ireland is set to indicate and not trip for earth faults. This is due to the fact that the 38kV system in Ireland is grounded via a Peterson Coil. Therefore earth fault protection installed at the interface for 38kV connected embedded generators should be set to indicate and not trip for earth faults.

3.2.5 Loss of Mains Protection Requirements

When a fault occurs on the distribution system, the protection installed on the power system detects the fault and sends a trip command to a circuit breaker. The fault is said to be isolated when the fault is cleared from all sources of supply. When the distribution system was considered to be a passive system with very little or no embedded generation installed, the clearance of faults was considered straight forward and under the control of the distribution system operator. However, the introduction

of embedded generation has considerably complicated the fault clearance process. One of the main issues with embedded generation is the risk of islanding. In the event of a fault, an embedded generator could become islanded. This can result in an embedded generator supplying the part of the distribution network which has been islanded from the main power system. It should be noted that the chances of an embedded generator continuing to operate after the loss of the grid connection are extremely low. However, with more and more embedded generation coming online over the next 5 – 10 years, the risk of islanding is becomes greater especially if the generators are capable of islanded operation.

The main reason why islanding is extremely rare is due to the fact that sustained islanding requires the exact matching of both active and reactive power in the disconnected section of the network as well as the generator having the capability of exercising some degree of voltage and frequency control. While the possibility of sustained islanding is a rare event, it is not impossible and can prove costly if it occurs (YEDL use intertripping due to an islanding incident in the past). However, temporary islanding lasting a few hundred milliseconds, or even seconds, is not implausible.

The main problems associated with islanding are quality of supply to the customer, health and safety concerns and resynchronisation of the generator to the network. If islanding occurs, the quality of supply to customers on the islanded system cannot be guaranteed as the utility no longer has control over the islanded section of network. This can result in degraded power quality for the customers connected to the islanded piece of network. Furthermore, the subsequent resynchronisation of the island to the grid after a disturbance can result in out-of-phase re-closing since synchronising facilities are not available at distribution networks installations. Out-of-phase re-closing can produce power transients in the local system which could affect the utility and/or the generator. The risks associated with out-of-phase re-closing are as follows:

- Stress/damage to the generators and motors connected to the island.
- Substantial degradation of the network's reliability
- Damage to the network switch/CB/fuse used to make the out of synchronous re-closure.
- A potential safety hazard to an operator.

The main forms of Loss of Mains protection are Rate of Change of Frequency (ROCOF) and Vector Shift (VS).

Rate of Change of Frequency Protection

ROCOF protection work on the basis that if islanding occurs, there will be an imbalance between the generation and load in the islanded network [41][1]. Once islanding has occurred, the ensuing power imbalance will cause the frequency to increase/reduce dynamically depending on a generation surplus/deficit. Immediately after the islanding event, the power imbalance will cause the frequency to change. The rate at which the frequency changes can be approximated by the following equation if governor action is ignored: [14], [30].

$$\frac{df}{dt} = - \left(\frac{P_L - P_G}{2HxS_{GN}} x f_r \right)$$

Where

P_G = Output of the distributed Generator

P_L = Load in the Island

S_{GN} = Distributed Generator Rating

H = Inertia Constant of Generating Plant

F_r = Rated Frequency

ROCOF protection measure the rate at which the frequency changes and once the rate of change of frequency exceeds a pre-set threshold, a trip signal is sent to the breaker and the breaker opens. However, other system events could theoretically cause ROCOF protection to operate. For example, network transient events could conceivably cause a change in the system frequency, which in turn can result in the incorrect operation of ROCOF protection. While ROCOF protection can be set very sensitive and can in theory provide reliable operation for islanding events, it is the potential spurious operation for transient events on the system that are of most concern [36].

Furthermore it has been observed in [41] that ROCOF protection from different manufacturers can operate differently to the same event on a power system, even when the devices are setup with the exact same settings. This is due to the fact that different manufactures use different methods to detect rate of change of frequency. It is these differences which can result in spurious operation of the ROCOF protection.

Vector Shift Protection

Voltage Vector Shift protection is based upon voltage angle measurements performed on phase voltages. Depending upon the manufacturer, vector shift protection can use either single phase or three phase voltage quantities to make a decision. While using single phase voltage quantities to make a decision is perfectly adequate, the use of three phases makes the vector shift relay immune to harmonic distortion as well as other sources of interference.

The Vector Shift relay works by measuring the length of each cycle of the voltage waveform. If the grid becomes disconnected from the local distribution system (fault condition/mal operation of a protection device etc.), the sudden change in the generation/load balance will invariably result in a sudden change in the voltage cycle length. The change in waveform length is translated into a value in degrees. When this value exceeds a predefined threshold, the vector shift protection operates. Unfortunately the Vector Shift method suffers from the same problems associated with ROCOF protection. The vector shift relay is susceptible to incorrect operation for network transient events. Nuisance trips have been observed by many utilities in the presence of normal network events, such as line switching operations, capacitor bank switching etc. Furthermore, there have been events where the vector shift relay has failed to operate for valid trip conditions where the power imbalance between the generator and the grid is low.

3.2.5.1 Irish Requirements

The Irish requirements for loss of mains detection are outlined in Tables 3.33 and 3.34. It can be observed that provisions are made for both vector shift and ROCOF protection. It can be observed from Table 3.35 that for wind generators, the ROCOF protection is desensitised slightly.

Interface Protection	Monitoring Details	Operating Settings (%)	Trip Time	Notes
Loss of Mains	3 phase	Typical 0.4Hz/sec	< 0.5 seconds	Rate of Change of Frequency (ROCOF)
	1 phase + asymmetry relay	Typical 6 Degrees	< 0.5 seconds	Vector Shift

Table 3.33: Irish Loss of Mains Protection Settings for Embedded Generator Installations

Interface Protection	Monitoring Details	Operating Settings (%)	Trip Time	Notes
Loss of Mains	3 phase	0.55Hz/sec	< 0.5 seconds	Rate of Change of Frequency (ROCOF)

Table 3.34: Irish Loss of Mains Protection Settings for Embedded Generator Installations (Wind)

3.2.5.2 International Requirements

Denmark

The loss of main protection requirements are outlined in Table 3.35. It can be observed that the Danish loss of mains requirements are substantially broader compared with Irish requirements. The ROCOF relay has given rise to a significant amount of forced outages of local CHP units connected to the Danish distribution system. The reason is partly that some types of ROCOF relays are sensitive to the phase shift which is a resultant of short circuits and couplings in the network and partly because Eltra's originally recommended settings were considered to be too sensitive for the ROCOF relay ($df/dt > 1.5 \text{ Hz/s}$ and $df/dt < -0.7 \text{ Hz/s}$). The increase of the ROCOF settings to $\pm 2.5 \text{ Hz/s}$ has resulted in increased stability in the Danish distribution system. However, desensitising the protection means the ROCOF protection may not pick up for cases where the difference between load and generation is small.

Interface Protection	Monitoring Details	Operating Settings (%)	Trip Time	Notes
Loss of Mains		$\pm 2.5 \text{ Hz/s}$	80 - 100ms	Rate of Change of Frequency (ROCOF)

Table 3.35: Danish Loss of Mains Protection Settings for Embedded Generator Installations

Finland

In Finland, loss of mains protection is required. The protection is required to take three phase voltage and frequency into consideration. Generally the Under/over voltage and under/over frequency protection is used for loss of mains protection. However, a dedicated loss of mains relay can be used if the risk of islanding is deemed plausible.

France

In terms of loss of mains protection, no special requirements for this protection are made by the French. This approach was taken following the results of special studies which indicated that there is no risk of unintentional islanding because the “margin” is kept large enough to prevent it. In the event of loss of mains, it is perceived that the generator would be unable to maintain the island. However, transfer tripping may be used if there is a creditable risk of islanding.

Germany

Table 3.36 specifies the loss of mains requirements for generators connecting to the German system. It can be observed that the loss of mains requirement is specified in terms of a frequency range. In the event that the frequency varies by +/- 0.4%, the generator would be disconnected from the power system.

Interface Protection	Operating Settings (Hz)	Trip Time	Notes
Loss of Mains	49.8 – 50.2Hz	5 seconds	

Table 3.36: German Loss of Mains Protection Settings for Embedded Generator Installations

Norway

In Norway, Anti-islanding protection is required. Anti-islanding protection can either take the form of transfer tripping or ROCOF protection. Transfer tripping is used if tele-protection is available. Transfer tripping is considered to be a reliable form of anti-islanding protection and doesn't suffer from the stability issues associated with ROCOF or Vector Shift protection. If tele-protection is unavailable, ROCOF protection can be utilised with an operating time of 2 seconds.

Portugal

On observation of Portuguese rules and regulations, it was found that no specific requirements were made in terms of loss of mains protection.

Spain

In terms of unintentional islanding, BOE-219 states that “In the case of circuit breaker opening in the line, the plant connected to that line will not maintain the voltage in the grid”. The technical requirement goes on to state that “If it were possible for the plant

to maintain voltage (synchronous generator or self-excited asynchronous generator), a remote tripping system (Intertripping) will be installed so that the plant can be disconnected from its substation”. The technical requirement concludes with “Overhead lines with automatic re-closing will be equipped with the necessary devices to prevent the plant to reconnect until re-closing is firm”. At present, the utilisation of transfer tripping seems to be the most popular method of providing loss of mains functionality.

United Kingdom

Engineering Recommendation G59/1 states that the unplanned islanded operation of distributed generators is generally regarded as unsafe and undesirable. In order to prevent unplanned islanding, all distributed generators of capacity larger than 150kVA must be fitted with loss of mains protection, which aims to detect when a generator is islanded and to disconnect it from the network. Although there are various types of relay that can be used to detect Loss of Mains, the most commonly used form of Loss of Mains protection is the rate of change of frequency relay, usually referred to as a ROCOF relay. Alternatively, vector shift or other types of relay can be also used.

Changes to Engineering Recommendations G59/G75

The changes to G59/G75 Protection Requirements are as follows:

- Protection Settings for LV & HV Generation
 - Vector Shift Relay: $K1 \times 6^\circ$ ($K1 = 1$, Low Impedance Network or $K1 = 1.66 - 2$ for High Impedance Network)
 - ROCOF: $K1 \times 0.125\text{Hz}/z$ ($K1 = 1$, Low Impedance Network or $K1 = 1.66 - 2$ for High Impedance Network)
 - ROCOF: $K2 \times 0.125\text{Hz}/z$ ($K2 = 1$, Low Impedance Network or $K1 = 1.6$ for High Impedance Network)
- Medium Power Stations
 - Inter-tripping (preferred)

3.2.5.3 Discussion

The purpose of loss of mains protection at the interface of embedded generation sites is to detect the presence of an islanding condition and to immediately disconnect the generator from the islanded system. The most popular forms of loss of mains

protection are ROCOF and Vector Shift. Both ROCOF and Vector Shift are sensitive protection devices which are capable of detecting islanding events where the difference between load and generation are quite low. Unfortunately it is this in built sensitivity which makes this form of protection susceptible to mal operations. In the case of Denmark, it was found that ROCOF protection was responsible for the incorrect disconnection of CHP plants on the Danish distribution system. Furthermore, the Danish deemed it necessary to broaden the ROCOF settings to ensure greater stability for the CHP plants on the system. In the case of Ireland, the ROCOF settings can be considered very sensitive in that the ROCOF setting is set to detect for 0.4Hz/s deviations for synchronous machines and 0.55Hz/s for wind farms. The Irish system lacks any major interconnectivity and is a small system in comparison with the UK and other European countries. This means that faults in Tralee can result in voltage dips as far away as Dublin and Donegal. In the past when there was little or no embedded generation on the system, the problems associated with loss of mains protection would not have been perceived as an issue. However, with instances where > 1000MW of wind generation has been generating onto the system and instances where over 30% of the power generated on the system has been wind, the sudden loss of this generation due to mal-operations of the loss of mains protection would be unacceptable. Table 3.38 outlines proposed changes to the loss of mains requirements. A setting of +/- 2.5Hz/s would desensitise the loss of mains protection. The proposed setting would improve system stability and a timer setting of 0.7 seconds would ensure the loss of mains protection is compatible with fault ride through requirements. The disadvantage of desensitising the loss of mains protection is that for islanding conditions where by a small difference between load and generation exists, the loss of mains protection may not operate or experience delayed operation.

Interface Protection	Monitoring Details	Operating Settings (%)	Trip Time	Notes
Loss of Mains		+/- 2.5Hz/s	700ms	Rate of Change of Frequency (ROCOF)

Table 3.38: Proposed Loss of Mains Protection Settings for Embedded Generator Installations

Intertripping

In cases where a protection class communication channel exists between the utility and the embedded generator, intertripping should be utilised instead of ROCOF or Vector Shift protection. Intertripping is a secure method of implementing loss of mains protection. Intertripping works on the basis that when the utility circuit breaker opens, a trip command is sent to the embedded generator's circuit breaker thereby disconnecting the embedded generator from the system.

Load Vs Generation Balance

As previously stated, loss of mains protection is required to detect islanding events and to disconnect the generator in a rapid manner. However, a number of issues were raised in section 3.2.5.3 which shows that loss of mains protection is susceptible to spurious operation. One method of getting around the loss of mains requirement is network planning. For example, if the network planner was to ensure that when offering an embedded generator a connection agreement, the maximum conceivable output of the embedded generator never exceeded 50% of the minimum system load in the area in which the generator is connected, then the need for dedicated loss of mains protection is removed. In this case simple under/over voltage and under/over frequency protection would suffice.

Chapter 4

Approach and Methodology

4 Approach and Methodology

The approach and methodologies adopted for the system studies are outlined in this chapter. The chapter begins with an introduction to the simulation software used to study the impact of the interface protection requirements on embedded generation. This is followed by a brief discussion on the project structure and the characteristics of the test distribution system involved. Finally, an explanation of the methods used for the study will be presented.

4.1 PSS/E Simulation Software

PSS/E stands for Power System Simulator/Engineering and is developed by Siemens Power Technologies International (PTI). PSS/E is used primarily by utilities and consultancy firms to carry out power system studies. PSS/E has the ability to perform both phase vector and electromechanical simulations and has become the industrial standard within the power system industry. When an Independent Power Provider (IPP) applies for a grid connection in Ireland, the provision of a PSS/E model of the connecting generator is a mandatory requirement. The PSS/E model is necessary so that the TSO can quantify the response of the generator for long term and short term stability scenarios and ensure compliance with transmission/distribution code requirements. In the case of wind turbines, the wind turbine manufacturer provides a PSS/E model that is used by the utility for verification of the transmission and distribution grid codes. These models are not publically available and the vast majority of these models are bound by non-disclosure agreements. PSS/E contains a number of wind turbine models as standard which can be used to carry out dynamic studies.

PSS/E contains a number of modules which can be used to investigate the performance of a transmission system, industrial plant or a generator for both steady-state and dynamic conditions. PSS/E is capable of carrying out power flow studies, short circuit studies (balanced and unbalanced) as well as dynamic simulations.

Power Flow

The power flow module in PSS/E allows a user to carry out a power flow study where by the flow of active and reactive power in a network can be quantified. The software allows the user to choose the Gauss Siedel or Newton Rhapsion method to solve the power flow for a given system.

Power flow studies are important because they allow for the planning and future expansion of existing/non-existing power systems. A power flow study can also be used to optimise the design of power systems.

Dynamics

The dynamic simulation program contains all the functionality required for transient, dynamic and long term stability analysis. The dynamic modelling module is used to predict the performance of a generator/power system/industrial plant under a wide range of conditions and to identify any problems which could result in system instability.

4.1.1 PSS/E Wind Turbine Model

In version 32 of the PSS/E software, five wind turbine models exist. The model used as part of this study is the type 3 DFIG model. The dynamic model for the type 3 DFIG is constructed according to the recommendations made by GE Energy. When using this model for dynamic studies, a number of points must be considered which include:

- The model is adequate for bulk power system studies and is valid for positive sequence phasor time-domain simulations.
- The model assumes that the analysis is mainly focused on how the wind turbine-generator reacts to grid disturbances, such as faults on transmission system.
- Manufacturer specific PSS/E wind turbine models should be used where available in order to evaluate the performance of that model.

In order to construct a complete wind turbine model in PSS/E, four device models are required which are as follows:

- Generator/Convertor Model (WT3G1)
- Electrical Control Model (WT3E1)
- Mechanical Control Module (WT3T1)
- Pitch Control module (WT3P1)

The interaction of these models is shown in Figure 4.1.

It should be noted that the standard DFIG dynamic model in PSS/E does not fully represent the limitations of the DFIG wind turbine. There are a number of deficiencies in the model which include the lack of protection systems for the converter and rotor as well as the lack of under/over voltage protection and rotor current limits. Furthermore, the

upper and lower limitation in the voltage control loop will affect the voltage stability depending on how there configured. However, there is no direct relation between the maximum over load on the converters and the limitation in voltage control loop in the dynamic model.

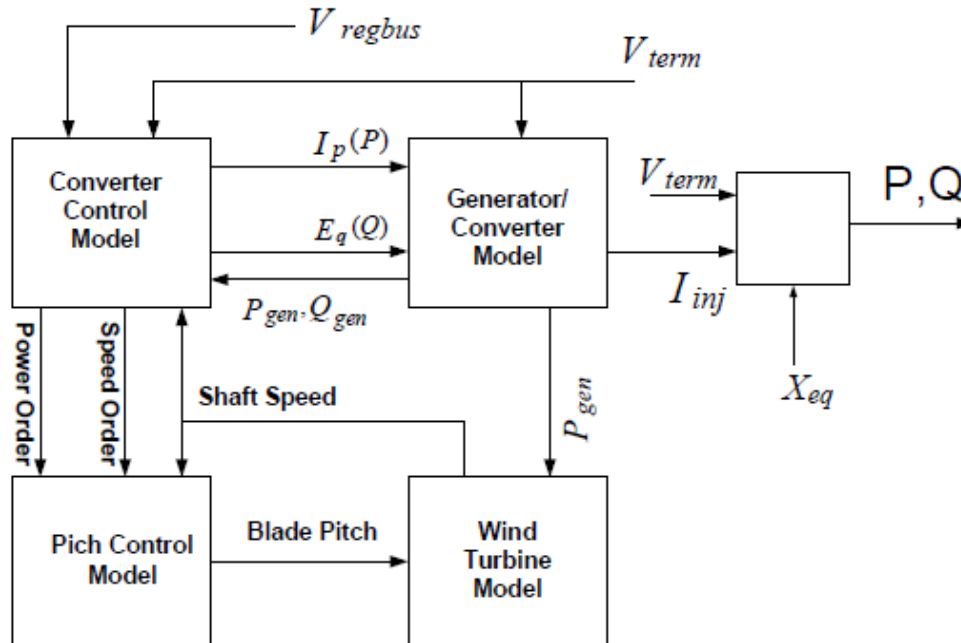

Figure 4.1: Wind Turbine Dynamic module

4.1.2 Generator/Convertor Model (WT3G1)

The generator/convertor model (WT3G1) is the equivalent model of the generator and the field converter and provides the interface between the wind turbine and the network. The primary difference between the WT3G1 model and conventional generator/convertor models is that the WT3G1 contains no mechanical variables for the rotor of the machine. These variables are contained in the WT3T1 module. Furthermore, the flux dynamics have been neglected in order to achieve a faster response to the high level commands received from the electrical controls through the converter.

Essentially, the generator is modelled as a current controlled source as shown in Appendix A. This current controlled source delivers the required current that must be injected to the grid in response to the flux and active current commands which are produced by the converter control model [3].

In the event of an over voltage condition, the amount of injected current to the grid is reduced to mitigate the over voltage condition. The two first-order low-pass filters represent the electronic control systems. Both filters have a time constant of 20 msec.

In reality, a phase locked loop (PLL) exists in the actual convertor controls of a wind turbine which is required to synchronise the generator rotor currents with the stator. However due to the particularly fast response of PLL dynamics relative to the generator/field converter time frame; it is not shown in the model.

The excitation current input is responsible for adjusting the output voltage. The active current input is responsible for determining the amount of active power which should be delivered to the grid. X'' represents the effective equivalent reactance of the generator. T represents the transfer function of the generator network. The vector diagram of the voltages and currents is shown in the wind generator model data sheet Appendix A.

4.1.3 Electrical Control Model (WT3E1)

The electrical control model is responsible for determining the amount of active and reactive power that must be delivered to the grid by the generator. The electrical convertor control model compares the measured active power (P_{gen}) with the ordered active power from the turbine model (P_{cmd}) and the measured reactive power at the wind turbine terminal (Q_{gen}) with the ordered reactive power (Q_{cmd}) from the reactive power control model. The electrical control model provides the required voltage and current commands and transmits these commands to the generator model by comparing the measured active and reactive power with the required amount of the active and reactive power.

The necessary control procedure for active power is specified in the turbine model. The model for reactive power control can be observed in the electrical model data sheet in Appendix A. The WT3E1 comes with three different options for reactive power control. The three options can be accessed by changing the position of the *varflg* switch. In position 1, the voltage magnitude at a particular bus is compared with the voltage reference magnitude, and this voltage is regulated by sending a reactive command to all of the wind turbine generators. The reference voltage magnitude is specified during the load flow study. In position -1 the reactive power command comes from power factor regulation and in position 0 the reactive power command is set to follow a certain amount of reference magnitude for reactive power [27]. The reactive power command is compared with reactive power measured at the terminal of the wind turbine in another model that is shown in the electrical model data sheet in Appendix A. The output of the PI controller is the reference voltage. The

reference voltage compared with voltage magnitude at the terminal point of the wind turbine generator to make the voltage command (E''_{qcmd}) for the generator model. The overall electrical model is presented in the electrical model data sheet in Appendix A.

4.1.4 Dynamic Model of the Infinite Grid

A thevenin equivalent can be used to represent a large power system. In order to represent the dynamic response of this simplified network, an appropriate dynamic model is required. For the purposes of the project, the infinite grid was represented using the following components available in PSS/E:

- Generator Model (GENROU)
- Excitation Control Model (SCRX)
- Governor Model (TGOV1)

The generator model (GENROU) represents a round rotor generator and was chosen to represent a power system dominated by conventional generation. The excitation model (SCRX) represents a simple excitation control system and was chosen to represent the response of a system again dominated by conventional generation. The governor model (TGOV1) represents a simple governor control system and was chosen to represent the response of a system dominated by conventional generation.

Ideally speaking, a full dynamic model of a power system should be used to determine the dynamic response of a system to a disturbance. While EirGrid publish the PSS/E power flow model of the Irish system, the dynamic model is not publically available. The reason for this is that the dynamic model contains technical details on a generator which can be commercially sensitive. Therefore it was necessary to make a number of assumptions based on previous experience to determine an appropriate dynamic model for the Infinite grid.

4.1.5 Voltage & Frequency Relay

PSS/E contains a customisable voltage (VTGTPA) and frequency (FRQTPA) relay which was utilised for simulating the interface protection. The documentation for both the voltage and frequency relay is contained in Appendix J.

4.2 Project Structure

The thesis was developed in a number of phases. Phase 1 of the thesis, the research phase looked at the growth of embedded generation in Ireland, the technologies

involved and the interface protection requirements outlined by different utilities around Europe. Phase 2 of this thesis focused on the system study aspect of the project. Finally, phase 3 highlights the conclusions and recommendations reached on the outcome of the research and system studies phases.

4.3 Test Distribution System

For the purposes of this project, two main test systems were developed which are as follows:

- Test Distribution System 1: Summer Night Valley
- Test Distribution System 2: Winter Peak

For each of the above test systems, three variations were derived for the 110kV fault simulations which were as follows:

- 15% Embedded Generation Output
- 50% Embedded Generation Output
- 100% Embedded Generation Output

For each of the test systems mentioned above, two variations were derived for the 38kV fault simulations and loss of mains simulations which were as follows:

- 15% Embedded Generation Output
- 100% Embedded Generation Output

In total eight test systems were created. The single line diagrams of the test systems involved can be found in Appendix C of this thesis.

4.3.1 Test Distribution System – 110kV Equivalent Impedance

For the purposes of this study, Tralee 110kV substation was chosen as the location to create the test system. Tralee was chosen on the basis that the Tralee network is located on the periphery of the Irish distribution system and contains significant amounts of embedded generation. The thevenin equivalent of the network behind Tralee 110kV system was obtained from the 2010 summer night valley and 2010 winter peak PSS/E models of the Irish System located on the EirGrid website [44]. The technical information for T141 and T142 110/38kV transformers was also taken from the PSS/E models located on the EirGrid website. The thevenin impedance for the summer night valley scenario represents a lightly loaded system with minimum generation dispatched. The thevenin impedance for the winter peak scenario

represents a heavily loaded system with maximum generation dispatched. The thevenin impedances used in this thesis can be found in Appendix E.

4.3.2 Test Distribution System – 38kV Network

The 38kV network emanating from the main 110kV node is composed of three radial feeds with five 38kV substations and one wind farm of 30MW in size. The technical information for the 38kV distribution network can be found in Appendix E. It should be noted that the 38kV network is not representative of the Tralee 38kV network but rather a typically 38kV network. For the 38kV network, the technical information for the 38kV feeders and 38/10kV transformers is based on typical network components.

4.3.3 Test Distribution System – 38kV Wind Farm

The technical information for the wind farm can be found in Appendix D of this thesis. The wind turbine chosen was the DFIG. The DFIG was chosen as the DFIG wind turbine is the most popular wind turbine on the Irish power system. The wind farm is composed of fifteen 2MW turbines with an MEC of 30MW. The technical information for the wind turbine, transformers and internal 20kV feeders is based on data outlined in [19] as well as typical wind farm data. The wind farm parameters (dynamic and steady state) were taken from [19]. Three wind farm dispatches were chosen for the 110kV fault simulations which were 15%, 50% and 100% output. Two wind farm dispatches were chosen for the 38kV fault simulation and the loss of mains simulation which were 15% and 100% output. It should be noted that 15% and 100% were chosen to represent minimum and maximum output of the wind farm. While 10% was originally chosen to represent minimum wind farm output, the use of 10% led to problems especially with the pitch control module (WT3P1) and the Generator/Convertor Model (WT3G1) in PSS/E

4.3.4 Test Distribution System – System Loading

Two sets of system loading were chosen. For the summer night valley scenario, a system loading was chosen to represent a lightly loaded system. For the winter peak scenario, a system loading was chosen to represent a heavily loaded system. The system dispatches can be observed in Appendix E of this thesis. It should be noted that both the summer and winter dispatches were chosen on the basis that islanding events could be simulated.

4.3.5 Protection Relays

For the purpose of this thesis, the voltage, frequency and loss of mains protection are assumed to have the following parameters:

Fault Location	Relay Pickup Time	Relay Drop Out Time	Reset Ratio
Voltage Protection	50ms	50ms	1.05
Frequency Protection	100ms	100ms	1.05
ROCOF Protection	200ms	-	0.6

Table 4.1: Relay Pickup Time

The above parameters are taken from the Siemens 7RW600 V3.0 manual [32].

4.3.6 Dynamic Model Setup PSS/E

On construction of the power flow model in PSS/E, a number steps must be taken before the model can be utilised for dynamic simulation. The steps which must be taken are as follows:

- Ensure power flow converges with minimum MW/MVAr mismatch
- Convert Loads and Generators
- Order Network for Matrix Operations (ORDR)
- Factorise Admittance Matrix (FACT)
- Solution for Switching Studies (TYSL)

On completion of the above steps, the power flow model can then be used for dynamic simulations.

4.4 Conditions for Analysis

In chapter 2 of this thesis, the different embedded generator technologies were discussed. It was found that synchronous generators produced significant amounts of fault current and provided inertia for the power system. For power system protection this has obvious advantages in terms of fault detection and discrimination. However, for induction generator based devices and full convertor connected devices, short circuit current contribution and inertia are of a major concern and can pose problems for power system protection as well as power system stability.

Chapter 3 outlined the interface protection requirements for Ireland and compared Irish requirements with international requirements. On the basis of this comparison, modifications to Irish interface requirements were proposed. The test system developed was used to test existing interface protection requirement and the proposed

modifications to the interface protection requirements and to determine the advantages and disadvantages with each set of requirements.

4.5 Methodology

The system analysis conducted through the PSS/E software will be composed of a number of scenarios. For the purposes of this project, two system conditions will be considered which are as follows:

- A System Fault
- A Loss of mains Event

Each of the above conditions was tested on the two main test systems which were developed as part of this thesis:

- Test Distribution System 1: Summer Night Valley
- Test Distribution System 2: Winter Peak

Furthermore, each of the above events was tested for different wind farm outputs.

- 15% Embedded Generation Output
- 50% Embedded Generation Output
- 100% Embedded Generation Output

4.5.1 Fault Analysis

Faults on a power system can be a minor or major event depending on fault type, duration and location. Power system faults can be either transient in nature or permanent. A power system fault can result in voltage dips on the system, loss of load or generation and can result in system instability if not cleared quickly enough. For the purposes of this thesis, the response of the wind farm was tested for Line to Line, Three Phase and Single Line to Ground faults on the 110kV busbar. Table 4.2 outlines the faults applied, fault clearance time and wind farm output tested on both of the distribution test systems.

Fault Location	Fault Type	Fault Clearance Time (Primary)	Wind Farm Output
110kV Busbar	Line to Line	0.1	15/50/100%
	Single Line to Ground	0.1	15/50/100%

Table 4.2: 110kV System Faults

The response of the wind farm was tested for Line to Line and three phase faults on the 38kV system. Single Line to Ground faults were not tested on the 38kV system as

the 38kV protection is not required to trip for Single line to Ground faults. The reason for this is that the 38kV system is earthed via a Peterson Coil. As such in the event of a Single Line to Ground fault, the Peterson Coil will theoretically reduce the fault current to zero amps at the fault site. Table 4.3 outlines the faults applied, fault clearance time and wind farm output tested on both of the distribution test systems.

Fault Location	Fault Type	Fault Location	Fault Clearance Time	Wind Farm Output
Substation B	Line to Line	38kV Busbar	0.5	15/100%
	Three Phase	38kV Busbar	0.5	15/100%
Substation C	Line to Line	38kV Busbar	0.5	15/100%
	Three Phase	38kV Busbar	0.5	15/100%
Substation D	Line to Line	38kV Busbar	0.5	15/100%
	Three Phase	38kV Busbar	0.5	15/100%
Substation E	Line to Line	38kV Busbar	0.5	15/100%
	Three Phase	38kV Busbar	0.5	15/100%
Substation F	Line to Line	38kV Busbar	0.5	15/100%
	Three Phase	38kV Busbar	0.5	15/100%

Table 4.3: 38kV System Faults

4.5.2 Loss of Mains Analysis

In Ireland, islanding is not allowed. In the event of islanding, all embedded generation must be disconnected from the islanded system. In order to detect islanding events, the embedded generator requires a protection device capable of detecting islanding.

For the purposes of this thesis, the response of the wind farm will be tested for islanding events. The following islanding scenarios were tested:

- Loss of 110/38kV substation
- Loss of 110/38kV substation + 38kV feeder (Substation B –C)
- Loss of 110/38kV substation + 38kV feeder (110/38KV Substation – B)
- Loss of 110/38kV substation + 38kV feeder (110/38KV Substation – D)
- Loss of 110/38kV substation + 38kV feeder (110/38KV Substation – F)
- Loss of 110/38kV substation + 38kV feeder (Substation D – E)
- Loss of 110/38kV substation + 38kV feeder (Substation F – Wind farm)

The aforementioned scenarios were tested on the two main test systems (summer night valley & winter peak) for 15%/50%/100% wind farm output.

Chapter 5

Results and Discussion

5 Results and Discussion

This chapter will present the results of the simulations performed using PSS/E based on the project structure outlined in Chapter 4. A brief description of the steps taken to perform the studies will be included along with graphs and tabulations displaying the effects of faults and loss of mains events on the performance of the embedded generator. Furthermore the impact of the interface protection requirements will also be assessed on the embedded generator and the advantages/disadvantages associated with the proposed embedded generator interface requirements explored. However, the chapter will first list the assumptions made during the implementation of each scenario.

5.1 Assumptions

As part of the system studies, a number of assumptions were made. The following assumptions will apply for all of the scenarios outlined in this thesis:

- Test System 1 and 2 are assumed to be balanced
- The system loads are assumed to be of constant MW and MVAR values
- The Base MVA is defined as 100MVA
- The wind turbines are assumed to have a 0.95 power factor
- The 110kV busbar will operate at 1.07pu or 117.7kV
- The Single Line to Ground fault is defined with a fault impedance of 0Ω (Worse Case Scenario)
- Wind farm Outputs
 - 10% = 15 x Wind turbines producing 0.2MW each
 - 15% = 15 x Wind turbines producing 0.3MW each
 - 50% = 15 x Wind turbines producing 1.0MW each
 - 100% = 15 x Wind turbines producing 2.0MW each
- The governor ramp rate is assumed to be 20MW per second
- The dynamic response of the power system is assumed (See Appendix E)
- The dynamic response of the wind farm as per data in appendix D
- Protection systems inside the wind farm have not been modelled
- A fault clearance time of 500ms (Relay + Breaker Operating Time) for 38kV faults

- A fault clearance time of 100ms (Relay + Breaker Operating Time) for 110kV faults
- The Statcom is assumed to operate within a +10/-5 MVARs characteristic with the ability to vary the output of the Statcom in 1MVAR steps

5.2 Simulation of Scenarios

This section of the thesis outlines the scenarios simulated in PSS/E and the steps take to simulate each of the scenarios outlined below.

5.2.1 110kV Fault Simulation

For the 110kV fault simulation both a line to line fault and a single line to ground fault were simulated on the 110kV busbar at the 110/38kV substation (Node 101) in PSS/E. Faults were plotted on the 110kV busbar for three different wind farm dispatches (15/50/100%) and two different system loadings (Summer Night Valley (SNV) and Winter Peak (WP)). The 110kV fault simulation was carried out in PSS/E using the following steps:

- Run the system for 1 second in steady state operation
- Apply fault on Node 101 for 100ms
- Clear fault after 100ms
- Observe system recovery over a 5 seconds window

5.2.2 38kV Fault Simulation

For the 38kV fault simulation both a line to line fault and a three phase fault were simulated on the following 38kV busbars:

- Substation B 38kV busbar (Node 601)
- Substation C 38kV busbar (Node 901)
- Substation D 38kV busbar (Node 501)
- Substation E 38kV busbar (Node 801)
- Substation F 38kV busbar (Node 401)

Single line to ground faults were not plotted as the 38kV system is earthed via a Peterson Coil and as such, protection installed on the 38kV system is not required to trip for single line to ground faults. However, the protection must indicate the presence of single line to ground faults.

Faults were plotted on each of the 38kV busbar above for two different wind farm dispatches (15/100%) and two different system loadings (SNV and WP). The 38kV fault simulation was carried out in PSS/E using the following steps:

- Run the system for 1 second in steady state operation
- Apply fault on 38kV busbar for 500ms
- Clear fault after 500ms
- Trip feeder on which the fault is located (simulate loss of load after fault event)
- Observe system recovery over a 5 seconds window

5.2.3 Loss of Mains Events

The following loss of mains events were simulated in PSS/E.

- Loss of 110/38kV substation
- Loss of 110/38kV substation + 38kV Feeder (B-C)
- Loss of 110/38kV Substation + 38kV Feeder (38kV Node – B)
- Loss of 110/38kV Substation + 38kV Feeder (38kV Node – D)
- Loss of 110/38kV substation + 38kV feeder (38kV Node – F)
- Loss of 110/38kV substation + 38kV feeder (D – E)
- Loss of 110/38kV substation + 38kV feeder (F – Wind farm)

The loss of mains events were simulated for two different wind farm dispatches (15/100%) and two different system loadings (SNV and WP). The loss of mains simulation was carried out in PSS/E using the following steps:

- Run the system for 1 second in steady state operation
- Trip the selected network
- Observe system response over a 5 seconds window

5.3 Power Flow Results

Power flow studies were conducted on the following eight test networks:

- Test Distribution System 1: Summer Night Valley - 10% EG output
- Test Distribution System 1: Summer Night Valley - 15% EG output
- Test Distribution System 1: Summer Night Valley - 50% EG output
- Test Distribution System 1: Summer Night Valley - 100% EG output
- Test Distribution System 2: Winter Peak - 10% EG output
- Test Distribution System 2: Winter Peak - 15% EG output

- Test Distribution System 2: Winter Peak - 50% EG output
- Test Distribution System 2: Winter Peak - 100% EG output

Power flow studies were conducted to obtain the initial conditions for dynamic simulation. The power flow studies highlight possible network issues and provide the bus voltage magnitudes, the bus voltage angles as well as the active and reactive power flow in the test systems. The power flow results obtained for the eight test networks are shown in Appendix F of this thesis. On observation of the power flow results, it can be observed that all bus voltages are within the voltage requirements outlined in the distribution code. Furthermore it can be observed that all 38kV busbars voltage magnitudes are within a +/- 6% tolerance for both summer night valley and winter peak scenarios. It was also observed that no transformer or distribution feeder is over loaded. Finally, the MW/MVAR mismatch between load and generation is within tolerance so as not to cause issues with the dynamic simulations.

5.4 Fault Simulation Results – 110kV Faults

5.4.1 Summer Night Valley Results

Tables 5.1 and 5.2 outline the results of the 110kV fault simulation. The voltage outputs from PSSSE can be found in appendix I of this thesis. It was observed that the voltage recovered quickly after the clearance of both the single line to ground and line to line faults. It was also observed that the wind farm interface protection did not operate.

Fault Location	Fault Type	Fault Clearance Time	Wind Farm Output	Wind farm Trip
110kV Busbar	Line to Line	0.1	15%	NO
		0.1	50%	NO
		0.1	100%	NO

Table 5.1: 110kV System Faults - Line to Line Fault – SNV

Fault Location	Fault Type	Fault Clearance Time	Wind Farm Output	Wind farm Trip
110kV Busbar	Single Line to Ground	0.1	15%	NO
		0.1	50%	NO
		0.1	100%	NO

Table 5.2: 110kV System Faults – Single Line to Ground Fault – SNV

5.4.2 Winter Peak Results

Tables 5.3 and 5.4 outline the results of the 110kV fault simulation. The voltage outputs from PSS/E can be found in appendix I of this thesis. It was observed that the voltage recovered quickly after the clearance of both the single line to ground and line to line faults. It was also observed that the wind farm interface protection did not operate.

Fault Location	Fault Type	Fault Clearance Time	Wind Farm Output	Wind Farm Trip
110kV Busbar	Line to Line	0.1	15%	NO
		0.1	50%	NO
		0.1	100%	NO

Table 5.3: 110kV System Faults - Line to Line Fault - WP

Fault Location	Fault Type	Fault Clearance Time	Wind Farm Output	Wind Farm Trip
110kV Busbar	Single Line to Ground	0.1	15%	NO
		0.1	50%	NO
		0.1	100%	NO

Table 5.4: 110kV System Faults – Single Line to Ground Fault – WP

5.5 Fault Simulation Results – 38kV Faults

5.5.1 Summer Night Valley Results

Table 5.5 and 5.6 outline the results of the 38kV fault simulation. The voltage outputs from PSS/E can be found in appendix I of this thesis. It was observed that while the existing interface protection requirements and the proposed interface protection requirements had a similar performance, the proposed interface settings allowed the wind farm to remain online for six cases where the wind farm should not have been tripped. In the case of the summer night valley scenarios, the proposed interface protection settings improved performance by 30% compared to the existing settings.

Fault Location	Fault Type	Fault Clearance Time	Wind Farm Output	Wind Farm Trip (Existing Interface Protection)	Wind Farm Trip (Proposed Interface Protection)
Substation B 38kV Busbar	Line to Line	0.5	15%	YES	NO
	Three Phase	0.5	15%	YES	NO
Substation C 38kV Busbar	Line to Line	0.5	15%	NO	NO
	Three Phase	0.5	15%	YES	NO
Substation D 38kV Busbar	Line to Line	0.5	15%	NO	NO
	Three Phase	0.5	15%	YES	NO
Substation E 38kV Busbar	Line to Line	0.5	15%	NO	NO
	Three Phase	0.5	15%	YES	NO
Substation F 38kV Busbar	Line to Line	0.5	15%	YES	YES
	Three Phase	0.5	15%	YES	YES

Table 5.5: 38kV System Faults – 15% Output - SNV

Fault Location	Fault Type	Fault Clearance Time	Wind Farm Output	Wind Farm Trip (Existing Interface Protection)	Wind Farm Trip (Proposed Interface Protection)
Substation B 38kV Busbar	Line to Line	0.5	100%	NO	NO
	Three Phase	0.5	100%	YES	YES
Substation C 38kV Busbar	Line to Line	0.5	100%	NO	NO
	Three Phase	0.5	100%	NO	NO
Substation D 38kV Busbar	Line to Line	0.5	100%	NO	NO
	Three Phase	0.5	100%	YES	NO
Substation E 38kV Busbar	Line to Line	0.5	100%	NO	NO
	Three Phase	0.5	100%	NO	NO
Substation F 38kV Busbar	Line to Line	0.5	100%	YES	YES
	Three Phase	0.5	100%	YES	YES

Table 5.6: 38kV System Faults - 100% Output - SNV

5.5.2 Winter Peak Results

Table 5.7 and 5.8 outline the results of the 38kV fault simulation. The voltage outputs from PSS/E can be found in appendix I of this thesis. It was observed that while the existing interface protection requirements and the proposed interface protection requirements had a similar performance, the proposed interface settings allowed the wind farm to remain online for four cases where the wind farm should not have been tripped. In the case of the winter peak scenarios, the proposed interface protection settings improved performance by 20% compared to the existing settings.

Fault Location	Fault Type	Fault Clearance Time	Wind Farm Output	Wind Farm Trip (Existing Interface Protection)	Wind Farm Trip (Proposed Interface Protection)
Substation B 38kV Busbar	Line to Line	0.5	15%	NO	NO
	Three Phase	0.5	15%	NO	NO
Substation C 38kV Busbar	Line to Line	0.5	15%	NO	NO
	Three Phase	0.5	15%	NO	NO
Substation D 38kV Busbar	Line to Line	0.5	15%	NO	NO
	Three Phase	0.5	15%	YES	NO
Substation E 38kV Busbar	Line to Line	0.5	15%	NO	NO
	Three Phase	0.5	15%	NO	NO
Substation F 38kV Busbar	Line to Line	0.5	15%	YES	YES
	Three Phase	0.5	15%	YES	YES

Table 5.7: 38kV System Faults – 15% Output - WP

Fault Location	Fault Type	Fault Clearance Time	Wind Farm Output	Wind Farm Trip (Existing Interface Protection)	Wind Farm Trip (Proposed Interface Protection)
Substation B 38kV Busbar	Line to Line	0.5	100%	YES	NO
	Three Phase	0.5	100%	YES	NO
Substation C 38kV Busbar	Line to Line	0.5	100%	NO	NO
	Three Phase	0.5	100%	NO	NO
Substation D 38kV Busbar	Line to Line	0.5	100%	YES	NO
	Three Phase	0.5	100%	YES	YES
Substation E 38kV Busbar	Line to Line	0.5	100%	NO	NO
	Three Phase	0.5	100%	NO	NO
Substation F 38kV Busbar	Line to Line	0.5	100%	YES	YES
	Three Phase	0.5	100%	YES	YES

Table 5.8: 38kV System Faults - 100% Output - WP

5.6 Loss of Mains Analysis

5.6.1 Loss of 110/38kV Substation

Summer Night Valley Results

Tables 5.9 and 5.10 below outline the results obtained from PSS/E for loss of the main 110/38kV substation. For the 15% wind farm output it was observed that both the existing interface protection requirements and the proposed interface protection requirements detected the islanding event and tripped the wind farm with similar performance.

For the 100% wind farm output it was observed that both the existing interface protection requirements and the proposed interface protection requirements detected the islanding event and tripped the wind farm. However, in the case of the proposed interface protection requirements, only the under voltage protection operated. It should also be noted that the proposed settings would be 500ms slower tripping the wind farm compared to existing interface protection.

Interface Protection	Wind Farm Trip (Existing Interface Protection)	Wind Farm Trip (Proposed Interface Protection)	Operating Time (Existing Interface Protection)	Operating Time (Proposed Interface Protection)
Under Voltage	YES	YES	0.5 Seconds	1 Second
Over Voltage	NO	NO	-	-
Under Frequency	YES	YES	0.5 Seconds	0.5 Seconds
Over Frequency	NO	NO	-	-
ROCOF	YES	YES	0.5 Seconds	0.7 Seconds

Table 5.9: Loss of 110kV Substation– 15% Output - SNV

Interface Protection	Wind Farm Trip (Existing Interface Protection)	Wind Farm Trip (Proposed Interface Protection)	Operating Time (Existing Interface Protection)	Operating Time (Proposed Interface Protection)
Under Voltage	YES	YES	0.5 Seconds	1 Second
Over Voltage	NO	NO	-	-
Under Frequency	NO	NO	-	-
Over Frequency	Yes	NO	0.5 Seconds	-
ROCOF	YES	NO	0.5 Seconds	-

Table 5.10: Loss of 110kV Substation– 100% Output - SNV

Winter Peak Results

Tables 5.11 and 5.12 below outline the results obtained from PSS/E for loss of the main 110/38kV substation. For the 15% wind farm output it was observed that both the existing interface protection requirements and the proposed interface protection requirements detected the islanding event and tripped the wind farm with similar performance.

For the 100% wind farm output it was observed that both the existing interface protection requirements and the proposed interface protection requirements detected the islanding event and tripped the wind farm with similar performance.

Interface Protection	Wind Farm Trip (Existing Interface Protection)	Wind Farm Trip (Proposed Interface Protection)	Operating Time (Existing Interface Protection)	Operating Time (Proposed Interface Protection)
Under Voltage	YES	YES	0.5 Seconds	1 Second
Over Voltage	NO	NO	-	-
Under Frequency	YES	YES	0.5 Seconds	0.5 Seconds
Over Frequency	NO	NO	-	-
ROCOF	YES	YES	0.5 Seconds	0.7 Seconds

Table 5.11: Loss of 110kV Substation– 15% Output - WP

Interface Protection	Wind Farm Trip (Existing Interface Protection)	Wind Farm Trip (Proposed Interface Protection)	Operating Time (Existing Interface Protection)	Operating Time (Proposed Interface Protection)
Under Voltage	YES	YES	0.5 Seconds	1 Second
Over Voltage	NO	NO	-	-
Under Frequency	YES	YES	0.5 Seconds	0.5 Seconds
Over Frequency	NO	NO	-	-
ROCOF	YES	YES	0.5 Seconds	0.7 Seconds

Table 5.12: Loss of 110kV Substation– 100% Output - WP

5.6.2 Loss of 110/38kV Substation + 38kV Feeder (B – C)

Summer Night Valley Results

Tables 5.13 and 5.14 below outline the results obtained from PSS/E for loss of the main 110/38kV substation and loss of the 38kV feeder between substation B and C. For the 15% wind farm output it was observed that both the existing interface protection requirements and the proposed interface protection requirements detected the islanding event and tripped the wind farm with similar performance.

For the 100% wind farm output it was observed that both the existing interface protection requirements and the proposed interface protection requirements detected the islanding event and tripped the wind farm. However, in the case of the proposed interface protection requirements, only the under voltage protection operated. It should also be noted that the proposed settings would be 500ms slower tripping the wind farm compared to existing interface protection.

Interface Protection	Wind Farm Trip (Existing Interface Protection)	Wind Farm Trip (Proposed Interface Protection)	Operating Time (Existing Interface Protection)	Operating Time (Proposed Interface Protection)
Under Voltage	YES	YES	0.5 Seconds	1 Second
Over Voltage	NO	NO	-	-
Under Frequency	YES	YES	0.5 Seconds	0.5 Seconds
Over Frequency	NO	NO	-	-
ROCOF	YES	YES	0.5 Seconds	0.7 Seconds

Table 5.13: Loss of 110kV Substation + Feeder B - C – 15% Output - SNV

Interface Protection	Wind Farm Trip (Existing Interface Protection)	Wind Farm Trip (Proposed Interface Protection)	Operating Time (Existing Interface Protection)	Operating Time (Proposed Interface Protection)
Under Voltage	YES	YES	0.5 Seconds	1 Second
Over Voltage	NO	NO	-	-
Under Frequency	YES	NO	0.5 Seconds	-
Over Frequency	NO	NO	-	-
ROCOF	YES	NO	0.5 Seconds	-

Table 5.14: Loss of 110kV Substation + Feeder B - C – 100% Output - SNV

Winter Peak Results

Tables 5.15 and 5.16 below outline the results obtained from PSS/E for loss of the main 110/38kV substation and loss of the 38kV feeder between substation B and C. For the 15% wind farm output it was observed that both the existing interface protection requirements and the proposed interface protection requirements detected the islanding event and tripped the wind farm with similar performance.

For the 100% wind farm output it was observed that both the existing interface protection requirements and the proposed interface protection requirements detected the islanding event and tripped the wind farm. However, in the case of the proposed interface protection requirements, only the under voltage and under frequency protection operated.

Interface Protection	Wind Farm Trip (Existing Interface Protection)	Wind Farm Trip (Proposed Interface Protection)	Operating Time (Existing Interface Protection)	Operating Time (Proposed Interface Protection)
Under Voltage	YES	YES	0.5 Seconds	1 Second
Over Voltage	NO	NO	-	-
Under Frequency	YES	YES	0.5 Seconds	0.5 Seconds
Over Frequency	NO	NO	-	-
ROCOF	YES	YES	0.5 Seconds	0.7 Seconds

Table 5.15: Loss of 110kV Substation + Feeder B - C – 15% Output - WP

Interface Protection	Wind Farm Trip (Existing Interface Protection)	Wind Farm Trip (Proposed Interface Protection)	Operating Time (Existing Interface Protection)	Operating Time (Proposed Interface Protection)
Under Voltage	YES	YES	0.5 Seconds	1 Second
Over Voltage	NO	NO	-	-
Under Frequency	YES	YES	0.5 Seconds	0.5 Seconds
Over Frequency	NO	NO	-	-
ROCOF	YES	NO	0.5 Seconds	-

Table 5.16: Loss of 110kV Substation + Feeder B - C – 100% Output - WP

5.6.3 Loss of 110/38kV Substation + 38kV Feeder (38kV Node – B) Summer Night Valley Results

Tables 5.17 and 5.18 below outline the results obtained from PSS/E for loss of the main 110/38kV substation and loss of the 38kV feeder between the 110kV substation and substation B. For the 15% wind farm output it was observed that both the existing interface protection requirements and the proposed interface protection requirements detected the islanding event and tripped the wind farm with similar performance.

For the 100% wind farm output it was observed that both the existing interface protection requirements and the proposed interface protection requirements detected the islanding event and tripped the wind farm. However, in the case of the proposed interface protection requirements, only the under voltage protection operated with a tripping time 2.5 seconds slower than the existing interface protection clearance time.

Interface Protection	Wind Farm Trip (Existing Interface Protection)	Wind Farm Trip (Proposed Interface Protection)	Operating Time (Existing Interface Protection)	Operating Time (Proposed Interface Protection)
Under Voltage	YES	YES	0.5 Seconds	1 Second
Over Voltage	NO	NO	-	-
Under Frequency	NO	NO	-	-
Over Frequency	NO	NO	-	-
ROCOF	YES	YES	0.5 Seconds	0.7 Seconds

Table 5.17: Loss of 110kV Substation + Feeder B – 15% Output - SNV

Interface Protection	Wind Farm Trip (Existing Interface Protection)	Wind Farm Trip (Proposed Interface Protection)	Operating Time (Existing Interface Protection)	Operating Time (Proposed Interface Protection)
Under Voltage	NO	YES	-	3 Seconds
Over Voltage	NO	NO	-	-
Under Frequency	NO	NO	-	-
Over Frequency	YES	NO	0.5 Seconds	-
ROCOF	YES	NO	0.5 Seconds	-

Table 5.18: Loss of 110kV Substation + Feeder B – 100% Output - SNV

Winter Peak Results

Tables 5.19 and 5.20 below outline the results obtained from PSS/E for loss of the main 110/38kV substation and loss of the 38kV feeder between the 110kV substation and substation B. For the 15% wind farm output it was observed that both the existing interface protection requirements and the proposed interface protection requirements detected the islanding event and tripped the wind farm.

For the 100% wind farm output it was observed that both the existing interface protection requirements and the proposed interface protection requirements detected the islanding event and tripped the wind farm with similar performance.

Interface Protection	Wind Farm Trip (Existing Interface Protection)	Wind Farm Trip (Proposed Interface Protection)	Operating Time (Existing Interface Protection)	Operating Time (Proposed Interface Protection)
Under Voltage	YES	YES	0.5 Seconds	1 Second
Over Voltage	NO	NO	-	-
Under Frequency	YES	YES	0.5 Seconds	0.5 Seconds
Over Frequency	NO	NO	-	-
ROCOF	YES	YES	0.5 Seconds	0.7 Seconds

Table 5.19: Loss of 110kV Substation + Feeder B – 15% Output - WP

Interface Protection	Wind Farm Trip (Existing Interface Protection)	Wind Farm Trip (Proposed Interface Protection)	Operating Time (Existing Interface Protection)	Operating Time (Proposed Interface Protection)
Under Voltage	YES	YES	0.5 Seconds	1 Second
Over Voltage	NO	NO	-	-
Under Frequency	YES	YES	0.5 Seconds	0.5 Seconds
Over Frequency	NO	NO	-	-
ROCOF	YES	YES	0.5 Seconds	0.7 Seconds

Table 5.20: Loss of 110kV Substation + Feeder B – 100% Output - WP

5.6.4 Loss of 110/38kV Substation + 38kV Feeder (38kV Node – D) Summer Night Valley Results

Tables 5.21 and 5.22 below outline the results obtained from PSS/E for loss of the main 110/38kV substation and loss of the 38kV feeder between the 110kV substation and substation D. For the 15% wind farm output it was observed that both the existing interface protection requirements and the proposed interface protection requirements detected the islanding event and tripped the wind farm. However, it was observed that the undervoltage protection was 500ms quicker compared to existing requirements. For the 100% wind farm output it was observed that both the existing interface protection requirements and the proposed interface protection requirements detected the islanding event and tripped the wind farm. However, the proposed interface protection settings were 19.5 seconds slower clearing the fault.

Interface Protection	Wind Farm Trip (Existing Interface Protection)	Wind Farm Trip (Proposed Interface Protection)	Operating Time (Existing Interface Protection)	Operating Time (Proposed Interface Protection)
Under Voltage	YES	YES	3.5 Seconds	3 Seconds
Over Voltage	NO	NO	-	-
Under Frequency	NO	NO	-	-
Over Frequency	NO	NO	-	-
ROCOF	YES	YES	0.5 Seconds	0.7 Seconds

Table 5.21: Loss of 110kV Substation + Feeder D – 15% Output - SNV

Interface Protection	Wind Farm Trip (Existing Interface Protection)	Wind Farm Trip (Proposed Interface Protection)	Operating Time (Existing Interface Protection)	Operating Time (Proposed Interface Protection)
Under Voltage	NO	NO	-	-
Over Voltage	NO	NO	-	-
Under Frequency	NO	NO	-	-
Over Frequency	YES	YES	0.5 Seconds	20 Seconds
ROCOF	YES	NO	0.5 Seconds	-

Table 5.22: Loss of 110kV Substation + Feeder D – 100% Output - SNV

Winter Peak Results

Tables 5.23 and 5.24 below outline the results obtained from PSS/E for loss of the main 110/38kV substation and loss of the 38kV feeder between the 110kV substation and substation D. For the 15% wind farm output it was observed that both the existing interface protection requirements and the proposed interface protection requirements detected the islanding event and tripped the wind farm with similar performance.

For the 100% wind farm output it was observed that both the existing interface protection requirements and the proposed interface protection requirements detected the islanding event and tripped the wind farm. However, in the case of the proposed interface protection requirements, only the under voltage protection operated. It should also be noted that the proposed settings would be 500ms slower tripping the wind farm compared to existing interface protection.

Interface Protection	Wind Farm Trip (Existing Interface Protection)	Wind Farm Trip (Proposed Interface Protection)	Operating Time (Existing Interface Protection)	Operating Time (Proposed Interface Protection)
Under Voltage	YES	YES	0.5 Seconds	1 Second
Over Voltage	NO	NO	-	-
Under Frequency	YES	YES	0.5 Seconds	0.5 Seconds
Over Frequency	NO	NO	-	-
ROCOF	YES	YES	0.5 Seconds	0.7 Seconds

Table 5.23: Loss of 110kV Substation + Feeder D – 15% Output - WP

Interface Protection	Wind Farm Trip (Existing Interface Protection)	Wind Farm Trip (Proposed Interface Protection)	Operating Time (Existing Interface Protection)	Operating Time (Proposed Interface Protection)
Under Voltage	YES	YES	0.5 Seconds	1 Second
Over Voltage	NO	NO	-	-
Under Frequency	NO	NO	-	-
Over Frequency	YES	NO	0.5 Seconds	-
ROCOF	YES	NO	0.5 Seconds	-

Table 5.24: Loss of 110kV Substation + Feeder D – 100% Output - WP

5.6.5 Loss of 110/38kV substation + 38kV feeder (38kV Node – F)

Summer Night Valley Results

Tables 5.25 and 5.26 below outline the results obtained from PSS/E for loss of the main 110/38kV substation and loss of the 38kV feeder between the 110kV substation and substation F. For the 15% wind farm output it was observed that both the existing interface protection requirements and the proposed interface protection requirements detected the islanding event and tripped the wind farm. However, the under voltage protection only operated for the proposed interface protection settings.

For the 100% wind farm output it was observed that both the existing interface protection requirements and the proposed interface protection requirements detected the islanding event and tripped the wind farm with similar performance.

Interface Protection	Wind Farm Trip (Existing Interface Protection)	Wind Farm Trip (Proposed Interface Protection)	Operating Time (Existing Interface Protection)	Operating Time (Proposed Interface Protection)
Under Voltage	NO	YES	-	3.0
Over Voltage	NO	NO	-	-
Under Frequency	NO	NO	-	-
Over Frequency	NO	NO	-	-
ROCOF	YES	YES	0.5 Seconds	0.7 Seconds

Table 5.25: Loss of 110kV Substation + Feeder F – 15% Output - SNV

Interface Protection	Wind Farm Trip (Existing Interface Protection)	Wind Farm Trip (Proposed Interface Protection)	Operating Time (Existing Interface Protection)	Operating Time (Proposed Interface Protection)
Under Voltage	NO	NO	-	-
Over Voltage	NO	NO	-	-
Under Frequency	NO	NO	-	-
Over Frequency	YES	YES	0.5 Seconds	0.5 Seconds
ROCOF	YES	YES	0.5 Seconds	0.7 Seconds

Table 5.26: Loss of 110kV Substation + Feeder F – 100% Output - SNV

Winter Peak Results

Tables 5.27 and 5.28 below outline the results obtained from PSS/E for loss of the main 110/38kV substation and loss of the 38kV feeder between the 110kV substation and substation F. For the 15% wind farm output it was observed that both the existing interface protection requirements and the proposed interface protection requirements detected the islanding event and tripped the wind farm.

For the 100% wind farm output it was observed that both the existing interface protection requirements and the proposed interface protection requirements detected the islanding event and tripped the wind farm.

Interface Protection	Wind Farm Trip (Existing Interface Protection)	Wind Farm Trip (Proposed Interface Protection)	Operating Time (Existing Interface Protection)	Operating Time (Proposed Interface Protection)
Under Voltage	YES	YES	0.5 Seconds	1 Second
Over Voltage	NO	NO	-	-
Under Frequency	NO	NO	-	-
Over Frequency	NO	NO	-	-
ROCOF	YES	YES	0.5 Seconds	0.7 Seconds

Table 5.27: Loss of 110kV Substation + Feeder F – 15% Output - WP

Interface Protection	Wind Farm Trip (Existing Interface Protection)	Wind Farm Trip (Proposed Interface Protection)	Operating Time (Existing Interface Protection)	Operating Time (Proposed Interface Protection)
Under Voltage	NO	NO	-	-
Over Voltage	NO	NO	-	-
Under Frequency	NO	NO	-	-
Over Frequency	YES	YES	0.5 Seconds	20 Seconds
ROCOF	YES	YES	0.5 Seconds	0.7 Seconds

Table 5.28: Loss of 110kV Substation + Feeder F – 100% Output - WP

5.6.6 Loss of 110/38kV substation + 38kV feeder (D – E)

Summer Night Valley Results

Tables 5.29 and 5.30 below outline the results obtained from PSS/E for loss of the main 110/38kV substation and loss of the 38kV feeder between the 110kV substation and substation feeder D - E. For the 15% wind farm output it was observed that both the existing interface protection requirements and the proposed interface protection requirements detected the islanding event and tripped the wind farm with similar performance.

For the 100% wind farm output it was observed that both the existing interface protection requirements and the proposed interface protection requirements detected the islanding event and tripped the wind farm. However, in the case of the proposed interface protection requirements, only the under voltage protection operated. It should also be noted that the proposed settings would be 500ms slower tripping the wind farm compared to existing interface protection.

Interface Protection	Wind Farm Trip (Existing Interface Protection)	Wind Farm Trip (Proposed Interface Protection)	Operating Time (Existing Interface Protection)	Operating Time (Proposed Interface Protection)
Under Voltage	YES	YES	0.5 Seconds	1 Second
Over Voltage	NO	NO	-	-
Under Frequency	NO	NO	-	-
Over Frequency	NO	NO	-	-
ROCOF	YES	YES	0.5 Seconds	0.7 Seconds

Table 5.29: Loss of 110kV Substation + Feeder D – E – 15% Output - SNV

Interface Protection	Wind Farm Trip (Existing Interface Protection)	Wind Farm Trip (Proposed Interface Protection)	Operating Time (Existing Interface Protection)	Operating Time (Proposed Interface Protection)
Under Voltage	YES	YES	0.5 Seconds	1 Second
Over Voltage	NO	NO	-	-
Under Frequency	NO	NO	-	-
Over Frequency	YES	NO	0.5 Seconds	-
ROCOF	YES	NO	0.5 Seconds	-

Table 5.30: Loss of 110kV Substation + Feeder D – E – 100% Output - SNV

Winter Peak Results

Tables 5.31 and 5.32 below outline the results obtained from PSS/E for loss of the main 110/38kV substation and loss of the 38kV feeder between the 110kV substation and substation feeder D - E. For the 15% wind farm output it was observed that both the existing interface protection requirements and the proposed interface protection requirements detected the islanding event and tripped the wind farm.

For the 100% wind farm output it was observed that both the existing interface protection requirements and the proposed interface protection requirements detected the islanding event and tripped the wind farm.

Interface Protection	Wind Farm Trip (Existing Interface Protection)	Wind Farm Trip (Proposed Interface Protection)	Operating Time (Existing Interface Protection)	Operating Time (Proposed Interface Protection)
Under Voltage	YES	YES	0.5 Seconds	1 Second
Over Voltage	NO	NO	-	-
Under Frequency	YES	YES	0.5 Seconds	0.5 Seconds
Over Frequency	NO	NO	-	-
ROCOF	YES	YES	0.5 Seconds	0.7 Seconds

Table 5.31: Loss of 110kV Substation + Feeder D – E – 15% Output - WP

Interface Protection	Wind Farm Trip (Existing Interface Protection)	Wind Farm Trip (Proposed Interface Protection)	Operating Time (Existing Interface Protection)	Operating Time (Proposed Interface Protection)
Under Voltage	YES	YES	0.5 Seconds	1 Second
Over Voltage	NO	NO	-	-
Under Frequency	YES	YES	0.5 Seconds	0.5 Seconds
Over Frequency	NO	NO	-	-
ROCOF	YES	YES	0.5 Seconds	0.7 Seconds

Table 5.32: Loss of 110kV Substation + Feeder D – E – 100% Output - WP

5.6.7 Loss of 110/38kV substation + 38kV feeder (F – Wind farm)

Summer Night Valley Results

Tables 5.33 and 5.34 below outline the results obtained from PSS/E for loss of the main 110/38kV substation and loss of the 38kV feeder between the 110kV substation and substation feeder F - Wind farm. For the 15% wind farm output it was observed that both the existing interface protection requirements and the proposed interface protection requirements detected the islanding event and tripped the wind farm. However, in the case of the proposed interface protection settings, only the ROCOF protection operated.

For the 100% wind farm output it was observed that both the existing interface protection requirements and the proposed interface protection requirements detected the islanding event and tripped the wind farm with similar performance.

Interface Protection	Wind Farm Trip (Existing Interface Protection)	Wind Farm Trip (Proposed Interface Protection)	Operating Time (Existing Interface Protection)	Operating Time (Proposed Interface Protection)
Under Voltage	NO	NO	-	-
Over Voltage	NO	NO	-	-
Under Frequency	NO	NO	-	-
Over Frequency	YES	NO	0.5 Seconds	-
ROCOF	YES	YES	0.5 Seconds	0.7 Seconds

Table 5.33: Loss of 110kV Substation + Feeder F – Wind farm – 15% Output - SNV

Interface Protection	Wind Farm Trip (Existing Interface Protection)	Wind Farm Trip (Proposed Interface Protection)	Operating Time (Existing Interface Protection)	Operating Time (Proposed Interface Protection)
Under Voltage	NO	NO	-	-
Over Voltage	NO	NO	-	-
Under Frequency	NO	NO	-	-
Over Frequency	YES	YES	0.5 Seconds	0.5 Seconds
ROCOF	YES	YES	0.5 Seconds	0.7 Seconds

Table 5.34: Loss of 110kV Substation + Feeder F – Wind farm – 100% Output - SNV

Winter Peak Results

Tables 5.35 and 5.36 below outline the results obtained from PSS/E for loss of the main 110/38kV substation and loss of the 38kV feeder between the 110kV substation and substation feeder F - Wind farm. For the 15% wind farm output it was observed that both the existing interface protection requirements and the proposed interface protection requirements detected the islanding event and tripped the wind farm. However, in the case of the proposed interface protection settings, only the ROCOF protection operated.

For the 100% wind farm output it was observed that both the existing interface protection requirements and the proposed interface protection requirements detected the islanding event and tripped the wind farm with similar performance.

Interface Protection	Wind Farm Trip (Existing Interface Protection)	Wind Farm Trip (Proposed Interface Protection)	Operating Time (Existing Interface Protection)	Operating Time (Proposed Interface Protection)
Under Voltage	NO	NO	-	-
Over Voltage	NO	NO	-	-
Under Frequency	NO	NO	-	-
Over Frequency	YES	NO	0.5 Seconds	-
ROCOF	YES	YES	0.5 Seconds	0.7 Seconds

Table 5.35: Loss of 110kV Substation + Feeder F – Wind farm – 15% Output - WP

Interface Protection	Wind Farm Trip (Existing Interface Protection)	Wind Farm Trip (Proposed Interface Protection)	Operating Time (Existing Interface Protection)	Operating Time (Proposed Interface Protection)
Under Voltage	NO	NO	-	-
Over Voltage	NO	NO	-	-
Under Frequency	NO	NO	-	-
Over Frequency	YES	YES	0.5 Seconds	0.5 Seconds
ROCOF	YES	YES	0.5 Seconds	0.7 Seconds

Table 5.36: Loss of 110kV Substation + Feeder F – Wind farm – 100% Output - WP

5.7 Findings

Both the fault and loss of mains simulations in PSS/E highlighted the main issues associated with choosing interface protection settings. From both the 110kV and 38kV fault simulations it was observed that changing the interface protection requirements to the settings shown in Tables 5.37, 5.38 and 5.41 resulted in improved performance of the wind farm. Out of the forty faults simulated, it was found that the proposed interface protection settings improved performance for ten of the cases. This is a 25% improvement in performance. The advantages of using the settings outlined in Tables 5.37, 5.38 and 5.41 is that these settings are compatible with transmission and distribution code requirements especially voltage and frequency requirements. Furthermore, the proposed settings allow the power system extra time to recover before tripping the embedded generator.

However, the loss of mains analysis highlighted the main issues associated with loosening protection settings which is delayed tripping for genuine fault scenarios. It was observed that the proposed settings were anywhere between 200ms – 20 seconds slower in certain cases compared with existing interface protection requirements.

With anywhere between 3000-5000MW of renewable generation connecting to the system over the next 10 years, it is important to ensure that embedded generation is not needlessly disconnected from the system. The settings presented in Tables 5.37 – 5.41 strike a balance between improved performance and rapid fault clearance.

Interface Protection	Monitoring Details	Operating Settings (%)	Operating Settings (Hz)	Trip Time
Under Frequency	2 phases (minimum)	$\leq -6\%$	47.0Hz	0.5 seconds
		$\leq -5\%$	47.5Hz	20 seconds
Over Frequency	2 phases (minimum)	$\geq +4\%$	52.0Hz	20 seconds
		$\geq +5\%$	52.5Hz	0.5 seconds

Table 5.37: Recommended Frequency Protection Settings for Embedded Generator Installations

Interface Protection	Monitoring Details	Operating Settings (%)	Operating Settings (pu)	Trip Time
Under Voltage ^{***}	3 phases	< -13%	0.87	3.0 seconds
		< -20%	0.80	1.0 second
Under Voltage ^{†††}	3 phases	< -13%	0.87	2.5 seconds
		< -50%	0.50	1.85 seconds
Over Voltage	3 phases	> +13%	1.13	0.7 seconds

Table 5.38: Recommended Voltage Protection Settings for Embedded Generator Installations

Interface Protection	Monitoring Details	Operating Settings (%)	Trip Time	Notes
Directional Overcurrent ^{‡‡‡}	ESB Networks Supply 3ph	≤ 50%	< 0.5 seconds	No- Export Generators
		ESB Networks Supply 3ph	≤ 120%	< 0.5 seconds

Table 5.39: Recommended Irish Overcurrent Protection Settings for Embedded Generator Installations

Interface Protection	Monitoring Details	Operating Settings (%)	Trip Time
Earth Fault	ESB Networks MV or 38kV Supply	30% NVD ^{§§§}	Alarm (Indicate Only)

Table 5.40: Recommended Irish Earth Fault Protection Settings for Embedded Generator Installations

Interface Protection	Monitoring Details	Operating Settings (%)	Trip Time	Notes
Loss of Mains		+/- 2.5Hz/s	700ms	Rate of Change of Frequency (ROCOF)

Table 5.41: Recommended Loss of Mains Protection Settings for Embedded Generator Installations

*** Wind Farm Types B,C,D and E

††† Wind Farm Type A

‡‡‡ May not be required if generator rating is < 1MVA @ MV PCC or < 200kVA @ LV PCC

§§§ Neutral Voltage Displacement

Chapter 6

Conclusion

6 Conclusion

6.1 Conclusions

The aim of this thesis was to evaluate the impact of existing interface protection requirements on the stability of wind farms and to propose appropriate changes to these interface protection requirements. In order to carry out this objective it was necessary to carry out a review of international practice in regards to interface protection requirements. From the review it was found that many utilities implemented multi stage voltage and frequency protection. On the basis of the review, the utilisation of multi stage frequency protection was put forward with settings that would ensure compatibility with distribution code requirements for frequency. The implementation of multi stage frequency protection would not be seen as a costly introduction as most modern devices are capable of implementing multi stage protection as standard.

The utilisation of multi stage voltage protection was also put forward. The benefit of multi stage voltage protection is that the settings can be tailored to provide rapid clearance for close in faults and delayed tripping for remote faults. Furthermore, with under voltage protection, the settings can be chosen to ensure compatibility with the fault ride through requirements outlined in the distribution code. Again this would not be seen as a costly introduction as most voltage protection devices allow for multi stage voltage protection as standard.

In regards to the overcurrent protection requirement, it was found that for synchronous machines the use of overcurrent protection was justifiable in that synchronous machines can provide adequate fault current contribution to be able to discriminate between fault and load conditions. With DFIG and Full Converter connected technologies (Type 4), adequate fault current contribution (magnitude and duration) cannot be guaranteed to be able to discriminate decisively between load and fault conditions. In the case of Induction generator and full converter technology, the overcurrent protection requirement could be dropped and replaced with duplicate undervoltage protection.

For earth fault protection requirements, it is recommended that the NVD protection should be set to alarm only for 38kV applications. The 38kV system in Ireland is earthed via a Peterson Coil primarily to improve continuity of supply. Since existing protection schemes are designed to detect and indicate the presence of earth faults, it

is reasonable to assume that the embedded generator earth fault protection at the interface should also alarm and indicate the presence of earth faults. It should be noted that the generator would be expected to trip for double line to ground faults and line to line to ground faults.

The loss of mains protection requirement was found to be an issue for most utilities with some utilities opting for Intertripping as a more secure option. At present a number of possible replacement options have been considered which include Active Techniques, GPS Synchronised Phasor Measurement Units (PMUs), Centralised Loss of Mains Protection, Accumulated Phase Angle Difference (PAD) as well as Power Line Signalling Based Techniques. While the aforementioned could each provide a solution to the loss of mains problem, substantial testing of the technology is still required. For the moment, a loosening of the ROCOF protection requirements is proposed for wind farm applications. For the loss of mains protection, it is recommended that the existing settings for ROCOF should be widened to $\pm 2.5\text{Hz}$ (wind farms only). This would help to improve stability of this protection for transient events such as switching etc. However, while widening the ROCOF setting increases stability it also reduces sensitivity. In cases where the difference between load and generation on the islanded system is small, the loss of mains protection operation could be delayed.

The Simulations carried out in PSS/E for both fault and Loss of Mains analysis highlighted the main issues when choosing protection settings. The fault analysis demonstrated that a loosening of the interface protection requirements resulted in improved performance of the wind farm. It was observed that the proposed interface protection settings improved performance by approximately 25%. This would be seen as a significant improvement. However, the loss of mains analysis highlighted the main issues associated with loosening protection settings which is delayed tripping for genuine fault scenarios. It was observed that the proposed settings were anywhere between 200ms – 20 seconds slower in certain cases compared with existing interface protection requirements.

Another point to note is that while the interface protection requirements can be modified to meet voltage, frequency and loss of mains requirements, it is the protection systems inside the wind farm (Turbine/Feeder/Transformer/Statcom Protection) that will ultimately dictate how the wind farm will respond to system events. For example, the voltage protection for the wind turbine could be set to trip

the wind turbine for a +/-10% voltage variation in 100ms while the interface protection is set up for a -20/+10% voltage variation with a trip time of 1.0/0.5seconds. In this case a wind farm could conceivably reduce its output to zero after a fault scenario yet the interface protection has not operated. If the wind farm output is relatively small, the loss of the wind farm would not be significant. However, if the wind farm output is relatively large then the loss of the wind farm could have a significant impact.

6.2 Future Work

The work carried out in this thesis focused primarily on wind farm connections to the 38kV distribution system and the use of DFIG wind turbines at these sites. DFIG's were chosen on the basis that DFIG's are the most popular wind turbine on the Irish system. Future work should include an evaluation of interface protection requirements at the MV and LV distribution level as well as incorporating the effects of other embedded generator devices on the performance of the interface protection.

Furthermore, the data used to evaluate the performance of the DFIG wind turbine was based on typical data obtained from two separate technical sources. While the data gives a good indication on how the wind farm would react to fault/loss of mains scenarios on the system it is not representative of any one manufacturer. In order to evaluate the effects of a specific manufacturers wind turbine, the technical data (Dynamic and Short Circuit Data) would need to be obtained from the manufacturer. However, this data can only be obtained by the TSO and usually comes with a non disclosure agreement and as such can not be accessed publically.

References

- [1]. A. Beddoes, P. Thomas, M. Gosden. "Loss of Mains Protection Relay Performances when Subjected to Network Disturbances/Event", CIRED 18th International Conference on Electricity Distribution, (2005).
- [2]. Adam Dyško, Graeme Burt, Rafał Bugdał, "Novel Protection Methods for Active Distribution Networks with High Penetrations of Distributed Generation", June 2006
- [3]. A.Perdana, "Dynamic Models of Wind Turbines," Ph.D. dissertation, Department of Energy and Environment, Chalmers University of Technology, Göteborg, Sweden, 2009.
- [4]. All Island Generation Capacity Statement 2011 – 2020, EirGrid publication
- [5]. Annual Renewable Report 2010, EirGrid Publication
- [6]. Barkle, J. E.; Ferguson, R. W.; , "Induction Generator Theory and Application," *Power Apparatus and Systems, Part III. Transactions of the American Institute of Electrical Engineers* , vol.73, no.1, pp.12-19, Jan. 1954
- [7]. Boardman, E.; , "The role of integrated distribution management systems in Smart Grid implementations," *Power and Energy Society General Meeting, 2010 IEEE* , vol., no., pp.1-6, 25-29 July 2010
- [8]. C.G. Bright. "COROCOF: Comparison of Rates of Change of Frequency Protection. A Solution to the Detection of Loss of Mains", *IEE 7,, International Conference on Developments in Power System Protection*, pp. 70-73, (200 1).
- [9]. Conditions Governing Connection to the Distribution System, March 2006
- [10]. DIRECTIVE 2009/28/EC OF THE EUROPEAN PARLIAMENT AND OF THE COUNCIL of 23 April 2009 on the promotion of the use of energy from renewable sources and amending and subsequently repealing Directives 2001/77/EC and 2003/30/EC
- [11]. Distribution Code V2.0, October 2007

- [12]. Distribution Standard 931030: Parallel Operation of Private Generators, August 1995
- [13]. EirGrid Monthly Electricity Statistics Update – Jan 2011
- [14]. “Embedded Generation”. N. Jenkins, R. Allan, P. Crossley, D. Kirschen and G. Strbac. IEE Power and Energy Series 31. ISBN 0 85296 774 8
- [15]. “Energy in Ireland Key Statistics 2009”, December 2009. SEI
- [16]. “Engineering Recommendation G 59/1 - Recommendations for the Connection of Embedded Generating Plant to the Public Electricity Suppliers' Distribution Systems”, Energy Networks Association, London 1991.
- [17]. Engineering Recommendation G75
- [18]. “Ensuring a Secure, Reliable and Efficient Power System in a Changing Environment”, June 2011, EirGrid Publication
- [19]. G.Kabashi, K.Kadriu, A.Gashi, S.Kabashi, G.Pula, V.Komoni, “Wind Farm Modeling for Steady State Dynamic Analysis”, 2011
- [20]. “Global Wind Report – Annual Market Update 2010”, March 2011
- [21]. Government White Paper “Delivering A Sustainable Energy Future For Ireland”, 2007
- [22]. Grid 25 – A Strategy for the development of Ireland’s Electricity Grid for a Sustainable and Competitive Future, EirGrid Publication
- [23]. “Grid Integration of Wind Generation”, February 2011. CIGRE working group C6.08
- [24]. “Kraftvaerksspecifikationer for produktionsanlaeg < 2MW” (Eltra)
- [25]. Krisztina Leban, “Doubly Fed Induction Generator Fault Simulation” Institute of Energy Technology Aalborg 2009
- [26]. M. Seyedi, “Evaluation of the DFIG Wind Turbine Built-in Model in PSSE”, June 2009
- [27]. Nicholas W.Miller, “Dynamic Modeling of GE 1.5 and 3.6 Wind Turbine-Generators,” Version 4.1 Jan.2008.
- [28]. N.Rahmat Ullah, “Wind Power –Added Value for Network Operation,” Ph.D. dissertation, Department of Energy and Environment, Chalmers University of Technology, Göteborg, Sweden, 2008.

- [29]. PSSE Model Library, June 2009
- [30]. R. Bugdal, A. Dysko, G.M. Burt, J.R. McDonald. "Performance Analysis of the ROCOF and Vector Shift Methods Using a Dynamic Protection Modelling Approach", 15th International Conference on Power System Protection, pp. 139-144, (2006).
- [31]. Renewable Energy in Ireland 2010 Update, Sustainable Energy Authority Ireland
- [32]. Siemens 7RW600 V3.0 Instruction Manual, Siemens AG 1997; 2001
- [33]. S. Muller, M. Deicke and R. W. de Doncker. "Doubly Fed Induction Generator Systems for Wind Turbines". IEEE Industry Applications Magazine. May/June 2002.
- [34]. "Standardvilkår for nettilslutning af locale kraftvarmeanlæg" (Energi E2)
- [35]. "Technical Regulations for Thermal Power Station Units of 1.5 MW and higher - Regulation for grid connection TF 3.2.3", September 2007, Energinet Publication
- [36]. Ten, C.F.; Crossley, P.A.; , "Evaluation of Rocof Relay Performances on Networks with Distributed Generation," *Developments in Power System Protection, 2008. DPSP 2008. IET 9th International Conference on* , vol., no., pp.523-528, 17-20 March 2008
- [37]. "The Impact of Renewable Energy Sources and Distributed Generation on Substation Protection and Automation", August 2010. CIGRE working group B5.34
- [38]. Thomas Ackermann," Wind Power in Power Systems," Royal Institute of Technology, Stockholm, Sweden
- [39]. Transmission Forecast Statement 2011 – 2017, EirGrid Publication
- [40]. "World Wind Energy Report 2010", April 2011
- [41]. X. Ding. "Synchronized Phasor Measurement and Islanding Operation of Distributed Generation ", Faculty of Engineering and Power System, the Queen's University, Belfast, (2006).
- [42]. <http://www.eirgrid.com/operations/systemperformancedata/systemrecords/>
- [43]. <http://www.eirgrid.com/operations/systemperformancedata/>

- [44]. <http://www.eirgrid.com/aboutus/publications/transmissionforecaststatement2010-2016/forecaststatement2010-2016modelfiles/>
- [45]. http://www.ssb.no/elektrisitetaar_en/tab-2011-04-13-03-en.html

Appendix

A PSS/E Wind Turbine Model Documentation

Wind Generator Model Data Sheet [29]

17.3 WT3G1

Doubly-Fed Induction Generator (Type 3)

This model is located at system bus #_____ IBUS,
 Machine identifier #_____ ID,
 This model uses CONs starting with #_____ J,
 and STATEs starting with #_____ K,
 and VARs starting with #_____ L,
 and ICON #_____ M.

CONs	#	Value	Description
J			X_{eq} , Equivalent reactance for current injection (pu)
J+1			K_{pll} , PLL first integrator gain
J+2			K_{ipll} , PLL second integrator gain
J+3			P_{llmax} , PLL maximum limit
J+4			Prated, Turbine MW rating

STATEs	#	Description
K		Converter lag for Ipcmd
K+1		Converter lag for Eqcmd
K+2		PLL first integrator
K+3		PLL second integrator

VARs	#	Description
L		V_x , Real component of V_{term} in generator ref. frame
L+1		V_y , Imaginary component of V_{term} in generator ref. frame
L+2		I_{xinj} , Active component of the injected current
L+3		I_{yinj} , Reactive component of the injected current

ICON	#	Description
M		Number of lumped wind turbines

IBUS, 'WT3G1', ID, ICON(M), CON(J) to CON(J+4) /

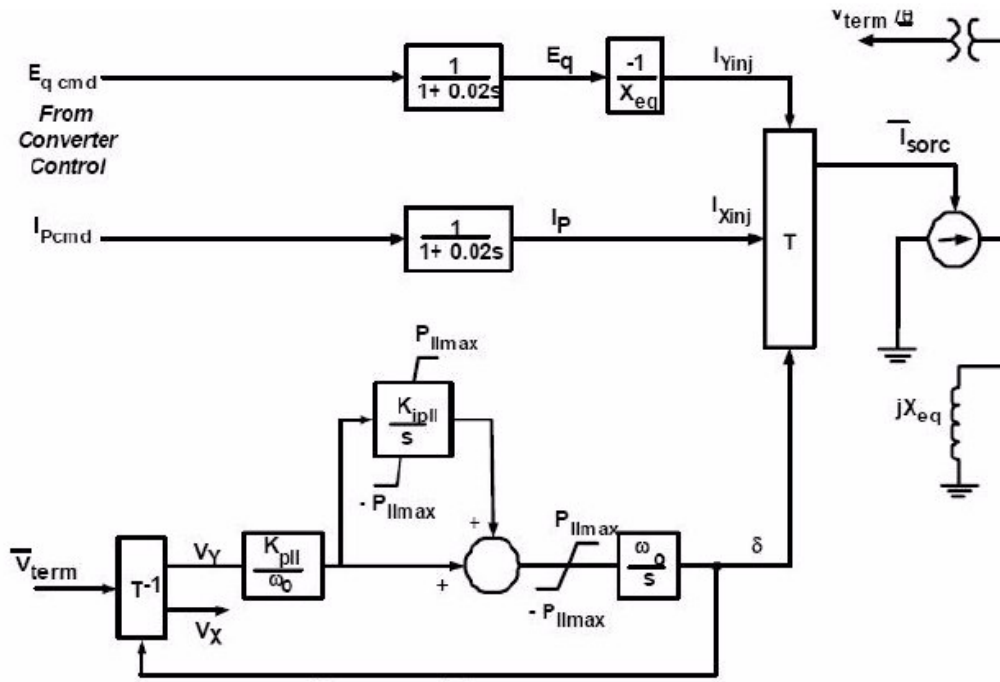

- Notes:
1. \bar{V}_{term} and \bar{I}_{sorc} are complex values on network reference frame.
 2. In steady-state, $V_Y = 0$, $V_X = V_{term}$, and $\delta = \theta$.
 3. $X_{eq} = \text{Imaginary (ZSORCE)}$

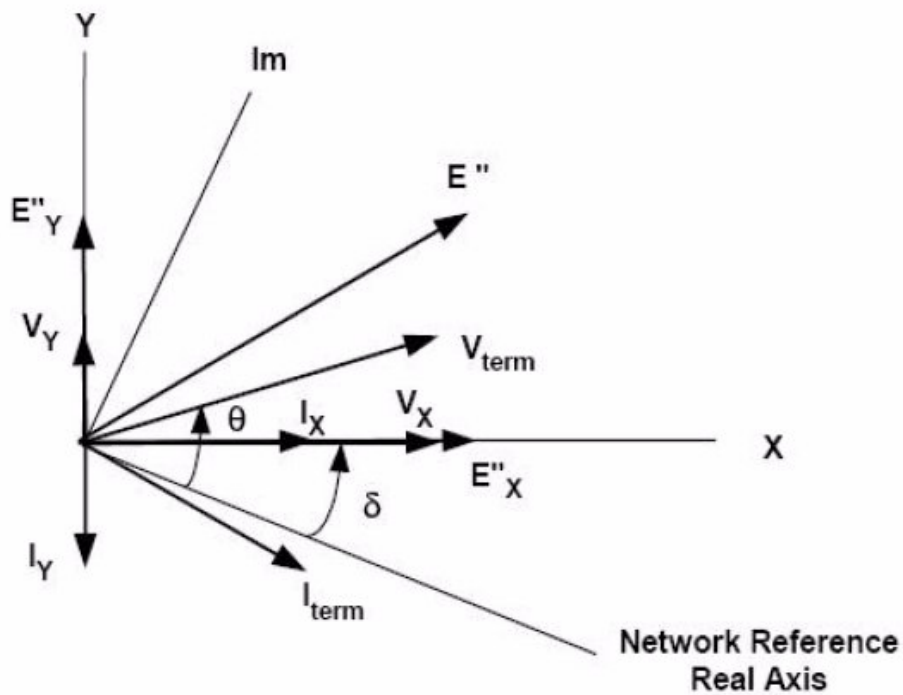

Wind Electrical Model Data Sheet [29]

18.2 WT3E1

Electrical Control for Type 3 Wind Generator (for WT3G1 and WT3G2)

This model is located at system bus # _____ IBUS
 Machine identifier # _____ ID
 This model uses CONs starting with # _____ J
 and STATEs starting with # _____ K
 and VARs starting with # _____ L
 and ICONs starting with # _____ M

CONs	#	Value	Description
J			T_{fv} , Filter time constant in voltage regulator (sec)
J+1			K_{pv} , Proportional gain in voltage regulator (pu)
J+2			K_{iv} , Integrator gain in voltage regulator (pu)
J+3			X_c , Line drop compensation reactance (pu)
J+4			T_{FP} , Filter time constant in torque regulator
J+5			K_{pp} , Proportional gain in torque regulator (pu)
J+6			K_{ip} , Integrator gain in torque regulator (pu)
J+7			P_{MX} , Max limit in torque regulator (pu)
J+8			P_{MN} , Min limit in torque regulator (pu)
J+9			Q_{MX} , Max limit in voltage regulator (pu)
J+10			Q_{MN} , Min limit in voltage regulator (pu)
J+11			IP_{MAX} , Max reactive current limit
J+12			T_{RV} , Voltage sensor time constant
J+13			RP_{MX} , Max power order derivative
J+14			RP_{MN} , Min power order derivative
J+15			T_{Power} , Power filter time constant
J+16			K_{qi} , MVAR/Voltage gain
J+17			V_{MINCL} , Min voltage limit
J+18			V_{MAXCL} , Max voltage limit
J+19			K_{qv} , Voltage/MVAR gain
J+20			XIQ_{min}
J+21			XIQ_{max}
J+22			T_v , Lag time constant in WindVar controller
J+23			T_p , P_{elec} filter in fast PF controller

CONs	#	Value	Description
J+24			F_n , A portion of online wind turbines
J+25			$\omega_{P_{min}}$, Shaft speed at P_{min} (pu)
J+26			$\omega_{P_{20}}$, Shaft speed at 20% rated power (pu)
J+27			$\omega_{P_{40}}$, Shaft speed at 40% rated power (pu)
J+28			$\omega_{P_{60}}$, Shaft speed at 60% rated power (pu)
J+29			P_{min} , Minimum power for operating at $\omega_{P_{100}}$ speed (pu)
J+30			$\omega_{P_{100}}$, Shaft speed at 100% rated power (pu)

STATES	#	Description
K		Filter in voltage regulator
K+1		Integrator in voltage regulator
K+2		Filter in torque regulator
K+3		Integrator in torque regulator
K+4		Voltage sensor
K+5		Power filter
K+6		MVAR/Vref integrator
K+7		Verror/internal machine voltage integrator
K+8		Lag of the WindVar controller
K+9		Input filter of P_{elec} for PF fast controller

VARs	#	Description
L		Remote bus ref voltage
L+1		MVAR order from MVAR emulator
L+2		Q reference if PFAFLG=0 & VARFLG=0
L+3		PF angle reference if PFAFLG=1
L+4		Storage of MW for computation of compensated voltage
L+5		Storage of MVAR for computation of compensated voltage
L+6		Storage of MVA for computation of compensated voltage

ICONS	#	Description
M		Remote bus # for voltage control; 0 for local voltage control
M+1		VARFLG: 0 Constant Q control 1 Use Wind Plant reactive power control -1 Constant power factor control
M+2 ¹		VLTF LG: 0 Bypass terminal voltage control 1 Eqcmd limits are calculated as VTerm + XIQmin and VTerm + XIQmax, i.e., limits are functions of terminal voltage 2 Eqcmd limits are equal to XIQmin and XIQ max
M+3		From bus of the interconnection transformer
M+4		To bus of the interconnection transformer
M+5		Interconnection transformer ID

¹ WT3E1 model can be used with WT3G1 as well as WT3G2 models. When used with WT3G1 model, it is recommended that ICON(M+2) be set to 1; and when used with WT3G2 model, the ICON(M+2) be set to 2.

IBUS, 'WT3E1', ID, ICON(M) to ICON(M+5), CON(J) to CON(J+30) /

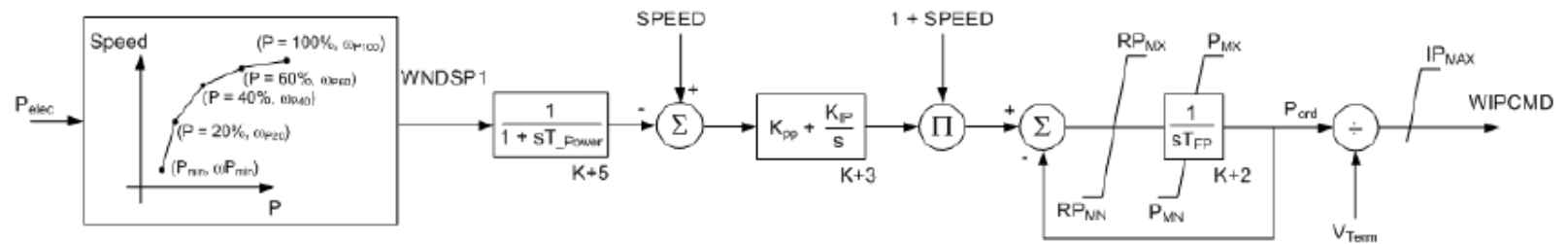
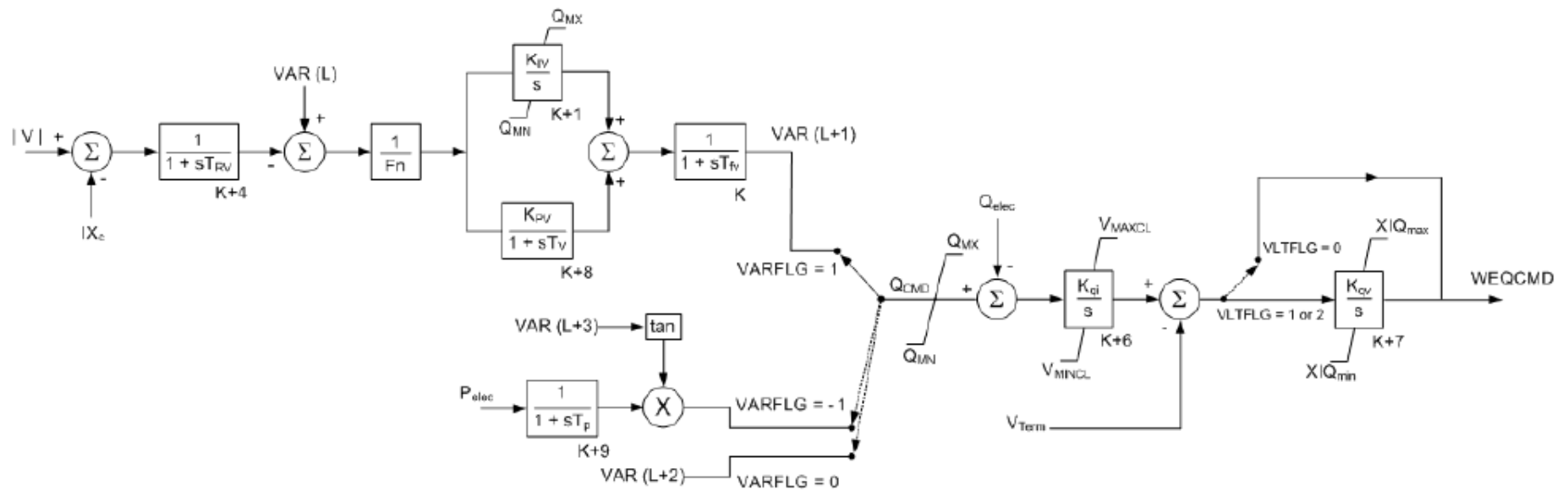

Wind Mechanical Model Data Sheet [29]

19.2 WT3T1

Mechanical System Model for Type 3 Wind Generator (for WT3G1 and WT3G2)

This model is located at system bus #_____ IBUS,
 Machine identifier #_____ ID,
 This model uses CONs starting with #_____ J,
 and STATEs starting with #_____ K,
 and VARs starting with #_____ L.

In blkmdl, this model requires one reserved ICON.

CONs	#	Value	Description
J			VW, Initial wind, pu of rated wind speed
J+1			H, Total inertia constant, sec
J+2			DAMP, Machine damping factor, pu P/pu speed
J+3			K _{aero} , Aerodynamic gain factor
J+4			Theta2, Blade pitch at twice rated wind speed, deg.
J+5			H _{frac} , Turbine inertia fraction (H _{turb} /H) ¹
J+6			Freq1, First shaft torsional resonant frequency, Hz
J+7			D _{shaft} , Shaft damping factor (pu)

¹ To simulate one-mass mechanical system, set H_{frac} = 0.
 To simulate two-mass mechanical system, set H_{frac} as 0 < H_{frac} < 1.

STATEs	#	Description
K		Shaft twist angle, rad.
K+1		Turbine rotor speed deviation, pu
K+2		Generator speed deviation, pu
K+3		Generator rotor angle deviation, pu

VARs	#	Description
L		P _{aero} on the rotor blade side, pu
L+1		Initial rotor slip
L+2		Initial internal angle
L+3		Initial pitch angle
L+4		P _{aero} initial

IBUS, 'WT3T1', ID, CON(J) to CON (J+7) /

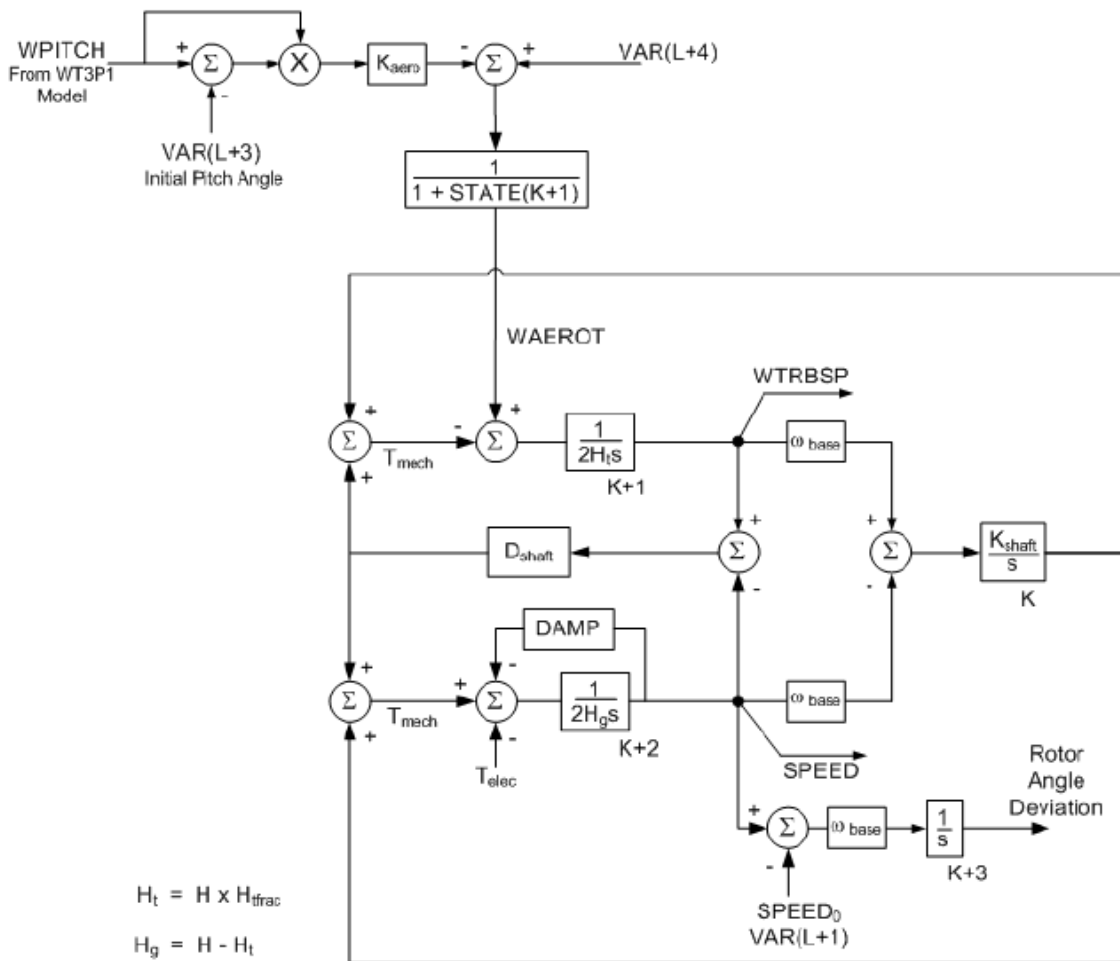

$H_t = H \times H_{frac}$
 $H_g = H - H_t$

$$K_{shaft} = \frac{2H_t \times H_g \times (2\pi \times Freq1)^2}{H \times \omega_0}$$

Wind Pitch Control Model Data Sheet [29]

20.1 WT3P1

Pitch Control Model for Type 3 Wind Generator (for WT3G1 and WT3G2)

This model is located at system bus # _____ IBUS,
 Machine identifier # _____ ID,
 This model uses CONs starting with # _____ J,
 and STATES starting with # _____ K.

In blkmdl, this model requires one reserved ICON.

CONs	#	Value	Description
J			T_p , Blade response time constant
J+1			K_{pp} , Proportional gain of PI regulator (pu)
J+2			K_{ip} , Integrator gain of PI regulator (pu)
J+3			K_{pc} , Proportional gain of the compensator (pu)
J+4			K_{ic} , Integrator gain of the compensator (pu)
J+5			TetaMin, Lower pitch angle limit (degrees)
J+6			TetaMax, Upper pitch angle limit (degrees)
J+7			RTetaMax, Upper pitch angle rate limit (degrees/sec)
J+8			P_{MX} , Power reference, pu on MBASE

Note: When a WT operates with a partial output, the DSTATE(K+2) may show INITIAL CONDITION SUSPECT. In this case no actions are needed.

STATES	#	Description
K		Output lag
K+1		Pitch control
K+2		Pitch compensation

IBUS, 'WT3P1', ID, CON(J) to CON (J+8) /

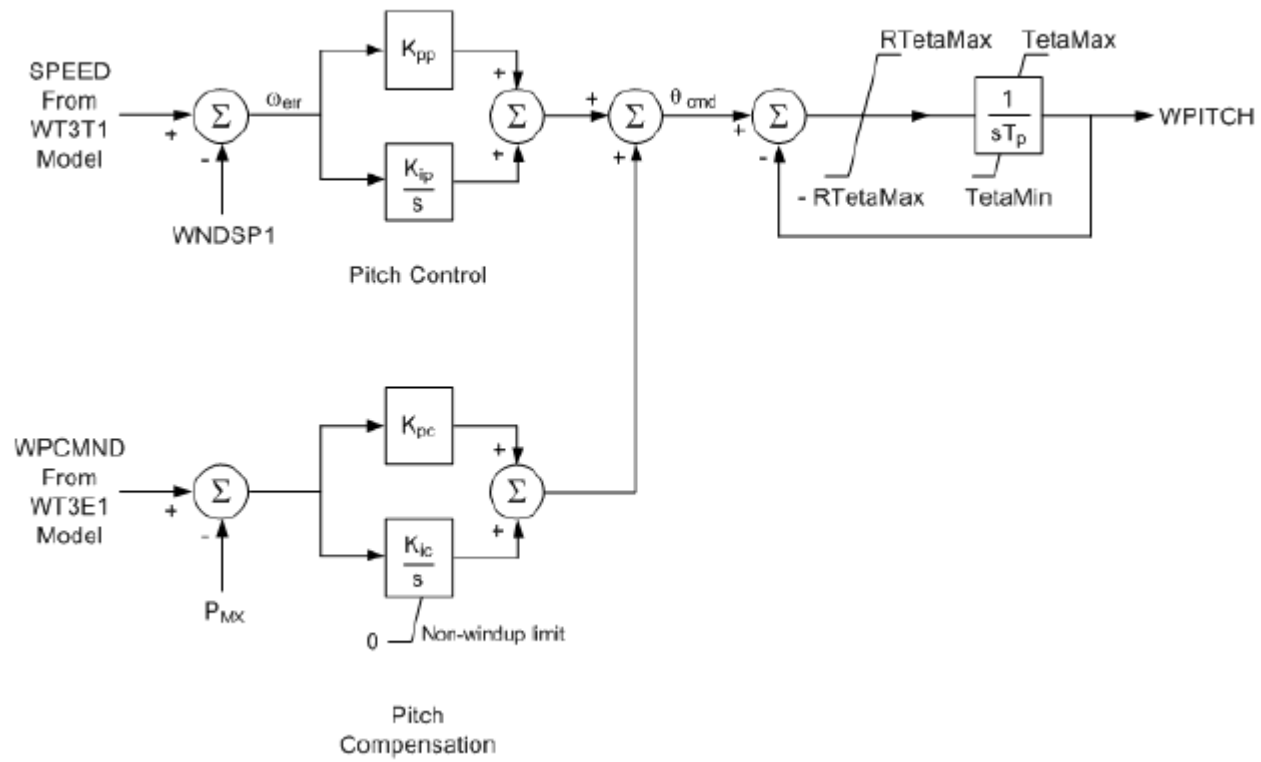

B PSS/E Generator Turbine Model Documentation

Generator Model Data [29]

Round Rotor Generator Model (Quadratic Saturation)

This model is located at system bus # _____ IBUS,

Machine identifier # _____ ID,

This model uses CONs starting with # _____ J,

and STATEs starting with # _____ K.

The machine MVA is _____ for each of _____ units = _____ MBASE.

ZSORCE for this machine is _____ + j _____ on the above MBASE

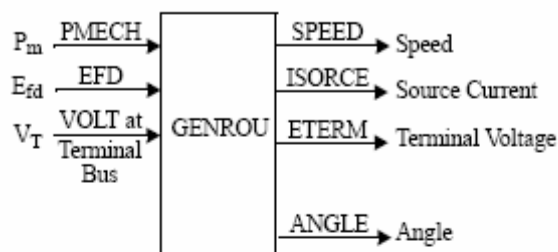

CONs	#	Value	Description
J			T'_{do} (>0) (sec)
J+1			T''_{do} (>0) (sec)
J+2			T'_{qo} (>0) (sec)
J+3			T''_{qo} (>0) (sec)
J+4			H, Inertia
J+5			D, Speed damping
J+6			X_d
J+7			X_q
J+8			X'_d
J+9			X'_q
J+10			$X''_d = X''_q$
J+11			X_l
J+12			S(1.0)
J+13			S(1.2)

Note: X_d , X_q , X'_d , X'_q , X''_d , X''_q , X_l , H, and D are in pu, machine MVA base.

X''_q must be equal to X''_d .

STATEs	#	Description
K		E'_q
K+1		E'_d
K+2		ψ_{kd}
K+3		ψ_{kq}
K+4		Δ speed (pu)
K+5		Angle (radians)

IBUS, 'GENROU', ID, CON(J) to CON(J+13) /

Excitation System Model Data [29]

Bus Fed or Solid Fed Static Exciter

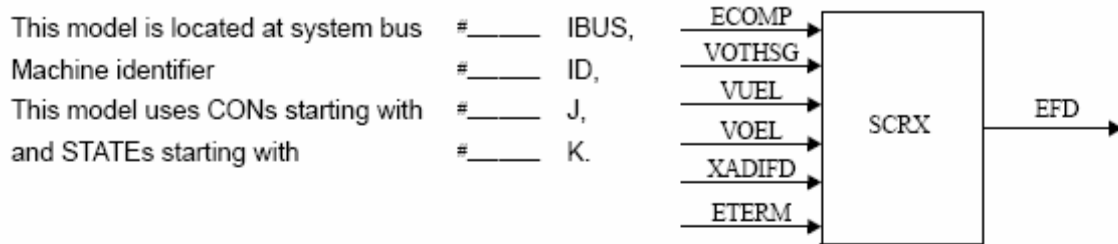

CONs	#	Value	Description
J			T_A/T_B
J+1			$T_B (>0)$ (sec)
J+2			K
J+3			T_E (sec)
J+4			E_{MIN} (pu on EFD base)
J+5			E_{MAX} (pu on EFD base)
J+6			C_{SWITCH} ¹
J+7			r_c / r_{fd}^2

¹ Set $C_{SWITCH} = 0$ for bus fed.

Set $C_{SWITCH} = 1$ for solid fed.

² Set $CON(J+7) = 0$ for exciter with negative field current capability.

Set $CON(J+7) > 0$ for exciter without negative field current capability.

(Typical $CON(J+7) = 10$)

STATEs	#	Description
K		First integrator
K+1		Second integrator

IBUS, 'SCRX', ID, CON(J) to CON(J+7) /

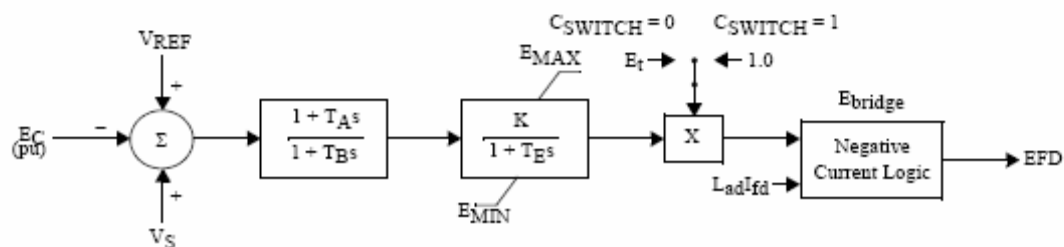

$$V_S = VOTHSG + VUEL + VOEL$$

Turbine Governor Model Data [29]

Steam Turbine-Governor

This model is located at system bus # _____ IBUS,
 Machine identifier # _____ ID,
 This model uses CONs starting with # _____ J,
 and STATEs starting with # _____ K,
 and VAR # _____ L.



CONs	#	Value	Description
J			R
J+1			$T_1 (>0)$ (sec)
J+2			V_{MAX}^1
J+3			V_{MIN}^1
J+4			T_2 (sec) ²
J+5			$T_3 (>0)$ (sec) ³
J+6			D_t^1

¹ V_{MAX} , V_{MIN} , D_t are in per unit on generator base.

² T_2/T_3 = high-pressure fraction.

³ T_3 = reheater time constant.

STATEs	#	Description
K		Valve opening
K+1		Turbine power

VARs	#	Description
L		Reference

IBUS, 'TGOV1', ID, CON(J) to CON(J+6) /

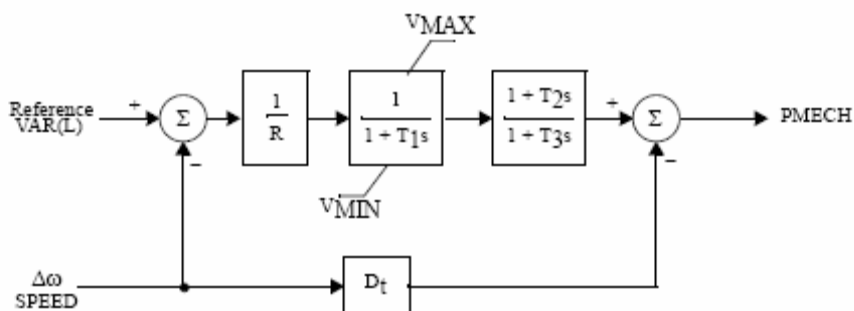

C *Single Line Diagrams*

38kV Distribution System Test Model - Summer Valley

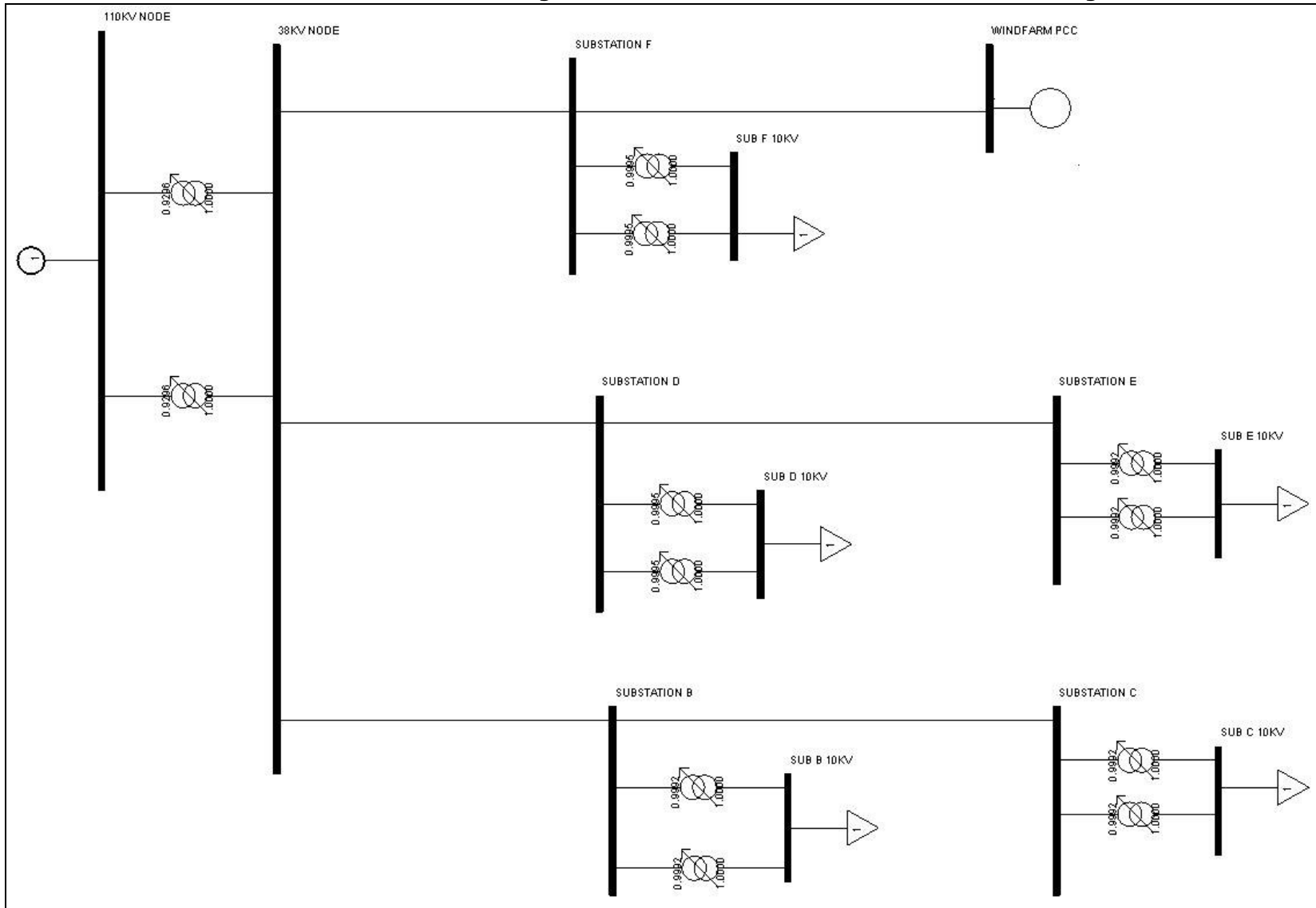

38kV Distribution System Test Model – Winter Peak

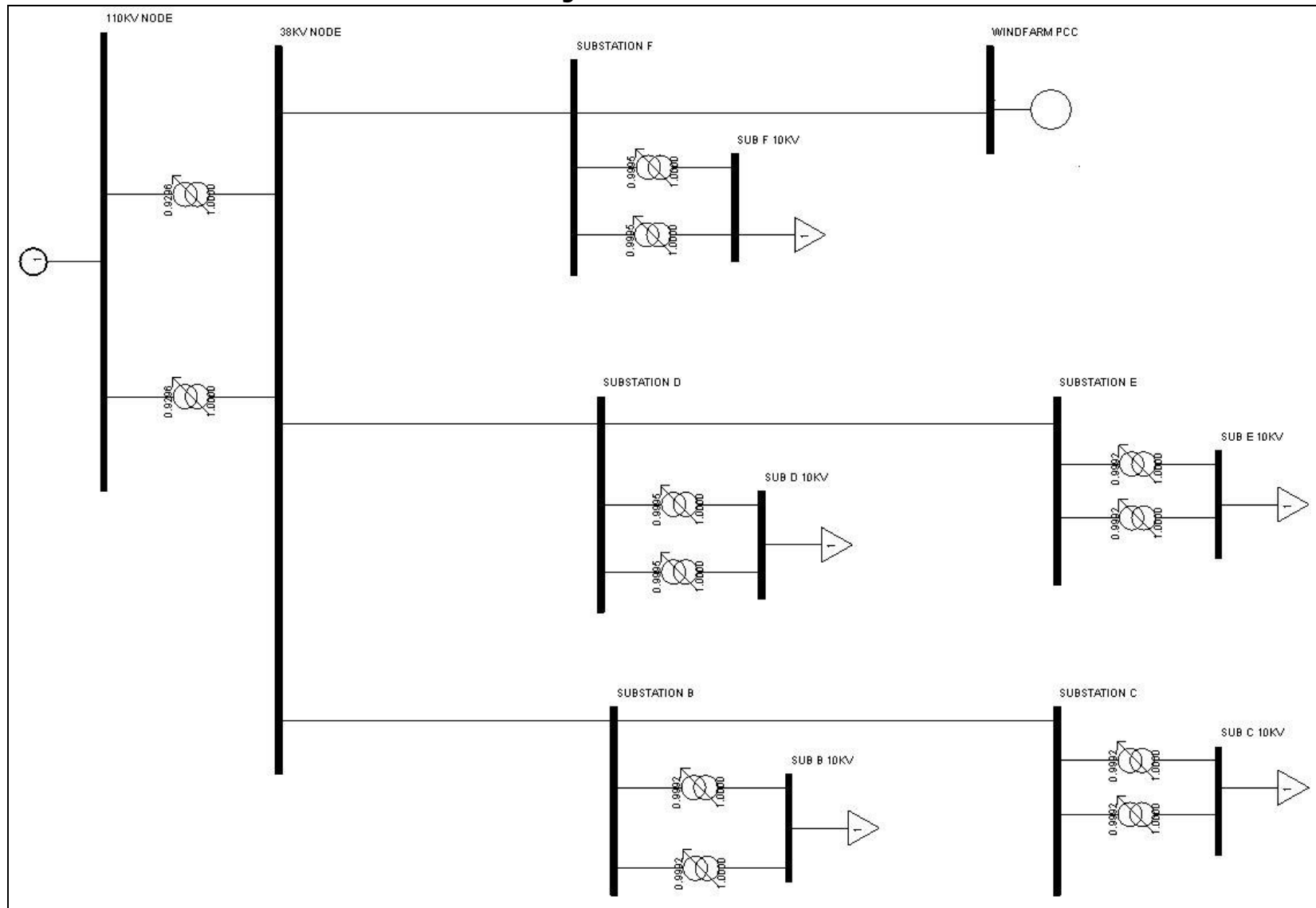

Wind farm Single Line Diagram

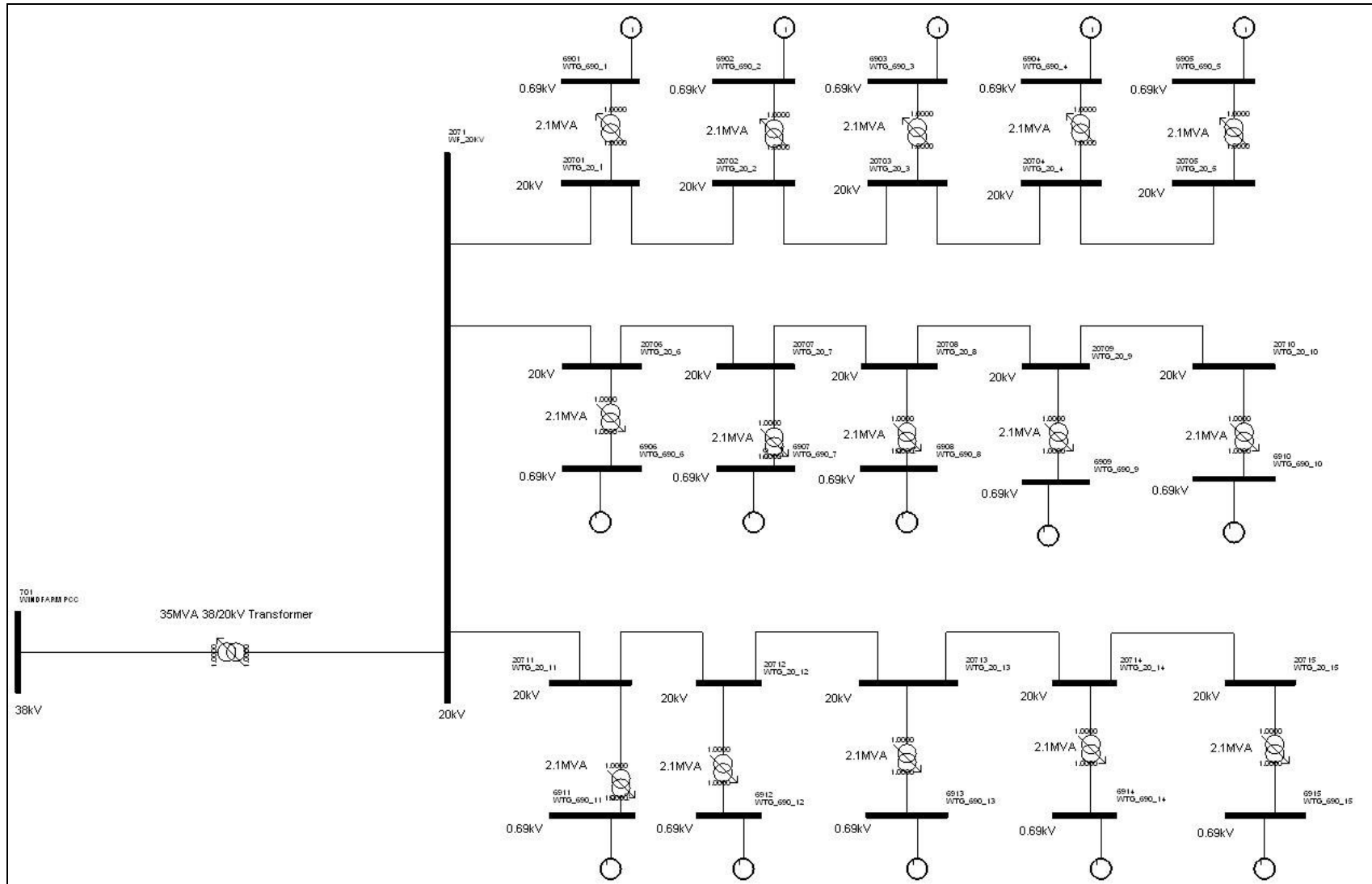

D Wind Farm Technical Data

Wind Turbine Power Flow Data

Symbol	Value	Unit
Sn	2.00	MVA
Qmax	0.65	MVAr
Qmin	-0.65	MVAr
Pmax	2.00	MW
Pmin	0.10	MW
Zsource	0 + j0.8	p.u
Mbase	2.1	MVA

Table D.1: Wind Turbine Generator Data [19]

Wind Turbine Step up Transformer Data

Symbol	Value	Unit
Sn	2.10	MVA
HV	20.00	KV
LV	0.69	KV
Ztrafo	0.0073 + j0.06	p.u
Mbase	2.10	MVA

Table D.2: Wind Turbine Transformer Data [19]

Wind Turbine Dynamic Data

Symbol	Value	Unit
Xeq	0.8	p.u
Pll gain	30	con
Pll integrator gain	0	con
Pll maximum	0.1	cons
Turbine MW rating	2	MW
Nr. of lumped WT-s	1	Integer

Table D.3: Generator Model WT3G1 [19]

Symbol	Value	Unit
Vw	1.2	p.u
H	4.95	MW*sec/MVA
DAMP	0	p.u P/pu
Kaero	0.007	const.
Theta2	21.98	deg.
Htfac	0.875	Hturb/H
Freq1	1.8	Hz
DSHAFT	1.5	p.u P/pu

Table D.4: Turbine Model WT3T1 [19]

Symbol	Value	Unit
Tfv	0.15	sec
Kpv	18	p.u
Kiv	5	p.u
Xc	0	p.u
Tfp	0.05	sec
Kpp	3	p.u
Kip	0.6	p.u
PMX	1.12	p.u
PMN	0.1	p.u
QMX	0.309	p.u
QMN	-0.309	p.u
IPMAX	1.1	p.u
TRV	0.05	sec
RPMX	0.45	p.u
RPMN	-0.45	p.u
T_Power	5	sec
KQi	0.05	con
VMINCL	0.9	con
VMAXCL	1.2	con
Kqv	40	Con
XIQmin	-0.5	con
XIQmax	0.4	con
Tv	0.05	sec
Fn	1	con
Wpmin	0.69	p.u
Wp20	0.78	p.u
Wp40	0.98	p.u
Wp60	1.12	p.u
Pwp	0.74	p.u
Wp100	1.2	p.u

Table D.5: Electrical Model WT3E1 [19]

Symbol	Value	Unit
Tp	0.3	sec
Kpp	150	pu
Kip	25	pu
Kpc	3	pu
Kic	30	pu
TetaMin	0	deg
TetaMax	27	deg
RTetaMax	10	deg/sec
PMX	1	p.u on Mbase

Table D.6: Pitch Model WT3P1 [19]

Wind Farm Internal Cable Data – Positive Sequence Data

Feeder	Length (Km)	Conductor Type	R (p.u)	X (p.u)	B (p.u)	MVA Rating
20kV Collector - WTG 1	0.5	150mm AAAC	0.02906	0.04741	0.0000061	12.2
WTG 1 - WTG2	0.5	150mm AAAC	0.02906	0.04741	0.0000061	12.2
WTG 2 - WTG3	0.5	150mm AAAC	0.02906	0.04741	0.0000061	12.2
WTG 3 - WTG4	0.5	50mm Cu	0.04909	0.04979	0.0000058	6.10
WTG 4 - WTG5	0.5	50mm Cu	0.04909	0.04979	0.0000058	6.10
20kV Collector - WTG 6	0.5	150mm AAAC	0.02906	0.04741	0.0000061	12.2
WTG 6 - WTG7	0.5	150mm AAAC	0.02906	0.04741	0.0000061	12.2
WTG 7- WTG8	0.5	150mm AAAC	0.02906	0.04741	0.0000061	12.2
WTG 8 - WTG9	0.5	50mm Cu	0.04909	0.04979	0.0000058	6.10
WTG 9 - WTG10	0.5	50mm Cu	0.04909	0.04979	0.0000058	6.10
20kV Collector - WTG 11	0.5	150mm AAAC	0.02906	0.04741	0.0000061	12.2
WTG 11 - WTG12	0.5	150mm AAAC	0.02906	0.04741	0.0000061	12.2
WTG 12 - WTG13	0.5	150mm AAAC	0.02906	0.04741	0.0000061	12.2
WTG 13 - WTG14	0.5	50mm Cu	0.04909	0.04979	0.0000058	6.10
WTG 14 - WTG15	0.5	50mm Cu	0.04909	0.04979	0.0000058	6.10

Table D.7: Wind farm Internal Cable Data (Positive Sequence Data)

Wind Farm Internal Cable Data – Zero Sequence Data

Feeder	Length (Km)	Conductor Type	R (p.u)	X (p.u)	B (p.u)	MVA Rating
20kV Collector - WTG 1	0.5	150mm AAAC	0.04747	0.21395	0.0000032	12.2
WTG 1 - WTG2	0.5	150mm AAAC	0.04747	0.21395	0.0000032	12.2
WTG 2 - WTG3	0.5	150mm AAAC	0.04747	0.21395	0.0000032	12.2
WTG 3 - WTG4	0.5	50mm Cu	0.06759	0.22248	0.0000029	6.10
WTG 4 - WTG5	0.5	50mm Cu	0.06759	0.22248	0.0000029	6.10
20kV Collector - WTG 6	0.5	150mm AAAC	0.04747	0.21395	0.0000032	12.2
WTG 6 - WTG7	0.5	150mm AAAC	0.04747	0.21395	0.0000032	12.2
WTG 7- WTG8	0.5	150mm AAAC	0.04747	0.21395	0.0000032	12.2
WTG 8 - WTG9	0.5	50mm Cu	0.06759	0.22248	0.0000029	6.10
WTG 9 - WTG10	0.5	50mm Cu	0.06759	0.22248	0.0000029	6.10
20kV Collector - WTG 11	0.5	150mm AAAC	0.04747	0.21395	0.0000032	12.2
WTG 11 - WTG12	0.5	150mm AAAC	0.04747	0.21395	0.0000032	12.2
WTG 12 - WTG13	0.5	150mm AAAC	0.04747	0.21395	0.0000032	12.2
WTG 13 - WTG14	0.5	50mm Cu	0.06759	0.22248	0.0000029	6.10
WTG 14 - WTG15	0.5	50mm Cu	0.06759	0.22248	0.0000029	6.10

Table D.8: Wind farm Internal Cable Data (Zero Sequence Data)

Wind Farm Grid Transformer

Symbol	Value	Unit
Sn	35	MVA
HV	38	KV
LV	20	KV
Ztrafo (Positive Sequence)	0.00486 + j0.108892	p.u
Ztrafo (Zero Sequence)	0.00437 + j0.098600	p.u
Mbase	35	MVA
No. of Taps		
Max Tap		KV
Min Tap		KV

Table D.9: Wind Farm Grid Transformer

Statcom

Symbol	Value	Unit
Voltage	20	KV
Reactive Power Range	+ 10/-5	MVARs
Step Size	1	MVAR

Table D.10: Statcom

E 38kV Distribution System Technical Data

38kV Distribution System Feeder Data – Positive Sequence Data

Feeder	Voltage (kV)	Length (Km)	R (p.u)	X (p.u)	B (p.u)
38kV Node - Substation B	38	8.9	0.229	0.234	0.00106
Substation B - Substation C	38	10.7	0.285	0.297	0.00046
38kV Node - Substation D	38	14.3	0.376	0.392	0.00086
Substation D - Substation E	38	13.9	0.085	0.117	0.01420
38kV Node - Substation F	38	20.8	0.274	0.587	0.00154
Substation F - Wind farm 38kV	38	16.0	0.395	0.426	0.00156
PCC					

Table E.1: 38kV Distribution System Feeder Data (Positive Sequence Data)

38kV Distribution System Feeder Data – Zero Sequence Data

Feeder	Voltage (kV)	Length (Km)	R (p.u)	X (p.u)	B (p.u)
38kV Node - Substation B	38	8.9	0.319	1.041	0.00088
Substation B - Substation C	38	10.7	0.395	1.283	0.00024
38kV Node - Substation D	38	14.3	0.522	1.695	0.00058
Substation D - Substation E	38	13.9	0.176	0.097	0.01420
38kV Node - Substation F	38	20.8	0.486	2.245	0.00122
Substation F - Wind farm 38kV	38	16.0	0.556	1.838	0.00126
PCC					

Table E.2: 38kV Distribution System Feeder Data (Zero Sequence Data)

5MVA 38/10kV Transformer Data

Symbol	Value	Unit
Sn	5	MVA
HV	38	KV
LV	10	KV
Ztrafo	7.56	%
Mbase	5	MVA
No. of Taps	15	
Max Tap	41.251	KV
Min Tap	34.686	KV

Table E.3: 5MVA 38/10kV Transformer Data

10MVA 38/10kV Transformer Data

Symbol	Value	Unit
Sn	10	MVA
HV	38	KV
LV	10	KV
Ztrafo	9.61	%
Mbase	10	MVA
No. of Taps	15	
Max Tap	41.250	KV
Min Tap	34.710	KV

Table E.4: 10MVA 38/10kV Transformer Data

63MVA 110/38kV Transformer Data

Symbol	Value	Unit
Sn	63	MVA
HV	110	KV
LV	38	KV
Ztrafo	0.0105 + j0.3380	p.u
Mbase	100	MVA
No. of Taps	13	
Max Tap	122.50	KV
Min Tap	92.50	KV

Table E.5: 63MVA 110/38kV Transformer Data

System Thevenin Impedance – Summer Valley 2010 [44]

```

PSS@E IEC 60909 SHORT CIRCUIT CURRENTS          FRI, JUL 29 2011 17:21
/ CASE: 2010;  SUMMER 01/07/2010; FORECAST STATEMENT 2010 - ** +VE SEQ LINE CHARGING 0.0 **
/ FS10_NOV 09 - MEMO GALLERY_T; 09:56:59 THURSDAY, DECEMB ** +VE SEQ LOAD, FIXED SHUNT, SWITCHED SHUNT 0.0 **
VOLTAGE FACTOR C=1.10,  NOMINAL FREQUENCY=50.0 Hz,  BREAKING CURRENT at TIME= 0.100 seconds
<-SCMVA-><-SymI''krms--><-ip(B)-><-ip(C)-><-DC Ib-><SymIb-><AsymIb>
          /I/      AN(I)      /I/      /I/      /I/      /I/
X----- BUS -----X          MVA      AMP      DEG      AMP      AMPAMPAMPAMP
5281 [TRALEE      110.00] 3PH    1133.48  5949.2  -76.83  14569.3  12712.4    73.4    5940.1    5940.6
          LG      1032.41  5418.7  -79.05  13823.2  12044.7    140.5    5418.7    5420.6
Note - ip(B) currents include safety factor multiplier (1.15).
THEVENIN IMPEDANCE, X/R (OHM)      Z+:2.675+j11.434, 4.27492  Z-:2.073+j8.856, 4.27256  Z0:2.597+j17.682, 6.80765

```

System Thevenin Impedance – Winter Peak 2010 [44]

```

PSS@E IEC 60909 SHORT CIRCUIT CURRENTS          FRI, JUL 29 2011 17:28
/ CASE: 2010/2011;  WINTER 01/12/2010; FORECAST STATEMENT 20 ** +VE SEQ LINE CHARGING 0.0 **
/ FS10_NOV 09 - MEMO GALLERY_T; 16:24:29 MONDAY, NOVEMBER ** +VE SEQ LOAD, FIXED SHUNT, SWITCHED SHUNT 0.0 **
VOLTAGE FACTOR C=1.10,  NOMINAL FREQUENCY=50.0 Hz,  BREAKING CURRENT at TIME= 0.100 seconds
<-SCMVA-><-SymI''krms--><-ip(B)-><-ip(C)-><-DC Ib-><SymIb-><AsymIb>
          /I/      AN(I)      /I/      /I/      /I/      /I/
X----- BUS -----X          MVA      AMP      DEG      AMP      AMPAMPAMPAMP
5281 [TRALEE      110.00] 3PH    1668.72  8758.5  -78.37  22057.0  19310.4    236.4    8726.9    8730.1
          LG      1348.74  7079.1  -80.22  18469.9  16122.5    257.8    7079.1    7083.7
Note - ip(B) currents include safety factor multiplier (1.15).
THEVENIN IMPEDANCE, X/R (OHM)      Z+:1.608+j7.812, 4.85778  Z-:1.382+j6.655, 4.81456  Z0:2.039+j14.708, 7.21217

```

38KV System Loading – Summer Valley

Substation	Active Power (MW)	Reactive Power (MVARs)
B	3.14	1.03
C	2.67	0.88
D	6.81	2.24
E	3.84	1.26
F	6.40	2.10

Table E.6: System Loading – Sumer Valley

38KV System Loading – Winter Peak

Substation	Active Power (MW)	Reactive Power (MVARs)
B	6.28	2.06
C	5.34	1.76
D	13.61	4.47
E	7.67	2.52
F	12.79	4.20

Table E.7: System Loading – Winter Peak

System Equivalent Generator Model Data

Symbol	Value	Unit
T'do (> 0)	6.4	
T''do (> 0)	0.045	
T'qo (> 0)	0.54	
T''qo (> 0)	0.085	
Inertia H	5.545	
Speed Damping D	0	
Xd	2.06	
Xq	1.97	
X'd	0.305	
X'q	0.51	
X''d = X''q	0.0945	
Xl	0.175	
S(1.0)	0.0497	
S(1.2)	0.3978	

Table E.8: System Equivalent Generator Model

System Equivalent Excitation Model Data

Symbol	Value	Unit
TA/TB	0.1	
TB (> 0)	10	
K	100	
TE	0.1	
EMIN	-0.88	
EMAX	5	
CSWITCH (0=bus fed, 1=solid fed)	0	
rc/rfd	0	
TA/TB	0.1	
TB (> 0)	10	
K	100	

Table E.9: System Equivalent Excitation Model

System Equivalent Governor Model Data

Symbol	Value	Unit
R	0.0200	
T1 (>0)(sec)	0.3000	
V MAX	0.6250	
V MIN	-0.5000	
T2 (sec)	0.0000	
T3 (>0)(sec)	1.0000	
Dt	30.0000	

Table E.10: System Equivalent Governor Model

F Power Flow Results

Summer Night Valley – 10% Wind Farm Output

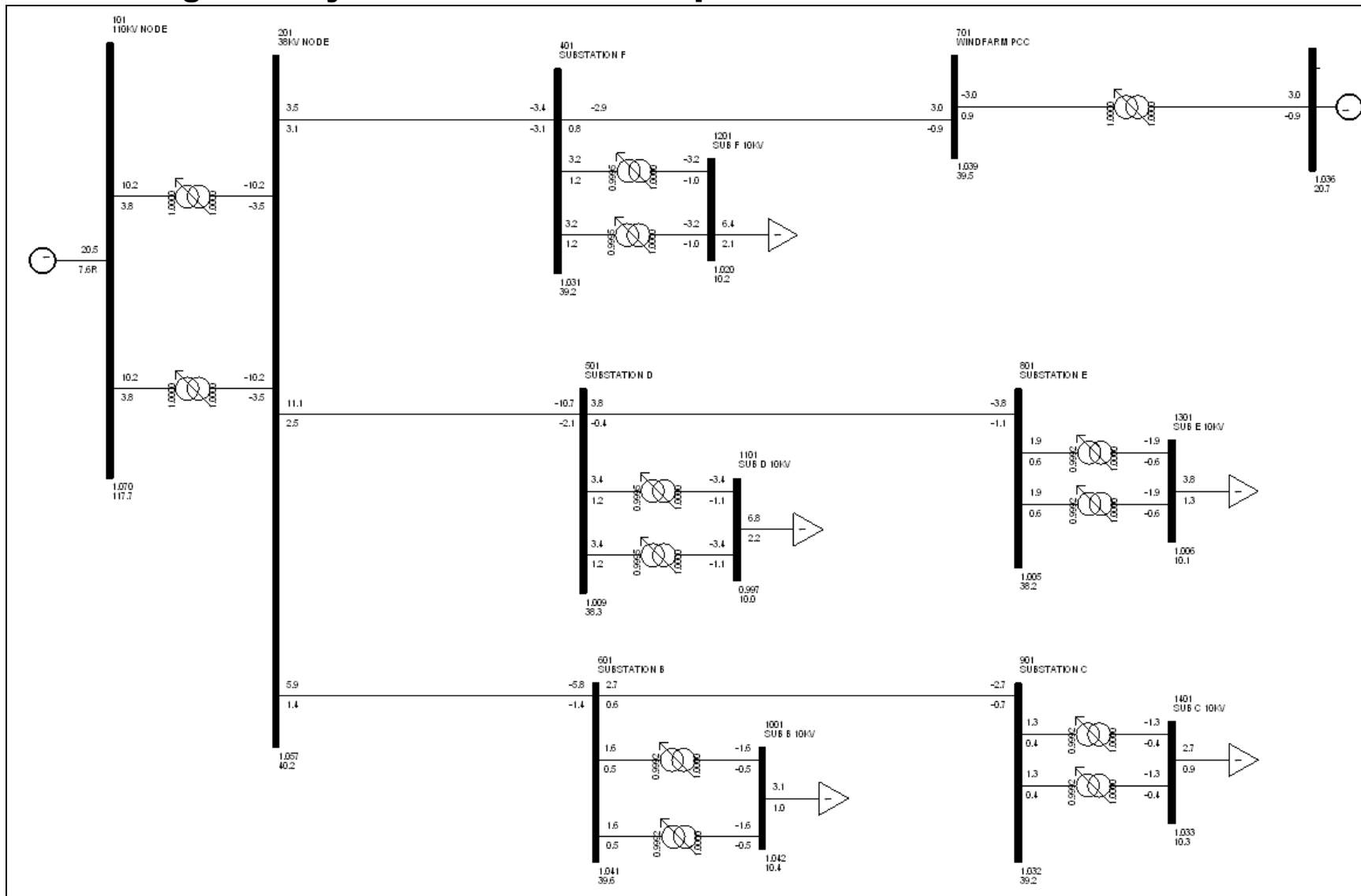

Summer Night Valley – 15% Wind Farm Output

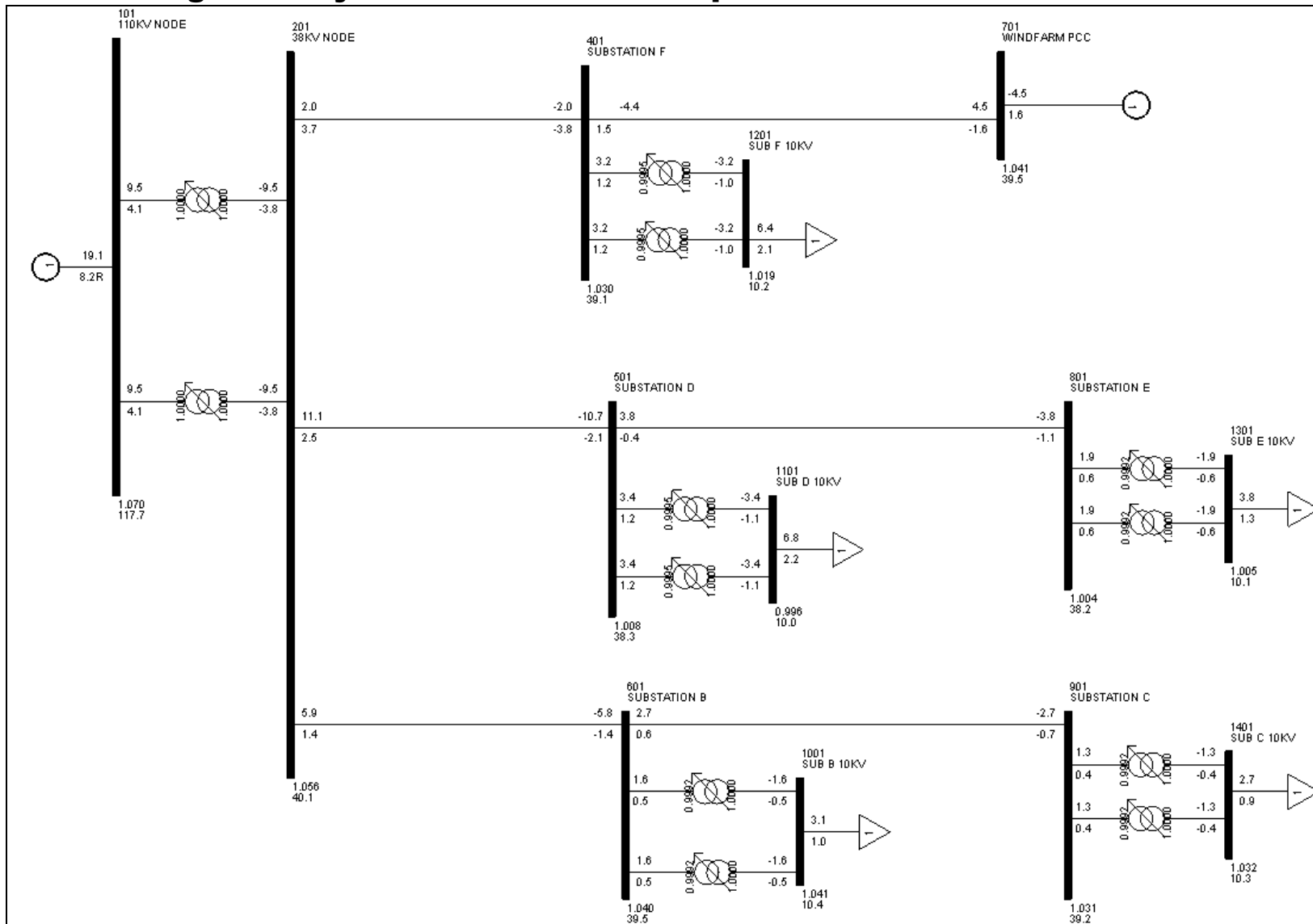

Summer Night Valley – 50% Wind Farm Output

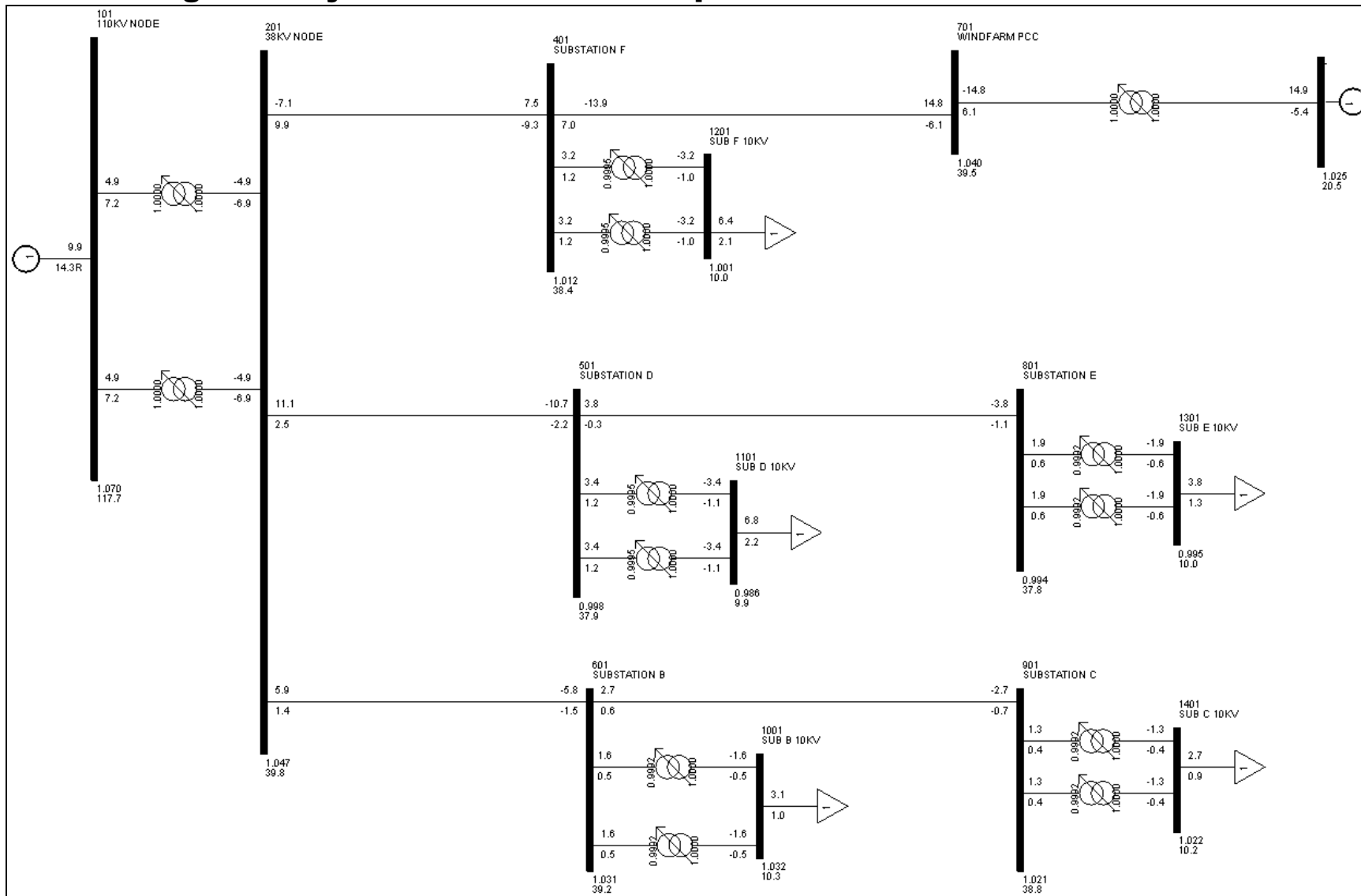

Summer Night Valley – 100% Wind Farm Output

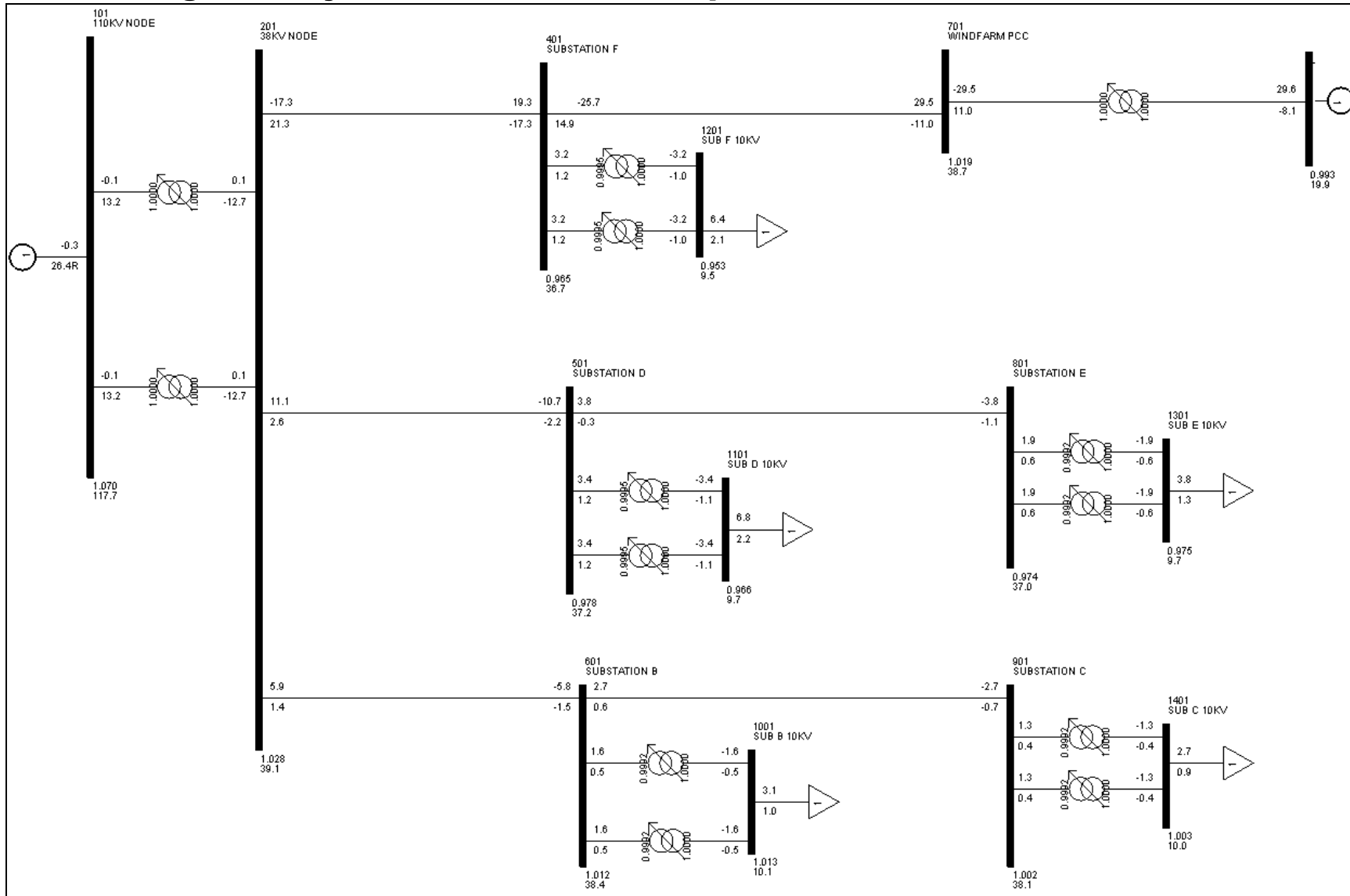

Winter Peak – 10% Wind Farm Output

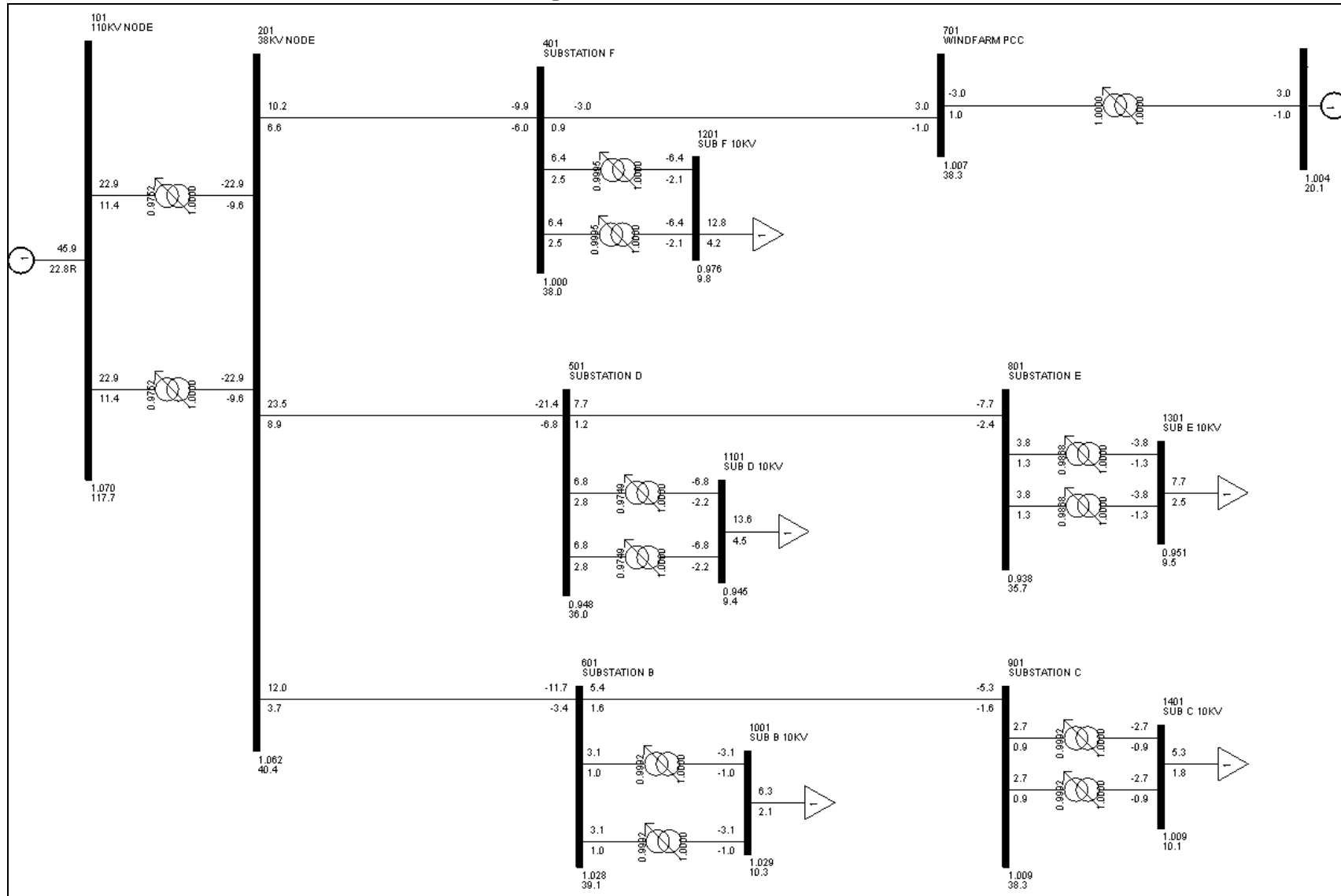

Winter Peak – 15% Wind Farm Output

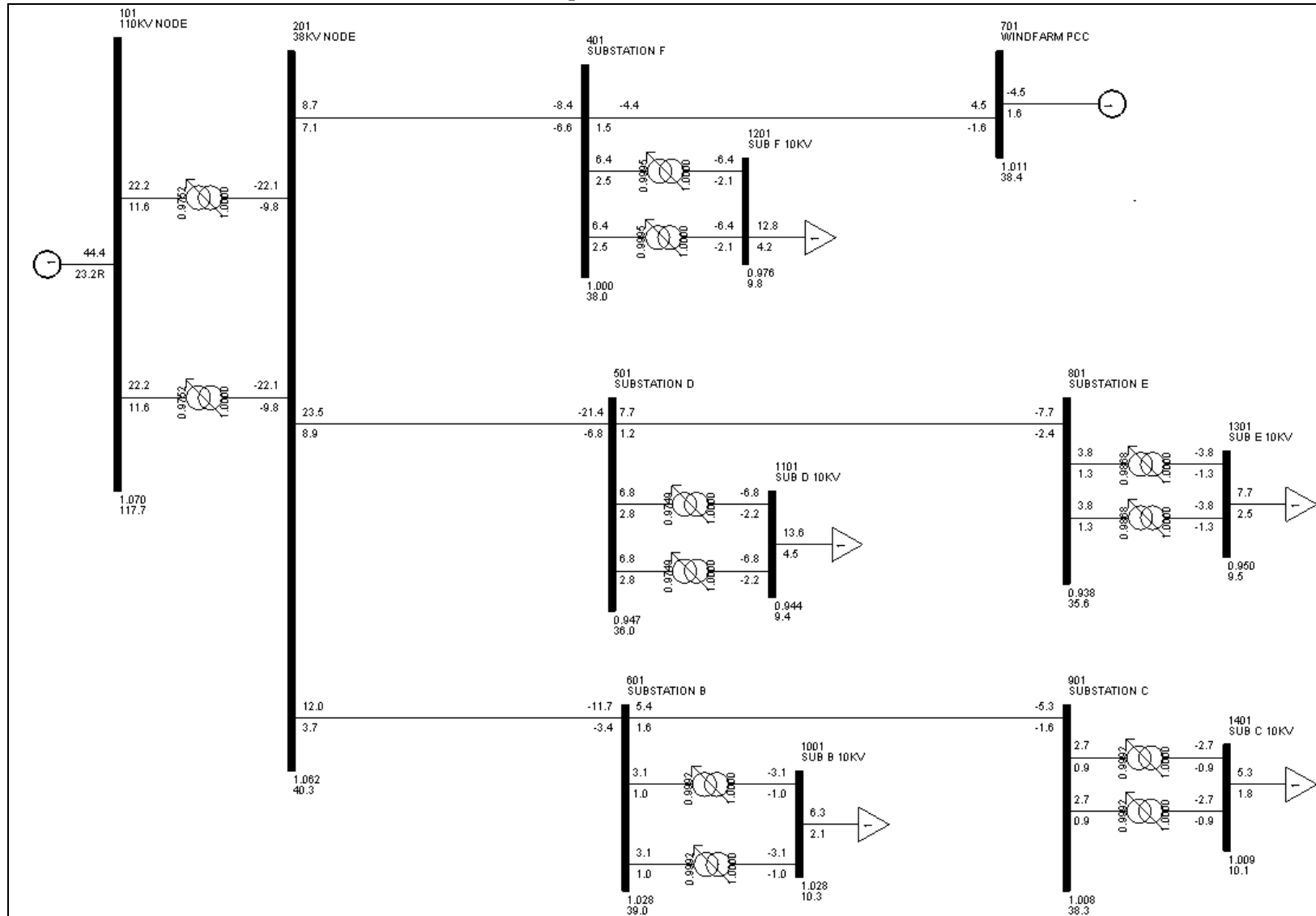

Winter Peak – 50% Wind Farm Output

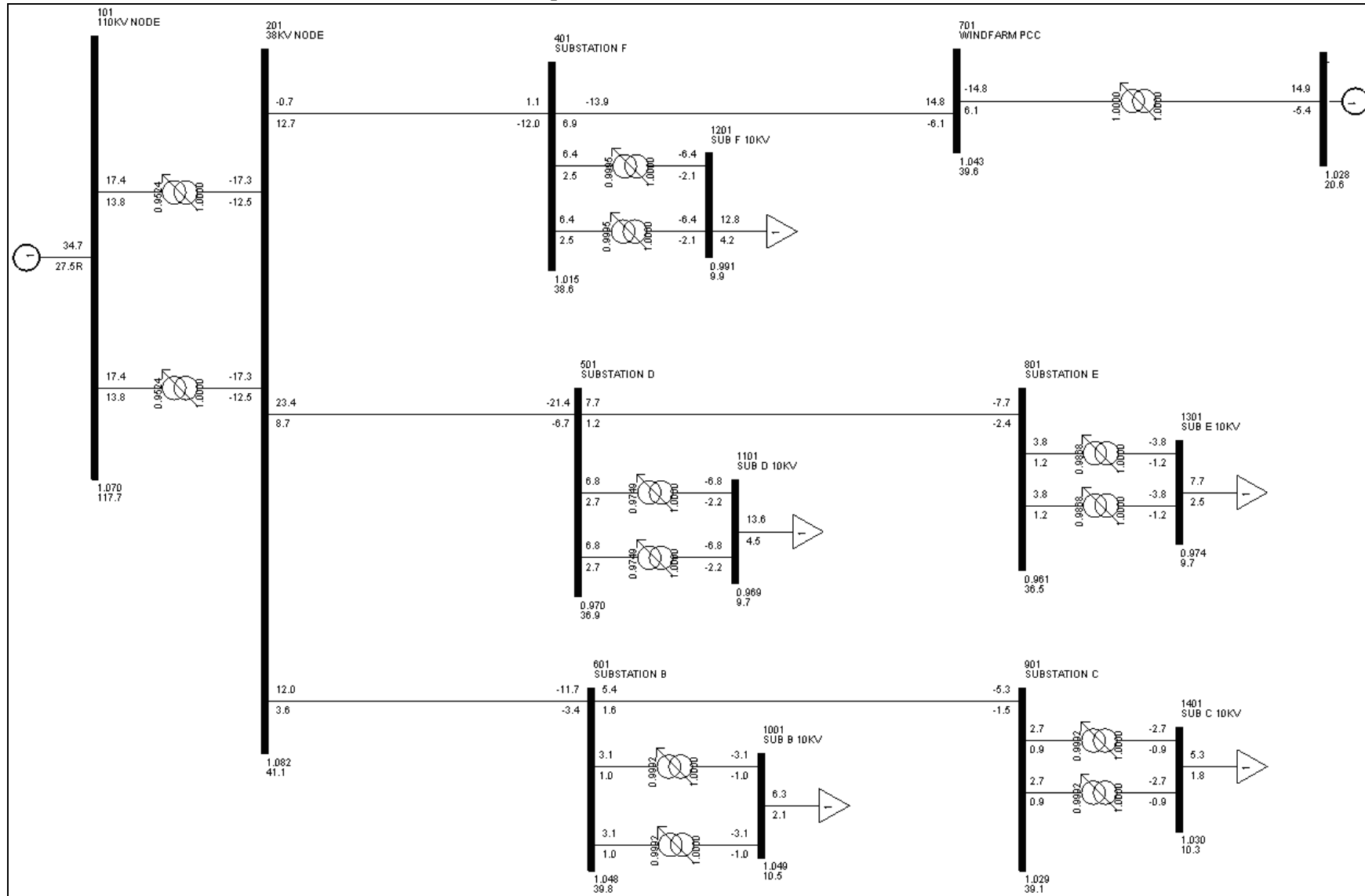

Winter Peak – 100% Wind Farm Output

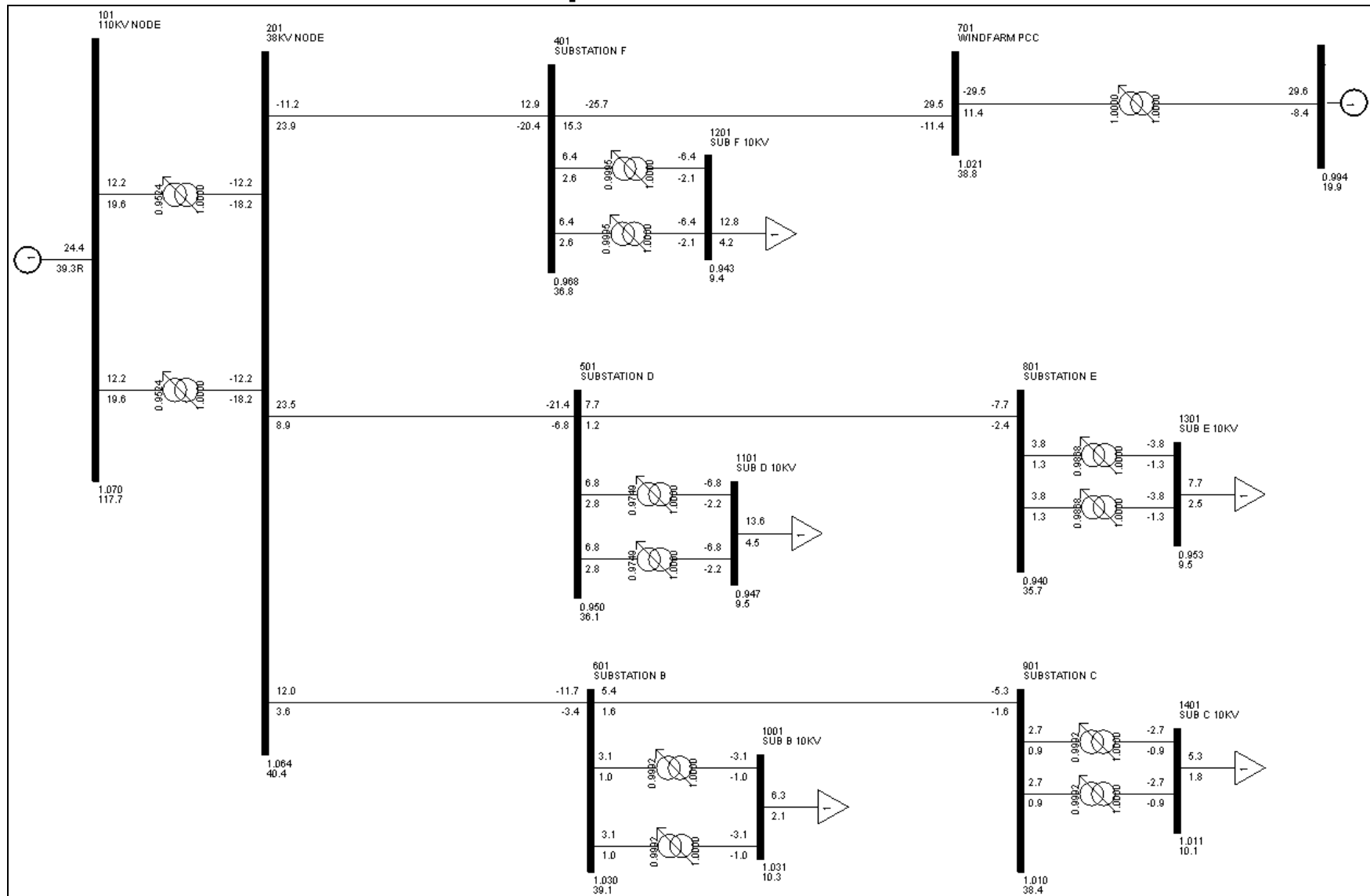

G ESB Networks Interface Protection Requirement

Embedded Generator Protection Requirements

No.	Protection Type	Item	Requirement	
1.	Over and Under Voltage	Voltage variation	+10% to - 10% from nominal	
		Time Delay	Typical < 0.5 ¹ seconds	
		No. Phases	3	
2.	Over and Under Frequency	Frequency variation	+1% to - 4% from 50 Hertz	
		Time Delay	Typical < 0.5 seconds	
		No. Phases	Minimum of 1 phase	
3.	Loss of Mains Note: Where asynchronous machines are used, LOM. Protection may not be required where the installed P.F. Correction is less than 80% of the no load kVAR requirements of the machine.	Operation	For loss of any 1 phase of mains supply	
		Time Delay total	Relay + CB ≤ 0.5 seconds	
		Operation setting	Rate of change of frequency	Typical - 0.4Hz/sec
			Vector shift	Typical - 6 degrees
4.	Directional Overcurrent Note: May not be required if generator rating is: < 1MVA @ MV or < 200kVA @ LV always check with ESB Networks	Setting	No-Export Generators	≤ 50% of Gen. current
			Generators with agreed export	To be agreed with ESB Networks
		Time Delay	< 0.5 ¹ sec as advised by ESB Networks	
		No Phases	Provided on 3 phases by a current based quadrature connected relay with a +45° or +60° RCA.	
5.	Earth Fault Note: In exceptional cases may not be required, always check with ESB Networks	Operation	To trip CB for Earth fault on ESB Networks Distribution system during parallel operation	
		Time Delay	Typically ≤ 30 seconds - or as agreed with ESB Networks	
6.	Relay DC Supply	Failure of Supply	Tripping of main incoming circuit breaker or generator circuit breaker.	
7.	Trip Circuit Supervision	Fault in Trip Circuit	Alarm to be sounded and immediate isolation of the generator	

Table G.1: Embedded Generation Protection Requirements [9]

Embedded Generator Interface Protection Settings

No.	Interface Protection	Monitoring Details	Operating Setting	Trip Time	Notes
1.	Under Voltage	ESB Networks Supply 3Ph	-10%	< 0.5sec Typical	
2.	Over Voltage	ESB Networks Supply 3Ph	+10%	< 0.5sec Typical	
3.	Under Frequency	ESB Networks Supply 1Ph	-4%	< 0.5sec	
4.	Over Frequency	ESB Networks Supply 1PH	+1%	< 0.5sec	
5.	Directional Overcurrent	3 Phase	$\leq 50\%$ or $\leq 120\%$	< 0.5sec	May not be required if Generator Rating is: < 1MVA @ MV PCC or < 200kVA @ LV PCC
6.	Loss of Mains	3 phase, or 1 phase + asymmetry relay	Typical 0.4Hz/sec Typical 6 Degrees	< 0.5sec < 0.5sec	Rate of Change of Frequency (ROCOF) and/or Vector Shift
7.	Earth Fault	ESB Networks MV or 38kV Supply (Depending on PCC)	30% NVD	$\leq 30\text{sec}$	

Table F.G: Embedded Generation Interface Protection Settings [9]

Wind Generator Interface Protection Settings

No.	Interface Protection	Monitoring Details	Operating Setting	Trip Time	Notes
1.	Under Voltage	ESB Networks Supply 3Ph	-20% [80% retained]	1s	
3.	Under Frequency	ESB Networks Supply 3Ph	47 Hz	0.5sec	
4.	Over Frequency	ESB Networks Supply 3PH	50.8 Hz	0.5sec	
6.	Loss of Mains	3 phase	0.55 Hz/sec	< 0.5sec	Rate of Change of Frequency (ROCOF)

Table G.3: Wind Generation Protection Requirements [9]

H Irish Power System Data

System Records

	Value	Day of Week	Effective Date
Winter Night Valley	2928 MW	Wednesday	22-12-10
Summer Night Valley	1786 MW	Monday	04-08-08
Mid-day Peak	4410 MW	Tuesday	21-12-10
Evening Peak	5090 MW	Tuesday	21-12-10
Saturday Peak	4524 MW	Saturday	09-01-10
Sunday Peak	4335 MW	Sunday	10-01-10
Maximum Wind	1323 MW	Monday	04-04-11

Figure H.1: System Records [42]

Wind Generation Capacity Growth in Ireland 1992 – 2016

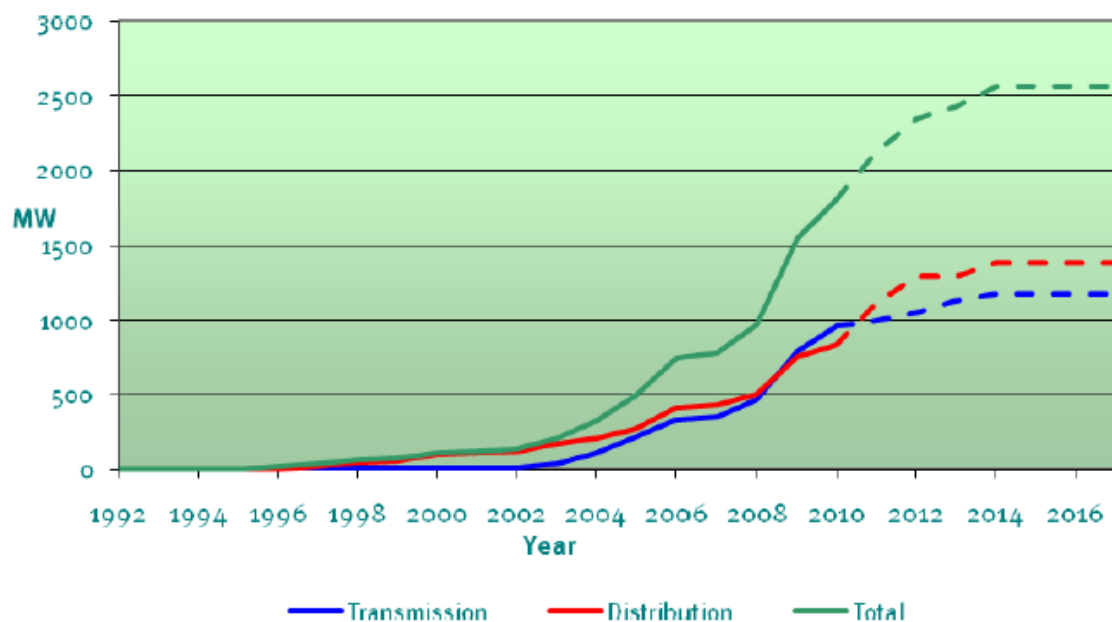

Connection	2010	2011	2012	2013	2014	2015	2016	2017
Transmission	966	1,000	1,052	1,134	1,180	1,180	1,180	1,180
Distribution	839	1120	1293	1293	1383	1383	1383	1383
Total	1,805	2,120	2,345	2,427	2,563	2,563	2,563	2,563

Figure H.2: Wind Generation Capacity Growth in Ireland 1992 -2016 [39]

System Demand Vs Wind Generation - 4th of April 2011

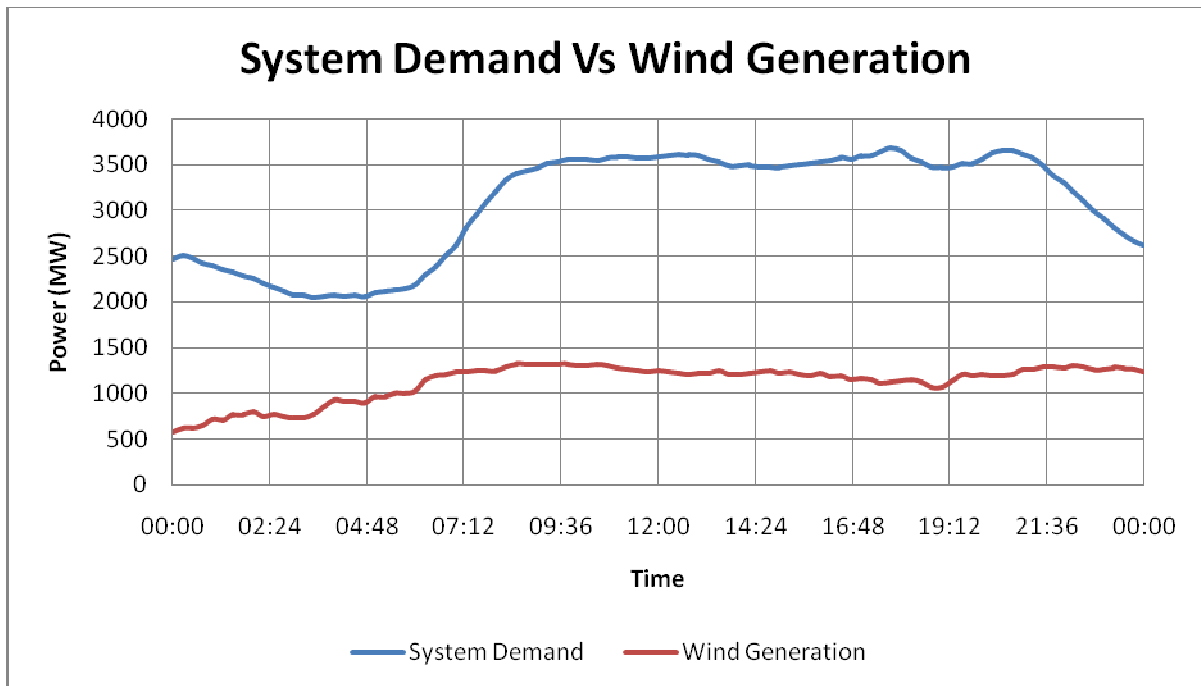

Figure H.3: System Demand Vs Wind Generation – 4th of April 2011 [43]

Wind Contribution - 4th of April 2011

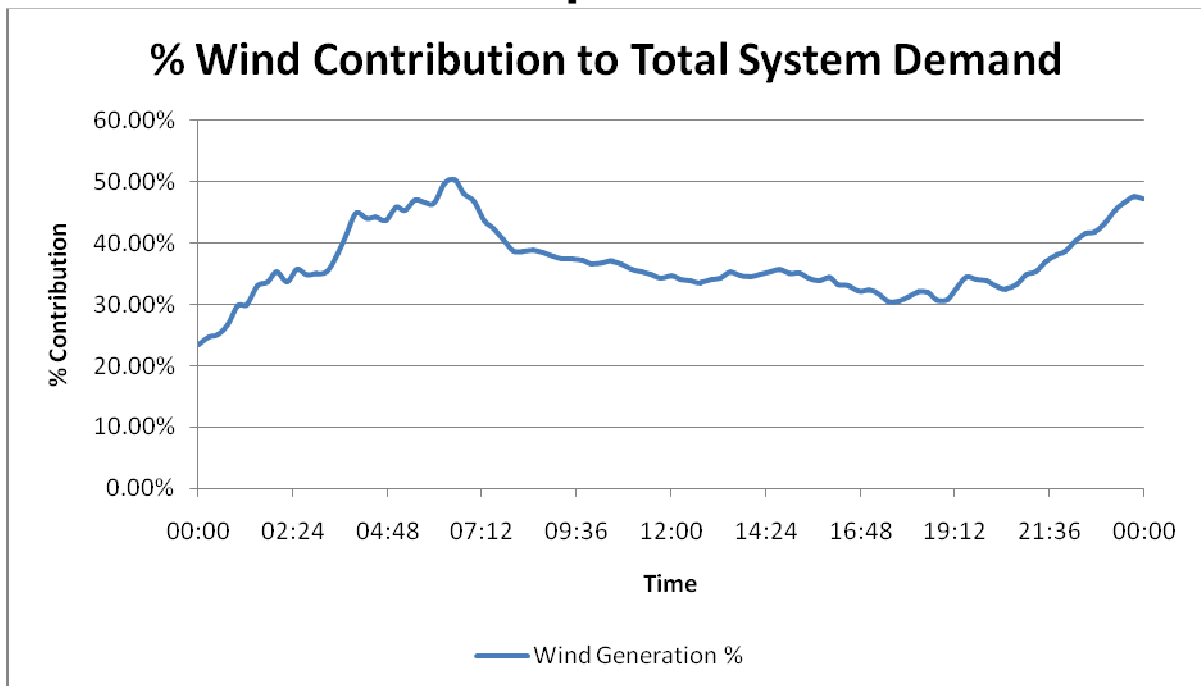

Figure H.4: % Wind Contribution to Total System Demand – 4th of April 2011

I **Dynamic Results**

Fault Analysis

Scenario 1A – 110kV System Faults

Details:

Fault Type: Single Line to Ground Fault

Fault Duration: 100ms Duration

Results: Summer Night Valley

Wind Farm Output: 15%

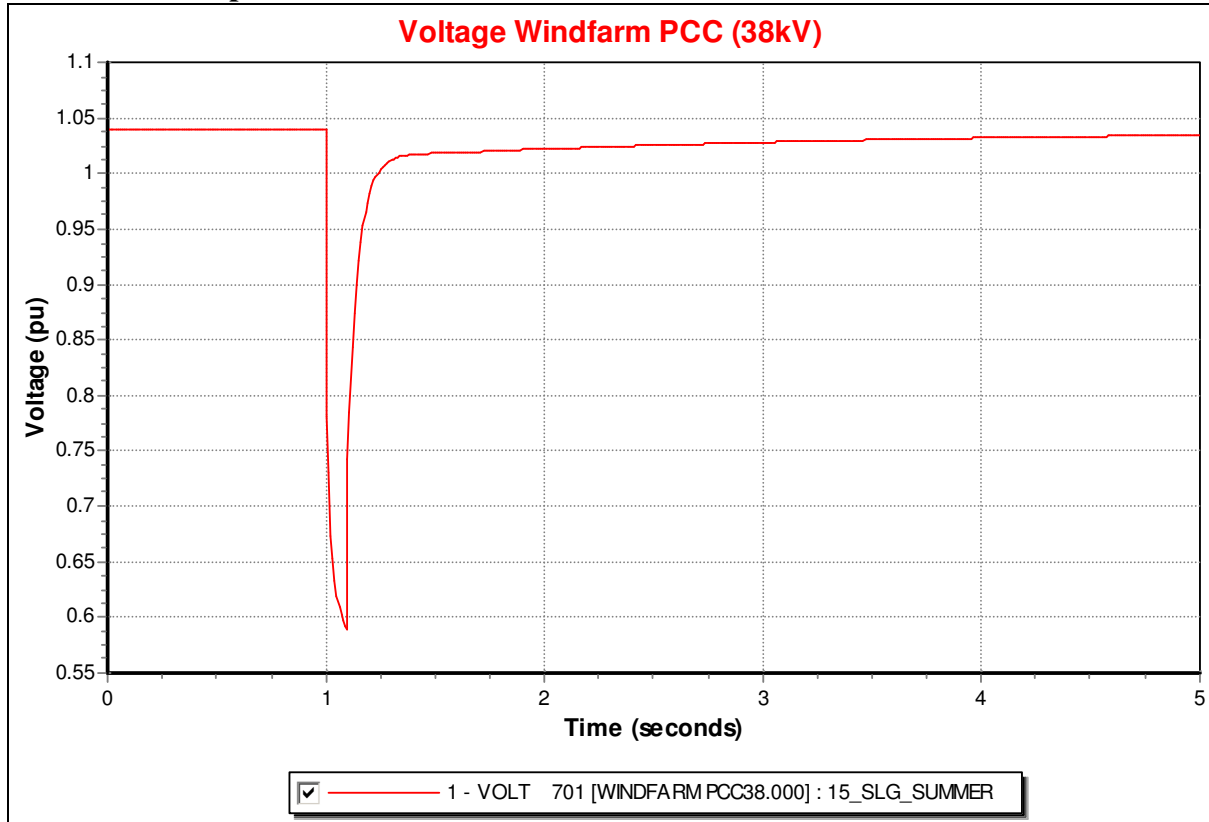

Wind Farm Output: 50%

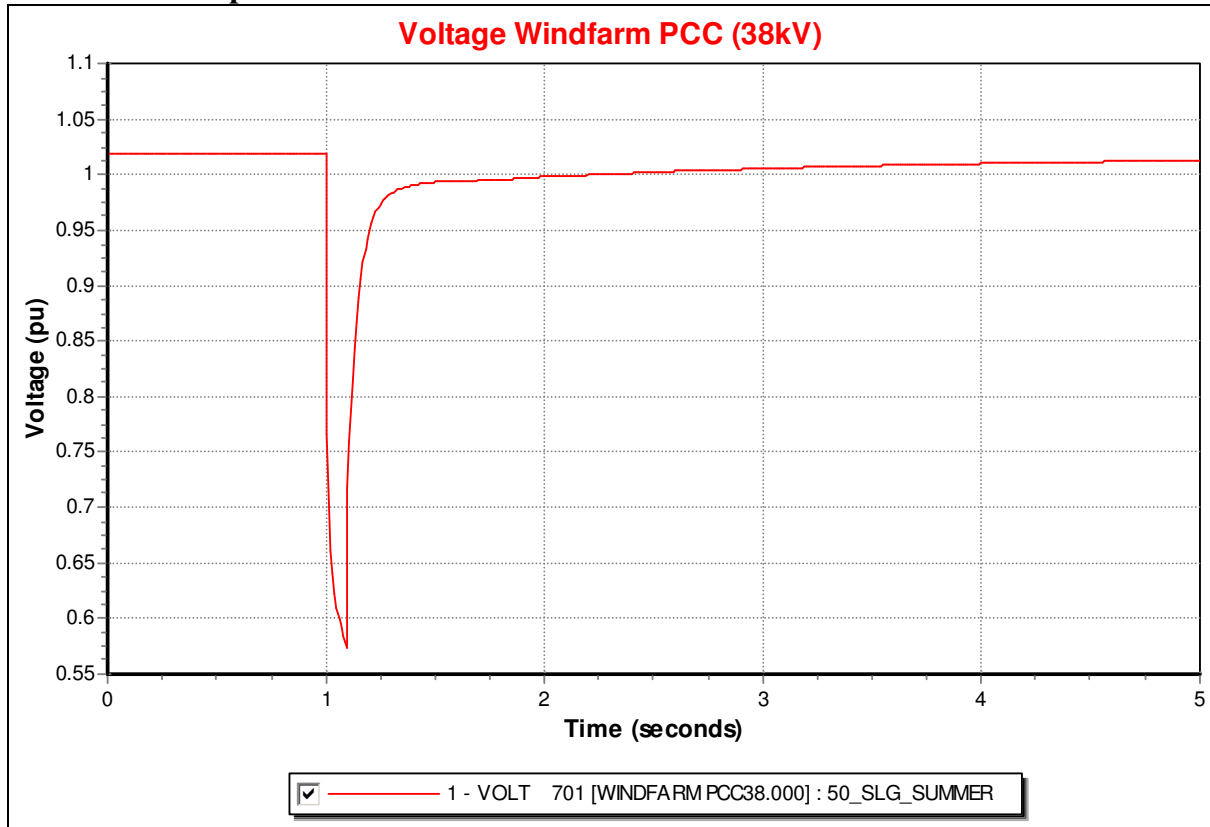

Wind Farm Output: 100%

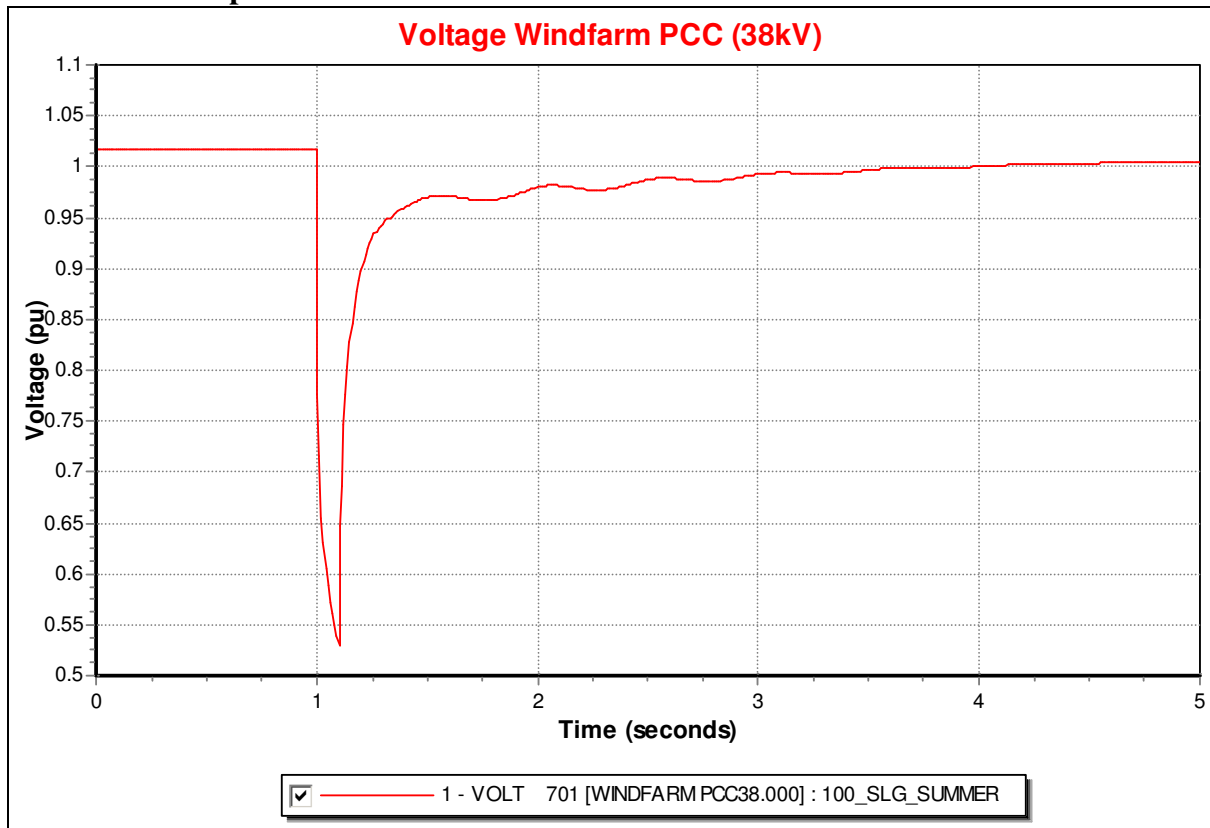

Results: Winter Peak
Wind Farm Output: 15%

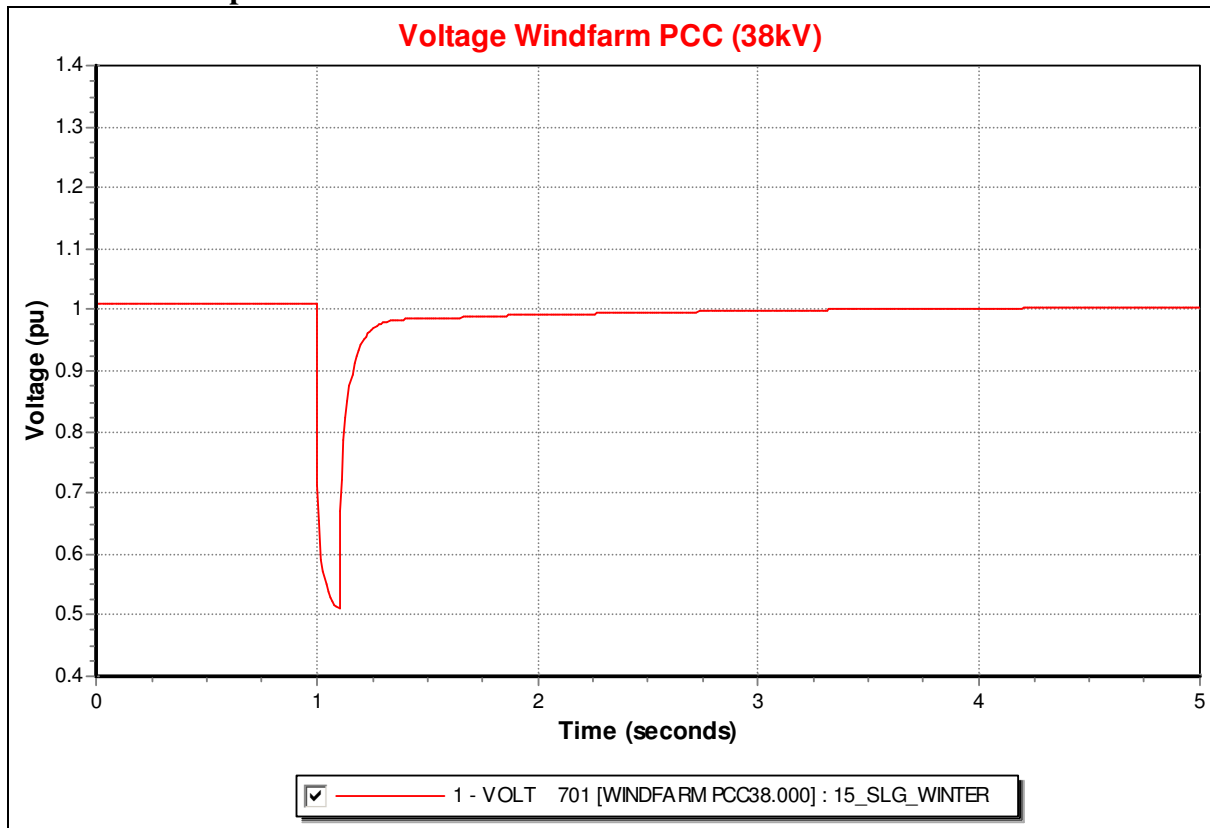

Wind Farm Output: 50%

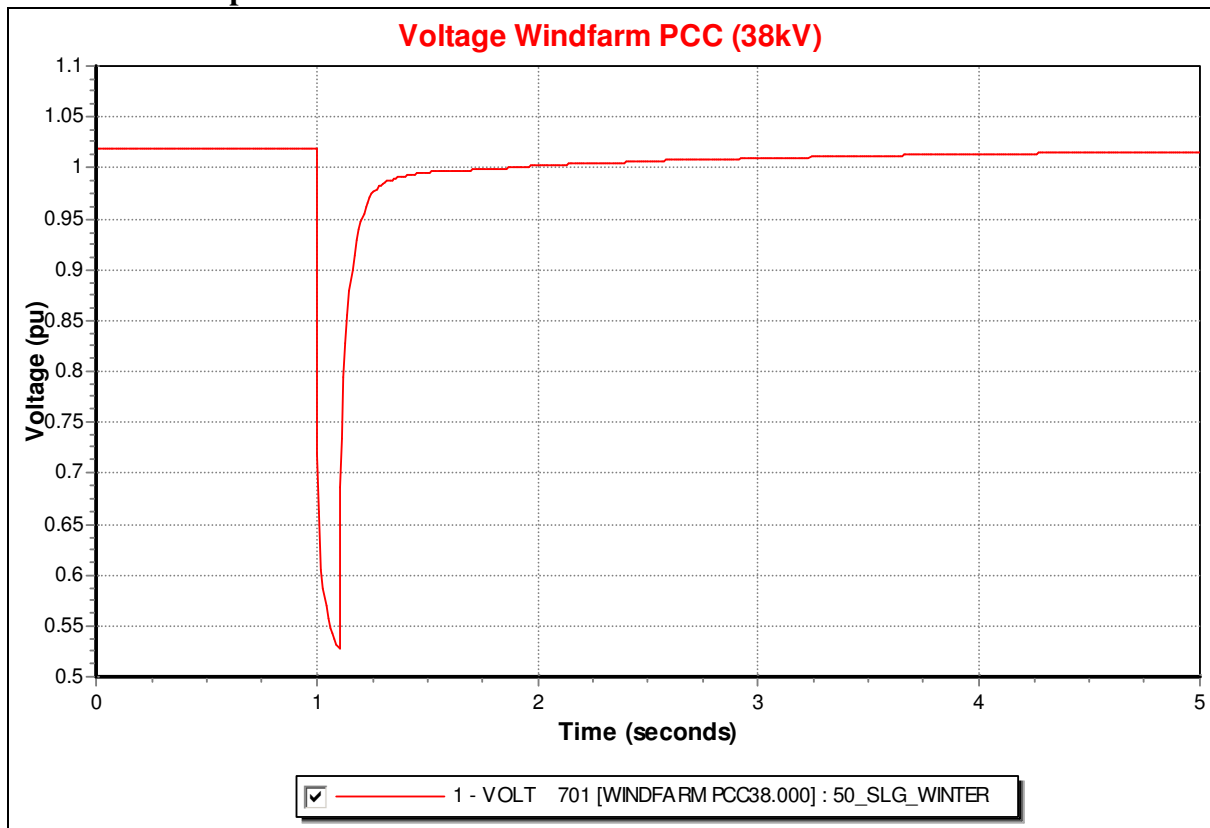

Wind Farm Output: 100%

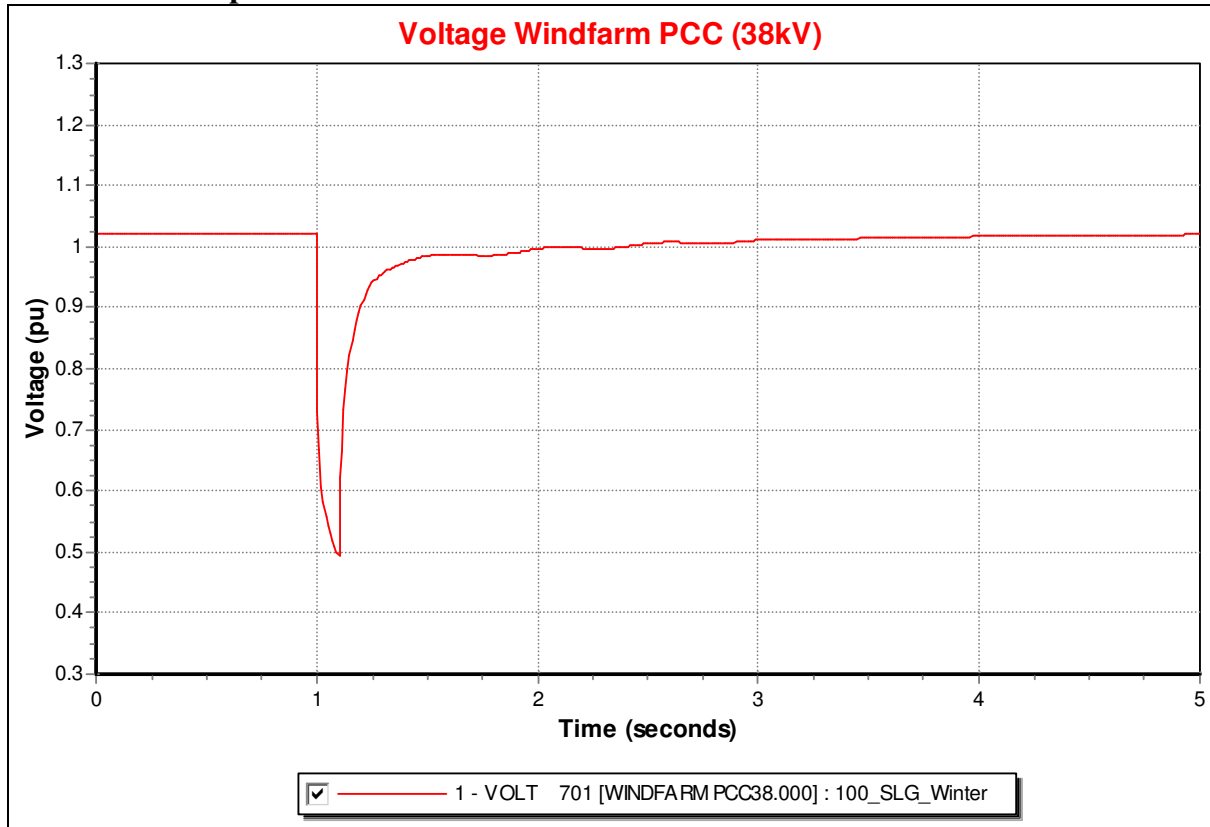

Scenario 1B – 110kV System Faults

Details:

Fault Type: Line to Line Fault

Fault Duration: 100ms Duration

Results: Summer Night Valley

Wind Farm Output: 15%

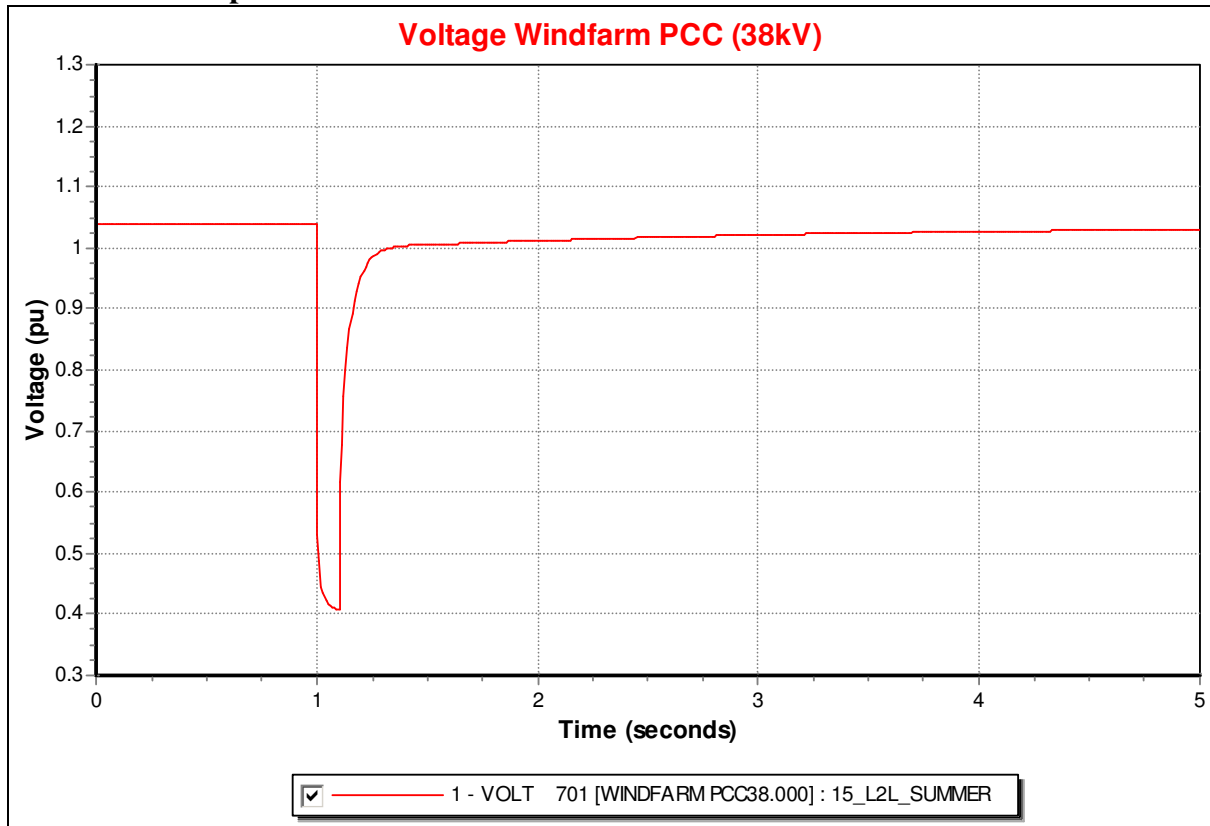

Wind Farm Output: 50%

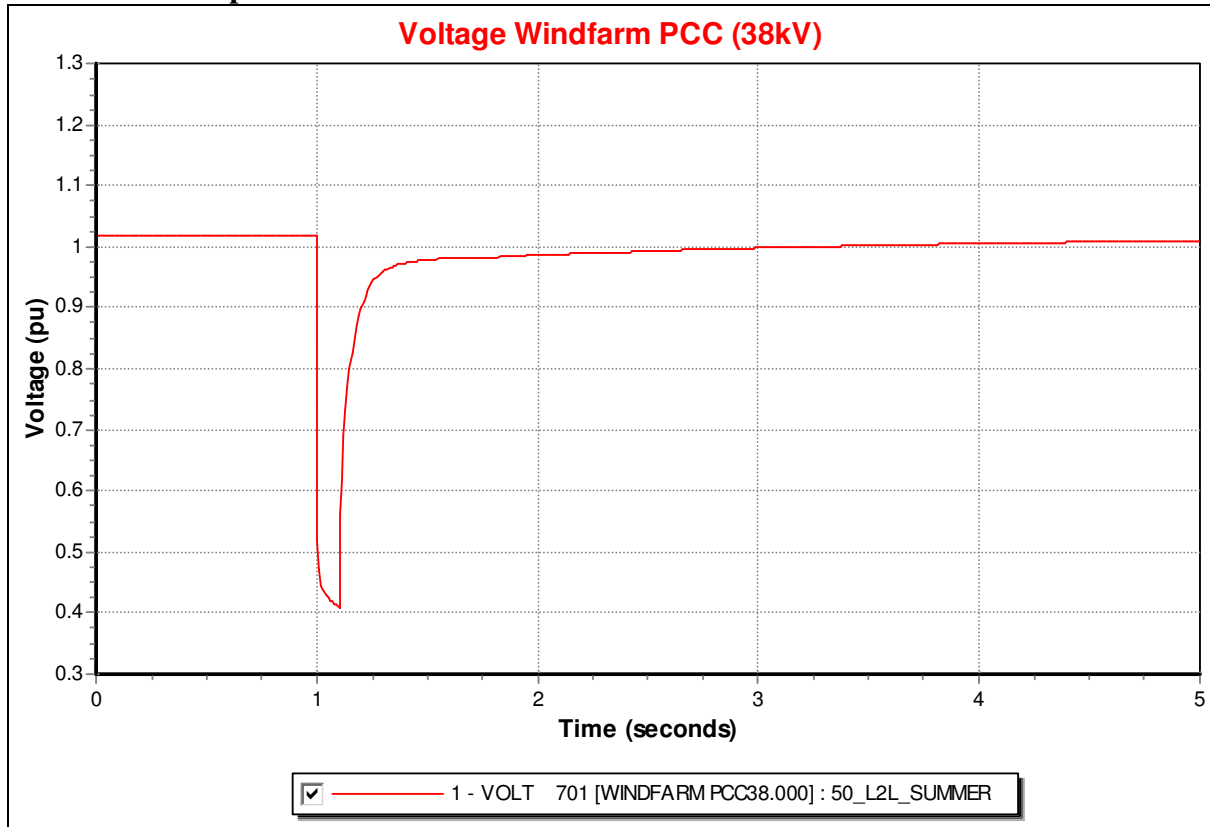

Wind Farm Output: 100%

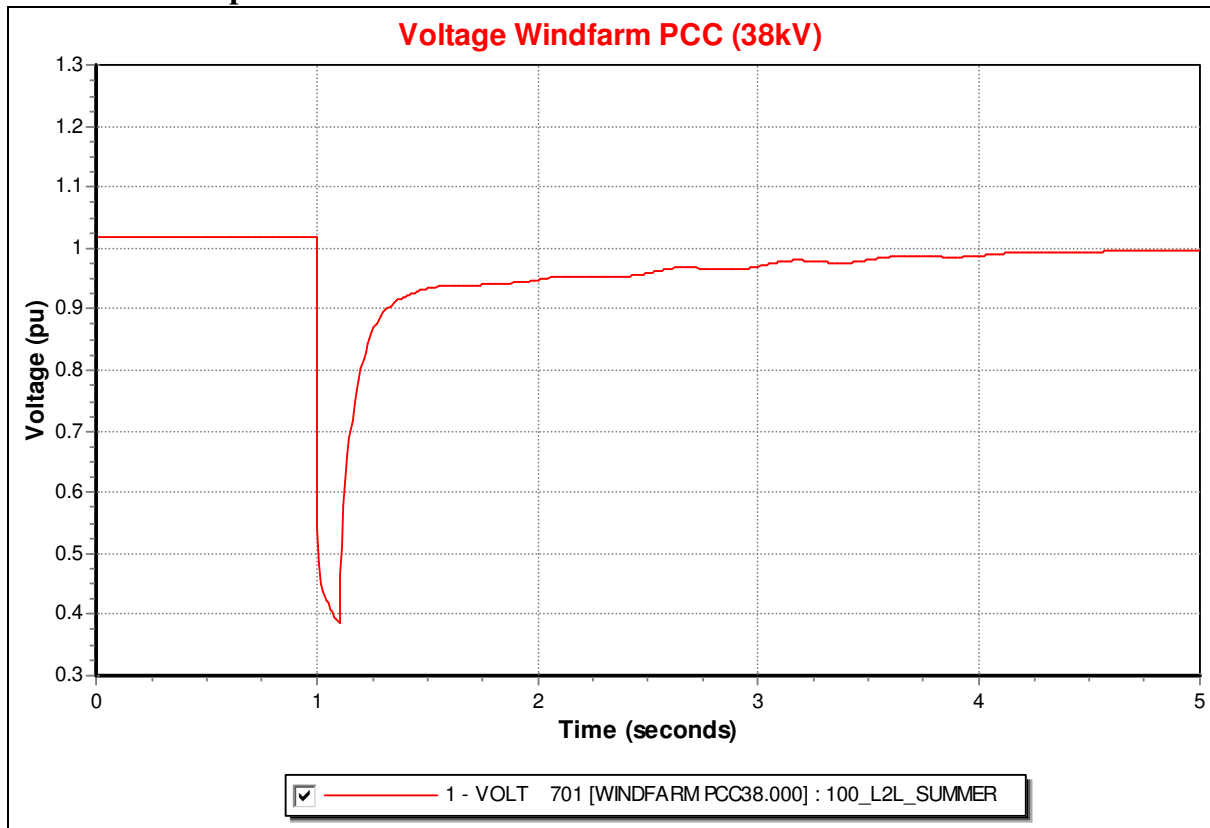

Results: Winter Peak Results
Wind Farm Output: 15%

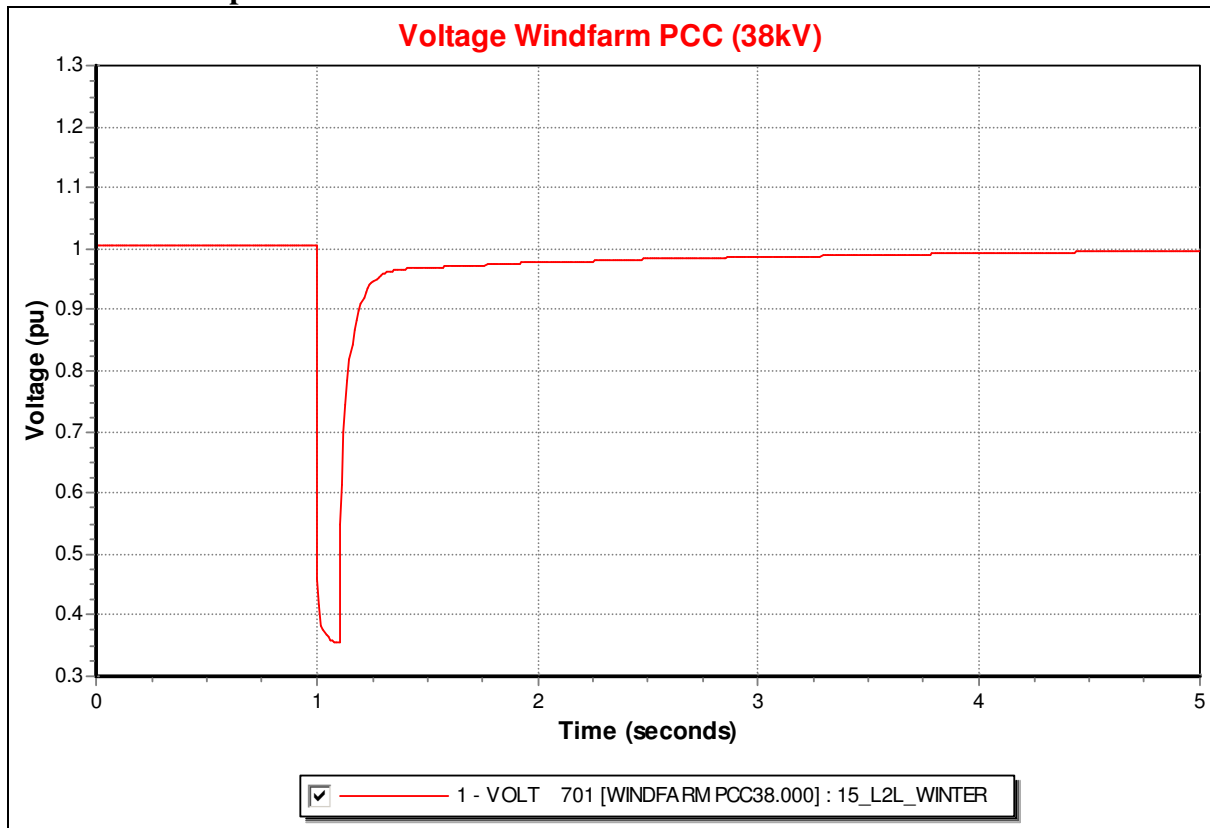

Wind Farm Output: 50%

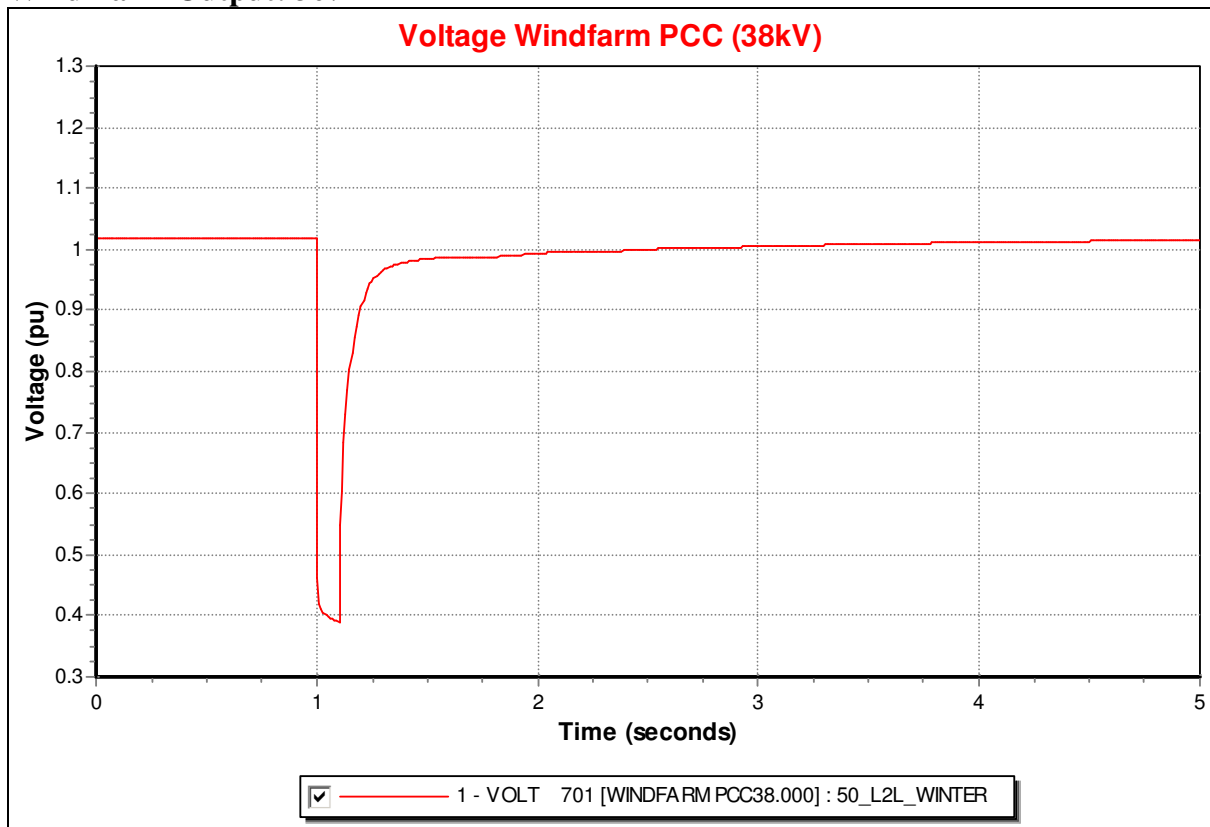

Wind Farm Output: 100%

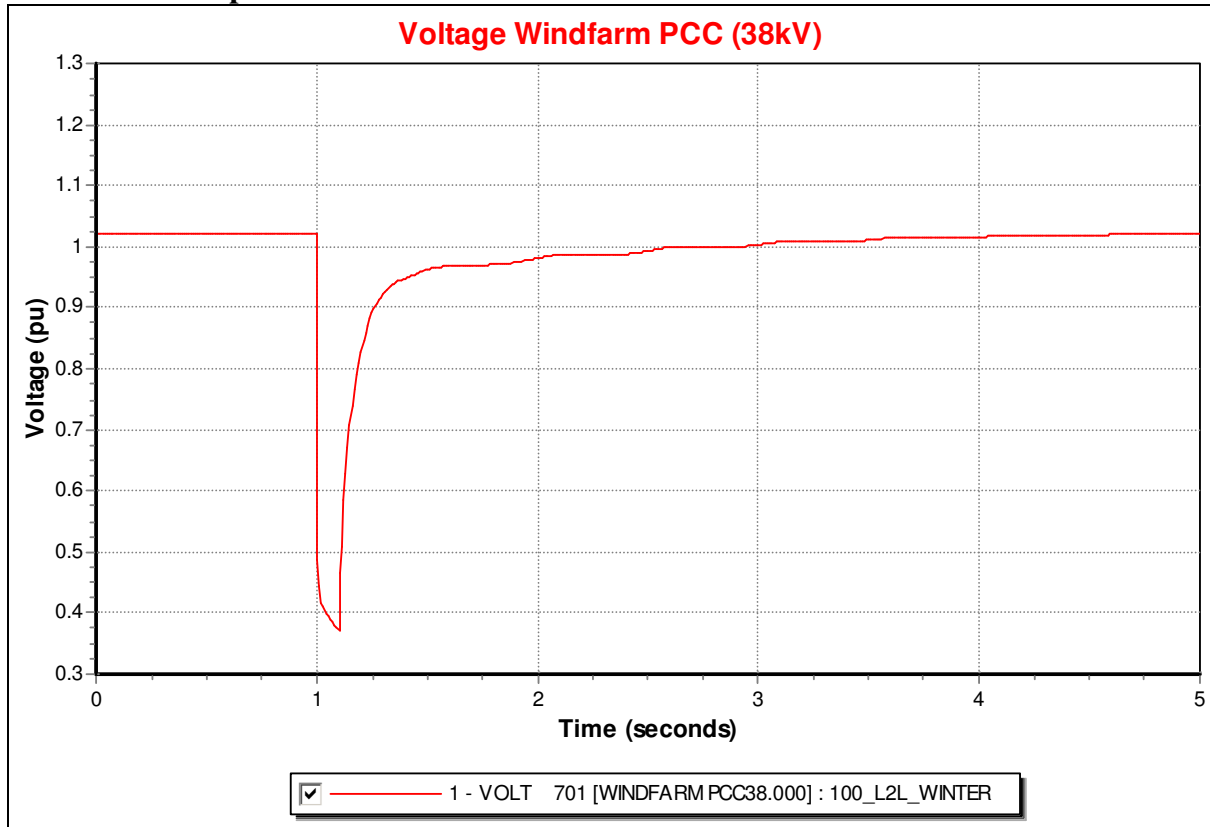

Blank Page

Scenario 2 – 38kV System Faults

Details:

Fault Type: Line to Line Fault

Fault Duration: 500ms Duration

Results: Summer Night Valley

Wind Farm Output: 15%

Fault Location: Substation B (Node 601)

Existing Windfarm Interface Protection Trip: Yes

Proposed Windfarm Interface Protection Trip: No

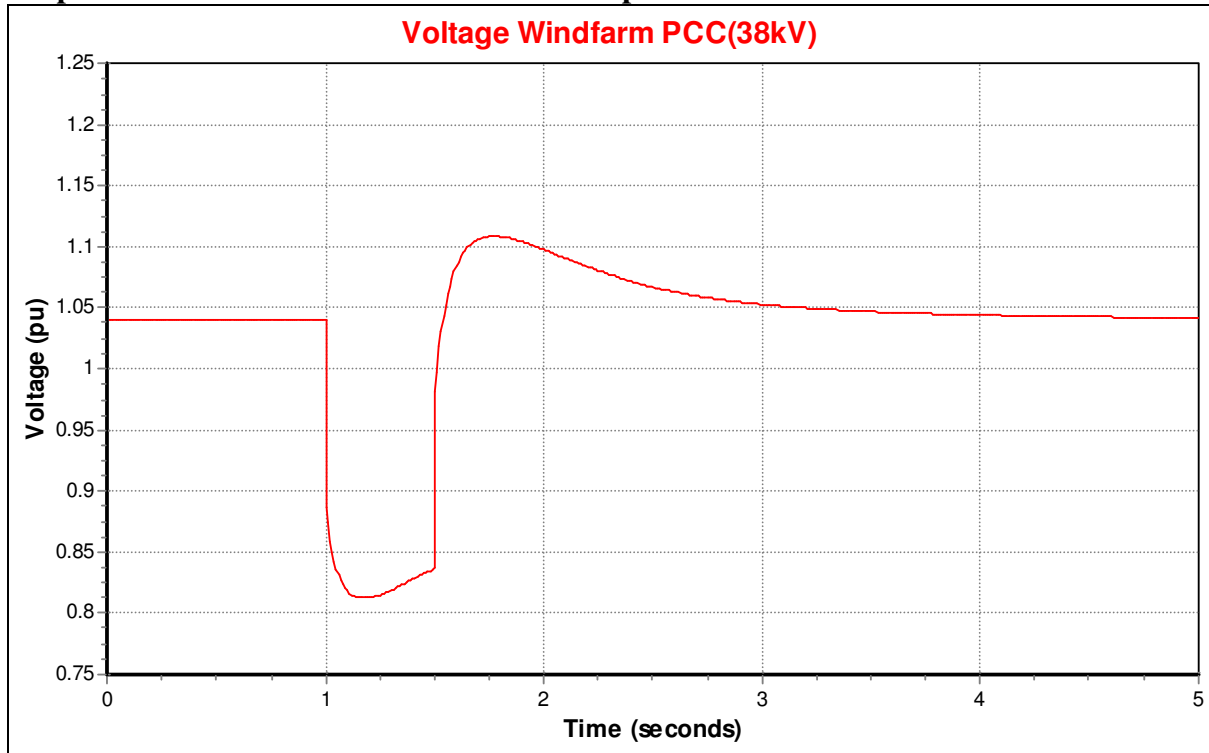

Fault Location: Substation C (Node 901)
Existing Windfarm Interface Protection Trip: No
Proposed Windfarm Interface Protection Trip: No

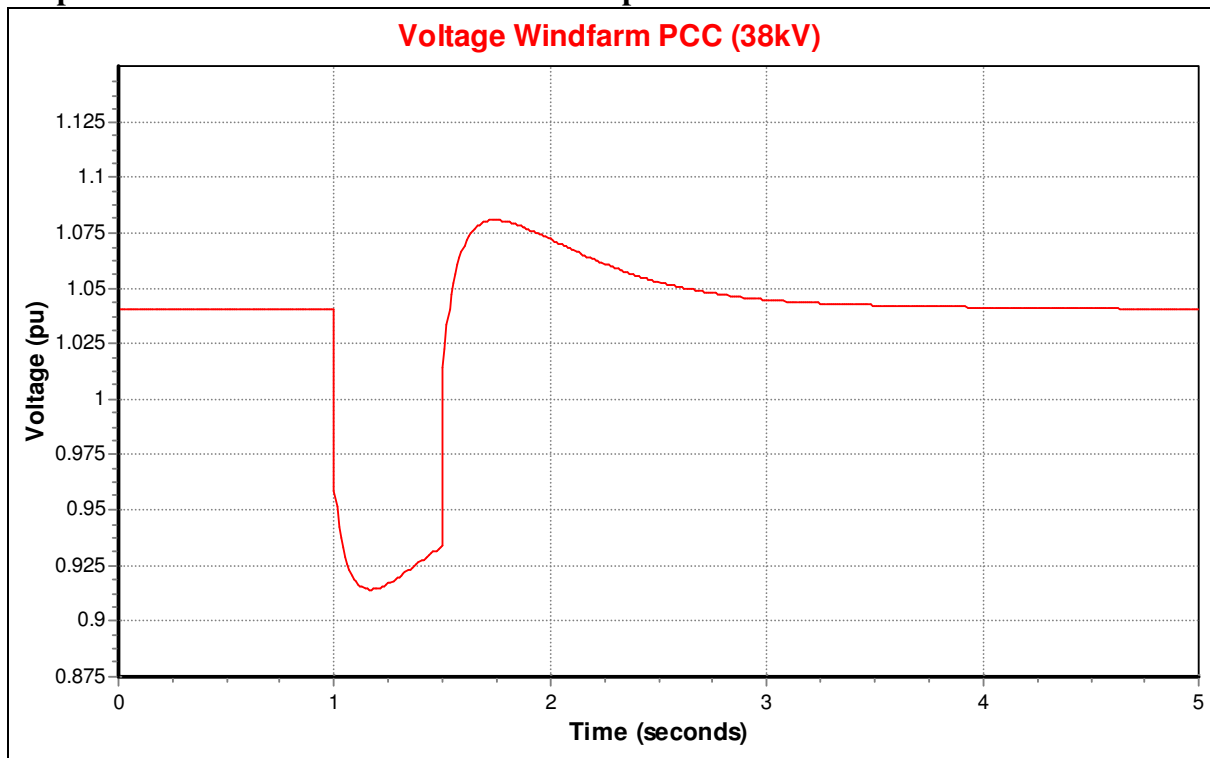

Fault Location: Substation D (Node 501)
Existing Windfarm Interface Protection Trip: No
Proposed Windfarm Interface Protection Trip: No

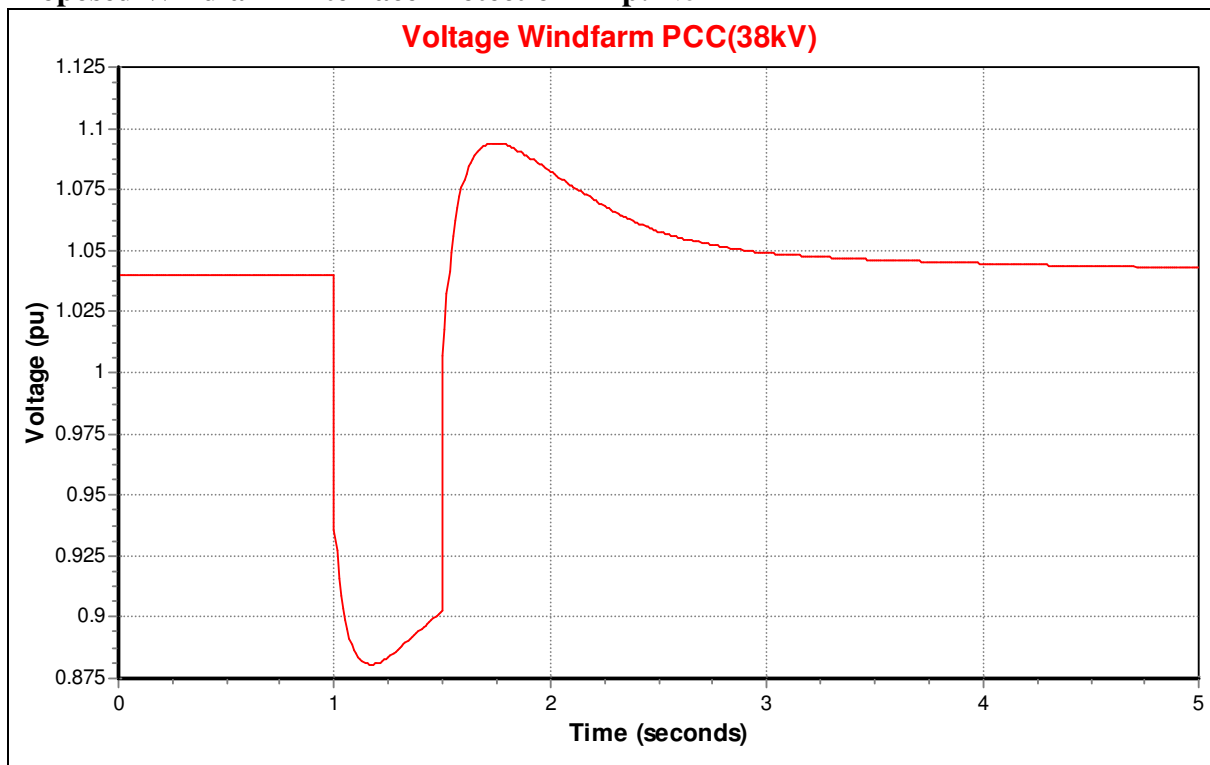

Fault Location: Substation E (Node 801)
Existing Windfarm Interface Protection Trip: No
Proposed Windfarm Interface Protection Trip: No

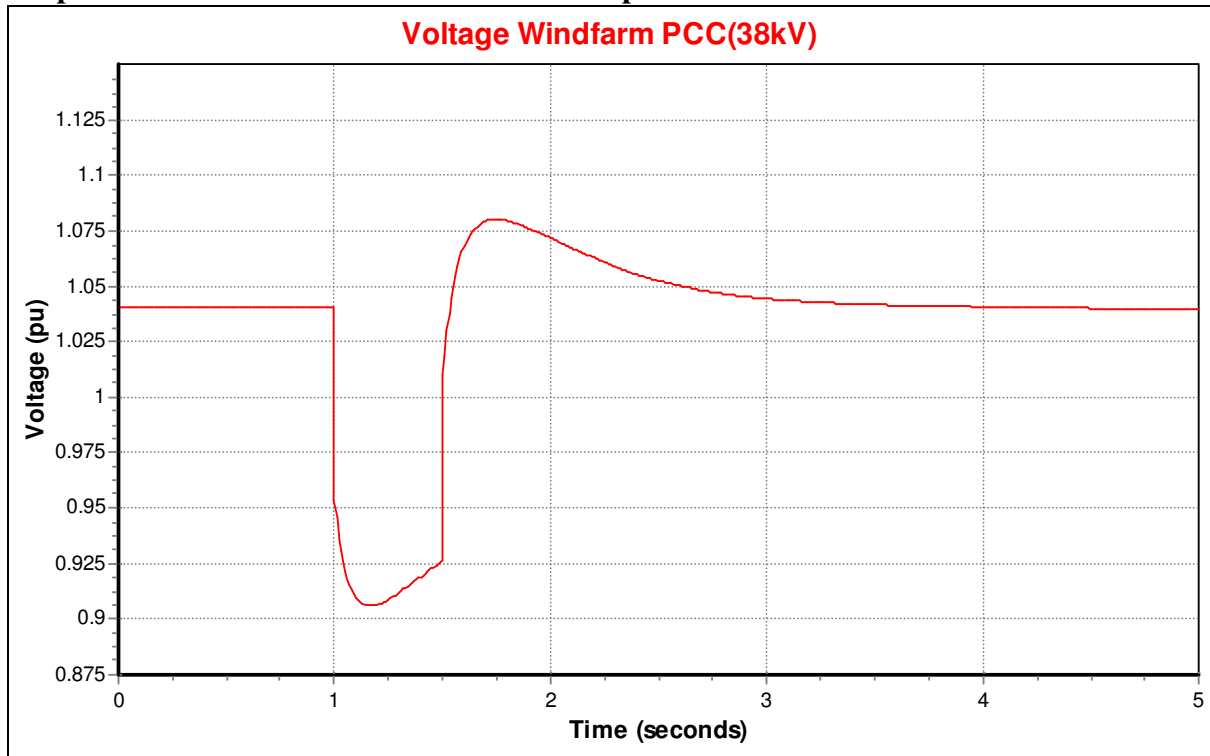

Fault Location: Substation F (Node 401)
Existing Windfarm Interface Protection Trip: Yes
Proposed Windfarm Interface Protection Trip: Yes

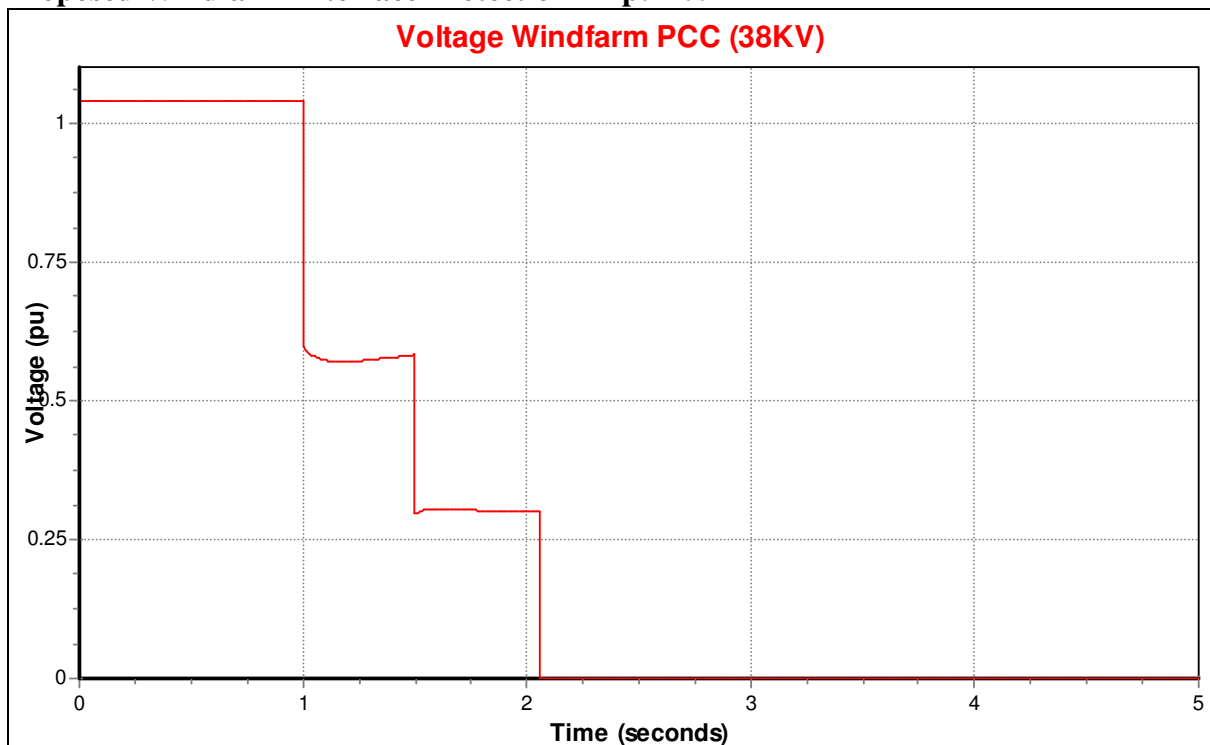

Details:

Fault Type: Line to Line Fault

Fault Duration: 500ms Duration

Results: Summer Night Valley

Wind Farm Output: 100%

Fault Location: Substation B (Node 601)

Existing Windfarm Interface Protection Trip: No

Proposed Windfarm Interface Protection Trip: No

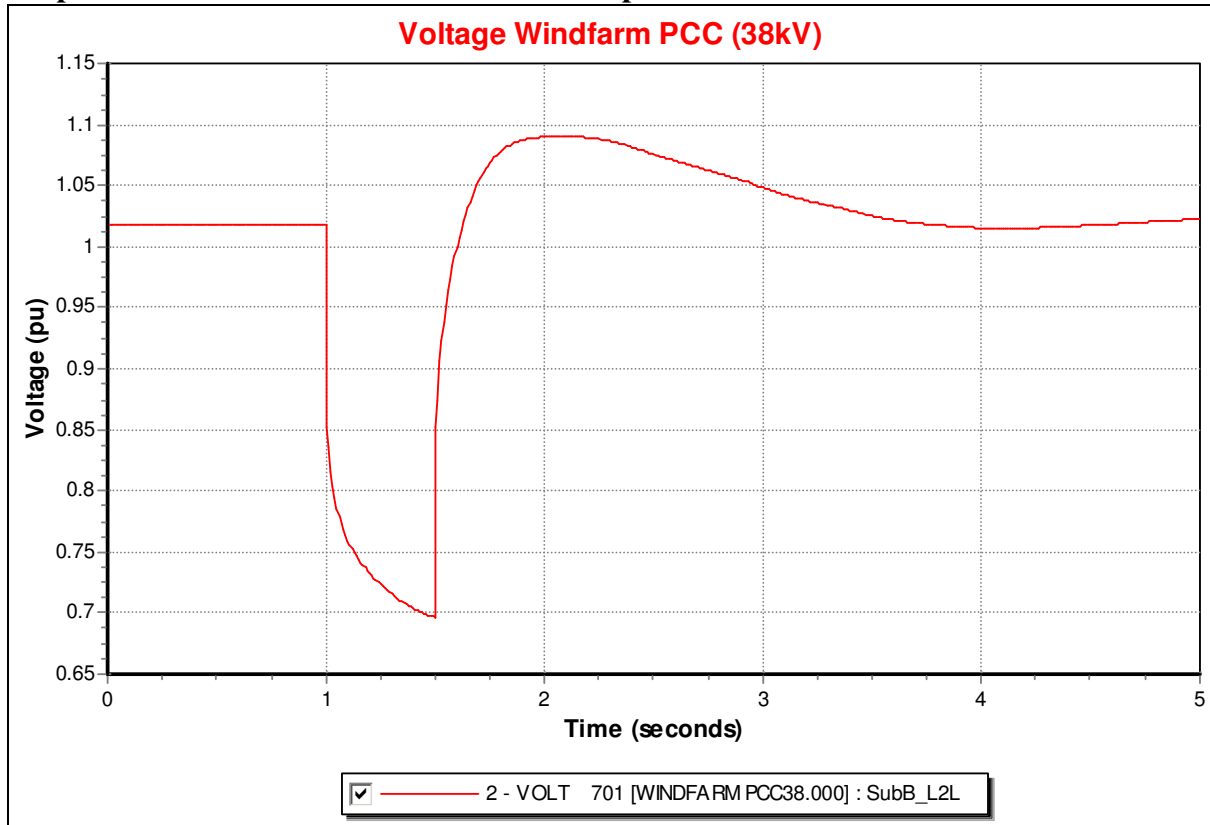

Fault Location: Substation C (Node 901)
Existing Windfarm Interface Protection Trip: No
Proposed Windfarm Interface Protection Trip: No

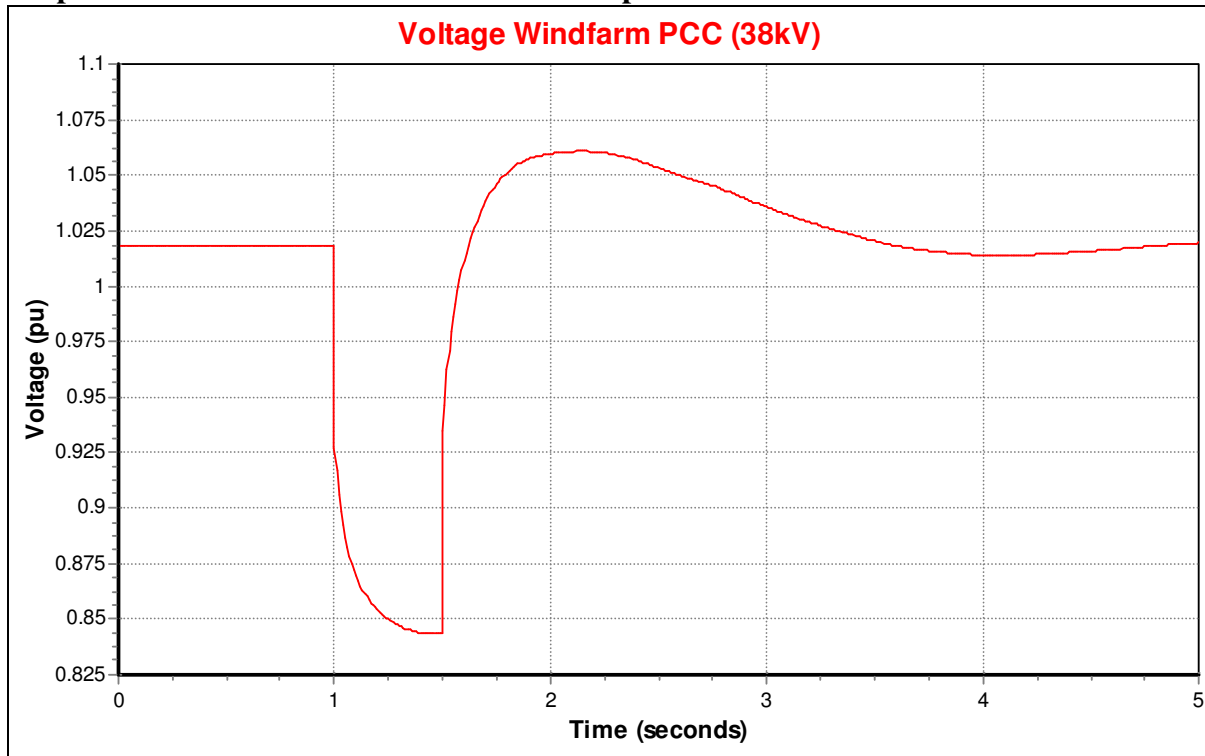

Fault Location: Substation D (Node 501)
Existing Windfarm Interface Protection Trip: No
Proposed Windfarm Interface Protection Trip: No

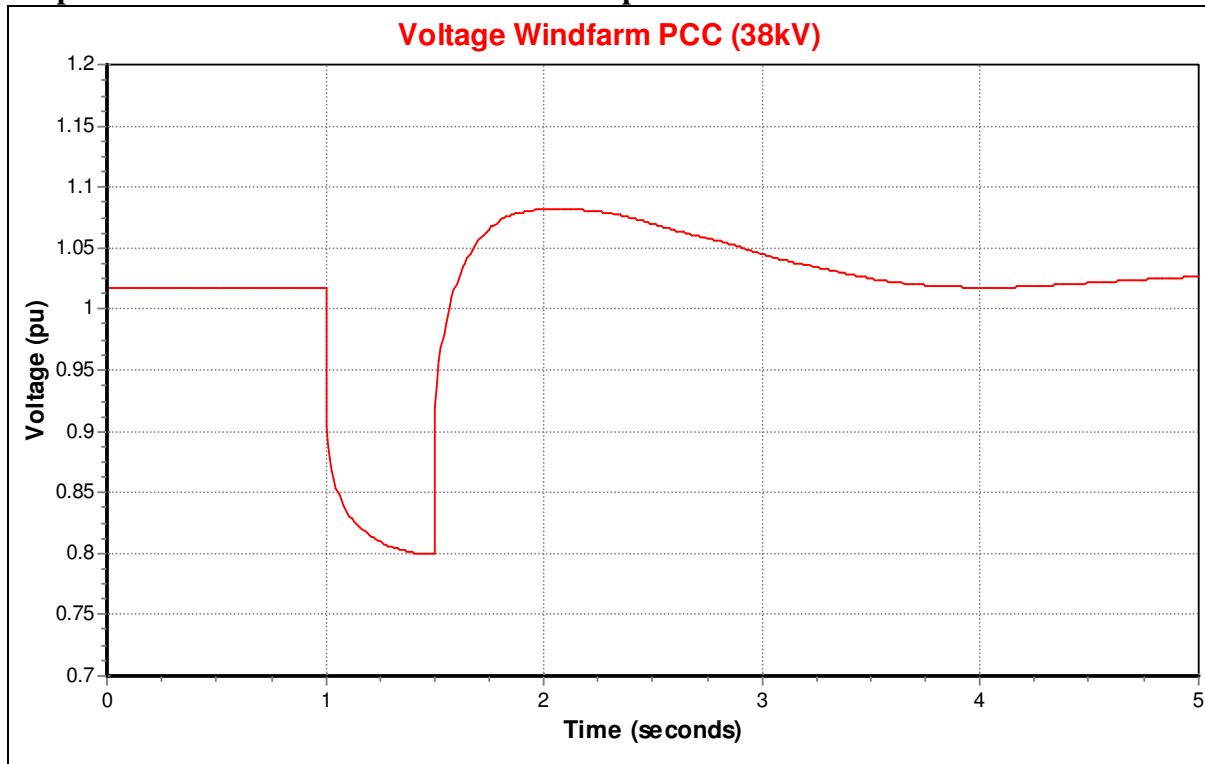

Fault Location: Substation E (Node 801)
Existing Windfarm Interface Protection Trip: No
Proposed Windfarm Interface Protection Trip: No

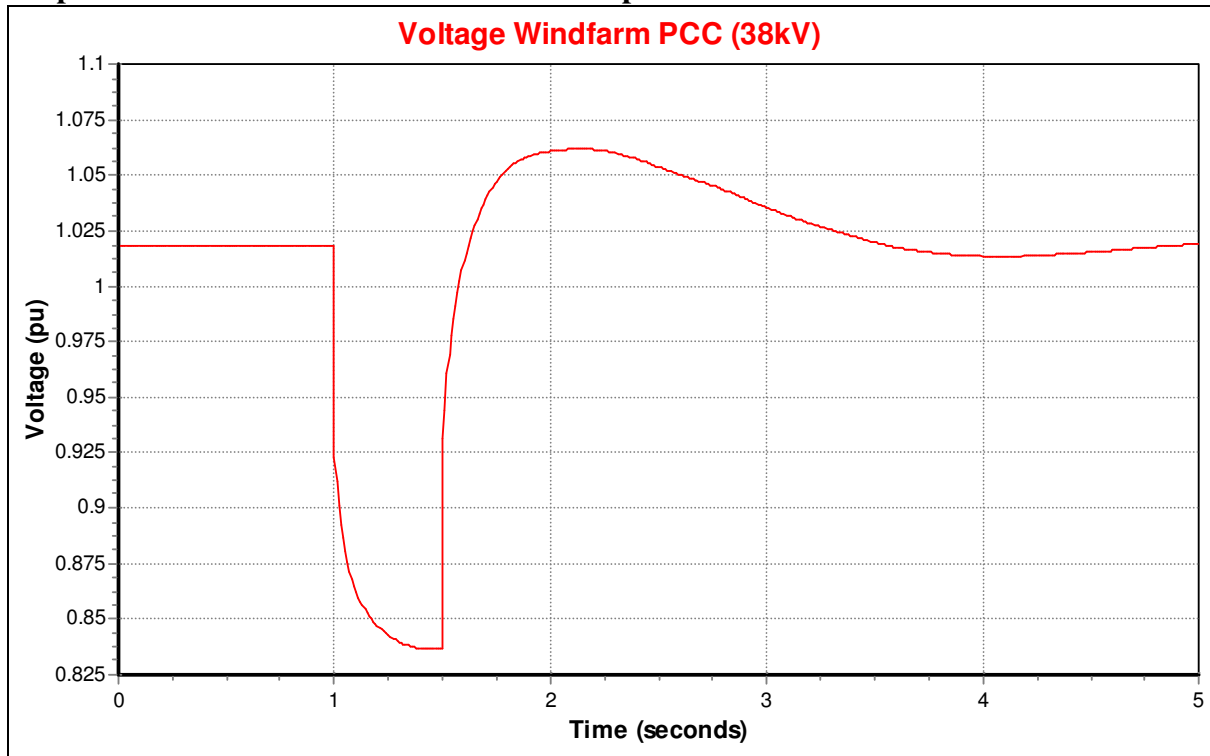

Fault Location: Substation F (Node 401)
Existing Windfarm Interface Protection Trip: Yes
Proposed Windfarm Interface Protection Trip: Yes

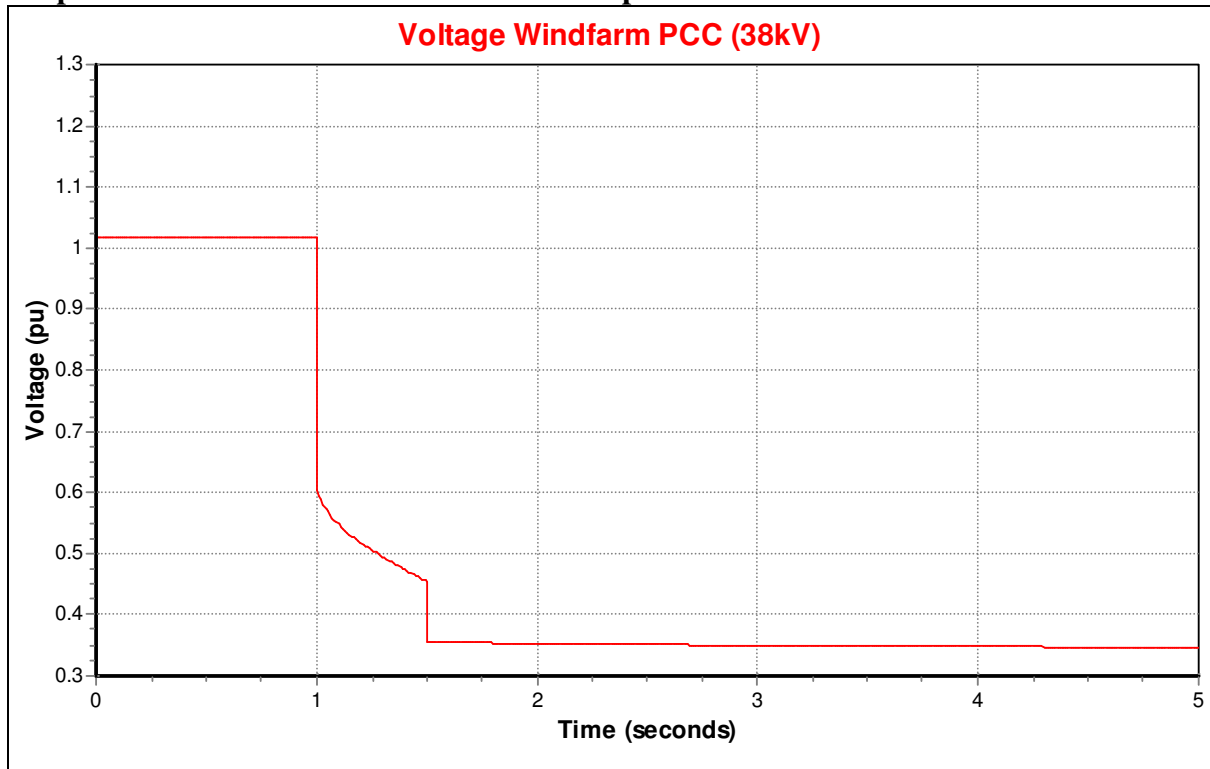

Details:

Fault Type: Three Phase Fault

Fault Duration: 500ms Duration

Results: Summer Night Valley

Wind Farm Output: 15%

Fault Location: Substation B (Node 601)

Existing Windfarm Interface Protection Trip: Yes

Proposed Windfarm Interface Protection Trip: No

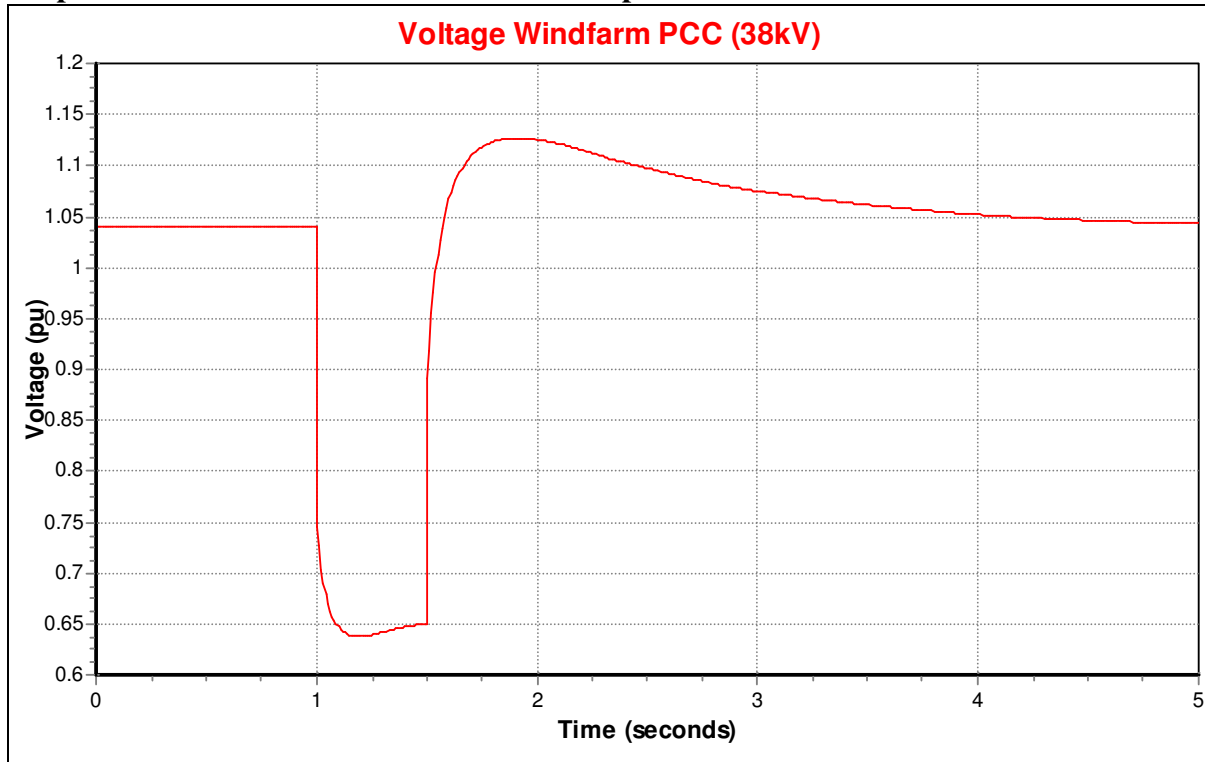

Fault Location: Substation C (Node 901)
Existing Windfarm Interface Protection Trip: Yes
Proposed Windfarm Interface Protection Trip: No

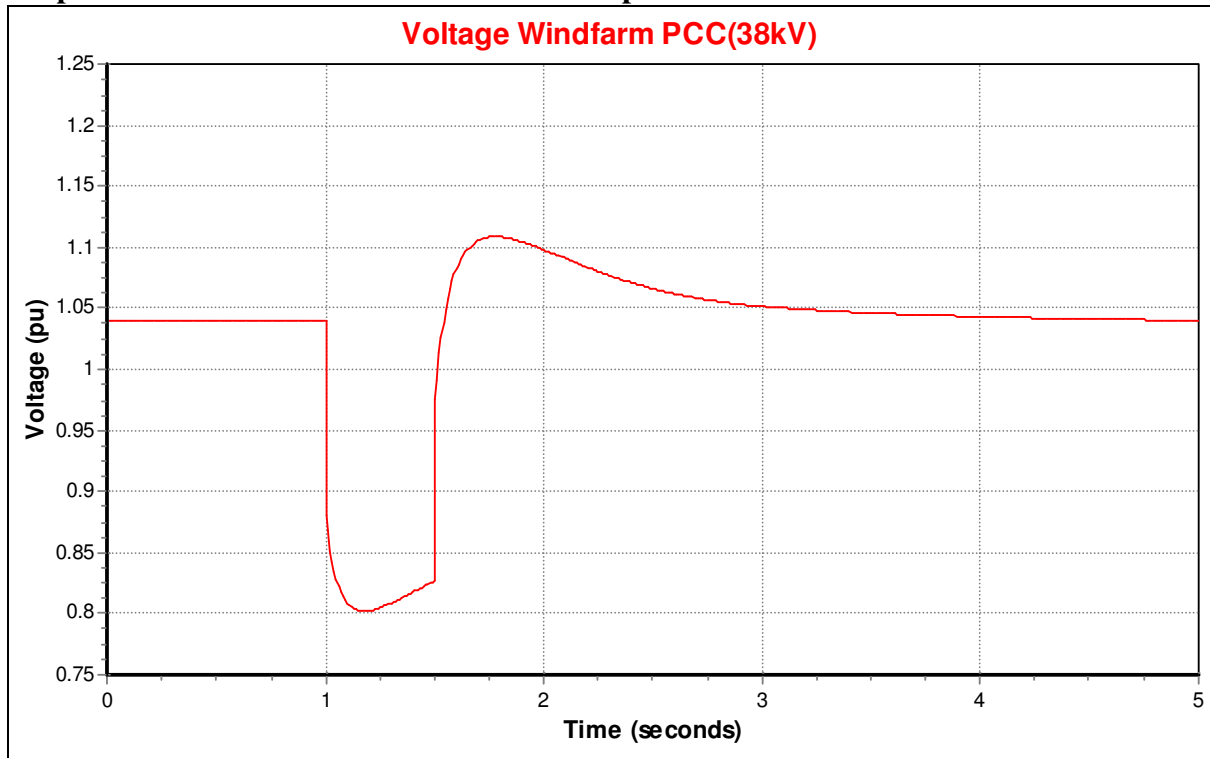

Fault Location: Substation D (Node 501)
Existing Windfarm Interface Protection Trip: Yes
Proposed Windfarm Interface Protection Trip: No

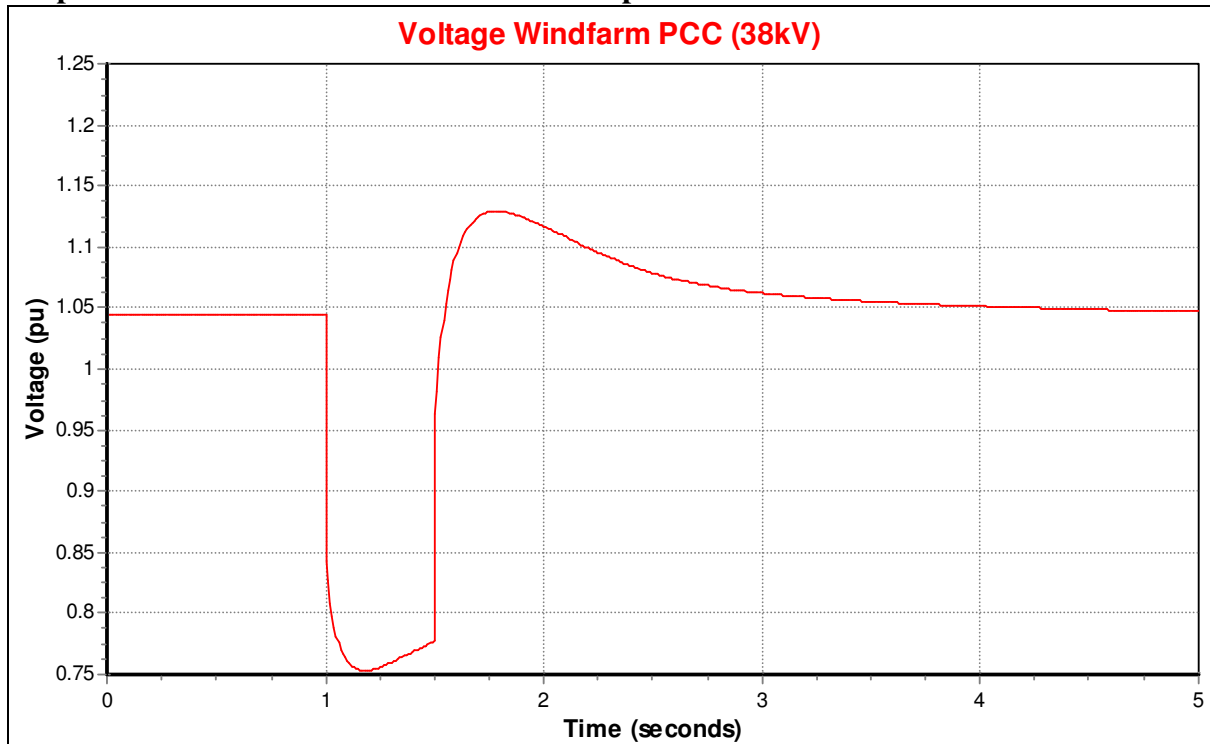

Fault Location: Substation E (Node 801)
Existing Windfarm Interface Protection Trip: Yes
Proposed Windfarm Interface Protection Trip: No

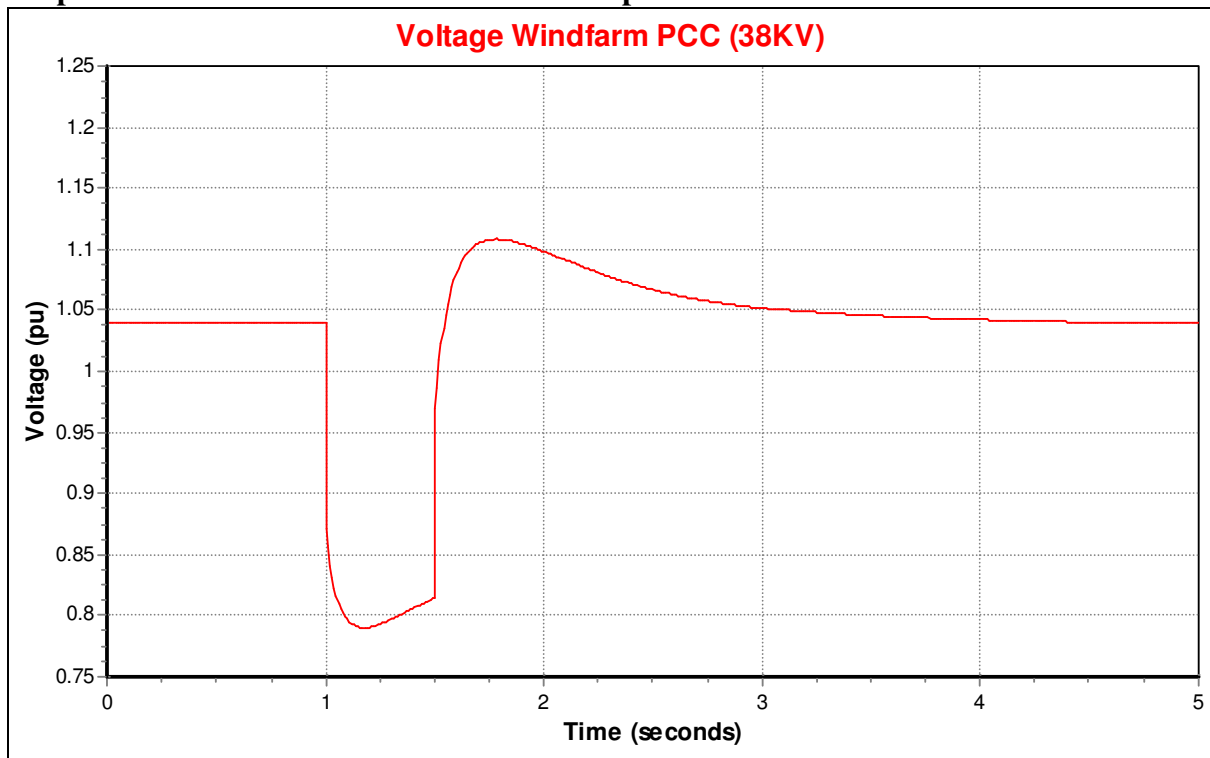

Fault Location: Substation F (Node 401)
Existing Windfarm Interface Protection Trip: Yes
Proposed Windfarm Interface Protection Trip: Yes

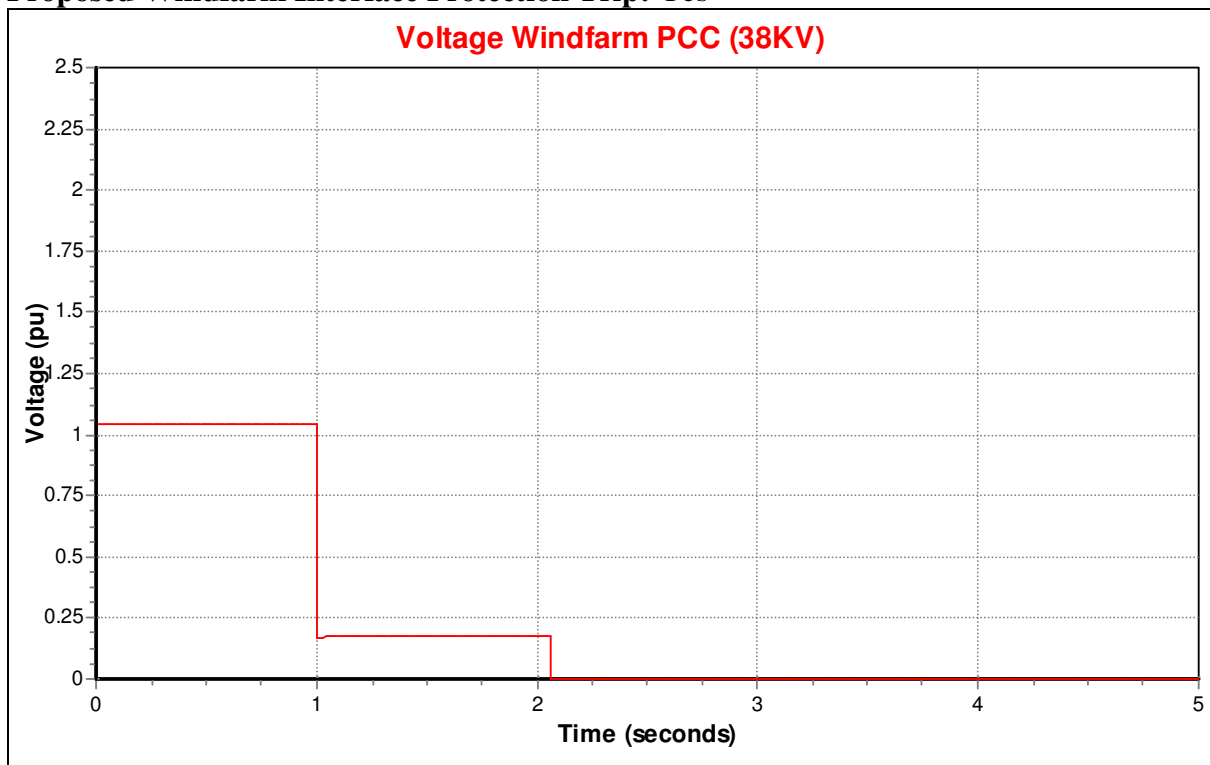

Details:

Fault Type: Three Phase Fault

Fault Duration: 500ms Duration

Results: Summer Night Valley

Wind Farm Output: 100%

Fault Location: Substation B (Node 601)

Existing Windfarm Interface Protection Trip: Yes

Proposed Windfarm Interface Protection Trip: Yes

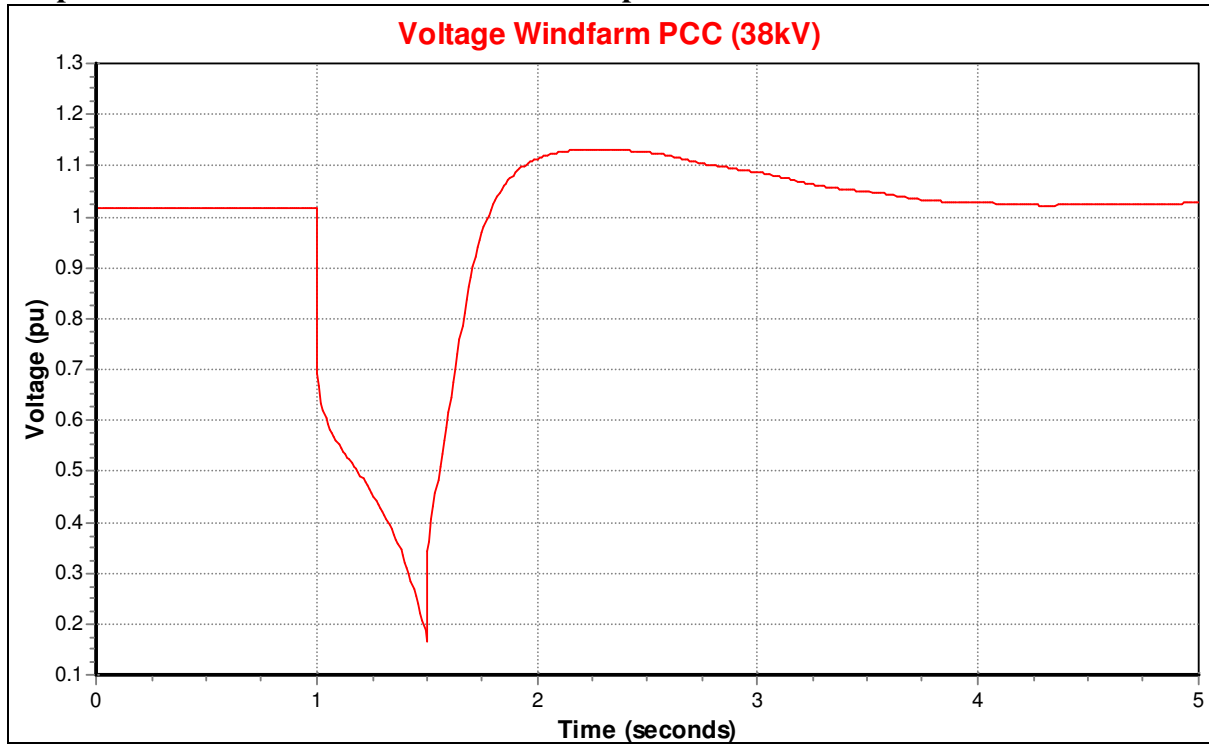

Fault Location: Substation C (Node 901)
Existing Windfarm Interface Protection Trip: No
Proposed Windfarm Interface Protection Trip: No

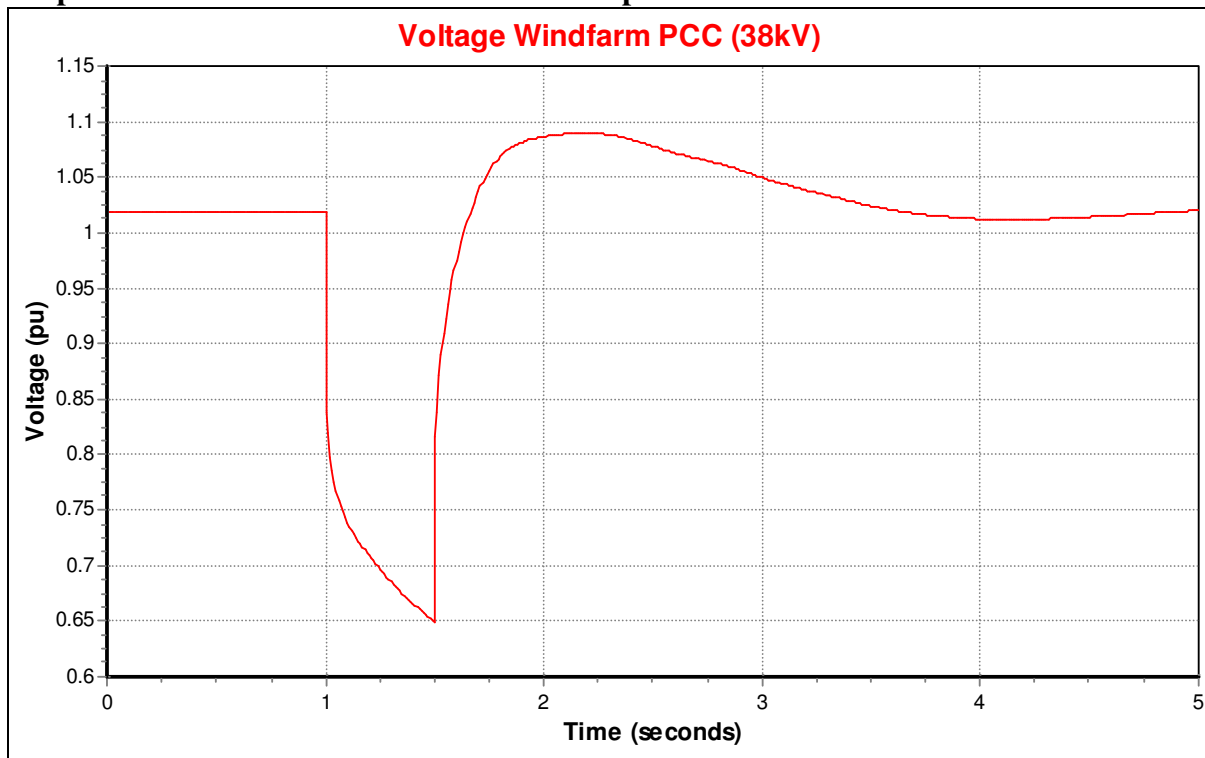

Fault Location: Substation D (Node 501)
Existing Windfarm Interface Protection Trip: Yes
Proposed Windfarm Interface Protection Trip: No

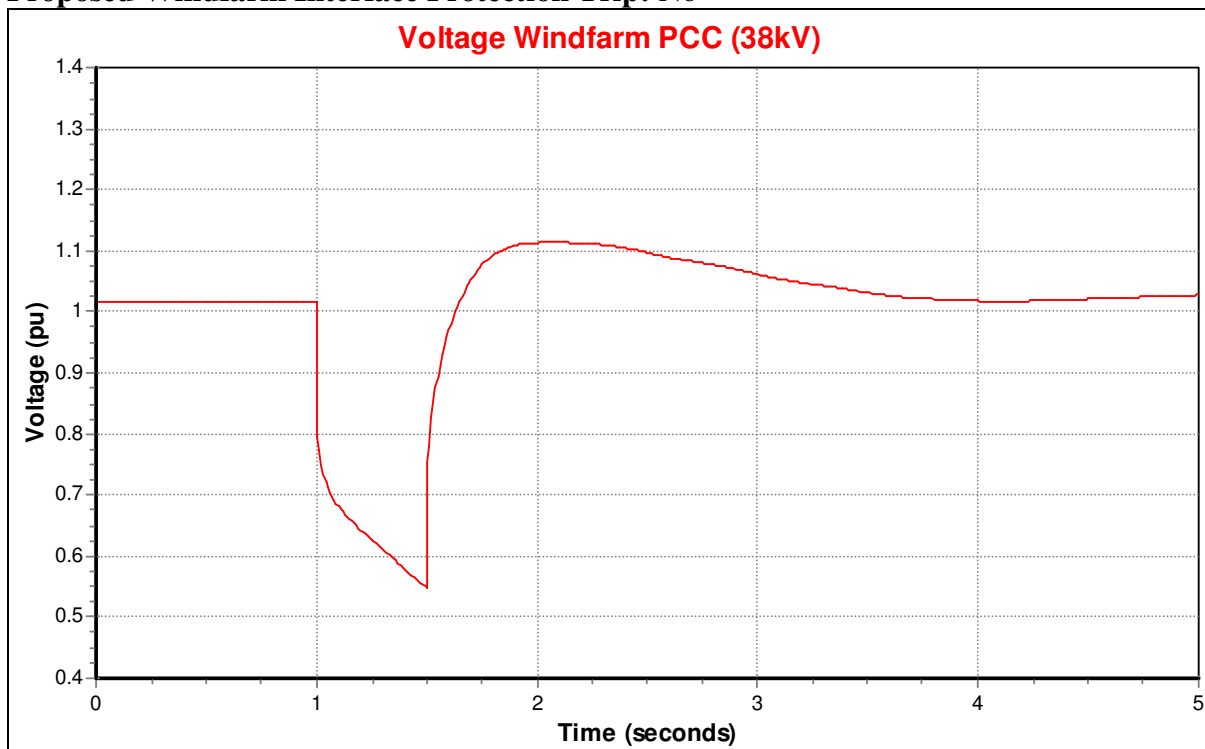

Fault Location: Substation E (Node 801)
Existing Windfarm Interface Protection Trip: No
Proposed Windfarm Interface Protection Trip: No

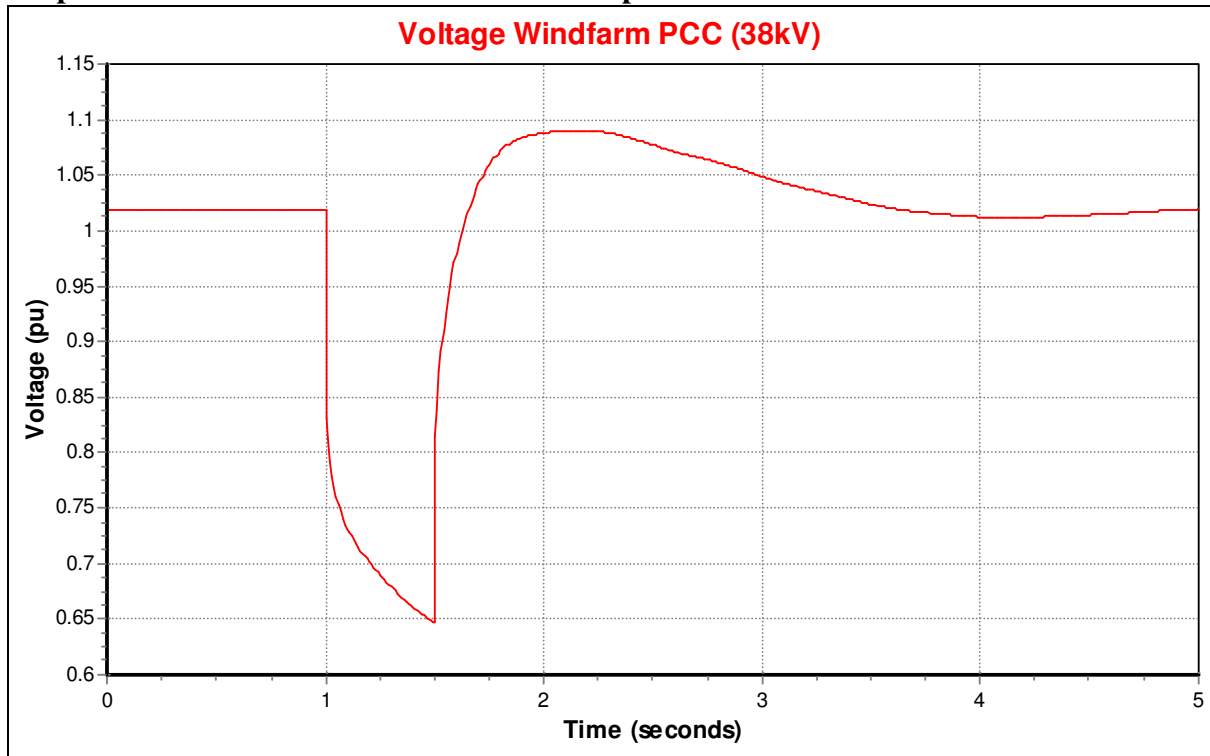

Fault Location: Substation F (Node 401)
Existing Windfarm Interface Protection Trip: Yes
Proposed Windfarm Interface Protection Trip: Yes

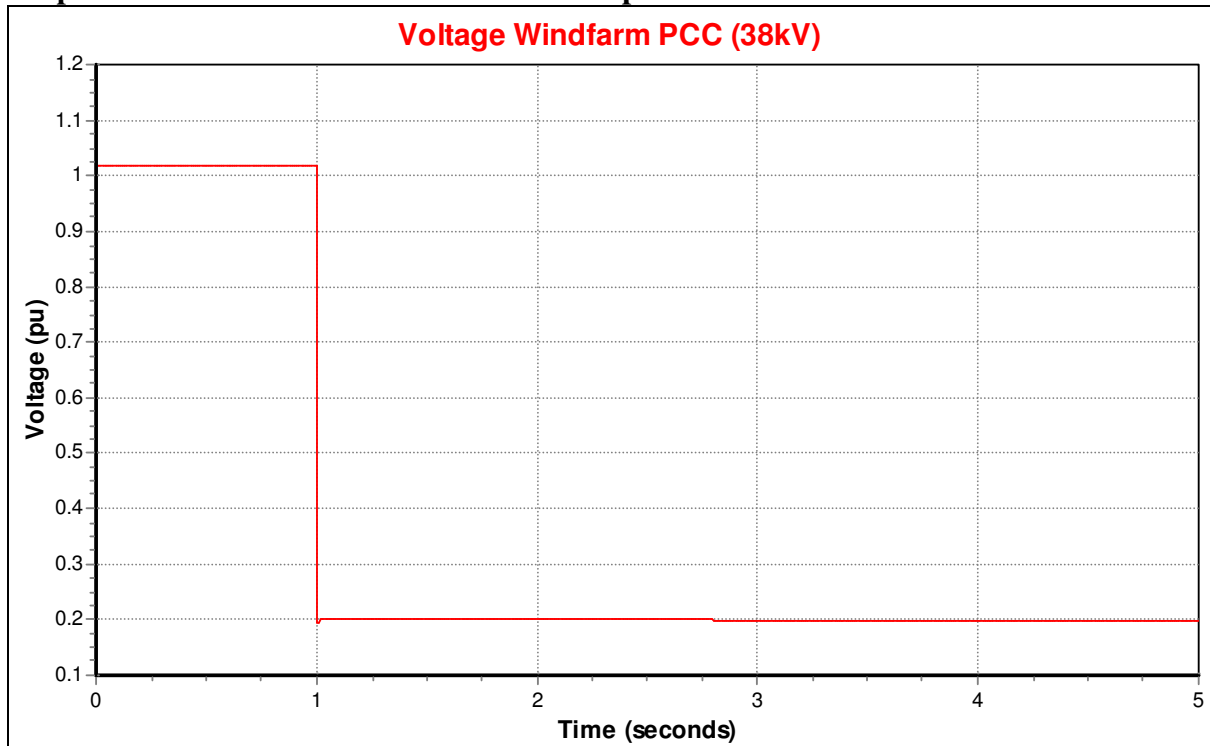

Details:

Fault Type: Line to Line Fault

Fault Duration: 500ms Duration

Results: Winter Peak

Wind Farm Output: 15%

Fault Location: Substation B (Node 601)

Existing Windfarm Interface Protection Trip: No

Proposed Windfarm Interface Protection Trip: No

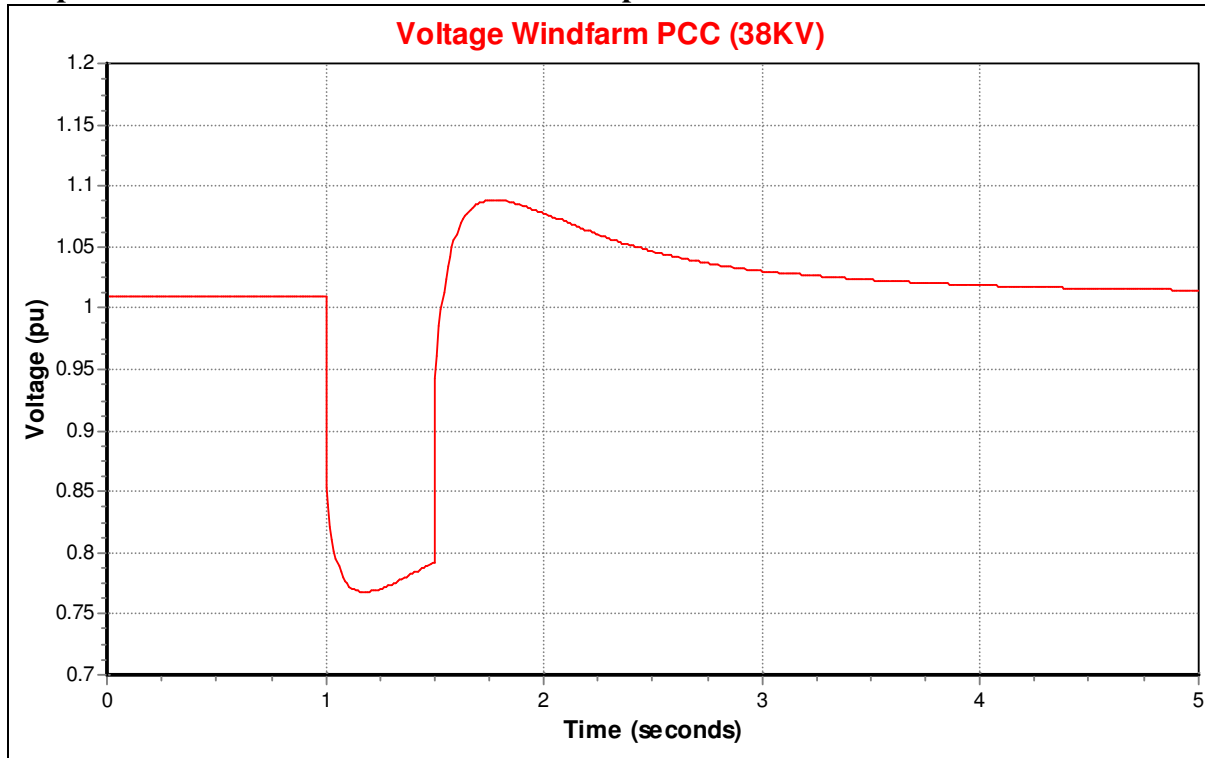

Fault Location: Substation C (Node 901)
Existing Windfarm Interface Protection Trip: No
Proposed Windfarm Interface Protection Trip: No

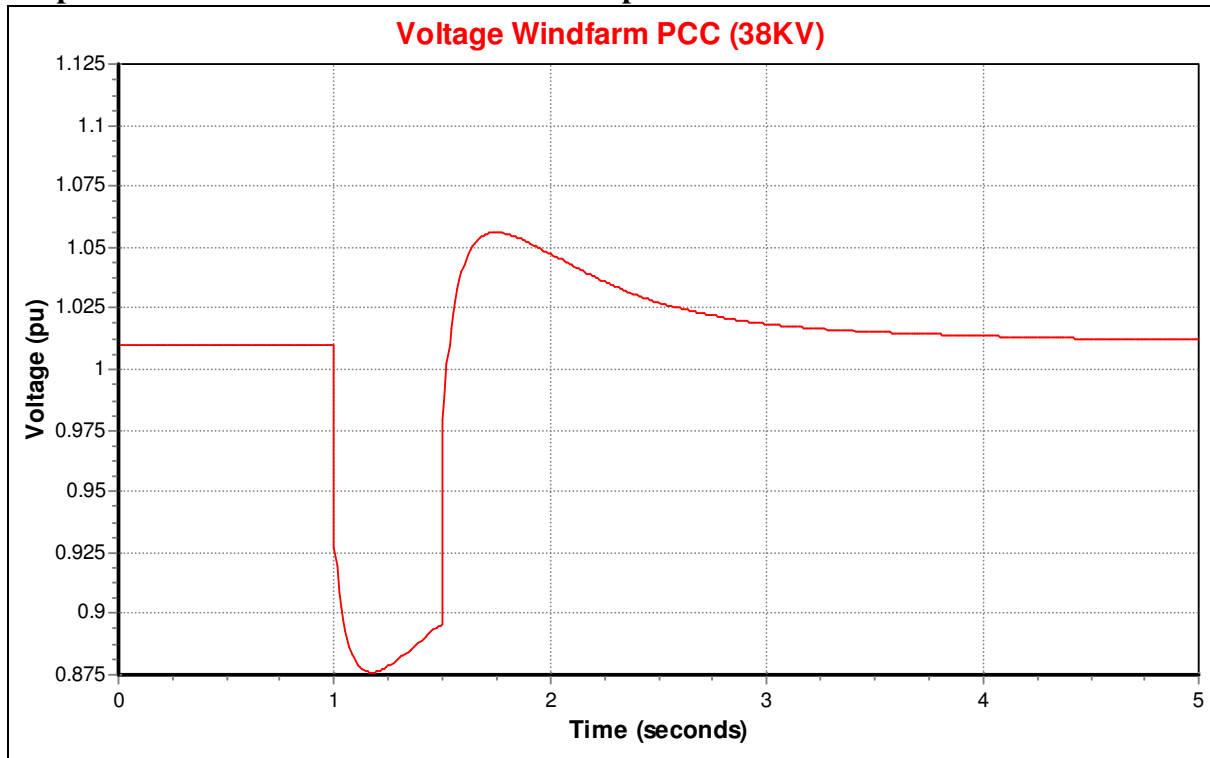

Fault Location: Substation D (Node 501)
Existing Windfarm Interface Protection Trip: No
Proposed Windfarm Interface Protection Trip: No

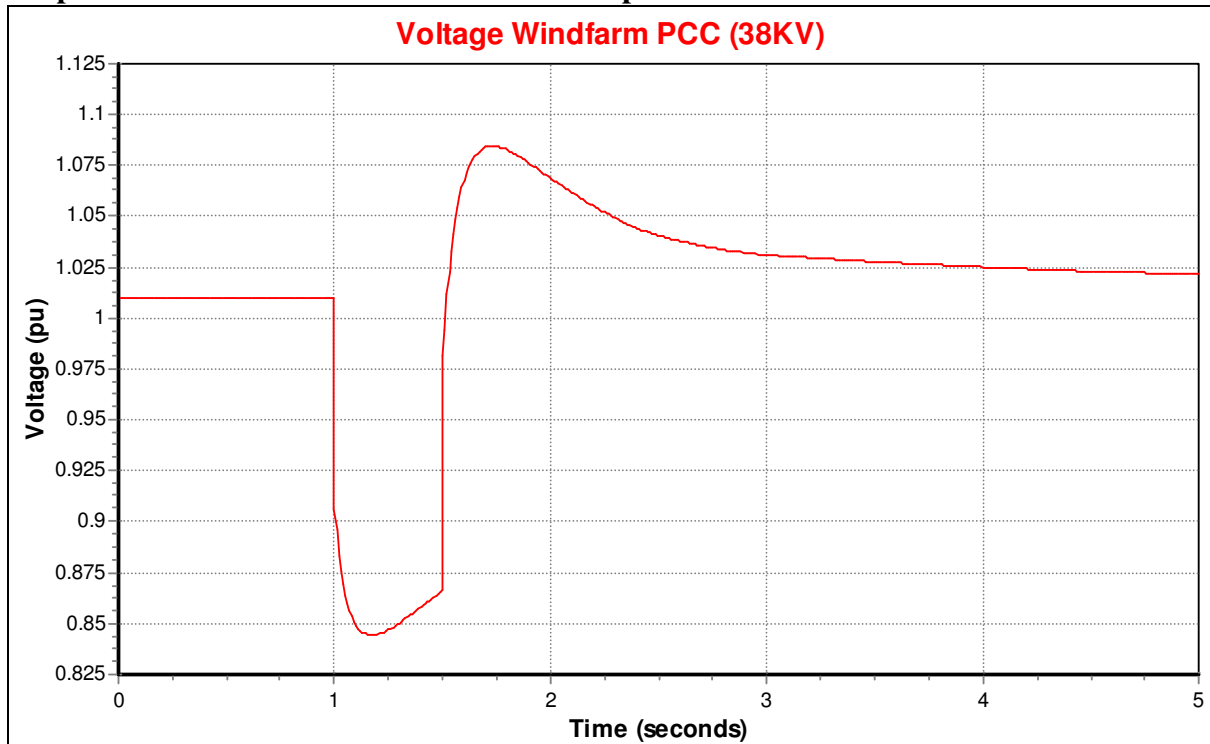

Fault Location: Substation E (Node 801)
Existing Windfarm Interface Protection Trip: No
Proposed Windfarm Interface Protection Trip: No

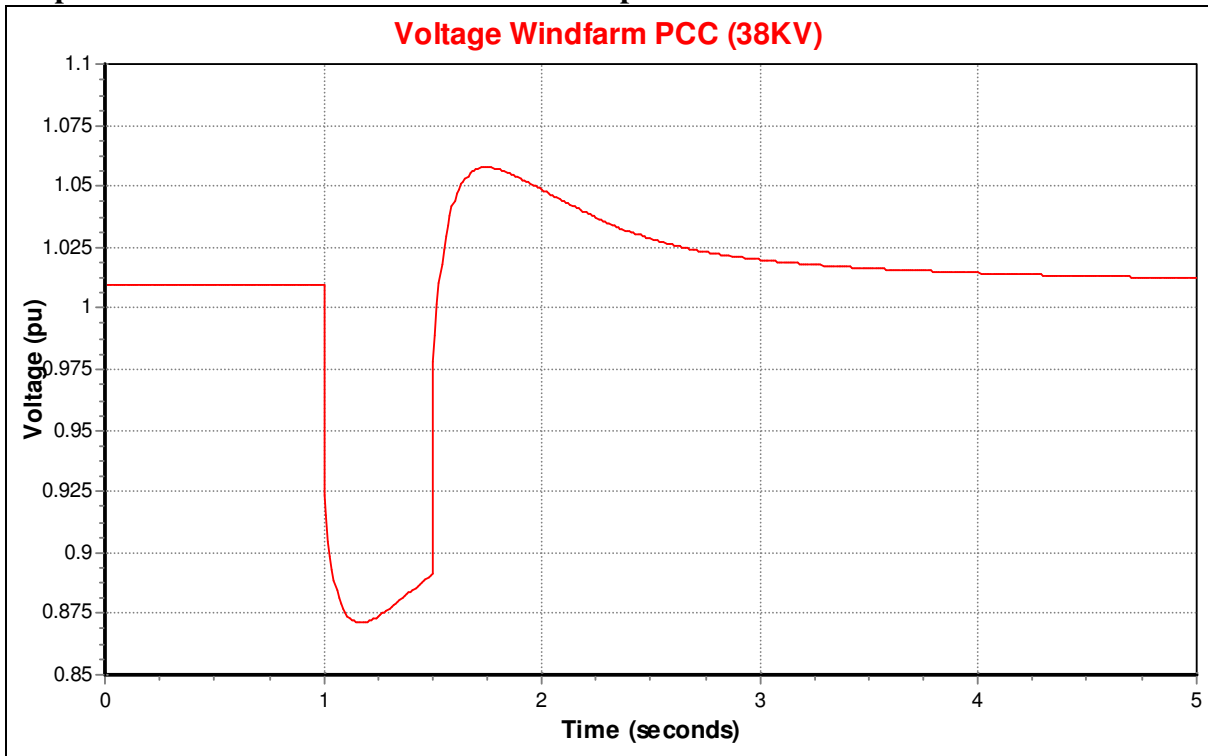

Fault Location: Substation F (Node 401)
Existing Windfarm Interface Protection Trip: Yes
Proposed Windfarm Interface Protection Trip: Yes

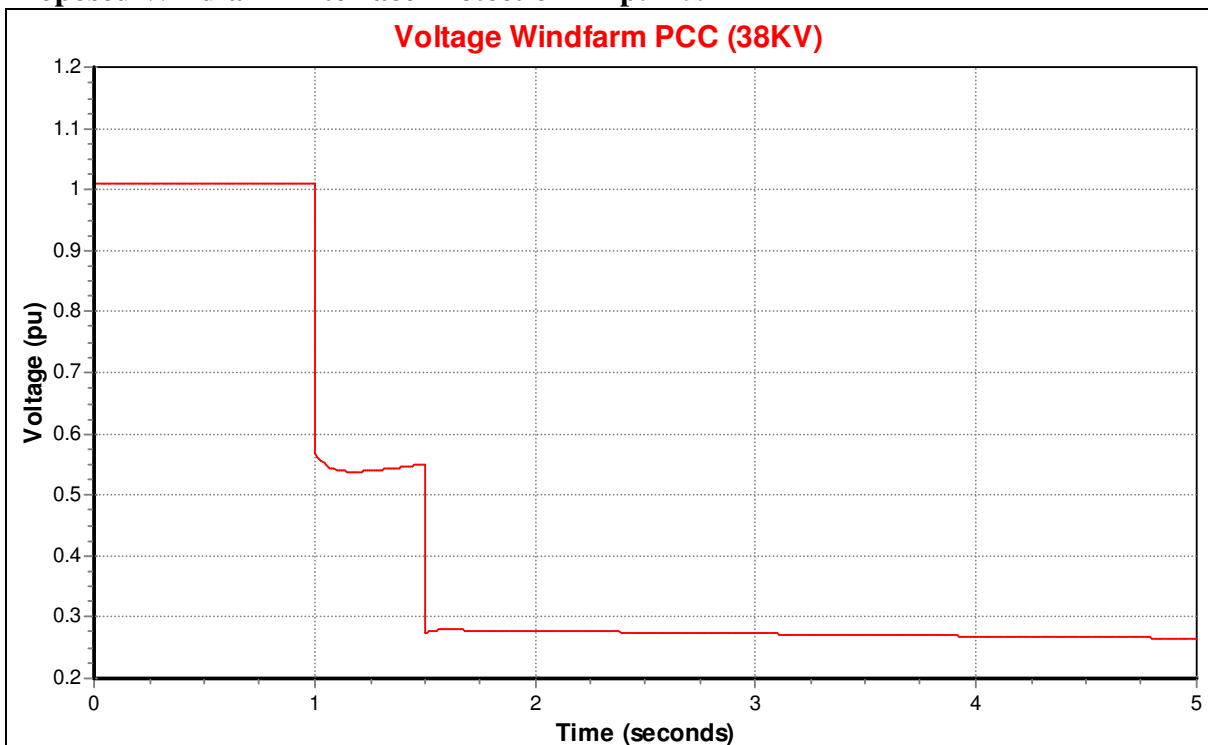

Details:

Fault Type: Line to Line Fault

Fault Duration: 500ms Duration

Results: Winter Peak

Wind Farm Output: 100%

Fault Location: Substation B (Node 601)

Existing Windfarm Interface Protection Trip: Yes

Proposed Windfarm Interface Protection Trip: No

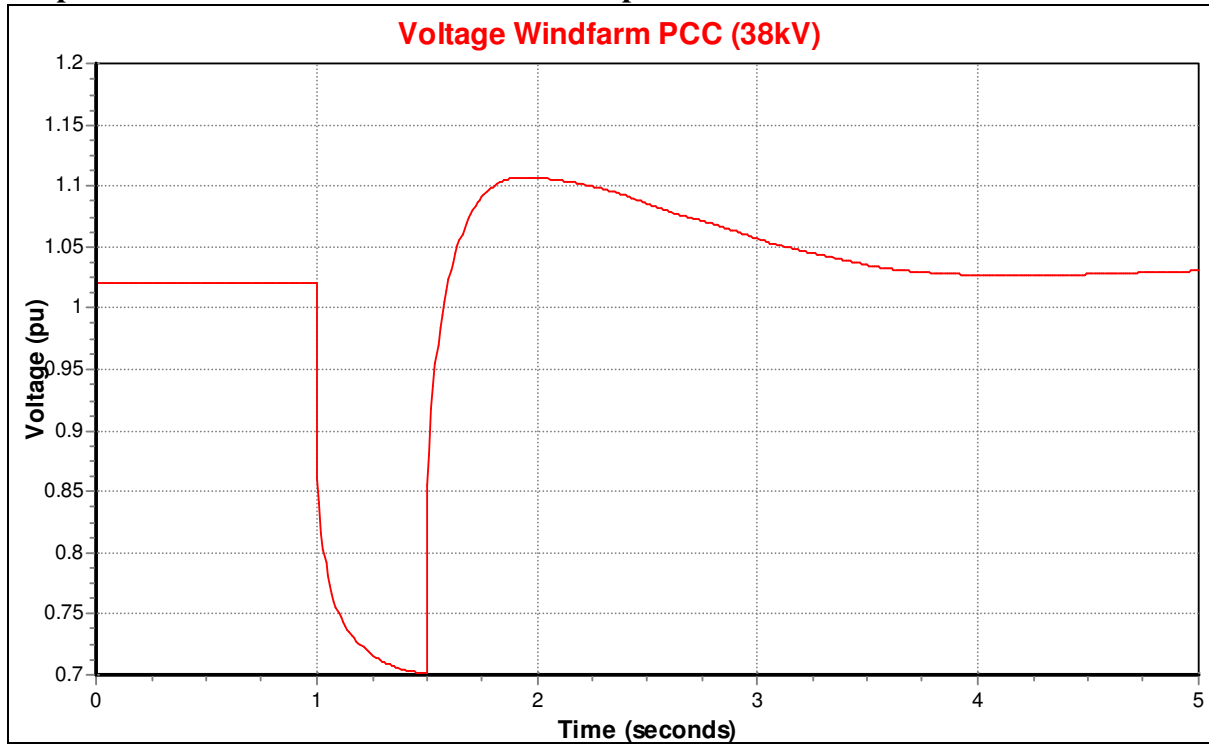

Fault Location: Substation C (Node 901)
Existing Windfarm Interface Protection Trip: No
Proposed Windfarm Interface Protection Trip: No

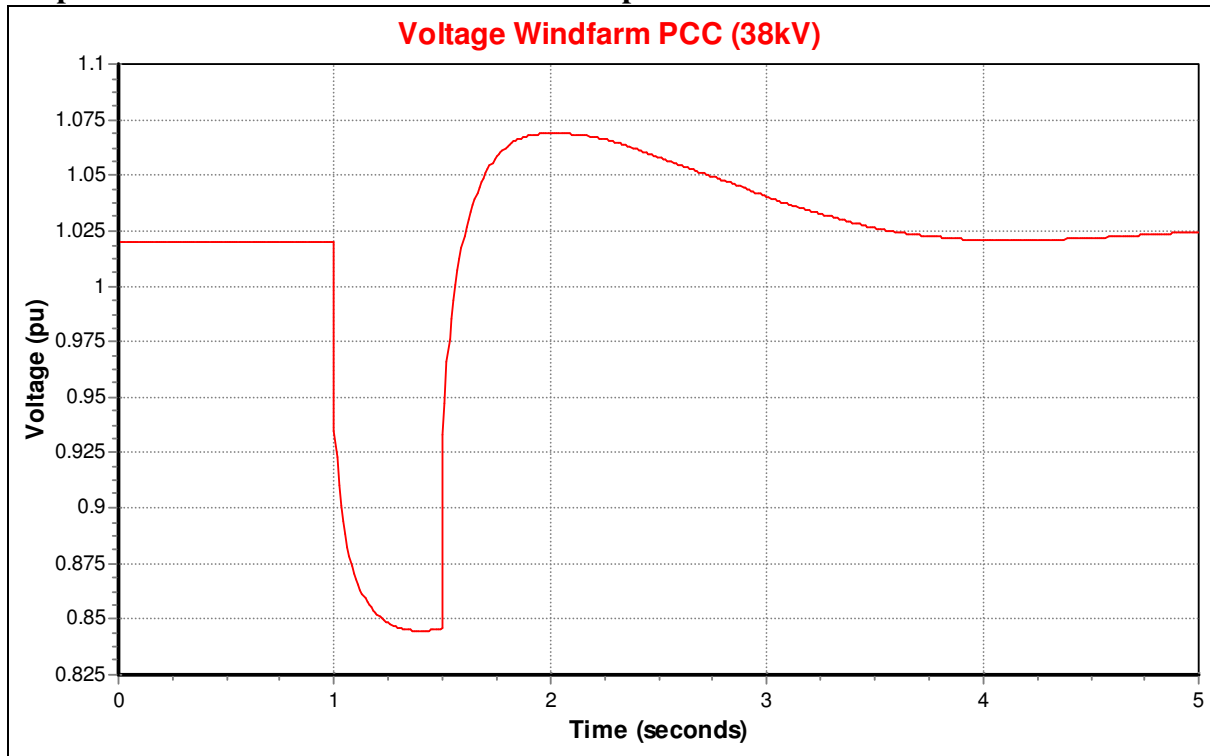

Fault Location: Substation D (Node 501)
Existing Windfarm Interface Protection Trip: Yes
Proposed Windfarm Interface Protection Trip: No

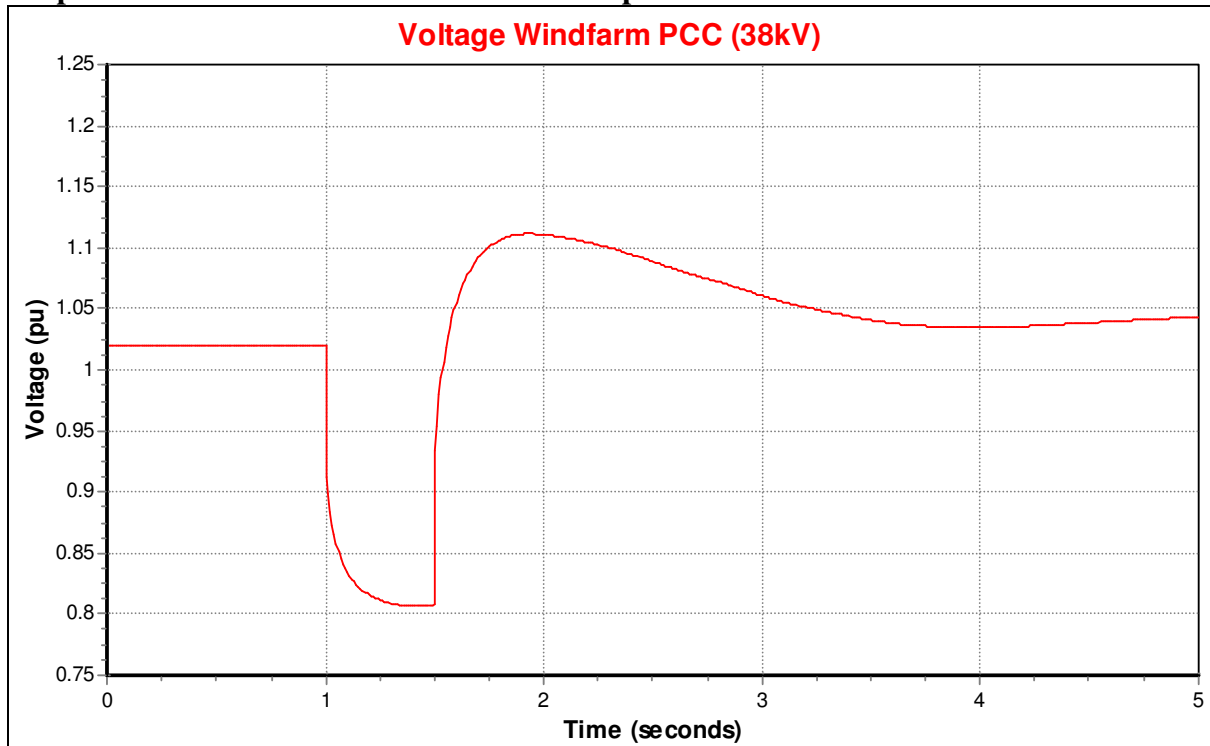

Fault Location: Substation E (Node 801)
Existing Windfarm Interface Protection Trip: No
Proposed Windfarm Interface Protection Trip: No

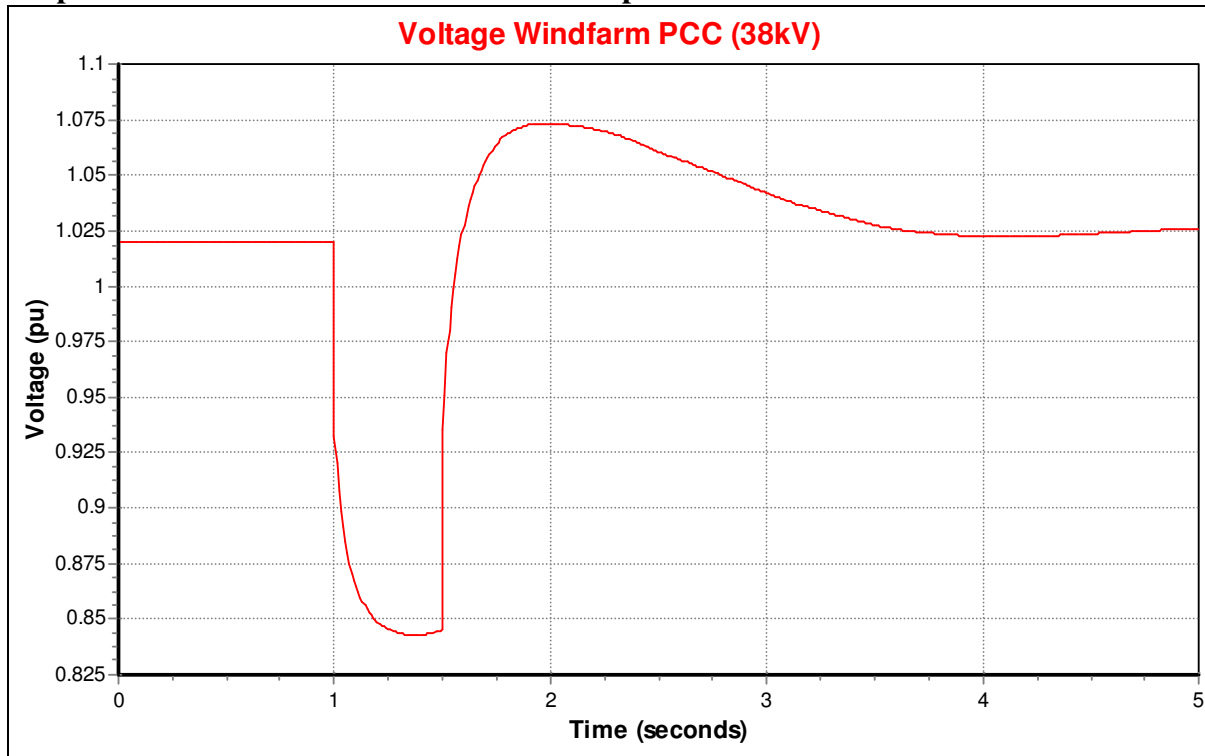

Fault Location: Substation F (Node 401)
Existing Windfarm Interface Protection Trip: Yes
Proposed Windfarm Interface Protection Trip: Yes

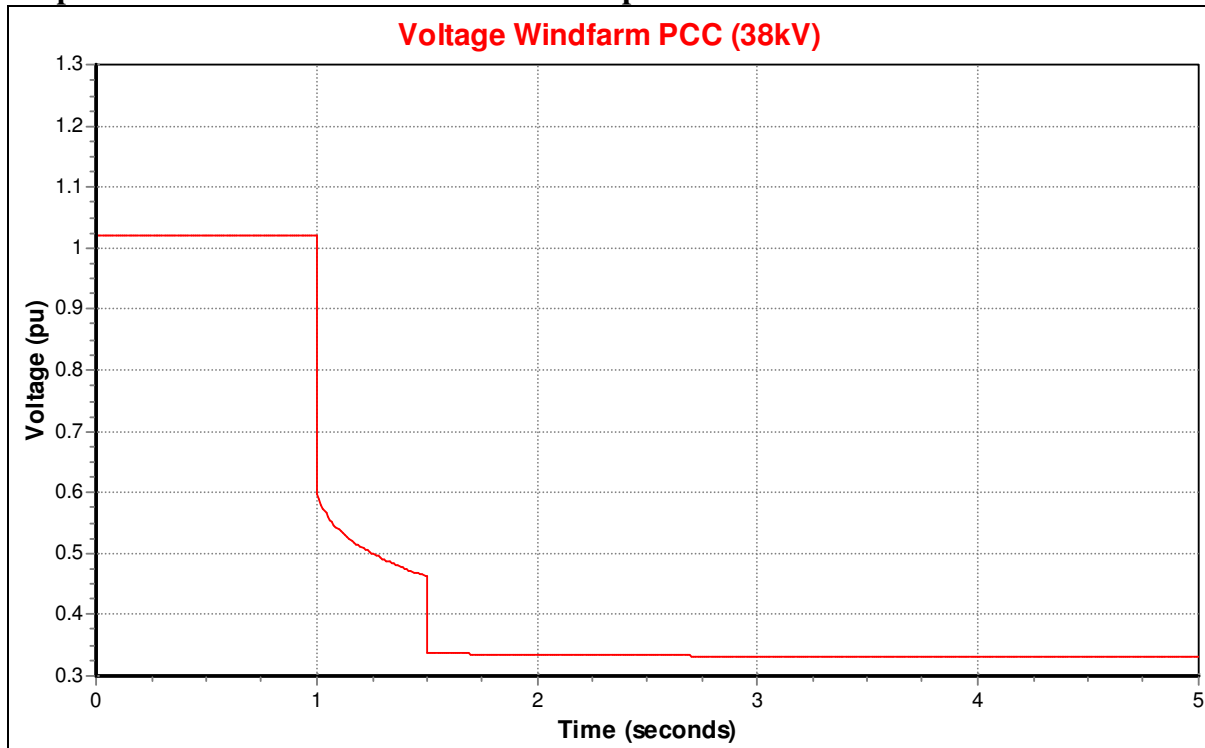

Details:

Fault Type: Three Phase Fault

Fault Duration: 500ms Duration

Results: Winter Peak

Wind Farm Output: 15%

Fault Location: Substation B (Node 601)

Existing Windfarm Interface Protection Trip: No

Proposed Windfarm Interface Protection Trip: No

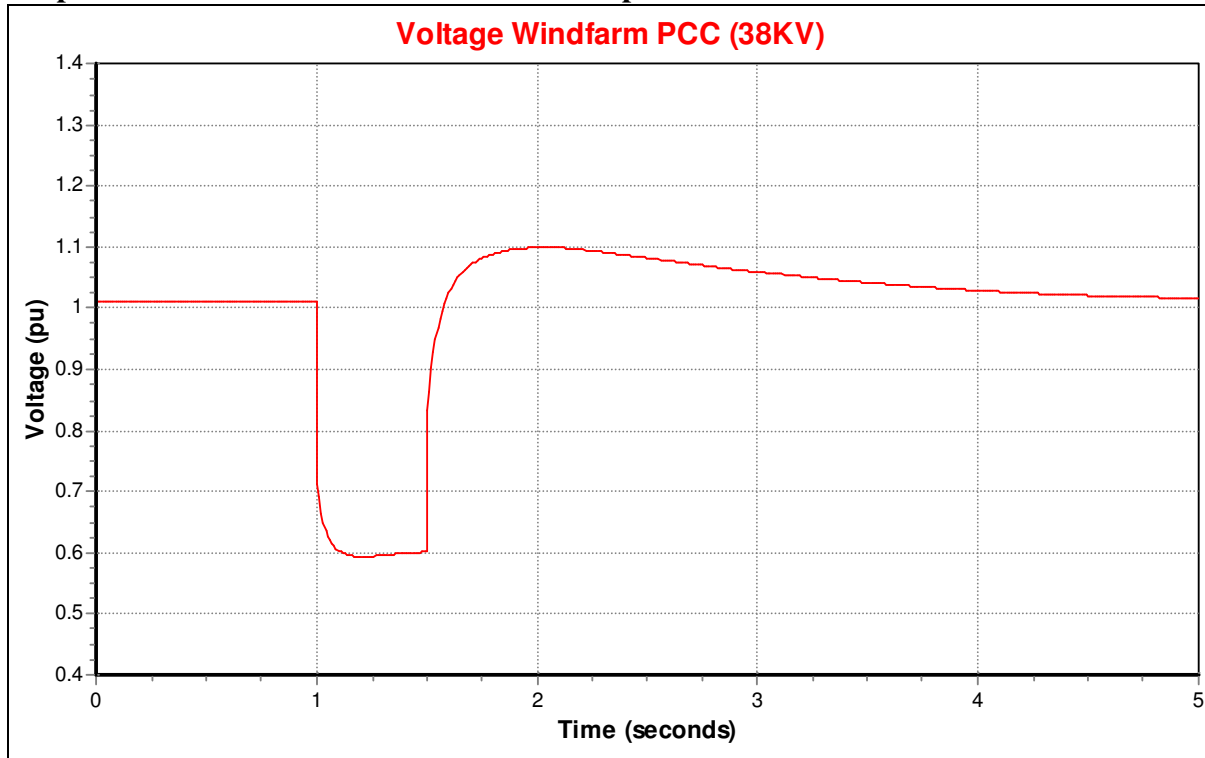

Fault Location: Substation C (Node 901)
Existing Windfarm Interface Protection Trip: No
Proposed Windfarm Interface Protection Trip: No

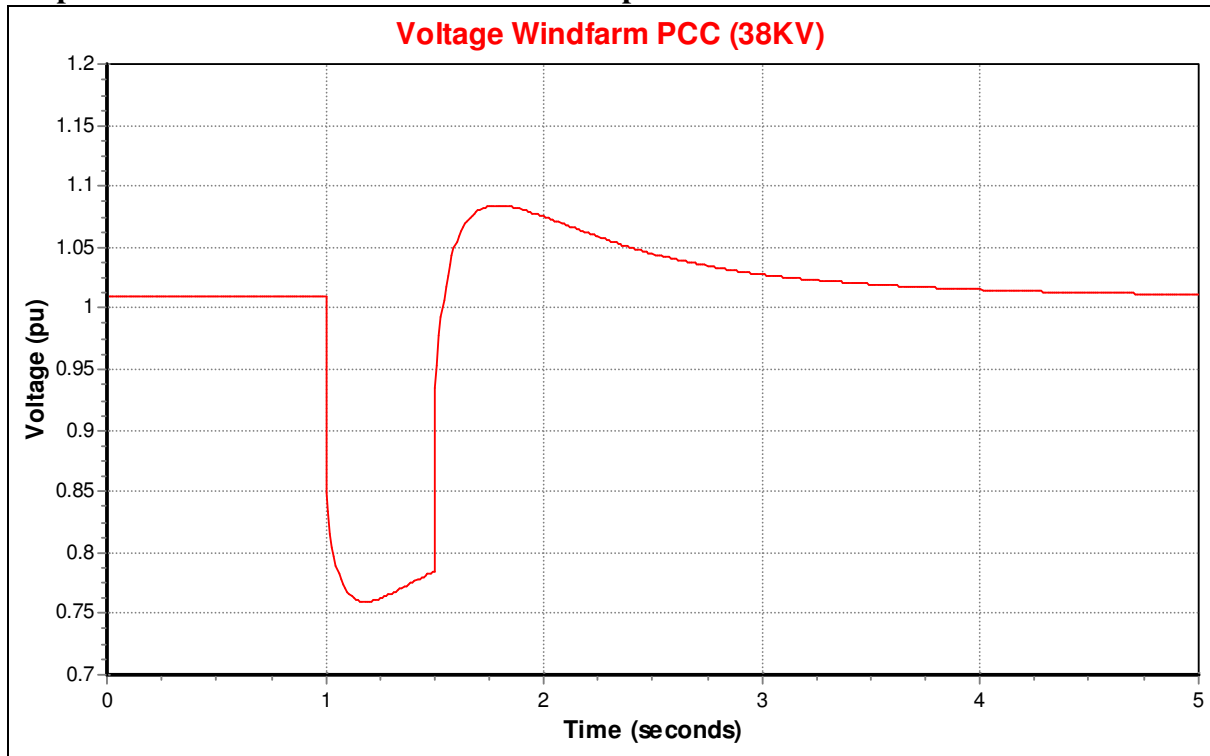

Fault Location: Substation D (Node 501)
Existing Windfarm Interface Protection Trip: Yes
Proposed Windfarm Interface Protection Trip: No

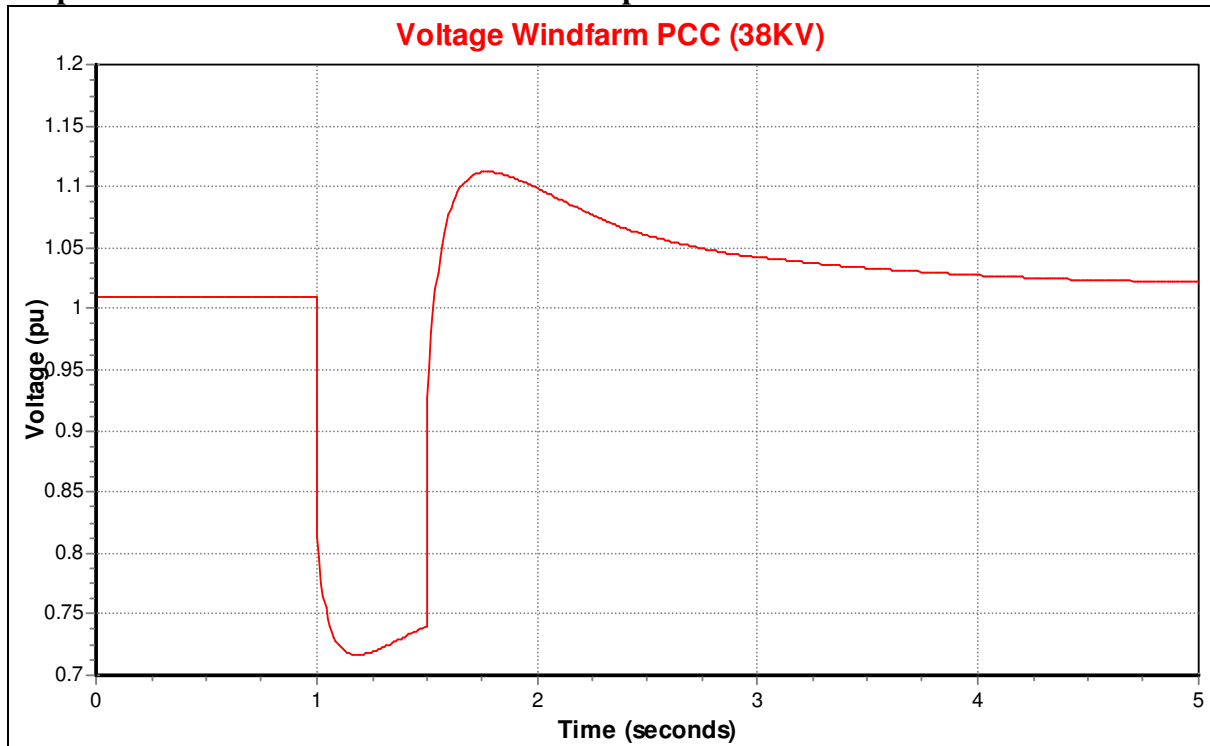

Fault Location: Substation E (Node 801)
Existing Windfarm Interface Protection Trip: No
Proposed Windfarm Interface Protection Trip: No

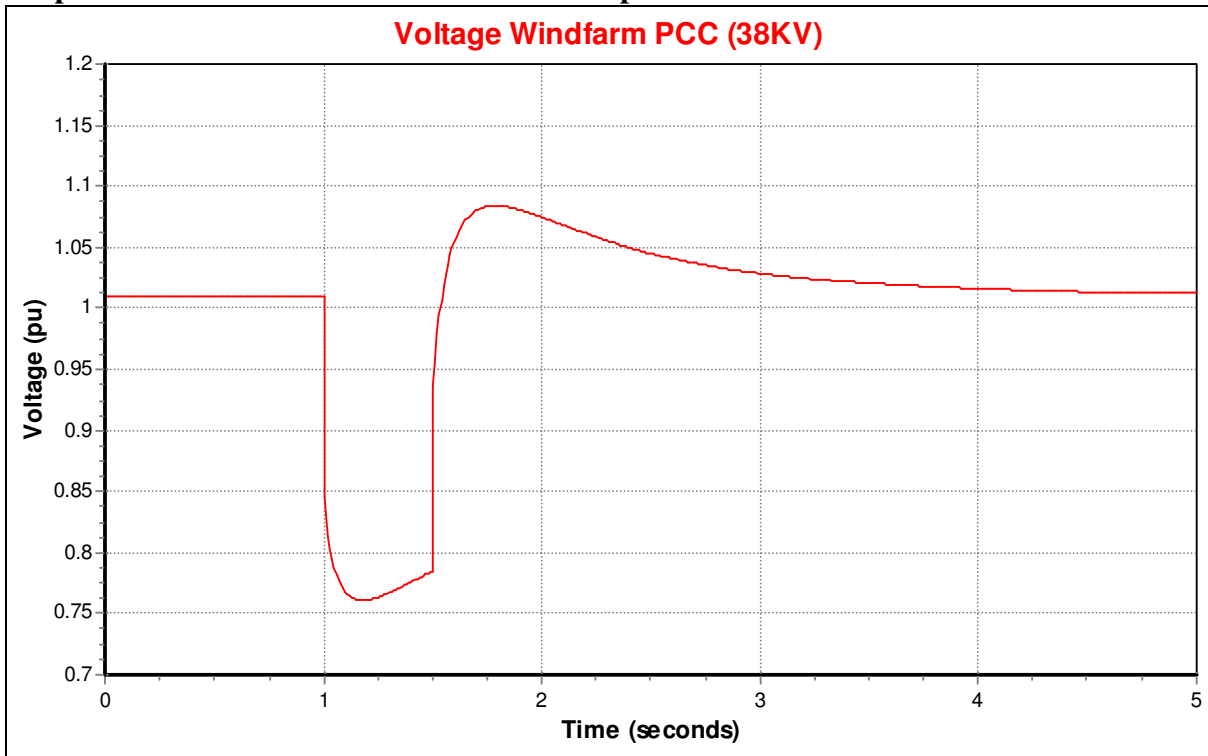

Fault Location: Substation F (Node 401)
Existing Windfarm Interface Protection Trip: Yes
Proposed Windfarm Interface Protection Trip: Yes

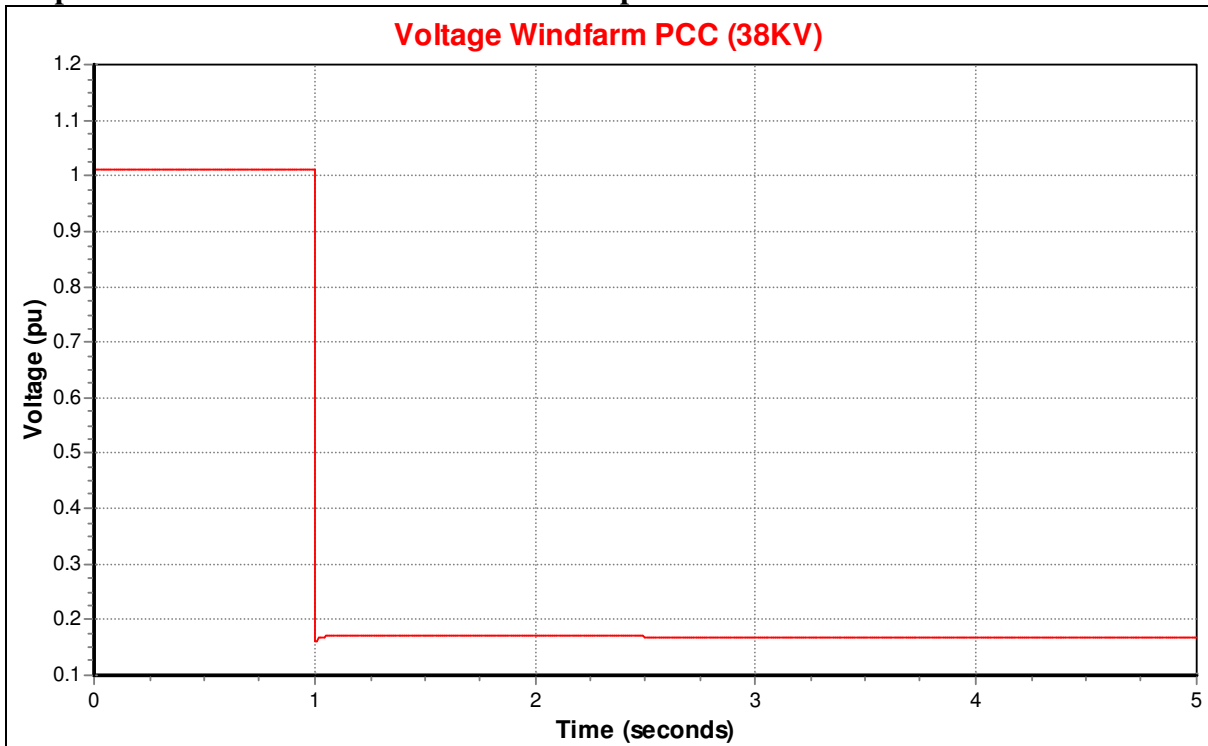

Details:

Fault Type: Three Phase Fault

Fault Duration: 500ms Duration

Results: Winter Peak

Wind Farm Output: 100%

Fault Location: Substation B (Node 601)

Existing Windfarm Interface Protection Trip: Yes

Proposed Windfarm Interface Protection Trip: No

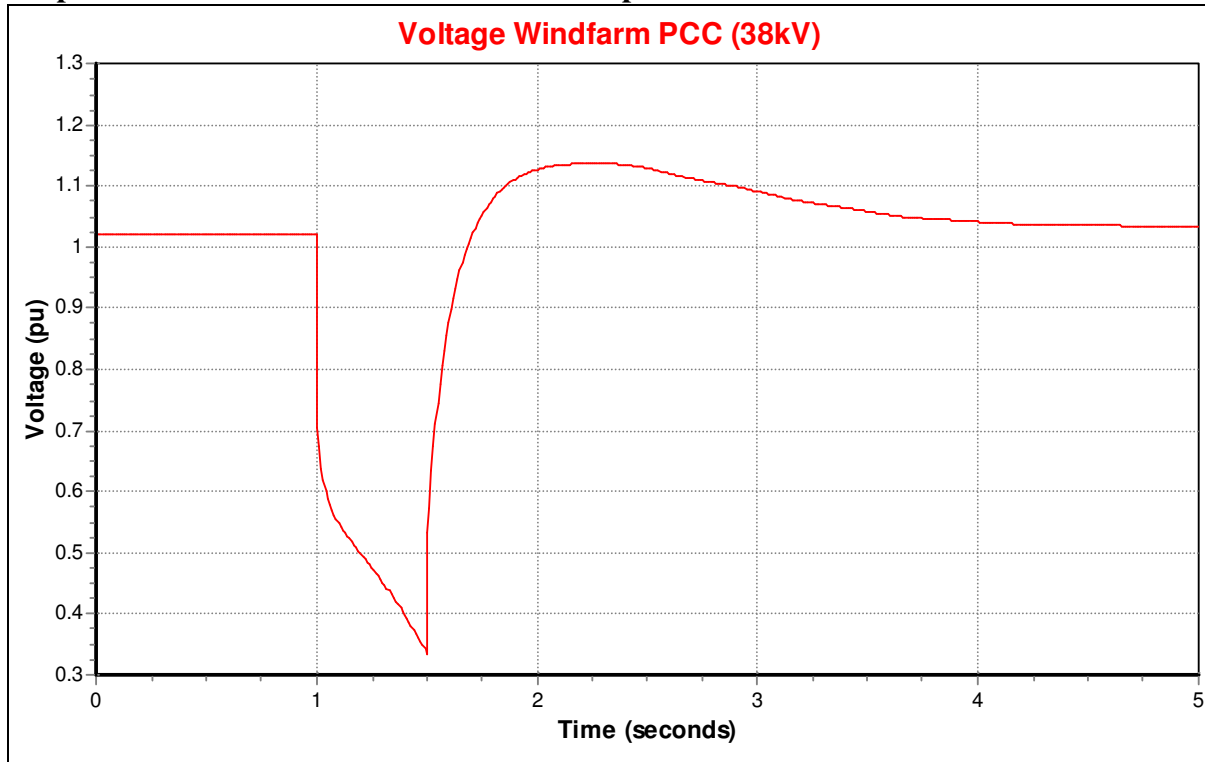

Fault Location: Substation C (Node 901)
Existing Windfarm Interface Protection Trip: No
Proposed Windfarm Interface Protection Trip: No

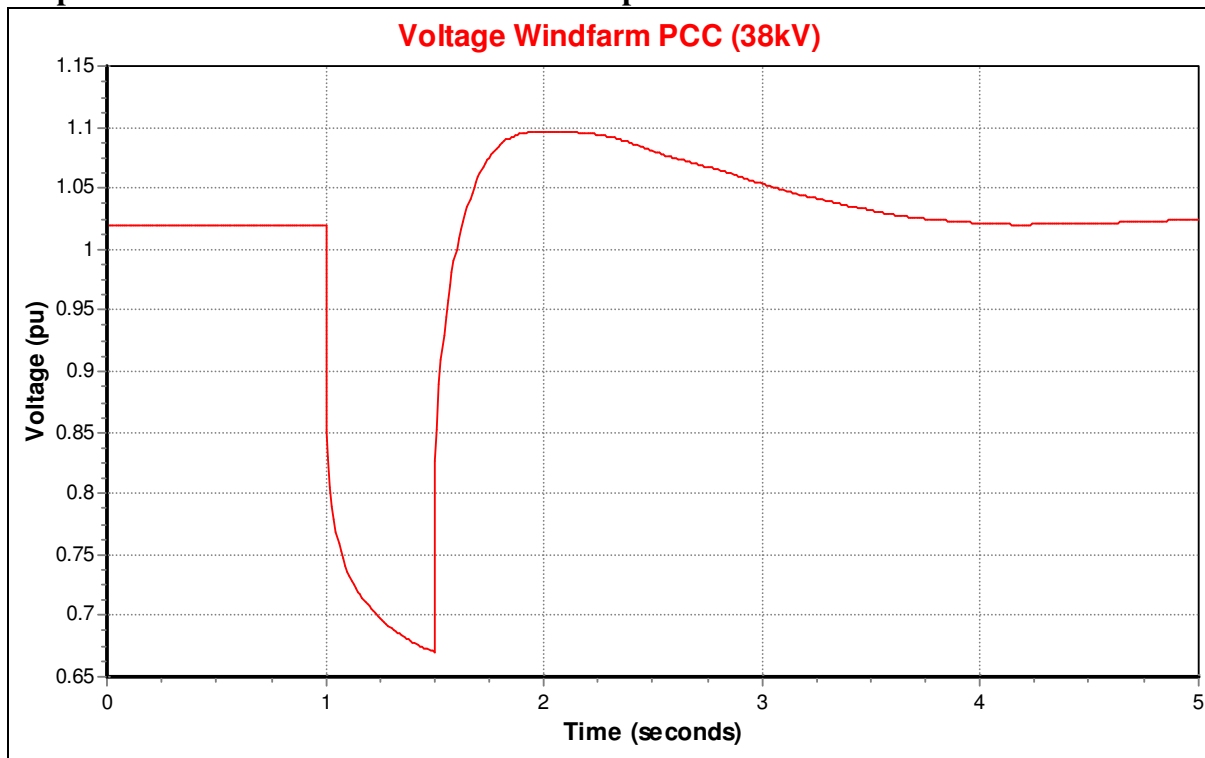

Fault Location: Substation D (Node 501)
Existing Windfarm Interface Protection Trip: Yes
Proposed Windfarm Interface Protection Trip: Yes

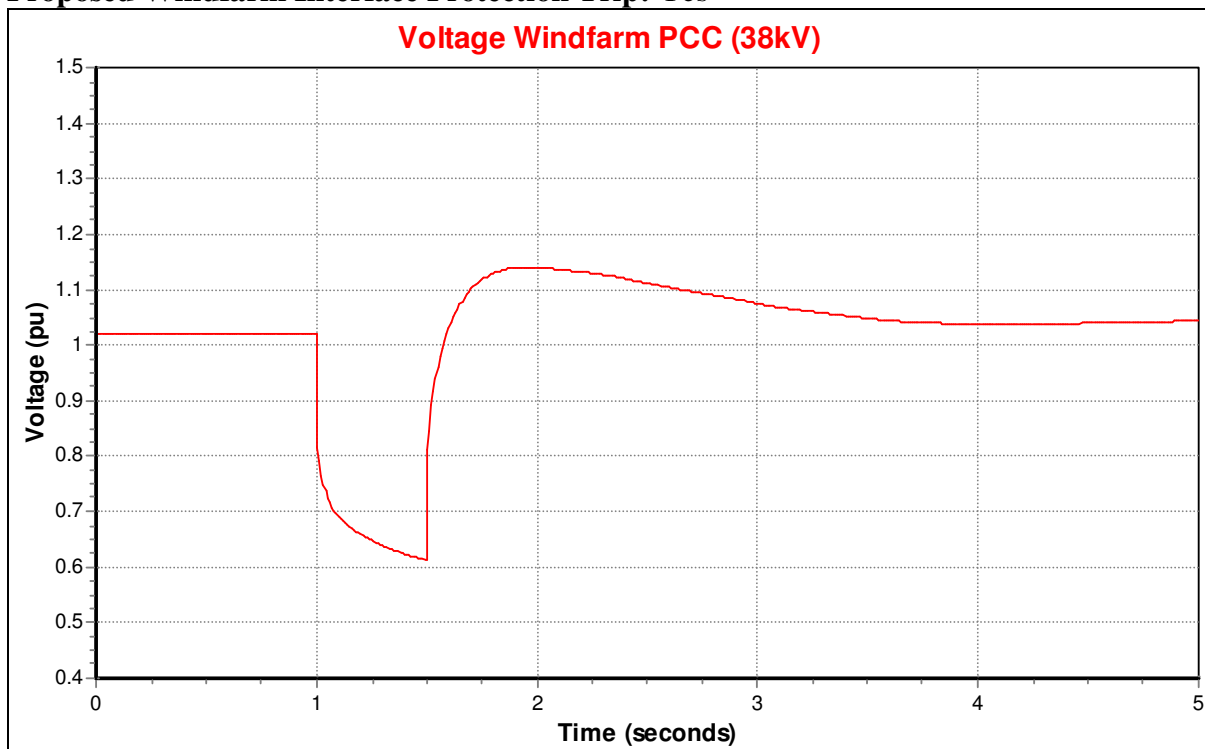

Fault Location: Substation E (Node 801)
Existing Windfarm Interface Protection Trip: No
Proposed Windfarm Interface Protection Trip: No

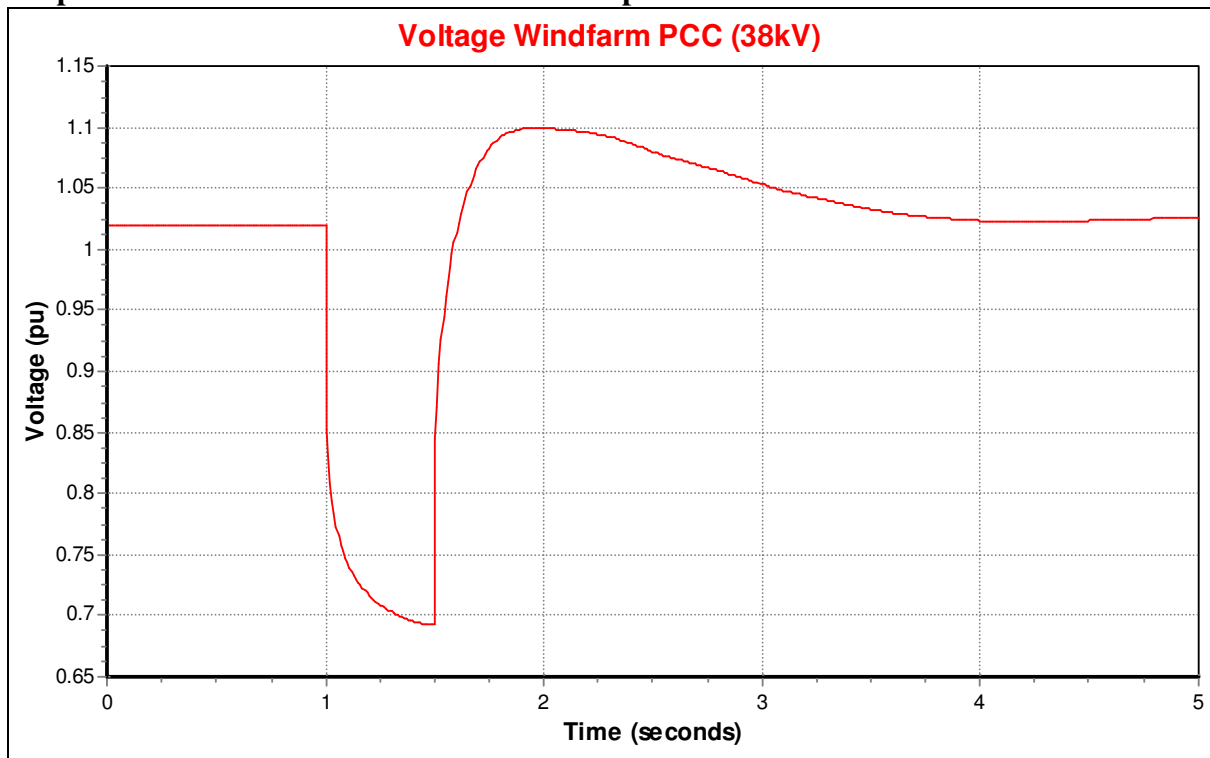

Fault Location: Substation F (Node 401)
Existing Windfarm Interface Protection Trip: Yes
Proposed Windfarm Interface Protection Trip: Yes

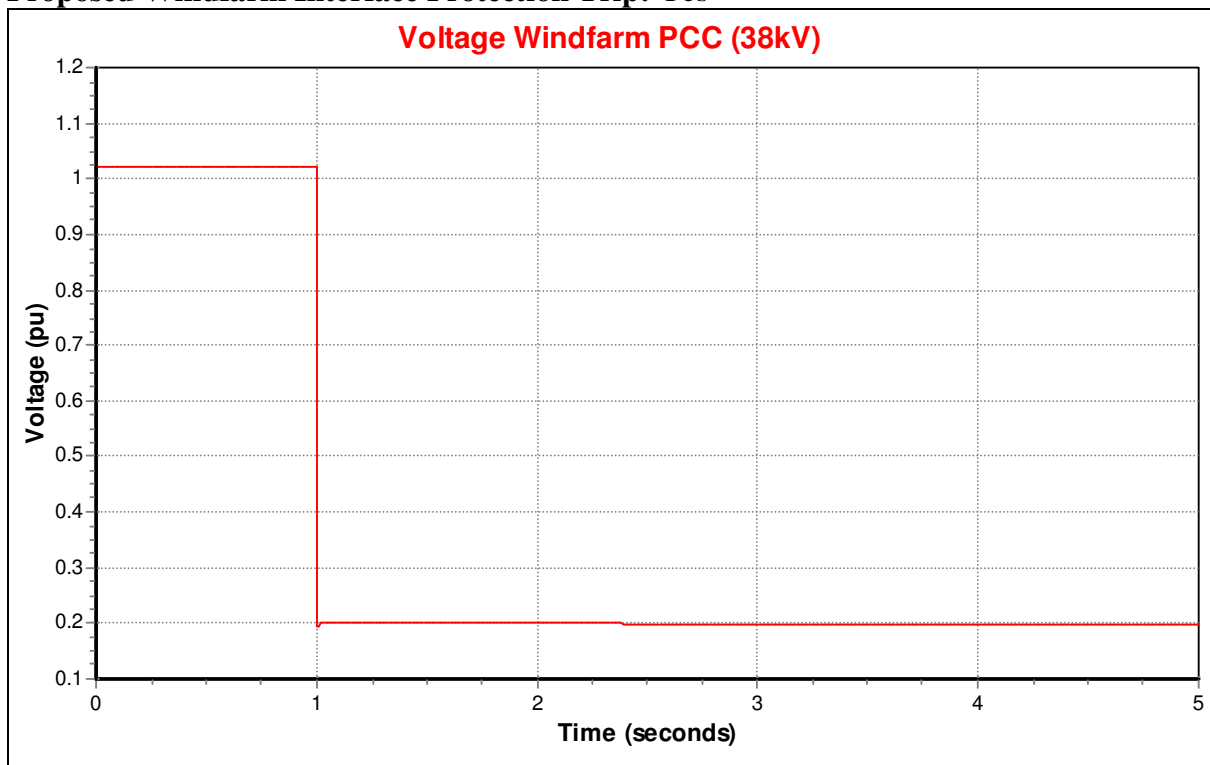

Blank Page

Loss of Mains Event

Scenario 1: Loss of 110/38kV substation

Details:

Results: Summer Night Valley

Wind Farm Output: 15%

Existing Windfarm Interface Protection Trip: Yes

Proposed Windfarm Interface Protection Trip: Yes

Comments: Simulation Unstable

Results: Summer Night Valley

Wind Farm Output: 100%

Existing Windfarm Interface Protection Trip: Yes

Proposed Windfarm Interface Protection Trip: Yes

Comments: Simulation Stable

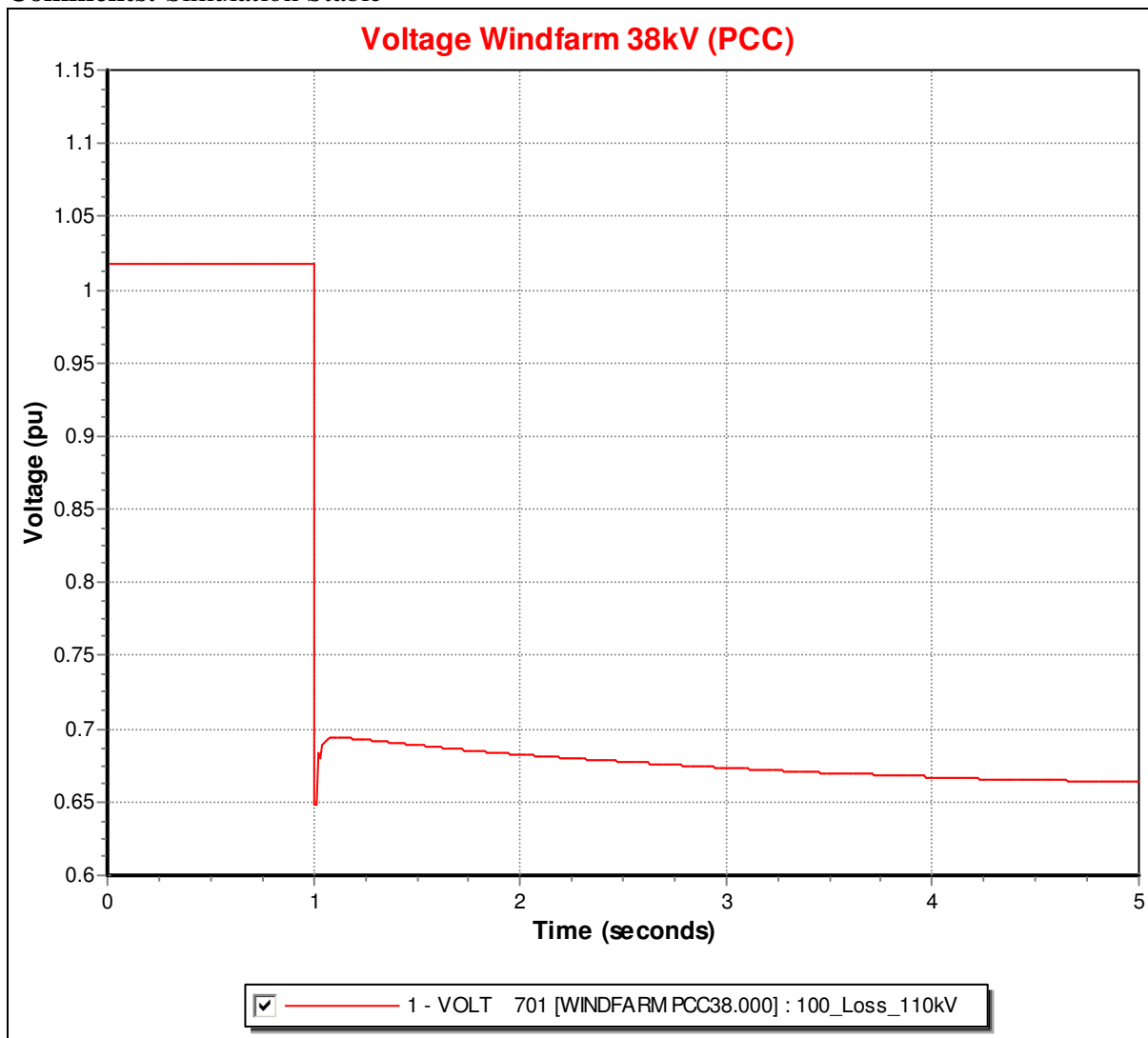

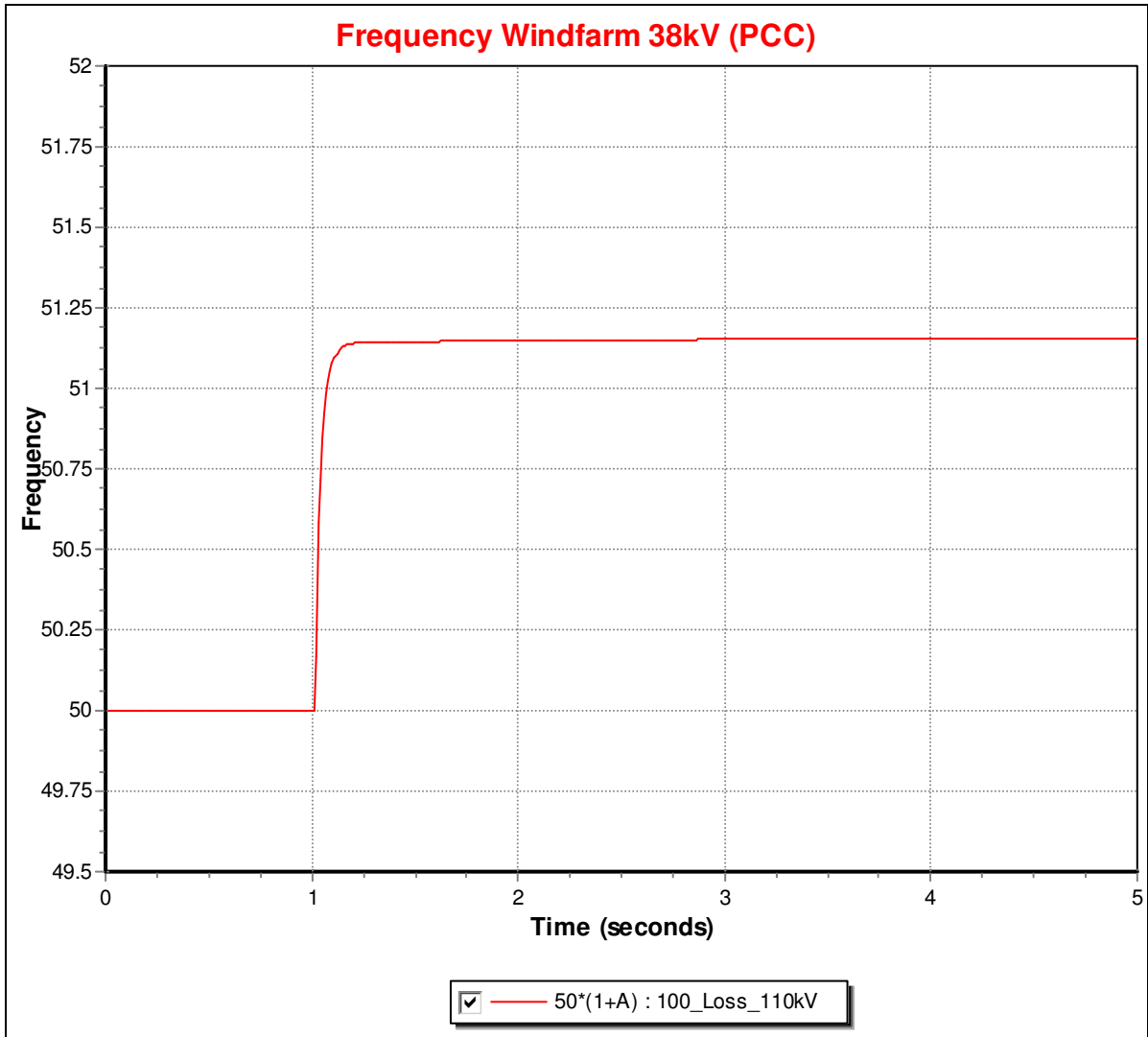

Results: Winter Peak
Wind Farm Output: 15%
Existing Windfarm Interface Protection Trip: Yes
Proposed Windfarm Interface Protection Trip: Yes
Comments: Simulation Unstable

Results: Winter Peak
Wind Farm Output: 100%
Existing Windfarm Interface Protection Trip: Yes
Proposed Windfarm Interface Protection Trip: Yes
Comments: Simulation Unstable

Scenario 2: Loss of 110/38kV substation + 38kV feeder (Substation B –C)

Details:

Results: Summer Night Valley

Wind Farm Output: 15%

Existing Windfarm Interface Protection Trip: Yes

Proposed Windfarm Interface Protection Trip: Yes

Comments: Simulation Unstable

Results: Summer Night Valley

Wind Farm Output: 100%

Existing Windfarm Interface Protection Trip: Yes

Proposed Windfarm Interface Protection Trip: Yes

Comments: Simulation Stable

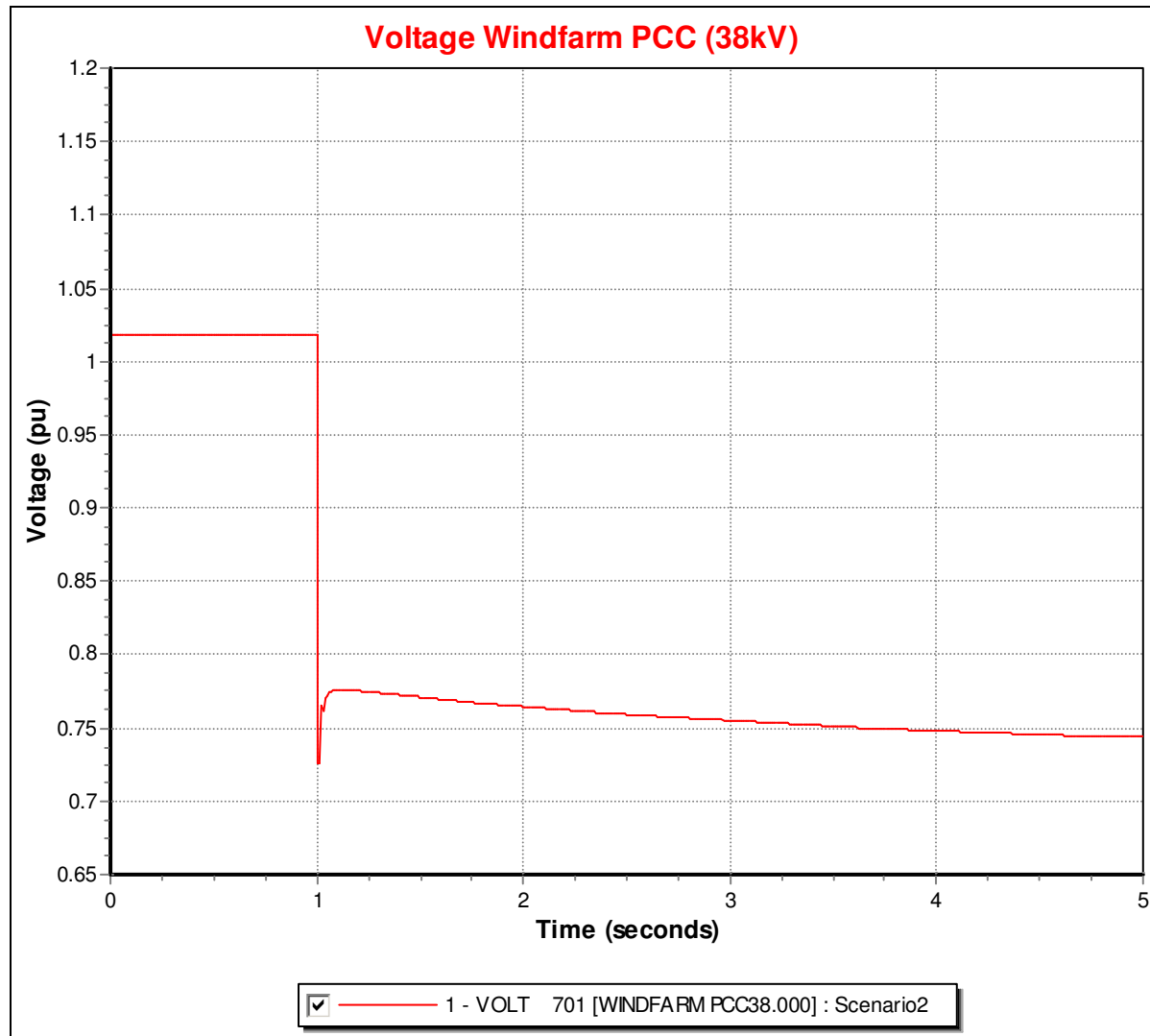

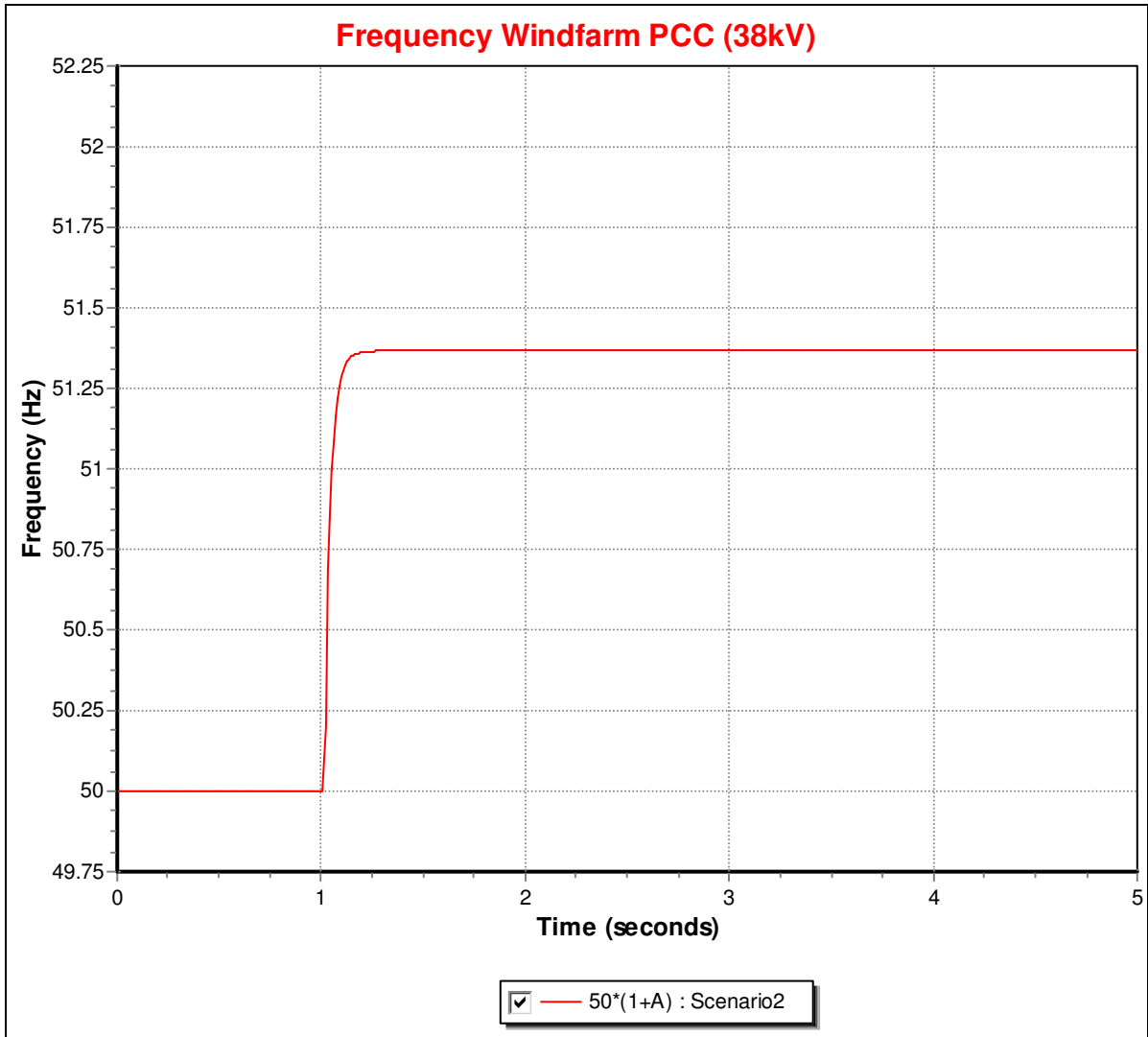

Results: Winter Peak
Wind Farm Output: 15%
Existing Windfarm Interface Protection Trip: Yes
Proposed Windfarm Interface Protection Trip: Yes
Comments: Simulation Unstable

Results: Winter Peak
Wind Farm Output: 100%
Existing Windfarm Interface Protection Trip: Yes
Proposed Windfarm Interface Protection Trip: Yes
Comments: Simulation Unstable

Scenario 3: Loss of 110/38kV substation + (110/38KV Substation – C)

Details:

Results: Summer Night Valley

Wind Farm Output: 15%

Existing Windfarm Interface Protection Trip: Yes

Proposed Windfarm Interface Protection Trip: Yes

Comments: Simulation Stable

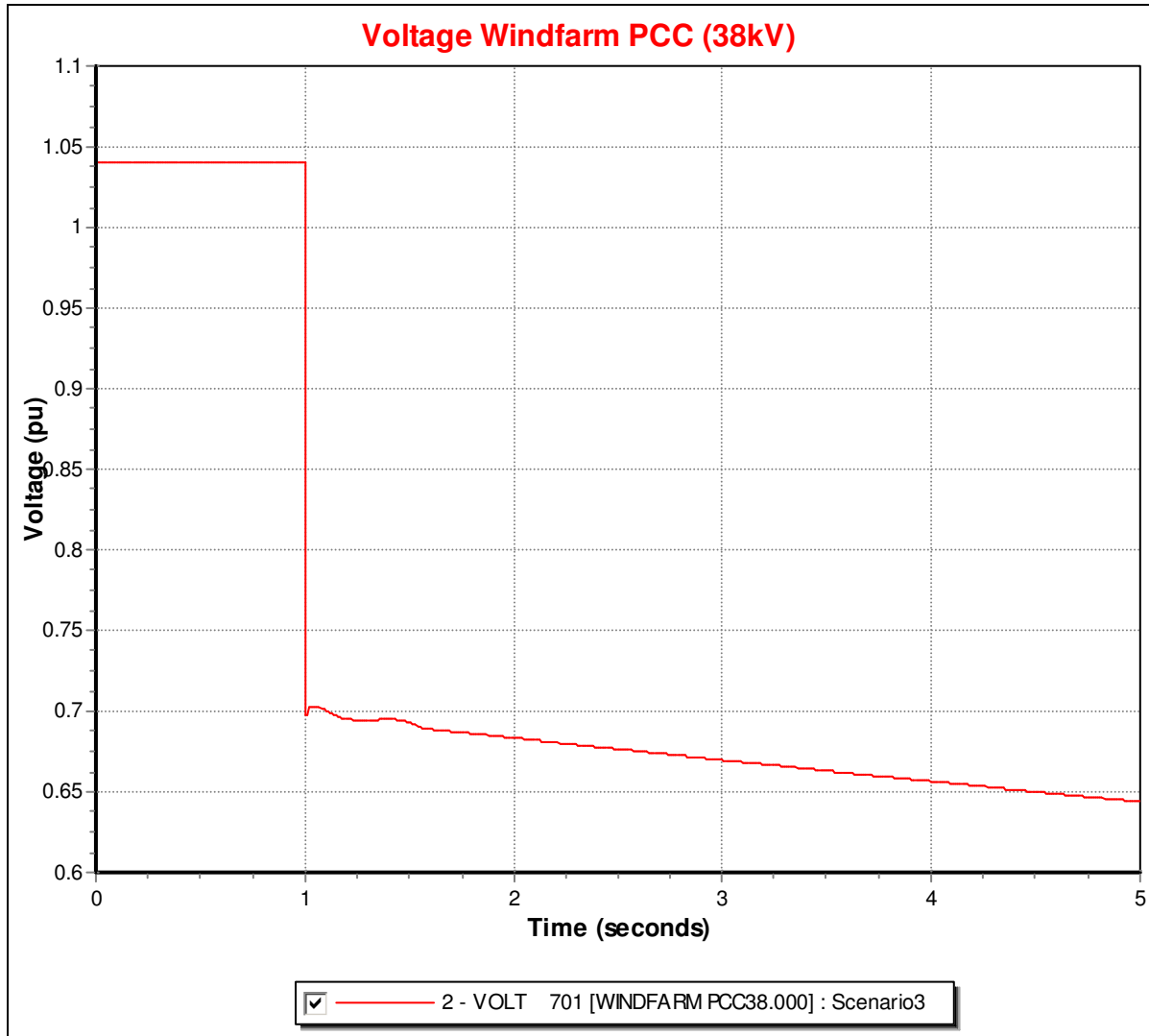

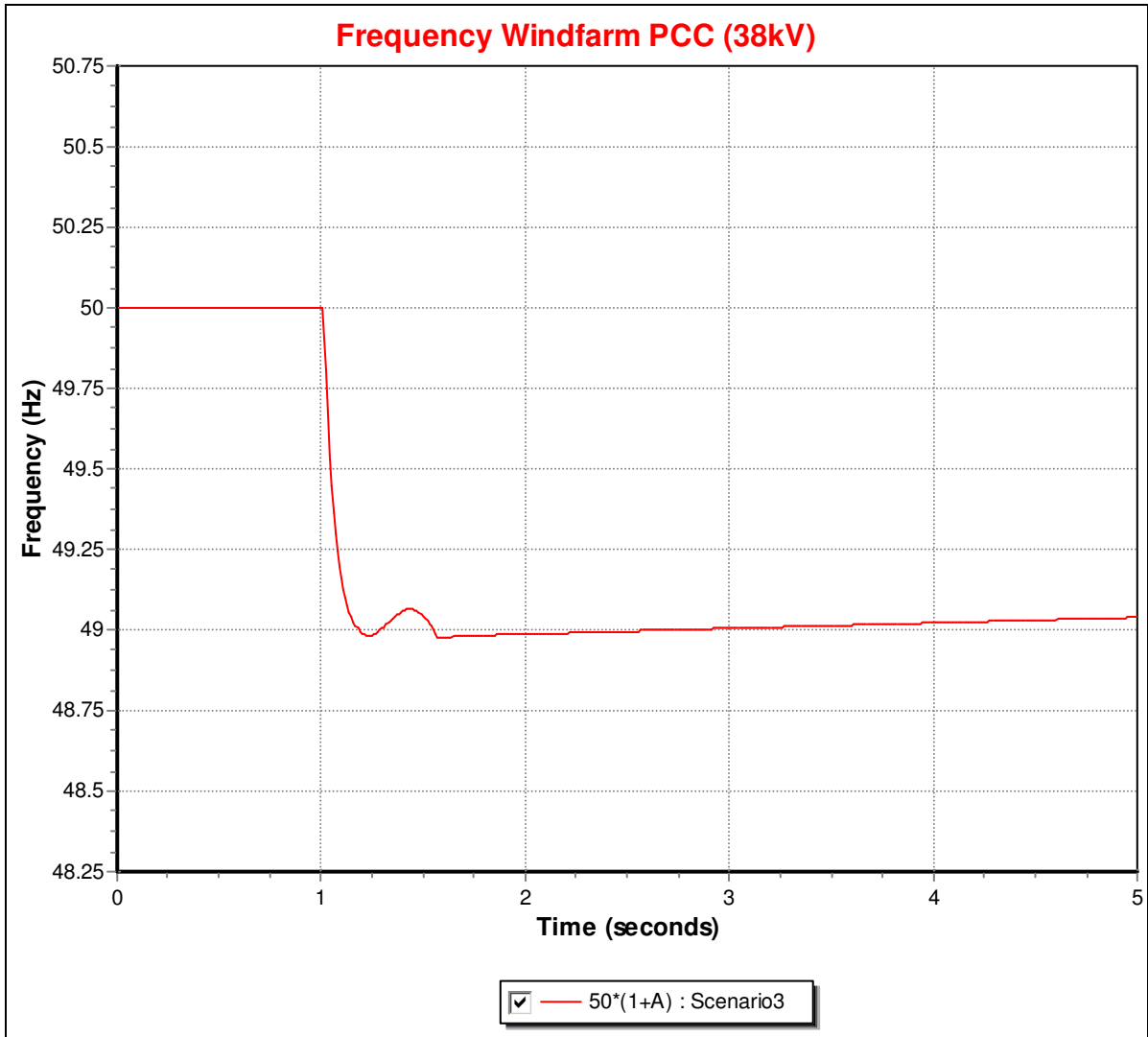

Results: Summer Night Valley
Wind Farm Output: 100%
Existing Windfarm Interface Protection Trip: Yes
Proposed Windfarm Interface Protection Trip: Yes
Comments: Simulation Stable

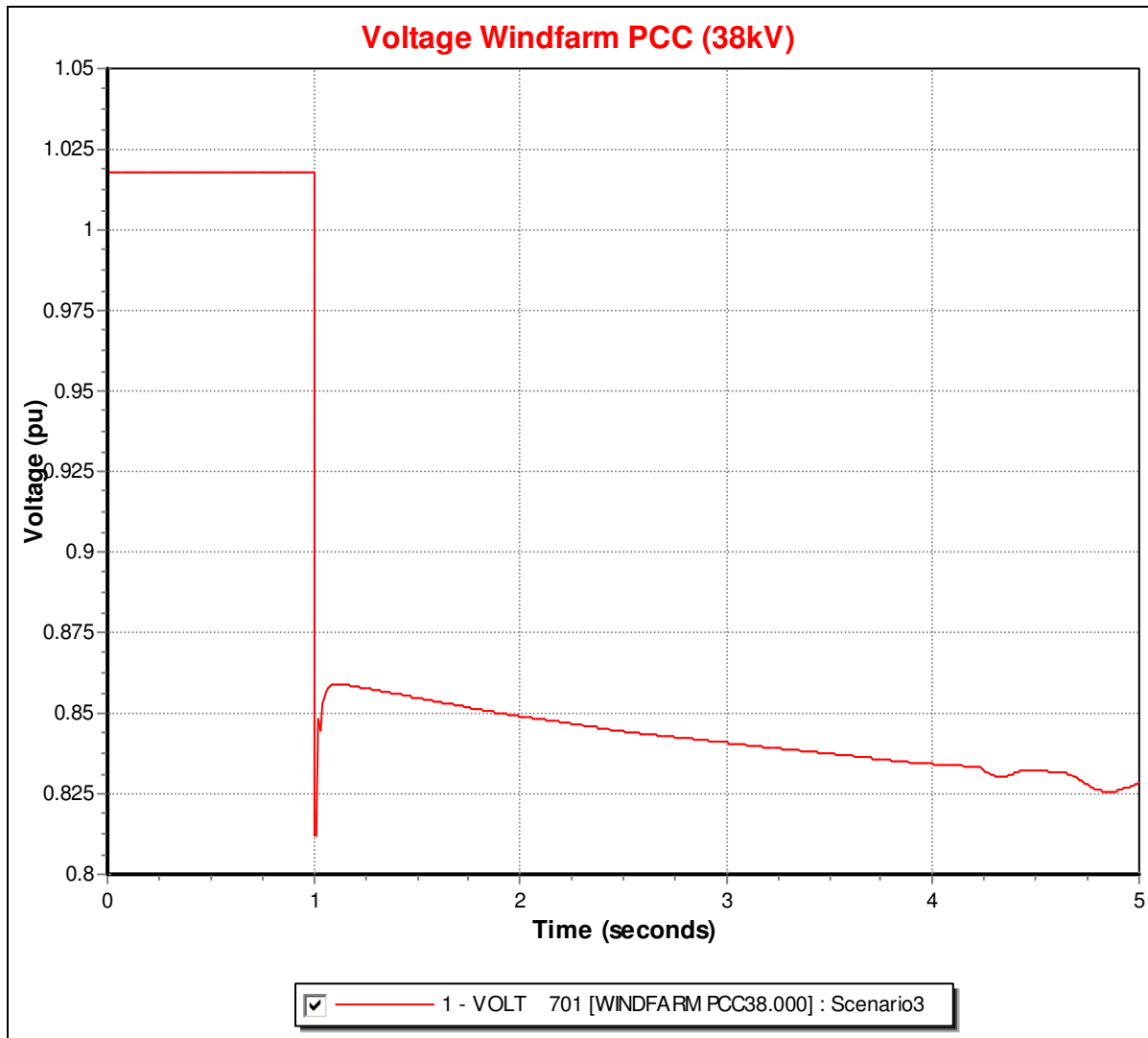

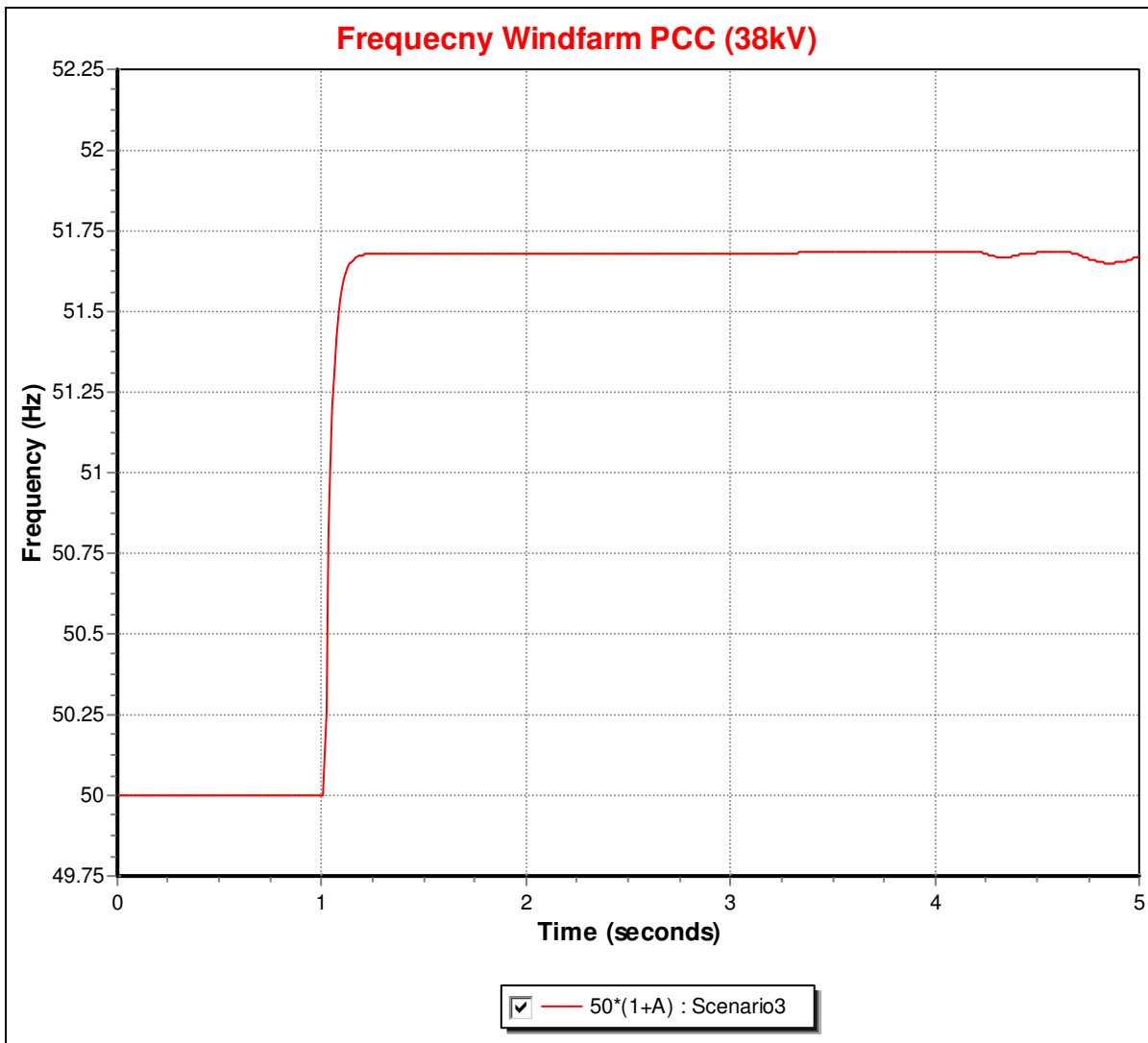

Results: Winter Peak
Wind Farm Output: 15%
Existing Windfarm Interface Protection Trip: Yes
Proposed Windfarm Interface Protection Trip: Yes
Comments: Simulation Unstable

Results: Winter Peak
Wind Farm Output: 100%
Existing Windfarm Interface Protection Trip: Yes
Proposed Windfarm Interface Protection Trip: Yes
Comments: Simulation Unstable

Scenario 4: Loss of 110/38kV substation + (110/38KV Substation – D)

Details:

Results: Summer Night Valley

Wind Farm Output: 15%

Existing Windfarm Interface Protection Trip: Yes

Proposed Windfarm Interface Protection Trip: Yes

Comments: Simulation Stable

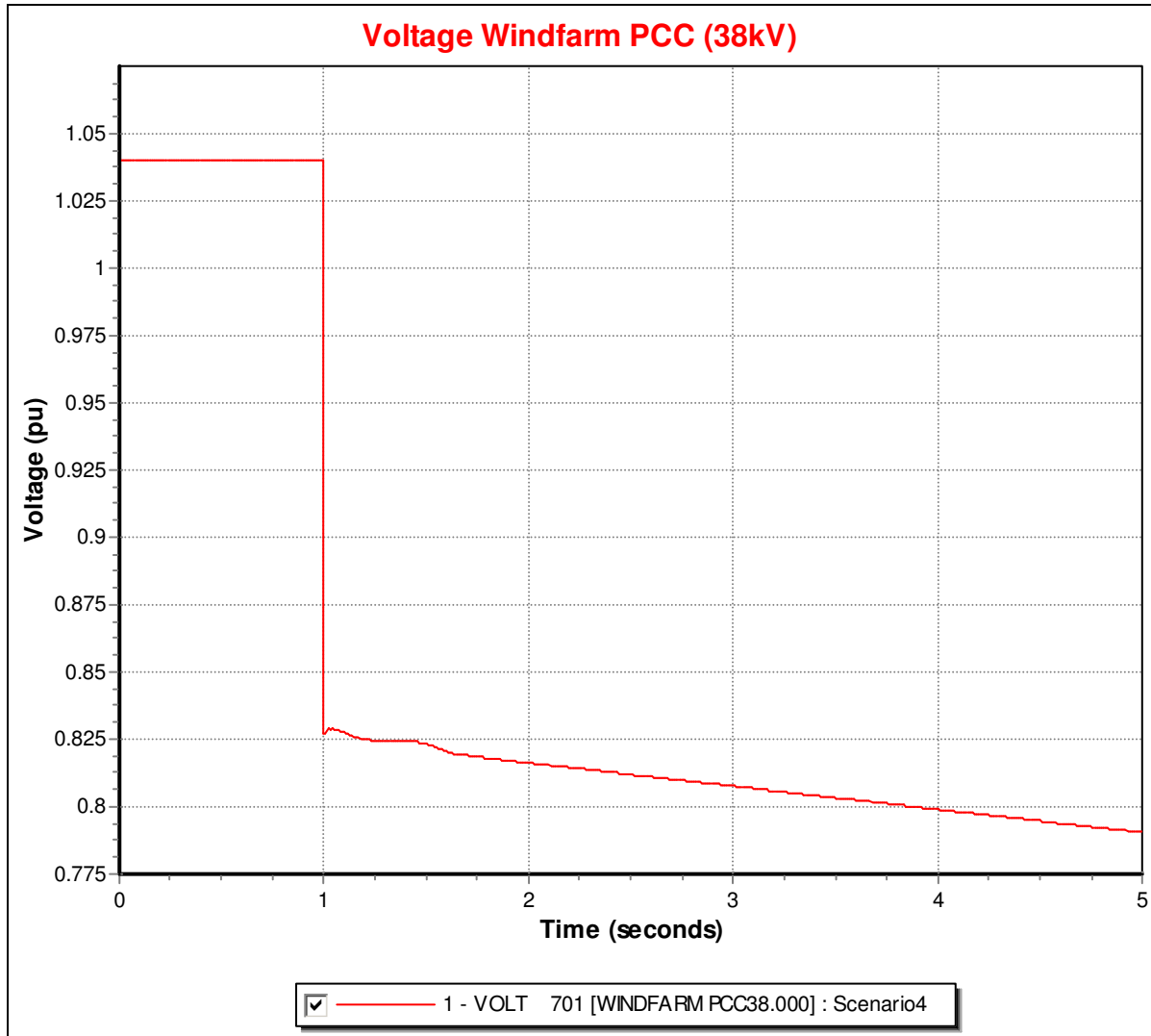

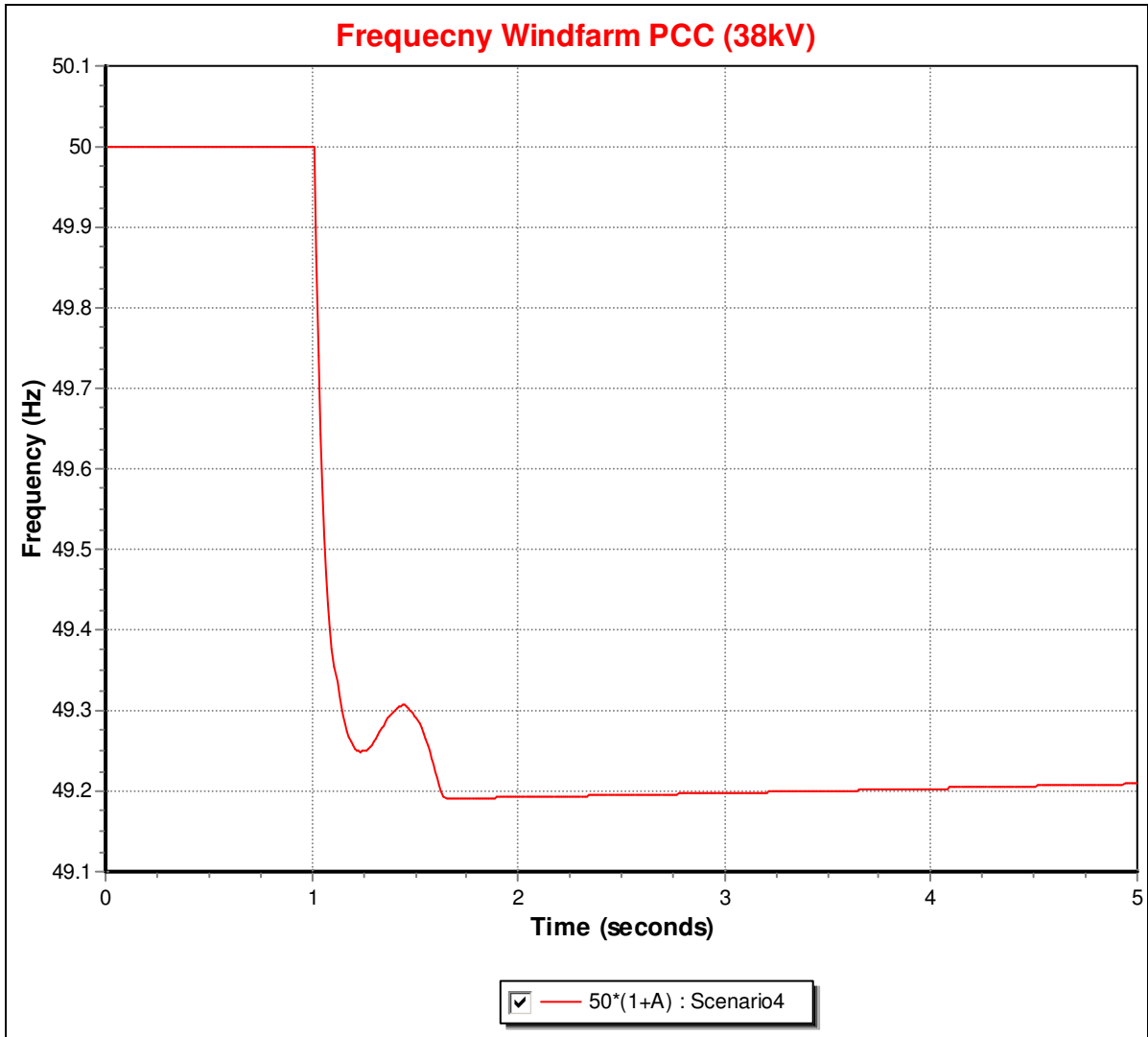

Results: Summer Night Valley
Wind Farm Output: 100%
Existing Windfarm Interface Protection Trip: Yes
Proposed Windfarm Interface Protection Trip: Yes
Comments: Simulation Stable

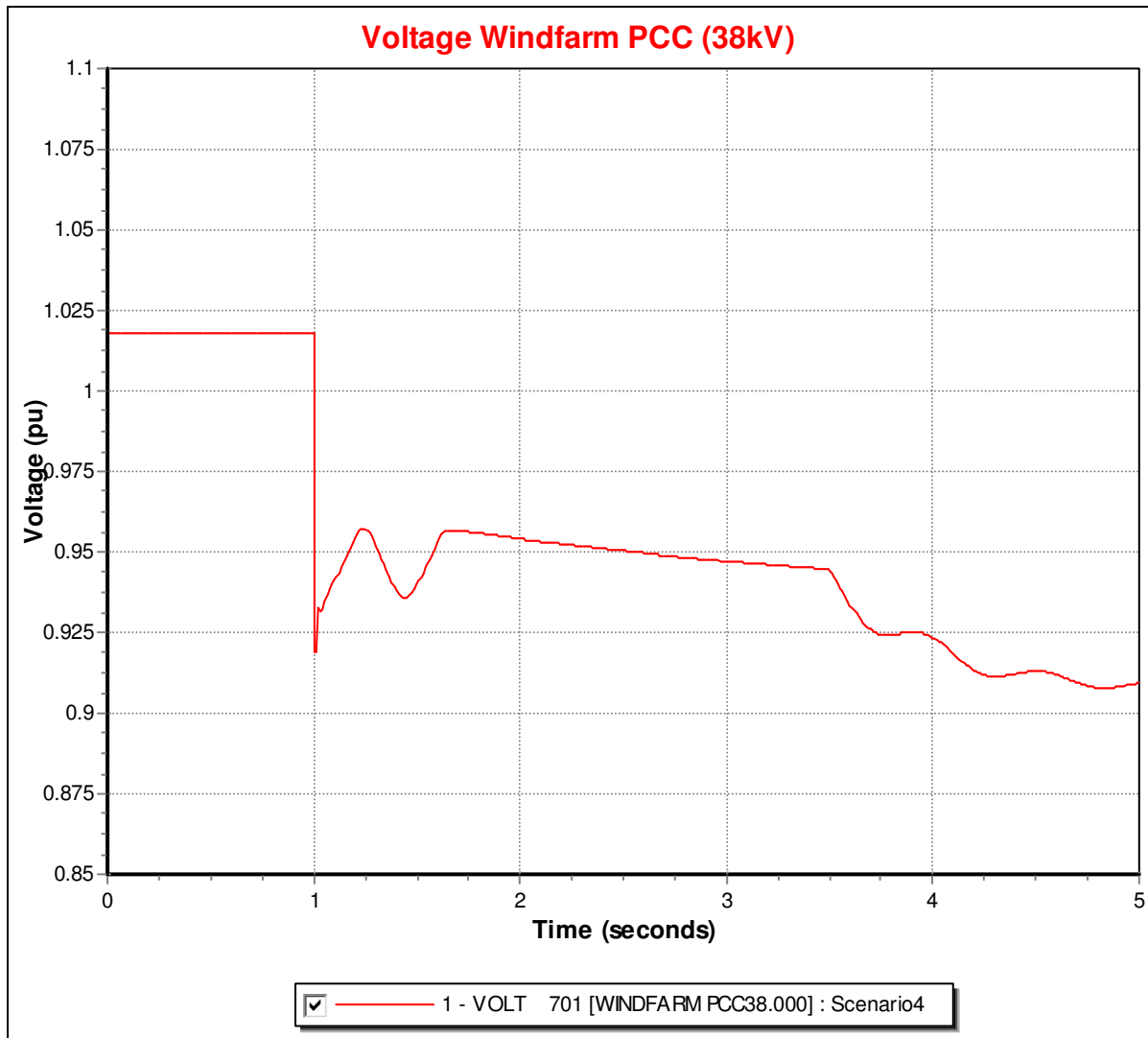

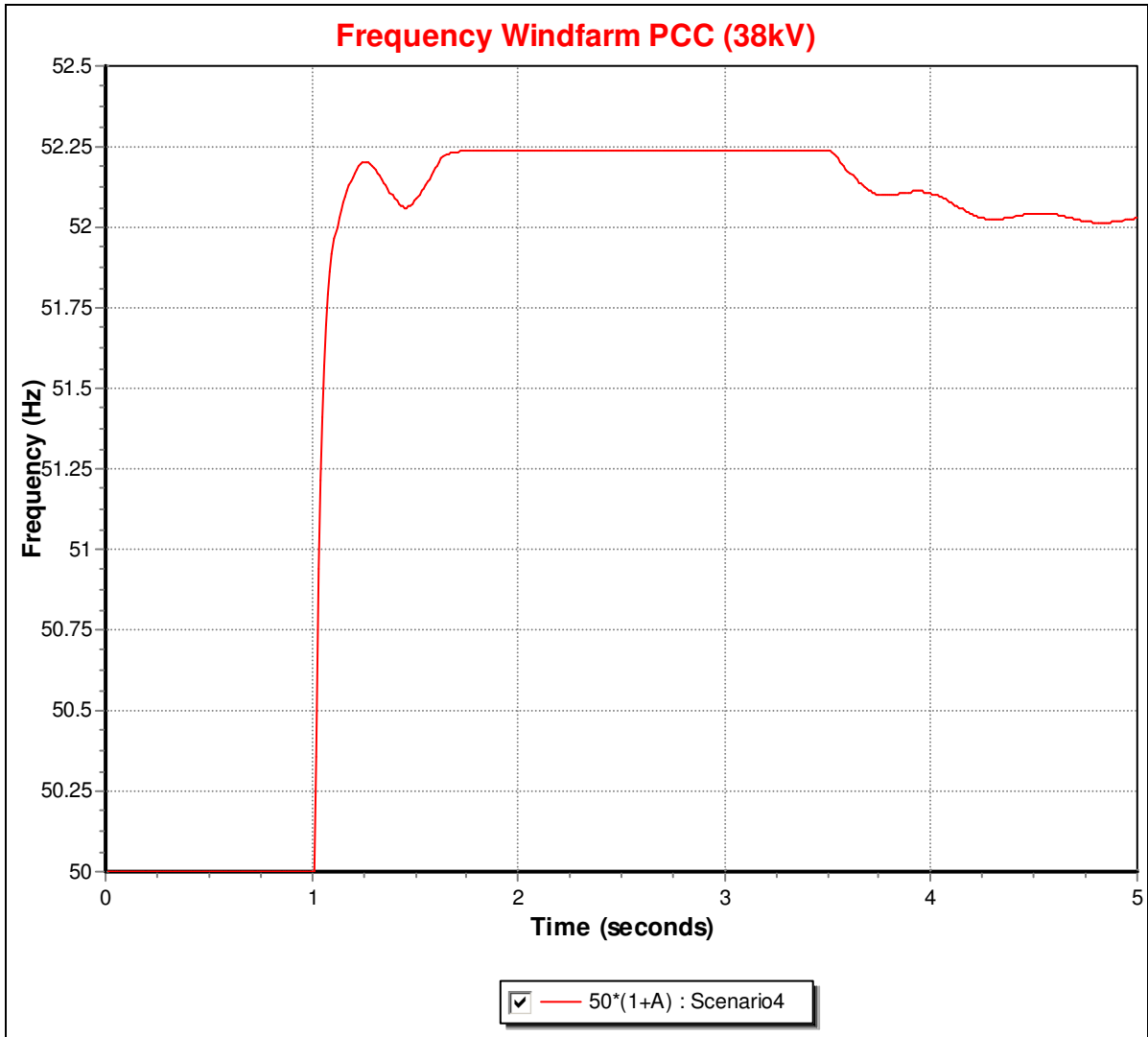

Results: Winter Peak
Wind Farm Output: 15%
Existing Windfarm Interface Protection Trip: Yes
Proposed Windfarm Interface Protection Trip: Yes
Comments: Simulation Unstable

Results: Winter Peak
Wind Farm Output: 100%
Existing Windfarm Interface Protection Trip: Yes
Proposed Windfarm Interface Protection Trip: Yes
Comments: Simulation Stable

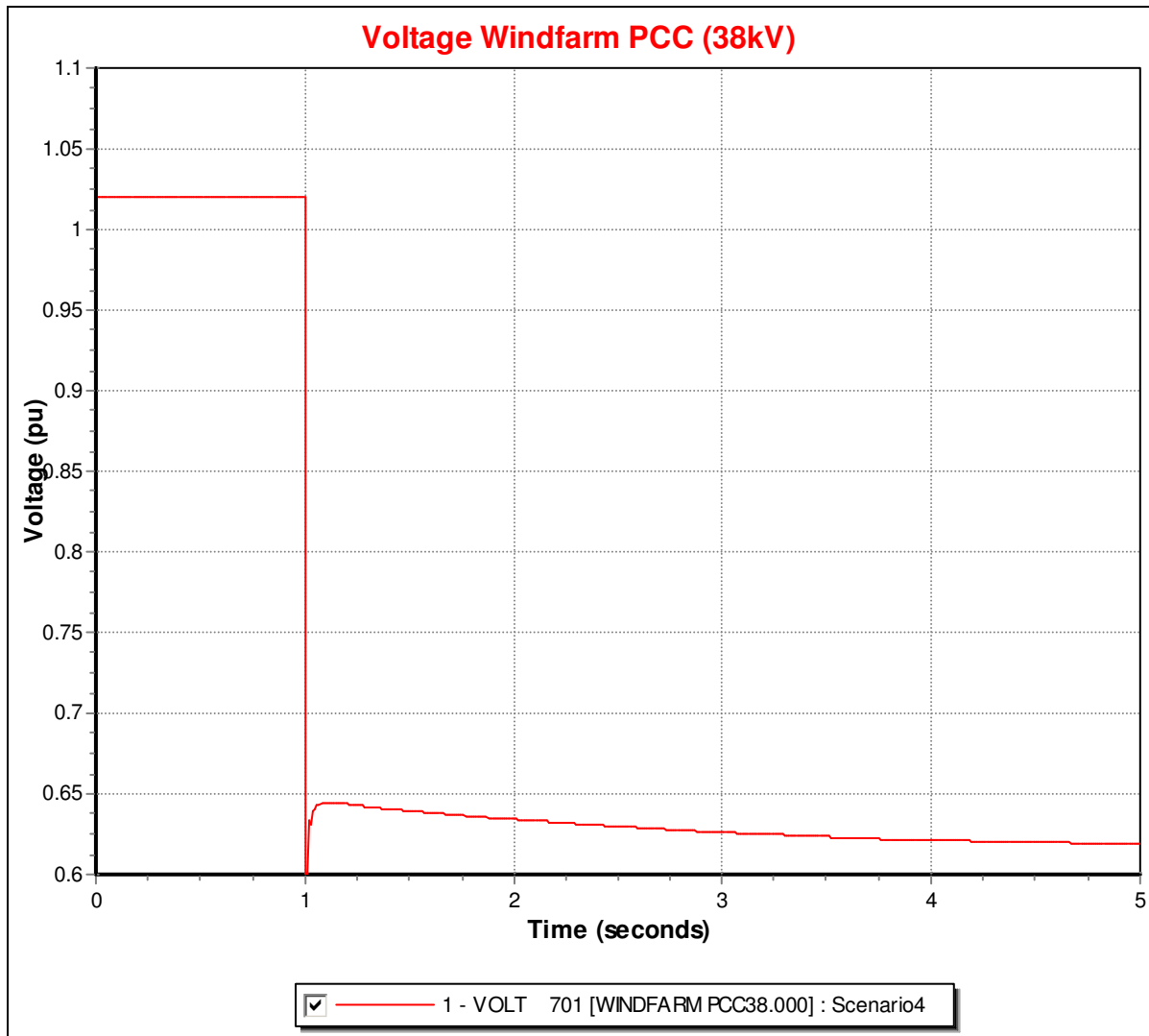

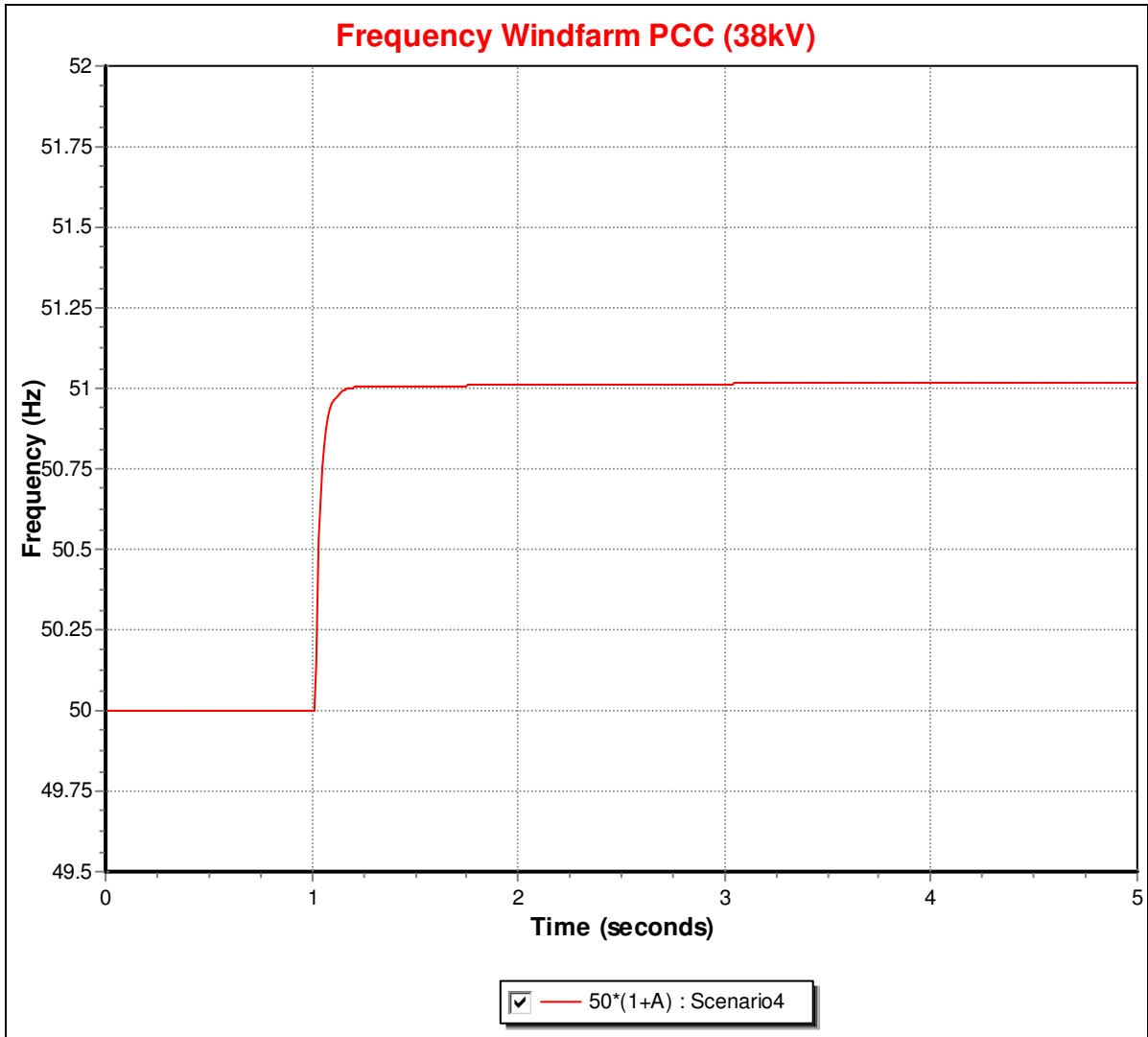

Scenario 5: Loss of 110/38kV substation + (110/38KV Substation – F)

Details:

Results: Summer Night Valley

Wind Farm Output: 15%

Existing Windfarm Interface Protection Trip: Yes

Proposed Windfarm Interface Protection Trip: Yes

Comments: Simulation Stable

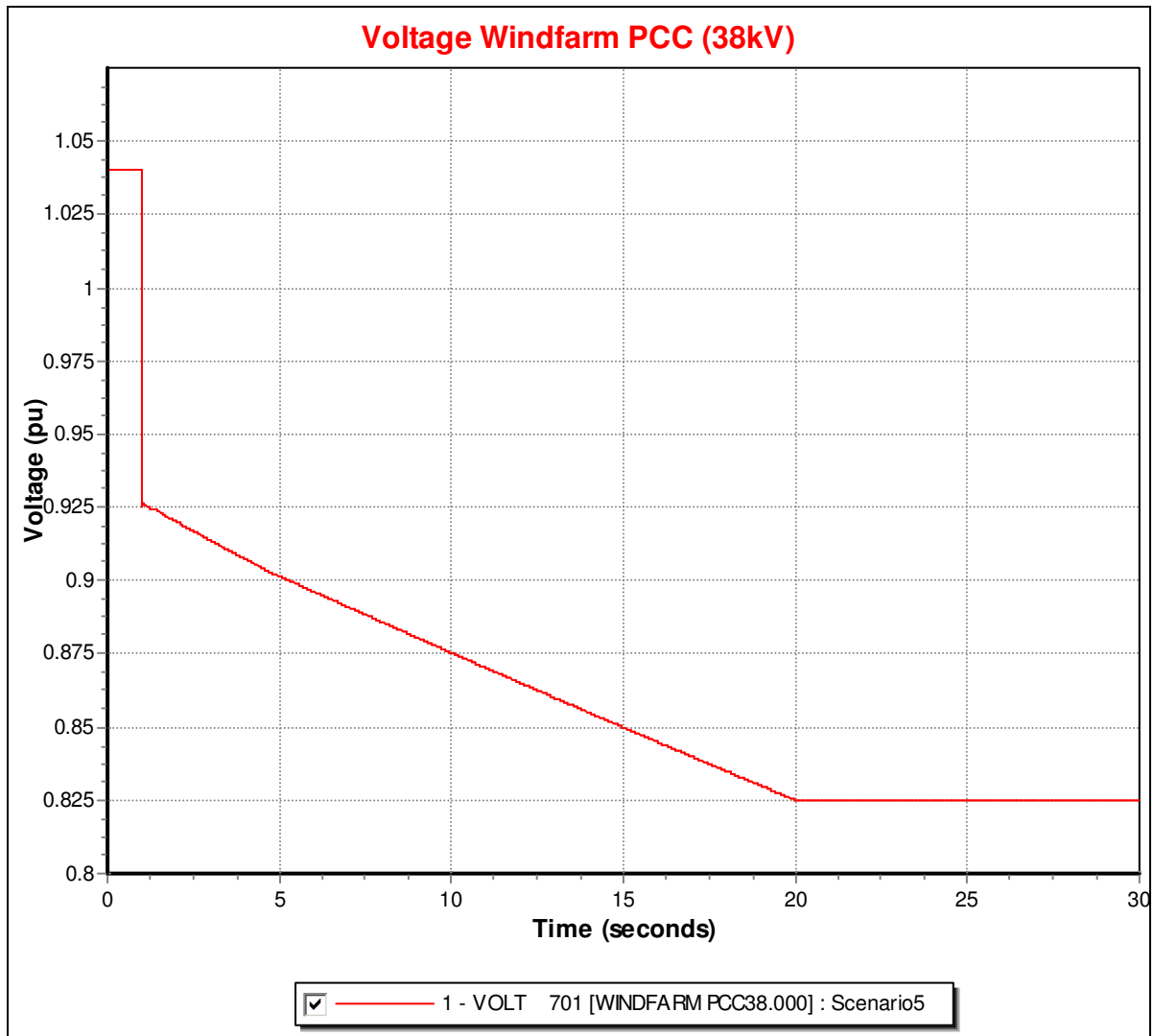

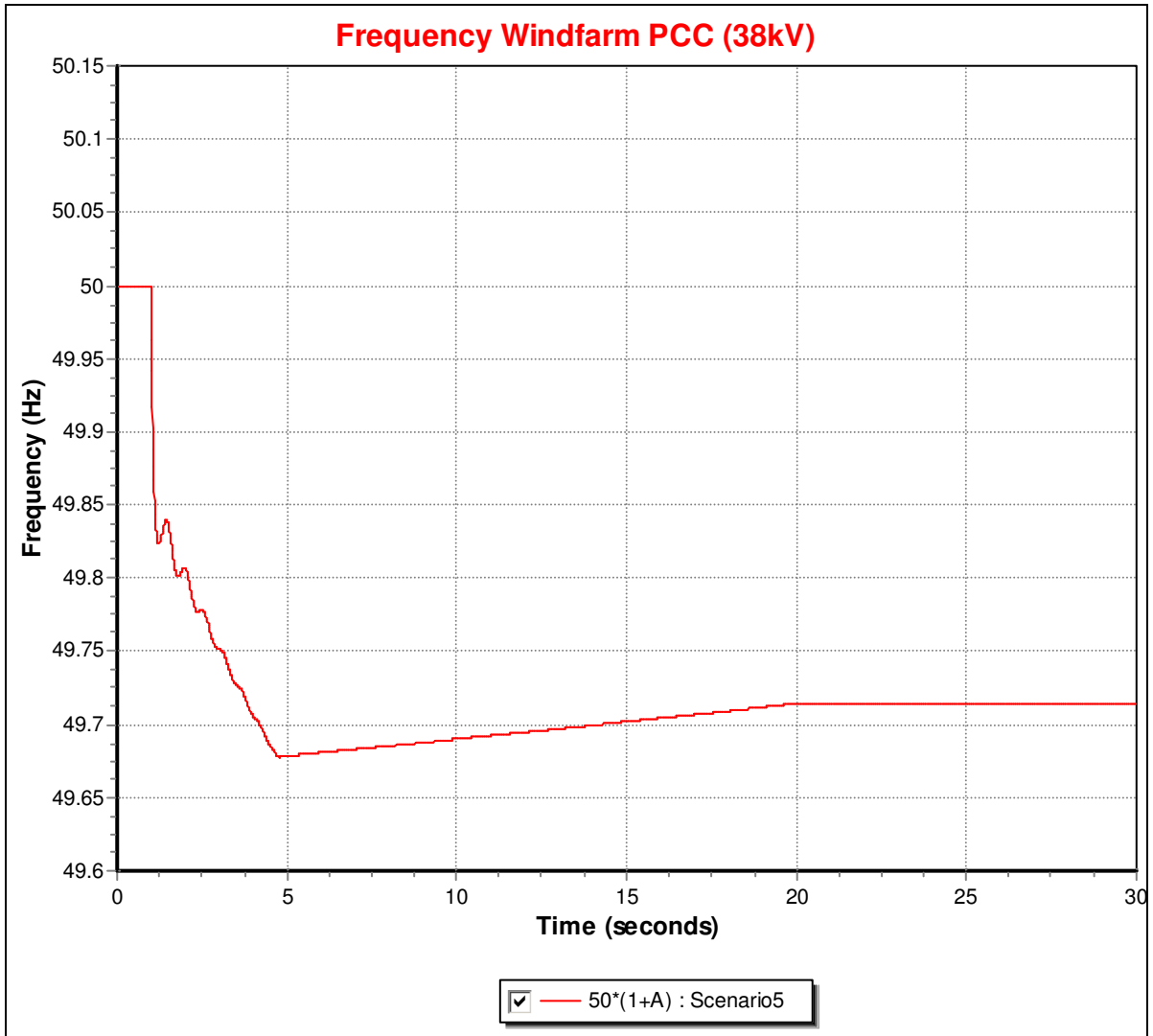

Results: Summer Night Valley
Wind Farm Output: 100%
Existing Windfarm Interface Protection Trip: Yes
Proposed Windfarm Interface Protection Trip: Yes
Comments: Simulation Stable

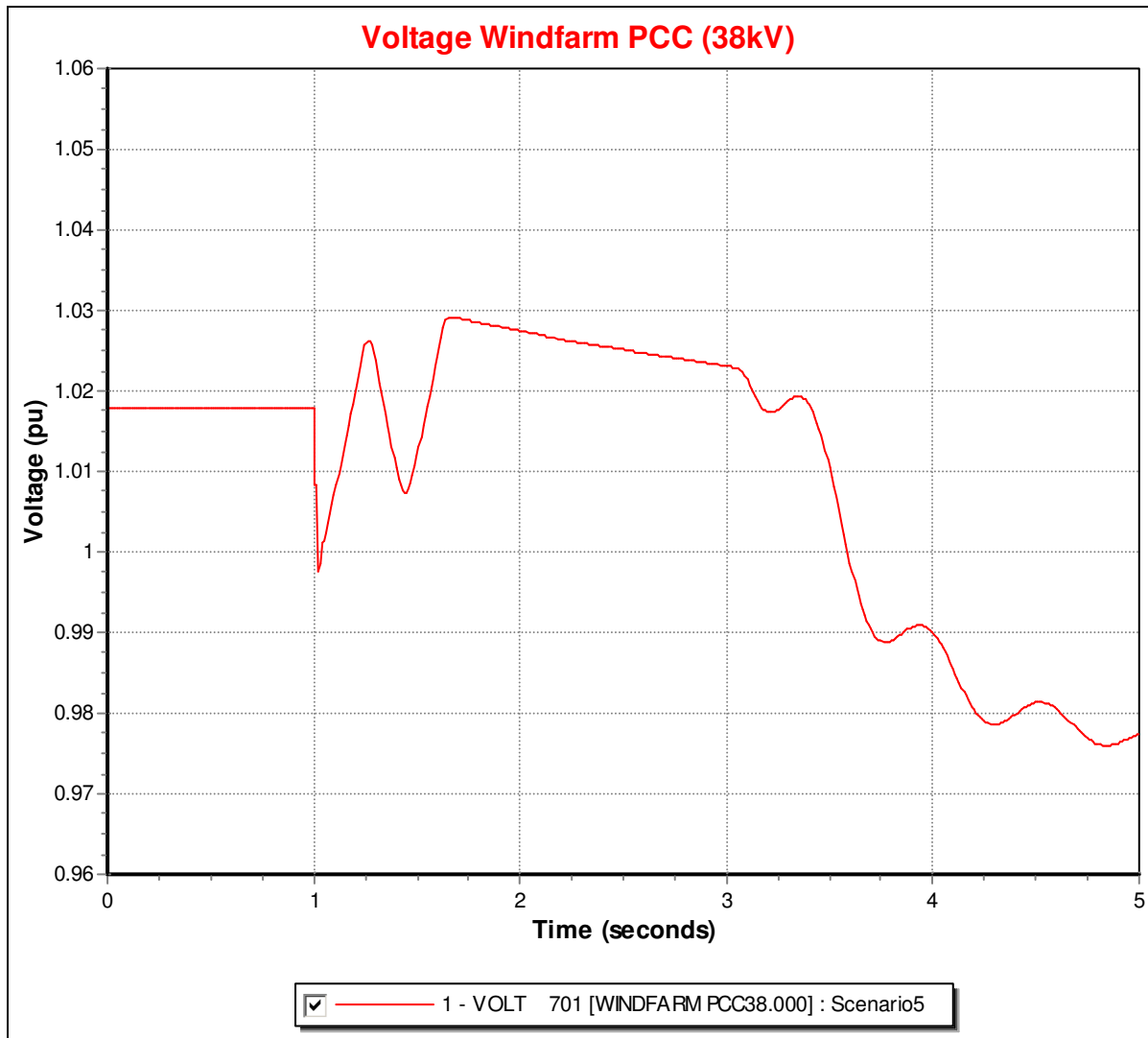

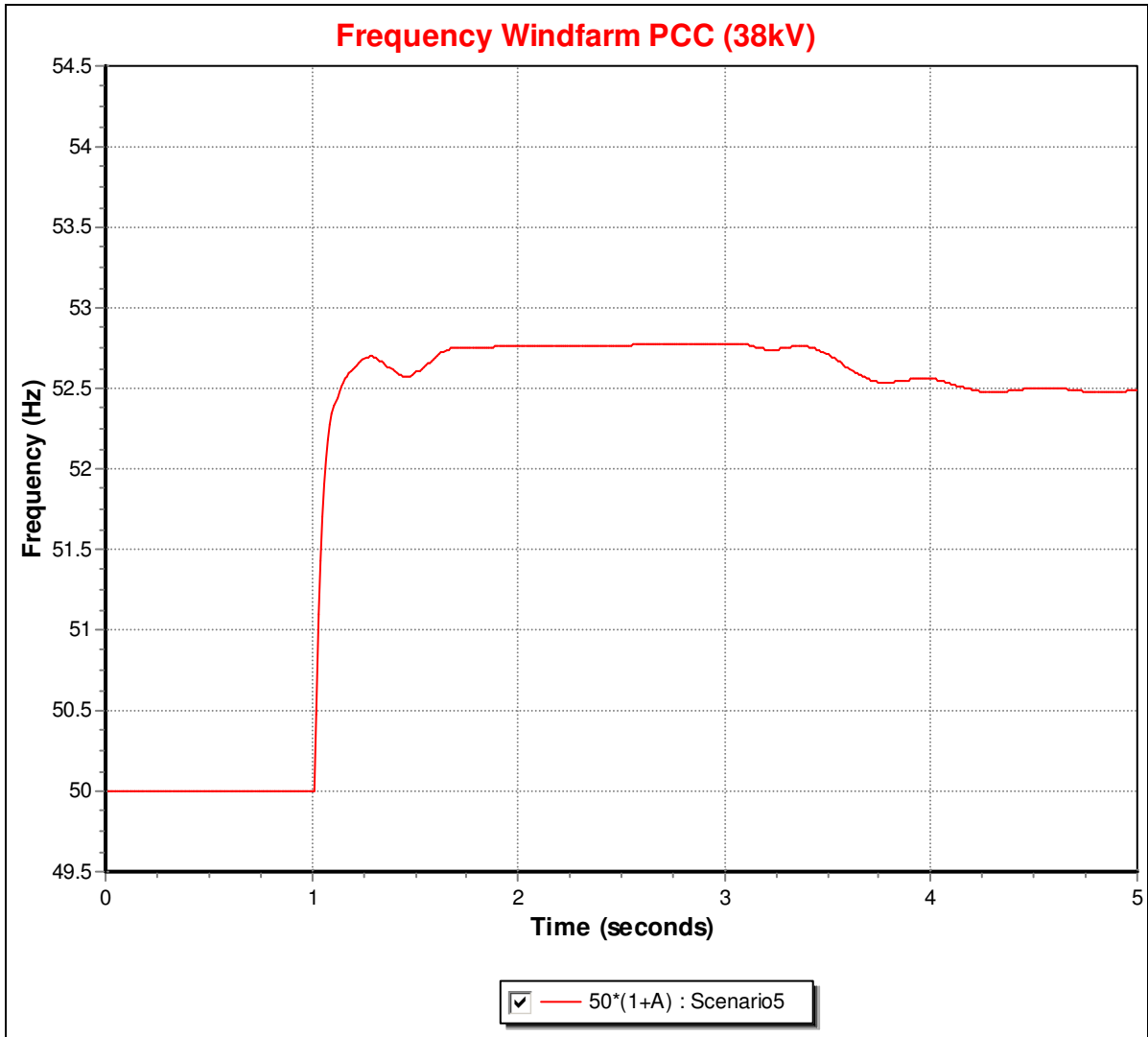

Results: Winter Peak
Wind Farm Output: 15%
Existing Windfarm Interface Protection Trip: Yes
Proposed Windfarm Interface Protection Trip: Yes
Comments: Simulation Stable

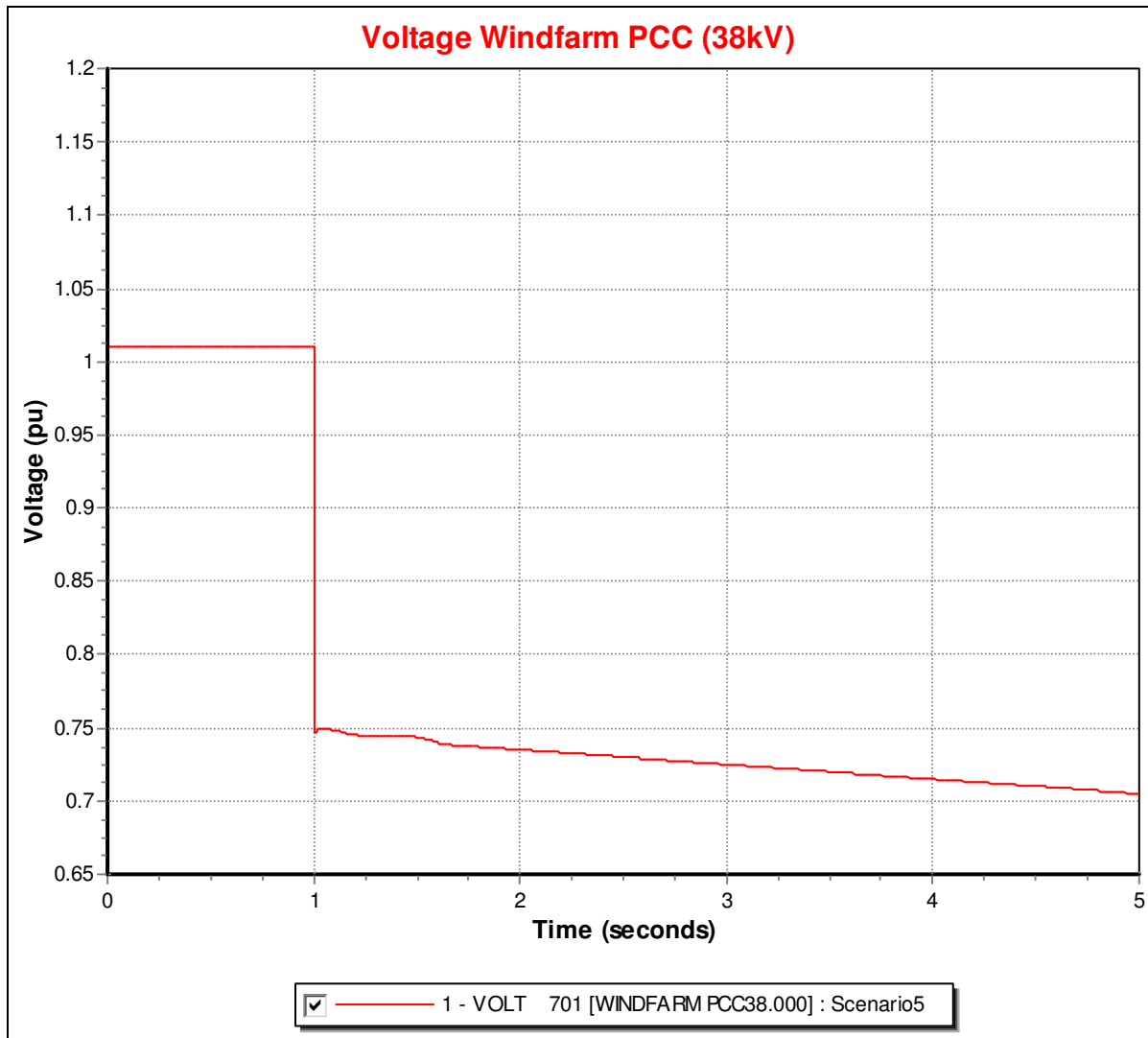

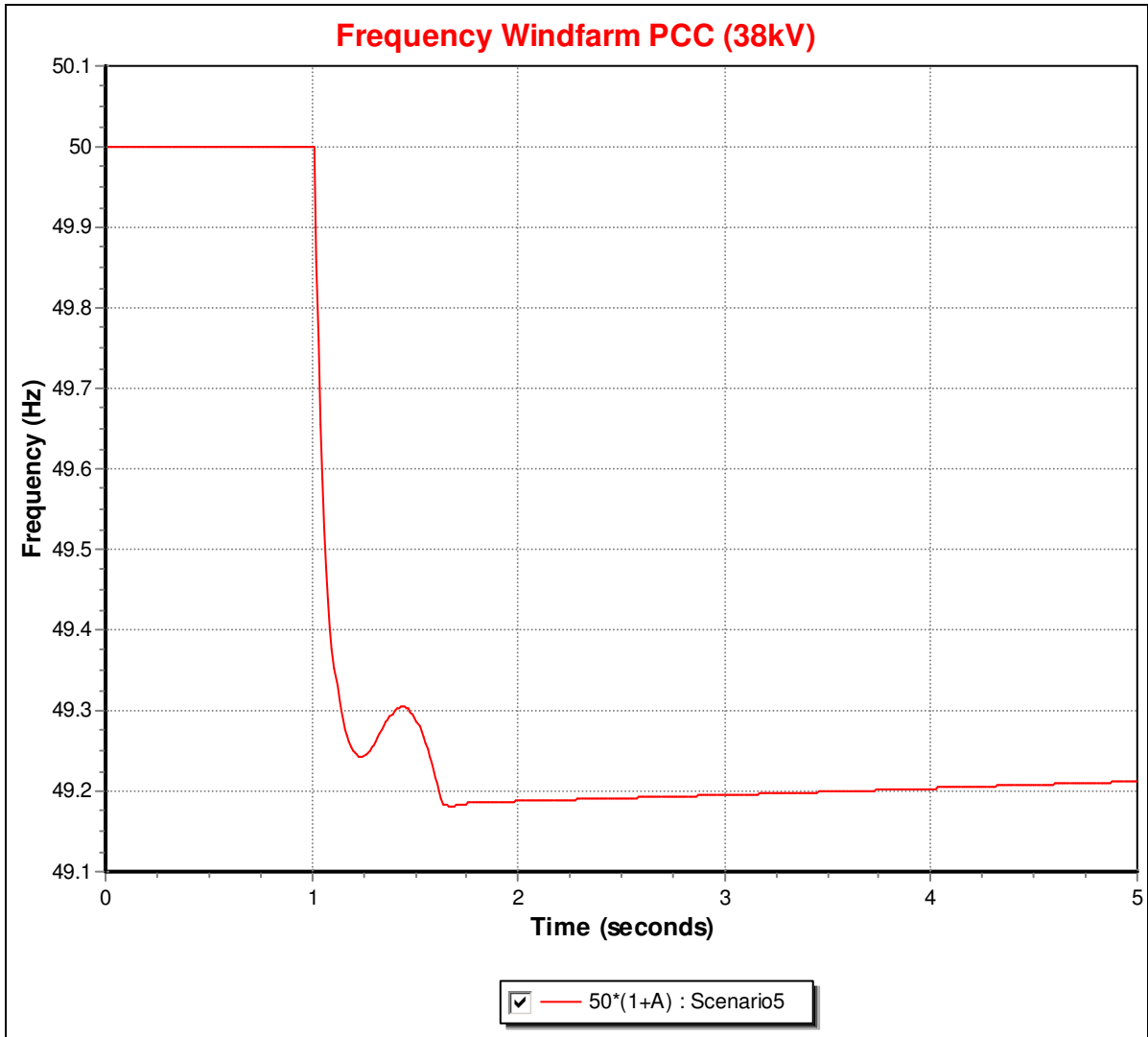

Results: Winter Peak
Wind Farm Output: 100%
Existing Windfarm Interface Protection Trip: Yes
Proposed Windfarm Interface Protection Trip: Yes
Comments: Simulation Stable

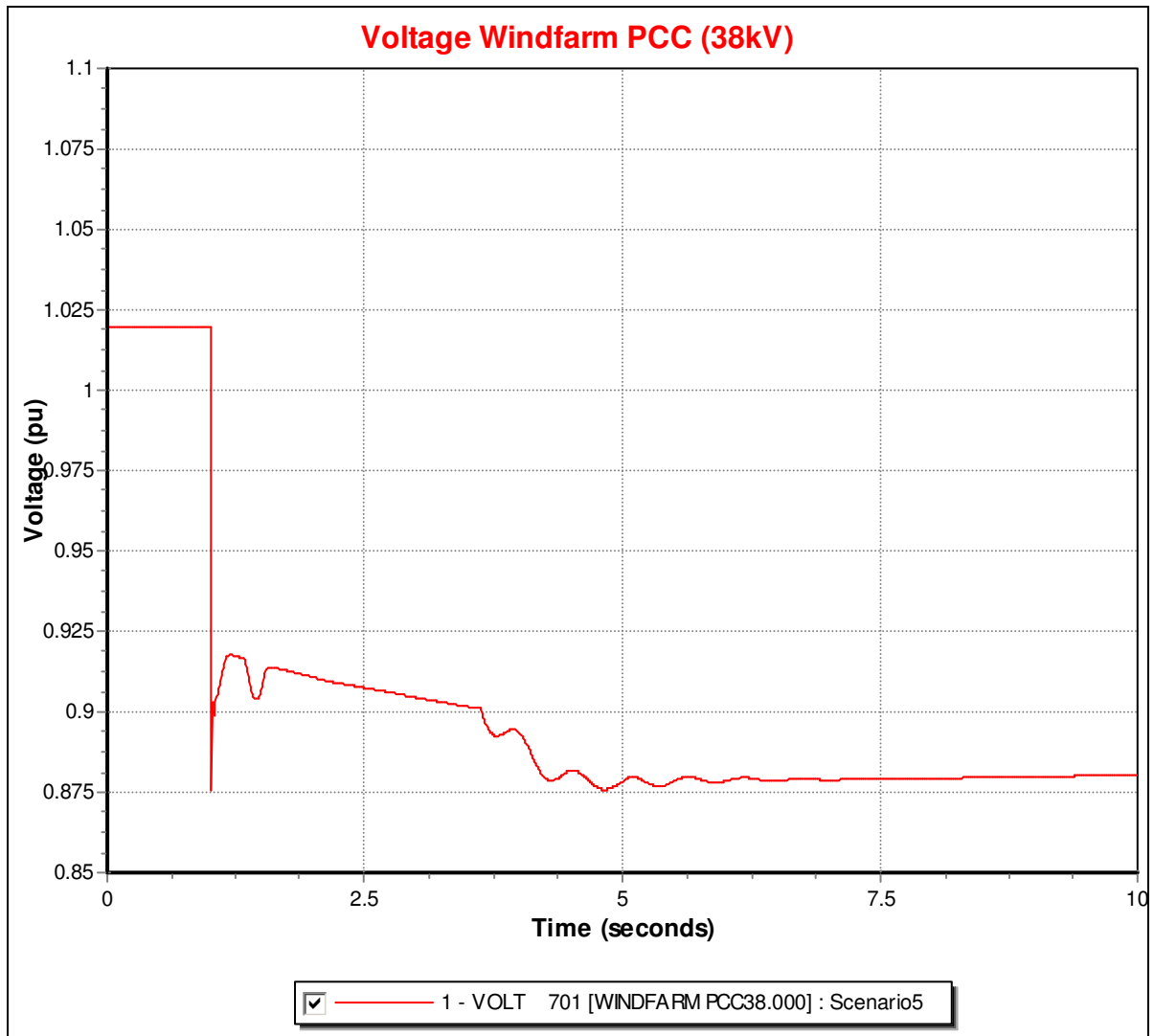

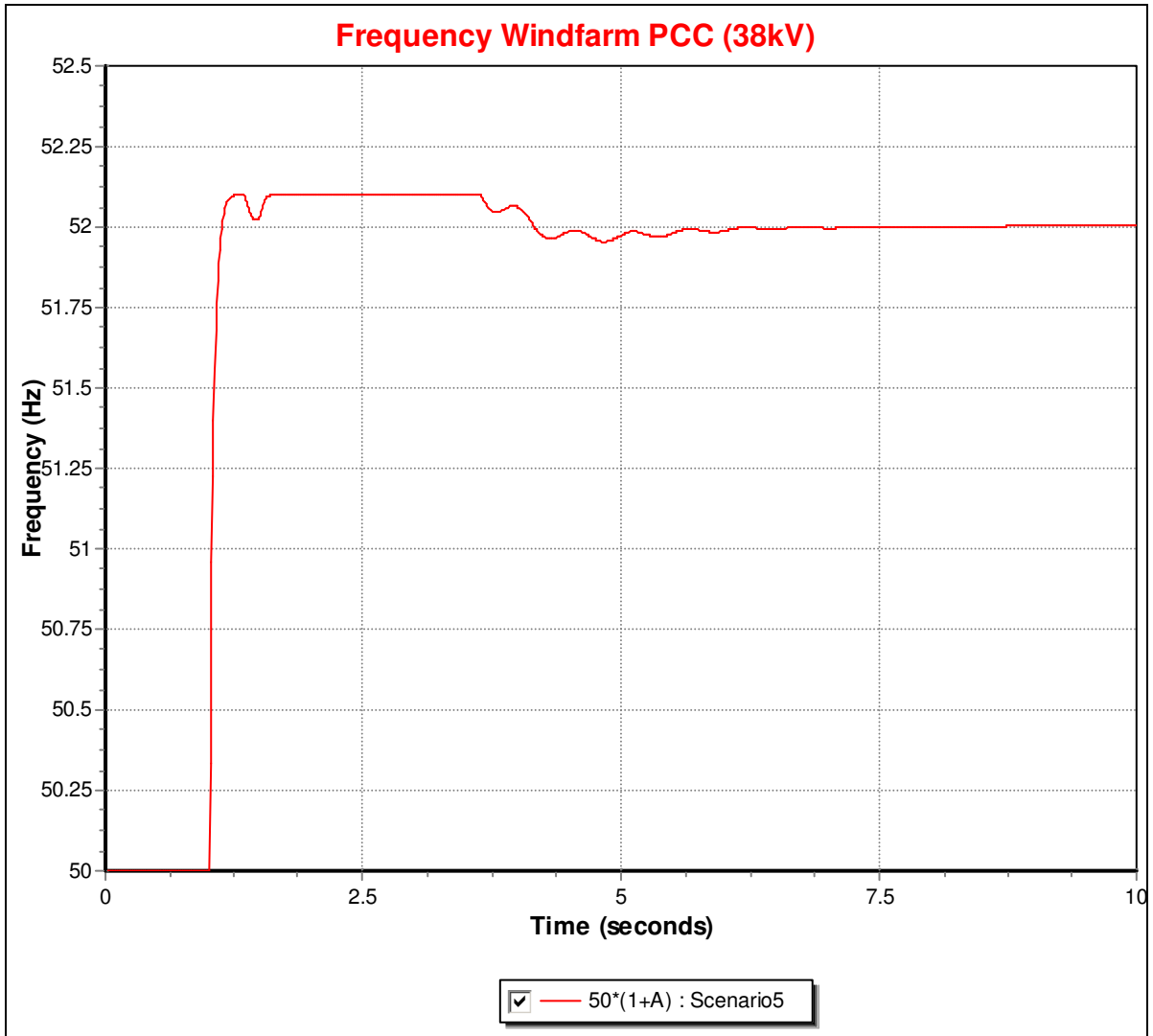

Scenario 6: Loss of 110/38kV substation + 38kV feeder (Substation D – E)

Details:

Results: Summer Night Valley

Wind Farm Output: 15%

Existing Windfarm Interface Protection Trip: Yes

Proposed Windfarm Interface Protection Trip: Yes

Comments: Simulation Stable

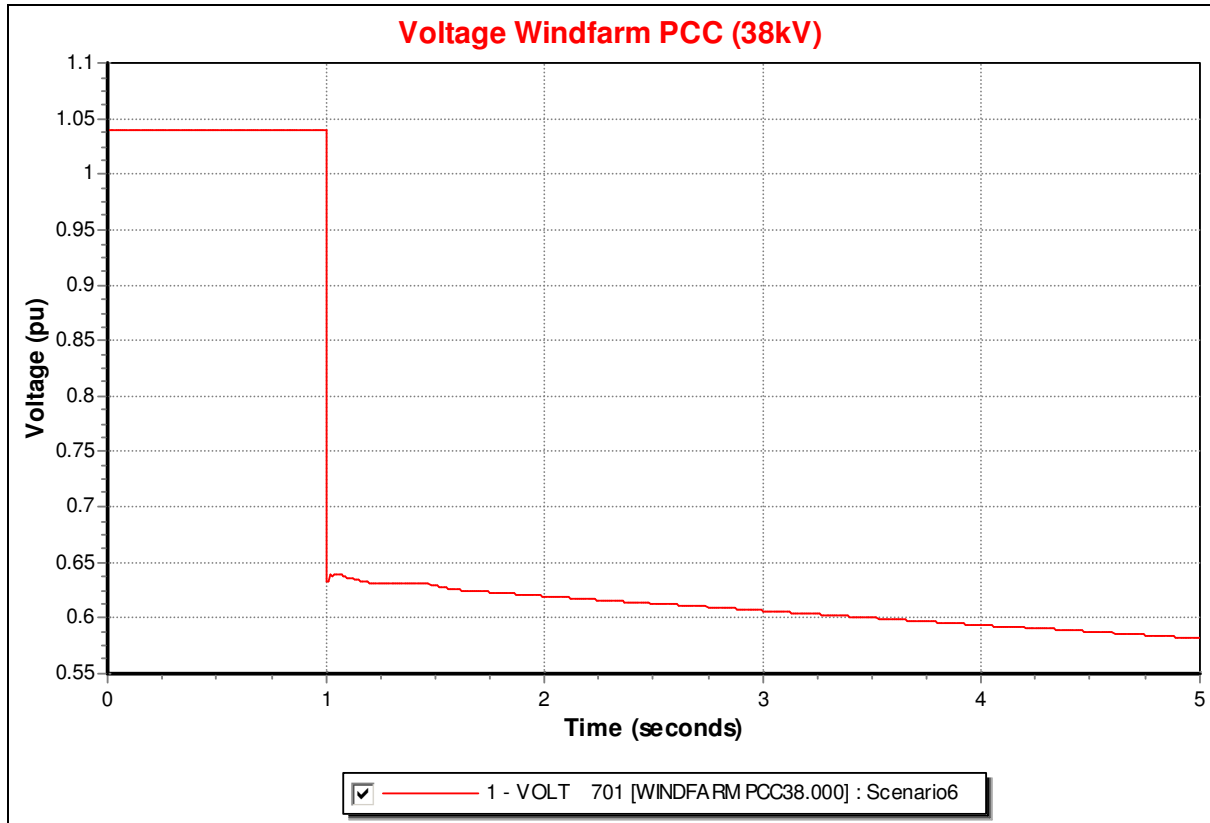

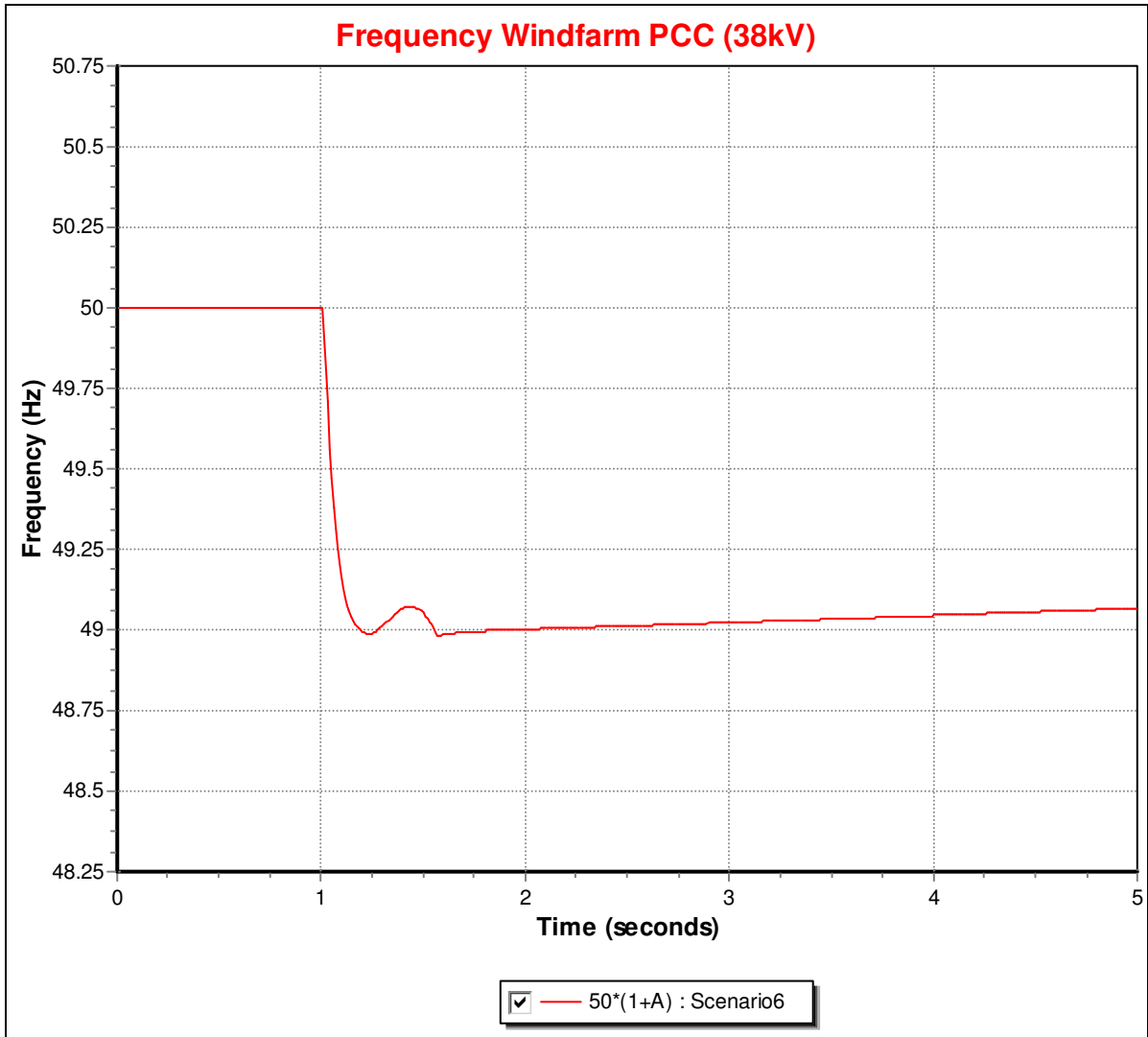

Results: Summer Night Valley
Wind Farm Output: 100%
Existing Windfarm Interface Protection Trip: Yes
Proposed Windfarm Interface Protection Trip: Yes
Comments: Simulation Stable

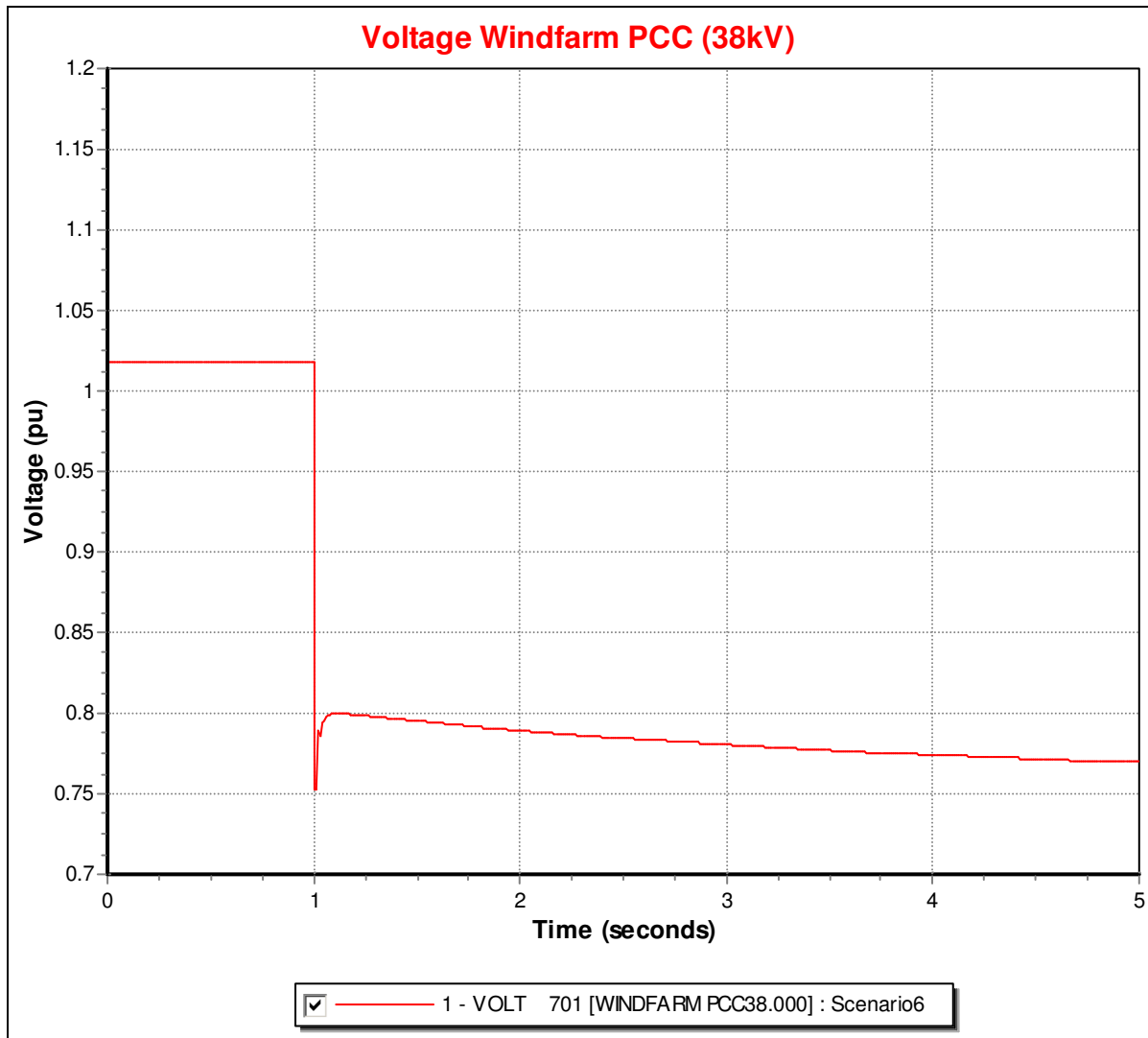

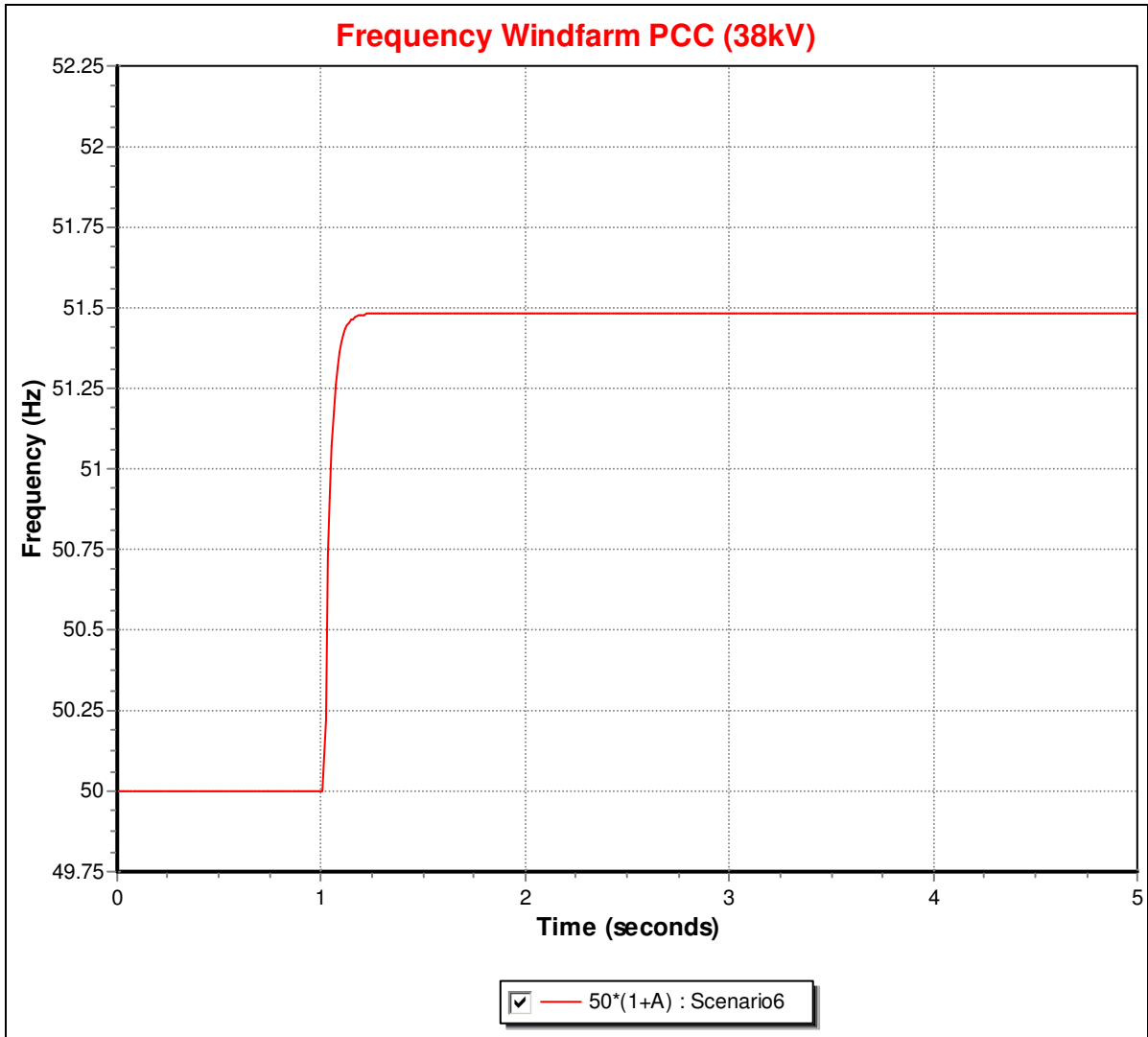

Winter Peak Results

Results: Winter Peak

Wind Farm Output: 15%

Existing Windfarm Interface Protection Trip: Yes

Proposed Windfarm Interface Protection Trip: Yes

Comments: Simulation Unstable

Results: Winter Peak

Wind Farm Output: 100%

Existing Windfarm Interface Protection Trip: Yes

Proposed Windfarm Interface Protection Trip: Yes

Comments: Simulation Unstable

Scenario 7: Loss of 110/38kV substation + 38kV feeder (Substation F – Wind Farm)

Details:

Results: Summer Night Valley

Wind Farm Output: 15%

Existing Windfarm Interface Protection Trip: Yes

Proposed Windfarm Interface Protection Trip: Yes

Comments: Simulation Stable

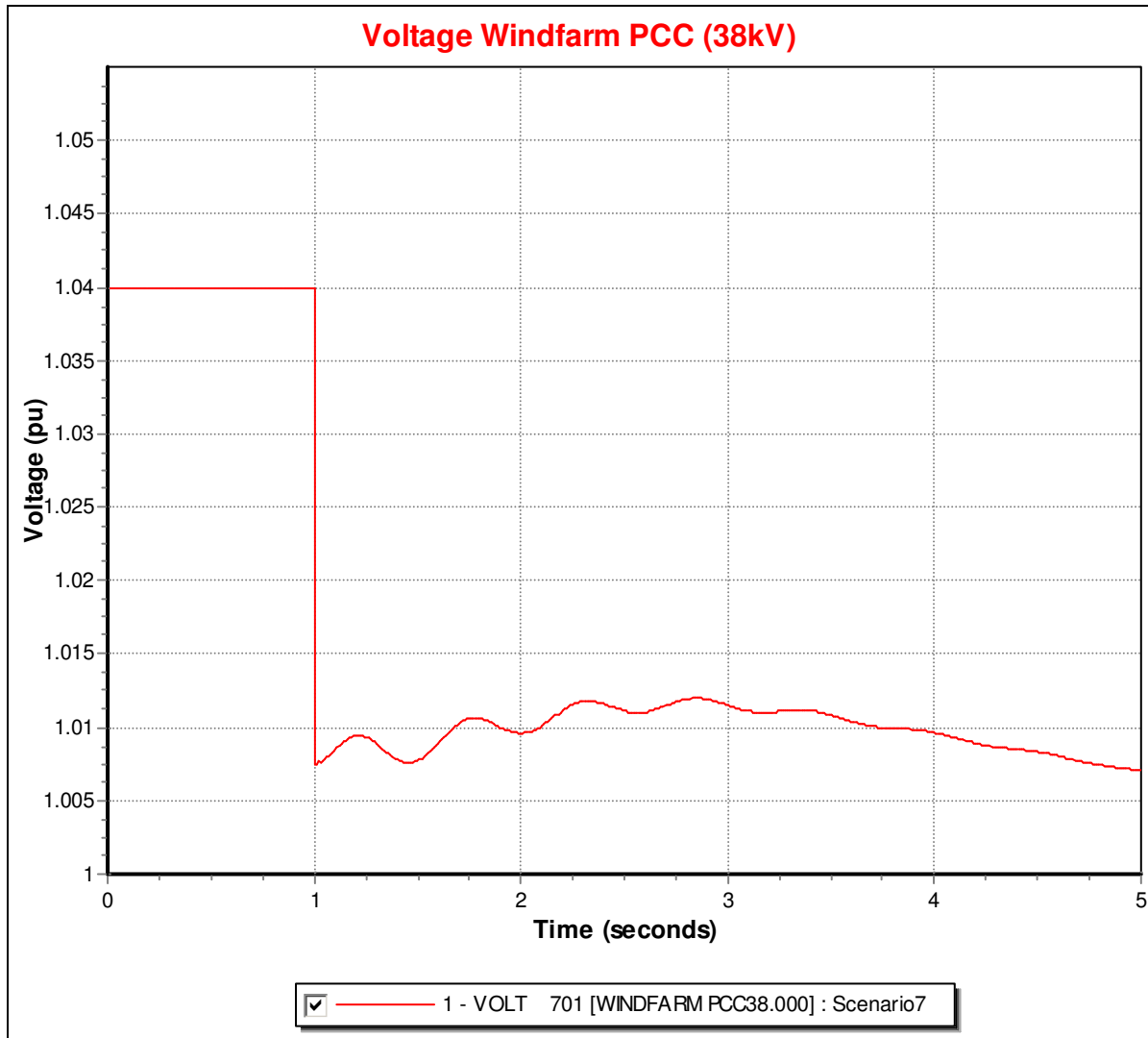

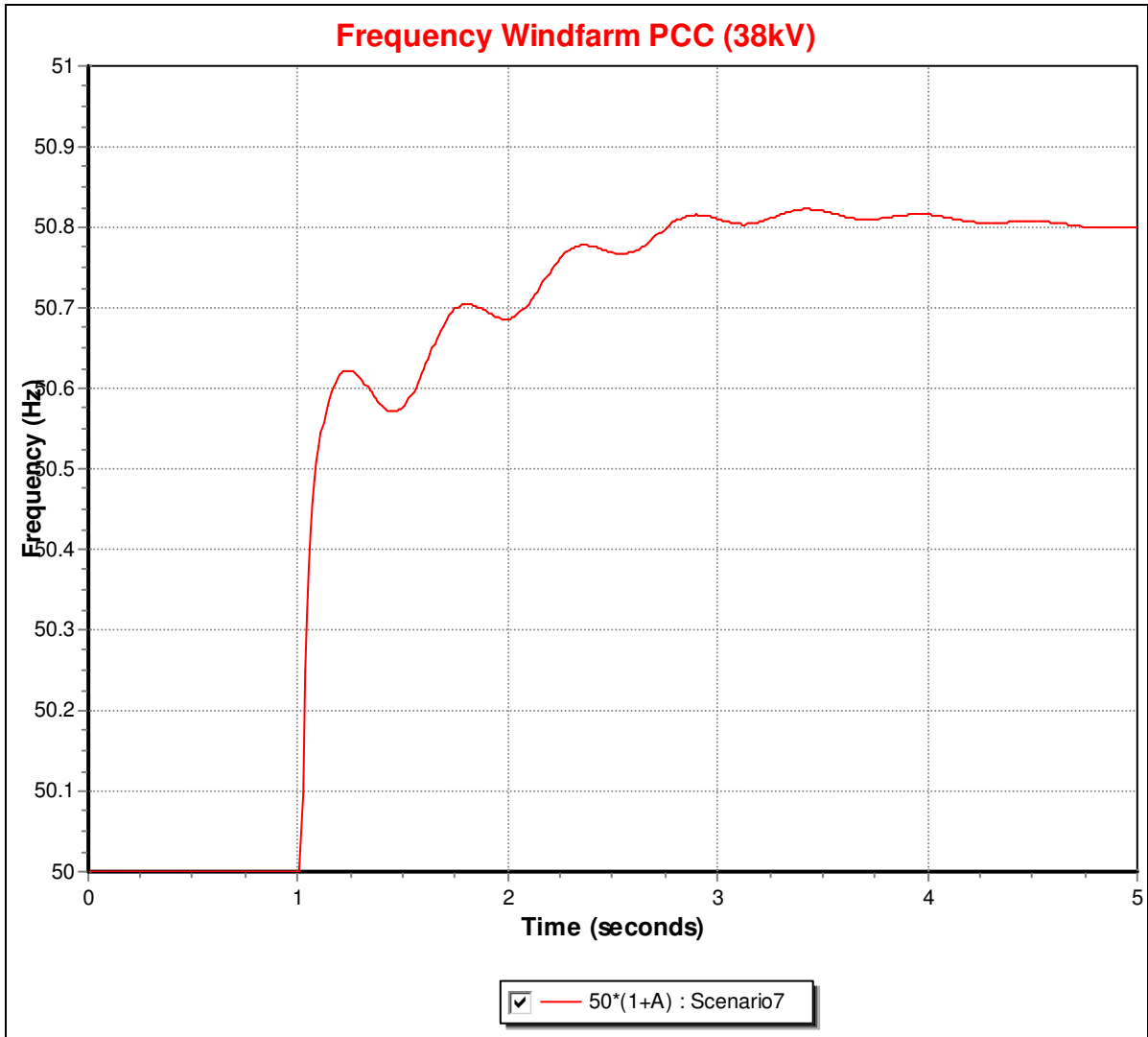

Details:

Results: Summer Night Valley

Wind Farm Output: 100%

Existing Windfarm Interface Protection Trip: Yes

Proposed Windfarm Interface Protection Trip: Yes

Comments: Simulation Stable

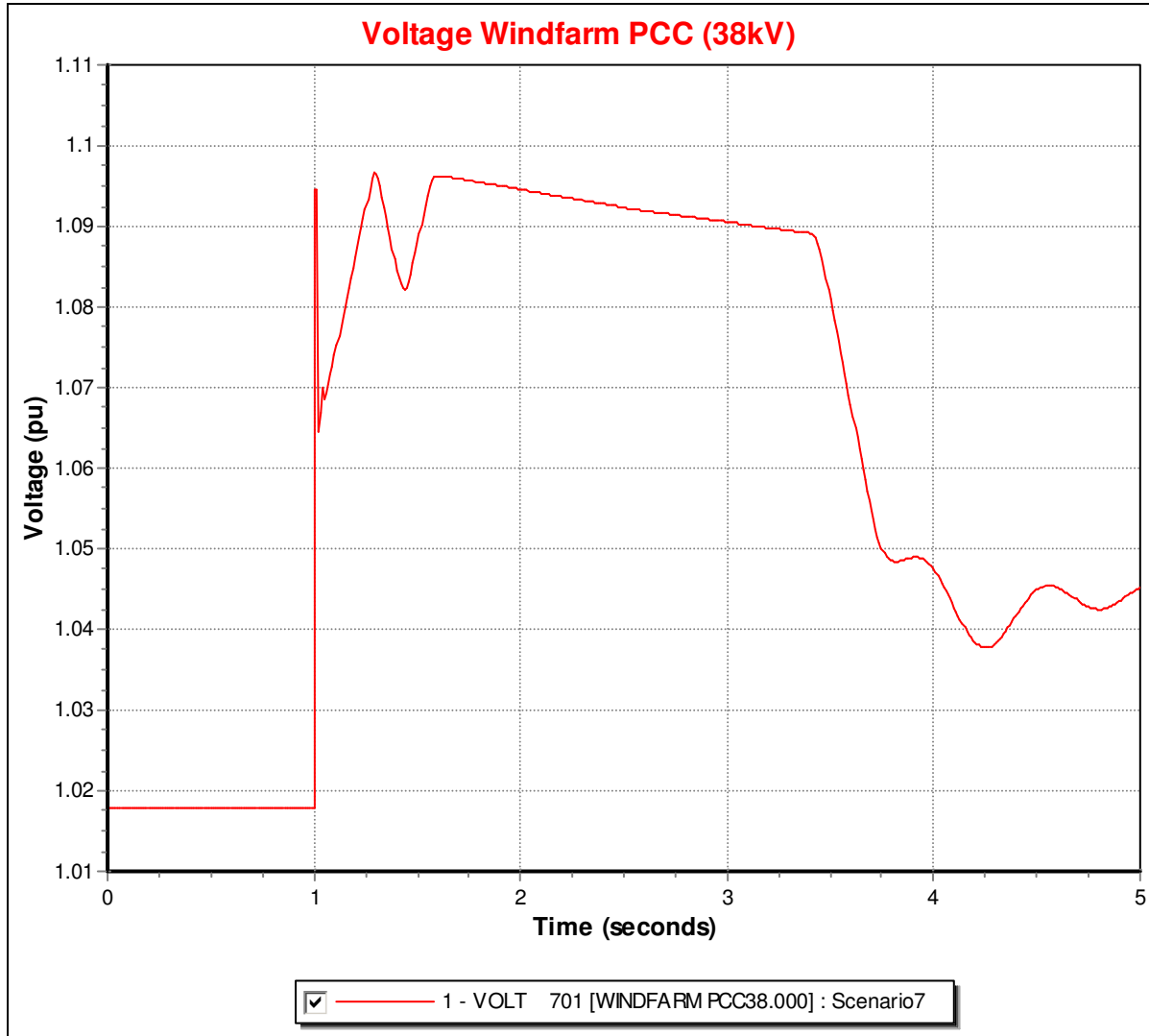

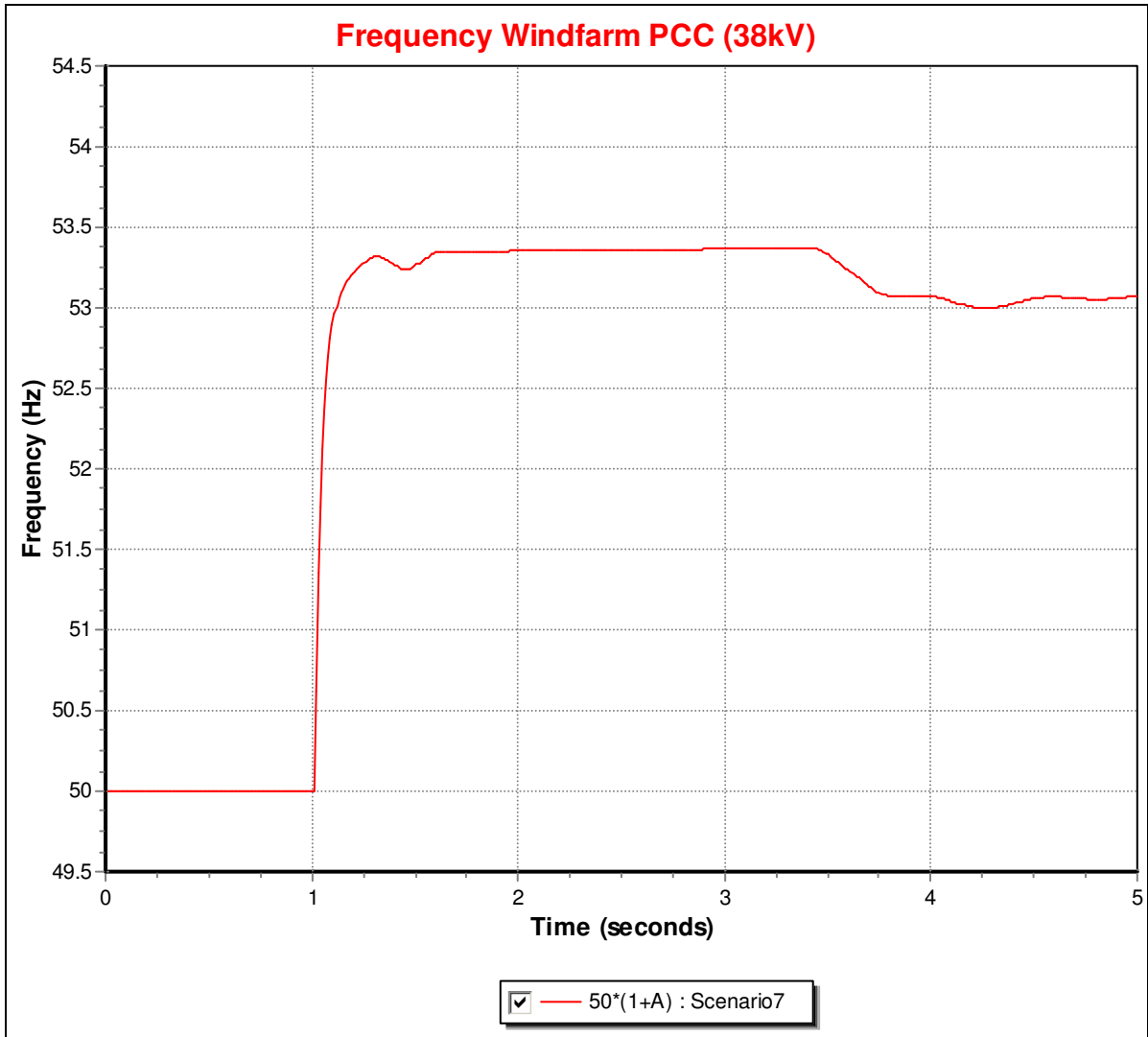

Results: Winter Peak
Wind Farm Output: 15%
Existing Windfarm Interface Protection Trip: Yes
Proposed Windfarm Interface Protection Trip: Yes
Comments: Simulation Stable

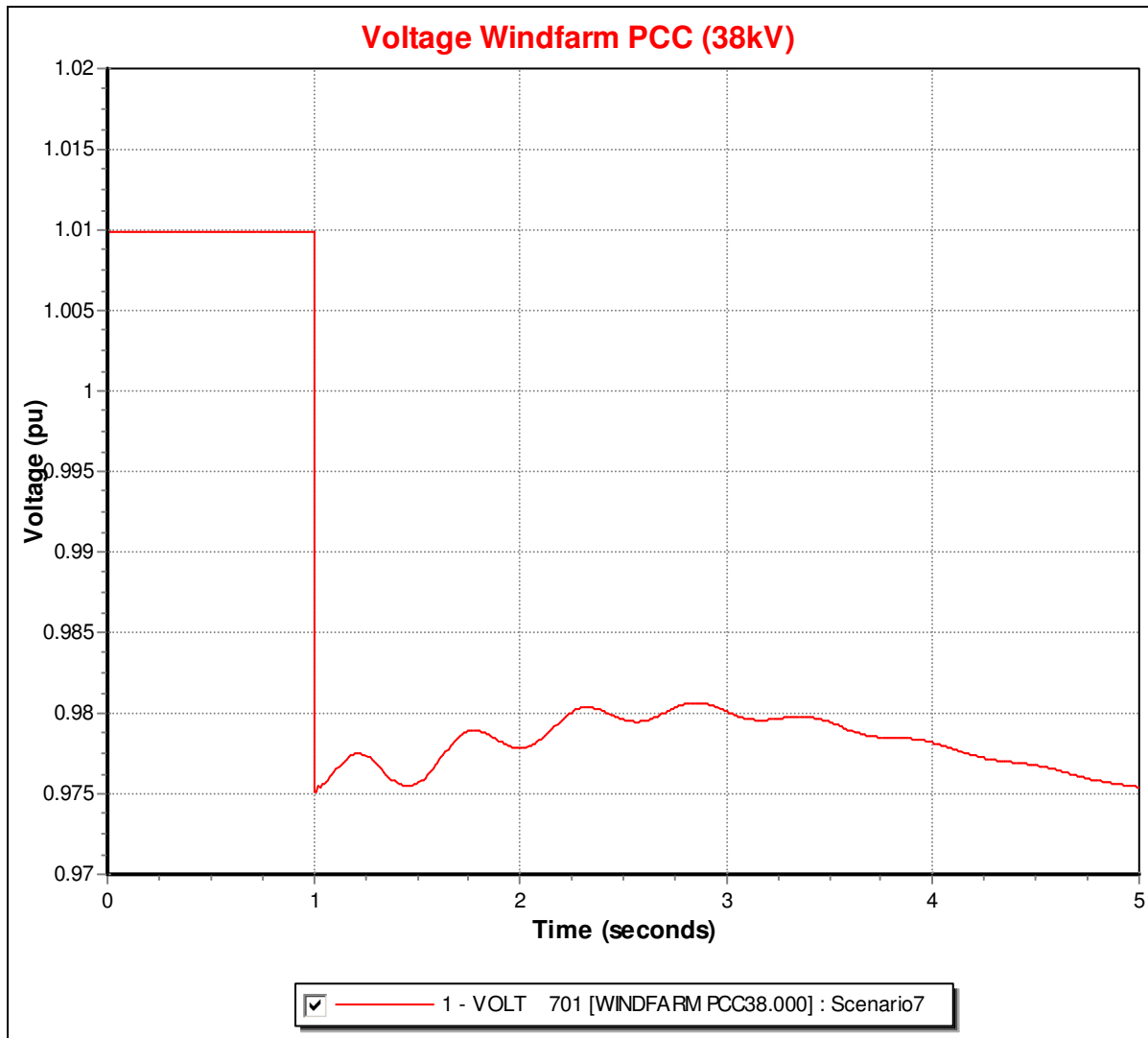

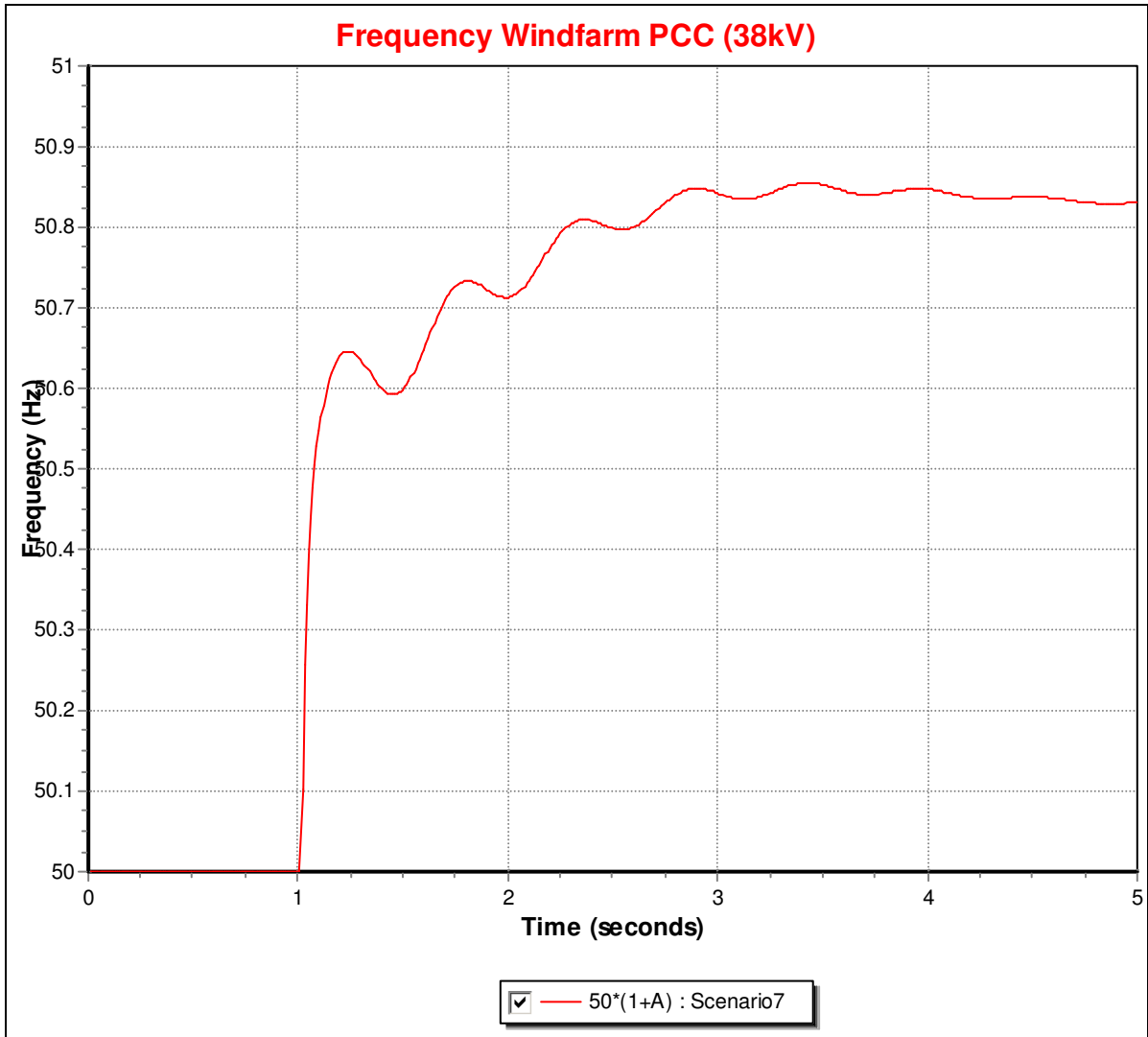

Results: Winter Peak
Wind Farm Output: 100%
Existing Windfarm Interface Protection Trip: Yes
Proposed Windfarm Interface Protection Trip: Yes
Comments: Simulation Stable

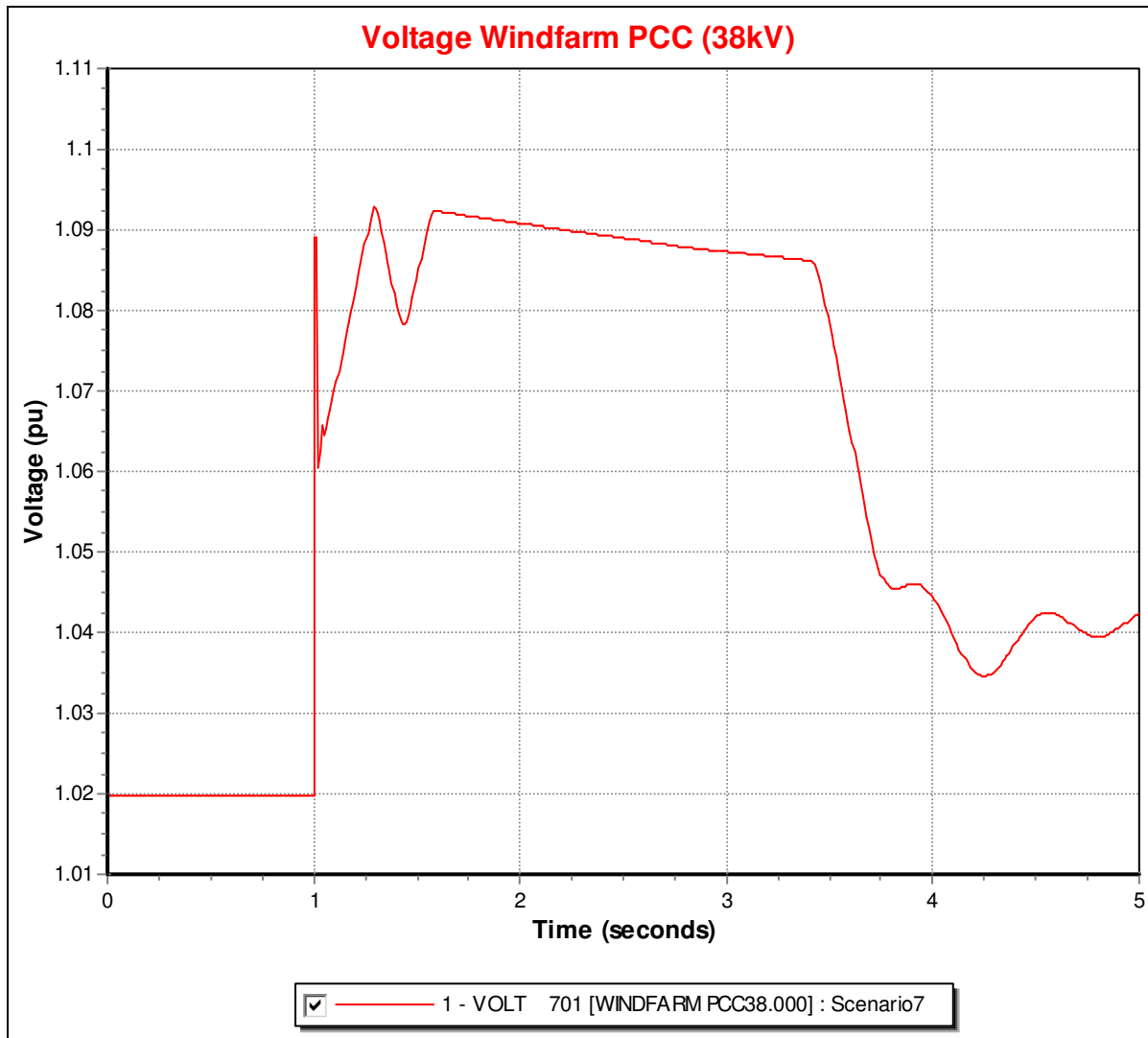

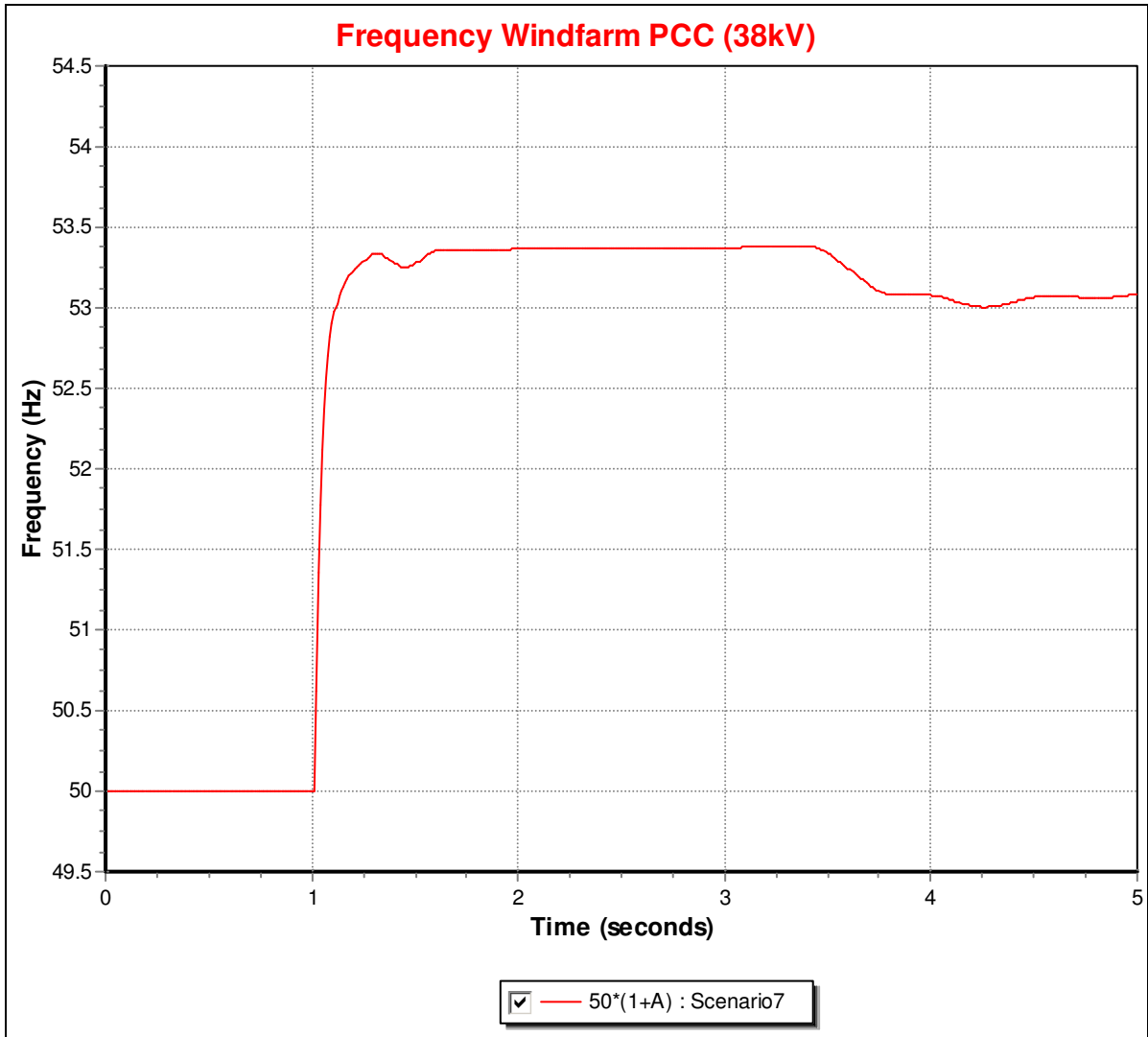

J PSS/E Relay Documentation

P.25 FRQDCA/FRQTPA

Under/Over Frequency Generator Bus Disconnection Relay Under/Over Frequency Generator Trip Relay

This model is located at system bus #_____ IBUS
 machine #_____ IM
 This model uses CONs starting with #_____ J
 and VARs starting with #_____ K
 and ICONs starting with #_____ I

CONs	#	Value	Description
J			FL, Lower frequency threshold (pu)
J+1			FU, Upper frequency threshold (pu)
J+2			TP, Relay pickup time (sec)
J+3			TB, Breaker time (sec)

VARs	#	Description	ICONs	#	Description
K		Timer memory	I		Bus number where frequency is monitored
			I+1		Bus number of generator bus where relay is located
			I+2		Generator ID
			I+3		Delay flag
			I+4		Timeout flag
			I+5		Timer status

Note: ICONs (I+3) through (I+5) are control flags that are not to be changed by the user.

```
0 'USRMDL' 0 'FRQDCA' 0 2 6 4 0 1 ICON(I) ICON(I+1) 'ICON(I+2)' 0 0 0
CONs from (J) to (J+3)/
```

or

```
0 'USRMDL' 0 'FRQTPA' 0 2 6 4 0 1 ICON(I) ICON(I+1) 'ICON(I+2)' 0 0 0
CONs from (J) to (J+3)/
```

Note: Model FRQDCA disconnects generator bus (i.e., disconnects all equipment attached to the generator bus).

Model FRQTPA disconnects generators only.

P.26 VTGDCA/VTGTPA

Under/Over Voltage Generator Bus Disconnection Relay Under/Over Voltage Generator Trip Relay

This model is located at system bus # _____ IBUS
 machine # _____ IM
 This model uses CONs starting with # _____ J
 and VARs starting with # _____ K
 and ICONs starting with # _____ I

CONs	#	Value	Description
J			VL, Lower voltage threshold (pu)
J+1			VU, Upper voltage threshold (pu)
J+2			TP, Relay pickup time (sec)
J+3			TB, Breaker time (sec)

VARs	#	Description	ICONs	#	Description
K		Timer memory	I		Bus number where voltage is monitored
			I+1		Bus number of generator bus where relay is located
			I+2		Generator ID
			I+3		Delay flag
			I+4		Timeout flag
			I+5		Timer status

Note: ICONs (I+3) through (I+5) are control flags that are not to be changed by the user.

```
0 'USRMDL' 0 'VTGDCA' 0 2 6 4 0 1 ICON(I) ICON(I+1) 'ICON(I+2)' 0 0 0
CONs from (J) to (J+3)/
```

or

```
0 'USRMDL' 0 'VTGTPA' 0 2 6 4 0 1 ICON(I) ICON(I+1) 'ICON(I+2)' 0 0 0
CONs from (J) to (J+3)/
```

Note: Model VTGDCA disconnects generator bus (i.e., disconnects all equipment attached to the generator bus).

Model VTGTPA disconnects generators only.

K ROCOF Protection Operation

Scenario 1 Loss of 110/38kV substation

Summer Valley 15% Wind Farm Output

ROCOF PROTECTION	
Pload	23.5
Pgen	3
H	4.95
MW MACHINE	3
ROCOF	34.51178451
FREQUENCY	50

100% Wind Farm Output

ROCOF PROTECTION	
Pload	23.5
Pgen	30
H	4.95
MW MACHINE	30
ROCOF	-1.094276094
FREQUENCY	50

Winter Peak 15% Wind Farm Output

ROCOF PROTECTION	
Pload	48.3
Pgen	3
H	4.95
MW MACHINE	3
ROCOF	76.26262626
FREQUENCY	50

100% Wind Farm Output

ROCOF PROTECTION	
Pload	48.3
Pgen	30
H	4.95
MW MACHINE	30
ROCOF	3.080808081
FREQUENCY	50

Scenario 2

Loss of 110/38kV substation + Feeder B - C

Summer Valley 15% Wind Farm Output

ROCOF PROTECTION	
Pload	20.6
Pgen	3
H	4.95
MW MACHINE	3
ROCOF	29.62962963
FREQUENCY	50

100% Wind Farm Output

ROCOF PROTECTION	
Pload	20.6
Pgen	30
H	4.95
MW MACHINE	30
ROCOF	-1.582491582
FREQUENCY	50

Winter Peak 15% Wind Farm Output

ROCOF PROTECTION	
Pload	42.6
Pgen	3
H	4.95
MW MACHINE	3
ROCOF	66.66666667
FREQUENCY	50

100% Wind Farm Output

ROCOF PROTECTION	
Pload	42.6
Pgen	30
H	4.95
MW MACHINE	30
ROCOF	2.121212121
FREQUENCY	50

Scenario 3**Loss of 110/38kV substation + Feeder B****Summer Valley 15% Wind Farm Output**

ROCOF PROTECTION	
Pload	17.5
Pgen	3
H	4.95
MW MACHINE	3
ROCOF	24.41077441
FREQUENCY	50

100% Wind Farm Output

ROCOF PROTECTION	
Pload	17.5
Pgen	30
H	4.95
MW MACHINE	30
ROCOF	-2.104377104
FREQUENCY	50

Winter Peak 15% Wind Farm Output

ROCOF PROTECTION	
Pload	36.3
Pgen	3
H	4.95
MW MACHINE	3
ROCOF	56.06060606
FREQUENCY	50

100% Wind Farm Output

ROCOF PROTECTION	
Pload	36.3
Pgen	30
H	4.95
MW MACHINE	30
ROCOF	1.060606061
FREQUENCY	50

Scenario 4

Loss of 110/38kV substation + Feeder D

Summer Valley		15% Wind Farm Output	
ROCOF PROTECTION			
Pload		12.3	
Pgen		3	
H		4.95	
MW MACHINE		3	
ROCOF		15.65656566	
FREQUENCY		50	

		100% Wind Farm Output	
ROCOF PROTECTION			
Pload		12.3	
Pgen		30	
H		4.95	
MW MACHINE		30	
ROCOF		-2.97979798	
FREQUENCY		50	

Winter Peak		15% Wind Farm Output	
ROCOF PROTECTION			
Pload		24.8	
Pgen		3	
H		4.95	
MW MACHINE		3	
ROCOF		36.7003367	
FREQUENCY		50	

		100% Wind Farm Output	
ROCOF PROTECTION			
Pload		24.8	
Pgen		30	
H		4.95	
MW MACHINE		30	
ROCOF		-0.875420875	
FREQUENCY		50	

Scenario 5

Loss of 110/38kV substation + Feeder F

Summer Valley 15% Wind Farm Output

ROCOF PROTECTION	
Pload	6.4
Pgen	3
H	4.95
MW MACHINE	3
ROCOF	5.723905724
FREQUENCY	50

100% Wind Farm Output

ROCOF PROTECTION	
Pload	6.4
Pgen	30
H	4.95
MW MACHINE	30
ROCOF	-3.973063973
FREQUENCY	50

Winter Peak 15% Wind Farm Output

ROCOF PROTECTION	
Pload	12.8
Pgen	3
H	4.95
MW MACHINE	3
ROCOF	16.4983165
FREQUENCY	50

100% Wind Farm Output

ROCOF PROTECTION	
Pload	12.8
Pgen	30
H	4.95
MW MACHINE	30
ROCOF	-2.895622896
FREQUENCY	50

Scenario 6

Loss of 110/38kV substation + Feeder D - E

Summer Valley	15% Wind Farm Output
ROCOF PROTECTION	
Pload	19.1
Pgen	3
H	4.95
MW MACHINE	3
ROCOF	27.1043771
FREQUENCY	50

	100% Wind Farm Output
ROCOF PROTECTION	
Pload	19.1
Pgen	30
H	4.95
MW MACHINE	30
ROCOF	-1.835016835
FREQUENCY	50

Winter Peak	15% Wind Farm Output
ROCOF PROTECTION	
Pload	38.4
Pgen	3
H	4.95
MW MACHINE	3
ROCOF	59.5959596
FREQUENCY	50

	100% Wind Farm Output
ROCOF PROTECTION	
Pload	38.4
Pgen	30
H	4.95
MW MACHINE	30
ROCOF	1.414141414
FREQUENCY	50

Scenario 7

Loss of 110/38kV substation + Feeder F - Wind farm

Summer Valley		15% Wind Farm Output	
ROCOF PROTECTION			
Pload		0	
Pgen		3	
H		4.95	
MW MACHINE		3	
ROCOF		-5.050505051	
FREQUENCY		50	

		100% Wind Farm Output	
ROCOF PROTECTION			
Pload		0	
Pgen		30	
H		4.95	
MW MACHINE		30	
ROCOF		-5.050505051	
FREQUENCY		50	

Winter Peak		15% Wind Farm Output	
ROCOF PROTECTION			
Pload		0	
Pgen		3	
H		4.95	
MW MACHINE		3	
ROCOF		-5.050505051	
FREQUENCY		50	

		100% Wind Farm Output	
ROCOF PROTECTION			
Pload		0	
Pgen		30	
H		4.95	
MW MACHINE		30	
ROCOF		-5.050505051	
FREQUENCY		50	