

2004

Measurement of the Frequency Response of Clinical Gas Analysers

Kabita Shakya

School of Informatics and Engineering, Institute of Technology Blanchardstown.

Catherine Deegan

School of Informatics and Engineering, Institute of Technology Blanchardstown.

Fran Hegarty

Department of Medical Physics and BioEngineering, St James's Hospital, Dublin 2.

Charles Markham

Department of Computer Science, National University of Ireland, Maynooth.

Follow this and additional works at: <https://arrow.tudublin.ie/itbj>



Part of the [Biomedical Engineering and Bioengineering Commons](#)

Recommended Citation

Shakya, Kabita; Deegan, Catherine; Hegarty, Fran; and Markham, Charles (2004) "Measurement of the Frequency Response of Clinical Gas Analysers," *The ITB Journal*: Vol. 5: Iss. 1, Article 24.

doi:10.21427/D7NJ0M

Available at: <https://arrow.tudublin.ie/itbj/vol5/iss1/24>

This Article is brought to you for free and open access by the Journals Published Through Arrow at ARROW@TU Dublin. It has been accepted for inclusion in The ITB Journal by an authorized administrator of ARROW@TU Dublin. For more information, please contact yvonne.desmond@tudublin.ie, arrow.admin@tudublin.ie, brian.widdis@tudublin.ie.



This work is licensed under a [Creative Commons Attribution-NonCommercial-Share Alike 3.0 License](#)

Measurement of the Frequency Response of Clinical Gas Analysers

**Kabita Shakya¹, Catherine Deegan¹,
Fran Hegarty², Charles Markham³**

¹School of Informatics and Engineering, Institute of Technology Blanchardstown.

²Department of Medical Physics and BioEngineering, St James's Hospital, Dublin 2.

³Department of Computer Science, National University of Ireland, Maynooth.

Abstract

A technique for the time and frequency response measurement of clinical CO₂ analysers has been established. The time and frequency response of several analyser systems has been determined. This paper presents the case for the routine measurement of the dynamic performance of such systems in the context of their application in high-frequency ventilation schemes. The importance of these measurements has been demonstrated in the comparison of older and newer systems in the sense that older systems demonstrate significant deterioration in performance. In the context of the use of capnographs in life-support systems, it is essential to measure and monitor the dynamic performance of such systems to ensure the appropriate monitoring of ventilation schemes. All of the units so far analysed cannot be used for high-frequency and/or paediatric ventilation schemes of over 80 breaths per minute.

Keywords: Mechanical ventilation, respirator, ETCO₂ capnogram, , capnography, capnometer , BPM, ventilation rate , frequency response , dynamic response, rise time, sensor response time, transit time, total system response time .

Introduction

In health care units, patients in acute illness and surgery are supported by mechanical ventilation. Mechanical ventilation is the process by which the patient's respiratory function is artificially supported using a respirator. The patient is monitored for several ventilatory parameters during this period, as the adequacy of ventilation must be ensured. End tidal CO₂ (EtCO₂) is one of them. EtCO₂ is the partial pressure or maximal concentration of carbon dioxide (CO₂) at the end of an exhaled breath, which is expressed as a percentage of CO₂ or mmHg. Measurement and monitoring of this parameter assists with appropriate ventilation of the patient as under normal respiration, a person will inhale 0% and exhale up to 5% CO₂ in any one breath.

Capnography is the method that traces out expired CO₂ versus time graphically and measures EtCO₂. The measuring device is called a capnometer (if it displays numerical value only) and capnograph (if it displays graphically as well). The waveform displayed by the capnograph is called a capnogram. A sketch of a typical capnogram is shown in Figure 6(a), with an actual capnograph trace shown in Figure 6 (b).

Determination of EtCO₂ concentration is important as this value of CO₂ (in mmHg or percentage) is accepted to be the equal to the CO₂ content of the blood and is an indicator of how efficiently CO₂ is cleared from the blood supply .

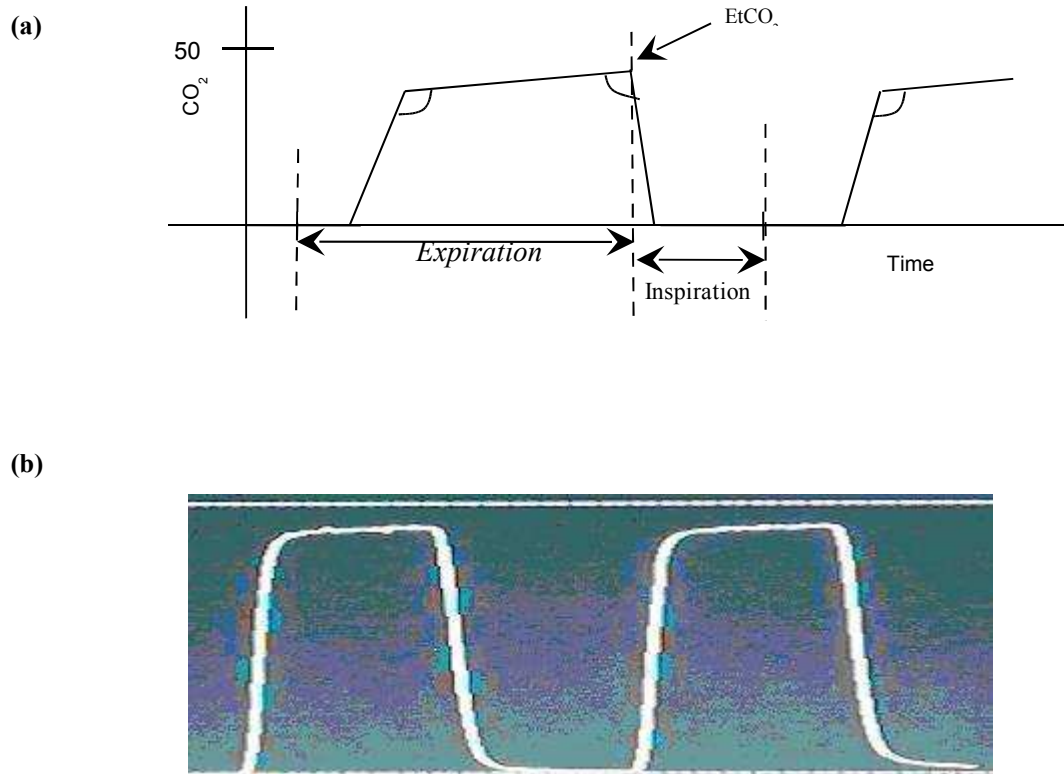

Figure 6 (a) : Normal capnogram of a healthy human. (b) Capnograph Trace

There are three basic CO₂ gas-sampling technologies for EtCO₂ analysis. They are sidestream, mainstream and microstream technologies.

Sidestream technology is the most common . In this technology, the gas sample is aspirated from the ventilator circuit and the analysis occurs away from the ventilator circuit. A pump and lengthy tubing is used to aspirate the sample from the exhaled breath.

In mainstream technology, the CO₂ sensor is positioned directly at the patient's airway. The response time is thus faster and mixing of CO₂ with fresh gas is prevented to a greater extent. However, in this case, the sampling device is bulky and difficult to keep in place so this technology is not usually the first choice for general use.

Microstream technology is comparatively a new technology. It employs a unique, laser-based technology called molecular correlation spectroscopy (MCS™) as the infrared emission source. The Microstream® emitter radiates a focused beam of infrared energy characterized by the

narrow region (0.15 μm wide) of the spectrum precisely matching the absorption spectrum of CO_2 .

1.1 The End Tidal CO_2 Analyser

The end tidal CO_2 analyser detects the CO_2 concentration in the patients' expired air. The most popular technique for this is infrared technology. Infrared technology uses absorbance spectroscopy in which the loss of electromagnetic energy is measured after the energy interacts the sample under study.

CO_2 selectively absorbs infrared light energy at a wavelength of 4.26 μm . Since the amount of light absorbed is proportional to the concentration of the absorbing molecules, the concentration of CO_2 in the exhaled breath is determined by passing that wavelength of infrared light through the sample and comparing the amount of energy absorbed with the amount absorbed by a sample that contains no CO_2 . The result is expressed either in terms of mmHg or as a percentage of CO_2 ($^3\text{PCO}_2/^4\text{P}_{\text{atm}}$). Analyser using infrared technology is called Infrared spectrograph and is more compact and less expensive than other technologies in use.

EtCO_2 analysers are used in ventilation units, some of them combined with ECG (electrocardiography) or pulse oximetry units and sometimes also as a separate unit (in handheld capnographs).

1.2 Ventilation rate

Ventilation rate is also called respiration /breathing rate. It is given as Breaths per Minute (BPM). The reciprocal of ventilation rate is Ventilation Frequency. A typical individual at rest takes about 12-18 BPM (0.2Hz-0.33Hz), but this rate can triple during hard work (0.3Hz – 0.99Hz). Generally, 15 BPM (0.25Hz.) to 30 BPM (0.5Hz) is considered to be normal in an adult. However, an infant has a higher ventilatory rate (up to 120 BPM i.e. 2Hz) and smaller tidal volume, as a low volume of CO_2 is produced. Tidal volume is the volume of air inspired and expired with each normal breath.

The ventilation frequency is said to be 'high frequency' when it is greater than 2 Hz (120 BPM) and it is said to be 'low frequency' if it is below 0.25 Hz (15 BPM).

³ Partial pressure of CO_2

⁴ Standard (Normal) atmospheric pressure (equivalent to 760mmHg)

1.3 Calibration of (CO₂) Gas Analysers

The most straightforward type of calibration for gas analysers is a 'static' calibration technique in which a known value is input to the system under calibration and the system output is recorded. The static calibration method (also called two-point method) is the current technique for calibrating EtCO₂ analysers. This method features 'zero' calibration to ambient air and 'span' calibration to a self-contained 5% (i.e. 38 mmHg) CO₂ calibration gas. Though the static method is widely accepted as a valid technique for such gas analysers, it is insufficient for describing the dynamic behavior of the analyser, which is the real time event. Dynamic calibration determines the relationship between an input of known dynamic behavior and the (time-varying) measurement system output. When a time dependent variable (in this case, CO₂ concentration) is to be measured, a dynamic calibration should be performed.

The need to measure the time response of these devices has been established by several authors -, however, to date, no techniques for or measurements of the frequency response of these analysers have been established.

Frequency and Dynamic Response Measurement of an ETCO₂ Analyser

In determining the frequency response of the EtCO₂ analyser, the maximum CO₂ concentration is considered as the amplitude value while the oscillation frequency of the CO₂ signal (the simulated ventilation frequency) is considered the frequency.

Figure 7 shows a sketch of a segment of a typical waveform obtained from the EtCO₂ analyser of a sidestream capnograph. The response time t_{response} is the total of ⁵ t_1 and ⁶ t_2 where t_1 (transit time) is the time taken for the sample gas to move from the point of sampling to the point of measurement while t_2 (sensor response time) is time taken for the waveform to reach 70% of its final value ($t_2 = t_{70}$) from 10% of its final value. t_2 can also be taken as the time taken for the waveform to reach 90% of the final value ($t_2 = t_{90}$) from 10% of its final value. t_{70} is generally used instead of t_{90} because the 70% point is on a steeper part of the response curve and therefore less dependent on noise. For all practical purposes t_{90} is twice the value of t_{70} . The value t_{70} can also be taken equal to the time constant (t_{70} is 0% to 63% of the final value). In this paper t_{70} is taken as 0 to 70% of its final value.

The t_1 value generally accounts for about 89% or more of the t_{response} . Generally, t_1 and t_2 are not defined in manufacturers' specifications but these factors should be defined and specified as a

⁵ transit time also called transport delay (TD)

⁶ Sensor response time also called rise time (RT), defined as t_{70} (0 to 70%) or t_{70} (10 to 70%) or t_{90} (0 to 90%) or t_{90} (10 to 90%) - or sometimes also as time constant (τ , 0 to 63%). This paper defines RT as t_{70} (0 to 70%)

long t_1 can prolong t_2 which can result in the underestimation of EtCO₂ during high frequency ventilation. Also, a long t_1 may introduce an unacceptable delay in the total response time of the analyser .

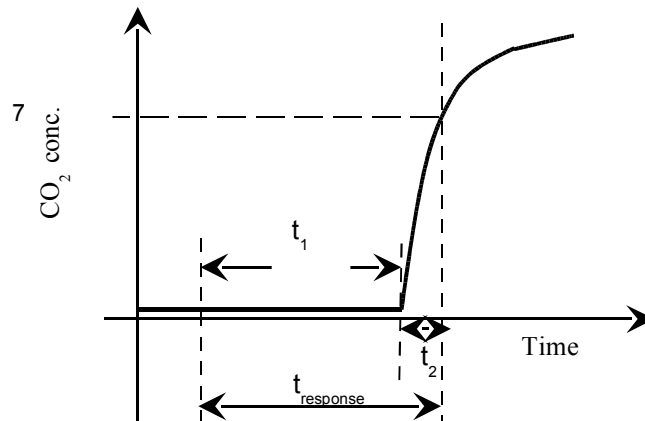

Figure 7: Sketch of a typical EtCO₂ waveform showing the transit time (t_1), sensor response time (t_2) and the total response time (t_{response}) of the sensor system.

Manufacturers generally report only the rise time (t_2) of their capnographs in the instrument manuals. In fact, the most accurate measurement of capnograph response is the total response time (sensor response time plus transit time). This response time should always be known before attempting to use the capnograph system on a non-standard (i.e. high frequency) ventilation circuit to ensure that the capnometer can accurately track the patient's respiration cycle. To date no technique for measuring this parameter has been routinely used in the clinical setting.

In this paper, the t_1 , t_2 and t_{response} values and the frequency response for a small range of capnograph systems has been presented. The techniques and analysis presented in this paper are now in use in a clinical engineering department as part of the commissioning process of new monitoring equipment.

Experimental Technique

An experimental system was developed to emulate the normal breathing patterns of a ventilated patient. The experimental setup consists basically of a CO₂ simulator and a capnograph system. The CO₂ simulator comprises of a 5% CO₂ gas cylinder, air cylinder, pressures regulators, gas valves and the connectors. The CO₂ output is finally delivered to the capnograph. The gas valves are electronically controlled via a computer program in order to simulate the respiration process. Air is used in the system to flush residual CO₂ from the valves. A block diagram of the system is shown in Figure 8. A more detailed report on this system may be found in .

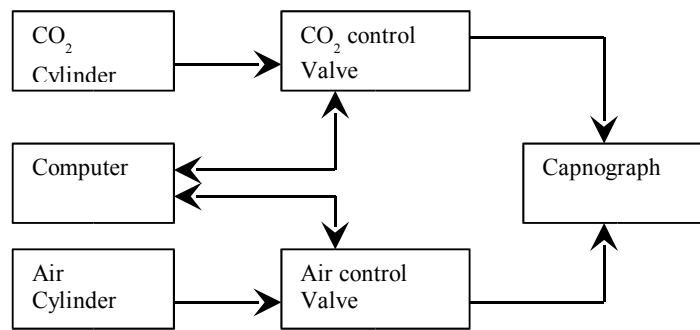

Figure 8 : Block diagram of the experimental system

Data collection from these types of monitors can be problematic as usually there is no means of accessing the raw data electronically. Data acquisition was achieved using a digital video camera to capture the waveforms as they appeared in real-time on the screen. The image data was then processed to extract the waveform data. A sample of data acquired in this manner is shown in Figure 9.

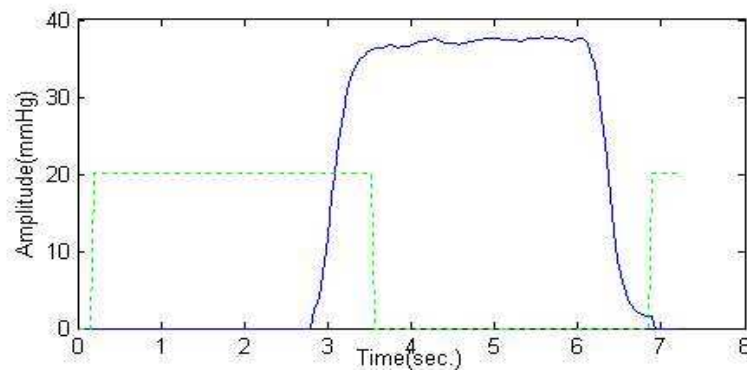

Figure 9: Single waveform (continuous line). The dashed line indicates the on/off time for the CO₂ signal.

Commissioning of Clinical Monitoring Equipment

Before new equipment is used by medical professionals, it must first be submitted to a series of tests to verify its safe and accurate operation. This commissioning procedure is one of the most important procedures carried out by the clinical engineer. The process includes visual inspection, safety tests and functional examination.

To date, the commissioning procedure specifically for CO₂ analysers has included the standard electrical safety tests and a static calibration as well as the fall time measurement of a CO₂ gas signal .

The techniques and measurements developed here will add to the functional verification procedures for the CO₂ analysers of gas monitors. This will allow the determination of the optimum working frequency range of the analyser and also enables sensor response time calculation (for checking against the manufacturers' specification), transit time calculation and hence total response time of the analyser as described in Section .

Results

Frequency Response Measurement of the Drager Capnolog™ System

The experimental system described was tested on a decommissioned capnography system [11]. The frequency response of the Drager Capnolog EtCO₂ analyser is shown in Figure 10. It is clear from this figure that the response of the analyser is compromised at respiration frequencies over 1 Hz.

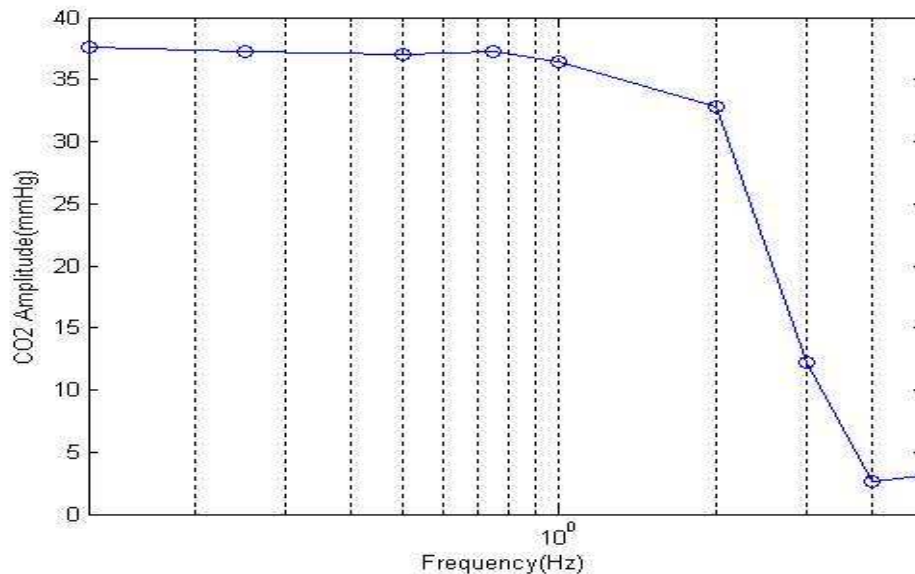

Figure 10: Amplitude versus Frequency curve for the Capnolog EtCO₂ analyser

The transit time (t_t) was found to be 2 sec and the sensor response time (t_s) was found to be 520 ms ($t_{10\%}$ to $t_{90\%}$) giving a total response time of 2528ms (including t_0 to 10%).

Frequency Response of the Datex Ohmeda Capnography System

This project has been undertaken in collaboration with the Medical Physics and BioEngineering Department at St. James's hospital. A unique opportunity to investigate and verify several identical capnographs arose when a new set were acquired and commissioned. Result from all sixteen analysers is shown in Figure 11, and in Table 1. The frequency response for all M-CAiO compact Airway modules is compared in Figure 11. The frequency responses for all Single width Airway Module, M-miniC are compared in . It is clear from Figure 11 and that,

as expected, the frequency responses are well correlated in all analysers. A point to note about this data is that the data shown in indicate a maximum CO₂ signal of 35 mmHg. Of all the analysers tested, minis could not display a full-scale signal. For this reason, it is likely that

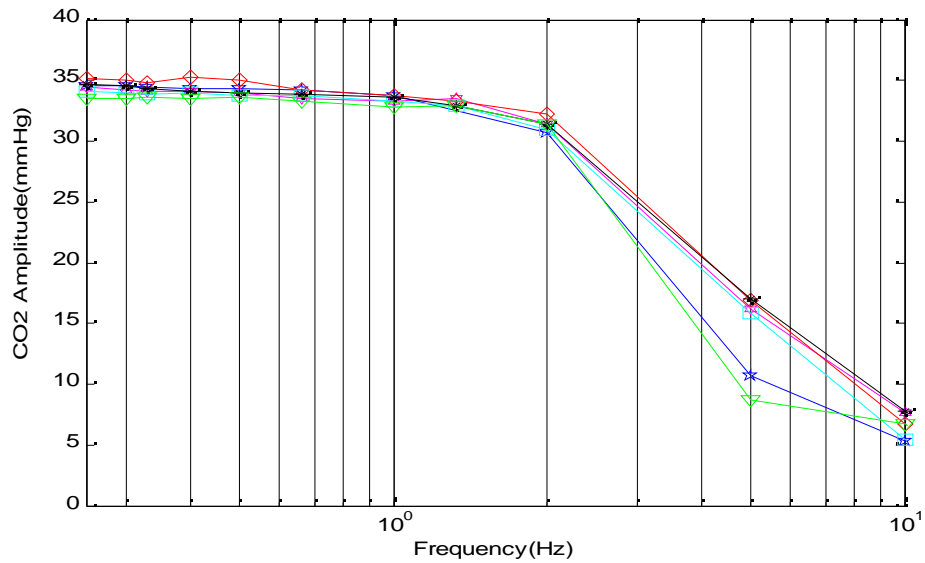

these analysers would fail the commissioning process and be returned for manufacturer calibration or it is possible that the suction rate of these analysers is higher than that of the MCIOs and these allow the mixing of air with the 5% CO₂ sample.

Figure 11: Frequency response for Datex Ohmeda (Single width Airway module, M-miniC)

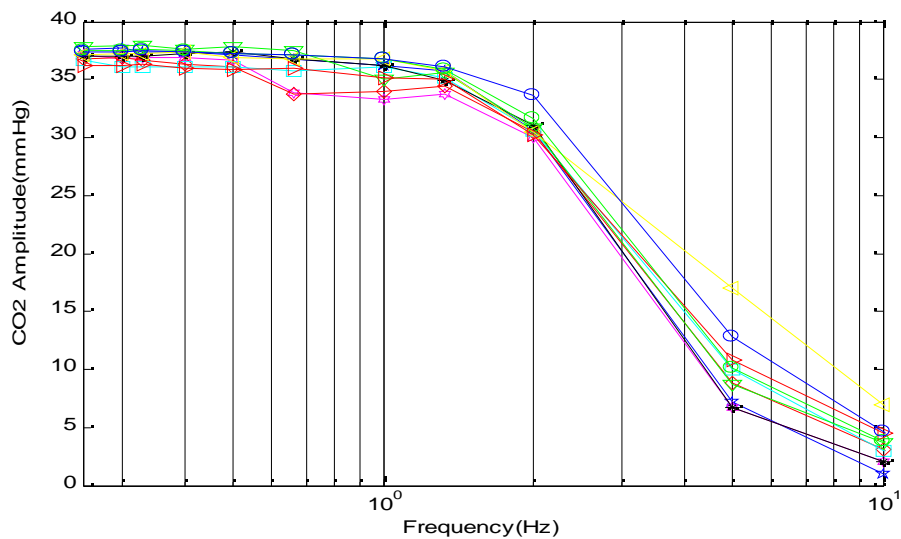

Figure 12: Frequency response of 6 capnographs (Datex Ohmeda, Compact Airway Module, M-CaiO and the single-width Airway Module, M-miniC)

The time responses for these analysers are shown in Table 1. The response time for the ‘mini-C’ module indicates a faster response time to the same signal. This is in accordance with the manufacturer’s specifications for the rise time (t_r). It is clear from this table that measurement of the

t_1 parameter is an important factor when considering a device's time response, reporting the rise time alone is clearly misleading for a sidestream type analyser as a relatively long delay is unavoidable due to the nature of the device itself.

Analyser units	Type	t_1 transit time	t_2 rise time	t_{response}
A	M-CAiO compact Airway module	2.64	0.36	3
B	M-CAiO compact Airway module	2.56	0.36	2.92
C	M-CAiO compact Airway module	2.72	0.36	3.08
D	M-CAiO compact Airway module	2.68	0.36	3.04
E	Single width Airway Module,M-miniC	2.28	0.28	2.56
F	M-CAiO compact Airway module	2.64	0.36	3
G	M-CAiO compact Airway module	2.6	0.4	3
H	M-CAiO compact Airway module	2.64	0.36	3
I	M-CAiO compact Airway module	2.48	0.36	2.84
J	M-CAiO compact Airway module	2.72	0.4	3.12
K	Single width Airway Module,M-miniC	2.28	0.32	2.6
L	Single width Airway Module,M-miniC	2.28	0.32	2.6
M	Single width Airway Module,M-miniC	2.32	0.32	2.64
N	Single width Airway Module,M-miniC	2.32	0.28	2.6
O	Single width Airway Module,M-miniC	2.28	0.32	2.6
P	M-CAiO compact Airway module	2.72	0.32	3.04

Table 1 : Time responses for six different ETCO_2 analysers.

Discussion and Conclusion

For the *Drager Capnolog* system, the working frequency range is from 0.125 Hertz to 1 Hertz i.e. it can operate for Respiratory Rates (RR) from 7.5 BPM to 60 BPM. It may not give satisfactory performance for RR greater than 60 BPM. The manufacturer's quoted respiratory rate in this case is 2-99BPM. Similarly, the sensor response time (t_r) was determined to be 520 ms ($t_{10\%}$ to $t_{90\%}$). This does not agree with the manufacturer's specified response time of 200 ms (10-90% at 200ml/min) . The transit time is not specified in the manufacturer's specification sheet though it is mentioned at one point that the gas takes approximately 1 second to reach the sensor. The measured transit time (t_t) was 2 seconds in this experiment. At this stage it is important to note that the poor performance of this analyser could be due to its age (approximately twenty years) and that it is possible that the analyser did perform as per manufacturer's specifications when first in use. The primary observation here with this system is that it is essential to monitor the performance of such analysers as drift away from the specified performance is to be expected. Frequency and time response data with the six new units were presented in Figure 11, and Table 1 for a 3.6 metre sampling line. For the M-CAiO unit, the manufacturer has quoted total system response time as 2.9 seconds with a 3 metre sampling line, including the sampling delay and⁷rise time. The CO_2 measurement rise time is quoted as <400 ms but it is not specified whether the

⁷ sensor response time is also called rise time (= t_r , 0% to 70% of final value)

value (of rise time) corresponds to t_{70} or t_{90} and that how the rise time is defined by them. It is assumed that the value corresponds to t_{70} (0 to 70%). Experiments are performed with 3.6 metre sampling tube so we can conclude that this type of analyser performs within the manufacturer's specification.

For the single-width Airway Module, M-miniC, the rise time is found to be 0.28 seconds, the transit time as 2.28 seconds and the total system response time as 2.56 seconds for a 3.6 metre sampling line. The manufacturer's specified total system response time is 2.4 seconds with a 3 metre sampling line. This time includes the sampling delay and rise time (specified as <300ms). In this case also, the rise time is not specified so it is assumed that the value corresponds to t_{70} (0 to 70%). Hence it may be concluded that this type of capnograph is also operating within the manufacturer's specified time response. However, as reported in section , the maximum signal response of this system was less than 38mmHg and so these particular units could possibly fail the complete commissioning procedure as a full scale signal is desirable for accurate ventilation monitoring. From the frequency response curves it is clear that the frequency response deteriorates over 1.33 Hz for both type of analysers. Hence it can be concluded that both of the units can function properly up to 80 breaths per minute (BPM) The manufacturer specifies 4-80 BPM for the single-width Airway module and 4-60 BPM for the M-miniC. So both of these modules are operating within specification.

In conclusion, a technique for the time and frequency response measurement of clinical CO₂ analysers has been established. The time and frequency response of old and new capnograph systems has been determined. The importance of these measurements has been demonstrated in the comparison of older and newer systems in the sense that the older system has been shown to be operating well outside specification. In the context of the use of capnographs in life-support systems, it is essential to measure and track the dynamic performance of such systems to ensure appropriate ventilation schemes are used in clinical applications.

References

- [1] Brenner JX, Westenskow DR: How the rise time of Carbon Dioxide analysers influences the accuracy of carbon dioxide measurements, *Br. J. Anaesth.* 1988; 61: 628-638
- [2] Breen Peter H, Mazumdar B, Skinner Sean C: Capnometer transport Delay- Measurement and Clinical Implications, *Anesth Analg* 1994; 78: 584 – 6
- [3] Fletcher R, Werner O, Nordstrom L, Jonson B: Sources of error and their correction in the measurement of Carbon dioxide elimination using the Siemens- Elema CO₂ analyzer, *Br. J. Anaesth.* 1983; 55:177-85
- [4] From RP, Scamman FL: Ventilatory Frequency influences accuracy of End tidal CO₂ measurements: analysis of seven capnometers. *Anesth Analg* 1988; 67: 884-6.
- [5] Pascucci RC, Aचना JA: Thompson JE, Comparison of a sidestream and mainstream capnometer in infants. *Crit care Med.* 1989; 17(6): 560 – 2.

- [6] Schena J, Thompson J, Crone RK: Mechanical influences on the capnogram. *Crit Care Med* 1984; 12: 672 – 4
- [7] Anderson Cynthia T & Breen Peter H, Carbon dioxide kinetics and capnography during critical care, *Crit care* 2000; 4: 207 – 215.
- [8] Bhavani Shankar : Capnography.com (<http://www.capnography.com>)
- [9] Technology overview: Capnography (Novamatrix Products)
- [10] Frakes Michael et. al. : Measuring end- tidal carbon dioxide - clinical applications and usefulness, *Critical Care Nurse*, 2001; 25 (5)
- [11] Service Manual, Technical Manual and Operators Manual – Drager Narcomed 3
- [12] Owen Markus R, Lewis A Mark : The mechanics of lung tissue under high–frequency ventilation, *society for industrial and applied mathematics, Siam journal on applied mathematics*, 2001, 61 (5), 1731-1761
- [13] Proctor David N, Beck Kenneth C: Delay time adjustments to minimize errors in breath-by-breath measurement of Vo₂ during exercise. *Journal of Applied Physiology*, 1996, 81(6), 2495-2499.
- [14] La Valle TL , Perry AG: Capnography- Assessing end-tidal CO₂ levels, *Dimensions of Critical Care Nursing*. 1995; 14(2): 70–77.
- [15] Shakya K, Deegan C, Hegarty F : Determination of the frequency response of an End tidal CO₂ analyser , *ITB Journal ,Institute of Techonology Blanchardstown , Dublin*, 2003 ,Issue No. 8.
- [16] Garrett Lyons: Some notes on device calibration, *Trinity College, Dublin, Mechanical engg. Dept*,
- [17] Hegarty F ,Lennon B, Private communication
- [18] User’s Guide for monitor setup and Reference , S/5™ Compact Anaesthesia Monitor , Datex Ohmeda