



Technological University Dublin
ARROW@TU Dublin

Conference Papers

Space Research Group

2010-05-01

A Novel Telescopic Boom Deployment System for Use in Upper Atmosphere Research

Mark Wylie

Technological University Dublin, mark.wylie@tudublin.ie

Paul Duffy

Technological University Dublin

Dinesh Vather

Technological University Dublin

Johnalan Keegan

Technological University Dublin, johnalan.keegan@tudublin.ie

Stephen Curran

Technological University Dublin

Follow this and additional works at: <https://arrow.tudublin.ie/srgcon>



Part of the [Aerodynamics and Fluid Mechanics Commons](#), and the [Space Vehicles Commons](#)

Recommended Citation

Wylie, M., Duffy, P., Vather, D., Keegan, J., Curran, S.: A Novel Telescopic Boom Deployment System for Use in Upper Atmosphere Research. *International Manufacturing Conference*, Mayo, Ireland, 2010.

This Conference Paper is brought to you for free and open access by the Space Research Group at ARROW@TU Dublin. It has been accepted for inclusion in Conference Papers by an authorized administrator of ARROW@TU Dublin. For more information, please contact yvonne.desmond@tudublin.ie, arrow.admin@tudublin.ie, brian.widdis@tudublin.ie.



This work is licensed under a [Creative Commons Attribution-NonCommercial-Share Alike 3.0 License](#)



A NOVEL TELESCOPIC BOOM DEPLOYMENT SYSTEM FOR USE IN UPPER ATMOSPHERE RESEARCH

Paul Duffy, Mark Wylie, Stephen Curran, Dinesh Vather and Johnalan Keegan

DIT Space Research Group, Dublin Institute of Technology, Bolton St, Dublin 1, Ireland

ABSTRACT

Typical measurement probe deployment systems on sounding rockets employ hinged booms which extend the probes away from the rocket. This configuration often has a significant mass and may require a considerable amount of the rocket's valuable payload volume. In an effort to reduce both mass and volume, the DIT Space Research Group have designed a light weight carbon fibre telescopic boom system, compatible with measurement probes commonly used in upper atmosphere research. Our design has been selected to be tested on a suborbital space flight onboard the REXUS 9 sounding rocket in March 2011. The purpose of this test is to characterise the boom system in-situ and increase its Technology Readiness Level (TRL). The system is capable of deploying a boom with a mock electromagnetic field (E-field) probe to a length of $1.63\text{m} \pm 0.5\%$. The mock probe will be attached to the distal end of the boom and will house six LEDs, which emit light at a wavelength of 620 nm. A filtered camera measurement system will gather this light allowing the boom deployment length, deflection and amplitudes of any displacement due to vibration to be measured and recorded. An accelerometer mounted in the probe will monitor vibration frequencies. The boom will deploy from the rocket at an altitude of approximately 70Km and will be jettisoned before re-entry. All data obtained during the flight will be stored on a solid state memory device and then recovered for post flight analysis. A downlink to a ground station will provide a live TV feed of boom deployment and jettison. The entire system has a mass budget of less than 4kg and can be contained in a rocket module of 348 mm diameter and 220 mm height.

KEYWORDS: Aerospace, Engineering, Sounding Rocket, Booms

1. INTRODUCTION

This project is part of the REXUS/BEXUS programme. The REXUS/BEXUS programme is realised under a bilateral Agency Agreement between the German Aerospace Centre (DLR) and the Swedish National Space Board (SNSB). The Swedish share of the payload has been made available to students from other European countries through collaboration with the European Space Agency (ESA) EuroLaunch, a cooperation between the Esrange Space Centre of the Swedish Space Corporation (SSC) and the Mobile Rocket Base (MORABA) of DLR, is responsible for the campaign management and operations of the launch vehicles. Experts from ESA, SSC and DLR provide technical support to the student teams throughout the project. Funding for the project is being provided by the Dublin Institute of Technology, Enterprise Ireland and Acra Control Ltd.

1.1 Overview of the REXUS/BEXUS Project

The REXUS/BEXUS project allows students from universities across Europe an opportunity to carry out scientific and technological experiments on sounding rockets and high altitude

balloons. Two rockets and two balloons are launched each year from the Esrange space centre in northern Sweden, carrying a total of up to twenty experiments. The Telescope experiment will fly onboard the REXUS 9 sounding rocket which is due to be launched in March 2011.

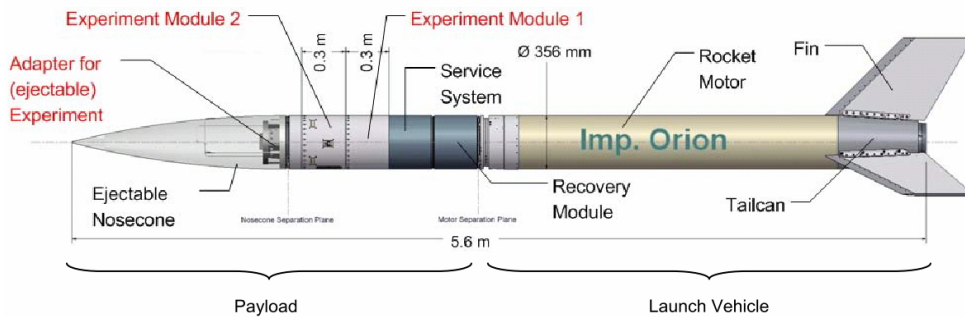

Figure 1: REXUS standard configuration

The REXUS vehicle is an unguided, spin-stabilized, solid-propellant single stage rocket, shown in Figure 1. The total mass of the rocket is around 515 Kg comprising a propellant mass of 290 Kg, motor and vehicle hardware of around 125 Kg and a payload mass of around 100 kg. The rocket has a total length of approximately 5.6 m and a diameter of 356 mm. The standard configuration of the payload comprises the recovery module, the service system, an ejectable nosecone and two or three experiment modules. After lift-off, the motor will burn out at an altitude of about 25 Km. The motor will then separate from the payload, with the payload continuing up to an altitude of approximately 100 Km before descending again. A parachute then deploys from the recovery module before the payload hits the ground. The flight profile can be seen below in Figure 2.

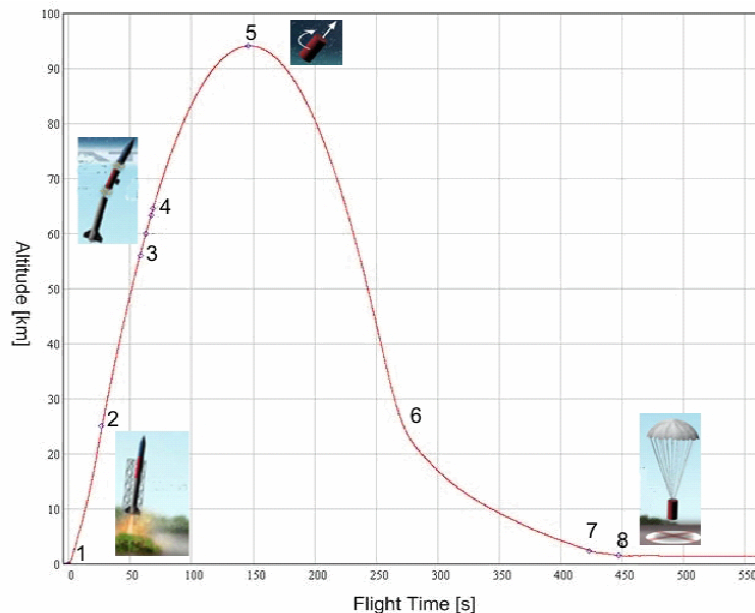

Figure 2: Graph of experiment altitude against flight time showing major flight events.

(1 = lift off, 2 = motor burnout, 3 = nose cone ejection, 4 = motor separation, 5 = apogee, 6 = max. deceleration, 7 = stabilising parachute deployment, 8 = main parachute deployment)

2. TECHNICAL BACKGROUND

Upper atmosphere research is a valuable tool in better understanding the effects of both Earth based pollution and solar weather on our planet. High altitude balloons, sounding rockets and satellites are all employed to conduct measurements at altitudes ranging from tens to thousands of kilometres. High altitude balloons offer a relatively cheap and simple method of conducting this research. Experimental payload design and testing is also relatively quick but the maximum attainable altitude is usually no more than 45km. Sounding rockets provide a method for conducting upper atmospheric research at much greater altitudes, typically between an altitude of 45km and 160km. However, some sounding rockets can reach altitudes of over 1500 km. The minimum altitude for satellite research is about 160km. The advantage of satellite experiments is that they can take measurements in the space environment for much longer periods of time. Satellites can also conduct similar research on other celestial bodies. However, payload design and testing takes much longer and overall costs are much higher than for the other options.

The Earth's magnetic field and atmospheric plasma electron density are typically measured by Electric Field and Langmuir probes. Electric field, or E-Field, probes as their name suggests, are used to measure the magnitude of electric fields in the atmosphere. They can be split into two main classifications: active or passive probes and are usually deployed in pairs. Langmuir probes are used to measure the ionisation energy and electron temperature of plasma. Measurements can be made using one probe however as many as five probes have been used with certain configurations. In order to take their measurements these probes have to be extended out from the balloon/rocket/satellite payload bay. The altitude of the probes must be known at all times for accurate measurements. It is also necessary to extend the measurement probes clear of any wake turbulence or electromagnetic fields created by the main vehicle. As such, a number of different boom systems have been developed to deploy these probes.

Probes extended from the spacecraft by wires are compact; however the vehicle must be spinning in order to take advantage of centrifugal forces which are used to deploy the probes. These probes are prone to oscillation (as they lack rigidity) in turn effecting measurement accuracy. Single rigid booms can support larger probes and are less prone to oscillation, however, they require a large amount of storage space in the main vehicle. Folding booms may require less storage space than single rigid booms but typically weigh more due to the extra joints in their design.

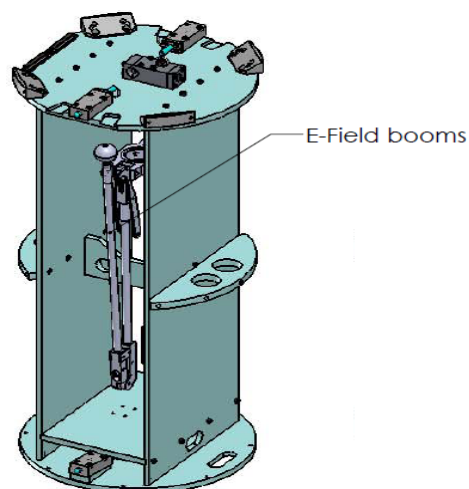

Figure 3: Typical folded E-Field boom configuration [1].

Screw driven telescopic booms can require less storage space than either folding or rigid booms. However they can take time to deploy and cannot take advantage of the centrifugal force generated by spin stabilized craft to deploy. It is clear from the above descriptions that each boom system has both advantages and disadvantages. Figure 4 shows some of the different systems mentioned above. In this case the probes are deployed from a sounding rocket (left) and a satellite (right).

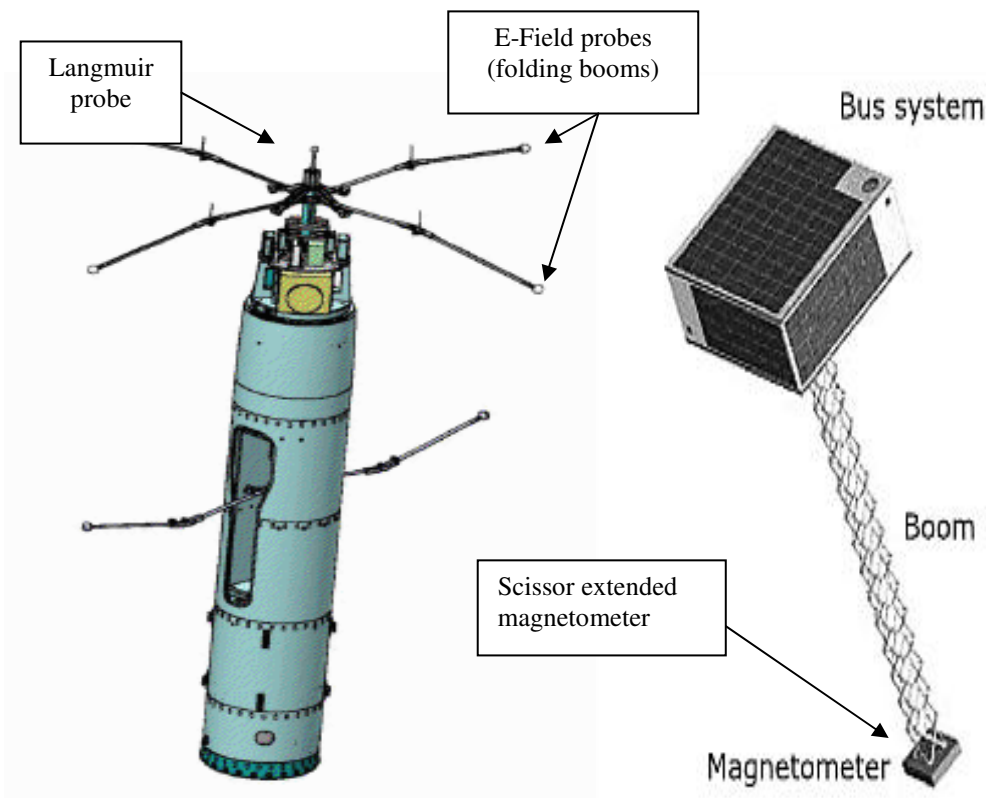

Figure 4: Various sounding rocket and satellite boom systems [2].

A spring loaded telescopic boom system offers storage advantages (similar to screw driven telescopic boom). It can also take advantage of the centrifugal force generated by spin stabilized spacecraft to deploy. The lack of a mechanical drive system in its design also results in both mass and cost savings compared to a screw driven boom. The quick deployment time of a spring loaded boom system means that it is suited to sounding rocket flights where data acquisition times may be limited to a short period of time due to the flight plan in place. A spring loaded telescopic boom would have potential applications in other ways too. This type of boom could be used to deploy antennae, solar panels or other types of measurement probes.

3. EXPERIMENT OVERVIEW

The aim of the Telescobe project is to develop and fly a novel, carbon fibre, telescopic boom system on a sounding rocket. While the carbon fibre boom is being tested extensively on the ground, the aim of the flight is to verify the performance of the boom when it is subjected to the harsh conditions that will be experienced during the flight. These harsh conditions include acceleration forces of up to 21g, high vibration levels, vacuum, low gravity and harsh thermal

conditions. Figure 5 shows an exploded view of the experiment payload. At lift-off, the boom will be stowed in the rocket in a non-extended state. It will be retained in position using pins and cables, open cell foam will be used to prevent the booms smaller sections from shaking during launch. It is intended to deploy the telescopic boom at an altitude of approximately 70 km. A hatch in the skin of the rocket will be opened using a pyrotechnic device and the boom will deploy through the skin to a total length of 1.63m. The boom will then be jettisoned during descent to ensure that it doesn't become entangled in the parachute which deploys from the REXUS rockets recovery module. The rocket will be de-spun prior to the boom being deployed so centrifugal force will be unavailable to assist in boom deployment. As a result, spring based boom deployment and jettison systems have been developed. These different stages are shown in Figures 5 & 6.

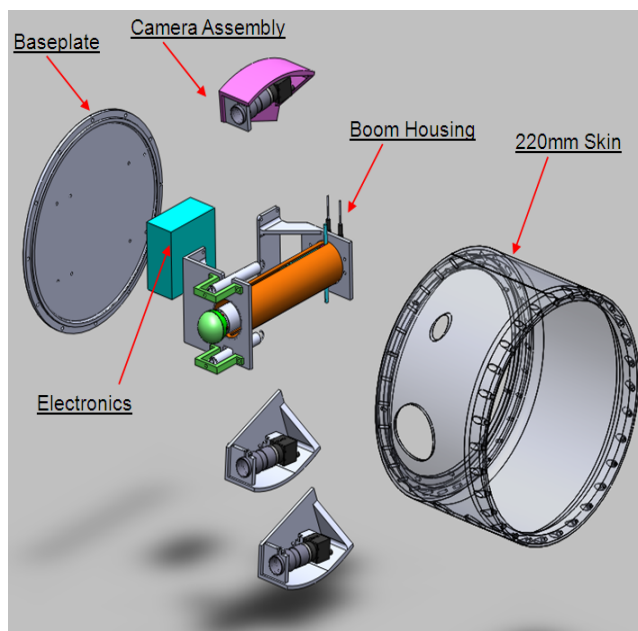

Figure 5: Exploded view of experiment

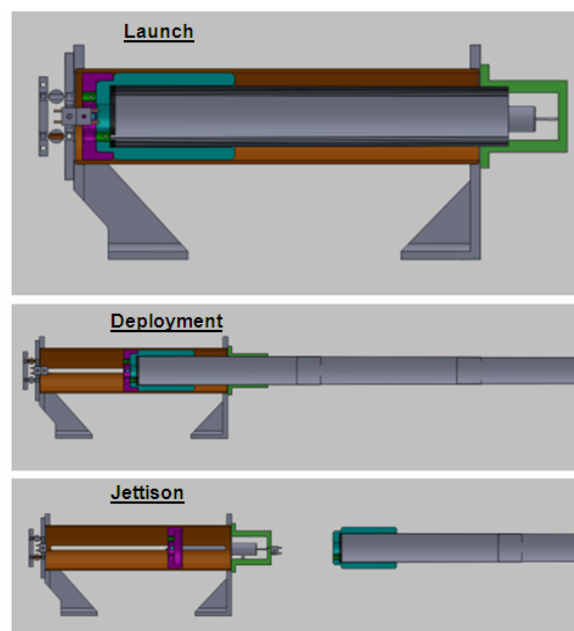

Figure 6: Main boom stages during flight

Data will be gathered to determine the performance of the boom during the flight. Two cameras looking out through windows in the skin of the rocket will be used to determine the exact position of the mock probe fitted to the end of the boom. Six LEDs will be mounted in the mock probe, as shown in Figure 7. A total of six LEDs are required to ensure the camera system has a line of sight to a minimum of two LEDs at all times regardless of any possible boom rotation or excessive deflection during flight. The 620 nm wavelength light emitted by the LEDs will be detected by the camera system and ambient light will be blocked by band pass filters fitted to the camera lenses. This will allow for precision imaging and a reduction in the data which needs to be processed. These cameras will allow the deployment length of the boom to be measured to an accuracy of $\pm 2\text{mm}$ and will also be used to measure the amplitude of vibrational displacement. The principal behind this technique is shown in Figure 8. A digital accelerometer will be placed in the mock probe fitted to the end of the boom. This accelerometer will provide data on the frequency of vibration of the mock probe. A third camera will be used to monitor boom deployment and jettison, providing a live TV feed to a ground station. All of this data will be sent to an onboard PC/104 computer, which will save it to a flash memory card. After the rocket payload lands and is recovered, the memory card will be removed. The data stored on it will then

be analysed to determine if the telescopic boom performed appropriately. MatLab software will be used during this analysis. The PC/104 computer system also controls the experiment during flight, using signals from the REXUS service module to trigger the main experiment events.

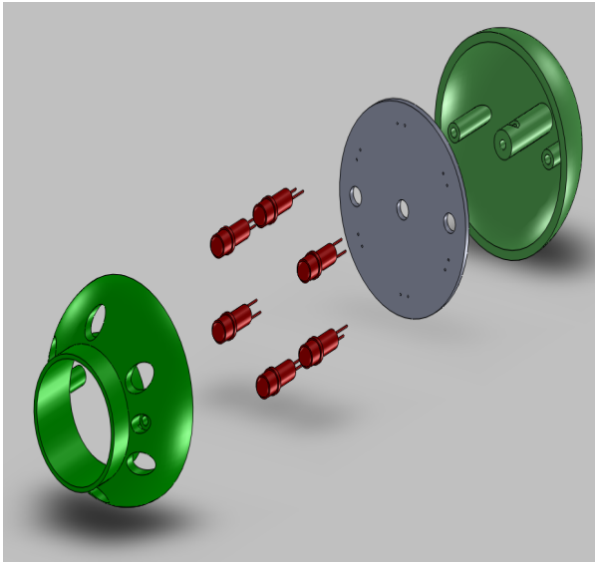

Figure 7: Exploded view of mock probe

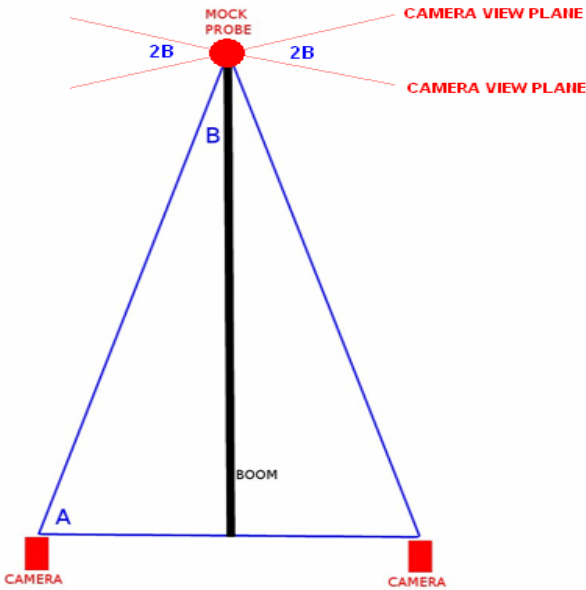

Figure 8: Principle of operation for camera system

4. TELESCOPIC BOOM

The telescopic boom used in the Telescope experiment is made from commercially available carbon fibre fishing poles produced by Shimano Inc. Fishing poles were used because they provide an affordable and readily available source of tapered carbon fibre sections. The fishing pole was cut into a series of 230mm long sections. After some experimentation the use of a rotary tool and grinding disc was found to be the best technique for cutting the boom sections. Figure 9 shows this setup. The pole sections were first mounted in a lathe. The cutting disk of the rotary tool was then positioned using the lathe carriage, allowing an accuracy of 0.001mm. The tool was then switched on and the lathe turned by hand until the cut was complete. The high speed of the cutting disc allowed each section end to be ground to a smooth finish. The quality of the cut is extremely important as carbon fibre is quite brittle and tends to crack if there are imperfections on any of the edges. Eight sections were cut in this way, with the maximum diameter of the largest section being 45mm and the minimum diameter of the smallest section being 20mm. When the sections are placed one inside the other the length of this non-extended boom is 230mm, shown in Figure 10. Then, when the boom is extended, all of the sections lock into each other, with a 30mm overlap between the sections, giving a total extended boom length of 1.63m.

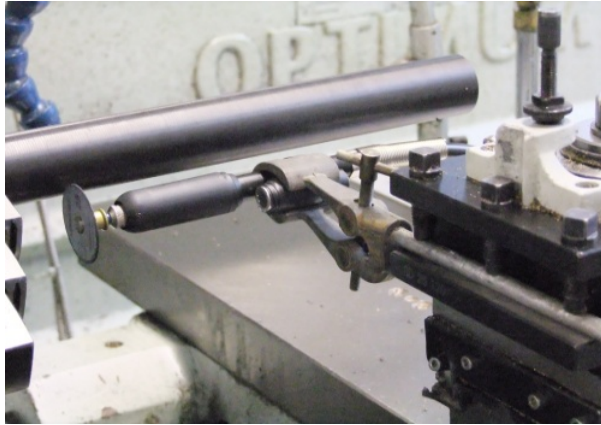

Figure 9: Boom Manufacture

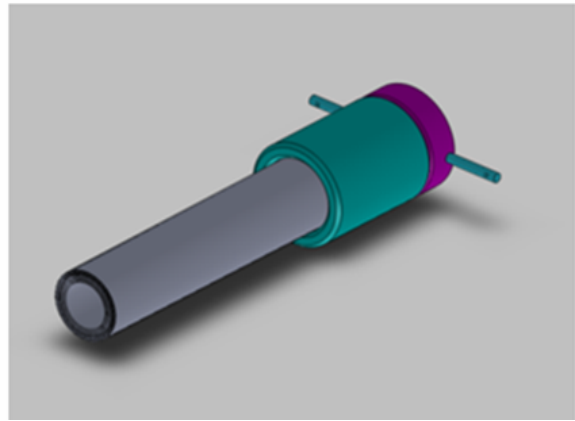

Figure 10: Boom, sleeve and retaining cup

A precise specification of the type of carbon fibre that the fishing poles were made from was unavailable. As such, various tests were carried out to the carbon fibre to prove its suitability for use in the experiment. First, the carbon fibre was submitted to a vacuum test. It was placed in a vacuum chamber and the pressure inside was lowered to below that which is expected during flight. The carbon fibre was then examined under a microscope and found to have no ill effects. A tensile test was also carried out on sections of the carbon fibre which determined that the tensile strength of the carbon is suitable for use on the experiment. Tests were also carried out to determine the strength of the interference fit between the sections and the rigidity of the boom. The results of all these tests were acceptable. The most important performance characteristic of the boom is that it deploys to its designed deployment length during the flight within a tolerance of 0.5%. To test this, a prototype of the boom deployment system that will be used on board the experiment during the flight has been built. For this, a PEEK (Polyether ether ketone) sleeve and an aluminium (2024 T3) base plate were bonded to the largest section of the boom. The PEEK sleeve sits inside an aluminium housing where it can move up and down but is well supported so that there is no lateral movement. The base plate, with boom, is then pulled back against two tension springs ($K = 0.434\text{N/mm}$) on either side of the boom housing and secured with cable to retaining posts. These cables pass through pyrotechnic guillotines (CypressCutters) which will be activated to cut the cable and initiate the boom deployment. The entire boom is accelerated forward approximately 100mm until the boom sleeve is suddenly stopped by a second longer cable. The forces produced by the sudden deceleration provide each boom section with a sufficient amount of energy to deploy the boom its extended state. This system was also designed to be capable of deploying all associated wiring that would be used with actual E-Field probes. This wiring will be stored outside of the boom housing but will pass through the inside of the boom as it deploys. For this purpose, a four core shielded cable is required. For this experiment this wire will provide power to the LED array and accelerometer in the mock probe and well as carry data signals from the accelerometer back to the experiment computer. Extensive testing has been carried out on this deployment system and it has been shown to accurately deploy the boom as long as the deployment spring is sufficiently large to ensure a good interference lock between the carbon fibre sections. A similar mechanism will be used for boom jettison. The cable which retained the boom sleeve after boom deployment will be severed. The remaining stored energy in the two tension springs will be used to jettison the boom through the hatch. It is necessary therefore to detach all physical connections (i.e. the wiring), to do this, a Winchester pull plug will be used which will separate under the forces generated by the jettison sequence. Figure 11 shows an exploded view of the boom deployment and jettison system.

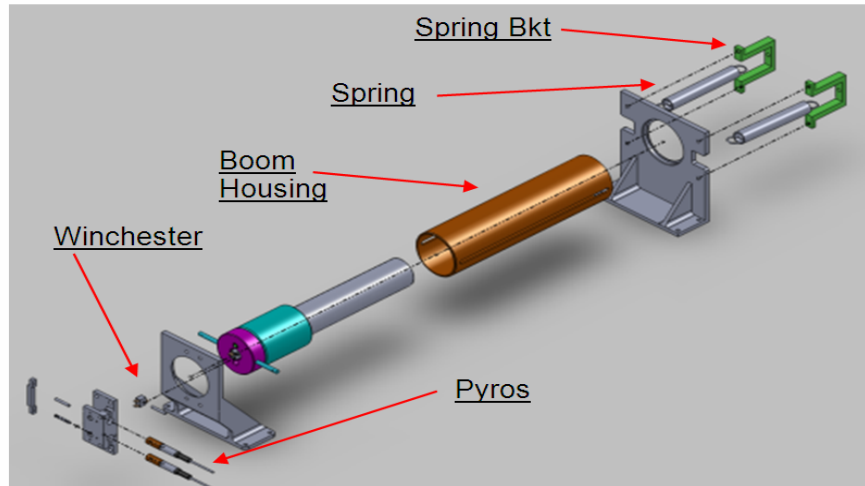

Figure 11: Boom deployment and jettison mechanisms

5. CONCLUSION

The commercially available tapered carbon fibre sections being used to construct the telescopic boom for the Telescope experiment are fit for purpose. The prototype boom has performed well in tests to date. However, all laboratory testing can, at best, only approximate the environmental conditions that will be experienced during the REXUS rocket flight, where the experiment will be subjected to high g-forces, high vibration levels, low gravity, vacuum and extreme thermal conditions. The final test of this approach to sounding rocket boom development will therefore only come from the satisfactory performance of this telescopic boom during the REXUS flight. The Telescope experiment is expected to fly on board the REXUS 9 sounding rocket which will take off from the Esrange space centre in Northern Sweden in March 2011.

6. REFERENCES

- [1]. Helge, L., Hansen, G., "New flight qualified payload by Andoya Rocket Range". ESA-PAC 19th Symposium, Bad Reichenhall, Germany, June 2009
- [2]. <http://directory.eoportal.org/presentations/10000718/10000719.html>.