



Technological University Dublin
ARROW@TU Dublin

Conference Papers

School of Manufacturing and Design
Engineering

2017-09-22

Polar exploration (University Focus) Research into Smart Materials Continues at the University of Dublin with the Development of Methods to Record and Present Data to Demonstrate the Magnetorheological Effect When a Magnetic Field is Applied to a MR Elastomer Sample

Dave Gorman

Technological University Dublin, david.gorman@tudublin.ie

Niall Murphy

Technological University Dublin, niall.murphy@tudublin.ie

Follow this and additional works at: <https://arrow.tudublin.ie/engschmanconn>

 Ray Ekins
Part of the [Manufacturing Commons](#)
Technological University Dublin, ray.ekins@tudublin.ie

Recommended Citation

Gorman, D., Murphy, N. & Eakins, R. (2017). Polar exploration (University Focus) research into smart materials continues at the University of Dublin with the development of methods to record and present data to demonstrate the magnetorheological effect when a magnetic field is applied to a MR elastomer sample. *Tire Technology International Conference*, Hannover, Germany, 20-22 February 2018
doi:10.21427/D7DF59

This Conference Paper is brought to you for free and open access by the School of Manufacturing and Design Engineering at ARROW@TU Dublin. It has been accepted for inclusion in Conference Papers by an authorized administrator of ARROW@TU Dublin. For more information, please contact yvonne.desmond@tudublin.ie, arrow.admin@tudublin.ie, brian.widdis@tudublin.ie.



This work is licensed under a [Creative Commons Attribution-NonCommercial-Share Alike 3.0 License](#)



Describing the Magnetorheological Effect

Research into methods to record and present data to demonstrate the Magnetorheological effect when a magnetic field is applied to a Magnetorheological Elastomer sample.

By Dave Gorman, Niall Murphy and Ray Ekins, Dublin Institute of Technology, Republic of Ireland

A Magnetorheological Elastomer (MRE) is an example of a smart material as it undergoes a change in its physical properties when in the presence of an external magnetic field. This change in properties is known as the Magnetorheological (MR) effect and the manner in which it is achieved and reported, is of critical importance to the future development of MRE-based components. To gain a full understanding of the MR effect, detailed information on the applied magnetic field is required (Gorman *et al.* 2016) as well as the physical strain applied to the MRE sample (Gorman *et al.* 2017).

The External Magnetic Field

One of the main challenges which needs to be overcome for research into MREs to reach its full potential is in comprehensively characterising the magnetic field which is applied to the sample during testing. Research at the Dublin Institute of Technology has shown that simply describing a magnetic field using a single value for the flux density and a single arrow indicating the direction of the field lines is insufficient to allow the test conditions to be replicated by other researchers (Gorman *et al.* 2016). It has also been shown that detailed FEA modelling of the magnetic field does not provide an accurate map of the applied magnetic field. To demonstrate the importance of obtaining detailed physical maps of the magnetic field, 2D and 3D FEA models of the electromagnetic array used during the uniaxial and biaxial testing of MRE samples were produced and compared to the physically measured magnetic field. The 2D FEA model produced using FEMM4.2 software is shown in figure 1. The array consists of 4 electromagnets of 1500 turns each with each electromagnet capable of carrying a current of up to 15 amps. Figure 2 shows the same array modelled in 3D using Ansys Maxwell software.

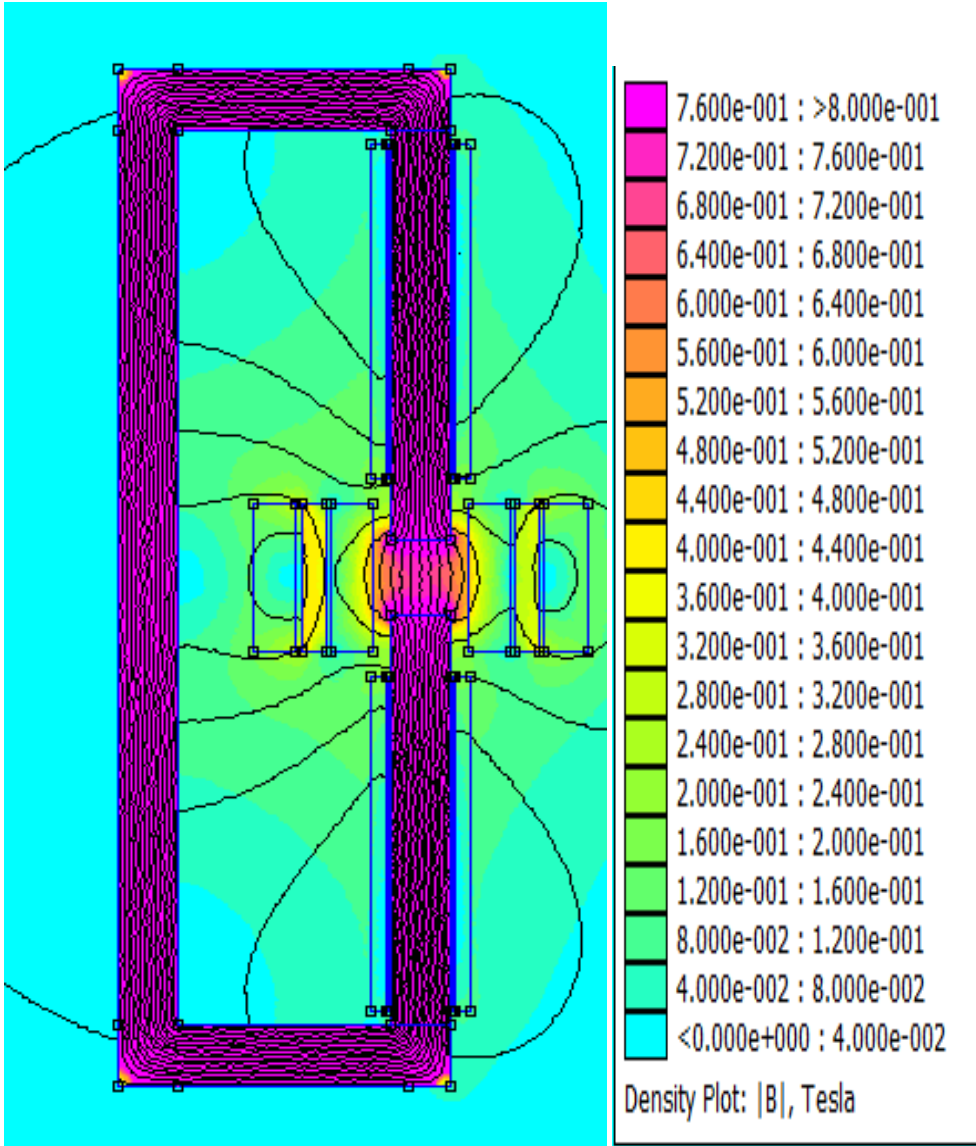

Figure 1 2D FEA model of the test array with 15A per electromagnet, FEMM4.2 software

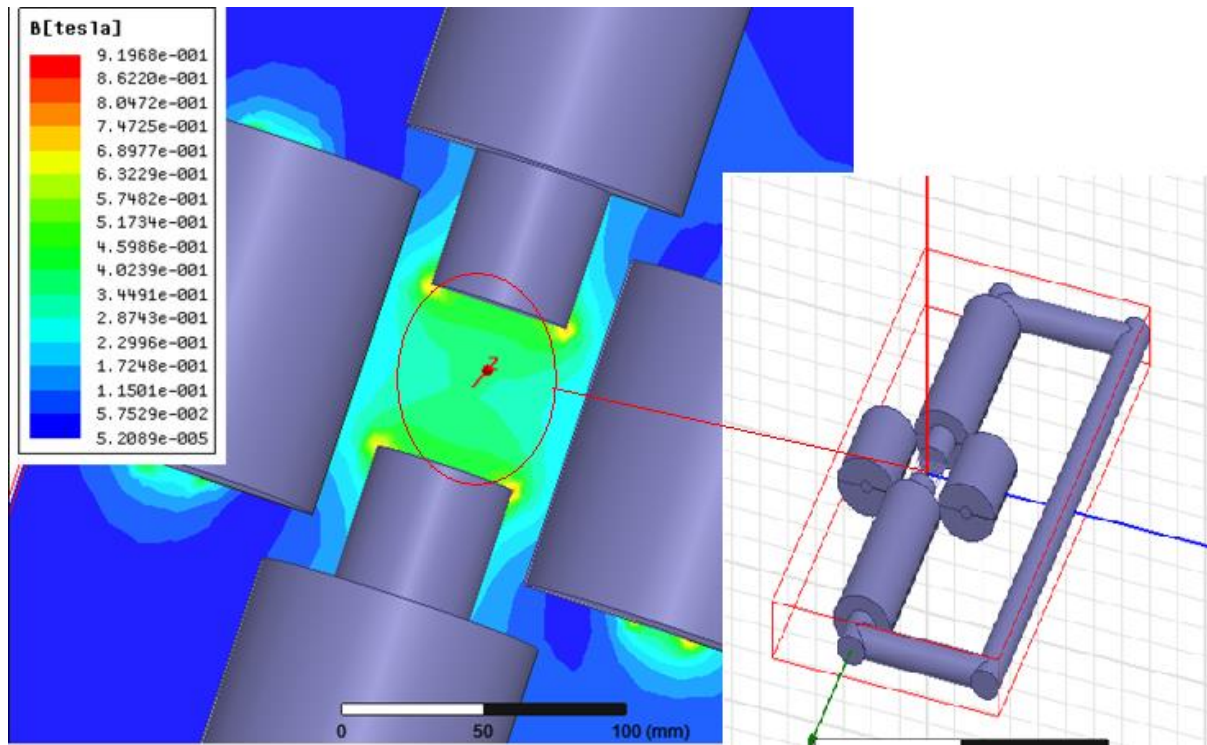

Figure 2 3D FEA model of the test array with 15A per electromagnet, Ansys Maxwell software

Comparing the models in figures 1 and 2 shows that the two FEA models do not calculate the same magnetic flux density, as the 2D model in figure 1 shows a flux density of 650mT at the centre point where as the 3D model in figure 2 predicts a flux density of 350mT for the same point.

A physical map of the actual generated magnetic field produced by the array was created using a 3-axis hall probe and gauss meter with the array placed on a translation stage to facilitate accurate positioning of the hall probe.

The output of the 2D FEA model was subsequently adjusted to take account of the simulated depth of 1cm assumed in the software model. This depth limitation had the effect of reducing the volume through which the magnetic field was dissipated, resulting in the flux density being compressed; this effect may account for the higher predicted flux densities shown in figure 1. Details of the model adjustment method are published by the authors (Gorman *et al.* 2013).

The graph in figure 3 shows the results for the 2D FEA model, the 3D FEA model, the adjusted 2D FEA models, and the physically measured magnetic field. Figure 3 clearly shows that both the 2D and 3D FEA models overestimate the flux density values but the profiles of the fields (reduction in flux density towards the centre of the array, $x = 3\text{cm}$ in figure 3) are in agreement. The adjusted 2D models do not show the same drop towards the centre of the field but provide a very close value for the overall flux densities.

Although the FEA models do not produce the correct flux densities, they both successfully predict the current that will cause the iron cores of the electromagnets to become saturated and provide accurate indications of the direction of the magnetic field lines. Based on this

research into magnetic fields applied to MREs, a new four point standard was proposed for the specification of magnetic fields used for the testing of MREs. (Gorman *et al.* 2016).

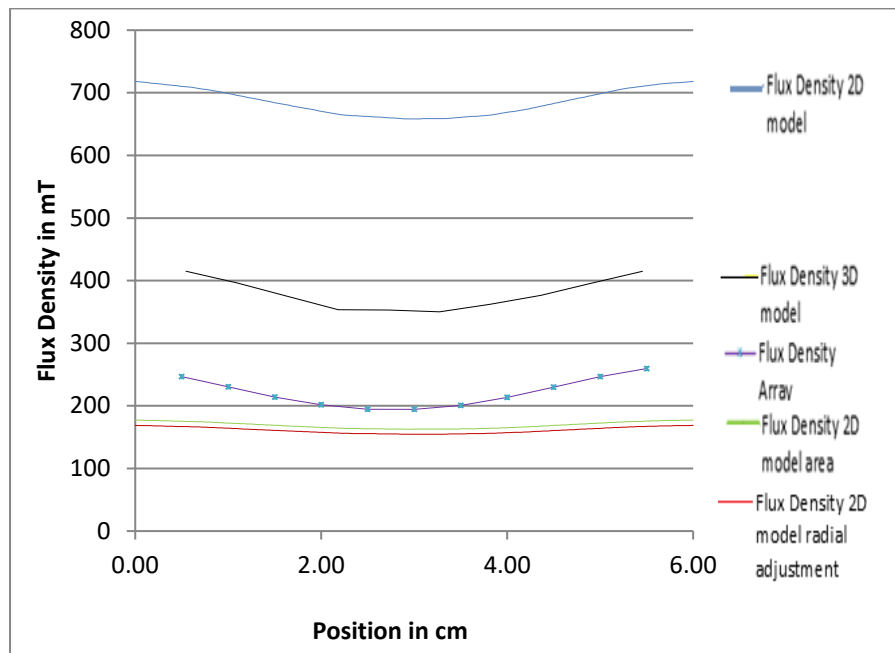

Figure 3 Comparison of modelled magnetic flux densities with the measured magnetic flux density

The MR effect

The second problem which needs to be addressed concerning the accurate replication and reporting of MRE test data, is the provision of an accurate definition of what is meant by the MR effect. Usually, the MR effect is reported as a percentage increase in modulus, however, how that modulus is calculated is often poorly defined (Gorman *et al.* 2016, 2017). Research at DIT used natural rubber isotropic MRE samples as these offer a good potential for MRE-based devices, as they can be manufactured in existing commercial rubber mills without the need for a magnetic field, and process good fatigue and MR properties. The modulus used for all modulus values reported in this article to describe the MR effect is Young's modulus, calculated from the true stress value (engineering stress times stretch ratio (1+strain)) as this takes into account the reduction in the cross sectional area of the sample as strain is increased. The MR effect is then quoted as a percentage increase in the modulus when the field is applied being calculated in the same method ($\Delta E/E_{no\ field} * 100\%$ where ΔE is the change in modulus).

Since modulus is a function of strain, the strain conditions also need to be stated when an MR percentage increase is quoted (Gorman *et al.* 2017). Research at DIT was conducted using both uniaxial and biaxial testing. When equal strain values used for both test methods the modulus recorded and therefore the MR response, will be different as the strain in a biaxial case is greater than a uniaxial case as it is strained in two axis simultaneously. Trends can be compared between uniaxial and biaxial data but the values obtained for modulus and the MR effect will be different.

In order to isolate changes in properties caused by the presence of a magnetic field from other changes in sample composition (different samples for the same batch) or sample conditions (stress softening/strain crystallisation) the magnetic field should be supplied by electromagnets allowing the field to be switched on or off as the sample is undergoing continuous fatigue cycling. For the tests carried out at the DIT, the modulus was calculated for each data point during a test with the field alternating between off and then on for a fixed number of cycles (eg. off-cycles 401-450, on-cycles 451-500). The average modulus for all points without the field present was $E_{no\ field}$ and ΔE is the difference between the average with the presence of a magnetic field and absence of the magnetic field. Figure 4 shows an example of such a test (the field was switched off from cycles 310 to 359 and switched on from cycles 360 to 409, off from cycles 410 to 459 and on from cycles 460 to 509). The blue line shows the average modulus per cycle (50 per block), the red line shows the average over the 50 cycle block and the error bars on the red line are calculated using the standard error formula and represents the mathematical error on the mean due to sample size. Figure 5 shows a biaxial test with 20 cycles per block. Traditional stress strain curves as well as modulus versus strain curves can be obtained from the same data. Figure 6 shows a stress strain curve with the blue line representing the cycles 410 to 459 from figure 4 and the red line cycles 460-509 from figure 4.

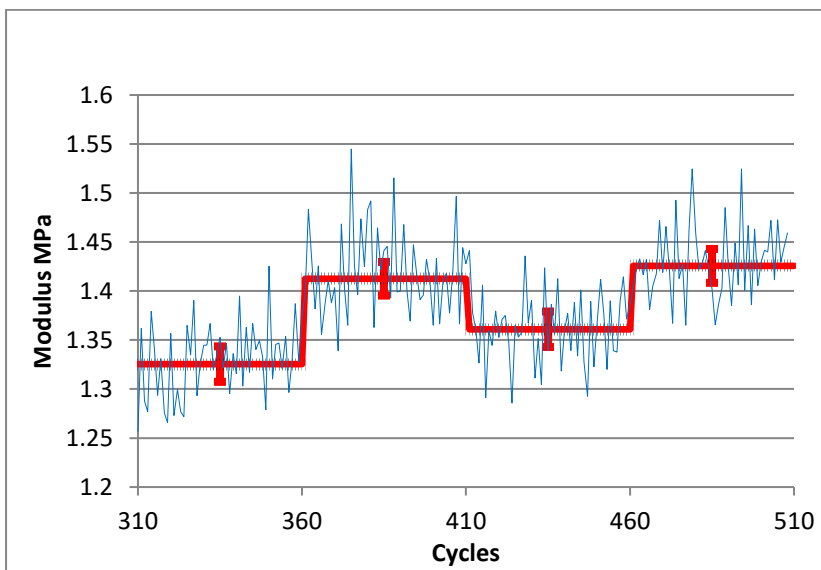

Figure 4 Average modulus and errors uniaxial test 206mT 0.04-0.08 strain MR effect 6.5%

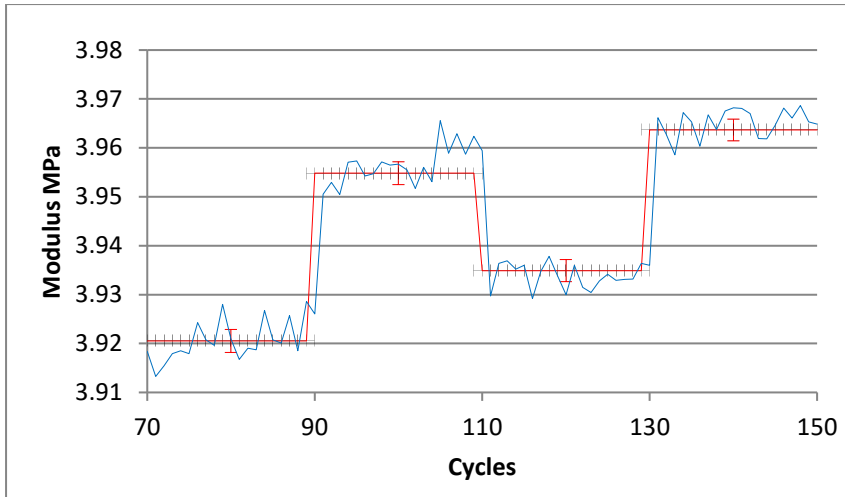

Figure 5 Average modulus and errors uniaxial test 198mT 0.1-0.4 strain MR effect 0.8%

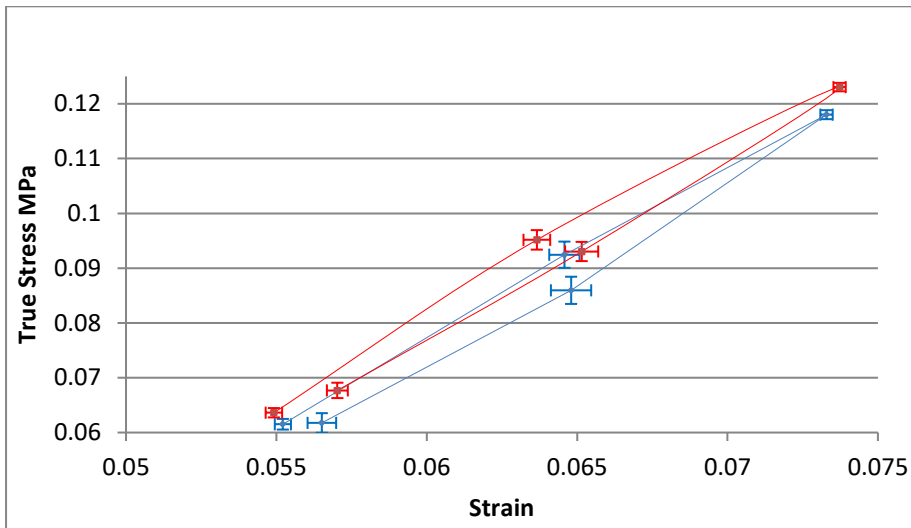

Figure 6 Stress strain curves from figure 5 uniaxial red field (206mT) blue no field

Research into MREs at DIT has shown that the MR effect is dependent on a number of factors. Firstly, the applied magnetic flux density with a higher flux density resulting in a greater MR effect for the same strain conditions (Gorman *et al.* 2016). Secondly when strain conditions were investigated with the same applied flux density, the MR effect was inversely proportional to the strain. The higher the strain, the further the magnetic particles in the sample are displaced from each other and the lower their interaction resulting in a lower MR response. However, the MR response is also influenced by the lower strain limit as the effect increases in the lower strain portions of the cycle when the particles are closer together. In order to determine the high strain response of an MRE, samples should be tested at high strain values with a pre-strain applied (eg. from 0.4-0.5, not 0.0-0.5 strain)

References

- Gorman, D., Jerrams, S., Ekins, R., Murphy, N., 2013. Generating a variable uniform magnetic field suitable for fatigue testing magnetorheological elastomers using the bubble inflation method. *Constitutive models for rubber viii*. CRC Press, pp. 671-675.
- Gorman, D., Murphy, N., Ekins, R., Jerrams, S., 2016. The evaluation and implementation of magnetic fields for large strain uniaxial and biaxial cyclic testing of magnetorheological elastomers. *Polymer Testing* 51, 74-81.
- Gorman, D., Murphy, N., Ekins, R., Jerrams, S., 2017. The evaluation of the effect of strain limits on the physical properties of magnetorheological elastomers subjected to uniaxial and biaxial cyclic testing. *International Journal of Fatigue* 103, 1-4.