



Technological University Dublin
ARROW@TU Dublin

Conference Papers

School of Mechanical and Design Engineering

2001

Energy Reduction by Enhanced Evaporative Cooling of Buildings in Maritime Climates

Ben Costelloe

Technological University Dublin, ben.costelloe@tudublin.ie

Donal Finn

University College Dublin, donal.finn@ucd.ie

Follow this and additional works at: <https://arrow.tudublin.ie/engschmeccon>

 Part of the [Mechanical Engineering Commons](#)

Recommended Citation

Costelloe, B. & Finn, D. (2001). Energy reduction by enhanced evaporative cooling of buildings in maritime climates. *REMIC: Renewable Energy in Maritime and Island Climates/i>, Belfast, 10-11 September*. doi:10.21427/D7SP7W

This Conference Paper is brought to you for free and open access by the School of Mechanical and Design Engineering at ARROW@TU Dublin. It has been accepted for inclusion in Conference Papers by an authorized administrator of ARROW@TU Dublin. For more information, please contact yvonne.desmond@tudublin.ie, arrow.admin@tudublin.ie, brian.widdis@tudublin.ie.



This work is licensed under a [Creative Commons Attribution-NonCommercial-Share Alike 3.0 License](#)



Energy Reduction by Enhanced Evaporative Cooling of Buildings in Maritime Climates

Ben Costelloe, *MSc., C.Eng., MInstE., MCIBSE. Lecturer, Faculty of Engineering, Dublin Institute of Technology, Ireland.*

Donal Finn, *PhD., C.Eng., M.ASHRAE. Lecturer, Department of Mechanical Engineering, University College Dublin, Ireland.*

ABSTRACT

Direct cooling of buildings by water evaporation has traditionally been seen as appropriate, only, in dry and arid climates, which experience high levels of wet bulb temperature depression. The technique has generally not been applied in maritime climates where low levels of wet bulb temperature depression are frequently found. However, recent developments in enhancing heat and mass transfer in cooling towers, together with the success of high temperature sensible cooling systems, such as chilled ceiling panels and beams, have prompted a review of the evaporative cooling technique as an effective and low energy means of cooling modern deep plan buildings, in maritime climates. At present, however, there is little in depth research and analysis of the performance, energy efficiency, and availability of this form of cooling in maritime conditions. To address these issues an experimental research programme has been established with a view to demonstrating the potential and optimising the design of this form of cooling under low approach conditions.

This paper presents the results of recent experimental research into the electrical consumption of a prototype inverter controlled cooling tower when generating cooling water at the chilled water temperatures required for chilled ceiling panels and beams, under varying load and wet bulb temperature approach conditions. Energy consumption efficiencies are presented for a range of specific conditions and typical annual efficiencies are computed. Results are compared with typical energy consumption efficiencies of conventional, vapour compression based, cooling systems. A considerable potential for the reduction of cooling electrical energy consumption, in maritime climates, is shown.

Keywords: FREE COOLING, LOW ENERGY COOLING, EVAPORATIVE COOLING, COOLING TOWERS, CHILLED CEILINGS, CHILLED CEILING PANELS, CHILLED BEAMS

Corresponding author:

Ben Costelloe
DIT Bolton Street
Dublin 1
Ireland.

Phone: 353-1-4023826, Fax: 353-1-4926326, Email: ben.costelloe@dit.ie

1. INTRODUCTION

While it is generally believed, that the generation of cooling water by evaporative means, may result in significant reductions in building energy consumption in comparison with chilled water which has been generated, by means of conventional vapour compression refrigeration systems, there is little published experimental research which would confirm and inform this view (De Saulles 1996). Indeed some aspects of the evaporative cooling technique tend to increase rather than reduce energy consumption (Field 1998).

A crucial feature of the success of evaporative cooling in maritime climates is the achievement of a low temperature difference between the water exiting from the tower and the ambient wet bulb temperature (the primary approach temperature). As shown in Figure 1 this is necessary in order to ensure a significant level of cooling water availability in Summer, when ambient wet bulb temperatures are high. This aspect is complicated by the requirement, in contemporary applications, to separate the tower water circuit from the building cooling circuit by means of a heat exchanger. Hence the crucial design parameter becomes the temperature difference between the water exiting from the heat exchanger and the ambient wet bulb temperature (the secondary approach temperature). Recent research (Costelloe and Finn 2000) on a prototype evaporative cooling rig, has shown that it is quite feasible to achieve a 3 K secondary approach temperature (SAT), and a primary approach temperature of 1.5 K. The prototype rig includes an open, counter-flow, cooling tower, which incorporates a modern packing design and a plate heat exchanger with enhanced heat transfer area. Figure 2 shows the prototype rig in schematic form. However, as there is a direct relationship, in cooling towers, between the approach temperature achieved and the air volume flow rate, the achievement of a low approach condition requires an increase in the electrical power input to the fan motor, when ambient wet bulb temperatures are close to the cooling water temperature sought. For chilled ceilings, which require a cooling water temperature of 14 to 18°C this condition is present in Ireland in Summer when the cooling load is also likely to be at its highest. Hence an optimisation issue arises between the degree of cooling availability and the primary energy consumption of the cooling tower fan. However we should not necessarily assume that the main application for this technology is to generate cooling for chilled ceiling systems in narrow-plan office buildings in which the cooling season is confined largely to the Summer months. The technology can also be used, and probably to greater advantage, in such applications as the modern deep-plan large floor plate layout, so typical of many modern work places. In such applications the cooling load is generated from internal heat gains arising from office equipment and occupants, rather than from solar and external ambient sources and the cooling season can therefore be lengthy and extend into periods of the year with lower ambient wet bulb conditions which favour low energy generation of cooling water by evaporative means.

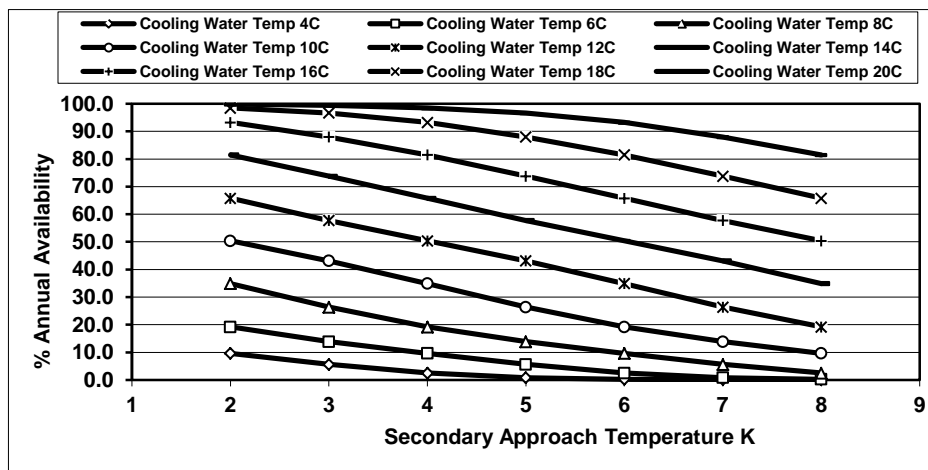

Figure 1. Impact of Secondary Approach Temperature on Percentage Annual Availability of Cooling Water, in Dublin, for a Range of Cooling Water Temperatures (°C)

However the important issue, in this respect, is the annual energy efficiency of the process rather than any specific diurnal efficiency. As the chilled ceiling system generally operates at a constant cooling water flow temperature, the annual energy efficiency can be greatly improved by taking advantage of lower ambient wet bulb temperatures (WBT) in the non-Summer months to increase the SAT by using a modulated reduction in fan speed, such as is provided by an inverter controlled motor. Hence chilled ceiling systems, which can currently operate with a cooling water temperature as high as 18°C, (CIBSE 1998) can be supplied by evaporative cooling systems with a SAT ranging from 11 K in Winter to 3 K in Summer. The lower limit of the process is dictated by the minimum fan motor speed compatible with heat dissipation from the motor windings. Furthermore as the evaporative cooling technique rejects only the cooling load, without the addition of the heat of compression (as would be the case with refrigeration based cooling systems) the process is, also in this respect, inherently more energy efficient than the vapour compression cycle.

2. EXPERIMENTAL RESEARCH

An automated experimental research facility has been designed and constructed at the Dublin Institute of Technology. The facility includes a prototype cooling tower and laboratory test rig with full data logging of all key variables. The electrical energy consumption of all power consuming equipment is individually measured and recorded. The total electrical power consumption of the rig is also measured. Modulated speed control of the cooling tower fan is achieved by inverter control of the fan motor. The cooling load is provided by an in line electric immersion heater with modulated thyristor control. Test results are analysed using computer software and meteorological test reference year (TRY) data. The design and performance of the rig is described in detail elsewhere (Costelloe and Finn 2000).

For this paper a series of ten test runs were completed for the purpose of analysing the energy consumption efficiency of the process. Five tests were run at a nominal cooling load of 20 kW and with a fan power consumption of 100%, 82%, 64%, 34%, and 18% of the maximum value. A further five tests were repeated at the same power conditions but with a nominal cooling load of 14 kW. Ambient wet bulb temperatures ranged from 8 to 13°C.

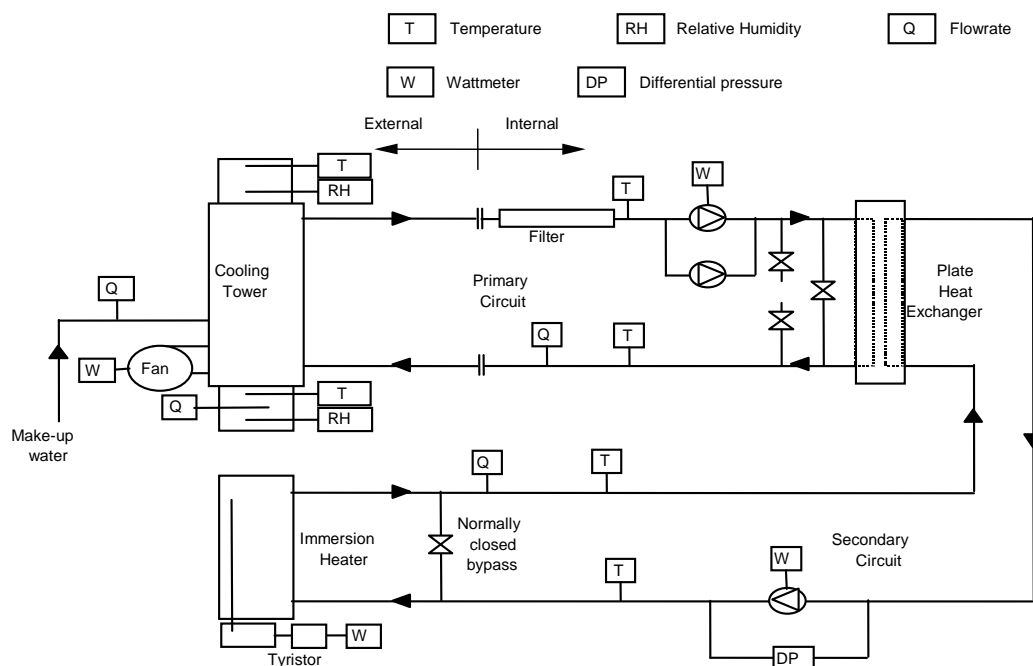

Figure 2. Schematic of Prototype Evaporative Cooling Rig

3. RESULTS

Table 1 shows a summary of results for all ten tests. Figure 3 and 4 show two test results in detail, both at a cooling load of 20 kW. Figure 3 shows the results for 100% fan power which resulted in an average SAT of 2.6 K over the course of the test, while Figure 4 shows the results for 18% fan power which resulted in an average SAT of 6.9 K. As the approach temperature is low and the air volume flow rate is high in the prototype cooling tower, in comparison with conventional condenser cooling parameters, the heat rejection process tends to be dominated by evaporation with little sensible heat transfer. In fact the process, as regards the tower air flow, is almost isothermal.

Figure 3 and 4 show how the secondary flow temperature tracks the ambient wet bulb temperature, rather than the more widely fluctuating ambient dry bulb temperature. This close tracking is significantly more evident with a 100% primary power input (Figure 3), than with 18% input (Figure 4). This is due to the widening enthalpy differences and the increasing role of sensible heat transfer to the air, which results from decreasing the air volume flow rate through the tower.

Figure 5 shows the dependence of the SAT on the cooling tower fan primary power for the series of ten tests. The temperatures and power inputs shown are the average values over the course of the test. The trend shown in both cases shows an accurate power law relationship with a very high R^2 - Pearson coefficient - in both cases. Figure 6 expresses the relationship between the fan primary power input and the primary power rate (PPR). The primary power rate, which is defined as the primary power (kW) required to produce one kW of cooling (Lamp, Ziegler 1998), is the inverse of the coefficient of performance (COP), the normal measure of energy efficiency used for refrigeration systems. For a standard vapour compression system the PPR would normally range from 0.36 to 0.15 or 2.7 to 6.7 in COP terms, depending on size, compressor type, percentage load, and mode of condenser heat rejection (Davis et al. 1999).

Table 1. Summary of Results of Energy Efficiency Tests on Prototype Cooling Tower.

Test No.	Cooling Tower Fan Motor Inverter Set Point %	Average Cooling Effect kW	Average Primary Power kW	Average Secondary Approach Temp K	Primary Power Rate (PPR) kW/kW	Equivalent Coefficient of Performance (COP) kW/kW
1	100	20.5	2.2	2.6	0.107	9.3
2	87	20.1	1.8	3	0.090	11.2
3	75	20.2	1.4	3.6	0.069	14.4
4	50	20.2	0.75	4.4	0.037	26.9
5	25	20.4	0.4	6.9	0.020	51.0
6	100	14.2	2.2	1.6	0.155	6.5
7	87	14	1.8	2	0.129	7.8
8	75	14	1.4	2.2	0.100	10.0
9	50	14	0.75	3	0.054	18.7
10	25	13.5	0.4	4.9	0.030	33.8

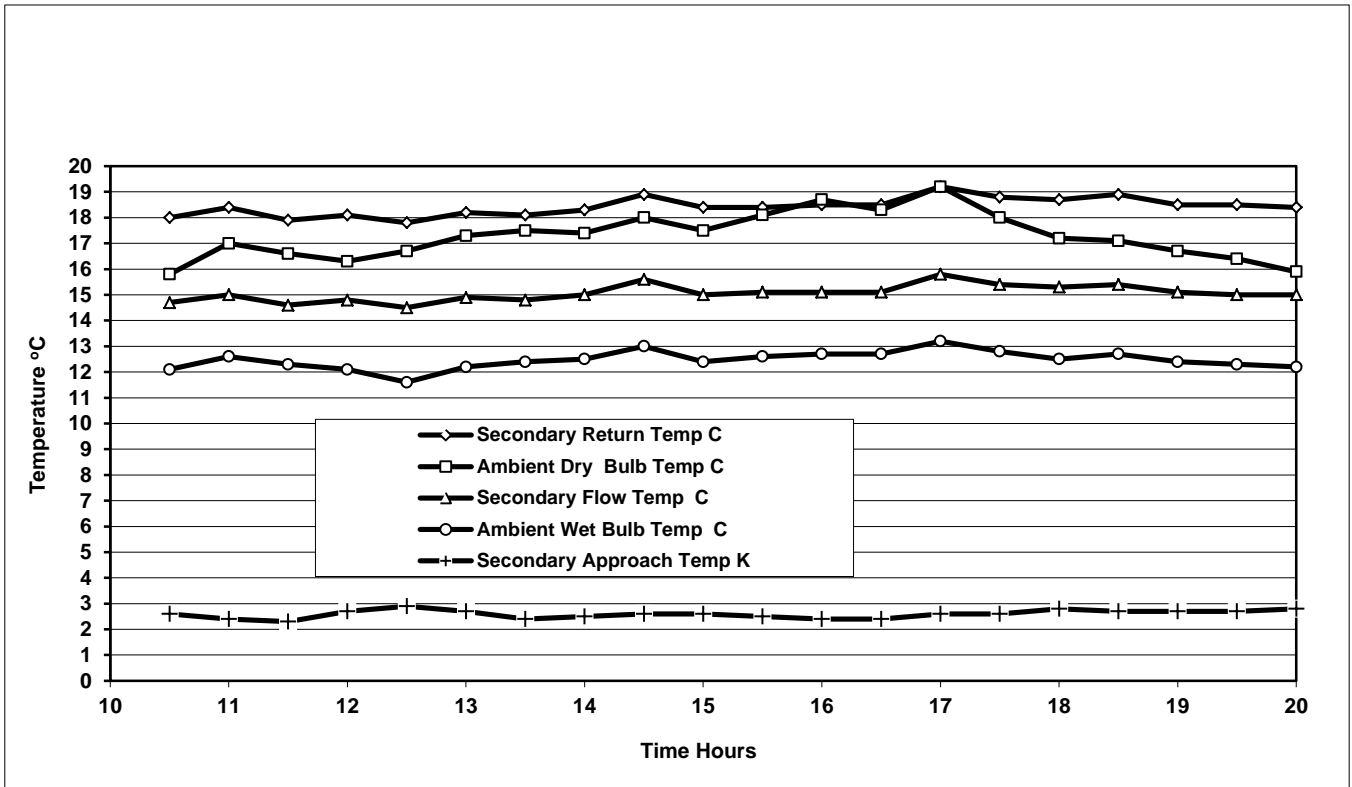

Figure 3. Measured Diurnal Variation in Conditions for 6th September 2000 at Constant 20kW Load and 100% Primary Power Input (results of test No.1)

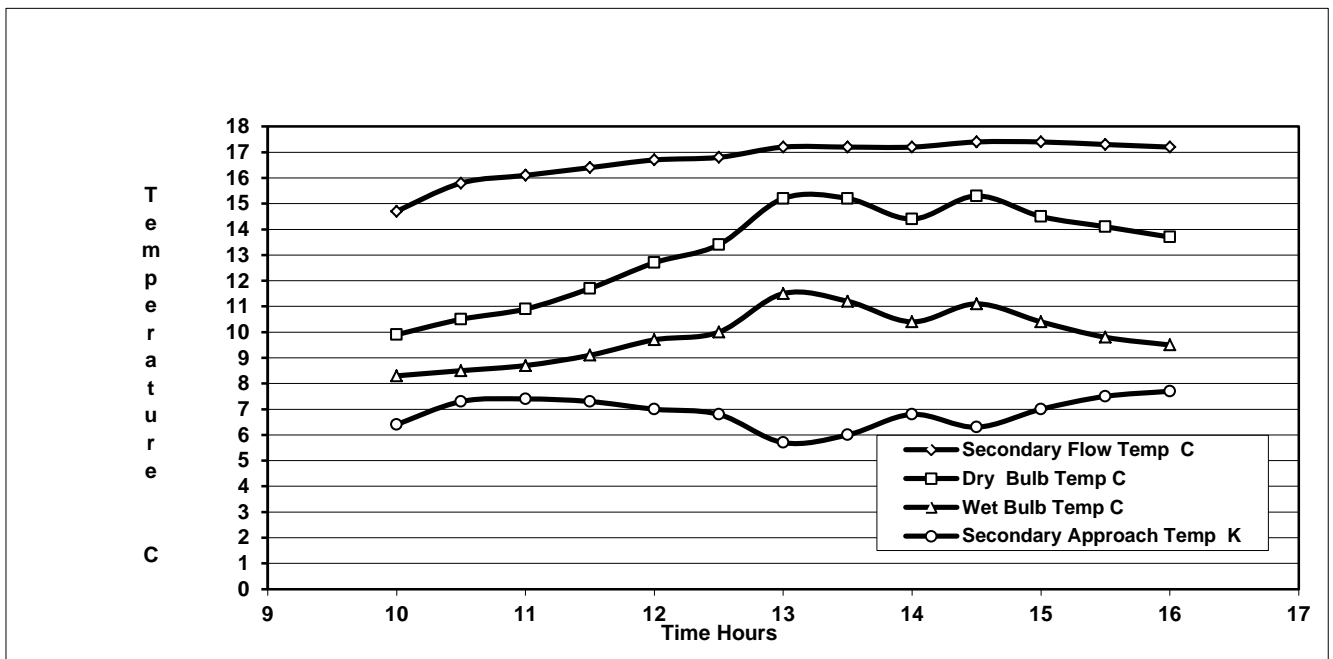

Figure 4. Measured Diurnal Variation in Conditions for 20th October 2000 at Constant 20kW Load and 18% Primary Power Input (results of test No.5).

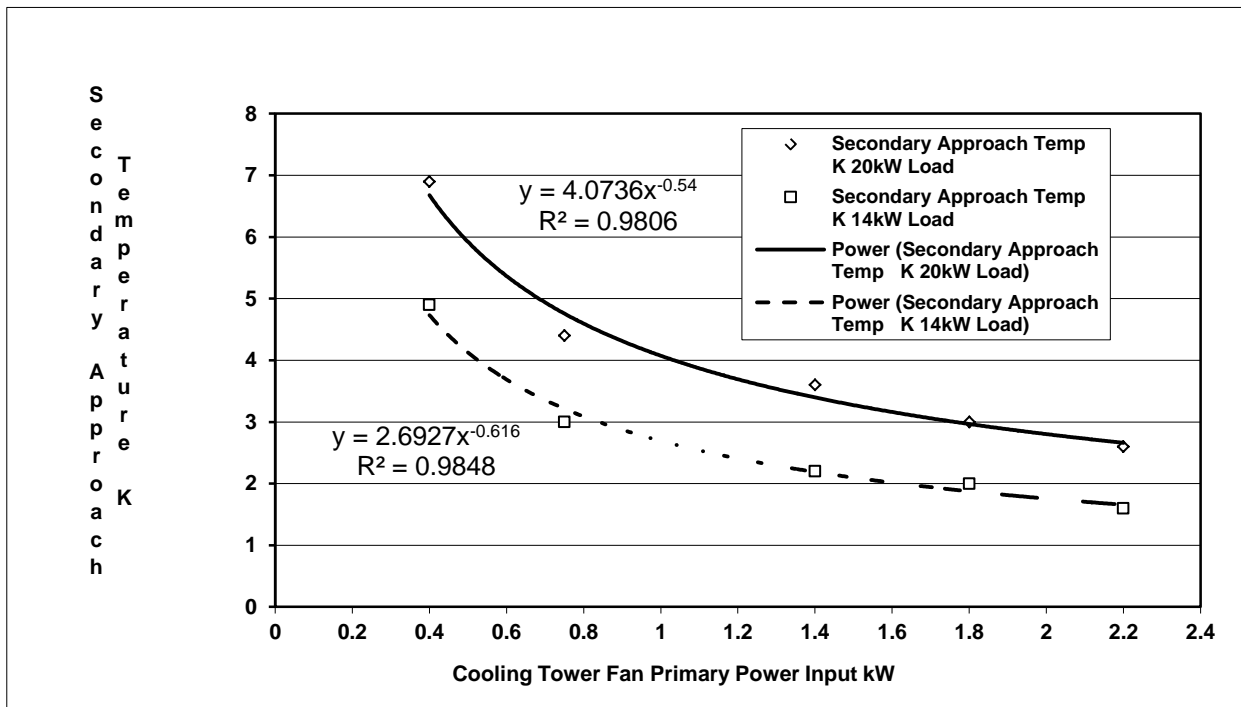

Figure 5. Dependence of the Secondary Approach Temperature of the Cooling Tower on Fan Primary Power Input at a Full Load of 20 kW and at a Partial Load of 14 kW.

4. ANALYSIS AND DISCUSSION OF RESULTS

Figure 5 indicates that the reduction in fan primary power in a tower designed to deliver a low secondary approach condition, is not linear and initially results in only small increases in SAT. For the 20 kW load a fan power reduction of 50% will increase the SAT by only 1 K. However the next 25% reduction will raise the SAT by a further 2 K, showing a rapid increase in SAT at low levels of fan primary power. Figure 6 shows that very low levels of PPR can be achieved with this technique. For the 20 kW load the design load PPR at 0.11 is well below the very best values of 0.15 reported for large, water cooled, centrifugal machines, operating at full load and producing chilled water at conventional temperatures of 5 to 8°C. Furthermore, while some modern vapour compression machines (particularly water cooled screw and centrifugal) display a significant improvement in efficiency, at part load, the part load efficiency of the evaporative cooling process is significantly better than the very best vapour compression processes, when the raised SAT technique is employed. As shown in Figure 6, a tower designed for a 20 kW heat rejection load but which is operating at a part load of 14 kW, with a SAT of 3 K will have a PPR of 0.054. This is equivalent to a coefficient of performance of 19 and is approximately three times more energy efficient than the best vapour compression alternatives at part load.

When modulated fan speed control is employed even lower PPRs can be achieved when advantage is taken of the falling ambient wet bulb temperature to raise the SAT, to obtain a fixed cooling water supply temperature. By using a meteorological test reference year (TRY) the typical availability of wet bulb temperature can be determined for each location. Hence it is possible to determine the required series of SATs, and their associated availability through out the year, for any given cooling water temperature. Knowing the relationship between the primary power and the SAT from the experimental work the primary energy, required through out the year, can be established. Table 2 shows such an analysis for an 15°C supply water temperature at a constant 20 kW cooling load for a full year. The analysis shows that, in that period of a full year, for which it is possible to generate 15°C cooling water by evaporative means in Dublin (7425 hours), a primary

energy consumption of 4,474 kW hours was required to reject a total of 148,500 kW hours. This gives an annual primary energy rate of 0.030 for Dublin, which is equivalent to an annual average COP of 33.

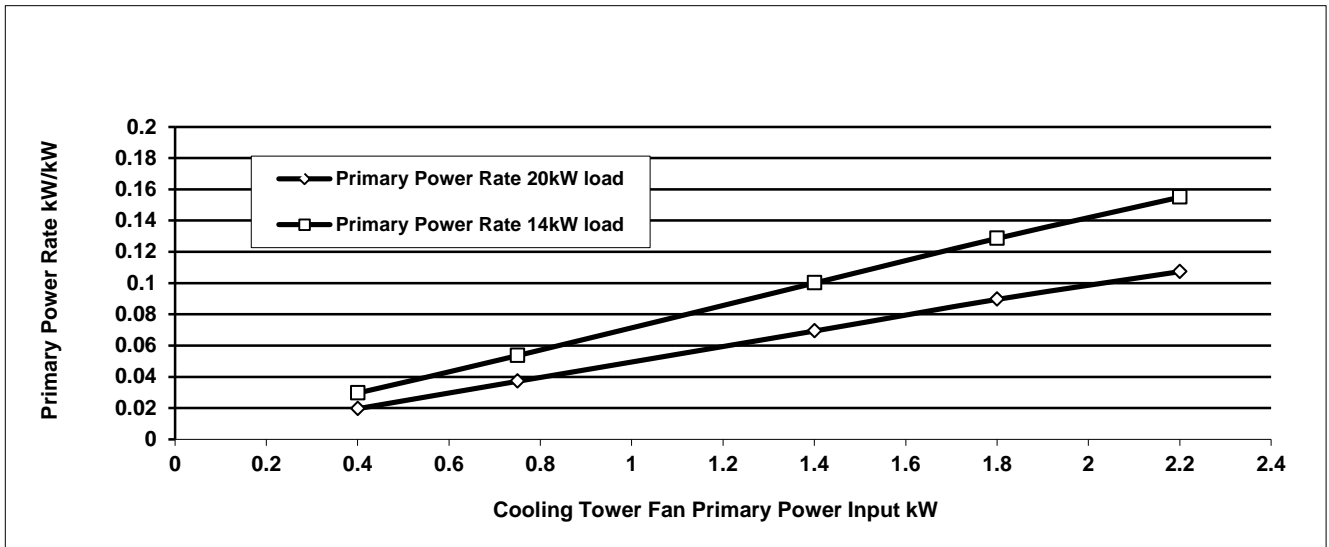

Figure 6. Relationship Between Primary Power Rate and Fan Primary Power Input for the Prototype Cooling Tower for two Heat Rejection Loads of 20 and 14 kW.

Table 2. Computation of Annual Energy Efficiency with a Variable Secondary Approach Temperature for a Constant 15°C Cooling Water Generation and 20kW Load.

Ambient WBT Dublin	Number of annual hours less than or equal to the WBT TRY basis	Number of annual hours at the WBT TRY basis	% annual hours less than or equal to the WBT TRY basis	Secondary approach temperature K required for 15°C cooling water	Primary power required at this secondary approach temperature kW	Primary energy required for this number of hours kWhours	Cooling energy load in this number of cooling hours kWhours	Primary energy rate in this number of cooling hours
7 or less	3778	3778	43.1	8	0.32	1209	75560	0.016
7.5	4103	325	46.8	7.5	0.36	117	6500	0.018
8	4414	311	50.4	7	0.39	121	6220	0.020
8.5	4710	296	53.8	6.5	0.44	130	5920	0.022
9	5058	348	57.7	6	0.48	167	6960	0.024
9.5	5446	388	62.2	5.5	0.54	210	7760	0.027
10	5760	314	65.8	5	0.62	195	6280	0.031
10.5	6115	355	69.8	4.5	0.72	256	7100	0.036
11	6461	346	73.8	4	0.92	318	6920	0.046
11.5	6816	355	77.8	3.5	1.48	525	7100	0.074
12	7137	321	81.5	3	1.8	578	6420	0.090
12.5	7425	288	84.8	2.5	2.25	648	5760	0.113
					Total	4474	148500	0.030

5. CONCLUSIONS

The results of experimental research into the energy efficiency of cooling water generation by evaporative means, under low approach conditions, in a prototype cooling tower have been presented and discussed. The results indicate that the technique can achieve significant reductions in energy consumption at full and part load by comparison with vapour compression refrigeration systems. The following specific conclusions can be drawn:

1. At a full load of 20 kW and with a secondary approach temperature of 2.6K a PPR of 0.11 was achieved. This value is well below the very best values of 0.15 which can be achieved with large vapour compression water cooled centrifugal machines. This is equivalent to a COP of 9.
2. At a part load of 14 kW and with a secondary approach temperature of 3 K, a PPR of 0.054 was achieved. This is equivalent to a COP of 19 and is at least 100% more energy efficient than the best vapour compression alternatives, at part load.
3. When advantage is taken of a falling ambient wet bulb temperature, while generating a constant temperature cooling water, through out the year, the results indicate that major reductions can be achieved in the annual energy consumption. For a constant 15°C cooling water generation, at a constant load of 20 kW, the annualised (over 7425 hours) primary power rate is 0.030, which is equivalent to COP of 33.
4. While substantial reductions in cooling tower fan energy have been shown to be feasible the issue of primary circuit pump energy also needs to be investigated. This issue arises as the cooling water temperature difference (the range temperature) on the primary side is low (typically 2K or less, when a low approach condition is sought) the pump power per unit of heat rejected is higher than with condenser water pumps in vapour compression systems, where a cooling water temperature difference of 5 K is common. However, as advantage can be taken here also of low ambient wet bulb temperatures, the range temperature can be expanded, during off-peak periods, by reducing the primary circuit mass flow rate. This can be achieved either by using a variable speed primary pump or by changing over to a smaller pump, as in the experimental test rig (see Figure 2)

6. ACKNOWLEDGEMENTS

This research programme has been supported by a research grant from the CIBSE research fund, by an applied research grant from Enterprise Ireland, and by the DIT research seed fund. Equipment and services have also been donated by many private companies. The support of the Buildings Office, DIT and of the laboratory staff of the Department of Engineering Technology is also acknowledged.

REFERENCES

- CIBSE, 1998.** *Chilled ceilings and beams, research report RR5.* CIBSE, London.
- Costelloe, B. Finn, D. 2000.** The design and performance of an evaporative cooling test rig for a maritime climate. *Proceedings of joint CIBSE/ASHRAE conference, Dublin, September 2000*, pp830-845.
- Davis, Langdon, Everest. 1999.** Chillers cost model. *Building Services Journal*. No.12 (Dec), pp13-14
- De Saulles, T. 1996.** *Free cooling systems.* p37. BSRIA, Bracknell, UK
- Field, J. 1998.** Building analysis - 1 City Square Leeds. *Building Services Journal*, No.12 (Dec), pp14-18,
- Lamp, P. Ziegler, F. 1998.** European research on solar-assisted air conditioning. *International Journal of Refrigeration*. Vol 21, No.2, pp89-99.