



Technological University Dublin  
ARROW@TU Dublin

---

Teaching Fellowships

Teaching Fellowships

---

2011

## DIT Teaching Fellowship Reports 2010-2011

Jen Harvey  
[Jen.harvey@tudublin.ie](mailto:Jen.harvey@tudublin.ie)

Follow this and additional works at: <https://arrow.tudublin.ie/fellow>

 Part of the Educational Assessment, Evaluation, and Research Commons

---

### Recommended Citation

Harvey, Jen, "DIT Teaching Fellowship Reports 2010-2011" (2011). *Teaching Fellowships*. 18.  
<https://arrow.tudublin.ie/fellow/18>

This Article is brought to you for free and open access by the Teaching Fellowships at ARROW@TU Dublin. It has been accepted for inclusion in Teaching Fellowships by an authorized administrator of ARROW@TU Dublin. For more information, please contact [yvonne.desmond@tudublin.ie](mailto:yvonne.desmond@tudublin.ie), [arrow.admin@tudublin.ie](mailto:arrow.admin@tudublin.ie), [brian.widdis@tudublin.ie](mailto:brian.widdis@tudublin.ie).



This work is licensed under a [Creative Commons Attribution-Noncommercial-Share Alike 3.0 License](https://creativecommons.org/licenses/by-nc-sa/3.0/)



# Contents

## Foreword

## Summary Overview of Projects

## Teaching Fellowship Reports

### College of Applied Arts and Tourism

Using Formative Feedback to Support a Blended Learning Programme  
*Noel Fitzpatrick, Bernadette Burns, Brian Fay* ..... 6

The Correlation between Attendance and Achievement  
*Adrian Davis* ..... 10

### College of Engineering and the Built Environment

Towards an Improved Teaching of Structural Behaviour  
*Colin Caprani* ..... 18

BASICS: Building a System to Ingrain Core Competencies within Students  
*David Dorrán* ..... 25

GeoLearn – Multi-Media Resources  
*Audrey Martin* ..... 30

### College of Business

TechKnow-Share “A Social Learning Framework for Group Projects”  
*Mary Lawlor* ..... 37

### College of Sciences and Health

Improving the Undergraduate Laboratory Learning Experience  
*Julie Dunne and Barry Ryan* ..... 46

Pre-lecture Resources to Reduce In-lecture Cognitive Load  
*Michael Seery* ..... 53

## Teaching Fellowship 2009–2010 Dissemination Outputs

## Appendices

Teaching Fellowships were generously funded through the HEA SIF 2 – DRHEA project



## Foreword

This publication provides a collation of reports of research conducted as part of the 2010–2011 DIT Teaching Fellowship scheme. The DIT Annual Teaching Fellowships were established in 2009 as part of cycle II of the HEA’s Strategic Innovation Funded Enhancement of Learning (EoL) strand of the Dublin Region Higher Education Alliance (DRHEA). This partnership Alliance of eight universities and Institutes of Technology across the wider Dublin region was awarded funding for a range of collaborative activities, with the aim of sharing expertise and creating economies of scale in their efforts to address strategic needs in Teaching and Learning, Graduate Education, Internationalisation and Widening Participation.

The aim of the DIT Teaching Fellowships is to support key college based educational research projects linked to the wider Institute Enhancement of Learning strategy themes. The title of “Teaching Fellow” is awarded to an individual or a team, nominated by the college and who would undertake a research project to support the enhancement of learning and/or curriculum development at a programme, school or college level over a one academic year period. It is intended that evidence gathered from the studies will be utilised to inform relevant policy, practice or similar institutional research activities into the future.

Applications are invited for Fellowship projects that link to the DIT strategic themes related to Diversity, Modularisation and eLearning. (See Appendix A for the 2010/11 Teaching Fellowship Strategy Grid.) In September 2010, nine DIT Teaching Fellowships were launched, two from each of three DIT Colleges and three awarded and match funded by the fourth. Each Fellow was allocated two members of the Learning Teaching and Technology Centre (LTTC) staff to help support their project work. A programme of four Fellowship workshops and project update sessions were scheduled throughout the year. A one-day writers’ retreat was coordinated to encourage the Teaching Fellows to write their work up for a peer reviewed journal paper. A Fellowship website was established: <http://www.dit.ie/lttc/projects/institutionalprojects/>. Each project was asked to maintain regular updates on its work (through a website blog, update presentations and the final reports).

During this academic year, a number of Fellows participated in a session coordinated as part of the National Qualifications Authority of Ireland (NQA) external review of the effectiveness of the quality assurance procedures of the DIT. They were also asked to provide a set of recommendations on the basis of their research data at a DIT Management Forum in May 2011. An evaluative review of the Fellowship process was conducted at the end of the Academic year (see Appendix B). As a result of this feedback a number of changes were made during the third year of the Initiative.

The establishment of DIT Teaching Fellowships continues to be fully embraced by the Institute. This has for the most part been due to the high quality of the work undertaken by the award recipients over the two years since the Awards were established. Similarly to last year, this is clearly evidenced through the reports included in this publication and the number of papers, conference presentations and journal articles arising from this work. As a result, EoL funding was again allocated by the DIT to support eight Teaching Fellowships during 2011/12. Currently, work is underway to sustain this Initiative into the future once external funding ceases.

**Dr Jen Harvey, Head of the DIT Learning, Teaching and Technology Centre**

## Summary Overview of Projects

### College of Applied Arts and Tourism

**Noel Fitzpatrick, Bernadette Burns, Brian Fay: School of Art Design and Printing**



Using the existing BA Visual Art Programme (Sherkin Island), we developed, used and evaluated innovative student feedback mechanisms. The introduction of more formative feedback mechanisms and the introduction of “oral” assessment and feedback aimed to lead to improvements in the effectiveness of both practice based and written feedback that would be of benefit DIT and the wider educational sector.



Research into formative assessment techniques has pointed to feedback as an essential mechanism in the learning process (Gibbs, 2002). We wanted to specifically examine our teaching practices in both practical and theoretical subjects delivered both virtually and contact to identify how student feedback can be more effectively employed.

### Adrian Davis: School of Hospitality Management and Tourism



The overall aim of the research project was to examine the correlation between class attendance and academic achievement within a cohort of first year undergraduate students. The specific objectives of the project were to:

- ascertain whether a definitive relationship exists between attendance & attainment;
- determine the factors which contribute to unsatisfactory attendance by students who do not attend class regularly;

- suggest a strategy for enhancing student attendance;
- identify further research opportunities in the broader context of student engagement.

The benefits of the proposed research project findings will be to inform, both at student, institutional and national level, the relationship between class attendance and academic achievement during the first year of participation in higher education. Furthermore, the study will endeavour to identify factors which contribute to the lack of engagement by some students.

### College of Business

**Mary Lawlor: School of Marketing**



Evaluating a Webinar approach to delivering a module in Marketing Planning, this project set out to develop a module for Marketing planning which will be a blend of virtual and face-to face interaction. It is the intention that this module would be suitable for delivery to part-time or full time students. The main objective of this project is to investigate how interactivity can be designed into a module to enhance learning and improve engagement

among the learners. The learning outcomes of the module are the key consideration in the design of several academic tasks which will require learners to apply what they have learned. The main interest is how these tasks can increase interaction between: Instructor to learner interaction, Learner to learner interaction. The following tools were assessed to enable the interaction for task completion: Annotation tools, Collaborative exercises, Polls, Feedback and Audio discussions.

### College of Engineering and the Built Environment

**Colin Caprani: School of Civil and Building Services Engineering**



Structural engineering brings mathematics and physics together to solve real-world problems, such as the design of bridges and buildings. Competent practitioners need to have an ability to physically interpret abstract mathematical models. Failure to be able to do so could have serious consequences for public safety. One solution is to expose engineering students to more physical experimentation than has been traditionally

included in courses. This project aimed to improve students’ physical interpretation of mathematical models through model-building, physical testing, and computer modelling. This improvement cuts across all course modules, and will reveal itself in improved student engagement with the subject-matter, with consequent improved outcomes.

## College of Engineering and the Built Environment

### David Dorran: School of Electrical Engineering Systems



**BASICS** - Building a System to Ingrain Core Competencies within Students  
The aim of the project was to develop a system which would promote a solid knowledge of programmes “core competencies” amongst students. This to be achieved by building a set of online quizzes which students will undertake on a regular basis throughout the delivery of programme modules.

Quizzes included feedback with links to web-based activities/information to help students develop their understanding. The anticipated benefits of the project are to promote understanding of core competencies, the development of eLearning expertise, re-use quizzes across programmes, promotion of vertical coherence within programmes, efficient feedback to students and to encourage self-directed learning

### Audrey Martin: School of Spatial Planning



**GeoLearn Multi Media Resources Project.** The objective of the GeoLearn Multi-Media Resources Project was to assess the potential of pedagogically designed video demonstrations in supporting the learning requirements of students in the Spatial Information Sciences. Currently, over 300 full and part-time students in the College of Engineering undertake a module in Land Surveying each semester in the area of practical land surveying techniques.

Students often experience difficulties when carrying out practical project tasks due to the relatively short one-on-one field demonstration time. Thus to enhance the students’ practical learning experience a number of short videos with voice over instruction have been developed. It is expected that evaluation of the use of videos in formal field assessments will inform future content development. The videos are intended as an enhancement rather than a replacement to the more traditional forms of demonstration and notes based instruction, and combined provide a multi-media approach to learning

## College of Sciences and Health

### Julie Dunne and Barry Ryan: School of Food Science and Environmental Health

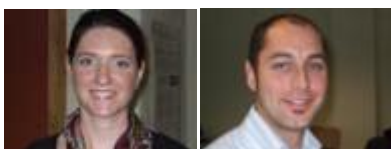

The aim of the project is to maximise the learning associated with undergraduate laboratories for first and third year students by redesigning and aligning assessments and teaching strategies, devising and implementing appropriate and timely feedback processes, and integrating transferable skills at key stages in the curriculum.

Through the incorporation of transferable skills, the redesign of assessment practice and the provision of effective feedback to students it is hoped that students will perform better in assessments, be better prepared for conducting their final year independent research studies, become more employable graduates and generally have greater satisfaction with the overall DIT learning experience.

### Michael Seery: School of Chemical and Pharmaceutical Sciences



The aim of this project was to develop pre-lecture resources for introductory chemistry lectures. The purpose of these resources was to reduce the cognitive load of novice learners in lectures by introducing new terms prior to the lecture, incorporate contextualised worked examples to stimulate interest in a topic and scaffold students problem solving skills and to provide immediate and targeted feedback to students so that they may identify areas of difficulty.

As a result of the introduction of these pre-lecture resources, the format of the lecture changes, by incorporating a discussion on areas of difficulty into the start of a lecture. The advantage of moving to an online system is that feedback can be immediate and customised to individual student’s difficulties.

## **College of Applied Arts and Tourism**

# Using Formative Feedback to Support a Blended Learning Programme

Noel Fitzpatrick, Bernadette Burns and Brian Fay,  
School of Art, Design and Printing

Contacts: [Noel.Fitzpatrick@dit.ie](mailto:Noel.Fitzpatrick@dit.ie), [Bernadette.Burns@dit.ie](mailto:Bernadette.Burns@dit.ie), [Brian.Fay@dit.ie](mailto:Brian.Fay@dit.ie)

## Abstract

Formative feedback has been well documented as a means of promoting and engaging learning. Indeed, for effective feedback the timely nature of feedback is essential. This project outlines the development of formative assessment as integral part of a blended learning programme. Using the existing BA Visual Art Programme (Sherkin Island), this project developed, used and evaluated innovative student feedback mechanisms. The project focused on the development of formative feedback for first year modules on the programme with special emphasis placed upon the written elements of the course. The BA in Visual Arts is a majority practice based programme in Fine Art with Painting, Drawing, Sculpture and Multi Media. The cohort on the course is mainly adult mature learners returning to higher education or attending higher education for the first time. The Critical Theory module, which is predominantly text based, poses therefore a challenge for these students; typically a percentage of students present with anxiety around written aspects to the programme and, in addition, there are a certain number of students with dyslexia. This project outlines how the introduction of formative feedback could be used to allay the fears around assessment and in particular the assessment of the written elements to the Critical Theory Modules.

**Keywords:** assessment criteria, formative assessment, peer assessment, feedback, feedback grid, timely nature of feedback

## Introduction

This project aimed to introduce students and staff on the programme to formative assessment as a means of enhancing student learning and engagement. The project aimed also to explore different aspects of feedback. The hope was that through the use of structured formative feedback the students would have a better understanding of what was being assessed and therefore gain an insight into assessment as part and parcel of the learning process and not something which is often perceived as distinct from the learning process. In Fine Art teaching students and staff are well accustomed to the use of “crits” as a mechanism of learning and the extension to Critical Theory was, it was felt, a natural progression. The BA in Visual Arts is delivered in a blended learning format with either face to face seminars or webinars held every six weeks. The Critical Theory modules are delivered principally through virtual seminars and focus on contemporary critical theory with a particular emphasis on French Theory, i.e. post-structuralist philosophers, semiotics and postmodernist critical/literary theory. This represents a challenge to any student studying contemporary art.

## Outline of the Project

In order to focus on the assessment of Critical Theory it was decided to start by looking at assessment in general and then to explore particular methods of feedback in relation to Critical Theory. To this end it was necessary to explore all aspects of assessment and to gain a clear understanding of what was being assessed, how and when.

It was decided to treat assessment as a specific part of the student induction process and “assessment” was presented during the student induction of the new first year cohort. In September 2010 we met with the students during induction to present our research project to the students and staff teaching on the course. The format of the presentation was a short introduction to assessment

in higher education and then a group discussion around any issues that they might have in relation to assessment. The students were then presented with the assessment schedule for Critical Theory and the feedback process.

The second step in October 2010 was a weekend workshop organised around assessment with students from the first and third year of the programme and some members of staff teaching on the programme. The session was facilitated by Dr Jen Harvey. The weekend was structured around assessment of the programme in general. The students were given the opportunity to discuss assessment and the feedback grid. The discussion was very lively and a number of interesting issues were raised, in particular, around peer assessment and group assessment. There was a certain resistance to the idea of assessing each other's work; the comment was *Who am I to assess other students? That is your job (as teachers, that is what you are paid for)*. The group members were set a particular task (to construct a temporary piece of art at a specific location on the island); they then had to assess each other's participation in the group activity and then to assess each group's work. The overall group was asked to develop a mechanism of assessment and feedback for the evaluation of each smaller group. The School of Art, Design and Printing uses a specific feedback sheet and in the end the overall group developed a similar one (see Appendix C). The weekend workshop gave real clarity for staff and students about the terms and criteria used to assess the students work; this proved to be very beneficial throughout the year.

After the workshop, Dr Noel Fitzpatrick during his seminars on Critical Theory discussed the assessment of the Critical Theory module with the students at the end of October. This module is a 10 European Credit Transfer System (ECTS) year long module and offered the opportunity to explore feedback in the first and in the second semester. The module had the following assessment schedule.

- 1) Week 6 (Formative Assessment)
  - a. Feedback within 2 weeks
- 2) Week 15 (First Semester Assignment)
  - a. Feedback within 3 weeks
- 3) Week 6 (Formative Assessment)
  - a. Feedback within 2 weeks
- 4) Week 15 (Second Semester Assignment)
  - a. Feedback within 4 weeks

Each term on the assessment form – research, analysis/development, evaluation/structure and presentation – was discussed with the group during the live link ups. It was decided to give the students the opportunity to avail of formative assessment, once in the first semester and once in the second. The students were given the opportunity to submit 500 words for formative assessment on Week 6 of the semester; 16 of the 19 students submitted the formative feedback assignment. The assignments were not graded but were given feedback under the headings of the assessment form. The students were given this feedback within two weeks of the submission date. The students received annotated feedback in the form of an email. The email contained a general comment about the work while the attached Word file contained detailed feedback embedded in the assignment. At the next session, in Week 8, Dr Noel Fitzpatrick gave overall feedback to the group about the assignments.

For the first formative assessment feedback the main problems of the assignments were under the research and presentation headings; in short the students had not engaged enough with the primary and secondary readings and had not referenced the material correctly. The students then submitted the final assignment for the first semester. There was a marked improvement in the performance, and the students had incorporated to a large extent the feedback comments given. However, three



students did not submit for the final assessment nor for the formative assessment. In the second semester the process was repeated. In the second semester the material covered in the live link ups was felt by the students to be much more challenging. The number of students availing of the formative feedback was slightly lower, 15 and the number of students who did not submit a final assessment was higher, 6. These students were referred and were to submit in September 2011. However, it was decided to meet with these students in June. We teamed with the students to discuss the assignment of the second semester and general feedback was given on the students' work submitted. In the second semester the areas where the group needed improvement were found to be in analysis/development and structure/evaluation. The major issues were that the overall logic of the assignment needed to set much more clearly, and also that there was a lack of evaluation of the resources used.

### **Lessons Learned**

The introduction of formative feedback has been successful from a number of points of view. It has enabled the staff and students to come to a common understanding of the assessment criteria. The students who chose to avail of the formative feedback clearly benefited. However, there is a certain disappointment in relation to the students who did not engage with the process, all of whom were referred over the summer. Within the group of students referred two clearly have major writing difficulties. It had been hoped that the process of formative feedback would have enabled the students to gain confidence in the assessment process; however, this was not the case. It also became clear that the formative feedback process itself was very time consuming for the tutors; the use of a grid of comments would have been more efficient and effective. This is particularly true in relation to the early feedback in first and second year where a lot of the comments are generic. The use of a grid would have also ensured the timely nature of the feedback.

The evaluation of the project took place through a number of meetings with the students at the beginning and at the end of the year. There was general agreement amongst the students that workshop on assessment and formative feedback forms were very useful. However, they also mentioned the need to explore other methods of assignments, for example a learning portfolio or aural/recorded submission. A paper will be submitted to the next Learning Innovation Network (LIN) conference on the general findings of the project.

### **Recommendations**

The scale of the project was too small to lead to general recommendations for the Institute. Nonetheless, there are a number of aspects that could be considered for generalisation.

- 1) The presentation of assessment as part of the induction programme
- 2) Specific workshops on assessment to be held with the students and staff
- 3) The use of formative assessment grids for feedback
- 4) The use of a template of comments for student feedback

### **Future Developments**

Further developments would be the establishment of templates for feedback for staff teaching the same modules. For example in Critical Theory there are a large number of students, and formative feedback in a timely manner is challenging considering the volume of work to be corrected.

## Further Reading

Boud, D. (1990) Assessment and the Promotion of Academic Values. *Studies in Higher Education*, 15 (1), 101–111.

Gibbs, G. (1999) Using Assessment Strategically to Change the Way Students Learn. In Brown, S. and Glasner, A. (eds) *Assessment Matters in Higher Education: Choosing and Using Diverse Approaches*. Buckingham: Open University Higher, pp. 41–53.

Gibbs, G. & Simpson, C. (2004) Conditions under which Assessment Supports Student Learning. *Learning and Teaching in Higher Education*, 1, 3–31.

Stiggins, S. (2002) Assessment Crisis: The Absence of Assessment for Learning. *Phi Delta Kappan*, 83 (10), 758–765.

Yorke, M. (2003) Formative Assessment in Higher Education: Moves Towards Theory and the Enhancement of Pedagogic Practice. *Higher Education*, 45, 477–501.

# The Correlation between Attendance and Achievement

Adrian Davis,

School of Hospitality Management and Tourism

Contact: [adrian.davis@dit.ie](mailto:adrian.davis@dit.ie)

## Abstract

In a global context it is generally accepted that the retention and associated completion rates for first year students is an area for concern in third level institutions. One area of particular interest is the low levels of completion on some degree programmes. Earlier studies of a similar nature have indicated that those students who attend at high levels not only pass examinations but also attain higher grades. Whilst attendance itself is not the cause of learning, even the most basic exposure to new material has a positive effect on learning.

The purpose of this study is to ascertain the correlation between class attendance and academic success. The cohort which is the focus of the study is a group of first year undergraduate students participating in a three year BA Hospitality Management degree. The findings suggest a positive correlation between attendance and academic achievement at first year level. The data also reveals a higher attendance rate for those subjects with an element of compulsory attendance. Attendance was found to decline over time while prior high academic achievement was not a strong predictor of success at the first year level of higher education.

**Keywords:** pilot study, progression, compulsory attendance, mature students

## Introduction

The aim of this project was to determine the correlation between class attendance and academic achievement at the end of the academic year 2010/2011, for a group of first year students. Through data collected during the year, the relationship between attendance and achievement was determined. The data was collected over two 12 week teaching periods for both semesters during the academic year. On average the modules are weighted 40% assessment and 60% written examination. Additionally, certain modules have a mark allocated for attendance. According to Colby attendance is the main driver of academic success (Colby, 2004) therefore, as the data were being analysed, they were also used to inform students about their attendance with a view to improving future attendance.

Previous research has indicated a positive correlation between attendance and academic achievement. In a five year study Burd and Hodgson (2004) concluded that their results showed a significant correlation between attendance and attainment at third level. A study conducted by Newman-Ford, Lloyd and Thomas (2008) concluded that prior educational attainment and attendance were significant predictors of attainment. Similarly, Wigley (2009) found that there was a clear relationship between attendance and achievement in a study conducted at a college in the United Kingdom.

A study comparable to the current project had already been piloted at the Dublin Institute of Technology by the institute's retention officer, Mark Russell. For the duration of this study, which was conducted on the same degree programme as the present study, the programme tutor collected the data and the retention officer contacted and interviewed those students whose attendance had fallen to an unacceptable level. According to Russell, for many of the students interviewed there was an immediate improvement in attendance (Russell, 2010). The findings of the pilot study suggested an increase in progression rates from 21% for the previous academic year, to almost 80% for the academic year 2009/2010.

## Outline of the Project

The current study was designed to be conducted entirely by the researcher, who is also the programme tutor to the class. The rationale underpinning this approach was that, if the process proved successful, it could be replicated by other tutors without support. The effort of coordinating the data collection process, entering and analysing the data, and contacting students proved to be a time-consuming and tedious task for the tutor working without assistance.

### *Details of the Cohort*

The group of students who were the subject of the study was a cohort of first year students taking a BA Hospitality Management degree at the School of Hospitality Management and Tourism, Dublin Institute of Technology. The modules are taught via lectures, tutorials and/or practical sessions. The academic year is split into two semesterised halves, one running from September to December and the other from January to May. Examinations are held at the end of each semester, with the opportunity to repeat the following September. On successful completion of a module the student is awarded five European Credit Transfer System points (ECTS). For logistical reasons, seven modules are completed during the first semester and six during the second semester of the academic year.

## Methodology

### *Design*

This is essentially a correlation design, which measures the strength of the relationship between student class attendance and examination achievement. Attendance at tutorials was not included in the study as the significant additional workload involved in data collection and analysis was deemed to be too burdensome. A Pearson product-moment correlation was applied to the data which reflects the degree to which two variables are related.

### *Participants*

The sample consisted of 40 first year students who were participating on a BA Hospitality Management degree programme at the School of Hospitality Management and Tourism, Dublin Institute of Technology. Due to some students withdrawing from the programme at the end of the first semester, the sample was reduced to 36 students for the second semester.

### *Data Collection Procedure*

With the agreed participation of all staff lecturing to the group, attendance data were collected by each lecturer during class and submitted to the researcher immediately following the class. The data were then entered into a pre-designed electronic spreadsheet by the researcher. On average, each student was monitored over 13 modules resulting in 6,240 individual data entries. The results and attendance for those students who left the programme during the year were not entered as the aim of this study was to investigate the correlation between examination results and achievement.

### *Data Analysis Procedure*

The examination and attendance data were analysed following the examinations held in January and May. The results for supplemental examinations were also entered and analysed in September, as the aim of the study was to examine the performance over one entire academic year, which included all three examination sessions.

### *Contacting Students*

With the expectation of encouraging attendance, students whose attendance had fallen below an acceptable level were contacted during the semester. This level was determined by the researcher as those students who had missed two consecutive teaching sessions. Students were contacted in person, using e-mail initially and if necessary mobile telephone. This process served the purpose of

encouraging most students to return to class immediately, otherwise it offered an opportunity to discuss any relevant issues with students on an individual basis.

#### *Data Collection Shortcomings*

Involvement in all aspects of data collection and analysis procedures by one individual proved to be a time-consuming task. Throughout the study it was necessary to coordinate collection of attendance sheets from 26 lecturing staff in total. Not all participating lecturers remembered to return the completed attendance sheets as requested, resulting in considerable effort being expended on tracing missing records.

Additionally, when a lecture was cancelled, adjustments had to be made to the analysis tool to ensure accurate computation of results. Furthermore, the plan to contact students within the suggested time-frame was not always adhered to; this resulted in some students missing up to four classes before any corrective action was taken.

### **Main Findings and Discussion**

During Semester 1 there was a strong effort put in by the majority of students to attend class regularly. The overall attendance percentage during this period was strongly influenced by the small minority of students who were particularly poor attendees, these (4) students did not subsequently participate in Semester 2. One notable aspect of the findings was that the classes which had the highest attendance were also those which had marks allocated for attendance. A number of students who were not attending at the required level were contacted during the semester and in most cases their attendance subsequently improved. The attendance levels attained during Semester 1 were not duplicated in Semester 2 as attendance levels decreased. This may have been caused by the lack of formal contact with the programme tutor, who was teaching the group during the first semester but not during the second semester. The only contact during this period was when the tutor made arrangements to meet the group, on these occasions not all students attended. Also, the three modules which had marks allocated for attendance were taught during Semester 1. The average overall attendance for all students was 61%.

	<b>N</b>	<b>Minimum</b>	<b>Maximum</b>	<b>Mean</b>
<b>Total Attendance %</b>	36	14	100	61
<b>Semester 1 Attendance %</b>	40	23	100	65
<b>Semester 2Attendance %</b>	36	14	89	56

**Table 2.1: Attendance**

#### *Attendance Patterns over Time*

Results are also presented in Table 2.2 for the average attendance for the duration of each semester. At the beginning of each semester, between 70% and 80% of students were attending, but by the end of each semester that figure had fallen to a little over half. The pattern of attendance shows a decline in line with other programmes at the school. This is from anecdotal evidence regarding current programmes. It has been suggested by staff participating on the programme that, generally, there is a fall-off in attendance as soon as projects have been submitted; this is normally around the sixth week of the semester.

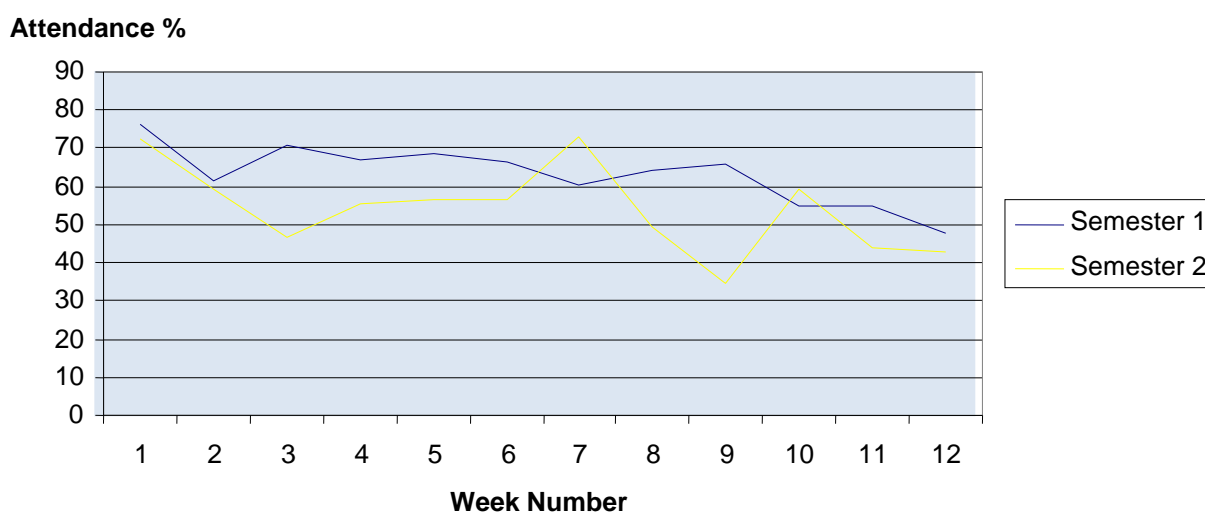

**Table 2.2: Attendance over time**

Previous studies have indicated that attendance declines as the semester progresses (see Dolnicar et al., 2009: 204 for more details.). The current study supports this assertion as attendance declined as both semesters progressed.

#### *Attendance and Examination Results*

A Pearson correlation test was performed on the aggregated attendance and examination results. The overall results indicated a significant positive correlation of linear  $R^2 = .541$ . Similar tests were performed on the results for each module and all returned a positive correlation between attendance and academic achievement. The association was particularly strong for those modules which had marks allocated for attendance. The results emphasise that, for students to pass examinations, regular attendance at lectures is essential.

Of the total number of students who completed the year (36) there is a division in attainment between those students who maintained an attendance percentage of greater than 60% and those that did not. Those students who maintained an average attendance of above 60% achieved an average mark of 59%. Those students who maintained an average attendance of 60% or below, achieved an average mark of 46%. Only 11 students passed all modules at the end of the academic year (31%), the remainder were required to repeat at least one subject in September. The average attendance of these students who passed all modules was 71%, while the average attendance of those who were required to repeat more than one module in September was 61%.

#### *Supplementary Findings*

Anecdotal evidence suggests that prior academic achievement should have a bearing on academic performance at third level. Based on individual student's Central Applications Office (CAO) points, the correlation with final marks was investigated. The results indicated a positive correlation of linear  $R^2 = .038$ . Although not a strong correlation, this suggests that caution should be exercised when determining at what CAO points level students should be admitted to the programme. The data also indicated that 75% of students who selected the programme as a fourth preference or less had left the programme before the end of Year 1.

#### *Progression Rates*

This degree programme was selected for the attendance monitoring study due to a decline in student progression rates from first year. The decline in progression rates was noticed following

examination of the annual pass rates. Also, since taking responsibility for the programme the co-ordinator was motivated to initiate the study by his personal experiences as a participant on a similar programme many years earlier.

The criterion for assessing the success of the programme from a retention perspective was the improvement in student progression rates. See Table 2.3.

### % Students Progressing

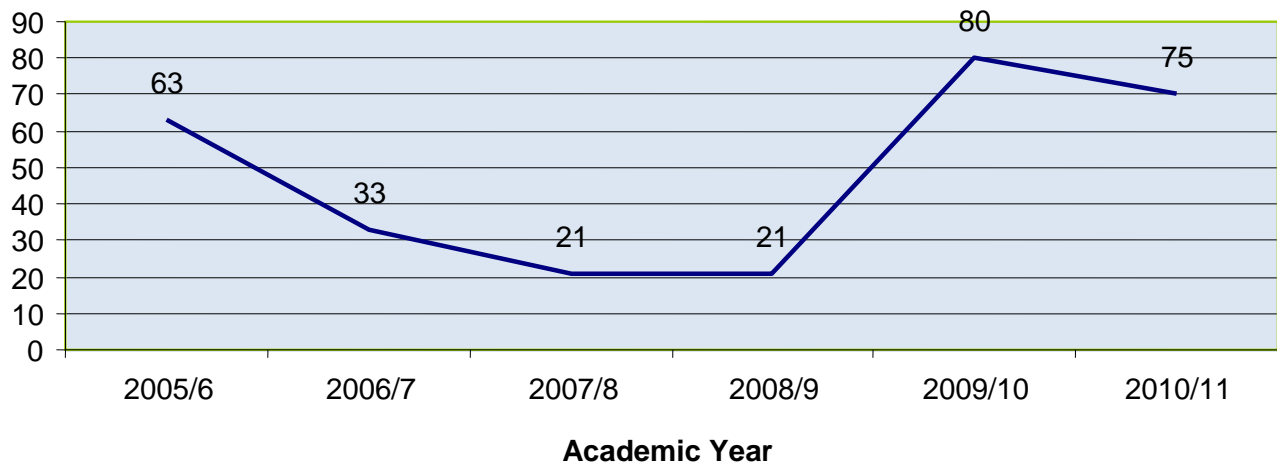

**Table 2.3: Historical progression rates for first year**

The average progression rates for the four academic years prior to the pilot study of 2009/10 was 35%. The average progression rate for the academic year during which the study was maintained was 75%. The results suggest an increase in the progression rate of 210%. It is assumed that this dramatic increase is in some way due to the attendance monitoring study and the encouragement given to those students who had started to exhibit poor attendance habits during the year.

#### *Compulsory Attendance*

Research from the 1990s suggests that students were more likely to attend if attendance was compulsory. The results of the current study suggest that those modules which had some element of attendance allocated marks also had the highest attendance throughout the module. This is supported by Devanoss and Foltz (1996) who suggested that students were more likely to attend if attendance was compulsory. Three of the Year 1 modules taken by students had some element of compulsory attendance integrated into the subject. The average attendance across these modules was 76%, this is 24% above the class average of 61%. This indicates that, perhaps, the Institute should consider introducing an element of compulsory attendance across modules in a drive to increase attendance.

#### *Non-Progressing Students*

Ten students failed to progress to Year 2 of the programme. The average attendance of these students was 51.5%, which equates to 15% below the average attendance of the entire class. This finding indicates that there is a relatively slim margin between the attendance percentage of those who progress and those who do not. Therefore, it is suggested that there is limited leeway for students who do not maintain at least the average attendance.

#### *Mature Students*

Five mature students participated in the first year of the programme. A mature student is defined as one who is 21 years of age or above. The average attendance percentage for mature students was

79%, and they passed all modules at the first attempt. Their average mark was 67%, compared to 56% for the cohort as a whole. This supports the contention that those students who are not in this category should be encouraged to behave in ways which are conducive to achieving success during their participation in third level education.

### **Project Evaluation**

This project was evaluated through the measurement of the increase in the progression rate to Year 2 of the programme. The progression rate for the current cohort of students is 75%. The success of the study can be measured by the dramatic increase in the progression rate achieved. In addition to the main aim of the study, the project offered a noteworthy opportunity to further mine the data for additional relevant information. These findings have already been discussed in the previous sections.

For the duration of the study the researcher presented the interim findings at a number of presentations and workshops (see p. 57). Also, the study will be presented at the International Conference for Education Research and Innovation (ICERI).

### **Conclusions**

This study was conducted with a particular focus on first year students. The findings support anecdotal evidence that there is a significant positive correlation between class attendance at lecture sessions and academic achievement. The study also reveals that there is, amongst this cohort, a less significant positive correlation between prior academic achievement and success at third level. Attendance declines as the semester progresses.

Given the lower attainment associated with the lack of attendance it may be necessary to take steps in assisting these students to better engage in the learning process. On average, the data suggests that individual students have different results, which are generally dependent on their attendance patterns. Also, the findings suggest that to pass modules at the first attempt, students should attend a minimum of 60% of lectures during each semester. The findings also suggest a more personal approach when addressing the issue of poor attendance. When contacted, students cited a range of reasons as to why they had missed lectures. In some cases, attendance improved for a while but then decreased again. A hard-core of non-attending students was identified and, despite efforts on behalf of the tutor, little was done to improve their attendance. If a student is missing from two lectures, particularly at the beginning of the semester, action should be taken immediately to encourage a return to class. A case exists for the introduction of some element of mandatory attendance. Finally, the findings reveal a significant difference between the attendance patterns of students who have progressed directly from second level education and those mature students who have entered the programme at a later stage of their careers.

### **Recommendations**

The findings of this study will be useful for shaping institutional and national policy and practice on the topic of student attendance monitoring. Therefore the following recommendations are made:

1. Present a summary of the findings to each group of students beginning first year. The presentation should act as a motivator and encourage students to maintain a high level of attendance throughout the academic year.
2. Establish an attendance monitoring system with the aim of identifying those students who are indicating patterns of poor attendance from the beginning of the semester. Take action to address the issue at the earliest possible opportunity.



3. Introduce an element of compulsory attendance across all modules in a drive to increase attendance.
4. Appoint a Student Liaison Officer to monitor attendance data and take relevant action across all programmes at the School of Hospitality Management and Tourism.

### Proposed Future Research

This study has focused on attendance as being the most important criterion for academic success. However, attendance is but one manifestation of deeper issues relating to student engagement in third level education. The proposed future work will be to conduct a longitudinal study focusing on student engagement across various dimensions relating to participation in third level education.

### References

- Burd, E. and Hodgson, B. (2004) *CETL – Active Learning in Computing*, University of Durham.
- Colby, J. (2004) Attendance and Attainment – A Comparative Study. Paper presented at the 5<sup>th</sup> ICS-LTSN Annual Conference, University of Ulster, 31 August to 2 September.
- Dolnicar, S., Kaiser, S., Matus, K. and Vialle, W. (2009) Can Australian Universities Take Measures to Increase the Lecture Attendance of Marketing Students? *Journal of Marketing Education*, December, 31: 203–211.
- Newman-Ford, L., Lloyd, S. and Thomas, S. (2008) An Investigation Into the Effects of Gender, Prior Academic Achievement, Place of Residence, Age and Attendance on First-Year Undergraduate Attainment, *Journal of Applied Research in Higher Education*, 1 (1), 14–28.
- Russell, M. (2010) *Pilot Electronic Student Attendance Monitoring Report*, Dublin Institute of Technology, Dublin.
- Wigley, S.C. (2009) The Relationship Between Attendance and Academic Performance in Further Education College A/S Psychology Students, *Journal of Further and Higher Education*, 33 (2), 183–190.

**College of Engineering and the Built Environment**

## Towards an Improved Teaching of Structural Behaviour

Colin Caprani,  
School of Civil and Building Services Engineering

Contact: [colin.caprani@dit.ie](mailto:colin.caprani@dit.ie)

### Abstract

The interpretation of mathematical models and how they relate to the physical world is a key skill of the practice of structural engineering. At undergraduate level, there has been a noted reduction in students' physical intuition in recent years. The teaching of structural engineering must therefore adapt itself to these new realities to maintain public confidence in the safety of society's infrastructure.

The work carried out for this Fellowship project tackled the identified deficits at two ends of the spectrum of physical intuition. Third year students were introduced to basic structural models, whilst final year students were exposed to the inner workings of structural engineering software so that they may better link their hand calculations and typical commercial software. Pre- and post-testing using multiple choice questions were used to ascertain the effectiveness of the interventions. The results are generally inconclusive as evidence was found that the multiple choice questions may not be the best form of assessing interventions in physical reasoning. It is clear that more work remains to be done in this area.

**Keywords:** structural engineering, structural behaviour, physical intuition, multiple choice questions

### Introduction

Structural engineering brings mathematics and physics together to solve real-world problems, such as the design of bridges and buildings. A core competency of its practitioners is therefore an ability to physically interpret abstract mathematical models. Failures to do so have serious consequences for public safety.

In the teaching of structural engineering (course DT024), there is an increasing disconnect noted between the mathematical models used, and the physical interpretation of results. This could be arising from reduced tactile experience in childhood: for example, a recent class survey found only about 4% of students had ever built a tree-house. Ironically, this is happening as computer modelling has become standard in the practice of structural engineering. This is exacerbating the problem, as improper understanding of the physical implications of the models used in computer software can lead to structural failures (and already has). It therefore falls to teachers of structural engineering to expose students to more physical experimentation than has been traditionally included in courses.

It should be noted that this problem is not unique to DIT, but is extensively documented for UK institutions in particular. The Institution of Structural Engineers has introduced an annual academic conference to address this problem, and many papers and reports have been prepared (see Further Reading section).

### Outline of the Project

This work aims to improve students' physical interpretation of mathematical models through model-building, physical testing, and computer modelling. Such an improvement will cut across all course modules, and should reveal itself in improved student engagement with the subject-matter, with consequent improved outcomes.

### Interventions

There is a spectrum of physical intuition that runs from a very basic ability to predict the physical outcome of very basic actions (such as, “if I stand on this plank it will bend”), to the interpretation of numerical models and what their answer means in the physical world (such as, “a negative value for the support reaction does not make sense here as the plank is not trying to lift”). This work intervenes at both ends of this spectrum.

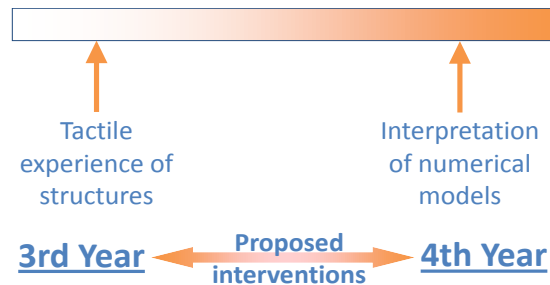

**Figure 3.1: Spectrum of intuition and interventions**

#### *Third Year Intervention (DT024/3)*

Third year students of structural engineering were sequentially exposed to physical model building, basic computer modelling, and interpretation of basic mathematical results. In this order, it was hoped that the student would link from the physical behaviour of structures, towards the mathematical modelling thereof. Figure 3.2 shows how the abstract classroom models were brought to the physical world and investigated by the students. The work programme culminated with a group project combining all three aspects, with associated presentation, calculation, and physical testing: the Spaghetti Bridge Competition.



**Figure 3.2: Early-stage building of physical intuition of structural behaviour**

#### *Fourth Year Intervention (DT024/4)*

Fourth year students were introduced to bespoke educational software (*TrussMaster* – see [www.colincaprani.com](http://www.colincaprani.com)) that exposes the “black box” calculation steps of standard engineering analysis programs in a way that links directly to the traditional lecture material and basic calculations carried out in class (Figure 3.3). Having linked the class material and software calculations together, the students examined a range of sample problems using the software, some of which are physically unreasonable, and also carried out hand calculations on same. Through exposure to both “good” structural modelling and selected sample “bad” structural modelling, it was hoped that the students would link from numerical modelling towards physical intuition.

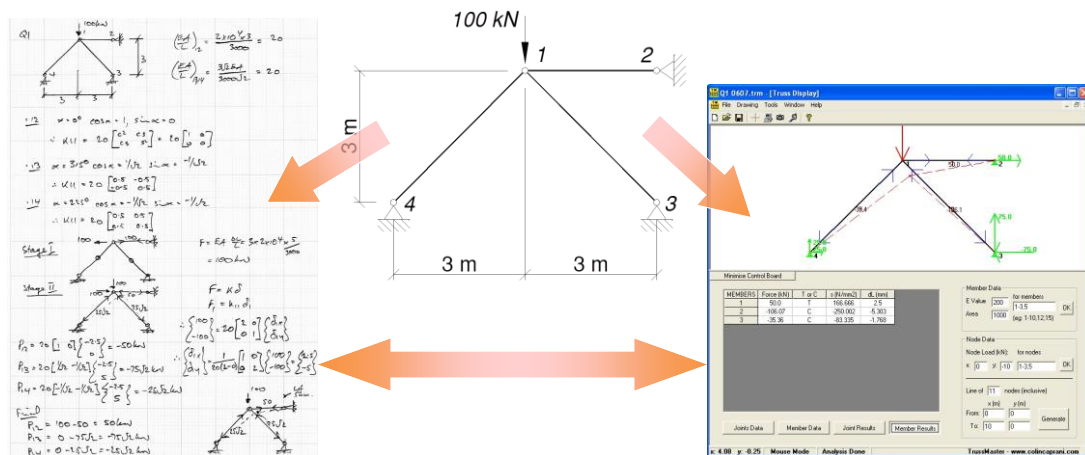

Figure 3.3: Late-stage interpretation of numerical models

### Assessment of Interventions

The effectiveness of the two approaches outlined was measured using pre- and post-testing. A novel feature of this work (at least in structural engineering education) was the use of multiple-choice questions (MCQs) for the testing. The project effectiveness will also be measured qualitatively through student focus-groups.

For each intervention, 15 MCQs were to be answered in 15 minutes. Each question had three options, and the very same test was used for both pre- and post-testing. This was possible as the students were not allowed keep the question sheet. A standard gain analysis was then implemented for each student:

- Let  $P1$  = pre-test score;
- $P2$  = post-test score;
- Scope =  $100 - P1$  (i.e. the scope for the student to improve);
- Gain =  $P2 - P1$  (the actual gain in score);
- Improvement = Gain/Scope (a percentage measure of improvement).

### Results and Analysis

Histograms of marks, gain (i.e. change in marks), and improvement are shown in Figures 3.4 and 3.5. From these figures it can be seen that for both classes there was an appreciable gain in marks and improvement in knowledge. This is certainly to be expected. However, there are several important features of these results that require further explanation:

1. Figure 3.4(a) shows that the pre-test marks for both interventions were too high. It is typically expected that before a concept is taught, a pre-test mark should score quite low, perhaps around 20-30%. In the cases here, the average marks are about 60–70%. This means that the tests were not a stringent enough assessment of conceptual understanding.
2. Figure 3.5 shows that there is an improvement averaging around 40% for both groups. However, several students show negative improvement and scored less in the post-test than in the pre-test. In one case, a student showed a complete negative improvement (i.e., the student got no questions correct both times).

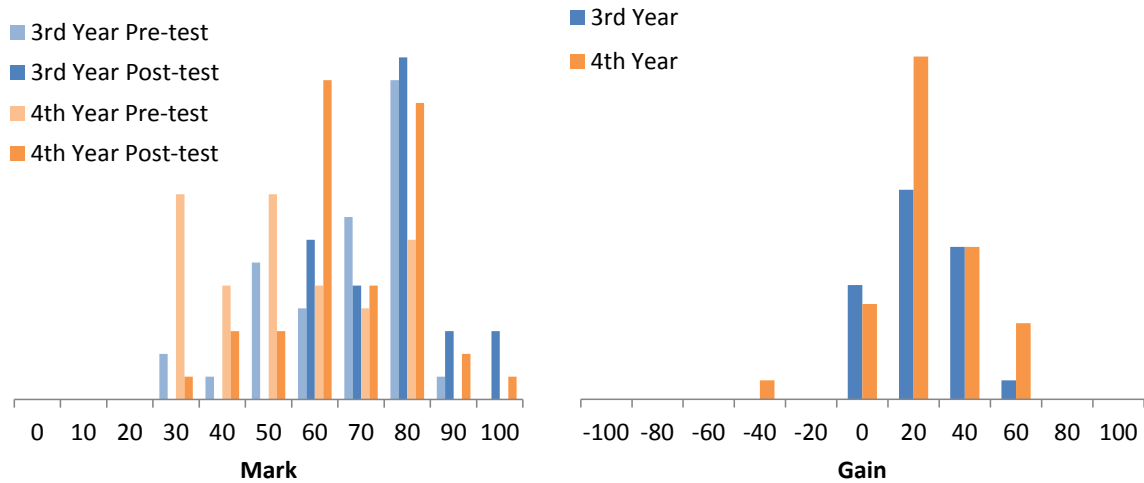

(a) Pre- and post-test marks;

(b) Change mark between pre- and post-test marks;

**Figure 3.4: Histograms of MCQ diagnostics**

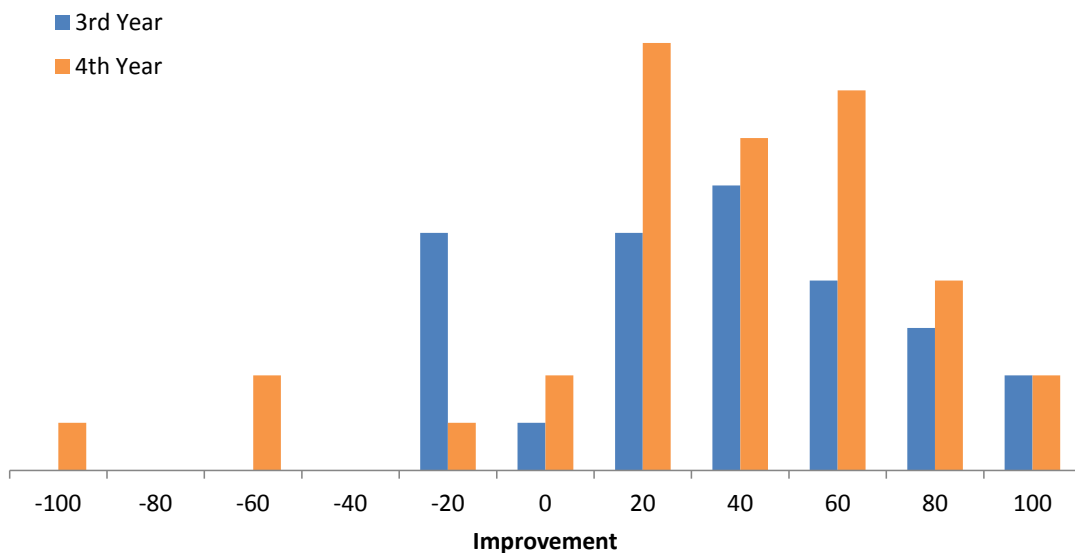

**Figure 3.5: Histograms of student improvement**

### *Deeper Analysis*

As a result of the unusual pattern of results observed, a detailed analysis of the MCQ results was developed. This analysis is based on the premise that material that is truly known and understood by the student will be answered correctly in both the pre- (P1) and post-testing (P2). This analysis requires that the answers for individual questions be compared across both tests, and thus is only valid when the pre- and post-tests are the same. (However, it is possible to extend this once the same concepts are examined in a particular question number.) The analysis is as follows:

- P3 = score of questions that were answered correctly both times;
- $P1r = P1/P3$ , ratio of pre-test score to P3 (should be 1.0);
- $P2r = P2/P3$ , ratio of post-test score to P3 (should be 1.0 or more);
- Guess Index:  $GI = (P1r-1) * P2r+1$ , this should be 1.0 if no guessing occurred;
- Performance Index:  $PI = 0.5 * (P1 + P2) / GI$ , a 40% PI is pass.

The results of this deeper analysis are shown in Figure 3.6 below. It can be seen that there is strong evidence of guessing. A guess index of 1.75 indicates that the answers to half of the questions were guessed. As can be seen most students score a GI between 1.0 (no guessing) and 1.75 (50% guessing), with some students scoring far higher (one guessed all questions).

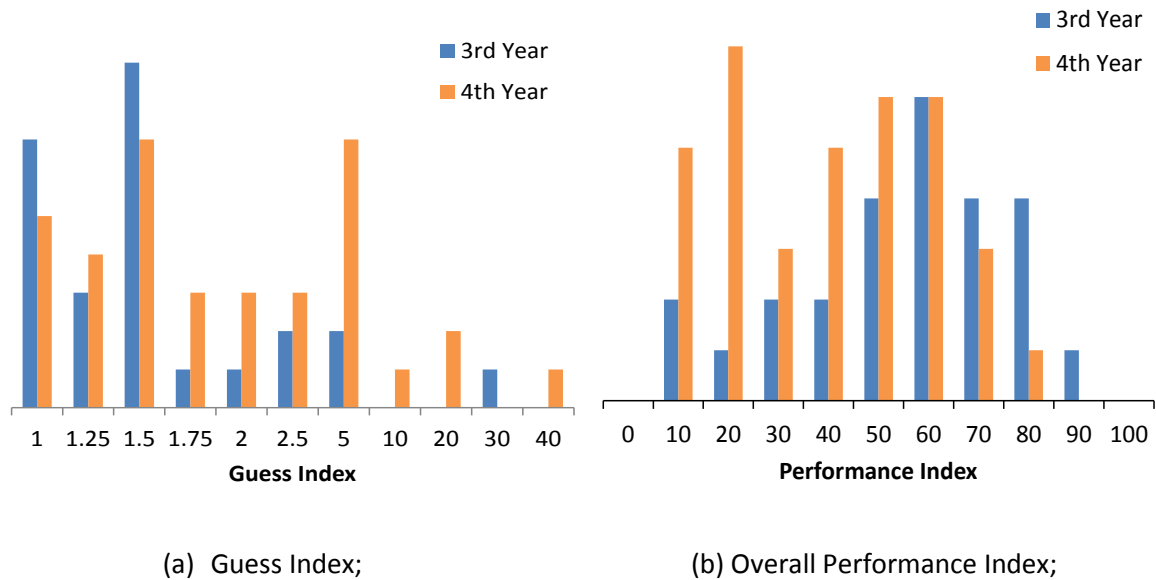

**Figure 3.6: Histograms of MCQ diagnostics from deeper analysis**

In calculating the Performance Index, the Guess Index is used, and so there is an induced dependency between the measures (of exponent -1.0). However, it is still of interest to see if a student's overall performance is related to the amount of guessing carried out that differs to an exponent of -1.0. To this end, each student's GI was plotted against their PI, as shown in Figure 3.7. It is quite clear from this plot that there is a larger than expected negative correlation for the 3rd years (-1.24), and a smaller than expected correlation for the 4th years (-0.2). Thus there is a relationship between performance and guessing, independent of that induced by the metrics used.

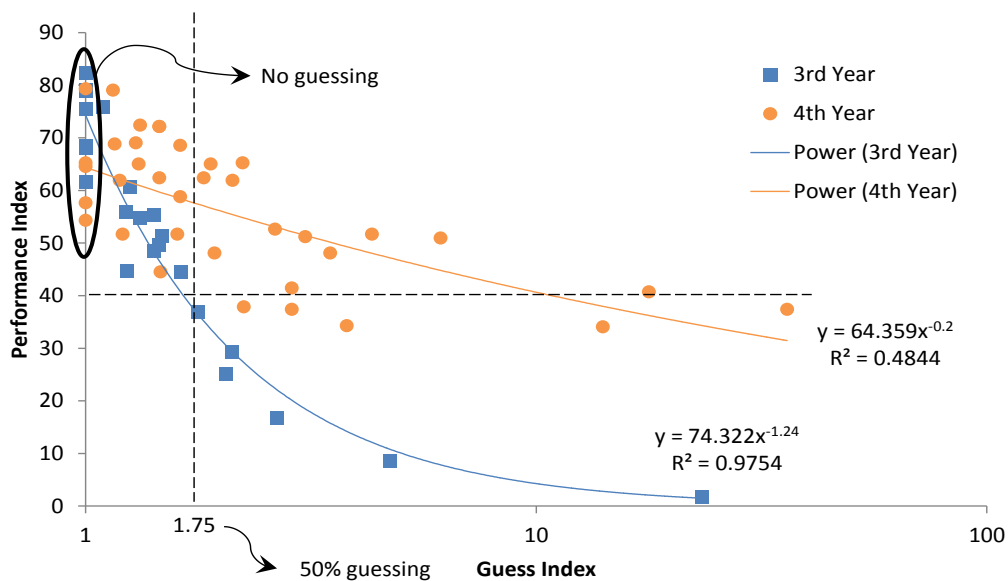

**Figure 3.7: Correlation between Guess and Performance Indices**

From the preceding analysis, it can be concluded that students who guess tend to score less. Of course, it must be realised that the students tested are rational and respond appropriately to the incentives put before them. That they guessed in the testing is therefore a fault of the testing arrangements, and not necessarily reflective of any attempt to deceive on the students' part.

### *Qualitative Results*

The results given so far are solely quantitative. Students' perceptions of the pedagogy undertaken is extremely important, as development of a passion for the subject is critical, yet may take longer to reveal itself. To this end, a randomly selected focus group from each class group was interviewed anonymously by the College Head of Learning Development. The resulting reports are extremely informative, and have already assisted, in liaison with the external examiners, in agreeing detailed changes to the syllabus over second through to fourth year.

In particular, the main findings from the third year focus group were:

- The students felt that a number of the questions could be simply answered by eliminating some of the answer options which they felt were not very realistic and therefore a proper understanding of the concepts was not required to answer some of the questions.
- For the students, the pre-test did reveal the gaps in their understanding, even if their score did not reflect this level of understanding. This helped them to assess their own level of understanding and recognize areas that they needed to work on.
- Overall the students felt the test was too easy and that a thorough understanding of the module content was not really required to do well in the test.
- The students enjoyed the module and appreciated the different learning activities. The projects helped students to link theory to practice, and they spoke of the positive aspects of being able to actually build a model and see the theory in practice.

And the main findings of the fourth year focus group were:

- The students believed that the way negative marking was used encouraged them to guess, even when they were reluctant to do so.
- The students felt that the "phrasing of a number of the questions was ambiguous", i.e. they were unsure of what they were being asked to do or solve.
- The questions in the pre-test were primarily assessing the knowledge covered in the first six weeks (i.e. in the lectures) and not what was "covered" in the second section. Therefore, although the students believed the software had helped them to learn and reinforce the knowledge and understanding from the lectures and notes, they did not feel that this would be reflected in the second test.
- The students were aware that the purpose of using the software was to enhance their learning and reinforce their understanding and felt it was an ideal tool to help them study.
- Overall the students were happy with the module and felt the pedagogy was effective. Positive aspects of the lectures include a high level of interaction (both student-lecturer and student-student), problem-solving opportunities, and the lecture notes (also available from the lecturer's website).

### **Project Evaluation**

Based on both the quantitative and qualitative results, a good improvement generally was shown both in actual marks, but also in conceptual understanding and appreciation of the subject. However, given the interesting results regarding guesswork, it seems that MCQs may not be suitable for the problems at hand. At a minimum, both third and fourth year groups agree that the questions should be redesigned for future use to remove obvious answers and to clarify exactly what is being asked. The fourth year group finding that MCQs with negative marking incentivised guessing is not consistent with established pedagogical findings. This is worthy of further exploration.



Throughout the process, good effort was put into explaining to the students the purpose of the tests. It was made clear that the tests were not to evaluate their knowledge, but to evaluate the effectiveness of the pedagogy. As a result, the students were very positive, helpful, and open to the process: they saw clearly that they would benefit from the information gained from the project.

### Recommendations to the College

From the results established here, it is possible to recommend the following:

- Students are very open to facilitating and actively engaging with projects whose aim it is to help them learn more effectively.
- Students are very keen to link mathematical models and physical reality, as they recognize its importance to structural engineering. This should be facilitated wherever possible across the programme.
- The use of MCQs in structural engineering requires further development and better design to enable quick assessment of conceptual understanding.

### Proposed Future Activities

From the analysis presented here it is clear that the MCQs need to be redesigned to better measure their intended outcome. In contrast (and perhaps in spite of the quantitative shortcomings), it was found that the pedagogical interventions were effective in enthusing the students and helping them better link mathematical models and physical reality. Clearly then, the interventions established for this Fellowship, ought to be maintained and extended where possible. This will include an evaluation of physical intuition at second year, and examination of introducing a problem-based learning element required physical intuition into first year.

### Further Reading

Brohn, D. (2005) *Understanding Structural Analysis*, 3rd edn. London: Paradigm Solutions.

Brohn, D.M. and Cowan, J. (1977) Teaching towards an Improved Understanding of Structural Behaviour, *The Structural Engineer*, 55 (1), 9–17.

Charlton, T.M. (1966) *Model Analysis of Plane Structures*. Oxford: Pergamon Press.

Dym, C.L. (1997) *Structural Modelling and Analysis*. Cambridge: Cambridge University Press.

Hilson, B. (1993) *Basic Structural Behaviour – Understanding Structures from Models*. London: Thomas Telford.

Ibell, T. (2010) Learning Structural Engineering, *The Structural Engineer*, 88 (8), 17–19.

Ji, T. and Bell, A. (2008) *Seeing and Touching Structural Concepts*. Abingdon: Taylor & Francis.

MacLeod, I.A. (2005) *Modern Structural Analysis*. London: Thomas Telford.

May, I.M. and Johnson, D. (2008) *The Teaching of Structural Analysis – A Report to the Ove Arup Foundation*. London: Ove Arup Foundation. Available from <http://www.theovearupfoundation.com/news/46.html>.

Owens, G. (2010) Structural Engineering Education in the 21st Century: The Way Forward. *The Structural Engineer*, 88 (1), 15.

Pippard, A.J.S. (1946) *The Experimental Study of Structures*. London: Edward Arnold & Co.

## BASICS: Building a System to Ingrain Core Competencies within Students

David Dorran,  
School of Electrical Engineering Systems

Contact: [David.Dorran@dit.ie](mailto:David.Dorran@dit.ie)

### Abstract

The aim of the project is to develop a system which will promote a solid knowledge of programmes' "core competencies" amongst students. This will be achieved by building a set of online quizzes which students will undertake on a regular basis throughout the delivery of programme modules. Quizzes will include feedback with links to web-based activities/information to help students develop their understanding.

**Keywords:** core competences, online quizzes, feedback

### Introduction

Educators preparing for the delivery of a module/subject do so with the assumption that the students undertaking the module have developed certain competencies beforehand. With this in mind, programmes/courses of study are generally designed so that the competencies required in one module are either developed in previous modules or, particularly in the case of introductory modules, are prerequisites for entry to a programme. This programme design methodology should ensure that students are well prepared for modules they undertake from Semester 2 of their first year until they complete their programme of study, typically 3–4 years later. However, the reality is quite different for a multitude of reasons, such as:

- Exams are often structured in such a way as to allow sections of modules to be omitted, i.e. a student can pass a module without knowing the entire content of the module
- A certain amount of surface learning can occur with the result that knowledge is quickly lost after initial assessment

If the expected level of understanding of a module's prerequisite competencies does not already exist, students can quickly become inundated with "new" concepts leading to cognitive overload and a reduction in the student's ability to digest module concepts effectively. In addition, if the educator recognizes the lack of prerequisite competencies within the students, as would be desired, the delivery of the module would have to be altered to deal with the issues that arise, thereby further increasing the educator's workload.

It is clear that students who are comfortable with the prerequisite competencies will have an easier route to meeting the learning outcomes of the programme, with the added benefit that the educator's task will be more straightforward.

The above discussion leads to a desire to provide a support mechanism which will encourage students to develop module prerequisite competencies. One way to achieve this is to ensure that all the assessment of all modules was such that students must know the entire content of each module at a sufficiently deep level in order to progress. This suggestion, while appealing in certain ways, would require significant changes to established module assessment structures and, perhaps more importantly, is likely to be overly excessive since certain module content may not form the prerequisite competencies for any future modules. Another possible approach is for each module coordinator to identify a set of prerequisite competencies for their module and assess these competencies at the start of module delivery, thereby refreshing students' understanding of the competencies before commencement of the module. This approach is highly focused but may result

in certain competencies being overly assessed for the case where the same competencies form prerequisites for a number of modules. Acknowledging this likely possibility leads to an alternative programme level approach to deal with the issue more effectively in which programme “core competencies’ are first identified in order to make best use of resources.

By initially focusing on the identification of a programme’s “core competencies” (defined here as prerequisite module competencies which occur in a number of programme modules) a wider range of modules will benefit from any support mechanism developed to promote the understanding of these competencies. In addition, these competencies could be continually reinforced throughout the programme so that assessments would not be specifically required at the commencement of any particular module. This approach was adopted in an Honours Degree Electric/Electronic Engineering undergraduate programme in Dublin Institute of Technology.

The remainder of this paper outlines the logistics associated with implementing a system to promote students’ understanding of programme core competencies; justification for the use of unsupervised online quizzes as the means to engage students; and findings resulting from an evaluation of the approach

## Outline of Project

### *System Development Considerations*

When considering the development of a system to promote students’ understanding of core competencies at a programme level, in addition to applying sound learning theory, both the perspectives of the students and faculty staff must be considered. In particular, the rationale for the quizzes should be made clear to students, and staff, who may feel resentful, with some justification, of the work and scheduling involved with additional assessments. This point is highlighted as students may feel they are being overly assessed on a particular topic. In order for the system to be embraced by both parties it should be reasonably time flexible and require a minimum effort to coordinate. These considerations resulted in the following desirable features in the system:

- The system should be flexible enough to be implemented a number of times over the duration of a semester.
- Feedback should be prompt, i.e. students should quickly know if they have grasped the core competency.

Such features can be readily accommodated using online quizzes. The next section outlines issues associated with the use of unsupervised online quizzes.

### *Use of Unsupervised Online Quizzes*

Online quizzes have been utilised in a broad range of disciplines to support student learning (Johnson, 2006; Kibble, 2007; Peat and Franklin, 2003). In Johnson (2006) it is noted that, amongst educational psychology students, higher use of optional online quizzes correlated with better academic performance, while an analysis of a survey of first year biology students found that 90% of students found weekly online quizzes to be either useful or very useful (Peat and Franklin, 2003). Online quizzes offer many benefits over their paper-based counterparts (EdTech); some key ones are listed below:

- Easy/wide access
- Facility to provide quick feedback
- Easy reuse of quizzes
- Allow multiple attempts
- Automatic corrections

The use of unsupervised online quizzes was explored in Kibble (2007) as means to provide formative assessment in a medical psychology programme. The paper explored the impact of offering “course credit” to students as an incentive to utilise the quizzes. In the first instance no credit was offered and it was observed that there was a high correlation between optional participation and higher end of semester summative assessment grades. Subsequently credit between 0.5% and 2% was offered as an incentive; Kibble (2007) notes that while the participation increased as a result there was evidence of widespread inappropriate use of the unsupervised quizzes.

From this review of the literature online quizzes appear to be very useful to both students and lecturing staff. The use of unsupervised quizzes is appealing due to the flexibility they offer to students and the low-cost of their implementation after initial setup. The difficulties with inappropriate use of such quizzes is acknowledged with the result that particular focus will be placed on quizzes which require a basic process to be applied; one in which it would be easier for a student to simply learn the process rather than copy from a colleague. It was also felt that the quizzes should generally contain a number of variables which could easily be randomised to allow for a large amount of variability in each question’s answer; although the process to determine the answer would be the same, or similar, in each case to promote sharing of knowledge between students. With this in mind multiple-choice style questions would be avoided except where a large amount of variability could be maintained.

#### *Implementation: Student Perspective*

Having identified unsupervised online quizzes as being a potentially effective means to support students’ understanding of core competencies at a programme level, the next step was to implement the system. This section outlines how the quizzes were implemented from a student’s perspective.

Students were required to complete six quizzes over a 13 week semester. The quizzes were frontloaded so that all the quizzes were completed by the end of Week 7; this was done so that students would gain benefit from completing the quizzes at an early stage. Quizzes were available for a period of one week, with students being allowed an unlimited number of attempts; all quizzes were unsupervised. The quizzes comprised of mainly calculation based questions, for reasons outlined above, related to four areas associated with electrical/electronic engineering, i.e. Electrical Systems, Electronic Systems, Mathematics, Programming. It was expected that students would be able to achieve a grade of 80% or more within 30 minutes.

Three faculty staff agreed to use the results of the quizzes as part of the continuous assessment component of their module; this meant that the results of two quizzes would be used in each of the three modules. As an incentive to students the results of the quizzes would contribute to 5% of the continuous assessment component of each module; it was agreed that the full 5% would be awarded to students who achieved an average of 80% in the quizzes and 0% otherwise.

#### **Methodology and Key Findings**

Students’ experience of the online “core competency” quizzes were evaluated via three focus groups which were facilitated by three members of the Institute’s staff separately; each facilitator had prior experience in facilitating such discussions. Two of the focus groups were recorded (audio only) and each focus group involved six students. The facilitators were provided with a set of questions by the system coordinator in advance of the focus groups to act as a guide for the discussion. The questions are available for download from <http://eleceng.dit.ie/dorran/basics>.

On completion of the focus groups the facilitator met with the system coordinator to discuss main findings. For the case in which the focus groups were recorded, the two facilitators and the

coordinator were present at the meeting and the coordinator noted the main findings. Following this the coordinator analysed the recordings and used this data together with the meeting's findings to generate a report which was reviewed and agreed upon by the facilitators. The report is available for download at <http://eleceng.dit.ie/dorran/basics>. The report was also distributed to all students for comment via email. One response was received which stated "I have read through the document and found it be exactly how we all feel about the core assessments".

For the case in which students were not recorded, a brief meeting between the facilitator and coordinator took place in which the main advantages and disadvantages were discussed. The facilitator then wrote a report on his key findings; the report is available for download at <http://eleceng.dit.ie/dorran/basics>.

The key findings from the reports are similar and are summarised below:

1. Students' attitude towards the quizzes were largely positive, and the purpose and rationale for their introduction was understood. It should be noted that the feeling towards the quizzes when they were first proposed was generally negative and somewhat resentful in some cases.
2. Students felt the quizzes were beneficial as they help motivate revision.
3. They felt that quizzes which related more strongly to material they were currently studying would also be useful.
4. Quizzes were time consuming – up to two hours in some cases – the coordinator had an expectation that each quiz would require 20–30 minutes.
5. 5% of CA mark was enough to motivate them; as did the 80% pass mark.
6. A certain amount of copying occurred (approx 10% of questions completed without any real understanding – mainly multiple choice).
7. Students felt they benefitted from having multiple attempts and being able to work together.

### Lessons Learned

This work investigates a method to support students' understanding of "core competencies" within an engineering programme. From an analysis of system requirements unsupervised online quizzes were identified as being suitable for further investigation.

A set of quizzes were developed and students' experiences of utilising these quizzes in an unsupervised environment were explored. In general students found the unsupervised core competency quizzes to be of benefit to their studies, although it is acknowledged that it is possible to complete the quizzes without any significant learning taking place. It is felt that the use of unsupervised quizzes are most appropriate to support the development of "short time-frame analytical skills" which are reinforced effectively through repetition. In mathematics an example of such a skill is the division of complex numbers; in electrical engineering one example is determining the equivalent resistance of resistors in series and parallel.

## Acknowledgements

The authors are grateful for the participation of the students and programme committee in undertaking this study. In addition, Gavin Duffy and Muireann O’Keefe are kindly thanked for their involvement in facilitating the focus groups.

## References

Kibble, J. (2007) Use of Unsupervised Online Quizzes as Formative Assessment in a Medical Physiology Course: Effects of Incentives on Student Participation and Performance. *Advances in Physiological Education*, 31, 253–260.

Johnson, G.M. (2006) Optional Online Quizzes: College Student Use and Relationship to Achievement. *Canadian Journal of Learning and Technology*, 32 (1), Winter. Available at <http://www.cjlt.ca/index.php/cjlt/article/view/61/58>. Accessed 28 December 2011.

Peat, M. and Franklin, S. (2003) Has Student Learning been Improved by the Use of Online and Offline Formative Assessment Opportunities? *Australian Journal of Educational Technology*, 19 (1), 87–99.

EdTech. Online quizzing. Effective use of online course tools. Available at <http://www.edtech.vt.edu/edtech/id/ocs/quizzes.html>. Accessed 24 January 2011.

## GeoLearn – Multi-Media Resources

**Audrey Martin,  
School of Spatial Planning**

Contact: [audrey.martin@dit.ie](mailto:audrey.martin@dit.ie)

### Abstract

This paper examines the potential of pedagogically designed video demonstrations in supporting the learning requirements of students in the Spatial Information Sciences (DSIS). Currently, over three hundred full and part-time students in the College of Engineering and Built Environment undertake a module in Land Surveying each semester and although these students range in discipline and academic level (NQAI 6–8), they all share a need for basic information and instruction in the area of practical land-surveying techniques. To accommodate this highly practical subject area, 50% of contact time is normally dedicated to group-based field exercises, the results of which are formally assessed. To enhance the students' practical learning experience in Land Surveying modules and provide a mobile (m)learning resource a number of short videos with voice-over instruction have been developed. These YouTube clips, of approximately three minutes in duration each, show the correct use of automatic levels and digital theodolites and can be directly accessed in the field via a web and video enabled mobile platform. This study highlights the effectiveness of designing high quality mlearning resource material for use in a wide range of disciplines by undergraduate students during their basic Land Surveying modules. Furthermore, it evaluates the effectiveness this student-centric approach to practical learning in terms of learners' potential for mlearning, learner motivation and also perceptions of understanding and retention with regard to course content for both full-time students and professional learners. Outcomes of the study indicate that the use of videos hosted on YouTube is very positive as it presents few barriers to learners in terms of access and usability.

**Keywords:** YouTube, mLearning, surveying

### Introduction

This study aims to investigate the potential of fine-grained instructional video clips to engage adult learners across a number of courses in active learning. Similar to a study carried out by Choi and Johnson (2005) the learning (comprehension and retention) and motivation of a sample of learners were examined by comparing learners' perceptions of video-based instruction with traditional class-based instruction. This study differs significantly from previous studies in that the sample size was large (n=93). Furthermore, as a number of independent courses constituted the population these were assessed both collectively and independently. Of additional interest to this study was the fact that a number of different tutors were engaged with varying cohorts, thus the ability of video-based instruction in standardising messages and thereby increasing the fidelity of implementing instruction as proposed by Dusenbury, Hansen and Giles (2003) was informally assessed. To achieve the aim of this study four research questions were identified:

1. Evaluate learners' potential for mlearning.
2. Measure learners' motivation.
3. Evaluates learners' perceptions of understanding and retention with regard to course content.
4. Assess student engagement with the mlearning resource.

### Outline of Project

#### *Collaborative Design Process*

Development of the most appropriate mlearning video materials was based on analysis of the module content of seventeen modules listed in Table 5.1. There are currently five independent module authors delivering Land Surveying modules. Additional demonstration support is provided

for fieldwork activities which constitute 50% of contact time across the gamut of disciplines within the College (Table 5.1). Thus, whilst the content in each module was similar, localised differences reflected particular student cohorts' academic requirements. Independent consultation with each module author resulted in the establishment of a number of learning and teaching criteria. Subsequently, module coordinators collaboratively agreed on two fundamental survey operations – levelling and theodolite work – as the most appropriate learning material. See Below for a list of Land Surveying Modules in DIT.

School	Course/Yr	Module	ECTS*	NQAI**	Student	Semester	Contact Hours			
							Lecture	Practical	Tutorial	Total
<sup>1</sup> SSPL	DT112/1	SSPL1001	5	8	FT <sup>†</sup>	S1	2	3	1	6
	DT112/1	SSPL1012	10	8	FT	S2	2	3	1	6
<sup>2</sup> CONS	DT117/1	CONS1008	5	6	FT	S1	2	2	0	4
	DT133/1	CONS1008	5	6	PT <sup>††</sup>	S1	2	2	0	4
	DT117/1	CONS1009	5	6	FT	S2	2	2	0	4
	DT133/1	CONS1009	5	6	PT	S2	2	2	0	4
	DT117/2	CONS2009	10	6	FT	S1/S2	2	2	0	4
	DT133/3	CONS2009	10	6	PT	S1/S2	2	2	0	4
	DT149/2	CONS2022	5	6	PT	S1	2	2	0	4
	DT149/3	CONS3025	5	6	PT	S2	2	1	0	3
<sup>3</sup> DSA	DT105/2	FT102/SP/2	1.5	7	FT	S1/S2	1	1	0	2
<sup>4</sup> CBS	DT004/2	SURV2020	5	7	FT	S1	2	2	0	4
	DT032/2	CIVIL2601	5	7	PT	S1	2	2	0	4
	DT024/2	CBEH2108	5	8	FT	S1	2	2	0	4
	DT004/2	SURV2021	5	7	FT	S2	2	2	0	4
	DT032/2	CIVIL2602	5	7	PT	S2	2	2	0	4
	DT024/2	CBEH2109	5	8	FT	S2	2	2	0	4

<sup>1</sup>SSPL = School of Spatial Planning, <sup>2</sup>CONS = School of Construction;

<sup>3</sup>DSA = Dublin School of Architecture; <sup>4</sup>CBS = School of Civil and Building Services

\*ECTS European Credit Transfer System; \*\*NQAI National Qualification Authority Ireland

<sup>†</sup>FT = Full-time, <sup>††</sup>PT = Part-time

**Table 5.1: Land Surveying Modules in DIT**

### Video Production

The approach taken during the design stage of the instructional video clips is briefly summarised here. The seven-step approach adopted is illustrated in Table 5.1, it includes the four core processes of micro-level instructional design (processes 4–7) as outlined by Snelson and Alison-Bowers (2009). The skills required for video production are not commonly part of an academics' background and in the case of this video development considerable technical support was provided by Roy Moore at the DIT's Telematics Facility. Previous research carried out by McGovern, Martin and Moore (2008) clearly outlined the creative, technical and logistical issues that arise when designing online video material for eLearning; these are not discussed here.



	Process	Description
1	Module content analysis	Evaluation of seventeen module descriptors from four Schools: Spatial Planning, Construction, Architecture, Civil and Building Services.
2	Module author consultation	Consultation with module authors with regard to student cohort characteristics, learning objectives and module outcomes.
3†	Core Skills identification	Mapping of instructional demonstrations to achieve educational objectives within a primary learning domain (cognitive, affective, psychomotor).
4†	Chunk information	Design of instructional content in small chunks to demonstrate specific tasks which can stand-alone or be combined to illustrate complex skills.
5	Apply relevant learning theory	Application of cognitive theory of multimedia learning (Clarke, 2008) and constructivist theory (Jonassen, Peck and Wilson, 1999).
6‡	Manage the technology	Production of ten video clips of 3-5 minute duration, from storyboard to final cut which was then uploaded to a dedicated YouTube channel.
7	Evaluate the product	Module coordinators informal evaluation undertaken and used to modify the video clips before going live to students.

† Collaborative processes ‡ Technical support in video production provided by Roy Moore at the DIT's Telematics Facility.

**Table 5.2: Instructional video clip design**

In total ten short video clips were completed; a student demonstrator was used in each clip and a voice-over provided instructional information. All videos were filmed on location in the Kings Inns Park where DIT students carry out field exercises, thus ensuring familiarity with the surroundings. The film quality was very high to ensure clarity when viewing the content in-house on larger screens. Individual video clips were designed to demonstrate very specific tasks which, when combined, show more complex tasks. Each clip lasts no longer than five minutes; this is to maintain interest and to allow for ease of review of the specific tasks. The "Levelling Demonstrations and Theodolite Demonstrations" videos were uploaded to YouTube to enable students to view them directly on site when required. Information and www addresses about the videos can be found on page p57.

#### **Levelling Demonstrations**

- i. How to set up a survey tripod
- ii. How to set up an automatic level
- iii. How to level the pond bubble in an automatic level
- iv. How to remove parallax in a survey telescope
- v. How to read a levelling "E" type staff

#### **Theodolite Demonstrations**

- i. How to centre over a point
- ii. How to roughly level a theodolite over a point
- iii. How to finely level a theodolite over a point
- iv. How to carry out the Plate Level Adjustment on a theodolite
- v. How to measure a horizontal angle using a theodolite

#### **Evaluation**

Evaluation of the fellowship project focused on the four research objectives outlined and reported here:

##### **1. Evaluation of learners' potential for mLearning**

A phone usage questionnaire was administered to assess learners' mobile learning potential, i.e. the technical capabilities of their current mobile devices and their willingness to engage with the digital

materials. Participants in the study (n=93) included both full-time students (n=55) and professional learners (n=38) from the four Schools mentioned in Table 5.1. Of the 93, only one learner was found not to own a mobile phone, 62% of learners' phones were under one-year old and 23% were less than two-years old with the remainder greater than three-years old. A slightly higher prevalence of older phones was found in the professional learner population but was not found to be significant. As both learner groups were found to own relatively new mobiles, issues related to poor quality data streaming and slow internet access was not perceived to be problematic for the study.

Current learner mobile internet habits were also analysed and it was found that 72% had used their phones to access the internet with 41% having previously accessed YouTube. The lower percentage of learners using the internet on their phones to stream live video material via YouTube was explained by the significant cost of mobile charges which can be incurred using this medium. Therefore to prevent the learning platform becoming an obstacle to the learning process, permissions to download the videos for viewing offline were given.

## *2. Measure learners motivation*

An assessment of the impact of multi-media material on learners' motivation (i.e. attention relevance, satisfaction and confidence) for the different learner groups in a practical environment was evaluated using open questions ranked in a four-point Likert type scale (Likert, 1932). All student cohorts had experienced traditional text-based instruction within their respective modules before the video-based demonstration; therefore a post-test only instrument was administered to evaluate perceptions of understanding, attention, relevance and satisfaction with the online instructional information. The study found that 78% of all learners preferred video materials to traditional class notes with 71% finding that video provided more detailed information than traditional class materials and 66% of learners stated that they paid more attention to the video material than traditional class notes. No significant difference was found in the results between professional learners and full-time students.

Over 90% of all learners found the material to be directly relevant to their module, with no difference between the learner groups. This was an expected outcome as the collaborative design process ensured very high consistency of materials with all module descriptors and learning outcomes. Learners' confidence in their abilities to emulate the skills demonstrated in the videos and incorporate them into real-world situations was very high and measured at 89%. As before no significant difference in results was found to exist between full-time students and professional learners.

Qualitative feedback on student satisfaction with the video materials indicated that learners were very comfortable with video as an instructional tool and found the medium easy to use and very beneficial when used together with traditional forms of teaching. It was found to be a good revision tool and more useful than traditional notes in real-world situations. There were no negative comments on the use of video as a support tool for teaching and learning and students have subsequently requested additional mlearning resources in video format.

## *3. Evaluate learners' perceptions of understanding and retention with regard to course content*

Assessment of the advantage of embedding video in the course material in terms of understanding and retention with regard to course contents was analysed using a pre- and post-test instrument. Factual recognition was evaluated using eleven closed questions ranked in a four-point Likert type scale. Results from the questionnaire showed an average increase in understanding of 24% in the basic survey methodologies presented across all learner cohorts irrespective of NQAI level or discipline.

Evaluation of the learning skills specifically enhanced by the video materials was evidenced through formal assessment of learners during their practical field sessions whereby the authenticity of assessment ensured a link between academic knowledge and “real-world” application required. A test cohort (Geomatics – DT112/1) undertook an open-book practical assessment in Module SSPL1012 whereby access to the video material was available on-site. Practical assessment of this nature is of particular benefit to the Geomatics cohort as their sixth semester is spent on placement with a survey company where knowledge of practical survey skills is considered a prerequisite. Students were not graded on this assessment but had a requirement to meet the learning outcomes as specified in the module descriptor; i.e. they had to be able to successfully undertake a horizontal angular survey and return a set of reduced calculations. Of the 28 students assessed only one student failed this exercise on the first attempt.

#### 4. *Assess student engagement with the mlearning resource*

On completion of the semester an assessment of the effectiveness and appeal of mlearning, its ease of use and the pattern of mlearning resource use during the semester was undertaken. The effectiveness of YouTube videos in a mobile environment was evaluated using closed questions ranked in a four-point Likert type scale for a population of 76 students. It was found that 82% of students found the use of the videos either very effective or effective in correctly applying their knowledge to practical scenarios which on repeated viewing helped reinforce their learning. Some 84% of learners felt that it was advantageous to view the videos in advance of field classes where the equipment would be used. The videos were accessed by 34% of learners as a revision tool from their home environment whilst 16% of learners used the videos to recap on the skills required while undertaking work on-site.

### **Future Research and Recommendations**

Findings of the study indicate that learners are very receptive to mlearning and increasingly expect it as a resource. Students have the personal resources to access the materials in a mobile platform and are willing to engage with well-designed mlearning material. In addition, such mlearning resources provide a very useful bank of standardised material on which tutors can depend to support their class-based teaching and practical demonstrations.

The proposed future work is to increase the bank of mlearning resources within the discipline of Geomatics and Surveying, incorporating the lessons learned from this project. The positive student engagement and their specific requests for additional resources will inform the materials developed into the future. The instructional video clip design process as outlined in this study could be used as a template for other designers when considering mlearning resources. However, it should be noted that production of high quality video is a slow process very much dependent on interdisciplinary support. Therefore a recommendation from this work is to establish an interdisciplinary mlearning team with the specific disciplinary knowledge and digital media acumen necessary to develop mlearning resources which have a broad spectrum audience.

### **Acknowledgements**

The author would like to acknowledge the technical support afforded her by Roy Moore in Telematics and also the pedagogical and financial support from the Learning Teaching and Technology Centre in DIT.

## References

- Choi, H.J. and Johnson, S.D. (2005) The Effect of Context-Based Video Instruction on Learning and Motivation in Online Courses. *The American Journal of Distance Education*, 215–227.
- Clark, C.R. (2008) *Building Expertise: Cognitive Methods for Training and Performance Improvement*, 3rd edn. San Francisco: John Wiley & Sons.
- Dusenbury, L.A., Hansen W.B. and Giles, S.M. (2003) Teacher Training in Norm Setting Approaches to Drug Education: A Pilot Study Comparing Standard and Video-Enhanced Methods. *Journal of Drug Education*, 33 (3) 325–336.
- Jonassen, D.H., Peck, K.L. and Wilson, B.G. (1999) *Learning with Technology: A Constructivist Perspective*. Upper Saddle River, NJ: Prentice Hall.
- Likert, R. (1932) A Technique for the Measurement of Attitudes. *Archives of Psychology*, 140: 1–55.
- McGovern, E., Martin, A. and Moore, R. (2008) The Production of High Quality Video for eLearning. Interactive Presentation in WG VI/2 – E-Learning,. *XXI Congress of the International Society for Photogrammetry and Remote Sensing*, Beijing, China.
- Snelson, C. and Elison-Bowers, P. (2009) Using YouTube Videos to Engage the Affective Domain in E-Learning. *Research, Reflections, and Innovations in Integrating ICT in Education*, 1481–1485.

## College of Business

## TechKnow-Share “A Social Learning Framework for Group Projects”

Mary Lawlor,  
School of Marketing

Contact: [Mary.Lawlor@dit.ie](mailto:Mary.Lawlor@dit.ie)

### Abstract

Many marketing students at undergraduate level are exposed to experiential learning in Years 3 and 4 where, through more varied pedagogies such as case studies and industry projects, they have a taste of real world marketing practice. It is often a challenge to engage students at second year where the theory and concepts of marketing are required to be taught, often employing a traditional passive learning paradigm (lecture based). The need to foster engagement early in a student’s learning is ever greater with a generation of students that want to construct knowledge socially and leverage Web 2.0 tools in their learning, within and beyond the classroom. The imperative to collaborate with their peers and other groups in the marketing community requires the student to develop competencies in leveraging Web 2.0 tools to enhance their experience in group projects and improve the quality of the work. The TechKnow-Share project addressed these realities with a group of second year undergraduate students that participated in the Google Online Marketing Challenge. This project also involved linkages with the Dublin Institute of Technology Hothouse companies with whom the students worked. Students were required to use a wiki for collaborative writing and webinars for asynchronous communication between students, lecturer and companies.

**Keywords:** experiential learning, meta skills, technical skills, group work, Web 2.0, wiki, webinars

### Introduction

The TechKnow-Share project was undertaken as part of a digital marketing module. The module runs over the course of one semester in a second year marketing undergraduate course and has 100% formative group assessment. The overall purpose of the project was to engage students in the practice of marketing early in their course through experiential learning using Web 2.0 tools. The project involved four partners: Google, Dublin Institute of Technology (DIT) Hothouse Companies, the Lecturer and Student groups. Google sponsor an Online Marketing Challenge by giving student teams credit to run three-week Adword search marketing campaigns for SMEs that have not yet used search marketing. The project was designed in such a way that students were required to develop their knowledge and use of Google Adwords. This enabled them to provide online advertising consultancy to DIT Hothouse companies. Students gained real experience working with a client company, received immediate feedback from their campaign and used a wiki and webinar to improve the team effort. The project process was highly structured through agreed timelines and project deliverables.

### Outline of Project

The project objectives were to:

- evaluate the Google online marketing challenge as an experiential learning project for developing industry specific technical skills
- assess the use of Web 2.0 technologies, such as wikis and webinars in improving the efficiency and effectiveness of the project
- develop a process to improve the management and outcomes of student groups.

#### *TechKnow-Share Initiative*

The Techknow-Share initiative set out to incorporate a real life learning experience for students in participating in the Google online marketing challenge. Marketing education literature informed the

design of the learning pedagogy for the project, providing conceptual frameworks for experiential learning and skills development for marketing students. The students were given training in group work and Web 2.0 tools through a webinar. They participated in two webinars to acquire the knowledge of Web 2.0 tools and update the lecturer on their progress. They learned collaborative writing skills through use of a wiki.

### *Experiential Learning*

Much of the marketing education literature points to experiential learning where students can acquire real world meta and technical skills in applied projects (Cronin 2009, Lavin 2010, Young 2010). Granitz and Koernig (2011) suggest that knowledge is socially constructed through conversations and actions with others. They further point out that Web 2.0 tools (wikis and webinars) advance experiential learning, enabling students to collaborate and learn beyond the classroom, often speeding up the production of knowledge. Considering the above meta skills classification of oral and written communication and team work, the challenge for the TechKnow-Share initiative was how to integrate meta and technical skill development in a group assessment.

Schibrowsky, Peltier and Boyt (2002) emphasise the need to blend conceptual knowledge (principles and critical thinking) with the skills required for work. Schlee and Harich (2010) use the following classification for skills:

- *Meta skills*
  - Oral communication
  - Written communication
  - Team work
- *Technical skills*
  - Software (Internet Marketing Analytics)
  - Web 2.0 (wikis and webinars)

Literature also emphasises that meta and technical skills are required, not just for entry level jobs but also for middle and upper level marketing jobs. Team work (meta skill) is considered by many authors as being crucial in the completion of complex tasks (Halfhill and Nielsen, 2007; Johnson, Johnson and Smith, 1998; Steen, 1998). Vance (2007) ranks team work skills as one of the most important attributes in graduate recruitment. This is evidenced in Chapman et al. (2010) by how Business schools have increased the number of group experiences students have in preparing them for today's group-oriented work place where they have to have developed an ability to work efficiently and effectively with others in a group. The TechKnow-Share project set out to develop these group skills in the context of experiential learning.

### *Meta skills*

Students working in groups can find the process and group dynamics complex, and often students do not have a positive learning experience (Chapman et al., 2010; Freeman and Greenacre, 2011). Students are often required to "hit the ground running" often with minimal training in group dynamics and group management techniques. This can result in intra-group conflict, lack of engagement, frustration with "free riders", (Freeman and Greenacre, 2011) and a less than optimal project submission. Katzenbach (1997) outlines the 4 Cs of effective teamwork; communication, collaboration, co-operation and compromise. To develop these skills, Prichard, Bizo and Stratford (2006) found that "prior team-skills training produced superior collaborative group work compared with that of students merely placed in un-facilitated groups".

Chapman et al. (2010) conclude from research that while groups are effective for learning, their experience can be improved by requiring groups to submit a timeline outlining the completion date for all tasks. They suggest a structured approach to group projects where the lecturer is involved not just in assessing student groups but also in managing and training groups. The TechKnow-Share

project specified that students would use agendas, minutes of meetings and reflections which were all part of a marking scheme.

### Technical Skills

The second type of skills development relevant to the TechKnow-Share project was technical skills. The increasing importance of technical skills has been documented in academic studies (Sodhi and Son, 2008; Young, 2010). Marketing positions often require that applicants possess very specialised industry skills. This, according to Schlee and Harich (2010), requires that students are competent in the use of marketing technology. Industry specific software and Web 2.0 technologies (Young, 2010), can facilitate experiential learning, improve the student overall experience (Cronin 2009) and satisfy practitioners' expectations for graduates to be technologically capable (Granitz and Koernig, 2011). The TechKnow-Share project equipped the students with skills in using Google Adwords.

### Pre TechKnow-Share Research

Prior to the commencement of the TechKnow-Share project, student experience of group work in a first semester project was analysed from reflective journals submitted by the 20 participating students. Katzenbach's (1997) framework was used to categorise their reflections into co-operation, collaboration, compromise and communication. This analysis of the students' experience of group work was consistent with the literature and directed the project's attempt to provide students with Web 2.0 tools for collaborative writing, communication and managing work within the TechKnow-Share project.

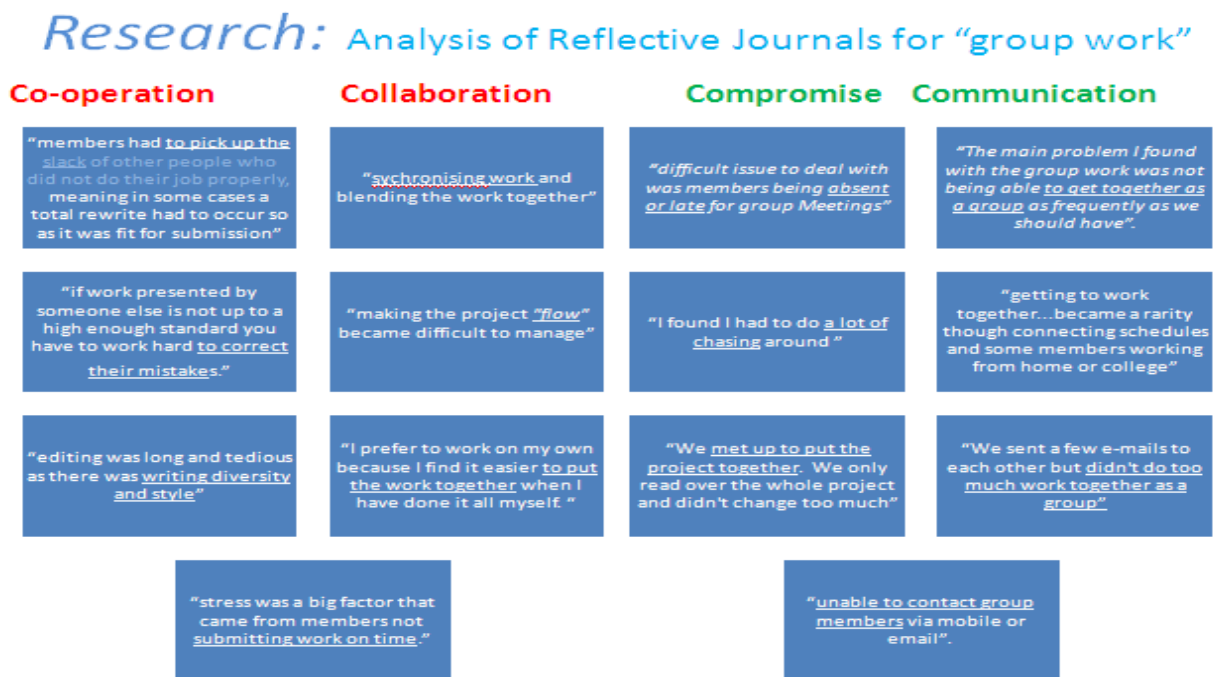

Figure 6.1: Analysis of Reflective Journals for "Group Work"



## Outline of Project

The semester long project with Google and DIT Hothouse, provided students with a dynamic learning opportunity requiring interaction with the lecturer, other students in their group and the practitioners. The Google online marketing challenge involved five student groups. Each team was given \$200 credit to manage a three week web based marketing campaign using Google's industry software Adwords. The progress of Google challenge was tracked and managed by the lecturer, using face-to-face interactions and Web 2.0 tools (Wikis and Webinars)

### *Industry Software (Google Adwords)*

The DIT twelve month Hothouse incubation programme is designed to provide entrepreneurs with business ideas, the expertise, networks and tools they need to develop highly successful global businesses. For the TechKnow-Share project, five high potential companies in the incubation stage, trading internationally were selected to participate. This link with Hothouse was considered very useful for the companies and the experiential learning component for the students and also consistent with DIT's aim of career focused learning. The selected companies had projected employment potential of ten employees in three years and a projected turnover of 1m. None of the companies had used Google Adwords prior to this project which was a requirement of Google.

The lecturer recruited the five businesses and facilitated an introductory meeting for the students and client business and a briefing for both parties. Clients were briefed by the lecturer as to the commitment involved and the expected benefits. They then met the student groups and were informed about the need for students to have access to certain company information and the company's technical/webmaster. The clients were advised that the student would act as a consultant to the client and the relationship would be between the student and the client.

In the pre-campaign strategy, students were required to give an overview of the client's business and a proposed online advertising strategy, with relevant keywords, advertising copy and the metrics used. Online tutorials on using Google Adwords and hands on computer lab work with the lecturer as facilitator provided the main structure for students learning the Adwords software. The client companies received a report from students on the conclusion of the TechKnow-Share project.

The post-campaign strategy detailed the actual campaign results, charts and recommendations for the clients. The report also required the group to reflect on the learning objectives, group and client dynamics. Students were required to continuously adjust the campaign in real time based on the decisions the group had taken and the resulting activity on the client's website. Google's 30 variable algorithm tracked the students' online activity and all changes made to the campaign. Students were assessed on their reports by Google and their lecturer.

### *Web 2.0 Skills*

*Webinars:* Two formal webinars were conducted as part of the project. Use of the webinars meant that students were able to enter the live classroom from different geographic locations. The first session began with students becoming familiarised with Wimba Live classroom, for example, use of voice board, chat and voice. In the first webinar *Learning how to use a wiki for Collaborative Writing*, students were introduced to the concepts of teamwork and collaborative writing through the use of wikis through participation. A second webinar *Progress report on Google Adwords online Marketing Challenge* was conducted after the formal classes ended and the project was still ongoing. Here, they discussed the progress of their project with the lecturer and their peers. They were graded for their participation in the webinar. Each of the two webinars was archived for students to access for reference at a later stage.

*Wikis:* Students prepared the template for their pre- and post-campaign strategies on the wiki. They were also required to use the wiki to write the reports collaboratively providing feedback on group progress through a webinar. The added feature of having the wiki documents asynchronously accessible from any location at any time contributed to the effectiveness and efficiency of the group work. The lecturer monitored the page creations and edits by each group member.

### *Management of Groups*

The role of the lecturer in this project was to act as a facilitator with the aim of improving the management and outcomes of student teams through planned co-operative activities. A process was designed to clarify the role and tasks for the lecturer, the student groups and the client companies. At the start of the project, the students were briefed on the need to appoint a team leader, plan meetings, document agendas and meetings, with a timeline to indicate the beginning and end date for all tasks. These roles and responsibilities are outlined in the following table.

<b>Lecturer</b>	<b>Student Group Dynamics</b>	<b>Client Dynamics</b>
Role: <i>Facilitator</i>	Role: <i>Leader/team member</i>	Level of client involvement
Recruit business	Meetings	Importance of Adwords to the client
Match group with client	Agendas	Access to client information
Company briefing	Minutes	Access to clients' technical specialist
Student briefing	Timeline	Student–client meetings
		Face-to-face, webinars
<i>Manage process: Group monitoring, feedback, grading</i>	Team evaluation	Student–client relationship
		Impact on clients' business

**Table 6.1: TechKnow-Share project definition of roles and tasks**

### **Project Outcomes**

Through their group based experiences as part of the Google online marketing challenge, it was felt that students developed a range of meta skills. In addition, technical skills were developed through learning how to use both Industry software and Web 2.0 technologies. These are summarised below:

<b>Meta skills</b>		
<i>Team skills</i>	<i>Written skills</i>	<i>Communication skills</i>
Co-operation	Write advertising copy	Student–student communication
Collaboration	Pre-campaign report	Student–client communication
Handling conflict	Post-campaign report	Student acts in a Consultancy role
Compromise	<b>Reflective</b> diary on learning	
Teamwork evaluation form	expectations and outcomes	

<b>Technical skills</b>		
<i>Google Adwords</i>	<i>Web 2.0 skills (wikis)</i>	<i>Web 2.0 skills (webinar)</i>
Target audience settings	Collaborative editing	Wimba Class room
Keywords	Collaborative writing	Webinar talk & text communication
Impressions, click through rates	Post comments	
PPC, CPM. Conversion rates	Hyperlinking	Interaction management
Website optimisation metrics		Accessing archived presentations
Monitor web analytics		

**Table 6.2: List of meta and technical skills developed through TechKnow-Share project**

## Evaluation

### *The Students' Perspective*

The feedback from students participating in the webinars was positive and reinforced its effectiveness and potential as a collaborative tool. Students found the technology user friendly and enjoyable to use. It was seen as a good way of communicating between groups, lecturer and clients based in different geographical locations.

Clickers were used to obtain feedback from students on the use of the wiki. Overall, students felt that the wiki enabled team members to collaborate, and improve communications with each other. In some cases, students felt that the wiki helped reduce conflict in the group as it assisted in members meeting deadlines, and work by each author could be viewed on an ongoing basis.

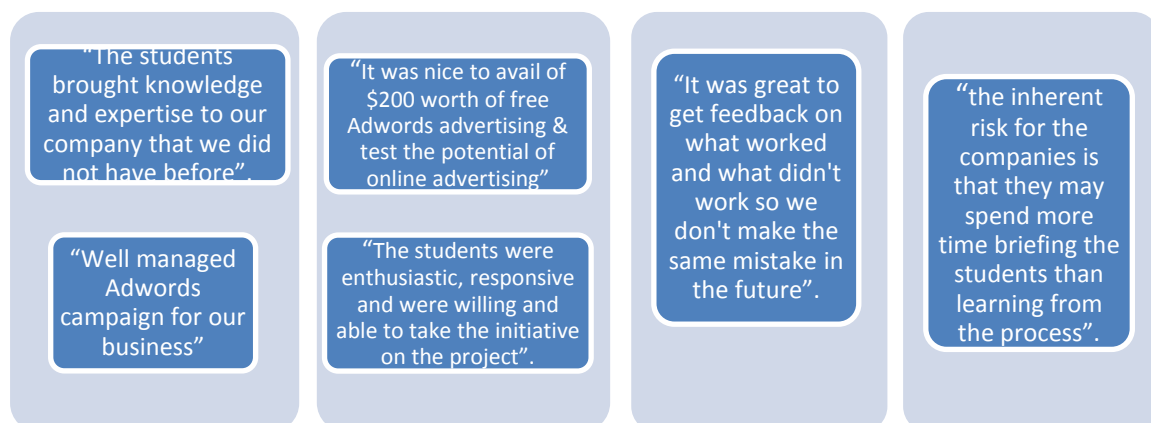

**Figure 6.2: Student feedback comments on the TechKnow-Share project**

Some students agreed that the wiki also encouraged members to take responsibility for specific tasks and enabled the work to be divided more evenly, resulting in greater transparency. Despite some groups not using the wiki to its full potential, the overall feedback suggested that it did help to improve the workings of the groups.

### *The Clients' Perspective*

After the completion of the TechKnow-Share project, the client companies were asked to provide feedback on how the Google online marketing challenge affected their business.



**Figure 6.3: Client feedback comments on the TechKnow-Share project**

The general feedback from the client companies was positive. A number of general issues emerged. The standard of consulting depended on the quality of the student groups, their relationship with the client company, their ability to deliver results from the advertising campaign and reports on their activity on schedule. This varied across groups, with some groups exceeding their clients' and their own expectations and another group falling short on promises. One company felt that the investment of their time in the student briefing was greater than the benefit of the students' contribution. Generally, companies felt that the management of the campaign by the students was professional and the student–client dynamic positive. The final feedback from Hothouse was that it was successful and an interest was expressed in participating in the TeckKnow-Share project again.

### Recommendations

A key recommendation from this TechKnow-Share project is the need for continued linkages between student projects in marketing and commercial activity within and outside Dublin Institute of Technology. There is potential for significant synergy between student and industry collaboration.

There is great potential in the design of student projects to give students the multiple learning opportunities to be technologically capable on graduation, to a business environment with increased expectation of graduates.

### Proposed Future Work

The TechKnow-Share project will continue in the academic year 2011–2012. Based on the findings of the student and client company research more support for the client companies in the form of online Adwords tutorials will be made available in advance of the project.

### Acknowledgements

I would like to thank everybody at the DIT Learning, Teaching and Technology Centre, who provided me with invaluable advice and support throughout the project.

### References

- Chapman, K.J. Meauter, K.L., Toy, D. and Wright, L.K. (2010) Are Student Groups Dysfunctional? Perspectives from Both Sides of the Classroom. *Journal of Marketing Education*, 32 (1), 39–49.
- Cronin, J.J. (2009) Upgrading to Web 2.0 An Experiential Project to Build a Marketing Wiki. *Journal of Marketing Education*, 31 (1), 66–75.
- Freeman, L. and Greenacre, L. (2011) An Examination of Socially Destructive Behaviors in Group Work. *Journal of Marketing Education*, 33 (1), 5–17.
- Granitz, N. and Koernig, S.K. (2011) Web 2.0 and Marketing Education: Explanations and Experiential Applications. *Journal of Marketing education*, 33 (1), 57–72.
- Halfhill, T.R. and Nielsen, T.M. (2007). Quantifying the “Softer Side” of Management Education: An Example Using Team Competencies. *Journal of Management Education*, 31, 64–80.
- Johnson, D., Johnson, R. and Smith, K. (1998) Cooperative Learning Returns to College: What Evidence Is There that it Works? *Change*, 30 (4), 26–35.
- Katzenbach, J.R. (1997) The Myth of Top Management Teams. *Harvard Business Review*, 75 (6), 82–92.
- Lavin, M. (2010) The Google Online Marketing Challenge. *ABD Journal*, 2.
- Prichard, J.S., Bizo, L.A. and Stratford, R.J. (2006) The Educational Impact of Team-skills Training:

Preparing Students to Work in Groups. *British Journal of Educational Psychology*, 76, 119–140.

Schibrowsky, J.A., Peltier, J.W. and Boyt, T.E. (2002) A Professional School Approach to Marketing Education. *Journal of Marketing Education*, 24, 45–55.

Schlee, R.P. and Harich, K.R. (2010) Knowledge and Skills Requirements for Marketing Jobs in the 21st Century. *Journal of Marketing Education*, 32 (3), 341–353.

Sodhi, M.S. and Son, B.G. (2008) ASP, the Art and Science of Practice: Skills Employers Want from Operations Research Graduates. *Interfaces*, 38, 140–146.

Steen, M. (1998) Managers Seek to Balance Individual Rewards with Group Goals. *Infoworld*, 20 (37), 91–92.

Vance, E. (2007) College Graduates Lack Key Skills. *Chronicle of Higher Education*, 53 (22), A30.

Young, M.R. (2010) Transforming the Initial Marketing Education Experience: An Action Learning Approach. *Journal of Marketing Education*, 32 (1), 13–24.

## College of Sciences and Health

# Improving the Undergraduate Laboratory Learning Experience through Redesigned Teaching and Assessment Strategies, Integrating Transferable Skills and Focusing on Feedback

**Julie Dunne and Barry Ryan,  
School of Food Science and Environmental Health**

Contacts: [Julie.Dunne@dit.ie](mailto:Julie.Dunne@dit.ie) and [Barry.Ryan@dit.ie](mailto:Barry.Ryan@dit.ie)

## Abstract

This project aimed to improve the laboratory learning experience for undergraduate science students, focusing initially on first and third year cohorts, through specific objectives. Firstly, to incorporate novel teaching and assessment methods, including student led laboratories, in-house produced instructional videos, “Clickers” audience response devices, and pre-practical on-line multiple choice questionnaires (MCQ) assessments. Secondly, to develop timely feedback mechanisms, including peer review, tutor face-to-face and audio feedback, online automatic feedback, and report checklists. Finally, to imbed transferable skills into the laboratory including group work, communication skills (written and oral), organisation and project planning, health and safety, and preparedness for laboratories, final year projects and placement.

Pedagogical evaluation was through anonymous MCQ and independent academic facilitated discussion forums. The main benefits were students who are better prepared, both for basic undergraduate laboratories and for independent research-based final year projects; continuity in the development of transferable skills; improved assessment quality through constructive alignment and appropriate feedback; and improved student satisfaction through engagement and feedback. The key recommendations arising from this study are: to encourage preparedness for practical sessions; harnessing technology to engage students through interesting pre-practical activities; to encourage an improved culture of feedback, including mechanisms such as podcasts, which also “feed-forward”; and to encourage a culture where value is added to modules by actively incorporating transferable skills into all student activities and assessments, rather than a “bolt on” approach.

**Key Words:** assessment, transferable skills, feedback, laboratories

## Introduction

Traditional or *expository* laboratory teaching methods, where students follow a given procedure to obtain a pre-determined outcome will allow students to manipulate equipment, learn standard techniques, collect and interpret data, and communicate the finding in a written report (Bennett and O’Neale, 1998). However recently there has been debate on the merits of these methods. The level of critical thinking required for performing the experiment, and the consequent deep learning achieved is low, and there is no opportunity for creativity or contextualisation (McDonnell, O’Connor and Seery, 2007). Furthermore, the environment required for co-operative learning, which requires students learning together with peer tutoring, towards a common goal, is not facilitated by traditional laboratories (Eilks et al., 2009).

A more ideal approach integrates application of knowledge to solve problems, group work, and an opportunity to design experiments, including consideration of the safety aspects (Bennett, Seery and Sovegjartho-Wigbers, 2009). The group work element is particularly important not only in relation to the socio-constructivist perspective on learning, but also because group work probably comes closer than any other single activity in preparing students for employment, and has been highlighted by the IBEC Education and Skills survey (McGann, 2010) as a skill which needs to be developed further in third level graduates.

## Outline of the Project

With regards to the first year cohort, a redesigned assessment strategy was implemented for a basic lab skills module to specifically target the problem areas of scientific observation and report writing over the course of an academic year. To support this approach the module content, both lecture and laboratory, was redesigned to better align to each other and also to help the student to “construct” their own learning. This redesign placed a higher emphasis on continual assessment of lab preparedness, improved the students report writing skills through a reduced number of reports accompanied by formative, constructive feedback and focused on the correct laboratory technique within the laboratory environment.

To prepare the students for their laboratory sessions each student was given the complete laboratory manual at the start of each semester. The manual linked to additional resources, including lab instructional videos which were produced in-house, and available through *Webcourses*, the Institute’s virtual learning environment (VLE). The students were also required to complete short, graded multiple choice quizzes targeting the important theory behind the upcoming laboratory. The MCQ was automatically graded and provided instant feedback to the student on each question.

To support the development of their communication skills, the students initially reported individually on short distinct sections of a typical scientific report and received one-to-one feedback. Following on from this, students worked in small groups to produce four group reports over the course of a 12 week semester. Each report was graded by the lecturer and one-to-group feedback was given. The students also anonymously peer assessed (APA) each other’s contribution to the group report. Upon completion of the APA process, the lecturer facilitated a discussion which was used to suggest improvements for future reports. To align learning outcomes and the assessment of lab skills the students’ practical, problem solving and report writing skills were assessed by an end of year laboratory-based exam which incorporated both technical and communication components.

The third year component of this joint project involved the re-structuring of Food Chemistry laboratory practicals associated with two related modules, with the aim of adding to the learning outcomes of traditional laboratory teaching methods through redesigning learning activities, implementing appropriate and timely feedback processes, and integrating transferable skills including group work and presentation skills. In the first module students worked in groups to “run” the practical for the rest of the class. The method was provided to the group, who then researched the necessary theory to provide the pre-practical presentation. The group was responsible for liaising with the technician to requisition the necessary chemicals and equipment for the experiment. They were also accountable for the safety aspects. On the day, they were in charge of organising the lab, and explaining the theory, the method, and afterwards, the calculations. The process was repeated in the second module; however the group was also required to devise its own experiment, and its members were guided through suitable literature to aid this process. In both modules, anonymous peer marking of group members was a component of the assessment.

Group laboratory report submissions were a feature of these modules. Weekly face-to-face feedback sessions allowed representatives from each group to peer review and discuss the written reports of all groups, and to get expert feedback from the teacher. A generic scripted summary of this feedback was recorded by the teacher using *Audacity* software, and the audio podcasts made available to listen directly or download from the Institute’s VLE. This was used in preparation of a final individual lab report. The assessment also included a group scientific poster group. A two-hour feedback session incorporating peer and teacher feedback on draft posters was organised ahead of final submissions.



## Aims and Objectives

The aim of this joint project was to maximise the learning associated with undergraduate laboratories for first and third year students by redesigning and aligning assessment and teaching strategies, devising and implementing appropriate and timely feedback processes, and integrating transferable skills at key stages in the curriculum. The student groups were selected based on their participation in suitable modules lectured at Dublin Institute of Technology, School of Food Science and Environmental Health. The first year cohort consisted of students taking the following modules: Laboratory Techniques and Computer Applications, DIT Module Code: TFCH1007 and Foundation Organic Chemistry, DIT Module Code: TFCH1003. The third year group comprised of students taking Food Chemistry I and II, DIT Module Code: TFCH3011/12

The aim of this project would be achieved through the following objectives:

<b>Objective One: Incorporation of Transferable Skills</b>	
<b>First Year</b>	<b>Third Year</b>
laboratory preparation (video & MCQ) scientific observation technical manipulation scientific reporting/writing laboratory safety	team work communication project planning preparedness for final year project employment preparation

<b>Objective Two: Redesigning Assessment Practices</b>	
<b>First Year</b>	<b>Third Year</b>
pre-practical on-line assessment	student led laboratory practicals

<b>Objective Three: Focus on Feedback</b>	
<b>First Year</b>	<b>Third Year</b>
peer feedback tutor feedback on-line, instantaneous feedback	peer feedback tutor feedback audio feedback

## Summary of Main Findings

### First Year Group

#### *Laboratory Preparation*

The main purpose of the on-line multiple choice quizzes was to prepare the students for the upcoming laboratory session. The students participated fully with the on-line quizzes (100% completed at least 8 out of the 10 quizzes). The vast majority of the students, 94% and 91% respectively, felt the quizzes were user friendly and gave them enough time to complete. Of those surveyed 77% felt better prepared for the upcoming laboratory after completing the quiz, noting that they felt more familiar with the lab (equipment, concepts, aims, etc.) after completing the MCQ and that this helped remove anxiety from coming into the lab.

Student opinion from the evaluation forum gave further insight into the possible reason behind why almost one quarter of students, after engaging with the lab manual and quiz, did not feel better prepared for the lab. The main problem evidenced was scientific calculation – the general student consensus being “*We feel like we were thrown in at the deep end*”.

Students felt motivated to read the manual before going into the lab: *“Sometimes when you read it [the lab manual], it’s just words on a page, but when it’s in a question you have to think about it”*. Indeed, if there was no MCQ associated with the lab manual the students *“would have just skimmed over the lab manual”* as with other lab based modules. The reduced number of reports per semester was also popular with students; one student noted that *“it sounds like we are lazy, but its actually not!”* and that fewer reports mean that *“the lecturers have more time to go through [the lab report] with you”*. Students also engaged more with the in-house produced laboratory videos than with the lab manual as a method of preparation for the upcoming lab session (76% compared to 53%).

### *Skills Development*

The student responses were very clear that the content of the module, and the skills they learnt, were appropriate to their course. For example, 91% of those surveyed could see the relevance of the techniques they learnt in this module to other modules in their course. Furthermore, 96% and 92% respectively felt more confident in the application of the skills learnt and collection data during a typical lab. Here the critical technical skills are highlighted (e.g. instrument calibration and usage), in conjunction with transferable skills such as data recording and observation.

The aligned nature of the module (lectures aligned to labs and subsequently the real world connection) was observed by 83% of the students. Students commented that *“the lab work helped me to understand the lectures and visa versa”* and *“I could see the application of some of the labs in the real world”*. Students were comfortable working individually or in groups, although initially group work was resisted by the students; *“We did not know what to do, we had never worked in groups this size before ... we were out of our comfort zone”*. Students appreciated the importance of group work, noting that *“We will be working in groups after college, so it’s important we learn how to deal with it now”*.

### *Report Writing*

In the module redesign the number of reports was reduced from twelve to four per semester. Overall the module scores improved modestly (5% for Semester one and 9% for Semester two) compared to the year previous to the module redesign. Students observed the benefit of peer involvement (86% perceived benefit of working with peers) which almost matched the confidence of the student in producing a good quality scientific report (79%). Students noted the lecturer facilitated feedback session as important: *“I learnt what I had to do to improve my section of report from discussing reports written by my groupmates”*.

### *Feedback*

Invariably the students were encouraged by receiving feedback. The vast majority of students (91% and 90%) felt that the MCQ on-line feedback was helpful, and improved their understanding even if they got the answer wrong. Student comments included *“feedback was really helpful, it was the best part”*.

Almost all students (96%) felt that the lab report feedback was beneficial, with 98% of students commenting that one-to-one or small groups were the best way to give feedback. The students were motivated by the feedback and their perceived improvement in their report-writing skill: *“you see your marks rise every week ... you’re aiming for 10/10 in your last one [report]”*. Some 96% of students noted that they tried to implement the feedback points in subsequent reports and consequently 82% of students noted that their scores improved over the course of the year. Furthermore, the majority (84%) of students noted that their reports improved in other lab based modules also and 81% of students felt more engaged by the alternative assessment strategy and module redesign.

### Third Year Group

#### *Transferable Skills and Preparedness for Work Placement and Final Year Projects*

The reform aimed to improve the student experience by providing students with the opportunity of putting the literature into context, in a supported setting, thus applying their knowledge to design their own experiment. All students agreed that choosing their own experiment had made the literature more relevant and meaningful, while almost all (94%) considered that designing their own experiment motivated them to engage with the literature. Students realised that literature must be adapted for class experiments, which will be critical for students' preparedness for final year projects, where adapting the literature and experimental design will be the norm.

Overall, almost all students (94%) believed they were better prepared for final year projects, with one suggesting the experience was *"like a stepping stone towards final year projects"*. Furthermore, the majority of students believed that the project has increased their employability skills, including teamwork, organisation, communication and research. Interestingly, one student commented that *"we looked at running the lab like it was a job"* while another described how she *"talked about this module in my interview for work placement. It made me feel like more of a grown up person, not just a student."* Clearly, the students consider the experience to be more authentic and relevant to the workplace.

#### *Feedback*

Perhaps the most welcome aspect of these modules from the student perspective was the provision of varied, timely and relevant feedback. All students agreed that reflecting on their own reports, reading the reports of peers and discussing them with the lecturer at weekly feedback sessions was a useful way to learn. Particularly successful was the podcasted feedback. The students in this study mostly agreed (89%) that it was useful in preparing their final report with one commenting *"It's such a simple thing, but it's so effective. I still use it for different subjects"*. Together with the report checklist, which students also mostly believed (94%) to be useful for this module's written report, there appears to be a form of "feed-forward" or remediation feedback, which allows students' self-regulation, and to develop greater skills in self-evaluation. All students agreed that the feedback provided would help with the assessments and reports in other modules, with one stating that *"I have put the checklist on my wall. If you follow it, you can't forget anything."*

#### *Assessment*

Overall the students were satisfied with the assessment of the modules under review. The poster assessment was generally well received (78%) with students commenting that *"the poster made looking at someone else's group work more interesting than a set of ordinary lab reports"*. Students particularly welcomed the opportunity to re-submit the group poster following the poster session within two weeks. This is in line with best practice in assessment and feedback according to Nicol and Macfarlane-Dick (2006) and Black and Williams (1998), both suggesting that students should be able to engage in activities which help to close the gap between current and desired performance. Students felt *"looking at other's posters helped me to see where we went wrong, and what we did well and it was great that we got a chance to resubmit it"* and *"it was good that she [the lecturer] didn't just say 'yeah, you should have put that in', but instead said 'right, off you go and make the changes'"*.

#### *Room for Improvement: Feedback Sessions*

While many students (73%) did believe the whole group benefitted from a member attending a feedback session, there is room for improvement here. There was some breakdown with passing on the information from the session to the group as a whole, and this would need to be addressed in future, perhaps by students recording the minutes and emailing them to their group and the tutor.

Surprising, only about half the group (54%) thought that the project had improved their presentation skills, but on further examination, this was because they either felt they were already good at presenting, or because they had not actually been part of the presenting team. In future, the latter could be improved by suggesting that all students must present at least a small part of the presentation.

## Research Outcomes

Research outcomes from this project will be applicable Institute-wide to all practical based modules. In brief, the benefits to both the student and the academic are several fold and are summarised below along with key recommendations arising from the project evaluation.

### *Benefits*

1. Students who are better prepared; both for basic undergraduate laboratories and for independent research-based final year projects.
2. Continuity in the development of transferable skills resulting in increased employability.
3. Improved assessment quality through constructive alignment and appropriate feedback.
4. Improved student satisfaction through engagement and feedback.

### *Key Recommendations*

1. Encourage preparedness for practical sessions, harnessing technology to engage students through interesting pre-practical activities suited to level and stage.
2. Encourage an improved culture of feedback, including innovative feedback mechanisms such as podcasts, which also “feed forward”.
3. Encourage a culture where value is added to modules by actively incorporating transferable skills into student activities and assessments, rather than a “bolt on” approach.

## Future Work

The project currently focuses on first and third year students in individual modules; however it is self-sustaining as it can be rolled out across all years and all practically based modules without further resource requirements. It will be particularly effective if there is a critical mass of staff engaging. The fellowship team are available for discussion with all staff, and indeed have already been approached by staff interested in applying the model to their modules.

Further research funding to sustain this project will be sought through:

- National Digital Learning Resources (NDLR) which supports research into sharing of digital/online resources, which will be generated in this project through pre-practical videos and associated Respondus MCQ quizzes;
- National Academy for Integration of Research, Teaching and Learning (NAIRTL) Grants Initiative which supports integration of Research, Teaching and Learning.

This funding would allow the project to be further developed, and permit collaboration with others both in DIT and elsewhere. Going forward, collaboration within DIT is important in the overall rationalisation in DIT structures, and economy in provision of Science delivery.

## Acknowledgements

The project was supported by the LTTC in general and Fionnu Kelly specifically. Instructional videos were prepared in-house with the support of Roy Moore of the Telematics Facility, DIT.

## References

- Bennett, S.W. and O'Neale, K. (1998) Skills Development and Practical Work in Chemistry. *University Chemistry Education*, (2) 58–62.
- Bennett, S.W., Seery, M.K. and Sovegarto-Wigbers, D. (2009) Practical Work in Higher Level Chemistry Education. In I. Eilks and B. Byers (eds) *Innovative Methods in Teaching and Learning Chemistry in Higher Education*. London: Royal Society of Chemistry, pp. 85–102.
- Black, P. and William, D (1998) Assessment and Classroom Learning. *Assessment in Education*, 5 (1), 7–71.
- Eilks, I., Markic, S., Bäumer, M. and Schanze, S. (2009) Cooperative Learning and Peer-tutoring in Higher Level Chemistry. In I. Eilks and B. Byers (eds) *Innovative Methods in Teaching and Learning Chemistry in Higher Education*. London: Royal Society of Chemistry, pp. 103–122.
- Mc Donnell, C., O'Connor, C. and Seery, M.K. (2007) Developing Practical Chemistry Skills by Means of Student-driven Problem Based Learning Mini-projects. *Chemistry Education Research and Practice*, 8 (2), 130–139.
- McGann, K. (2010) IBEC Education and Skills Survey, IBEC, October 2010.
- Nicol, D. and Macfarlane-Dick, D. (2006) Formative Assessment and Self-regulated Learning: A Model and Seven Principles of Good Feedback Practice. *Studies in Higher Education*, 31 (2), 199–218.

## Pre-lecture Resources to Reduce In-lecture Cognitive Load

Michael Seery,

School of Chemical and Pharmaceutical Sciences

Contact: [michael.seery@dit.ie](mailto:michael.seery@dit.ie)

### Abstract

In order to reduce an observed gap in Year 1 performance between students who had and had not completed chemistry at Leaving Certificate in a first year chemistry group, an intervention based on cognitive load theory was implemented. Students completed ten pre-lecture resources before associated lectures. The resources took no longer than five minutes to complete and aimed to introduce students to the core terminology of the lecture. Resources were designed with the principles of cognitive load theory and multimedia resources in mind. They were administered through the DIT Webcourses virtual learning environment and students obtained feedback on a short quiz and a mark in the gradebook after completing each resource quiz. The resources were integrated into the lecture activity, increasing in-class discussion. After implementing the resources, the performance in a mid-semester exam and the end of year exam was examined. For the first time, students' prior knowledge was not a predictor of performance in these exams. The work resulted in dissemination at several national and international conferences, an accepted journal publication and a Teaching and Learning award.

**Key Words:** cognitive load, eLearning, first year experience, pre-lecture resources

### Introduction

Introductory chemistry for those without a background in the subject has a high cognitive load (Sirhan, Gray and Johnstone, 1999). New learners in chemistry are very quickly exposed to a large amount of new terminology which they need to understand and interrelate (Johnstone, 2009). As the chemistry syllabus builds progressively, learners need to continually call on recently acquired knowledge and integrate that into ever increasing layers and representations of the subject as they progressively develop their understanding and begin to relate these terms at representational, atomic and macro levels (Johnstone, Sleet and Vianna, 1994).

In this fast pace, it is easy for learners to slip. A lecture which builds on a previous lecture is all very well, but if learners did not have time to understand those concepts which are being built upon, they fall behind. This was observed in a previous study by the author. A longitudinal analysis over several years found that students who had prior knowledge of chemistry at Leaving Certificate level tended to do better in their Year 1 performance (semester and end of module exams) than those who had no prior knowledge (Seery, 2009). However, there was no association between Leaving Certificate chemistry and marks in later years. This led to the hypothesis that a consideration of the teaching of material in Year 1 in the context of cognitive load theory may be a suitable grounding for an intervention to assist these learners.

### Outline of the Project

Cognitive load theory is a model for instructional design based on an understanding of how we acquire, process and retain new information. It proposes that a successful use of the model will result in more effectual learning, and the retaining of information in the long term memory, which can be recalled when required in a given context. The theory distinguishes three types of cognitive load (Ayres and Paas, 2009; Sweller, 2008):

1. **Intrinsic load** is caused by the complexity of the material. This depends on the level of expertise of the learner – in other words it depends on the learner's understanding of the subject.

2. **Extraneous load** depends on the quality or nature of the instructional materials. Poor materials or those that require a large amount of working memory to process will increase the load and leave little capacity for learning.
3. **Germane load** is the mental effort required for learning. Because of the limited capacity of the working memory, germane load (the extent of learning) is dependent on the extent of the extraneous load, and also on the material and expertise of the learner – the intrinsic load. An expert on a topic is able to draw from prior knowledge, and release working memory capacity for germane load processing.

The consideration of cognitive load theory for the purposes of multimedia learning was summarised succinctly by Mayer. Mayer's model is shown in Figure 8. 1 below (Clarke and Mayer, 2008):

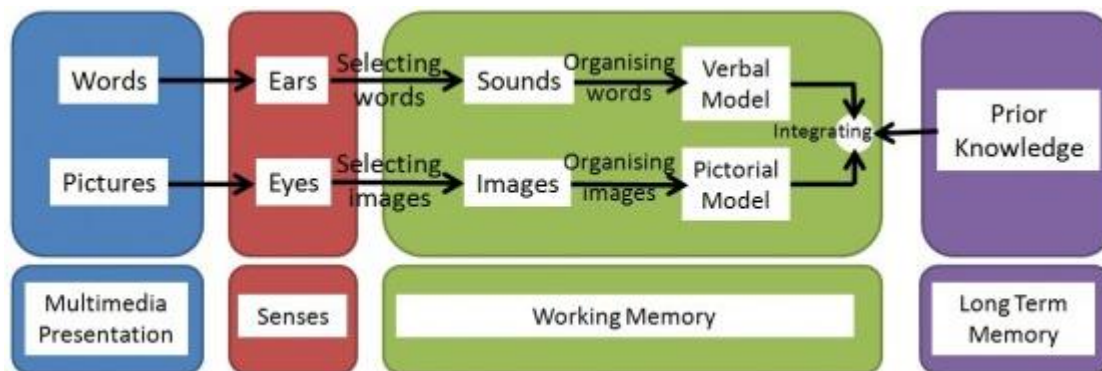

**Figure 8.1: Cognitive Theory and Multimedia Learning (Clarke and Mayer, 2008; Mayer, 2005)**

Information is presented to users in the form of words and pictures (there are other channels too, but these are the most pertinent to eLearning). The user senses these and the working memory processes some information at any time. If this material can be related to existing prior knowledge, it is integrated with it, and effective learning occurs – the new experiences and information are stored in the long-term memory.

### Project Implementation

This project aimed to reduce the cognitive load of novice learners in chemistry by providing online pre-lecture resources which they could interact with before coming to the lecture. Ten resources designed in the context of the principles of multimedia design were developed and integrated into the students' VLE, *webcourses.dit.ie*. In designing the resources, the core terminology that would arise in each lecture would be presented. For example, in a lecture that might involve 20 new terms, 6–7 were chosen as core, and incorporated into the pre-lecture resource. It was not the aim of the pre-lecture resource to cover all material in the lecture, rather to introduce the students to the core terms required to begin to approach these terms.

The resources were no longer than five minutes long and had a quiz at the end. The quiz provided an opportunity for students to check their understanding of the core concepts underlining each lecture, and students received both answer-specific feedback (to help address any misconceptions) along with a grade for their quiz in the Gradebook. The grade for all ten resources was worth 1.5% of the module mark. Students completed two quizzes per week for the first four weeks of Semester 1, with an additional two later in the semester.

In the lecture, the resources were purposefully integrated. At the very least, they were referred to, and built on in presenting new material in lectures. In some cases, students were asked in the pre-lecture resource to prepare some material for contribution to the lecture. In the latter case, some

useful discussion in the lecture replaced a teacher-centred approach. This approach will be used more in the future.

### Evaluation

A concern before rolling out these resources was that students would not use them. In fact, students were very keen to use them, with access rates typically over 85%. Problems initially were technical – for example library computers could not play the Flash formats in which the resources were produced. After the first week, the students settled quickly into a routine. Lectures were held on Mondays and Thursdays, and the most common day to access was Sunday afternoons and Wednesday evenings. 65% of students spent between 2 and 20 minutes on the resources. An analysis of semester test marks found that the large difference between students who had not completed chemistry and those who had – present for every one of the last six years of the module – had reduced to the extent that there was no significant difference between the groups. Similarly the gap between examination marks between the two groups disappeared completely. The literature on prior knowledge is full of examples of how prior knowledge is a sole predictor of future achievement (Dochy, Segers and Buehl, 1999), so these results are pleasantly surprising in this context.

### Discussion and Lessons Learned

The model described here technically does not change the lecture style. However, because students were arriving at the lecture with some familiarity with the lecture concepts, and often with pre-assigned activities, lectures could move to a more discussion based format. This has been found with other students involving pre-lecture resources (Collard, Girardot and Deutsch, 2002; Narloch, Garbin and Turnage, 2006).

It was considered important to purposefully integrate the pre-lecture resources into the lectures to attribute them a sense of value among students. This ranged from mentioning the resources right through the pre-assigned activity, to be developed in lectures. It was found in the latter case that the level of pre-preparation students had done was impressive, and allowed the lectures to integrate a high level of discussion in developing the content and ideas under consideration. Lectures in this case became very active learning environments, and the discussion element is considered to be a fundamental part of the enhancement of learning.

An output of the work that was not considered was that of the first year experience. Students in first year are in a new environment and unsure of their standing there, leading to uncertainty in their new environment (Yorke and Longden, 2004). Feedback from quizzes and discussions in lectures can provide students with a sense of their progress in the very early stages of Semester 1, before more formal aspects of continuous assessment take place.

It was a concern that “buy-in” from students would not take place. The level of usage and engagement was very high. This may be due to various factors, for example a (small) assessment component, the placing of value on the resources by the lecturer, and possibly the fact that new first years are more open to ideas of what happens at third level. An advantage of seizing this openness early on is that these kinds of activities can encourage students to develop a sense of agency in their own learning (Nicol, 2007; Nicol, 2009).

### Recommendations

As a result of the work from this project, the following recommendations can be made:

1. Lectures should use purposeful resources to support first year material, meaningfully integrated with lectures and other learning activities. The use of technology enhances the



reproducibility of these and after initial development, automates a lot of the work regarding recording of usage and marks.

2. Lecturers should be encouraged to develop in-class discussion, both peer–peer and peer–tutor. This can be facilitated by clickers.
3. Informal feedback early in the year is important to give students a sense of their standing in the new learning environment.

## Acknowledgements

The author would like to thank Dr Claire Mc Donnell who has done a lot of work to support this project and Dr Roisin Donnelly for her ongoing support and guidance.

## References

Ayres, P. and Paas, F. (2009) Interdisciplinary Perspectives Inspiring a New Generation of Cognitive Load Research. *Educational Psychology Review*, 21 (1), 1–9.

Clarke, R.C. and Mayer, R.E. (2008) *E-Learning and the Science of Instruction* (2nd edn). San Francisco: Pfeiffer (Wiley).

Collard, D.M., Girardot, S.P. and Deutsch, H.M. (2002) From the Textbook to the Lecture: Improving Prelecture Preparation in Organic Chemistry. *Journal of Chemical Education*, 79 (4), 520–523.

Dochy, F.J.R.C., Segers, M. and Buehl, M.M. (1999) The Relation between Assessment Practices and Outcomes of Studies: The Case of Research on Prior Knowledge. *Review of Educational Research*, 69, 145–186.

Johnstone, A.H. (2009) You Can't Get There from Here. *Journal of Chemical Education*, 87 (1), 22–29.

Johnstone, A.H., Sleet, R.J., and Vianna, J.F. (1994) An Information Processing Model of Learning: Its Application to an Undergrad Laboratory Course in Chemistry. *Studies in Higher Education*, 19 (1), 77–87.

Mayer, R.E. (2005) Cognitive Theory of Multimedia Learning. In R.E. Mayer (ed.) *Cambridge Handbook of Multimedia Learning*. Cambridge: Cambridge University Press, pp. 31–48.

Narloch, R., Garbin, C.P. and Turnage, K.D. (2006) Benefits of Prelecture Quizzes. *Teaching of Psychology*, 33 (2), 109–112.

Nicol, D. (2007) Laying a Foundation for Lifelong Learning: Case Studies of E-assessment in Large 1st-Year Classes. *British Journal of Educational Technology*, 38 (4), 668–678.

Nicol, D. (2009) Assessment for Learner Self-regulation: Enhancing Achievement in the First Year Using Learning Technologies. *Assessment and Evaluation in Higher Education*, 34 (3), 335–352.

Seery, M.K. (2009) The Role of Prior Knowledge in Undergraduate Performance in Chemistry – A Correlation-Prediction Study. *Chemistry Education Research and Practice*, 10, 227–232.

Sirhan, G., Gray, C., Johnstone, A. H. and Reid, N. (1999) Preparing the Mind of the Learner. *University Chemistry Education*, 3(2), 43–46.

Sweller, J. (2008) Human Cognitive Architecture. In J.M. Spector, M.D. Merrill, J. van Merriënboer and M.P. Driscoll (eds), *Handbook of Research on Educational Communications and Technology* (3rd edn). New York: Routledge, pp. 369–381.

Yorke, M. and Longden, B. (2004) *Retention and Student Success in Higher Education*. Maidenhead: Society for Research into Higher Education: Open University Press.

## Teaching Fellowship 2010–11 Dissemination Outputs, Papers, Presentations

### Noel Fitzpatrick, Bernadette Burns, Brian Fay: School of Art Design and Printing

- As part of the DIT Fellowship programme, an overview of the project was given in Aungier St on 23 September 2010. Updates of work in progress were also given through the LTTC website, at the Showcase on 12 January 2011 and as part of a College presentation on 23 February 2011. Recommendations based on the research work were provided at the DIT Management Forum on 10 May 2010 and as part of **NQAI Institutional Review** presentation on 30 March. In addition to the report included in this publication, a final summary of work was presented as a poster at the 11 January 2012 Showcase event.

### Adrian Davis: School of Hospitality Management and Tourism

- Presentation of interim findings to School of Hospitality Management and Tourism, January 2011.
- Participation in Association for the Study of Higher Education (ASHE) workshop, Queen's University Belfast, March 2011.
- Interim findings presented to workshop on student retention, School of Hospitality Management and Tourism, April 2011.
- Findings presented at the International Conference for Education, Research and Innovation (ICERI) November 2011.
- As part of the DIT Fellowship programme, an overview of the project was given in Aungier St on 23 September 2010. Updates of work in progress were also given through the LTTC website, at the Showcase on 12 January 2011 and as part of a College presentation on 23 February 2011. Recommendations based on the research work were provided at the DIT Management Forum on 10 May 2010 and as part of **NQAI Institutional Review** presentation on 30 March. In addition to the report included in this publication, a final summary of work was presented as a poster at the 11 January 2012 Showcase event.

### Mary Lawlor: School of Marketing

- As part of the DIT Fellowship programme, an overview of the project was given in Aungier St on 23 September 2010. Updates of work in progress were also given through the LTTC website, at the Showcase on 12 January 2011 and as part of a College presentation on 24 November 2011. Recommendations based on the research work were provided at the DIT Management Forum on 10 May 2010 and as part of **NQAI Institutional Review** presentation on 30 March. In addition to the report included in this publication, a final summary of work was presented as a poster at the 11 January 2012 Showcase event.

### Colin Caprani: School of Civil and Building Services Engineering

It is intended to continue this work, improving on the gains made in the project. In the coming months, the Fellow will:

- Participate in the Institution of Structural Engineers Annual Academics Conference on the teaching of structural behaviour;
- Present a paper at the LIN Conference to be held in October in DIT Bolton St.
- In the longer term, with further results established and the methodologies and effectiveness better quantified, it is intended to disseminate this work in the mainstream engineering education literature, for example: *The International Journal of Engineering Education*. In addition, publication of a summary paper in *The Structural Engineer*, for dissemination to practising and academic structural engineers who may not be reading the engineering education journals previously mentioned will be sought. With a worldwide readership, *The Structural Engineer* has played an important part in the development of the teaching of structural behaviour (see references on page 25).
- As part of the DIT Fellowship programme, an overview of the project was given in Aungier St on 23 September 2010. Updates of work in progress were also given through the LTTC website, at a

College presentation on 27 October and at the Showcase on 12 January 2011. Recommendations based on the research work were provided at the DIT Management Forum on 10 May 2010 and as part of **NQAI Institutional Review** presentation on 30 March. In addition to the report included in this publication, a final summary of work was presented as a poster at the 11 January 2012 Showcase event.

#### **David Dorran: School of Electrical Systems Engineering**

- This work has been published at the International Conference of Engineering Education, Belfast, 2011.
- As part of the DIT Fellowship programme, an overview of the project was given in Aungier St on 23 September 2010. Updates of work in progress were also given through the LTTC website, at a College presentation on 27 October and at the Showcase on 12 January 2011. Recommendations based on the research work were provided at the DIT Management Forum on 10 May 2010 and as part of **NQAI Institutional Review** presentation on 30 March. In addition to the report included in this publication, a final summary of work was presented as a poster at the 11 January 2012 Showcase event.

#### **Audrey Martin: School of Spatial Planning**

- Martin, A. (2011) Video Supports the Lecturing Star. International Federation of Surveyors (FIG) Working Week. 18–22 March 2011. Marrakesh, Morocco.
- Martin, A. (2011) Assessing the Effect of Constructively Designed YouTube Video Instruction on Student Engagement and Learning Outcomes. In progress. Ten online YouTube videos:

##### **Levelling Demonstrations**

- 1 How to set up a survey tripod  
<http://www.youtube.com/user/MartinBondzio#p/u/9/O3Dp1kjl8gY>
- 2 How to set up an automatic level  
<http://www.youtube.com/user/MartinBondzio#p/u/8/IIYAoNHPEao>
- 3 How to level the pond bubble in an automatic level  
<http://www.youtube.com/user/MartinBondzio#p/u/5/v8-xGcBYAats>
- 4 How to remove parallax in a survey telescope  
<http://www.youtube.com/user/MartinBondzio#p/u/7/AIBJLxQ3cE>
- 5 How to read a levelling "E" type staff  
<http://www.youtube.com/user/MartinBondzio#p/u/6/o8d-5S1z0e8>

##### **Theodolite Demonstrations**

- 6 How to centre over a point  
<http://www.youtube.com/watch?v=EKE3ZwYaMms>
  - 7 How to roughly level a theodolite over a point  
<http://www.youtube.com/watch?v=sA3ubs8vaug>
  - 8 How to finely level a theodolite over a point  
<http://www.youtube.com/watch?v=0hAOD4OQMGY>
  - 9 How to carry out the Plate Level Adjustment on a theodolite  
<http://www.youtube.com/watch?v=kvkXR-hKG04>
  - 10 How to measure a horizontal angle using a theodolite  
<http://www.youtube.com/watch?v=7aYsAwXlZkg>
- As part of the DIT Fellowship programme, an overview of the project was given in Aungier St on 23 September 2010. Updates of work in progress were also given through the LTTC website, at a College presentation on 27 October and at the Showcase on 12 January 2011. Recommendations based on the research work were provided at the DIT Management Forum on 10 May 2010 and as part of **NQAI Institutional Review** presentation on 30 March. In addition to the report included in this publication, a final summary of work was presented as a poster at the 11 January 2012 Showcase event.

### Julie Dunne and Barry Ryan: School of Food Science and Environmental Health

- *Putting the Student in Charge: Adding Value to the Food Chemistry Laboratory through Student Generated Experiments, Integration of Transferable Skills, and Peer and Audio Feedback*. Full paper and oral presentation, Edulearn, Barcelona, 4–6 July 2011.
- *Integrating Formative Feedback into Individual and Group Assessments in a First Year Organic Chemistry Module*. Full paper and oral presentation, Edulearn, Barcelona, 4–6 July 2011.
- *“Ask the Audience”: Clickers in the Classroom*. Oral Presentation, NAITRL, NUI Galway, 9–10 June 2011.
- *Listen. Re-listen. Podcasting for Feedback (and Feed-forward) of Undergraduate Laboratory Reports*. Poster presentation, Edtech, Waterford Institute of Technology, 1–2 June 2011.
- *Improving the Undergraduate Laboratory Learning Experience through On-line Pre-lab Resources, Assessment Redesign and Formative Feedback*. Poster presentation, Edtech, Waterford Institute of Technology, 1–2 June 2011.
- *Classroom Response Devices (“Clickers”): Interactive Quizzes for the Common Functional Groups of Organic Chemistry*. Poster Presentation, NDLR Fest, Trinity College Dublin, 23 March, 2011
- As part of the DIT Fellowship programme, an overview of the project was given in Aungier St on 23 September 2010. Updates of work in progress were also given through the LTTC website, at the Showcase on 12 January 2011 and as part of a College presentation on 30 March. Recommendations based on the research work were provided at the DIT Management Forum on 10 May 2010 and as part of **NQAI Institutional Review** presentation on 30 March. In addition to the report included in this publication, a final summary of work was presented as a poster *Formative Feedback Strategies to Improve Science Laboratory Learning. It’s Good to Talk!* at the 11 January 2012 Showcase event.

### Michael Seery: School of Chemistry and Pharmaceutical Sciences

- The work completed for the Fellowship caught the attention of several peers. As a result, two workshops for the Higher Education Academy (UK) were delivered in Scotland and London, along with several other talks. The following lists the outputs from the project:
- M. K. Seery, *Blending In-class Lectures and Online Resources – Three Strategies to Support Lectures, More Effective Lectures*, HE Academy, University of Edinburgh, December 2010 (invited lecture).
- M. K. Seery, *Pre-lecture Resources to Support First Year Lectures, 11th Annual Showcase of Learning and Teaching Innovations*, DIT, 12 Jan 2011 (lecture).
- M. K. Seery, *Supporting First Year Learners with Pre-lecture Activities, Easing the School-to-University Transition: Improving and Enhancing the Undergraduate Experience*, 30 March 2011, Queen’s University, Belfast (invited lecture).
- M. K. Seery, *Blending In-class Lectures and Online Resources – Three Strategies to Support Lectures, More Effective Lectures*, HE Academy, University College London, March 2011 (invited lecture).
- M. K. Seery and C. Mc Donnell, *Supporting Student Learning with Pre-lecture E-resources: Design, Implementation and Evaluation, EdTech 2011, Waterford Institute of Technology*, 1 June 2011 (lecture).
- M. K. Seery and C. Mc Donnell, *Pre-Lecture Resources to Reduce In-Lecture Cognitive Load*, Graduate Student Conference, Dublin Institute of Technology, 14 June 2011 (lecture).
- M. K. Seery, *Pre-Lecture Resources to Reduce In-Lecture Cognitive Load, Gordon Research Conference: Chemistry Education Research and Practice*, Charlotte, North Carolina, July 2011.

#### Publications

- M. K. Seery and R. Donnelly, *The Implementation of Pre-lecture Resources to Reduce In-class Cognitive Load: A Case Study for Higher Education Chemistry. British Journal of Educational Technology*, accepted, 2011. (impact factor = 1.255, ISI Journal Citation Reports Ranking: 2009: Education & Educational Research: 32 / 139)

- M. K. Seery, *Using Pre-lecture Resources in your Teaching*, Resource Pack available on DIT Learning Teaching and Technology Centre website ([www.lttc.dit.ie](http://www.lttc.dit.ie))
- As part of the DIT Fellowship programme, an overview of the project was given in Aungier St on 23 September 2010. Updates of work in progress were also given through the LTTC website, at the Showcase on 12 January 2011 and as part of a College presentation on 30 March. Recommendations based on the research work were provided at the DIT Management Forum on 10 May 2010 and as part of NQAI Institutional Review presentation on 30 March. In addition to the report included in this publication, a final summary of work was presented as a poster at the 11 January 2012 Showcase event.

*Award*

- *2011 Jennifer Burke Award for Innovation in Teaching and Learning*, Irish Learning Technology Association and Dublin City University (see [www.jenniferburke.ie](http://www.jenniferburke.ie)).

**Appendix A: EoL strategic fellowship projects 2010/11**

- drawing upon and contributing to the findings from the DIT's own data and national and international data and best practice as appropriate.  
 During 2010/11 it is expected that at least one Teaching Fellowship in each College would focus upon Assessment

	<b>First Year Curriculum</b>	<b>Assessment and Feedback</b>	<b>Student Engagement and Retention</b>	<b>Curriculum Development</b>
<b>Modularisation</b>	Projects in this cell would focus on curriculum reform – facilitated by our modular structure – to assist commencing students change their learning strategies to meet the expectations of HE.	Projects in this cell would consider the impact and potential of modularisation on assessment with particular attention to the pedagogical potential of formative assessment as a way to limit the overall summative assessment load and to provide feedback to students on their learning.	Projects in this cell would address the way in which the DIT modular structure could be used to redesign delivery of programmes and/or curriculum design in a way that would be responsive to those factors contributing to retention.	Projects in this cell would use the modular structure to design programmes and to use teaching and assessment methods that would encourage student participation and engagement in their learning.
<b>Diversity</b>	Projects in this cell would explore and compare different strategies to support learner engagement within the first year of undergraduate programmes.	Projects in this cell would focus upon the diversification of assessments and the use of “non-traditional” assessments as a way to provide effective feedback to students on their learning.	Projects in this cell would focus upon the use of strategies to include, engage and retain non-traditional students within existing programmes	Projects in this cell would develop creative ways to use the DIT modular structure to address the needs of non-traditional students.
<b>eLearning</b>	Projects in this cell would make use of online resources to encourage active learning and information literacy among first year students.	Projects in this cell would leverage technology to support innovative assessment practices and to provide timely and appropriate feedback to students.	Projects in this cell will aim to improve student retention through the use of eLearning technologies.	Projects in this cell would focus on the use of e-learning technologies to engage students and motivate them to more active learning.

**Appendix B**  
**Fellowship 2010/11 Evaluation Feedback**

- 1. How did you first become aware that the DIT was establishing Faculty Teaching Fellowships in each Faculty e.g. did you see them advertised, word of mouth etc.?**
- word of mouth: 5
  - by e-mail /advert: 1
  - both email/WoM: 2
- 2. How did you become a Teaching Fellow for your College e.g. were you nominated to apply, did you submit the application form when you saw the call etc? Please indicate how**
- Nominated: 1
  - Applied when saw call: 7
- 3. How did you feel this application process worked for you? How might it be improved if there is another call for College Teaching Fellowships next year?**
- Application process was fair, form did not require too much work.
  - Fine. It clashed a little with the very busy period at the end of the year, but otherwise fine.
  - I would have preferred to have submitted my own application rather than to pursue a research topic that was allocated to me.
  - Looking back at the form now it seems very clear, but when I filled it out last year some aspects had to be clarified for me and I needed assistance with the likes of sustaining the project field.
  - I think the 400 word max for project description is small, and would increase it and reduce other fields.
  - The application process worked well. I was well prepared in that I have a strong area of pedagogical research which I wanted to extend and this was the perfect vehicle for that.
  - The process was so complex/long that I nearly did not complete it.
  - Very good. An interview process might be good also, as the word count was limiting on the written application. Worked well for me
- 4a. How important was the money in you being able to undertake your fellowship research?**
- 3 Very important,
  - 4 quite important,
  - 1 not important but it helped,
  - 0 didn't make any difference,
  - 0 don't know
- 4b. What of the following best describes how you used your Fellowship money? (tick all that apply)**
- 4 Buy out of hours
  - 6 Buy equipment/resources for the project etc.
  - 0 Attend training courses/workshops etc.
  - 5 Disseminate findings at a conference etc.
  - 3 Other please specify
- I did use the monies to buy out some hours but retrospectively I would have bought more hours.
  - I would have carried out this work anyway, but dissemination of the work facilitated participation in several conferences, which in itself sustains the research and opens doors for new ideas.
  - It eased the effort I was required to make on many other aspects of my work, freeing me up to address the Fellowship properly.

**5a. A Teaching Fellowship launch, the DIT Showcase event, a series of four lunchtime College sessions and a slot in the management forum session have been organised as a way to support and promote your Fellowship work within the DIT. Have you attended these sessions?**

- Yes – 8
- No – 0
- All but one of the lunchtime sessions due to clash of events. And also a writers session (mid fellowship, and a writer's retreat!)
- All of the above, I sent a poster to the management forum.
- All of them.
- I attended two lunchtime sessions, the launch and the Showcase event.
- Launch, showcase, two lunchtime sessions, management forum.
- The Launch the Showcase One College Session.
- The launch, showcase and two of the lunchtime sessions.
- Two - can't remember.

**5b. How useful have these been to you and how might they be improved in any subsequent years?**

- I did not find the lunchtime sessions were well supported. I found the LTTC more support during fellowship than many of the other fellows. I suppose some engaged more with the process outside their own project than others. The showcase event was very good. The launch was also good, but I felt it was the last I saw of many Fellows. The report to the management forum was not helpful. I don't think there was much interest in the Fellowships, probably due to a very full agenda, but I think it is still important to promote the Fellowships and for sustainability.
- It would be more useful if non-Teaching Fellows attended to see what work was being carried out in their School.
- Really good to get feedback and engage with other Fellows.
- Showcase and lunchtime sessions were useful to see what others were doing, but didn't mind doing the management forum to help promote fellowships.
- The monthly sessions were very useful but I had difficulty in attending the other events due to work commitments. They were useful mainly because they were a point of focus; the fact that I was presenting my work to others made me focus more on what I was doing. It was also interesting to see what the other fellows were working on.
- They were very useful. I thoroughly enjoyed them. It was particularly interesting to see the work that those in other Colleges are undertaking.
- Very useful – however due to time restrictions I could not attend all College sessions. I found the launch particularly useful in getting some contact information for previous studies in this area.

**5c. Have seminars, workshops, presentations been organised in your dept as a way to also promote the work?**

- Yes – 3
- No – 5
- Based on my research I have been joint chair to a debate on student engagement and chaired a discussion on the interim findings.
- I've outlined my work to others in my department as I needed some help in evaluation.
- Small group discussion and short workshops. Self-organised.

**6. Support from the LTTC staff has been made available to help you plan/implement your Fellowship project write up your report. What kind of support have you found most useful so far and what kind of additional support would you like for the next stage of your work?**

- General discussions were most helpful, to frame research and make connections with others in the area.
- I found all staff in the LTTC to be extremely helpful and cooperative.



- I had great help with some focus groups from the LTTC and colleagues. Otherwise I didn't avail of any LTTC assistance, although it was good to know I could make use of it and feel it was ready if the need arose.
- I have been provided with any and every support required, throughout the Fellowship, and previously.
- I have not required any support.
- Mostly contact support from Miriam regarding other studies undertaken in my area with a link to DIT Perhaps mentor visits? Time-permitting.
- Support by means of guidance and to bounce ideas off always appreciated!

**7a. Has being a teaching fellow for your College been as you expected?**

- Yes : 6
- No: 2

*b if no, in what way*

It was a lot more work than expected!

**8. Any other comments you would like to make about the Fellowships?**

- Excellent scheme; if money dwindles, would suggest keeping it going, as Fellowship is a powerful brand. That said, it will always need some money to incentivise.
- I think it is a great brand, and it should be continued even if funding is reduced. It can be seen as a metric to demonstrate good practice in T&L, similar to awards, even if funding is reduced.
- I think the Fellowship is very worthwhile. I feel the majority of resources could be directed into allowances on the time table or buying out a significant number of hours and also providing funding to publish the work done.
- The main hindrance for me in engaging on this research area is the lack of time available to develop materials and evaluate their effectiveness.
- It's a great way to investigate approaches to teaching and learning and get some recognition and support while doing it. I hope that it continues as I've seen very positive outcomes from my own work and the work of others involved in the programme.
- The teaching fellowship has been a catalyst for further research opportunities which I was able to identify during my investigation. I now intend to investigate student engagement issues which I hope will make a contribution to educational research.
- Very rewarding and a great way to develop your teaching whilst interacting with like-minded people. A great way to share ideas.

## Appendix C

### School of Art, Design and Printing assessment feedback sheet

+

School of Art, Design & Printing *Head* John O Connor BDes MA ANCAD MIDI  
 Faculty of Applied Arts, Dublin Institute of Technology, Mountjoy Square, Dublin 1  
 t: 402-4138, f: 402-4297, e: artanddesign@dit.ie



#### Assessment form: Critical Theory *FT544/545/546*

name of student	>		>	year of study
project/module	>			
examiner	>	date		
		<i>research</i>	<i>analysis &amp; development</i>	<i>Evaluation/structure</i>
		<i>presentation/referencing</i>		
<i>70-100% first</i>		exceptional level of research and collation of sources with ambitious initiative	creative and intelligent analysis, exceptional development of concept and critical reflection	excellently structured argument underpinning an independent critical position
		exceptional level of presentation in text and visuals, correct implementation of referencing guidelines		
<i>60-69% 2.1</i>		comprehensive level of research and collation of sources with initiative	creative and intelligent analysis, high level of conceptual development, and strong critical reflection	coherently structured argument with clear attempt to develop a critically independent position
		coherent and appropriate presentation, mainly correct implementation of referencing guidelines		
<i>50-59 2.2</i>		competent research and collation of sources	competent analysis, evidence of creativity & conceptual development	competent structure with some evidence of critical evaluation
		competent presentation, satisfactory use of referencing		
<i>40-49% pass</i>		adequate research of standard accessible sources	adequate analysis, but essentially descriptive	some attempt to evaluate material and structure an argument
		adequate presentation, with some incorrect use of referencing		
<i>0-39% refer</i>		limited or unfocussed research	limited analysis	little or no attempt to structure an argument, unsupported opinion
		poor presentation, inadequate referencing		
		<i>value</i>	<i>value</i>	<i>value</i>
		>	>	>
		<i>weighting</i>	<i>weighting</i>	<i>weighting</i>
		>	>	>
		<i>mark</i>	<i>mark</i>	<i>mark</i>
		>	>	>
				<b>total</b>
				>
comment				
examiner's signature	>			date
				>