Doctoral

Science

2015

Atmospheric Cold Plasma as a Tool for Microbiological Control

Dana Ziuzina

Technological University Dublin, dana.ziuzina@tudublin.ie

Follow this and additional works at: <https://arrow.tudublin.ie/sciendoc>



Part of the [Food Science Commons](#)

Recommended Citation

Ziuzina, D. (2015) *Atmospheric Cold Plasma as a Tool for Microbiological Control* Doctoral thesis, DIT, 2015. doi.org/10.21427/z871-5m10

This Theses, Ph.D is brought to you for free and open access by the Science at ARROW@TU Dublin. It has been accepted for inclusion in Doctoral by an authorized administrator of ARROW@TU Dublin. For more information, please contact yvonne.desmond@tudublin.ie, arrow.admin@tudublin.ie, brian.widdis@tudublin.ie.



This work is licensed under a [Creative Commons Attribution-NonCommercial-Share Alike 3.0 License](#)

ATMOSPHERIC COLD PLASMA AS A TOOL FOR MICROBIOLOGICAL CONTROL



Dana Ziuzina BSc

School of Food Science and Environmental Health
Dublin Institute of Technology

A thesis submitted to Dublin Institute of Technology in
fulfilment of the requirements for the degree of

DOCTOR OF PHILOSOPHY

Supervisors:

Dr. Paula Bourke

Dr. PJ Cullen

June 2015

Abstract

Outbreaks of foodborne human illnesses resulting from contaminated raw or minimally processed fruits and vegetables have been widely reported globally. The microbiological challenges associated with fresh produce are diverse and respond differently to minimal processing technologies. Atmospheric cold plasma is a relatively new technology and represents a potential alternative to traditional methods for decontamination of foods. The objective of this work was to determine the influence of extrinsic atmospheric cold plasma (ACP) treatment control parameters and to optimize treatment parameters for decontamination with respect to different forms of key safety challenges pertinent to fresh produce.

The optimisation studies demonstrated that inactivation efficacy of treatment, when tested against high populations of *E. coli* suspended in liquid media, was governed by the processing parameter of mode of exposure, treatment time, post treatment storage time, voltage levels, working gas and media composition. Post treatment storage time emerged as a critical treatment parameter for consistency and efficiency of bacterial inactivation with the system. The effect of media complexity was evident with higher inactivation rates achieved in media with simpler composition. Antimicrobial efficacy of ACP increased when voltage level and gas mixture with higher oxygen content was utilised, nullifying the effect of mode of ACP exposure and media composition.

High voltage in-package indirect ACP treatment with 24 h of post treatment storage time, selected as the more favourable treatment approach in terms of

produce quality retention, was highly effective for decontamination of cherry tomatoes and strawberries inoculated with *Salmonella*, *E. coli* and *L. monocytogenes* monocultures and against background microflora of produce. However, the produce type and the contaminating pathogen influenced decontaminating effect of ACP with higher inactivation rates achieved for Gram-negative bacteria and bacteria associated with smooth surface of produce.

The antimicrobial potential of high voltage either direct or indirect in-package atmospheric air ACP treatment with subsequent 24 h of storage was proven to be effective for inactivation of pathogens in the form of monoculture biofilms commonly implicated in foodborne and healthcare associated human infections, *E. coli*, *L. monocytogenes*, *S. aureus*, *P. aeruginosa* established during 48 h on abiotic surface. However, the efficiency of ACP treatment was again bacterial type dependant. Although complete inactivation of metabolic activity of Gram-negative bacteria could not be achieved, electron microscopy analyses confirmed the destructive action of ACP treatment.

In-package high voltage indirect ACP treatment was effective against *Salmonella*, *L. monocytogenes* and *E. coli* biofilms developed on lettuce. This study also demonstrated that produce storage conditions, such as temperature, light and storage time had interactive effects on bacterial proliferation, internalisation, stress response and susceptibility to the ACP treatment, highlighting the importance of preventive measures as key factors for the assurance of microbiological safety of fresh produce.

Significant reductions of *P. aeruginosa* quorum sensing (QS)-regulated virulence factors, such as pyocyanin and elastase production, were achieved, suggesting that ACP technology could be a potential QS inhibitor and may play an important role in attenuation of virulence of pathogenic bacteria.

Despite the varying parameters that influenced plasma bactericidal activity, high voltage in-package atmospheric air ACP decontamination approach showed an efficient reduction of high concentrations of bacteria in liquids, associated with produce and bacteria in their most resistant, biofilm form. These results represent significant technological advances in non-thermal bactericidal treatment with a key advantage of elimination of post-processing contamination of the product, thereby increasing microbiological safety and extension of produce shelf life.

Declaration

I certify that this thesis which I now submit for examination for the award of Doctor of Philosophy, is entirely my own work and has not been taken from the work of others, save and to the extent that such work has been cited and acknowledged within the text of my work.

This thesis was prepared according to the regulations for postgraduate study by research of the Dublin Institute of Technology and has not been submitted in whole or in part for another award in any other third level institution. The work reported on in this thesis conforms to the principles and requirements of the DIT's guidelines for ethics in research.

DIT has permission to keep, lend or copy this thesis in whole or in part, on condition that any such use of the material of the thesis be duly acknowledged.

Signature _____ Date _____

Acknowledgments

I wish to express my gratitude to my supervisors, Dr. Paula Bourke and Dr. PJ Cullen, for providing me opportunity to join their research group in the first instance and for their tremendous amount of valuable guidance and encouragement throughout the work. I would like to extend my sincere thanks to Dr. Sonal Patil, who kindly shared her knowledge and experience with me and provided valuable suggestions and corrections during my research.

I would like to thank all academic and technical staff for their assistance and help.

I would like to acknowledge the financial support from the European Community's Seventh Framework Program (FP7/2207-2013).

Finally, many special thanks to my family and friends for their patience, understanding and support over the past years.

Abbreviations

°C	degrees Celsius
CFU	colony forming units
cm	centimetres
CO ₂	carbon dioxide
g	gram
h	hour
H ₂ O ₂	hydrogen peroxide
HCl	hydrochloric acid
Hz	hertz
kV	kilovolts
L	litre
M	molar
mg	milligram
MHz	megahertz
min	minute
mJ/cm ²	mega joule per cm square
ml	millilitre
mM	millimolar
mm	millimetre
NaCl	sodium chloride
nm	nanometre
p-p	peak to peak

ppm	parts per million
RMS	root mean square
rpm	revolutions per minute
s	second
V	volts
v/v	volume per volume
w/v	weight per volume
μl	microliter
μm	micrometre

Table of content

Chapter 1: INTRODUCTION	9
1.1. Benefits associated with consumption of fresh fruit and vegetables	9
1.2. Microbiological issues associated with fresh produce	10
1.3. Foodborne pathogens	14
1.3.1. <i>Escherichia coli</i>	14
1.3.2. <i>Listeria monocytogenes</i>	15
1.3.3. <i>Salmonella</i>	16
1.3.5. <i>Pseudomonas</i>	18
1.4. Microbial resistance	20
1.4.1. General stress responses.....	20
1.4.2. Biofilms	22
1.4.3. Viable but not culturable state of bacteria.....	26
1.4.4. Quorum sensing	29
1.5. Sources of contamination of fresh produce	33
1.6. Current trends in decontamination of fresh produce	34
1.6.1. Chlorine	36
1.6.2. Organic acids	37
1.6.3. Hydrogen peroxide	39
1.6.4. Ozone	40
1.7. Atmospheric cold plasma technology	43
1.7.1. Dielectric barrier discharge ACP	45
1.7.2. ACP jets	46
1.8. Applications of ACP	47
1.8.1. Surface processing	47
1.8.2. Air pollution.....	48
1.8.3. Plasma in medicine	49
1.8.4. Wastewater treatment	50
1.8.5. ACP as a food processing technology	51
1.9. Mechanism of action of ACP	56
1.10. Objectives	59
Chapter 2: MATERIALS AND METHODS	61
2.1. Bacterial strains and growth conditions	61
2.2. Cultivation of CHO-K1 cells	63
2.3. Liquid systems preparation	63
2.3.1. Preparation of MRD and PBS bacterial cell suspensions	63
2.3.2. Preparation of Methylene Blue aqueous solution.....	63
2.3.3. Effect of reduced pH on bacterial cell proliferation	64
2.3.4. Preparation of lettuce broth and inoculation procedure	64
2.3.5. Preparation of <i>P. aeruginosa</i> cell suspension and supernatant	65

2.4. Fresh produce preparation	65
2.4.1. Preparation of cherry tomatoes and strawberries.....	65
2.4.2. Inoculum preparation.....	66
2.4.3. Inoculation procedure.....	66
2.5. Bacterial biofilm formation on abiotic surface	67
2.5.1. Inoculum preparation.....	67
2.5.2. Biofilm formation.....	67
2.6. Bacterial internalisation and biofilm formation on lettuce	68
2.6.1. Preparation of lettuce.....	68
2.6.2. Inoculum preparation.....	68
2.6.3. Inoculation procedure.....	69
2.6.4. Internalisation and biofilm formation.....	69
2.7. Experimental design	70
2.7.1. ACP systems set-up.....	70
2.7.2. Samples position with respect to the ACP discharge.....	72
2.7.3. ACP treatment of liquid systems.....	73
2.7.4. ACP treatment of fresh produce.....	74
2.7.5. ACP treatment of bacterial biofilms on abiotic surface.....	75
2.7.6. ACP treatment of <i>P. aeruginosa</i> (QS studies).....	75
2.8. Post ACP treatment analysis	76
2.8.1. Liquid systems.....	76
2.8.1.1. Microbiological analysis.....	76
2.8.1.2. The effect of reduced pH.....	76
2.8.1.3. Analysis of MB discoloration rate.....	76
2.8.1.4. pH measurements.....	77
2.8.2. Fresh produce: cherry tomato and strawberry.....	77
2.8.3. Bacterial biofilms formed on abiotic surfaces.....	78
2.8.3.1. Crystal violet assay.....	79
2.8.3.2. Colony count assay.....	79
2.8.3.3. XTT assay.....	80
2.8.3.4. CLSM analysis of <i>P. aeruginosa</i>	80
2.8.4. Bacterial biofilms and internalised bacteria formed on lettuce.....	81
2.8.4.1. CLSM analysis of <i>E. coli</i>	81
2.8.5. SEM analysis.....	82
2.8.6. Intracellular reactive oxygen species (ROS) measurements.....	83
2.8.7. Quorum sensing assays.....	84
2.8.7.1. Pyocyanin assay.....	84
2.8.7.2. Elastin-Congo red assay.....	85
2.8.7.3. Planktonic cell population density.....	86
2.8.7.4. Biofilm formation.....	86
2.8.7.5. Cytotoxicity assay.....	86
2.8.7.6. Temperature measurements.....	87
2.8.9. Ozone measurements.....	87
2.9. Optical Emission Spectroscopy (OES)	88
2.10. Statistical analysis	88

Chapter 3: ACP DECONTAMINATION OF LIQUID SYSTEMS.....	90
3.1. Effect of treatment time, post treatment storage time, mode of exposure and media composition on ACP inactivation efficiency	90
3.2. Effect of voltage on ACP inactivation efficiency	97
3.3. Effect of gas composition on ACP decontamination efficiency	98
3.4. Effect of ACP treatment on methylene blue discoloration rate.....	101
3.5. Ozone concentration measurements.....	103
3.6. Samples pH measurements.....	105
3.7. SEM analysis	106
3.8. Optical Emission Spectroscopy (OES).....	107
3.9. Discussion.....	108
3.10. Conclusion	117
Chapter 4: ACP DECONTAMINATION OF FRESH PRODUCE	118
4.1. Inactivation of bacteria on cherry tomatoes	119
4.2. Inactivation of bacteria on strawberries	120
4.3. Inactivation of background microflora on produce.....	121
4.4. Ozone generation.....	124
4.5. SEM analysis	125
4.6. Discussion.....	125
4.7. Conclusion	133
Chapter 5: ACP INACTIVATION OF BACTERIAL BIOFILMS ON ABIOTIC SURFACE.....	134
5.1. Bacterial biofilm quantification by crystal violet assay	135
5.2. Effect of ACP treatment on bacterial biofilms	136
5.2.1. Colony count assay.....	136
5.2.2. XTT assay	139
5.2.3. SEM analysis	142
5.3. Discussion.....	143
5.4. Conclusion	150
Chapter 6: ACP INACTIVATION OF BACTERIAL BIOFILMS AND ASSOCIATED BACTERIA INTERNALISED IN LETTUCE.....	151
6.1. Effect of ACP on planktonic bacterial populations in lettuce broth	152
6.2. Effect of ACP on bacterial populations inoculated on lettuce.....	153
6.3. Effect of ACP on internalised bacteria and bacterial biofilms formed on lettuce at room temperature in light/dark photoperiod	154
6.4. Effect of ACP on internalised bacteria and bacterial biofilms formed on lettuce at 4°C in light/dark photoperiod.....	155
6.5. Effect of ACP on internalised bacteria and bacterial biofilms formed on lettuce at 4°C in dark	156
6.6. CLSM analysis	158

6.7. SEM analysis	159
6.8. ROS measurements	161
6.9. Ozone measurements.....	162
6.10. Discussion	162
6.11. Conclusion	170
Chapter 7: ACP INACTIVATION OF <i>P. AERUGINOSA</i> BIOFILMS AND INHIBITION OF QUORUM SENSING-REGULATED VIRULENCE FACTORS	172
7.1. Biofilm assays	173
7.1.1. CV assay	173
7.1.2. Colony count assay.....	174
7.1.3. XTT assay	175
7.1.4. CLSM analysis.....	176
7.1.5. SEM analysis	179
7.2. Effect of ACP on quorum sensing-regulated virulence factors	181
7.3. Effect of ACP on cytotoxicity of <i>P. aeruginosa</i>	185
7.4. Discussion.....	186
7.5. Conclusion	196
Chapter 8: GENERAL CONCLUSIONS AND FUTURE RECOMMENDATIONS	198
.....	
References.....	207
Peer reviewed publications	255
Congress and conferences	256
Awards	258

Table of figures

Figure 1: Schematic model of biofilm formation (<i>Bacillus subtilis</i>).....	23
Figure 2: Schematic diagram of DBD system.	46
Figure 4: DBD ACP systems.....	72
Figure 5: Position of samples inside polypropelene container with respect to the ACP discharge.....	73
Figure 6: Effect of post treatment storage time on antimicrobial efficacy of ACP treatment against <i>E. coli</i> . Treatment time 300 s.....	92
Figure 7: Effect of post treatment storage time (1 h and 24 h) on antimicrobial efficacy of ACP treatment against <i>E. coli</i> . Treatment time 60 s.....	94
Figure 8: Effect of treatment time on ACP antimicrobial efficacy against <i>E. coli</i> .	96
Figure 9: Effect of voltage level on ACP antimicrobial efficacy against <i>E. coli</i> . Treatment time 30 s, post treatment storage time 24 h.....	98
Figure 10: Effect of gas composition on ACP antimicrobial efficacy against <i>E. coli</i> . Treatment time 30 s, post treatment storage time 24 h.....	100
Figure 11: Effect of ACP treatment on <i>E. coli</i> and methylene blue.	102
Figure 12: Generation of ozone inside a sealed package during 30 s of either direct or indirect ACP generated using different gas mixtures.	104
Figure 13: Effect of MRD acidic pH on proliferation of <i>E. coli</i>	106
Figure 14: SEM images of <i>E. coli</i> treated with ACP for 30 s and stored for 24 h.	107
Figure 15: Emission spectrum of DBD ACP operating in air under atmospheric pressure.....	108
Figure 16: ACP inactivation efficacy against bacteria inoculated on cherry tomatoes.....	119
Figure 17: ACP inactivation efficacy against bacteria inoculated on strawberries.	121
Figure 18: ACP inactivation efficacy against background microflora of produce.	123

Figure 19: Generation of ozone inside a sealed package during ACP treatment of produce.	124
Figure 20: SEM images of untreated bacteria inoculated on produce.	125
Figure 21: Bacterial biofilm formation after 24 h and 48 h of incubation evaluated by CV assay.	135
Figure 22: Surviving populations of 48 h bacterial biofilms assessed by colony count assay.	138
Figure 23: Percentage surviving populations of 48 h bacterial biofilms assessed by XTT assay.	141
Figure 24: SEM images of <i>E. coli</i> 48 h biofilm.	142
Figure 25: Effect of ACP treatment (30 s) and post treatment storage time (24 h at 4°C) on bacteria suspended in lettuce broth (3%).	152
Figure 26: Effect of ACP treatment (300 s) and post treatment storage time (24 h at 4°C) on bacteria inoculated on lettuce.	153
Figure 27: Effect of ACP treatment (300 s) and post treatment storage time (24 h at 4°C) on bacterial biofilms formed on lettuce at room temperature in light/dark photoperiod.	155
Figure 28: Effect of ACP treatment (300 s) and post treatment storage time (24 h at 4°C) on bacterial biofilms formed on lettuce at 4°C in light/dark photoperiod.	156
Figure 29: Effect of ACP treatment (300 s) and post treatment storage time (24 h at 4°C) on bacterial biofilms formed on lettuce at 4°C in dark.	158
Figure 30: CLSM images of <i>E. coli</i> XL10 (GFP) 24 h biofilms formed on lettuce.	159
Figure 31: SEM images of <i>Salmonella</i> 48 h biofilms formed on lettuce at room temperature and light/dark photoperiod.	160
Figure 32: Concentration of ROS generated after 30 s of indirect ACP treatment inside bacterial cells.	161
Figure 33: <i>P. aeruginosa</i> biofilm formation.	174
Figure 34: Surviving populations of <i>P. aeruginosa</i> 48 h biofilms assessed by colony count assay.	175

Figure 35: Percentage surviving populations of <i>P. aeruginosa</i> 48 h biofilms assessed by XTT assay.	176
Figure 36: CLSM images of <i>P. aeruginosa</i> 48 h biofilms stained with LIVE/DEAD bacterial viability kit.	178
Figure 37: SEM images of <i>P. aeruginosa</i> 48 h biofilms.	180
Figure 38: ACP inhibition effects on <i>P. aeruginosa</i> QS-regulated virulence factors.	184
Figure 39: The effect of either untreated (0 h, 24 h controls) or ACP treated <i>P. aeruginosa</i> (P.a) and ACP treated TSB medium on growth/adherence of CHO-K1 cells.	186

List of tables

Table 1: Published research on the inactivation of bacteria on fresh produce by ACP treatment.	54
Table 2: List of microorganisms, their origin, growth media, substrate and ACP system applied.	62
Table 3: ACP treatment times and corresponding concentrations of ozone, measured immediately after the treatment.	103
Table 4: Effect of direct and indirect ACP treatment accompanied with 24 h of post treatment storage on MRD pH.	105

Chapter 1: INTRODUCTION

1.1. Benefits associated with consumption of fresh fruit and vegetables

Fresh fruit and vegetables are an important part of a healthy diet. The ‘5-a-Day’ program developed in 1989 by a National Academy of Sciences (USA) recommended five or more servings of fresh fruits and vegetables daily, and increased public awareness of the health benefits associated with consumption of fruit and vegetables (Liu 2003). Globally, between 2000 and 2011, the world production of fresh fruits and vegetables grew by 38% (Kirezieva *et al.* 2013). Numerous in-vivo, in-vitro, pre-clinical and clinical investigations on the beneficial influences of fresh foods has been indicated on reduced risks of cardiovascular disease, cancer, diabetes, metabolic and Alzheimer disease, etc. (van Duyn and Pivonka 2000; Liu 2003; Dai *et al.* 2006; van Breda *et al.* 2008; Wang *et al.* 2010; Wootton-Beard and Ryan 2011; Manchali *et al.* 2012). The link between the rich in fruits and vegetables diet and health mainly contributes to produce constituents such as vitamins, minerals, fiber, complex carbohydrates and recently isolated phytonutrients – biologically active organic compounds responsible for protection against disease in plants (Olmez 2012). For example, yellow-orange vegetables and fruits, such as carrots, sweet potatoes, winter squash, cantaloupe, and mango, are rich sources of antioxidant (beta carotene, a carotenoid), which may protect cell membranes and DNA from oxidative damage. Vitamin C, which is found in citrus fruits, lutein, which is found in green leafy vegetables (spinach), and lycopene, which is found in fruits and vegetables of deep-red colour, are also antioxidants. Dark-green leafy vegetables and some citrus

fruits are also good sources of folic acid, which may have a protective role at the molecular level in cancer development (van Duyn and Pivonka 2000; Reiss *et al.* 2012). Major nutritional components of cruciferous vegetables, are protein, carbohydrate and vitamins. It is well-known that even minimal processing of fruits and vegetables (washing, cutting, disinfecting, packaging, storage conditions) promotes a faster physiological deterioration, biochemical changes and microbial degradation of the product, leading to a reduction in produce nutritional quality as well as the produce shelf-life (Allende *et al.* 2006; Francis *et al.* 2012; Gil and Allende 2012).

Widely available information on nutritional composition of fresh fruit and vegetables has increased consumer's awareness about the benefits associated with diverse diet. This maintains a high demand for a wide range of pre-packed ready to use products. Moreover, consumers expect fresh produce year-round, packaged for convenience with fewer preservatives, high nutritive value and fresh sensory attributes, available at a reasonable price. Therefore, to gain maximum health benefits of bioactive compounds in fruit and vegetables, the use of optimised minimal processing technology is necessary in order to retain nutritional quality as well as to maintain microbiological safety of these produce.

1.2. Microbiological issues associated with fresh produce

To obtain the maximum nutritional benefits, fresh fruits and vegetables are commonly consumed raw or minimally processed. Despite the beneficial health effects, minimally processed fresh produce can be a vehicle for the transmission of bacterial, parasitic and viral pathogens capable of causing human illness (Abadias

et al. 2008). Foodborne human illnesses resulting from consumption of contaminated fresh produce have been widely reported throughout the world. In the EU in 2009 and 2010, respectively, 4.4% and 10% of the foodborne verified outbreaks were linked with the consumption of vegetables, fruits and berries (van Boxstael *et al.* 2013). Most reporting countries identified *Escherichia coli* O157:H7, *Listeria monocytogenes* and *Salmonella* spp. as the target pathogens of concern (Raybaudi-Massilia *et al.* 2009; Olaimat and Holley 2012). Fresh produce implicated in recent illness outbreaks caused by contamination with *E. coli*, *Salmonella* and *L. monocytogenes* are spinach, lettuce, radish, alfalfa sprouts, tomatoes, peppers, cantaloupe, strawberries and fruits and vegetable salads (Olaimat and Holley 2012). In the USA from 1973 – 1997 *Salmonella* was responsible for nearly half of the outbreaks due to bacteria and it remains implicated in a number of recently documented outbreaks of illnesses (Berger *et al.* 2010; Olaimat and Holley 2012). In the EU *Salmonella* Enteritidis and Typhimurium serovars are recognised as the most frequently associated with outbreaks of foodborne illness (Fernandez *et al.* 2013). *E. coli* O157 foodborne outbreaks have become increasingly common: from 1982 to 2002, a total of 350 outbreaks were reported in the USA (Rangel *et al.* 2005). In 2006 in the USA there was a multi-state outbreak of *E. coli* O157:H7 implicating spinach, and 276 cases of foodborne illness and three deaths were reported (Goodburn and Wallace 2013). In 2011, a large *E. coli* associated outbreak occurred in Germany, which involved 3911 cases of illness with 47 deaths (Olaimat and Holley 2012). *Listeria* is an important cause of human illness in the USA, which in 2011 caused a lethal

outbreak with a total of 147 infected persons, with 33 deaths were reported (Weingrow 2012). Pathogens that reside in the protected sites of fresh produce increase bacterial survivability for long periods of time beyond the expected shelf life and often despite detrimental for growth environmental conditions (Olaimat and Holley 2012). For example, Flessa *et al.* (2005) reported that *L. monocytogenes* is capable of survival on the surface of fresh intact or cut strawberries throughout the expected shelf life of the fresh fruit and can survive on frozen strawberries for periods of at least 4 weeks.

The principal factors that enhance propagation of pathogenic and spoilage bacteria on fresh produce, thus making products more susceptible to spoilage, are high water content and wounding of such produce during harvesting and transport (Spadaro and Gullino 2004). Deterioration of fresh produce, as a consequence of microbiological spoilage, is accompanied with unpleasant odours, tastes, and textures and may constitute a hazard for consumers by possible presence of microbial toxins (Zheng *et al.* 2013). Current trends of using fewer fungicides may lead to an increase in numbers of moulds present on fresh produce, therefore, allowing increased mycotoxins production (van Boxtael *et al.* 2013). Consumption of raw or minimally processed products may also influence the development of allergies (Leff and Fierer 2013). Environmental factors contributing to the composition of the microbial community include pH and moisture availability, which can vary across produce types. Recent study conducted by Jensen *et al.* (2013), demonstrated the presence of 34 different species from 23 different genera for bacteria and 22 different species from 9

different genera for yeasts identified in strawberry samples. Differences in growing conditions, such as farming practices (conventional versus organic), transport procedures and storage conditions may also have an impact on the proliferation, diversity and composition of produce microbial communities (Leff and Fierer 2013).

The causal agents of microbiological spoilage in fruits can be bacteria, as well as yeasts and moulds. Some bacteria such as *Erwinia* spp., *Enterobacter*, *Propionibacterium chlohexanicum*, *Pseudomonas* spp., and lactic acid bacteria have been reported as deteriorative in cut fruit and juices. Moulds, such as *Penicillium* spp., *Aspergillus* spp., *Eurotium* spp., *Alternaria* spp., *Cladosporium* spp., *Paecilomyces* spp., and *Botrytis* spp. involved in the spoilage of fresh fruits and some processed fruit derivatives including the thermally processed. Yeasts, such as *Saccharomyces* spp. *Cryptococcus* spp., and *Rhodotorula* spp. in fresh fruits, and *Zygosaccharomyces* spp., *Hanseniaspora* spp., *Candida* spp., *Debaryomyces* spp., and *Pichia* spp. are found in dried fruits (Raybaudi-Massilia *et al.* 2009).

Nutrient composition and high pH of vegetables will allow growing a range of Gram negative bacteria (Gram *et al.* 2002). Total counts of bacterial populations on minimally processed vegetables range from 3.0 to 6.0 log CFU/g. The dominating bacterial population during low temperature storage mainly consists of species belonging to the *Pseudomonadaceae* and *Enterobacteriaceae* (e.g., *Erwinia herbicola* and *Rahnella aquatilis*), besides some species belonging to the lactic acid bacteria (*Leuconostoc mesenteroides*). *Pseudomonas* spp. normally dominates

and may make up 50–90% of the microbial population on many vegetables (Ramos *et al.* 2013). Many different yeast species have been identified in minimally processed vegetables, including species of *Candida*, *Cryptococcus*, *Rhodotorula*, *Trichosporon*, *Pichia* and *Torulasporea*. Moulds are less important in minimally processed vegetables due to the intrinsic properties, such as a slightly acidic to neutral pH favouring bacteria and yeasts, which will overgrow moulds (Ragaert *et al.* 2007).

1.3. Foodborne pathogens

In 2011, bacterial pathogens were considered to be the most important food safety issue for fresh produce, followed by foodborne viruses, pesticide residues and mycotoxins (van Boxtael *et al.* 2013). The following are the pathogens which are of safety concern identified for fruits and vegetables eaten raw: *Salmonella* spp., *Shigella* spp., *E. coli*, *Campylobacter*, *Yersinia enterocolitica*, *Listeria monocytogenes*, *Staphylococcus aureus*, *Clostridium* spp., *Bacillus cereus*, and *Vibrio* spp. (Goodburn and Wallace 2013). General characteristics of several pathogens, which are of the greatest food safety concern, are given in the following subsections.

1.3.1. Escherichia coli

E. coli are Gram-negative, short rod-shaped bacteria and members of the family Enterobacteriaceae. In humans, *E. coli* is the most common facultative anaerobe in the gastrointestinal tract and this is also the organism's natural habitat in other mammals and warm-blooded animals. Most of *E. coli* present in gut flora are harmless, but there are a number of pathogenic forms that are able to cause a wide

diversity of human diseases, ranging from mild diarrhoea to cholera-like diarrhoea and invasive dysentery, as well as urinary tract infections, septicaemia and meningitis (McClure 2005). The infectious dose of *E. coli* is very low, fewer than 100 cells (Alam and Zurek 2004). Diarrheagenic *E. coli* is categorised into specific groups based on virulence properties, mechanism of pathogenicity, clinical syndromes and distinct O:H serotypes. Enterohemorrhagic *E. coli* (EHEC) O157:H7 is recognised as the most predominant serotype, which causes the most severe illness. *E. coli* O157:H7 was first identified as a foodborne pathogen in 1982, when it was identified as the cause of two outbreaks of bloody diarrhoea. Since then, reports on foodborne illnesses caused by *E. coli* had steadily increased. Unlike most of foodborne pathogens, many strains of *E. coli* O157:H7 are unusually tolerant to acidic environments (Montville *et al.* 2012). This ability is essential for its survival in the mammalian digestive system where pH can vary between 2 and 8. More importantly, induction of acid tolerance in *E. coli* can also increase tolerance to other environmental stresses, such as heating, radiation and antimicrobials, which significantly contributes to the pathogenesis of this organism (Richard and Foster 2003; Montville *et al.* 2012).

1.3.2. *Listeria monocytogenes*

L. monocytogenes is a Gram-positive rod-shaped, facultative anaerobe and is the agent of the disease listeriosis, a serious infection caused by eating contaminated food. Listeriosis is sporadic and rare, but it is severe and is the third leading cause of death due to foodborne illness. Approximately 15.9% of people who get listeriosis die from it (Montville *et al.* 2012). The infectious dose of *L.*

monocytogenes is fewer than 100 cells and depends on the immunological status of the human, virulence of the microbe and the source. It can cause meningitis, septicaemia and abortion. Unlike other pathogenic bacteria, which excrete toxins or multiply in the blood, *L. monocytogenes* enters the host's cells, grows inside the cell and passes directly to nearby cells. This membrane permeability allows bacteria to cross into the brain and placenta, and this reduces the bacterium's exposure to antibiotics and circulating antibodies (Montville *et al.* 2012). The *Listeria* spp. are widely distributed in nature and are tolerant to extreme conditions such as low pH, low temperature and high salt conditions, therefore, they can be found in a variety of environments, including soil, sewage, water, effluents and isolated from a variety of foods (Jeyaletchumi *et al.* 2010). Implicated foods include ready-to-eat fresh produce, milk and dairy products, meat and poultry and seafoods. *L. monocytogenes* does not survive heat processing and gets into the processed foods primarily by post process contamination. In addition, *L. monocytogenes* survives for long periods making this bacteria control difficult for the food industry (Montville *et al.* 2012).

1.3.3. *Salmonella*

Salmonella is facultative anaerobe, Gram-negative rod-shaped bacteria, belonging to the family *Enterobacteriaceae* (Montville *et al.* 2012). It is among the most commonly isolated foodborne pathogens associated with fresh fruits and vegetables. Outbreaks of salmonellosis have been linked to a wide variety of fresh fruits and vegetables including apple, cantaloupe, alfalfa sprout, mango, lettuce, cilantro, unpasteurized orange juice, tomato, melon, celery and parsley (Pui *et al.*

2011). The genus *Salmonella* consists of two species, *Salmonella enterica* and *S. bongori*. *S. enterica* is further divided into six subspecies: *S. enterica* subsp. *enterica*, *S. enterica* subsp. *salamae*, *S. enterica* subsp. *arizonae*, *S. enterica* subsp. *diarizonae*, *S. enterica* subsp. *houtenae*, *S. enterica* subsp. *indica* (Forshell and Wierup 2006). More than 2,400 serovars are known. *Salmonella* serovars that have been linked to recent cases of foodborne illness include *S. enterica* serovars Enteritidis, Typhimurium, Newport and Stanley (Montville *et al.* 2012). *S. enterica* serovars Enteritidis and Typhimurium harbour a virulence plasmid, which genes are induced by growth restriction, such as reduced nutrient supply or lowered pH and responsible for the production of endotoxins and exotoxins (Forshell and Wierup 2006). Human *Salmonella* infections can lead to several clinical conditions, including enteric (typhoid) fever, uncomplicated enterocolitis and systemic infections by nontyphoid microorganisms, which are a serious human diseases associated with diarrhoea, nausea, prolonged fever, abdominal pain, and headache. New-borns, infants, the elderly and immunocompromised individuals are more susceptible to *Salmonella* infections than healthy adults (Montville *et al.* 2012). Although, a fatal outcome is rare, infected patients may encounter serious complications such as typhoid encephalopathy, gastrointestinal bleeding and intestinal perforation (Forshell and Wierup 2006; Pui *et al.* 2010). The infectious dose may vary from fewer cells to thousands depending on the virulence of the infecting strain as well as chemical composition of the contaminated food (low infectious doses are likely associated with high fat content) (Montville *et al.* 2012). *Salmonella* is resilient and can adapt to extreme environmental conditions. They

are sensitive to heat and often killed at temperature of 70°C or above (Pui *et al.* 2011). However, *Salmonella* Typhimurium and Enteritidis can grow at elevated temperatures (54°C) or in foods stored at 2-4°C surviving for extended periods. *Salmonella* is able to grow at the pH values ranging from 4.5 to 9.5, with an optimum pH for growth of 6.5 to 7.5. Acid stress can also enhance bacterial resistance to other environmental stresses. The growth of serovar Typhimurium at pH 5.8 increases thermal resistance at 50°C and enhances the tolerance to high osmotic stress (>2% NaCl) (Montville *et al.* 2012).

1.3.5. *Pseudomonas*

Pseudomonas spp. are Gram-negative, motile, obligate aerobic rod-shaped mesophilic bacteria, which are widely distributed in nature. *Pseudomonas* spp., including *P. aeruginosa*, contribute to spoilage of fresh produce and have been isolated from various types of vegetables such as celery, potato, lettuce, carrots, cucumbers, tomatoes and cabbage (Barth *et al.* 2011; Schwaiger *et al.* 2011; Allydice-Francis and Brown 2012). Pseudomonads are heat sensitive, and are not found in heat-processed foods. However, these microorganisms are able to grow at refrigeration temperature and have been found in a variety of frozen and refrigerated foods, including fresh-cut produce (Barth *et al.* 2011).

P. aeruginosa is one of the most important species of *Pseudomonas* genus and is a common opportunistic nosocomial pathogen, which causes a wide variety of acute and persistent infections in immunocompromised patients (Mena and Gerba 2009). *Pseudomonas* associated health care infections include respiratory tract infections, urinary tract infections, surgical and burn wound infections, and bloodstream

infections (Tredget *et al.* 2004; Mittal *et al.* 2009; Scheetz *et al.* 2009; Doring 2010; Jombo *et al.* 2010; Fujii *et al.* 2014). In addition to clinical importance, *P. aeruginosa* also impacts on industry due to the evidence of infection acquired in healthy individuals (Hatchette *et al.* 2000). In healthy hosts, *P. aeruginosa* is responsible for eye, ear and skin infections, acquired from contact with contaminated water (Mena and Gerba 2009). *P. aeruginosa* is the best studied species of the pseudomonads due to prevalence, high adaptability, virulence/pathogenicity, increasing resistance to antimicrobial treatments, and associated cause of morbidity and mortality (Lambert *et al.* 2011; Sydnor and Perl 2011; Venier *et al.* 2014). Many environmental strains of *P. aeruginosa* are able to resist ampicillin, ceftiofur, florfenicol, sulphachloropyridazine, sulphadimethoxine and trimethoprim/sulfamethoxazole, chlortetracycline and spectinomycin (Kaszab *et al.* 2011). *P. aeruginosa* general mechanism of antibiotic resistance comprise following factors: low permeability of its cell wall (restricted uptake and efflux, production of antibiotic-inactivating enzymes), capacity to express a wide repertoire of resistance mechanisms, mutation in chromosomal genes which regulate resistance genes, acquisition of additional resistance genes from other organisms via plasmids, transposons and bacteriophages (Lambert 2002; Mesaros *et al.* 2007). Another aspect that plays a major role in *P. aeruginosa* resistance is its tendency to form biofilm on a variety of living and non-living surfaces, and this microorganism is widely considered as model organism to study Gram-negative biofilms (Sharma *et al.* 2014).

Because all of the above microorganisms can attach on different types of surfaces during food processing and preparations, including processing equipment, produce surfaces, drains and pipes, on which bacteria may further develop into biofilms and cause cross-contamination, proper produce sanitation is becoming difficult. Considering broad spectrum of habitat, virulence, low infectious doses of these pathogens, it is critical to investigate the efficacy of a novel high voltage ACP technology against these challenge microorganisms.

1.4. Microbial resistance

1.4.1. General stress responses

Microorganisms on the surface of fruits and vegetables encounter a variety of stresses during production, harvest, post-harvest handling including extreme temperatures, nutrient deprivation and fluctuations in the availability of water (Delaquis and Bach 2012). Bacteria may undergo stresses during food processing including mild heating, freeze–thaw injury, osmotic stress, acid stress and biocide treatment (Dodd *et al.* 2007). For instance, *Salmonella* can survive in a diverse range of stressful environments such as pH ranging from 3.99 and 9.5, salt concentrations up to 4% w/v NaCl and temperatures as high as 54°C or low as 2°C (Spector and Kenyon 2012). Consequently, these stresses can have a significant effect on the bacterial survival during food processing impacting the efficacy of antimicrobial treatments. Bacterial stress response is based on the genetic regulatory factors (sigma factor), which will bind to and alter the specificity of RNA polymerase (RpoS). This leads to the synthesis of a range of proteins with the function to improve the survivability of the cells. Mediated by RpoS, general stress

response is induced by nutrient starvation, osmotic shock, extreme temperatures, pH and oxidative stress (Delaquis and Bach 2012). For example, *E. coli* possesses three different acid resistance mechanisms (Warnecke and Gill 2005). These systems include an acid-induced oxidative system, which requires the presence of RpoS; arginine dependent and acid-induced under anaerobic conditions system, which requires the presence of arginine decarboxylase, and glutamate dependent and stationary phase induced system, that requires the presence of glutamate decarboxylase (Richard and Foster 2003; Montville *et al.* 2012). Furthermore, many aerobic microorganisms have intrinsic resistance to reactive oxygen species (ROS) (Delaquis and Bach 2012). Reactive oxygen species (ROS), such as superoxide anion, hydroxyl radical, hydrogen peroxide, and singlet oxygen, are continuously produced as side products of bacterial respiration and other metabolic pathways (Cabiscol *et al.* 2000), which can damage several cellular sites, including iron-sulfur clusters, cysteine and methionine protein residues, and DNA (Chiang and Schellhorn 2012). In turn, ROS can be degraded to some extent by enzymes including peroxidases, catalases and reductases (Delaquis and Bach 2012). When the balance between the ROS production and elimination is disturbed it may lead to the oxidative stress (Lushchak *et al.* 2011). The oxidative stress responses, therefore, are necessary to ensure survival of organisms in aerobic conditions (Chiang and Schellhorn 2012). For example, in *E. coli* the gene regulatory response to superoxide and peroxide stress is largely mediated through the induction of superoxide dismutases and catalases, respectively (Chiang and Schellhorn 2012). Continuous exposure of bacteria to sub-lethal stresses may lead

to a homologous resistance, i.e. lead to the increased resistance to subsequent applications of the same stress. Cebrian *et al.* (2010) exposing cells to sub-lethal acid and alkaline pH, hydrogen peroxide, and heat, demonstrated an increase in times for the first decimal reduction after exposure to a lethal dose of the respective treatments by a factor of 1.6, 2, 2, and 6, respectively. Furthermore, microorganisms that survive a given stress often gain resistance to the other unrelated stresses via cross-resistance or cross-protection, including environmental stress and stresses associated with food processing and preservation methods, e.g., heating, chilling, acidity, and alkalinity (Delaquis and Bach 2012). For example, Patil *et al.* (2009) demonstrated an increased resistance of *E. coli* to ozone treatment when cells were exposed to acidic environment for 1 h. Another study reported increase in antibiotic resistance of *L. monocytogenes* associated with an increase in salt concentration to 6 or 12%, reduction of pH to 5 and decrease in temperature to 10°C (Al-Nabulsi *et al.* 2015). Therefore, the risk associated with bacterial cross-protection should be always considered for food preservation systems as the use of sub-lethal stresses may induce the mechanisms responsible for bacterial resistance.

1.4.2. Biofilms

During the last decades, it has become increasingly clear that many human pathogens grow predominantly as biofilms on the surfaces of most of their habitats, rather than in planktonic mode (Giaouris *et al.* 2013; Sharma *et al.* 2014). Bacterial biofilms are broadly described as a microbially derived sessile community characterized by cells that are attached to a substratum or to each other and are

embedded in a matrix of extracellular polymeric substances (EPS), and exhibit an altered phenotype with respect to growth rate and gene transcription (Giaouris *et al.* 2013). According to Stoodley *et al.* (2002), formation of biofilm consists of several stages: initial attachment of cells to the surface, production of EPS resulting in more firmly adhered “irreversible” attachment, early development of biofilm architecture, maturation of biofilm architecture and dispersion of single cells from the biofilm (Fig 1).

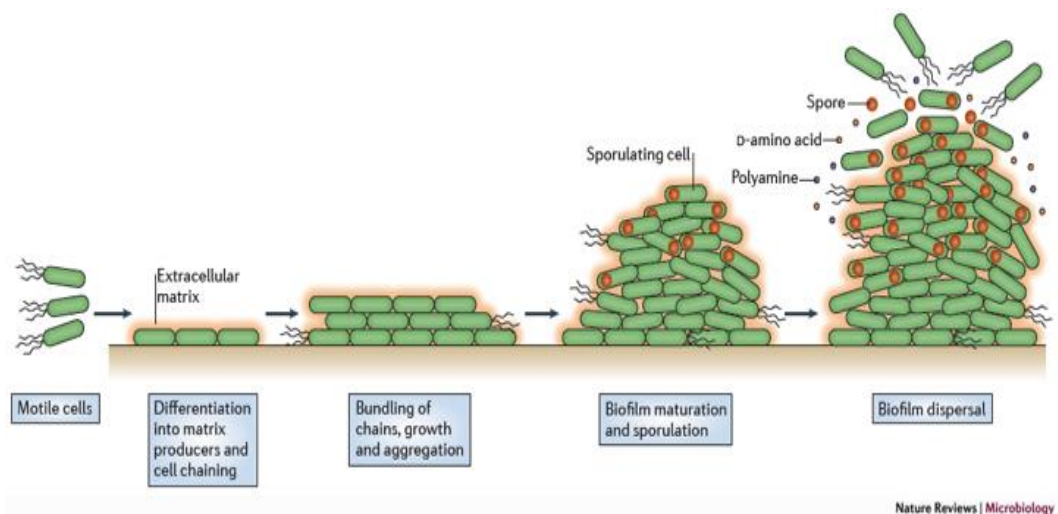

Figure 1: Schematic model of biofilm formation (*Bacillus subtilis*).

Adapted from Vlamakis *et al.* (2013).

Formation of bacterial biofilms on food contact surfaces, on food processing equipment and in potable water distribution systems contributes to food spoilage, cross-contamination of food products and spread of foodborne pathogens (Kim and Wei 2012). Moreover, biofilms are more resistant to various environmental stresses; therefore, represent a major challenge in food and biomedical industries

(Borges *et al.* 2013). EPS are the high-molecular-weight secretions from microorganisms and the products of cellular lysis and hydrolysis of macromolecules (Sheng *et al.* 2010). The composition of EPS matrix is complex and variable among different environmental conditions with exopolysaccharides and proteins being the major components (Kim and Wei 2012). Non-enzymatic proteins (lectins) are involved in the formation and stabilization of the polysaccharide matrix network and constitute a link between EPS and bacterial surface (Kim and Wei 2012). In addition, humic substances, lipids, nucleic acids, uronic acids and some inorganic components have also been found in EPS (Rodrigues *et al.* 2010). Bacteria in biofilms can be up to a thousand times more resistant to antimicrobials than the planktonic cells of the same species (Alkawareek *et al.* 2012a). Although the exact mechanisms that confer bacterial protection in biofilms are not fully understood, several mechanisms have been proposed. The first mechanism of biofilm resistance is the protective barrier properties of the EPS, which results in slow and incomplete penetration of antimicrobials into the biofilm. The second is a nutrient depletion or waste products accumulation, which alter metabolic activity of bacterial cells (Stewart and Costerton 2001). Biofilms containing metabolically quiescent cells may have important biological relevance, as the reduced metabolic needs and slowed growth may enable cells to survive unfavorable environmental conditions, and when favourable conditions are restored they can act as seed cells and contribute to an outbreak (Teschler *et al.* 2015). The third mechanism is related to the subpopulations of bacteria that exhibit distinct resistant phenotypes (persister

cells). Other mechanisms of biofilm resistance include the action of sub-lethal concentrations of antimicrobial agent cross-protection through the activity of a general stress response mechanism. The gene RpoS is often implicated in biofilm formation and is responsible for mediating gene expression during periods of stress, starvation, and stationary-phase growth (Sheldon *et al.* 2012; Borges *et al.* 2013). Production of enzymes (e.g., catalase) by bacteria in biofilms may be partly responsible for increased resistance to disinfectants containing hydrogen peroxide. Of clinical importance is the discovery that bacteria in biofilm may produce β -lactamase enzymes, enhancing resistance to β -lactam antibiotics (Lindsay and von Holy 2006). Horizontal gene transfer is another possible mechanism of heritable acquisition of resistance against antimicrobial agents in biofilms. One of the major mechanisms of horizontal gene transfer is plasmid-mediated bacterial conjugation (Krol *et al.* 2013). Conjugation requires close contact between cells, therefore efficiently occurs between the cells in biofilms rather than between planktonic cells (Kim and Wei 2012; Krol *et al.* 2013). In the United States approximately 80% of persistent bacterial infections were found to be associated with biofilms (Srey *et al.* 2014b), therefore biofilm resistance towards antimicrobial treatments should form part of the studies where antimicrobial effect of novel decontamination technology is investigated.

Another factor that could have a potential contribution to elevated resistance to antimicrobial agents is that bacterial pathogens can become internalized inside plant tissue. Bacterial internalization may occur through entering plant natural openings (e.g. hydathodes, stomata, lenticels) or physically damaged sites during

processing and is dependent on time, temperature, light, pressure, produce surface characteristics and the native endophytic microbial community (Kroupitski *et al.* 2009; Golberg *et al.* 2011; Deering *et al.* 2012; Gu *et al.* 2013a, b; O’Beirne *et al.* 2014).

Due to the various factors that can influence the microbiological quality of fresh produce, i.e. biofilm formation and cell internalization, implementation of effective decontamination steps within the production chain are required in order to ensure microbiological safety of pre-packaged, ready to eat fruit and vegetables. Therefore, this work includes investigations of the effects of novel cold plasma decontamination approach against challenge bacterial populations in their planktonic form, internalised bacteria and bacterial populations in their most resistant biofilm form.

1.4.3. Viable but not culturable state of bacteria

Colwell and co-workers were first to describe viable but not culturable (VBNC) state of bacteria in 1982 (Xu *et al.* 1982). It has been suggested that under one or more environmental stresses bacteria either in free-living form or in the form of biofilms can enter VBNC state (Brelles-Marino 2012; Ayrapetyan *et al.* 2015). Bacteria in the VBNC state fail to grow on the routine bacteriological media, on which they would normally grow and develop into colonies (Oliver 2005). The environmental stresses that may influence the culturability of cells include nutrient starvation, incubation outside the normal temperature range of growth, elevated or lowered osmotic concentrations, oxygen concentrations commonly used food preservatives, heavy metals and even exposure to white light (Oliver 2010). Many

common human pathogens, including *E. coli*, *L. monocytogenes*, *P. aeruginosa*, *S. enterica* Typhimurium, while remaining non-culturable can maintain apparent cell integrity, cellular structure, respiratory activity, remain physically active for cellular elongation and continuous gene expression and gain increased antibiotic resistance due to lower metabolic activity (Delaquis and Bach 2012; Fakruddin *et al.* 2013). For example, *Campylobacter jejuni* exists in two different cellular morphologies, where the atypical coccoid form, currently associated with the non-growing VBNC state, occurs under adverse growth conditions (Rowan 2004). Fernandez-Delgado *et al.* (2015) observed morphological changes occurred from rod to coccoid in *V. cholerae* cells in response to unfavorable aquatic environment, suggesting that *V. cholerae* can persist in the VBNC state in this environment and revert to a cultivable form under favorable conditions. It is recognized that cells in the VBNC state typically demonstrate very low levels of metabolic activity, and on resuscitation they are culturable again (Oliver 2010). However, in recent study Dolezalova and Lukes (2015) have demonstrated that VBNC *E. coli* could not be resuscitated; and because these cells were further confirmed to be metabolically active, the authors suggested that cells are rather in the active but non-culturable state. Bacteria in this state still possess the ability to be virulent. Several studies observed persisting bacterial pathogenicity when bacteria were no longer able to grow and form colonies (Dolezalova and Lukes 2015). VBNC cells, together with persister cells, which are also characterized with a non-growing state, are likely to be a substantial source of antibiotic failure and persistent infections (Ayrapetyan *et al.* 2015).

The inability to recover metabolically active cells is also a major problem in food-processing technology (Khan *et al.* 2010). Microbial pathogens in such a state may retain their capacity to cause infections after ingestion by the consumer despite their inability to grow under the conditions employed in procedures for determining their presence in foods. Heavily stressed pathogenic species of bacteria in a VBNC state are potentially dangerous for public health, particularly as stressed cells may be more virulent than well-fed bacteria (Rowan 2004). The study conducted by Dinu and Bach (2011) indicated that *E. coli* O157:H7 VBNC cells are induced on lettuce plants, which may result in further implications regarding the produce microbiological safety.

A large number of probes and methods enabling the physiological characterization of bacteria at the single-cell level have been developed recently. These methods involve fluorescence-based methods; they include nucleic acid staining, the double-staining method using epifluorescence microscopy, the measurement of respiratory activity with tetrazolium salts, the measurement of esterase activity with the ChemChrome fluorogenic substrate, estimation of bacterial membrane potential using rhodamine 123 and fluorescein diacetate, and the measurement of membrane integrity. LIVE/DEAD staining kits, flow cytometry methods and RT-PCR assays are also widely used for viability assessment (Khan *et al.* 2010).

Bacteria enter into VBNC state in response to one or more environmental stresses, therefore it should be expected that plasma generated reactive species may also induce this state in bacteria, possibly through oxidative stresses. To date, several studies focused on plasma bacterial inactivation used respiratory staining in order

to determine the absence of VBNC form or respiratory activity of bacteria (Joshi *et al.* 2010; Alkawareek *et al.* 2012b; Kvam *et al.* 2012; Sun *et al.* 2012; Dolezalova and Lukes 2015).

1.4.4. Quorum sensing

One of the regulatory mechanisms that bacteria employ to respond to external environmental stresses through the expression of a large number of genes is quorum sensing (QS), widely defined as a population-controlled bacterial communication process (Bhardwaj *et al.* 2013). QS regulates numerous important cell functions in both Gram-positive and Gram-negative bacteria, including metabolism, protein synthesis, expression of virulence factors, antibiotic resistance, biofilm formation, biofilm maintenance and dispersal, and entry to stationary phase, therefore, QS is a highly attractive target in the search for alternative antimicrobial agents (Smith and Iglewski 2003; Landini 2009; Bhardwaj *et al.* 2013). Bacterial QS is mediated by production and release of chemical signal molecules called autoinducers that increase in concentration as a function of cell density. The detection of a minimal threshold concentration of an autoinducer leads to an alteration in gene expression. Gram-positive and Gram-negative bacteria use QS to regulate a diverse array of physiological activities, which may occur both within and between bacterial species (Miller and Bassler 2001). QS operate through a wide range of signals such as oligopeptides, N-acyl homoserine lactones (AHL), furanosyl borate, hydroxyl-palmitic acid methylester, and methyl dodecanoic acid (Kalia 2013). The two most widely studied QS signals are AHL, produced by Gram-negative bacteria, which are diffusible, i.e., diffuse across the

cell membrane and bind to regulatory proteins within the cell, and peptide-based QS signals in Gram-positive bacteria, which are non-diffusible, i.e., produced as precursor peptides, modified and exported outside by membrane bound receptor histidine kinases. AHL are used by over 70 Gram-negative bacterial species (Lazar 2011; Kalia 2013). For example, *P. aeruginosa* possesses two AHL signalling systems, *las* and *rhl*. The *las* system consists of the signal synthase LasI, which produces N-3-oxo-dodecanoyl-homoserine lactone (3OC12-HSL), and the signal receptor LasR, which binds its cognate signal and activates transcription of certain target genes. The second *rhl* QS system consists of the signal synthase RhlI, which generates N-butanoyl-homoserine lactone (C4-HSL), and the signal receptor RhlR, which induces gene expression, when complexed with C4-HSL. The two QS systems are arranged in a hierarchical fashion such as the *las* system activates the *rhl* system (Schuster and Greenberg 2006). It has been shown that *P. aeruginosa* employs QS in the regulation of genes encoding various virulence factors. These are mainly secreted components including elastase, alkaline protease, rhamnolipids, phenazines (pyocyanin), cyanide, lectins, chitinases and numerous proteins with unknown functions (Rasmussen and Givskov 2006). The *Pseudomonas las* system mainly induces the production of elastases (Las B), protease (Las A), exotoxins and development of biofilms, whereas *rhl* induces the production of elastase, proteases, rhamnolipid, pyocyanin and siderophores (Ishida *et al.* 2007; Rutherford and Bassler 2012). There is a third QS signalling molecule in *P. aeruginosa* termed as *Pseudomonas* quinolone signal (PQS), which is also involved in the pyocyanin synthesis (Jimenez *et al.* 2012). Pyocyanin, which is a

redox-active, blue pigment phenazine, toxic to prokaryotic and eukaryotic cells, is one of the most important QS-controlled virulence factors produced by *P. aeruginosa* (Jimenez *et al.* 2012). By interfering with a wide spectrum of cellular functions in host cells such as electron transport, cellular respiration, energy metabolism, gene expression, ciliary function, epidermal cell growth and innate immune mechanisms, pyocyanin contributes to chronic respiratory infections and sepsis (Lau *et al.* 2004; Rada and Leto 2013). Another highly toxic virulence factor secreted by *P. aeruginosa* is the metalloprotease elastase, also known as Las B, which causes tissue damage and invasion, by degradation of elastin, fibrin and collagen, inactivation of the immune system components, and acts intracellularly to initiate bacterial biofilm growth (van Delden and Iglewski 1998; Cathcart *et al.* 2011).

Gram-positive bacteria regulate the QS-induced gene expression through oligopeptides, which are secreted into the environment. These small extracellular peptides operate through a 2-component signalling system. Among the Gram-positive bacteria, *Bacillus subtilis* have at least 4 groups to communicate. The variation exists in the 4 groups with respect to ComX (an extracellular pheromone) and sensor domain position of ComP (histidine kinase). Similarly, the *S. aureus* Agr system is also responsible for their segregation into 4 distinct groups. The uniqueness of the system is maintained independently in each of them (Kalia 2013).

QS may also play a role in food spoilage. Several proteolytic, lipolytic, chitinolytic and pectinolytic activities, associated with the deterioration of foods, are regulated

by QS (Bai and Rai 2011). AHLs have been detected in a variety of different spoiled commercial food products, such as cold-smoked salmon, fish fillet, minced fish, turkey meat, vacuum-packed beef, and bean sprouts, and many Gram-negative bacteria involved in food spoilage are capable of producing AHL (Rasch *et al.* 2005). The activity of *Pseudomonas* spp. growing in fruits and vegetables causes enzymatic browning, off-tastes, off-odours, and/or texture breakdown resulting in their spoilage (Bai and Rai 2011). The spoilage of fresh produce occurs, when high bacterial populations are reached, therefore, AHL-mediated QS systems could regulate the productions of bacterial enzymes associated with the spoilage of fresh products (Medina-Martinez and Santana 2012). The discovery that QS is involved in the control of biofilm formation (De Kievit 2009) and pathogenesis revealed highly attractive targets for the development of novel efficient methods and strategies in decontamination procedures.

To date, mainly naturally occurring substances have been described in the literature for their ability to inhibit bacterial QS (Adonizio *et al.* 2006; Khan *et al.* 2009; Cady *et al.* 2012; Majik *et al.* 2013). This indicates a need to examine and expand antimicrobial strategies targeting not only structural components of biofilms as well as inactivation of bacterial cells within biofilm complexes but also specifically inhibiting virulence factors so that an improved outcome of microbial biofilm inactivation and control of microbial infection are achieved. Therefore, it was of a great research interest to investigate whether novel plasma decontamination technology is capable to specifically interrupt QS system and inhibit formation of bacterial biofilm.

1.5. Sources of contamination of fresh produce

Microbial contamination can occur during any of the steps between the farm and consumer including production, harvest, processing, wholesale storage, transportation or retailing and handling in the home. This contamination can arise from environmental, animal or human sources (Olaimat and Holley 2012). The detection of contamination points is critical, in order to improve control measures towards reducing contamination at the source (Harris *et al.* 2003). Potential pre-harvest contamination may occur through soil, irrigation water, inadequately composted manure, air (dust), insects, wild and domestic animals, human handling, water for other uses (e.g., pesticides, foliar treatments, growth hormones) (Harris *et al.* 2003). The practice of animal grazing may result in the introduction of enteric bacteria in feces. Improperly composed manure, which is used as a fertilizer or as an amendment in irrigation water, can contaminate fruits and vegetables (Buck *et al.* 2003). Soil is a natural environment for variety of human pathogens, including those transferred with animal waste, where *E. coli* O157, *L. monocytogenes* and *Salmonella* can survive for long periods (7 to 25 weeks), depending on the soil type, moisture level, temperature and source of contamination (Olaimat and Holley 2012). Harvesting and post-harvest processing also influence the microbiological safety of fresh produce. Post-harvest sources of contamination include feces, human handling, harvesting equipment, transport containers, wild and domestic animals, insects, dust, rinse water, ice, transport vehicles, and processing equipment (Buck *et al.* 2003). Processing through mechanical contact, immersion in water, and cutting or slicing of fresh produce can result in enhanced bacterial

growth (Olaimat and Holley 2012), because once the vegetable or fruit is cut, the nutrients in the juices are becoming available to pathogens (Lynch *et al.* 2009). Lehto *et al.* (2011) demonstrated that the highest levels of total aerobic bacteria, yeasts, *Enterobacteriaceae* were detected on processing equipment, such as cutters, peeling machines, etc. as well as on packaging surfaces. During postharvest washing procedures of fresh produce bacterial pathogens can spread from contaminated to uninoculated produce (Carrasco *et al.* 2012). Personal hygiene of farm workers is also involved in cross-contamination of pathogenic bacteria to fresh produce (Olaimat and Holley 2012). In transport, conditions such as unclean floors and walls of the transport vehicle and unclean containers can contribute to contamination with pathogens (Lehto *et al.* 2011).

Due to the various factors that can influence microbiological quality of fresh produce, implementation of additional efficient decontamination steps within production chain are required in order to ensure microbiological safety of prepackaged, ready to eat fruit and vegetables.

1.6. Current trends in decontamination of fresh produce

Traditional thermal sterilisation of foods has been employed for many years for the inactivation of microorganisms and extension of products shelf life. However, undesirable alteration of sensorial and nutritional attributes narrow thermal processing applications (Awuah *et al.* 2007). To obtain maximum nutritional benefits from consumption, fresh fruits and vegetables are eaten raw or minimally processed. Minimally processed fruits and vegetables are commonly defined as any fruit and vegetable that has been subjected to different processing steps, such as

peeling, trimming, cutting, washing, rinsing, etc., to obtain a 100% edible product that is bagged or prepacked and maintained under refrigerated conditions during storage (Gil and Allende 2012). Minimal processing can make produce highly perishable through mechanical injuries of tissue, accelerating deterioration during transportation and storage, thus reducing produce shelf life. Besides changes in sensory quality, minimal processing may induce chemical and enzymatic changes (Siddiqui *et al.* 2011). Additionally, processing steps can represent a source of spoilage and pathogenic contamination, which is mainly due to the direct contact of the produce with contaminated product, equipment, water or personnel (Gil and Allende 2012). Minimally processed fruits and vegetables are obtained by refrigeration, chemical preservation (ascorbic acid and calcium salts), addition of bio-preservatives, mild heat treatments, microwave processing, reduction of water activity, ionizing irradiation, the use of disinfectants (electrolyzed water treatment, chlorination, hydrogen peroxide), high hydrolytic pressure technology, high intensity pulsed electric field, pulsed light, ozone technology, vacuum/hypobaric packaging and hurdle technologies. Edible coatings (multilayer coating, osmotic membrane coating) are also being used in minimally processed fruits and vegetable to maintain quality and to extend shelf life of minimally processed products (Siddiqui *et al.* 2011). These methods provide good results in a number of cases, however, sometimes they are expensive, there is a lack of effectiveness, or they are too slow. Some methods, moreover, adversely alter food properties such as color, taste and smell, or damage their structure. Other adverse effects sometimes occur, namely a decrease of the valuable nutritive content, or even the formation of toxic

by-products (Scholtz *et al.* 2015). Examples of some of the commonly used disinfectants and some with a mechanism of action similar to atmospheric cold plasma are described in the following sections.

1.6.1. Chlorine

Chlorinated water is inexpensive and easy to use (Delaquis and Bach 2012). The recommended concentrations range from 50 - 200 ppm and contact time 1 – 2 min. Although chlorine is ineffective for elimination of pathogens (common bacterial reductions 1 - 3 log CFU/g), it is the most widely used sanitizing agent to prevent potential cross contamination during washing (Olaimat and Holley 2012). The efficacy of chlorine washing has been studied over the past decades. For example, washing treatment with 20 mg/l chlorine solution for 5 minutes was not effective against *E. coli* O157:H7 proliferating on the cut edges of iceberg lettuce (Seo and Frank 1999). Dipping or convenient at the retail sites spray applications of 200 – 2,000 ppm chlorine showed only 2.3 log reduction of bacterial population of *E. coli*, *Salmonella*, and *L. monocytogenes* inoculated onto apples, tomatoes and lettuce leaves (Beuchat 1998). Washing treatments with sodium hypochlorite and chlorine dioxide, which is considered as an alternative to sodium hypochlorite sanitation, were ineffective against *E. coli* cells that were located in tissue stomata (Lopez-Galvez *et al.* 2010). Moreover, chlorine washings are ineffective against bacterial biofilm that are more resistant to detachment and inactivation. Beside the low inactivation levels with chlorinated washing, another factor of public health concern is environmental chlorine emissions in combination with toxicity of chlorinated by-products formed in contact with foods. This has led to consideration

of non-chlorinated alternatives, notably, organic acids, hydrogen peroxide and ozone (Delaquis and Bach 2012).

1.6.2. Organic acids

Organic acids have a long history of being utilized as food additives and preservatives for preventing food deterioration (Back *et al.* 2009). Generally Recognized as Safe (GRAS), organic acids (citric acid, propionic acid, tartaric acid, lactic acid, acetic acid and malic acid) represent a group of antimicrobial agents which action is mainly due to the reduction in the environmental pH (Olmez and Kretzschmar 2009). It has been assumed that the antibacterial mechanism for most of the organic acids is based on the diffusion of the undissociated form through the lipid membrane of the bacterial cell (Peláez *et al.* 2012), which in turn has the ability to disintegrate cell main functions (Back *et al.* 2009). Enzymatic activity, protein and nucleic acids may also be adversely impaired by the presence of organic acids (Peláez *et al.* 2012; Mani-López *et al.* 2012). It has been shown that the degree of microbial inactivation efficacy of organic acids is the function of the acid pH, concentration and time of acid exposure. For example, Choi *et al.* (2012) studied antimicrobial activity of aerosolized malic acid against *L. monocytogenes*, *S. Typhimurium*, and *E. coli* O157:H7 on spinach and lettuce. Treatment with highest concentration of malic acid (2%) for longest duration (100 min) was the most effective in the reduction of three pathogens. Maximum reduction levels of *L. monocytogenes*, *S. Typhimurium*, and *E. coli* O157:H7 on spinach and lettuce achieved in this study were 3.35, 4.10, 3.67, and 3.85, 5.02, 3.35 log₁₀ CFU/g, respectively. Sagonga *et al.* (2011) used malic acid,

lactic acid and citric acid to reduce bacterial population of *E. coli* O157:H7, *S. Typhimurium*, and *L. monocytogenes* on lettuce samples. Reduction levels of the three pathogens increased with the increase of organic acid concentration from 0.3 to 2.0% and with the decrease of pH from 2.54 to 2.11. The type of organic acid did not significantly influence the reduction of the three pathogens. Highest reduction of the three pathogens at 2.0% organic acids for 5 min was 1.60 log CFU/g. Moreover, in this study combined treatment of ultrasound and organic acid for 5 min achieved only an additional 1.0 log reduction of the three pathogens compared to organic acid treatment alone. Similarly, Huang and Chen (2011) investigated bactericidal effect of lactic acid, citric acid, malic acid, tartaric acid at different concentrations in combination with mild heat on baby spinach leaves dip-inoculated with *E. coli* O157:H7. Application of lactic acid 1% at 40°C for 5 min was the most effective treatment achieving a 2.7 log bacterial reduction, which was significantly higher than conventional chlorine washing.

The antimicrobial activity of organic acids changes with the exposure times, pH and concentrations utilised. Time of application needed to achieve significant reduction in microbial load can range between 5 and 15 min, which is not relevant to the food industry (Olmez and Kretzschmar 2009). Moreover, high concentrations of organic acids can adversely affect the quality of leafy vegetables. Due to the characteristic flavour of the organic acids, they may have a negative effect on the sensory quality of the product. It must also be taken into consideration that the use of organic acids for disinfection purposes in the fresh-cut industry

would have an impact on the wastewater quality, characterized by high COD and BOD values in the wastewater (Olmez and Kretzschmar 2009).

1.6.3. Hydrogen peroxide

Hydrogen peroxide possesses a bacteriostatic and a bactericidal activity due to its strong oxidizing power and capacity to generate other cytotoxic oxidizing species such as hydroxyl radicals, superoxide and singlet oxygen (FDA 2009). It is effective against a wide spectrum of bacteria, yeast, moulds, viruses and spore-forming organisms by destruction of proteins, DNA and cellular membranes of microbial cells and removing the protein from the coat of the bacterial spore. For use in food products, H₂O₂ has GRAS status. It has found application in disinfection of vegetables, fruits, and poultry, but its use is limited for disinfection of milk, dried egg, starch, tea and wine to the concentration range of 0.04–1.25% (Demirkol *et al.* 2008; Olmez and Kretzschmar 2009). Various factors have been reported to greatly influence the antimicrobial activity of H₂O₂, such as sanitizer concentration, pH and temperature, contact time and produce surface. Raffellini *et al.* (2008) studied the influence of concentration, environmental pH and treatment time on the H₂O₂ antimicrobial activity against *E. coli*. They reported that lowest studied concentration of H₂O₂ (0.75% w/v) and longer treatment durations (7.2 min) were required to achieve 5 log bacterial reduction. Later, the same research group showed clear dependence of inactivation kinetics of *E. coli* on the temperature beside the earlier screened hydrogen peroxide concentration and pH. In general, more *E. coli* cells were inactivated as the temperature exposure and agent concentration increased (50°C, 3% w/v) and the pH decreased (Raffellini *et*

al. 2011). Lin *et al.* (2002) conducted the study on lettuce leaves inoculated with pathogenic bacteria. The 60 s treatment of samples with H₂O₂ (2%) at 50°C resulted in a maximum of 4 log reduction of *E. coli* O157:H7 and *Salmonella* Enteritidis, whereas a 3 log reduction of *L. monocytogenes* was obtained. Gopal *et al.* (2010) reported significant reduction of *Pseudomonas* spp. after immersion of inoculated lettuce for 2 minutes into H₂O₂ (0.4 ppm). However, yeasts were capable to recover after 2 days of storage at 12°C and maintained high counts (7 log) throughout the 7 days of storage period.

Although considerable reductions of bacterial population can be achieved by hydrogen peroxide treatment, this method has a drawback of being phytotoxic against some products, interfering, therefore, with the overall quality of the product when applied at high concentrations (4–5%) (Parish *et al.* 2003; Olmez and Kretzschmar 2009). Hydrogen peroxide was also shown to damage plant cells isolated from tomato, cucumber, and soybean through oxidation of cell wall polysaccharides (Demirkol *et al.* 2008). Higher overall quality was maintained and higher reductions in the microbial counts were achieved when applied at higher temperatures such as 50–60°C and decreased pH (Olmez and Kretzschmar 2009).

1.6.4. Ozone

Ozone is a pale blue gas with a pungent characteristics odour. Its oxidant-reduction potential is much higher than that of chlorine, acids and hydrogen peroxide. It has gained GRAS status in 1997, and its use has been approved in Europe and in the US for treatment, storage, and processing of foods, including meat and poultry, as well as raw agricultural commodities. Ozone in both gaseous and aqueous states is

effective against a wide range of pathogenic microorganisms including bacteria, yeasts, moulds and viruses (Olmez 2012). The stability of the ozone in water is inversely proportional with temperatures, the presence of organic substances with high ozone demand and pH (Khadre *et al.* 2001). The half-life of ozone in water at room temperature is 20 – 30 min and decomposition products are free radicals species (hydroperoxyl, hydroxyl, superoxide anions), which are responsible for the oxidising power of aqueous ozone (Olmez 2012). Treatment with ozone of fruits and vegetables has been widely studied. Recent study suggested that over the 2 log reduction in the microbial population can be obtained on dried oregano by gaseous ozone treatments with an acceptable taste, flavour and appearance (Torlak *et al.* 2013). Alexopoulos *et al.* (2013) analysed fresh-cut lettuce and green bell peppers for reduction of their surface microflora by ozonated water. The most effective treatment was when vegetables were dipped in continuously ozonated water (0.5 mg/L), leading to 3.5 log of microbial reductions after 30 min of exposure, which is higher than after chlorination. Fan *et al.* (2012) reported 2 to 3 log reductions of *E. coli* and *Salmonella* inoculated on tomatoes after 2 – 3 min of ozonation. In general, the efficacy of ozone treatment will depend on many factors, including type of vegetable, microorganism, initial inoculum level, ozone delivery method, temperature and organic material present (Olmez 2012). In terms of bacterial inactivation, ozone destroys microorganisms through widespread oxidation of internal cellular components, causing rapid cell death. The major mechanisms involve oxidation of sulfhydryl groups and amino acids of enzymes, peptides and proteins to shorter peptides; oxidation of unsaturated fatty acids to acid peroxide;

degradation of cell envelope lipids resulting in leakage of cellular components; increase in cell permeability protein disruption and damage of nucleic acid resulting in cell lysis (Guzel-Seydim *et al.* 2004). Additionally ozone has elevated diffusion capabilities that enable its rapid diffusion through biological cell membranes (Alexopoulos *et al.* 2013).

Ozone is a potent sanitizer that leaves no hazardous residues on food or food-contact surfaces and is the most likely alternative to chlorine and hydrogen peroxide in food applications. Ozone treatment requires no heat, thus, saves energy, and reduces water consumption (Khadre *et al.* 2001). Another advantage of this treatment is that when used at the appropriate levels, ozone does not interfere with sensory and nutritional quality of fresh and minimally processed produce (Olmez 2012).

Other non-thermal, non-aqueous sterilisation methods include high pressure processing, ionising radiation, ultrasonication, pulsed light, and hurdle technologies such as MAP, active packaging, ozonation and enzymes in conjunction with other technologies in synergy that are used to preserve the foods (Morris *et al.* 2007; Niemira and Sites 2008). Ionising radiation is one of the most effective non-thermal sterilisation method utilised against such spoilage and pathogenic bacteria as *Salmonella*, *E. coli* O157:H7, *L. monocytogenes* and *Campylobacter jejuni*, which leads to fragmentation of bacterial DNA. However, during irradiation adverse sensory quality changes, such as lipid oxidation, off-flavour may affect overall product quality and acceptability by consumers. Other drawbacks of the above listed techniques are low energy efficiency, some

alterations of food quality, high initial costs of equipment, required safety measurements and trained personnel (Morris *et al.* 2007; Yun *et al.* 2010; Kim *et al.* 2011). Moreover, adhesion of pathogens to surfaces, internalization of pathogens and biofilm formation limits the usefulness of conventional processing and chemical sanitizing methods in preventing transmission from contaminated produce. The disadvantages of the methods initiated a search for new or terminal control decontamination approaches, which could prevent contamination during processing while maintaining produce quality characteristics and extending produce shelf life.

1.7. Atmospheric cold plasma technology

Plasma is often referred to as a fourth state of matter as it shares properties similar to both those of gases and liquids. A neutral gas can be converted to plasma by the application of energy in several forms, including thermal, electric or magnetic fields, and radio or microwave frequencies (Wan *et al.* 2009). Application of strong electromagnetic field to a neutral gas that induces ionisation is the most commonly used method of generating cold plasma (Banu *et al.* 2012). The constant supply of energy to the feed gas will cause generation of photons, electrons, positively and negatively charged ions, atoms, free radicals and excited or non-excited molecules (Moreau *et al.* 2008). Electrons and ions are produced in the gas phase when electrons or photons with sufficient energy collide with neutral atoms and molecules in the feed gas (Banu *et al.* 2012).

According to the generation conditions, plasma can be classified into two types: thermal plasma and non-thermal or cold plasma. Heating the gas may ionise its

molecules or atoms (reduce or increase the number of electrons in them), thus turning it into plasma (Banu *et al.* 2012). Within thermal plasma, all species are characterised by thermodynamic equilibrium and are extremely reactive (Moreau *et al.* 2008; Niemira 2012a). The temperature of the thermal plasma may reach the values of several thousands of Kelvins (Scholtz *et al.* 2015). In contrast, atmospheric cold plasma (ACP) has a non-uniform distribution of energy among the constituent species, i.e. characterised by non-equilibrium, and various plasma-chemical reactions are induced (Niemira 2012a; Scholtz *et al.* 2015). According to Scholtz *et al.* (2015), the majority of reactive species produced by the commonly used plasma sources are following:

- Electronically and vibrationally excited oxygen O₂ and nitrogen N₂,
- Active form of oxygen molecules and atoms, i.e. reactive oxygen species (ROS), such as atomic oxygen O, singlet oxygen ¹O₂, superoxide anion O₂⁻ and ozone O₃,
- Reactive nitrogen species (RNS), such as atomic nitrogen N, excited nitrogen N₂(A), nitric oxide NO•,
- If humidity is present H₂O⁺, OH⁻ anion, OH• radical or H₂O₂ is also generated.

ACP may be obtained by a diversity of electrical discharges, such as corona discharge, micro hollow cathode discharge, gliding arc discharge, one atmospheric uniform glow discharge, dielectric barrier discharge, atmospheric pressure plasma jet and plasma needle. The type of plasma source will determine technological application, the composition and abundance of chemical species produced (Nehra

et al. 2008; Scholtz *et al.* 2015). The commonly used forms of ACP and of our most interest in terms of a high potential in industrial applications are dielectric barrier discharge and plasma jets.

1.7.1. Dielectric barrier discharge ACP

The dielectric barrier discharge (DBD) was first utilised in Europe 100 years ago for ozone production for the treatment of drinking water. Since then, the industrial applications of the DBD ACP systems grew rapidly (Chirokov *et al.* 2005). The DBD device typically consists of two plane-parallel metal electrodes, and at least one of them is covered by dielectric barrier (Fig. 1). The dielectric barrier can be made from glass, quartz, ceramics or polymer, and play an important part by (i) limiting the discharge current and avoiding the arc transition that enables to work in a continuous mode, and (ii) distributing randomly streamers and ensuring a homogenous treatment (Chirokov *et al.* 2005; Tendero *et al.* 2006). Properties of plasma are mainly attributed to distance between the electrodes, gas composition, voltage levels and frequency excitation (Bardos and Barankova 2010). Depending on these parameters, plasma can be either filamentary or glow (Tendero *et al.* 2006). The filaments or streamers make plasma strongly non-uniform and are not desirable for surface treatment, since hot streamer arcs can damage surfaces of soft materials. However, several approaches have been identified to be useful for avoiding streamers and making plasma more uniform. These include the use of a high frequency (microwave discharge), specific dielectric barrier arrangements and material, high gas flow rates, suitable gases, distance between electrodes and treated objects and a combination of these methods (Bardos and Barankova 2010).

The major advantages of the DBD include the ease of the discharge ignition, manifold adaptability due to the different electrode geometries and treatment of objects inside sealed packaging material whereby the DBD is especially interesting for industrial applications.

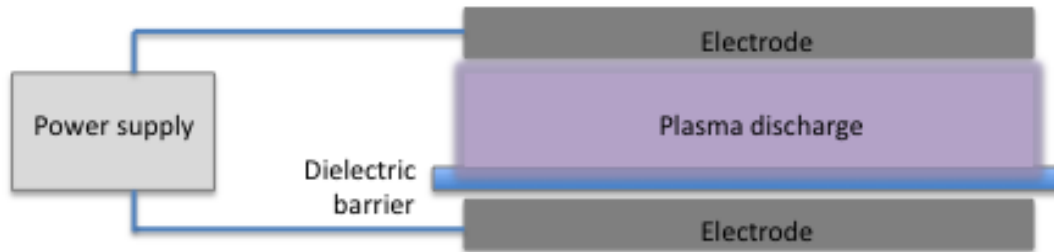

Figure 2: Schematic diagram of DBD system.

1.7.2. ACP jets

Since 1990s, an interest in plasma jets for bacterial inactivation has been increased, which is another type of discharge capable of generating ACP at atmospheric pressure (Morent and De Geyter 2011). Designs of atmospheric plasma jets widely vary among the research studies (Chiang *et al.* 2010; Lee *et al.* 2011; Chen *et al.* 2012; Frohling *et al.* 2012a,b; Niemira 2012b; Suhem *et al.* 2013). The design of several plasma jets has been reviewed in detail by Uhm and Hong (2011). Generally, these plasma sources typically operated in the radio frequency range, e.g. at 13.56 MHz or 27.12 MHz and voltages of about some 100 V up to kV, depending on the process gas and gap between electrodes. Generally, jets consist of two electrodes in different arrangements, which include coaxial and special ring setups, as well as single electrode configurations with a virtual grounded electrode. The distance of the electrodes is in the range of mm, whereas the exposure distance

to the contaminated surface is in the cm range. The process gases are noble gases like helium or argon with variable gas flow rates. In general, the process temperature is based on the high gas flow and low power consumption, but with special arrangements (electrical input signals, e.g. burst mode) the temperature can be decreased down to room temperature (Ehlbeck *et al.* 2011).

Atmospheric pressure plasma jets are very practical due to their small plasma dimensions, thus, can be employed to treat small-sized objects as well as for treatment of narrow gaps with micro structured cavities or capillaries. However, by moving the jet over the selected area or by applying the multiple nozzles, plasma jets can be utilised for treatment of larger areas (Morent and De Geyter 2011). Another advantage of plasma jets for microbial inactivation is the high etch rate. On the other side, the application of jets becomes limited for treatment of complex 3-dimensional objects (Ehlbeck *et al.* 2011).

1.8. Applications of ACP

Atmospheric cold plasmas present considerable interest for a wide range of environmental, biomedical and industrial application, such as surface modification (e.g. etching), functionalization (e.g. hydrophilization, hydrophobization, adhesability, printability), air pollution control (e.g. diesel), wastewater cleaning (textile industry), medical applications and bacterial decontamination and sterilisation (Conrads and Schmidt 2000).

1.8.1. Surface processing

Surface processing and coating by ACPs are among the most intensively studied technologies, which include: surface pre-treatment, cleaning and activation;

deposition of films; and post-treatment of coated surfaces in order to change the chemical composition or crystallinity of the coating (Bardos and Barankova 2010). Surface cleaning consists of removing of contaminates such as oil, dust, oxides, biological and chemical agents, with application of plasma technology as an alternative to the halogenated solvents. Surface etching consists of removing material from the surface in order to create a relief. Application of plasma for coating occurs through the air plasma spray. The coating material (e.g. powder) suspended in the carrier gas, injected into the plasma jet, then the particles are accelerated and deposited on the surface of the substrate (Tendero *et al.* 2006).

1.8.2. Air pollution

The air pollution control technologies for acid gases, volatile organic compounds, flue gases, industrial gases, which have been commercialized, are based on catalysis, incineration and adsorption methods. Established thermal methods for gas cleaning are very efficient, when the concentration of organic compounds is high enough to allow an auto-thermal regime. However, non-thermal plasma techniques based on electron beams and corona discharges become significant due to advantages such as lower cost, higher removal efficiency, and smaller space volume (Urashima and Chang 2000; Roland *et al.* 2002). Volatile organic compounds are an important category of air pollutants. Recent data suggests that 260,000 tonnes of volatile organic compounds per year emitted in Europe from food processing industries such as baking, vegetable oil extraction, solid fat processing, animal rendering, fish meal processing, coffee production and sugar beet processing, and drink manufacturing sectors. Vandenbroucke *et al.* (2011) and

Preis *et al.* (2013) reviewed in detail the main classes, sources of volatile organic compounds, their impacts and recent achievements and the current status of ACP technology for the abatement of volatile organic compounds.

1.8.3. Plasma in medicine

Plasma technology is an innovative and emerging field, which is intensively researched for a range of different medical applications. Von Woedtke *et al.* (2013) classified plasma for medical application according to two general principles: indirect use of plasma to treat surfaces, materials or devices for medical applications, and application of physical plasma on or within the human body. Sterilization of medical materials or devices (e.g., medical implants, catheters, or materials in blood purification systems) is the main use of indirect plasmas for medical purposes; whereas physical plasmas are under intense study for applications in wound healing (Kramer *et al.* 2013; Wu *et al.* 2013) blood coagulation and skin regeneration (Emmert *et al.* 2013), dentistry (Pan *et al.* 2013) and apoptosis of cancer cells (Kim *et al.* 2010).

Modifications of biomaterial surfaces by plasma include changes of surface morphology and texture, increase of surface wettability to increase and optimize or inhibit adhesion of living cells or organic matter like proteins, bacteria or cells is the other application of plasma in medicine. Plasma treatment of surfaces is the use of plasmas for sterilization or decontamination of materials or devices for medical purposes, and other plasma applications reviewed by von Woedtke *et al.* (2013).

1.8.4. Wastewater treatment

The degradation of organic compounds from contaminated industrial wastewater using ACP has been intensively investigated. The wastewater from paper and textile industries is highly contaminated due to the presence of dyes (Reddy *et al.* 2013). More than 700,000 tons of dyes and pigments are produced over the world. Some of them are discharged as industrial effluent, which make the water inhibitory to aquatic life (Zhang *et al.* 2009). Treatment methods for textile effluent encompass biological, physical, chemical methods and the combinations of these methods. Biological treatments are economically feasible but not effective and cannot be used to treat with the toxic pollutants. Thermal destruction of chemical at high temperature however is not economical. Chemical treatment with the usage of oxidants such as chlorine, hydrogen peroxide can overcome these disadvantages; however, it does not always result in the total degradation of the contaminants (Zhang *et al.* 2009; Reddy *et al.* 2013). Oxidation processes have a specific advantage over conventional treatments and may eliminate the problems associated with bio-resistant organic compounds. ACP technique was not applied until now for the removal of water pollutants on a large scale, but due to generation of highly reactive oxygen and nitrogen species under ambient conditions, it can be potential alternative treatment for the degradation of dyes in liquid phase (Reddy *et al.* 2013). Methylene blue ($C_{16}H_{18}N_3SCl$) is a model basic aniline dye employed by textile industry for variety of purposes, such as coloring paper, dyeing cotton and wools, etc. (Wong *et al.* 2013). Ozone readily reacts with methylene blue dye (MB). Because ozone is considered as one of the long-lived plasma reactive

species, it is expected that ACP treatment could be a potential for degradation of such dye. Recently, Huang *et al.* (2010) characterised MB degradation pathway due to the plasma treatment. During the degradation chlorine is ionised first, then nitrogen-methyl group is broken, following by nitrogen - methyl bond disruption. The presence of plasma generated radical species in the methylene blue solution results in oxidation of organic molecular structures until they are finally transformed into inorganic ions, such as carbon dioxide, water, chlorine, sulphates and nitrates ions (Huang *et al.* 2010). Considering the fact that ozone is very effective in decomposition of textile effluents, it may be possible, using MB as a model dye indicator, to establish a relationship between bacterial reductions and MB degradation.

1.8.5. ACP as a food processing technology

Raw fruits and vegetables can become contaminated while growing or during harvesting, postharvest processing, storage or distribution. How bacteria attach and the strength of attachment has not been well understood, but once attached to the surface of fresh produce it is difficult to remove the pathogens by washing (Berger *et al.* 2010; Warning and Datta 2013). Conventional postharvest washing and sanitising treatments are not highly effective for produce, often resulting in less than 2 log unit reductions of pathogens (Niemira 2012a). Moreover, some low pH based preservation techniques may contribute to the bacterial adaption to acidic environment subsequently inducing their homologous resistance and cross protection mechanisms. In addition, disinfection can become less effective against

bacterial biofilms associated with rough surfaces of produce and against bacterial cells internalised in produce tissue.

ACP technology is a relatively new approach aiming to improve microbiological safety in conjunction with maintenance of sensory attributes of the treated foods. In recent years, ACP treatments of fresh fruits, vegetables and other products have been the subject of much research, which demonstrated that ACP may offer a good alternative to conventional methods within food production settings. A key process advantage of ACP application is the minimal water usage, inactivation of all types of microorganisms, non-toxic nature, reduction of operating costs if an atmospheric air as a working gas is used and the development of large-scale systems for continuous treatment of different produce commodities. However, apart from issues associated with water mediated decontamination, it is likely that many of the features associated with minimal processing and physiological characteristics of produce that impact on traditional decontamination, may also interact with the optimum application of ACP. The design of ACP systems, including producer gas composition, gas flow rate, electrode configuration, voltage levels, varies widely among research studies, acting as determinants for the general inactivation effects of treatment. Factors such as the type of bacteria, cell concentration and substrate or treated media may also influence plasma treatment decontamination effects. For example, Fernandez *et al.* (2013) demonstrated that the efficacy of nitrogen plasma jet to reduce *Salmonella* was influenced by substrate surface features. Gliding arc discharge plasma generated from air was more effective at the higher flow rates against bacteria inoculated on apples

(Niemira and Sites 2008). Yu *et al.* (2006) found that inactivation efficacy of plasma treatment depended on cell surface concentration and cells growth phase. Higher voltage, excitation frequency and presence of oxygen in the gas composition for generation of plasma resulted in higher inactivation rates of *Listeria innocua* on chicken muscle and skin (Noriega *et al.* 2011). The distance from plasma emitter as well as bacterial isolate and gas composition had an effect on antimicrobial efficacy of plasma system studied by Niemira (2012b) with greatest reductions of *E. coli* population inoculated on almonds achieved after treatment at higher distance from plasma emitter. The increased antimicrobial effect of ACP utilised at higher distances is possibly due to recombined plasma reactive species. The use of indirect plasma in conjunction with utilisation of closed chambers for decontamination of meat produce have been highlighted in recent studies conducted by Rod *et al.* (2012) and Frohling *et al.* (2012b). However, there are limited numbers of reports based on plasma decontamination of perishable fresh fruits and vegetables. Recent research studying decontamination effects of ACP against bacteria inoculated on fresh produce are summarised in Table 1. These data demonstrate high variability in the maximal bacterial inactivation achieved by ACP depending on the bacterial strain, produce utilized, treatment conditions and equipment used. An absence of standardised method with regards to bacterial strains, initial microbial load, type of produce and produce load, for evaluation of antimicrobial properties of decontamination techniques complicates the comparison between reduction achieved by utilisation of various plasma systems and general conclusions about overall ACP antimicrobial efficacy

cannot be made. However, summarised results could be useful for future studies on designing the optimal plasma system suitable for the application in food production with aims to improve microbiological safety and extend the produce shelf life.

Table 1: Published research on the inactivation of bacteria on fresh produce by ACP treatment.

ACP source	Gas	Bacteria	Produce	Maximal log reduction	Reference
One atmosphere uniform glow discharge plasma	Air	<i>E. coli</i> , <i>Salmonella</i> , <i>Listeria</i>	Apples, cantaloupe, lettuce	<i>E. coli</i> >2, <i>Salmonella</i> >3, <i>Listeria</i> >5	Critzer <i>et al.</i> 2007
Gliding arc discharge	Air	<i>E. coli</i> , <i>Salmonella</i> <i>Stanley</i>	Apples	<i>E. coli</i> ~3.6, <i>Salmonella</i> ~3.7	Niemira and Sites 2008
DBD	Air, oxygen	<i>E. coli</i>	Spinach	<i>E. coli</i> ~5	Klockow and Keener 2009
Plasma micro jet	Air	<i>Salmonella</i> spp.	Carrots, cucumbers, pears	N/A	Wang <i>et al.</i> 2012
Plasma jet	Argon	<i>E. coli</i>	Corn salad leaves	<i>E. coli</i> ~3.6	Baier <i>et al.</i> 2013
Needle array plasma	Argon	<i>E. coli</i>	Lettuce, carrots, tomatoes	<i>E. coli</i> ~1.7	Bermúdez-Aguirre <i>et al.</i> 2013
Plasma jet	Nitrogen	<i>Salmonella</i>	Lettuce, strawberry, potato	<i>Salmonella</i> ~2.7	Fernandez <i>et al.</i> 2013
Radio frequency plasma/ chamber	Oxygen	<i>Salmonella</i>	Spinach, lettuce, tomato, potato	<i>Salmonella</i> <3	Zhang <i>et al.</i> 2013
Plasma jet, DBD	Argon/oxygen mix	<i>E. coli</i>	Corn salad, cucumber, apples,	<i>E. coli</i> ~4.7	Baier <i>et al.</i> 2014

tomato					
Long wavelength UV light Photoplasma, Model: Induct, ID 60/chamber	Air	<i>Aeromonas hydrophila</i>	Lettuce	<i>Aeromonas hydrophila</i> ~5	Jahid <i>et al.</i> 2014a
Microwave-powered ACP/chamber	Nitrogen, Nitrogen-Oxygen mix, Helium, Helium-Oxygen mix	<i>Aspergillus flavus</i> , <i>B. cereus</i> spores, Background microflora	Red pepper powder	<i>Aspergillus flavus</i> ~2.5 <i>Bacillus cereus</i> ~3.4, Background microflora ~1	Kim <i>et al.</i> 2014
Long wavelength UV light Photoplasma, Model: Induct, ID 60/chamber	Air	<i>Listeria</i>	Lettuces, cabbages	<i>Listeria</i> ~4	Srey <i>et al.</i> 2014b
Plasma jet	Air	Background microflora	Blueberries	Background microflora ~2	Lacombe <i>et al.</i> 2015
Long wavelength UV light Photoplasma, Model: Induct, ID 60/chamber	Air	<i>Salmonella</i> Background microflora	Lettuce	<i>Salmonella</i> ~3.7 Background microflora ~4.1	Jahid <i>et al.</i> 2015
Radio frequency plasma jet	Argon	<i>Salmonella</i> , <i>B. subtilis</i> spores, <i>B. atrophaeus</i> spores	Whole black pepper	<i>Salmonella</i> ~4.1, <i>B. subtilis</i> spores ~2.4, <i>B. atrophaeus</i> spores ~2.8	Hertwig <i>et al.</i> 2015
Plasma jet	Argon	<i>E. coli</i> O157:H7 <i>E. coli</i> O104:H4	Corn salad leaves	<i>E. coli</i> O157:H7 ~3.3 <i>E. coli</i> O104:H4 ~3.3	Baier <i>et al.</i> 2015a
Microwave	Air	<i>E. coli</i> ,	Apples,	<i>E. coli</i> ~6	Baier <i>et al.</i>

plasma torch	Background microflora	cucumbers, tomatoes, carrots	Background microflora ~5.2	2015b
--------------	--------------------------	------------------------------------	----------------------------------	-------

Furthermore, to date much research has been done towards investigation of the efficacy of plasma for eradication of bacterial biofilms associated with food processing as well as health care settings (Cotter *et al.* 2011; Traba and Liang 2011; Alkawareek *et al.* 2012a; Alkawareek *et al.* 2012b; Maisch *et al.* 2012; Sun *et al.* 2012; Traba *et al.* 2013). However, there are limited investigations on the use of high voltage in-package ACP treatment for elimination of biofilms on abiotic surface and biofilms associated with the surface of fresh produce, and how biofilms as a microbiological challenge may be best addressed using the system and process parameters of cold plasma.

1.9. Mechanism of action of ACP

The chemical composition of ACP is very complex, and multiple different reactive agents are expected to play a role, independently or in synergy, in inactivation of bacterial species. In general, the composition and thus the efficacy of ACP will depend on the equipment design and system's operating parameters, such as gas composition, flow rate, moisture, temperature, voltage and frequency (Dobrynin *et al.* 2009; Wan *et al.* 2009; Ehlbeck *et al.* 2011). As commonly known, air ACP is an excellent source of electrons and positive and negative ions, free radicals, stable conversion products (e.g. ozone), excited atoms and molecules, and ultraviolet radiation (UV) photons (Stoffels *et al.* 2008). The exact mechanisms of plasma mediated bacterial inactivation are not yet completely understood, but several

plasma products have been demonstrated to play a role in this process. These products include ROS, RNS, UV radiation and charged particles. Among the ROS, ozone, atomic oxygen, singlet oxygen, superoxide, peroxide, and hydroxyl radicals, are considered to be involved in bacterial inactivation process (Joshi *et al.* 2011; Alkawareek *et al.* 2012b).

Most bacteria, particularly, anaerobes are considered to be very sensitive to ROS species (Stoffels *et al.* 2008). The diffusion of oxygen species or oxygen containing radicals (nitric oxide) through bacteria cell wall causes the local damage possibly by oxidation of cytoplasmic membrane, protein and DNA strands (Gallagher *et al.* 2007). Joshi *et al.* (2011) reported that singlet oxygen and hydrogen peroxide species were responsible for membrane lipid peroxidation, as ROS scavengers significantly reduced the oxidative damage of *E. coli* DNA. Sureshkumar *et al.* (2010) demonstrated that the addition of 2% oxygen into the nitrogen gas resulted in the formation of nitric oxides, which therefore significantly enhanced the effect on the sterilization of bacteria. The presence of these reactive species was confirmed by optical emission spectroscopy.

Bombardment on the cell wall by charged particles, electrons and ions can result in breaking of chemical bonds, cause erosion through etching, formation of lesions and openings in the membranes, inducing further penetration of plasma toxic compounds inside a bacterial cell (Gallagher *et al.* 2007; Moreau *et al.* 2008). Inactivation effect through erosion is believed to be easier to achieve in Gram-negative bacteria, due to the vulnerability of the cell wall, compared with those of Gram-positive species with a thicker membrane structure (Stoffels *et al.* 2008).

Another aspect that will play a significant role in the mechanical disruption of bacterial cell membrane by ACP is the ACP mode of exposure, which has been widely classified in literature as direct and indirect (Dobrynin *et al.* 2009). Direct ACP exposure is characterised by the action of charged particles, reactive neutrals, short/longer living reactive species, electromagnetic radiation, i.e. all possible agents generated by plasma. Indirect exposure is when the sample is placed at some distance from the plasma, thereby affected by longer living reactive species, and charged particles do not largely participate in treatment as they recombine before reaching the sample (Laroussi 2009). Moreover, Fridman *et al.* (2007) in their studies highlighted the importance of charged particles generated by the direct plasma exposure and possible contribution of these species to the overall efficacy of direct plasma. Therefore, it is possible that erosion as a mechanism of action, would not be considered in cases when samples were subjected to indirect treatment.

Another mechanism that has been described in the literature is the etching effect of plasma, which is likely based on the oxidation process (Fricke *et al.* 2012). Perforations on the cell membranes caused by etching will enhance the diffusion of secondary reactive species that might be formed in the plasma discharge inside the cell. Etching, as a result of reaction between the excited atoms/molecules and radicals and organic materials will cause the bond breaking of molecules, particularly hydrocarbon compounds. This in turn will lead to the formation of molecular fragments and volatile compounds emanating from the cells, hence, causing morphological changes, such as reduction in cell size or the appearance of

deep etch channels in the cell up to complete cellular destruction. The presence of chemically reactive species, like atomic oxygen and ozone, easily react with these open bonds, which facilitates a faster etching of molecules (Ermolaeva *et al.* 2011; Fricke *et al.* 2012).

Many of these mechanisms of action of plasma on bacterial cells have been reported, however, it is important to consider the additive and synergistic effects of these species with each other's and with other plasma products like UV radiation and charged particles, in such a physically and chemically complex environment.

1.10. Objectives

Considering the research to date the objectives of this study were:

- To determine the influence of extrinsic DBD ACP critical control parameters such as treatment time, post treatment storage time, mode of ACP exposure, voltage level, processing gas composition on treatment inactivation efficacy against *E. coli* ATCC 25922.
- Using optimised DBD ACP parameters, to evaluate the efficacy of treatment against common foodborne pathogens, *E. coli*, *Salmonella* and *L. monocytogenes*, inoculated on fresh produce and against background microflora present on produce.
- To investigate antimicrobial efficacy of ACP treatment for elimination of challenge biofilms of Gram-negative and Gram-positive microorganisms grown on abiotic and biotic surfaces. Using a range of viability and metabolic activity assays to elucidate mechanisms of action of ACP on bacterial biofilms.

- To examine the effect of different time and temperature storage conditions on biofilm formation on fresh produce and bacterial internalisation into produce and any possible effects on ACP antimicrobial efficacy.
- To investigate the effect of ACP on *P. aeruginosa* QS-controlled virulence factors production such as pyocyanin, elastase (Las B) and development of biofilms.

Chapter 2: MATERIALS AND METHODS

2.1. Bacterial strains and growth conditions

The microorganisms, growth media, bacterial mode of growth, substrate or type of a system subjected to ACP treatment and type of DBD ACP system utilised are presented in Table 2. Microorganisms stock cultures were maintained at -70°C in the form of protective beads (Technical Services Consultants Ltd, UK). One protective bead of each culture was streaked onto separate tryptic soy agar (TSA, ScharlauChemie, Spain) and *E. coli* BL21 and XL10 strains were streaked onto TSA supplemented with ampicillin (100 mg/L) (Sigma Aldridge, Ireland). The plates were incubated at 37°C for 24 h and further maintained at 4°C. A single isolated colony of each culture was inoculated in tryptic soy broth with/without glucose (TSB+/-G, ScharlauChemie, Spain) and incubated at 37°C for 18 h. TSB supplemented with ampicillin was used for *E. coli* BL21 and XL10 strains. In the study of inhibition of quorum sensing (QS)-controlled virulence factors *P. aeruginosa* was inoculated in TSB (-G) and incubated for 24 h at 37°C. Unless otherwise stated, the cells were harvested by centrifugation at 10,000 rpm for 10 min, washed twice in sterile phosphate buffered solution (PBS, Oxoid LTD, UK) and finally resuspended in PBS.

Table 2: List of microorganisms, their origin, growth media, substrate and ACP system applied.

Microorganisms	Growth media	Type of system	Mode of growth	DBD ACP applied
<i>Escherichia coli</i> ATCC 25922* (Clinical isolate)	TSB+G	MRD/PBS	Planktonic	DIT60
<i>Escherichia coli</i> NCTC 12900** (Human isolate, serotype O157:H7 non-toxigenic)	TSB-G	Fresh produce	Planktonic	DIT120
		Abiotic surface	Biofilm	
<i>Escherichia coli</i> BL21 (GFP)*** (<i>E. coli</i> B strain)	TSB-G/ AMP	Lettuce broth	Planktonic	DIT120
		Fresh produce	Biofilm	
<i>Escherichia coli</i> XL10 (GFP)**** (<i>E. coli</i> K-12 derivative)	TSB-G/ AMP	Fresh produce	Biofilm	DIT120
<i>Salmonella enterica</i> serovar Typhimurium ATCC 14028* (Animal tissue isolate)	TSB-G	Fresh produce	Planktonic/ Biofilm	DIT120
<i>Listeria monocytogenes</i> NCTC 11994* (Cheese isolate, serotype 4b)	TSB-G	Lettuce broth	Planktonic	DIT120
		Fresh produce	Planktonic/ Biofilm	
		Abiotic surface	Biofilm	
<i>Pseudomonas aeruginosa</i> ATCC 27853* (Blood culture isolate)	TSB-G	TSB/ Abiotic surface	Planktonic/ Biofilm	DIT120
<i>Staphylococcus aureus</i> NCTC 1803* (Mammal, ovine gangrenous mastitis)	TSB-G	Abiotic surface	Biofilm	DIT120

* Strains were obtained from the microbiology stock culture of the School of Food Science and Environmental Health of the Dublin Institute of Technology.

** Strain was obtained from National Collection of type cultures of the Health Protection Agency (HPA, UK).

*** Strain was obtained from the microbiology stock culture of the Focas Research Institute of the Dublin Institute of Technology.

**** Strain was obtained from the microbiology stock culture of the School of Biochemistry and Immunology, Trinity Biomedical Sciences Institute, Trinity College Dublin.

2.2. Cultivation of CHO-K1 cells

Chinese hamster ovary cells (CHO-K1) were grown in Dulbecco's Modified Eagle's Medium/Ham's F-12 Nutrient Mixture (DMEM/F12, SigmaAldrich, Ireland) containing 2 mM L-glutamine and 10 % (v/v) foetal bovine serum (FBS) at 37°C and 5% carbon dioxide (CO₂). Confluent cell layers were washed with PBS and enzymatically detached using trypsin/EDTA.

2.3. Liquid systems preparation

2.3.1. Preparation of MRD and PBS bacterial cell suspensions

In order to investigate the effect of extrinsic parameters on antimicrobial efficacy of ACP, *E. coli* ATCC 25922 suspended in liquid media, MRD and PBS, was utilised. After washing the cells in PBS, the overnight culture's cell density was determined by measuring absorbance at 550 nm using the McFarland standard (BioMérieux, Marcy-l'Etoile, France) to allow a working inoculum corresponding to ~8.0 log₁₀ CFU/ml to be prepared. For plasma treatment, cells were adjusted to a density of ~7.0 log₁₀ CFU/ml in PBS and MRD. The concentration of inoculum was confirmed by plating appropriate dilutions on TSA, followed by incubation at 37°C for 24 h.

2.3.2. Preparation of Methylene Blue aqueous solution

Analytical-grade methylene blue reagent (MB, Sigma-Aldrich, Dublin, Ireland) was utilised in this study. Preliminary studies demonstrated that the efficacy of ACP to reduce the colour intensity of MB was influenced by the concentration of MB (data not shown). Therefore, MB was diluted to an optical density (OD) of 4.2

(maximum measurement range of the spectrophotometer) and further used as a working solution. Deionized water was used as a solvent.

2.3.3. Effect of reduced pH on bacterial cell proliferation

In order to determine any effects of reduced pH on the microbial inactivation, experiments were conducted by inoculating *E. coli* ($\sim 7.0 \log_{10}$ CFU/ml) in MRD with pH level (adjusted with 0.1 M HCl) of 3.5, 4.5 and 5.5. Inoculated MRD samples were incubated at room temperature for 0 h, 6 h and 24 h. Bacterial population incubated in MRD with pH ~ 7.0 was used as a control.

2.3.4. Preparation of lettuce broth and inoculation procedure

Lettuce broth (LB) was prepared as for the method described by Shen *et al.* (2012) with minor modifications. Lettuce juice, extracted by processing of iceberg lettuce in a commercial household juice maker (model JE3 1/03, Breville, UK), was centrifuged (10,000 rpm for 10 min at 4°C) twice to remove coarse particles. Supernatants were passed through paper filters (Whatman, England, UK), then through 0.45 μm filters (Millipore, Ireland), sterilized through 0.2 μm membrane filters (Millipore, Ireland) and then diluted in sterile distilled water to make 3% LB (pH 6.3).

After washing, *Salmonella*, *E. coli* BL21 and *L. monocytogenes* cell population density was determined by measuring absorbance at 550 nm using the McFarland standard. Prepared LB (3%) was inoculated with an appropriate amount of bacterial suspension corresponding to a final cell density of $\sim 7.0 \log_{10}$ CFU/ml. Bacterial concentration in LB was confirmed by plating appropriate dilutions on TSA, followed by incubation at 37°C for 24 h.

2.3.5. Preparation of *P. aeruginosa* cell suspension and supernatant

P. aeruginosa was incubated for 24 h at 37°C and unwashed cell suspension was used in the study of inhibition of *P. aeruginosa* quorum sensing (QS) controlled virulence factors. A separate set of experiments for determination of pyocyanin levels was conducted using 24 h grown *P. aeruginosa* culture cell free supernatant. Cell free *P. aeruginosa* supernatant was produced by centrifugation of culture at 10,000 rpm for 10 min.

2.4. Fresh produce preparation

2.4.1. Preparation of cherry tomatoes and strawberries

Fresh cherry tomatoes, strawberries were purchased from the local supermarket and stored at 4°C until use. The tomatoes were 2 ± 0.5 cm in diameter and 5-15 g in weight. Strawberries weight was approximately 10-20 g. The same brand and type of produce was used for each experiment. Cherry tomatoes were sterilized with 70% of ethanol (Klerwipe 70/30, Shield Medicare LTD, Farnham, UK) in order to reduce the background microbial load before surface inoculation of respective bacterial strain. Strawberry samples were not subjected to ethanol sterilisation. Sterilized tomatoes were then washed with sterile deionized water to remove any remaining ethanol residue and allowed to dry in the laminar flow safety cabinet at 23°C for 1 h prior to inoculation (Mattson *et al.* 2011). In order to assess ACP treatment efficacy for reduction of the background microflora, unsterilized tomatoes were also used.

2.4.2. Inoculum preparation

In order to investigate the effect of ACP treatment on bacteria inoculated on surface of fresh produce, three bacterial strains, *E. coli*, *Salmonella* and *L. monocytogenes*, were utilised. Overnight cultures of bacterial cultures were washed and resuspended in PBS, resulting in concentration of 8.0 – 9.0 log₁₀ CFU/ml, which were used as the working inoculum. The concentration of inoculum was confirmed by plating appropriate dilutions on TSA, followed by incubation at 37°C for 24 h for *E. coli* and *Salmonella* and 48 h for *L. monocytogenes*.

2.4.3. Inoculation procedure

For inoculation, tomatoes and strawberries were placed with the blossom end down on sterile petri dishes. The samples were spot-inoculated with bacteria applying either 50 µl or 100 µl of a culture on the tomato or strawberry surface, respectively (Das *et al.* 2006; Mahmoud *et al.* 2007). The droplets were deposited in several different locations, ensuring that the inoculum did not flow to the side of the samples. Inoculated samples were dried for 1 h in laminar flow safety cabinet to allow the attachment of bacteria on the surface of produce prior to the ACP treatment.

In order to evaluate ACP treatment efficacy against background microflora, uninoculated samples were used.

2.5. Bacterial biofilm formation on abiotic surface

2.5.1. Inoculum preparation

In order to investigate the effect of ACP treatment on bacterial biofilms, two Gram-negative bacteria, *E. coli* NCTC 12900 and *P. aeruginosa* ATCC 27853, and two Gram-positive bacteria, *S. aureus* NCTC 1803 and *L. monocytogenes* NCTC 11994, which are of potential biomedical and food concerns, were selected. An unwashed overnight culture of each bacterium were diluted in TSB to a cell density of $\sim 7.0 \log_{10}$ CFU/ml, using McFarland standard. This bacterial cell concentration was further used as inoculum for biofilm formation. Bacterial biofilms of the four microorganisms selected were produced in 96 well plate for ACP treatment and further assessment by colony count and XTT assays.

2.5.2. Biofilm formation

P. aeruginosa biofilm was produced on glass coverslips (24 x 32 mm) for confocal laser scanning microscopy analysis (CLSM). For the scanning electron microscopy (SEM) analysis, *P. aeruginosa* biofilms were developed using tissue culture treated inserts containing polycarbonate membrane (0.45 μm , Millicell, Millipore, Ireland). *E. coli* biofilms were produced on track-etched polyethylene terephthalate (PET) membranes inserts with 0.4 μm pore size (Becton Dickinson Labware, USA) for SEM.

Biofilms in a 96 well plate were obtained by adding 200 μl of TSB bacterial suspension ($7.0 \log_{10}$ CFU/ml) into the wells of the plates. For production of biofilms for CLSM, coverslips were positioned inside the wells of the 6 well culture plate and 8 ml of TSB bacterial suspension was added. For production of

biofilms on polycarbonate or PET membranes, inserts were placed inside wells of the 6 well plate, which were filled with 2 ml of TSB bacterial suspension. The 96 well plates were incubated at 37°C for either 24 or 48 h and the 24 h biofilms were used only for biofilm biomass analysis using crystal violet (CV) assay. For formation of 48 h old biofilm in either 96 well plates, on glass cover slips or inserts, after 24 h of incubation the supernatant from each well was replaced with corresponding fresh TSB, with further incubation for 24 h. After incubation, the TSB containing suspended bacterial cells was removed and the substrates were rinsed three times with sterile PBS, leaving only bacterial biofilms for further investigations. Negative controls were obtained by using TSB without inocula for the XTT assay. Prior to each experiment, the biofilms were air dried for 60 min.

2.6. Bacterial internalisation and biofilm formation on lettuce

2.6.1. Preparation of lettuce

Fresh iceberg lettuce (Class I, Origin: Spain) was purchased from the local supermarket on the day of the experiment and stored at 4°C until use. The outer lettuce leaves were removed and intact inner leaves were selected for the experiment. The leaves were aseptically cut into 5 x 5 cm pieces, each of 1.7 – 2.4 g, using a sterile scalpel and immediately used in the experiments.

2.6.2. Inoculum preparation

For lettuce inoculation studies, three bacterial strains were used, *Salmonella enterica* serovar Typhimurium ATCC 14028, ampicillin resistant *E. coli* BL21 and *Listeria monocytogenes* NCTC 11994. Bacterial suspension (10 ml) was washed

and resuspended in PBS and then transferred into 1 L of sterile deionised water to achieve a final cell concentration of approximately $7.0 \log_{10}$ CFU/ml, which was further used as a working inoculum. The concentration of inoculum was confirmed by plating appropriate dilutions on TSA, followed by incubation at 37°C for 24 h for *Salmonella* and *E. coli* and 48 h for *L. monocytogenes*.

2.6.3. Inoculation procedure

The lettuce inoculation procedure was conducted as described by Kroupitski *et al.* (2009) with minor modifications. Lettuce pieces were submerged in a sterile beaker containing 300 ml of bacterial suspension in the laminar flow cabinet and incubated for 2 h. Immediately after inoculation, lettuce samples were either ACP treated or further stored for biofilm formation and internalisation studies (see section 2.5.2).

2.6.4. Internalisation and biofilm formation

Following incubation for 2 h, inoculated lettuce samples were rinsed with sterile deionised water in a separate beaker in order to remove unattached bacteria, drained and dried on sterile aluminium foil in the laminar flow cabinet for 15 min from both sides. Following air-drying, the samples were transferred into sterile petri dishes and incubated for 24 and 48 h at either room temperature (~22°C) or 4°C in light/dark photoperiod (day/night regime) for biofilm formation and internalisation. In a separate experiment, to assess the influence of light on microbial attachment, the samples were incubated for 24 h and 48 h at 4°C in the dark.

For CLSM observations, 1 x 1 cm pieces excised from the lettuce leaf were spot-inoculated on both sides using *E. coli* XL10 (GFP) culture grown overnight and washed in PBS (100 µl) and further incubated for 24 h at either room temperature or 4°C in the light/dark photoperiod and 4°C under dark conditions.

For SEM analysis lettuce pieces were inoculated with *Salmonella* Typhimurium and further incubated for 48 h at room temperature and the light/dark photoperiod.

2.7. Experimental design

2.7.1. ACP systems set-up

Two DBD ACP systems were evaluated in this study, i.e. DIT60, a 60 kV transformer and DIT120, a 120 kV transformer. The schematic of the DBD ACP systems set up are represented in Fig. 3.

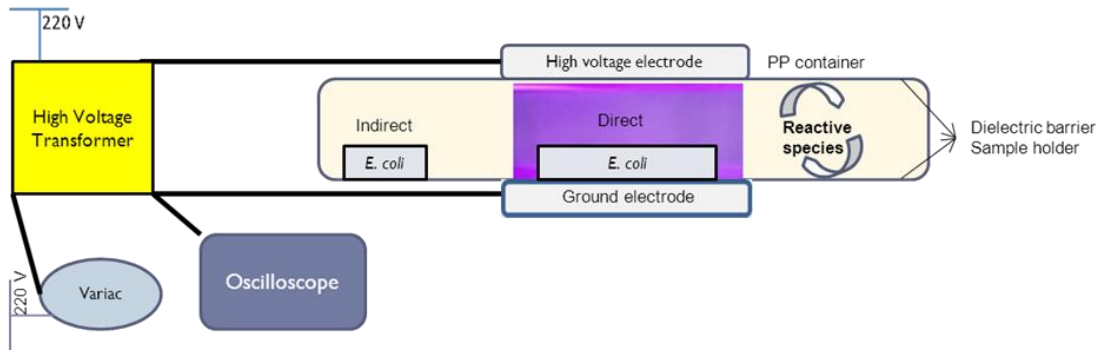

Figure 3: Schematic diagram of DBD ACP plasma generator.

In general, DIT60 device is a novel prototype atmospheric low temperature plasma generator. The system consists of a variable high voltage transformer with an input voltage of 230 V at 50 Hz and a maximum high voltage output of 60 kV at 50 Hz (Fig. 4a). The DIT120 has a maximum voltage output of 120 kV at 50 Hz (Fig. 4b).

In both systems, the two 15 cm diameter aluminium disk electrodes were separated by a rigid polypropylene container (310 x 230 x 20/40 mm), which served as both a sample holder and as a dielectric barrier with wall thickness of 1.2 mm. The distance between the two electrodes was equal to the height of the container, either 20 mm used for liquid and biofilm studies or 40 mm used for fresh produce studies (tomato/strawberries), where plasma discharge was generated. Voltage on DIT60 was monitored using an InfiniVision 2000 X-Series Oscilloscope (Agilent Technologies Inc., USA), whereas on DIT120 voltage can be monitored on the display and read as a kV peak-to-peak or kV_{RMS}, respectively. The output voltage on DIT60 is distributed equally between the two electrodes, whereas in the case of DIT120 the voltage is transformed onto the top electrode, i.e. top electrode is the main output voltage carrier, and on the ground electrode the voltage is always zero. Experiments were performed at 40 kV peak-to-peak on DIT60 and 60, 70 or 80 kV_{RMS} on the DIT120 at atmospheric pressure conditions. It should be noted, that the electrodes on the DIT60 and DIT120 were exposed to the surrounding air, which were utilised for liquid systems and fresh produce studies. For the biofilm studies the top electrode of the DIT120 system was completely surrounded by a dielectric material, as can be seen on Fig. 4(b), which allowed application of higher voltages.

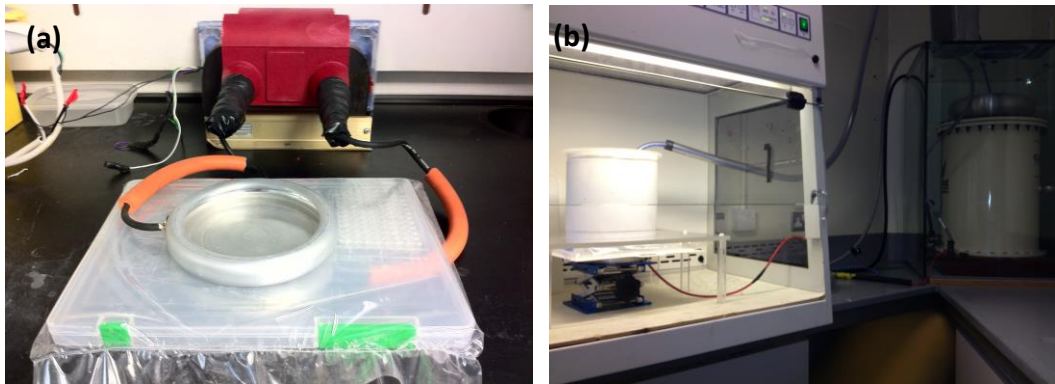

Figure 4: DBD ACP systems.

(a) DIT60 and (b) DIT120.

2.7.2. Samples position with respect to the ACP discharge

Microbial samples were placed in the centre of the plastic container directly between the electrodes within the plasma discharge for direct ACP treatment (Fig. 5a). For indirect ACP treatment, a separate container was used and samples were placed so as to achieve treatment outside the plasma discharge (Fig. 5b). The distance between the sample and top electrode for direct ACP treatment was 10 mm. For indirect treatment, the distance between the samples and centre of the electrodes varied from 120 mm to 160 mm due to samples distribution in the microtiter plate.

Inoculated fresh produce, cherry tomatoes, strawberries or lettuce, were positioned inside the rigid container so as to expose the samples to indirect ACP exposure. The distance from the centre of the electrodes varied from 140 mm to 160 mm (Fig. 5c).

After samples loading, each container was sealed with the high barrier polypropylene bag (Cryovac, B2630, USA) and placed between the aluminium electrodes of the transformer.

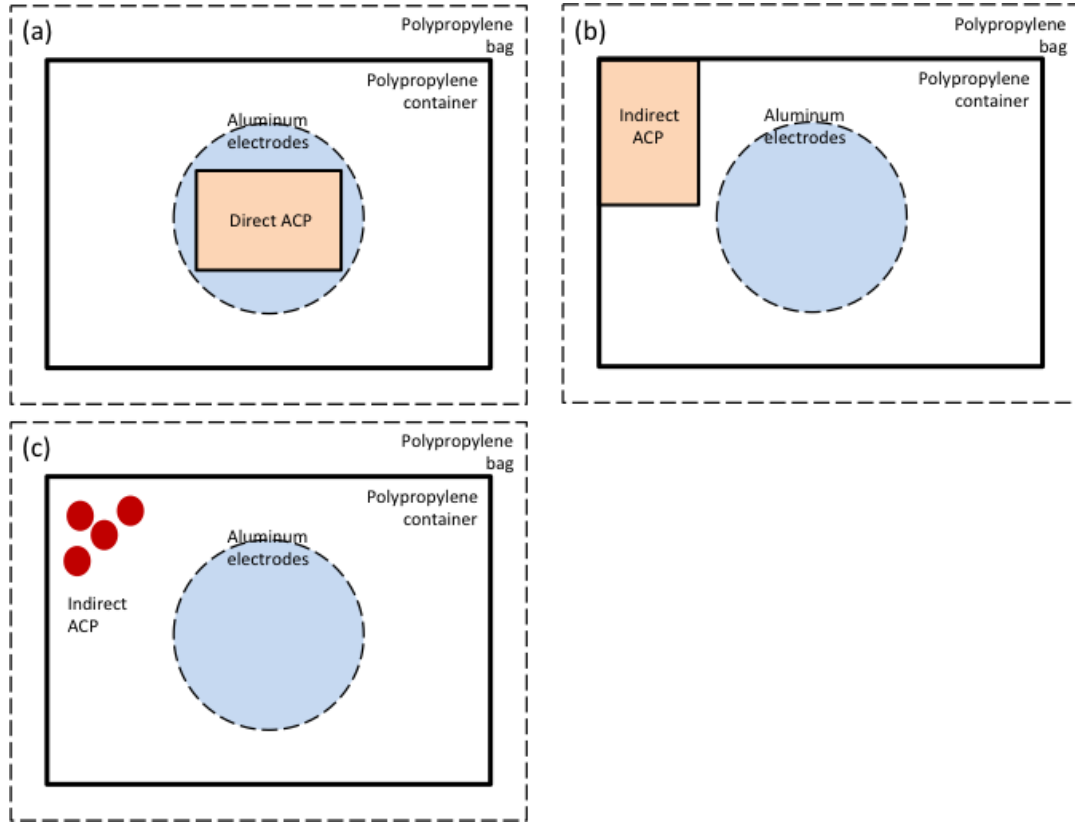

Figure 5: Position of samples inside polypropylene container with respect to the ACP discharge.

(a) direct, (b) and (c) indirect ACP treatment.

2.7.3. ACP treatment of liquid systems

Liquid systems, i.e. MRD and PBS *E. coli* cell suspensions, were treated with ACP for 10, 20, 30, 45, 60, and 300 s on DIT60 at voltage of 40 kV. In order to assess any retention effect of plasma generated reactive species over time, samples were stored at room temperature for 0, 15, 30, and 60 min following 300 s of plasma

treatment or 1 h and 24 h after 60 s of treatment. Samples treated with shorter treatment intervals (10, 20, 30, and 45 s) were stored at room temperature for 24 h. In order to assess the effect of voltage on bactericidal efficiency of ACP treatment, *E. coli* suspended in MRD and PBS were treated directly and indirectly for 30 s with either 40 kV or 56 and 70 kV on either DIT60 or DIT120 system, respectively, with subsequent storage for 24 h at room temperature.

In order to assess the effect of gas composition on ACP decontamination efficiency, atmospheric air and two different gas mixtures, such as 90% N₂ + 10% O₂ and 65% O₂ + 30 CO₂ + 5% N₂, were utilized. The samples were treated on DIT120 by either direct or indirect ACP for 30 s with the subsequent storage at room temperature for 24 h. The effect of different voltage levels of 56 and 70 kV were also examined. Untreated control bacterial samples were used to assess any effect of the gas mixtures on bacterial survivability within 24 h of storage.

The inoculated LB samples were treated with 80 kV_{RMS} for 30 s in air at atmospheric pressure.

2.7.4. ACP treatment of fresh produce

Fresh produce samples, namely four of either tomatoes or strawberries, or two lettuce pieces, were aseptically transferred inside the container. The inoculated and uninoculated tomatoes and strawberries were treated using DIT120 at 70 kV for 10 - 300 s. Lettuce samples were treated using DIT120 at 80 kV for 300 s in air and at atmospheric pressure. Tomato and strawberry samples were stored post treatment storage for 24 h at room temperature, while lettuce samples were stored for 24 h at 4°C. To evaluate any possible effect of storage on the bacterial growth,

corresponding inoculated control samples were stored for 24 h under matching post treatment storage conditions. All experiments were performed in duplicate and replicated at least twice to ensure reproducibility of the experimental data and are reported as \log_{10} CFU/sample for bacterial reductions on produce, where each tomato, strawberry and lettuce sample weighed an average of 10, 15 and 2 g, respectively.

2.7.5. ACP treatment of bacterial biofilms on abiotic surface

Microtiter plates containing bacterial biofilms of either *E. coli*, *L. monocytogenes*, *S. aureus* and *P. aeruginosa* were treated with ACP generated on DIT120 at 80 kV and atmospheric air. The samples were either untreated (0 h control) or treated with either direct or indirect ACP for 60, 120 and 300 s and subjected to post treatment storage for 24 h at room temperature. Untreated control samples were stored for 24 h at identical conditions in order to assess any possible effects of storage (24 h control). All experiments were conducted by using three independently grown cultures and repeated at least two times.

For SEM and CLSM analyses, *P. aeruginosa* 48 h biofilms were either untreated (0 h control) or treated with 80 kV ACP directly or indirectly for 300 s. SEM analysis of *E. coli* biofilms was conducted using untreated (0 h control) samples and directly treated with ACP for 300 s samples.

2.7.6. ACP treatment of *P. aeruginosa* (QS studies)

P. aeruginosa was grown for 24 h in TSB and either the cell suspension or *P. aeruginosa* cell-free supernatant (10 ml) was dispensed in a petri dish and treated with direct or indirect ACP for 60, 120 and 300 s followed by a post treatment

storage time of 24 h at room temperature. Control samples were left untreated (0 h control) or untreated and stored for 24 h (24 h control) under identical storage conditions to assess possible effects of 24 h of post treatment storage on bacterial viability and enzymatic activity.

2.8. Post ACP treatment analysis

2.8.1. Liquid systems

2.8.1.1. Microbiological analysis

The effect of ACP treatment on the microbial load was determined in terms of reduction in viable counts. ACP treated samples of either PBS, MRD or LB were pooled together from the wells into sterile eppendorf tubes, serially diluted in MRD and 0.1 ml aliquots of appropriate dilutions were surface plated on TSA. The plates were incubated at 37°C for 24 h. In order to detect a further possible increase in the formation of visible colonies, the plates were further incubated for 2-3 days. Results were presented as surviving bacterial population in log₁₀ CFU/ml units. All experiments were carried out in duplicate and replicated at least twice.

2.8.1.2. The effect of reduced pH

After incubation of *E. coli* (~7.0 log₁₀ CFU/ml) in MRD with pH level of 3.5, 4.5 and 5.5 for 0 h, 6 h and 24 h, samples were serially diluted in MRD, and *E. coli* population densities were determined by surface spreading on TSA.

2.8.1.3. Analysis of MB discoloration rate

In order to assess MB decolourisation rate, the change in the absorbance was measured using a microplate reader (Synergy HT, Biotek Instruments Inc.). The

absorbance was recorded at 600 nm before and after ACP processing, i.e. treatment and subsequent storage. The MB discoloration rate was calculated as follows:

$(A_0 - A_{ACP}) / A_0 \times 100\%$, where A_0 is the absorbance of initial untreated sample and A_{ACP} is the absorbance of a treated sample measured at 600 nm.

2.8.1.4. pH measurements

The pH of a series of uninoculated samples treated in microtiter plate and pooled for analysis was monitored using a glass electrode pH-meter (Orion Model, England) prior to and after ACP processing.

2.8.2. Fresh produce: cherry tomato and strawberry

For microbiological analysis, inoculated untreated control samples (to estimate initial attached bacterial population), inoculated untreated samples stored for 24 h (to assess the effect of storage on microbial growth), uninoculated untreated control samples (to determine initial background microflora), and either inoculated or uninoculated ACP treated samples were analysed. The samples were aseptically transferred into separate sterile stomacher bags (BA6041, Seward LTD, UK) with 10 ml of sterile MRD and hand rubbed for 2-3 min. The resulting suspension was serially diluted in MRD. The surviving *E. coli*, *Salmonella* and *L. monocytogenes* populations were determined by agar overlay method (Mahmoud 2010). Briefly, aliquots of an appropriate dilution were surface plated on TSA, incubated for 2-4 h, and overlaid with the appropriate selective media: Sorbitol MacConkey agar (SMAC, ScharlauChemie, Spain) supplemented with Cefixime-Tellurite (CT, Oxoid LTD, England) for *E. coli*, Xylose Lysine Deoxycholate agar (XLD, ScharlauChemie, Spain) for *Salmonella*, and polymyxin-acriflavine-LiCl-

ceftazidime-aesculin-mannitol (PALCAM, ScharlauChemie, Spain) supplemented with PALCAM Listeria Selective Supplement (Oxoid LTD, England) for *L. monocytogenes*. Plates were then incubated for 24-48 h at 37°C.

Surviving background microflora of the uninoculated samples was evaluated using non-selective media TSA for estimation of aerobic mesophilic bacteria and Potato Dextrose agar (PDA, ScharlauChemie, Spain) for estimation of yeasts and moulds, with further incubation of agar plates at 37°C for 48 h and 5 days, respectively. The results represent the mean value of three independent experiments and are reported as log₁₀ CFU/sample.

2.8.3. Bacterial biofilms formed on abiotic surfaces

Crystal violet (CV) staining was utilised in order to monitor *E. coli*, *L. monocytogenes*, *S. aureus* and *P. aeruginosa* biofilm formation capacity using 24 and 48 h incubation times. The effect of ACP treatment on viability of *E. coli*, *L. monocytogenes*, *S. aureus* and *P. aeruginosa* biofilms was determined using standard colony count method and XTT (2,3-bis (2-methoxy-4-nitro-5-sulfophenyl) [phenyl-amino)car-bonyl]-2H-tetrazolium hydroxide, SigmaAldrige, Ireland) assay for determination of cell viability/culturability and metabolic activity, respectively. The ability of the contained ACP reactive species to penetrate through the biofilms complex structures was observed using 48 h *P. aeruginosa* biofilm stained with LIVE/DEAD bacterial viability kit followed by CLSM. SEM was conducted using *P. aeruginosa* and *E. coli* 48 h biofilms in order to observe morphological changes of biofilms caused by ACP treatment.

2.8.3.1. *Crystal violet assay*

The biofilm mass was quantified using CV assay, as described in Peeters *et al.* (2008) with minor modifications. After biofilm formation during 24 and 48 h of incubation, the wells of the 96 well microtiter plate were washed and dried as described in section 2.5.1. For fixation of the biofilms 200 μ l 99% methanol was added for 15 min after which supernatants were removed and the plates were air-dried. CV solution (Merck, Portugal) (200 μ l) was added into the wells containing biofilms and the wells containing negative controls (TSB without inocula). After 20 min CV was removed by rinsing with sterile water until the water is clear. Then CV was released by adding 200 μ l of 33% acetic acid. The absorbance was measured at 590 nm on microplate reader (Synergy HT, Biotek Instruments Inc.). Each absorbance value was corrected by subtracting the means of absorbance of a blank (uninoculated TSB). Experiments were carried out in triplicate and repeated at least twice.

2.8.3.2. *Colony count assay*

Following ACP treatment and post treatment 24 h storage, 100 ml of sterile PBS was added into the biofilm containing wells. In order to disrupt biofilms, the plates were sonicated using a water table sonicator (Branson 5510E-MT, USA, Mexico) for 5 min. Suspensions were pooled together from the wells into sterile eppendorf tubes, serially diluted in MRD and 0.1 mL aliquots of appropriate dilutions were surface plated on TSA and incubated at 37°C for 24-48 h. Results were presented as surviving bacterial population in log₁₀ CFU/ml units.

2.8.3.3. XTT assay

Prior to each assay, fresh solution of 2,3-bis (2-methoxy-4-nitro-5-sulfophenyl) [phenyl-amino)car-bonyl]-2H-tetrazolium hydroxide (XTT, 1 mg/ml, Sigma-Aldrich Co., Ireland) was prepared, as described in Peeters *et al.* (2008). Briefly, XTT (4 mg) was dissolved in 10 ml of prewarmed 1X PBS. The solution was supplemented with 55 mg menadione (Sigma-Aldrich Co., Ireland) in 100 ml acetone (Sigma-Aldrich Co., Ireland). The wells containing biofilms and negative controls (TSB without inocula) were filled with sterile PBS (100 µl) and then XTT-menadione (100 µl) was added to all wells. Plates were incubated for 5 h at 37°C in the dark. After incubation, the supernatant (100 µl) from each well was transferred into the wells of a new 96 well microtiter plate and the absorbance was measured at 486 nm on microplate reader. The percentage of surviving bacterial population was calculated as $((A_{ACP}-A_C)/A_0) \times 100\%$, where A_{ACP} , A_C and A_0 are the absorbance of ACP treated, negative control and untreated control biofilms, respectively.

2.8.3.4. CLSM analysis of *P. aeruginosa*

Prior to analysis, in order to differentiate viable and dead bacteria, *P. aeruginosa* untreated controls and biofilms treated with either direct or indirect ACP for 300 s were stained with LIVE/DEAD bacterial viability kit, containing SYTO9 and propidium iodide (PI, SigmaAldrich, Ireland). Biofilms grown on glass coverslips were covered with 200 µl of SYTO9 and PI solution prepared according to manufacturer's instructions and incubated for 15 min in dark. The samples were rinsed with sterile deionised water, placed on the microscope glass slide and

imaged using Zeiss confocal microscope (Carl Zeiss, Model: LSM 510, Germany). Quantitative characterisation of biofilm thickness was obtained from CLSM stack images and further analyzed using IMARIS image analysis software (Bitplane, Inc.). The maximum thickness of biofilms was determined from the value of the Y-axis.

2.8.4. Bacterial biofilms and internalised bacteria formed on lettuce

For microbiological analysis, inoculated untreated control lettuce samples (to estimate initial bacterial planktonic or biofilm population), inoculated ACP treated and stored for 24 h at 4°C samples and inoculated untreated controls stored for 24 h of post treatment storage time (to estimate the effect of 24 h storage on microbial growth) were analysed. Lettuce samples were aseptically transferred into separate sterile stomacher bags (BA6041, Seward LTD, UK) with 10 ml of sterile maximum recovery diluent (MRD, ScharlauChemie, Spain) and homogenised for 2 min in the stomacher (Model: BA6020, England). The resulting suspension was serially diluted in MRD. The surviving *Salmonella* and *L. monocytogenes* populations were determined by agar overlay method as described in section 2.7.2. TSA supplemented with ampicillin was used for *E. coli*. Plates were then incubated for 24-48 h at 37°C.

2.8.4.1. CLSM analysis of *E. coli*

In order to study the effect of different temperature and light storage conditions on the bacterial proliferation on lettuce, CLSM analysis was conducted utilising GFP expressing *E. coli* XL10. Inoculated untreated samples were analysed using Leica

confocal microscope (Leica, Model: TCS SP8 STED) with excitation/emission 488/500-520 nm laser lines and 20x lenses and at least 10 randomly chosen microscopic fields were examined for each sample incubated at each storage condition studied. The images were obtained using IMARIS image analysis software (Bitplane, Inc.)

2.8.5. SEM analysis

SEM analysis was employed to assess the cellular damage of *E. coli* ATCC 25922 suspended in MRD after treatment with ACP for 30 s, effect of ACP treatment on *P. aeruginosa* and *E. coli* 48 h biofilms formed on abiotic surface and *Salmonella* 48 h biofilms formed on lettuce at room temperature and light/dark photoperiod, as well as to observe the attachment of bacteria, namely *E. coli* NTCC 12900 and *L. monocytogenes* on tomato and strawberry samples prior treatment.

Bacterial cells in liquids either ACP treated or untreated were prepared as described by Thanomsub *et al.* (2002). Preparation of tomato and strawberry samples were performed as described by Gratao *et al.* (2009) and biofilm formed on lettuce and inserts containing polycarbonate membrane were prepared as described by Srey *et al.* (2014b).

To prepare the pellet, *E. coli* samples in MRD were concentrated by centrifugation at 10,000 rpm for 10 min. For the assessment of attached bacteria, inoculated tomato, strawberry, lettuce samples and polycarbonate membrane were dried under laminar flow at 23°C. The tissue from the inoculated sites of the produce was excised forming ~1 cm in diameter and ~1 mm of thickness pieces. The

polycarbonate membrane was excised from the inserts forming appropriate pieces for the analysis ($\leq 1 \times 1$ cm).

The cells were fixed in ice-cold 2.5% glutaraldehyde in 0.05 M sodium cacodylate buffer (pH7.4) (SCB) for 2 h. The cells were washed with the same buffer three times and fixed in 1% osmium tetroxide for 2 h at 4°C. After 2 h of fixation, bacterial cells were washed with SCB followed by three washes with distilled water. The samples were dehydrated using increasing concentrations of ethanol (50%, 70%, 80%, 90%, 95%, and 99.5%). *E. coli* pellet and bacterial cells attached on tomato and strawberries were freeze dried (Labconco, FreeZone 6; Mason Technology, Dublin, Ireland), whereas *P. aeruginosa* and *E. coli* biofilms attached on membranes and *Salmonella* biofilms attached on lettuce were dehydrated using 33%, 50%, 66%, and 100% (v/v) hexamethyldisilazane (Sigma Aldrich, Ireland). In order to prevent surface charging by the electron beam, the samples were sputter-coated with gold particles using Emitech K575X Sputter Coating Unit resulting in a coating of 10 nm after 30 s. The samples were examined visually using a FEI Quanta 3D FEG Dual Beam SEM (FEI Ltd, Hillsboro, USA) at 5 kV.

2.8.6. Intracellular reactive oxygen species (ROS) measurements

In order to examine if organic matter present in contaminated suspensions has any effect on generation of ROS within the bacterial cells, 2',7'-dichlorofluorescein diacetate (DCFH-DA) assay (Sigma Aldrich, Ireland) was utilised. DCFH-DA is a non-fluorescent cellular probe, which turns to a highly fluorescent 2',7'-dichlorofluorescein (DCF) upon oxidation by ROS and can be directly correlated to ROS concentration. To detect intracellular ROS, *L. monocytogenes* and *E. coli*

BL21 (Gram-positive and Gram-negative, respectively) suspended in PBS and LB (3%) with final cell concentration of $\sim 7.0 \log_{10}$ CFU/ml were subjected to 30 s of ACP treatment and 0 h of post treatment storage. Immediately after treatment cell suspensions were incubated with DCFH-DA at a final concentration of 5 μ M in PBS for 15 min at 37°C. Aliquots of each sample (200 μ l) were transferred to 96 well fluorescence microplate wells (Fisher Scientific, UK) and measured by SynergyTM HT Multi-Mode Microplate Reader (BioTek Instruments Inc.) at excitation and emission wavelengths of 485 and 525 nm. Due to the high autofluorescence of LB, fluorescence values obtained for treated LB bacterial suspensions were corrected by subtracting the means of fluorescence of a blank (uninoculated) LB. Experiments were carried out in duplicate and repeated at least twice.

2.8.7. Quorum sensing assays

2.8.7.1. Pyocyanin assay

Pyocyanin (*rhl*-controlled QS system) present in *P. aeruginosa* TSB suspension or supernatant was extracted following a procedure described by Karatuna and Yagci (2010). Briefly, bacterial cell suspensions or culture supernatants, either untreated (0 h and 24 h controls) or ACP treated and stored for 24 h post treatment, were centrifuged for 10 min at 10,000 rpm. The supernatant (5 ml) was transferred into a 25 ml tube containing 3 ml of chloroform and the resulting chloroform layer (3 ml) was mixed with 1.5 ml of 0.2 M hydrochloric acid. The solution containing extracted pyocyanin (top layer) was transferred into the wells of a 96 well plate and

the absorbance was measured using a microtiter plate reader at 520 nm. An average absorbance value obtained from 10 wells was corrected by subtracting the mean of the absorbance of a blank (uninoculated) TSB. Experiments were repeated at least three times.

2.8.7.2. *Elastin-Congo red assay*

The effect of ACP treatment on *P. aeruginosa* elastolytic activity (Las B), controlled by the *las* QS system, was determined using elastin-congo red conjugate (Sigma Aldrich, Ireland), as the most specified substrate for elastases, following the procedure described by (Amaya *et al.* 2012). Either untreated 0 h and 24 h controls or ACP treated bacterial suspensions were centrifuged for 10 min at 10,000 rpm. Elastin-congo red (2.5 mg) was suspended in 500 µl of 0.2 M Tris buffer (pH 8.8) in an eppendorf, vortexed, and mixed with 500 µl of *P. aeruginosa* supernatant. The resulting solution was incubated at 37°C for 24 h. After incubation, the samples were vortexed and centrifuged at 13,000 rpm for 10 min. The supernatant was dispensed into the wells of the 96 well microtiter plate and the absorbance of released congo red was measured at 495 nm. An average absorbance, corrected by the mean absorbance obtained from the corresponding mixture incubated in the absence of elastin-Congo red, represents *P. aeruginosa* enzymatic elastase activity. Experiments were repeated at least five times.

2.8.7.3. *Planktonic cell population density*

The possible changes in concentrations of *P. aeruginosa* planktonic cell populations caused by ACP treatment were monitored conducting colony count assay of bacterial samples treated with ACP either directly or indirectly for 60, 120, and 300 s and untreated 0 h and 24 h controls. Experiments were repeated at least six times and results were presented as surviving bacterial population in log₁₀ CFU/ml units.

2.8.7.4. *Biofilm formation*

The effect of ACP treatment on *P. aeruginosa* biofilm formation was examined using colony count assay. Samples treated with ACP and stored for 24 h or untreated 0 h as well as 24 h controls of *P. aeruginosa* TSB suspensions were dispensed into the wells of 96 well microtiter plates (200 µl). The plates were incubated for 24 h at 37°C. After incubation, the reduction in culturability of *P. aeruginosa* biofilms was assessed by colony count assay as described in section 2.4.1. Experiments were duplicated and repeated at least twice. Results were presented as surviving bacterial population in log₁₀ CFU/ml units.

2.8.7.5. *Cytotoxicity assay*

In order to examine if ACP-based reduction of virulence factors could further influence cytotoxicity of *P. aeruginosa*, a cytotoxicity assay using the CHO-K1 cell line was conducted. Detached cells, seeded in 96 well microtiter plates at final concentration of 2.5×10^4 cells/ml (100 µl per well), were supplemented with 10 µl

of filter-sterilised supernatant of either ACP treated or untreated (0 h and 24 h controls) *P. aeruginosa* cell suspension (filter pore size 0.2 µm). Uninoculated and ACP treated TSB medium was considered as negative controls. Cell growth/adhesion was assessed after incubation at 37°C and 5% CO₂ in air for 3 days using CV assay. Briefly, after incubation, supernatants were removed and adherent cell layers were fixed with 40 µl 70 % methanol for 1 min. After fixation, cells were stained with 50 µl of 0.2% CV solution for 10 min and then extensively washed with water. Adherent CV was dissolved in 10% acetic acid (100 µl per well) and the absorbance was measured at 600 nm on a microplate reader. Results are represented as a percentage of adherent cells determined by the absorbance of the CV, where cell culture supplemented with uninoculated and untreated TSB medium was set as a 100 %. Experiments were triplicated and repeated at least three times.

2.8.7.6 Temperature measurements

The temperature of the surface of TSB cell suspension and the 96 well plate measured immediately after 300 s of direct/indirect treatment using IR thermometer (Maplin Electronics, S63 5DL, UK) was 21/17°C and 24/18°C, respectively, whereas the temperature measured at the centre of the polypropylene container did not exceed 28°C.

2.8.9. Ozone measurements

Ozone measurements were taken with packages containing inoculated samples using Gastec ozone detector tubes (Product #18M, Gastec Corporation, Japan) as

an indicator of the metastable ROS generated by ACP. Measurements were taken immediately after plasma treatment and after 24 h of post treatment storage. Complete diagnostic of the ROS and reactive nitrogen species (RNS) generated within the package is described in detail in Moiseev *et al.* (2014).

2.9. Optical Emission Spectroscopy (OES)

OES of the discharge within empty packages were acquired with a Stellarnet EPP 2000C-25 spectrometer with an optical fiber input. The fiber optic from the OE spectrometer was placed behind a quartz window incorporated into the centre of the side wall of the polypropylene container. The fiber had a numerical aperture of 0.22 and was optimized for use in the ultraviolet and visible portion of the spectrum with a wavelength range of 190 nm to 850 nm.

2.10. Statistical analysis

Statistical analysis was performed using SPSS 19.0 (SPSS Inc., Chicago, USA). The surviving bacterial population of *E. coli*, *Salmonella* and *L. monocytogenes*, *P. aeruginosa*, MB discoloration rate, ozone concentration and pH values following ACP treatment were subjected to analysis of variance (ANOVA). Means were compared according to the method of Fisher's Least Significant Difference (LSD) at the 0.05 level.

For lettuce studies, statistical analysis was performed using IBM SPSS statistics 22 Software (SPSS Inc., Chicago, USA). The surviving population of *Salmonella*, *L. monocytogenes* and *E. coli* following ACP treatment were subjected to Mixed Design ANOVA (Repeated measures with a between subject factor). Means were compared according to the method of LSD at the 0.05 level. Adjustment for

multiple comparisons was made using Bonferroni method. Average bacterial population recovered from lettuce samples were compared within the 'time' subgroups: inoculated untreated controls and inoculated stored for 24 or 48 h ACP treated samples; and between the 'storage' groups, i.e. samples inoculated and stored at different temperature/light regimes: room temperature and light/dark, 4°C and light/dark and 4°C and dark either for 24 or 48 h followed by ACP treatment, and interactions between the 'time' group and 'storage' group were tested. The mean value of the untreated control samples represent an average of 0 h, 24 h and 48 h of untreated controls. The average reductions in populations of each bacteria type (*Salmonella*, *L. monocytogenes*, *E. coli*) have not been compared between each other.

Chapter 3: ACP DECONTAMINATION OF LIQUID SYSTEMS

The main objective of this study was to determine the influence of extrinsic DBD ACP critical control parameters on treatment inactivation efficacy against *E. coli* ATCC 25922. Parameters included treatment time, post treatment storage time, mode of ACP exposure, media composition, voltage level and processing gas composition. The effect of these parameters on antimicrobial effects of ACP was investigated by using two ACP systems, DIT60 and DIT120. Overall, based on these studies, optimum parameters of treatment time, post treatment storage time, mode of exposure, voltage level and type of gas were determined towards achieving significant reduction of microorganism within a short duration of treatment time.

3.1. Effect of treatment time, post treatment storage time, mode of exposure and media composition on ACP inactivation efficiency

Survival curves of *E. coli* in MRD and PBS treated with ACP for 300 s followed by post treatment storage for different time intervals are shown in Fig. 6. Direct ACP treatment (DIT60) of *E. coli* cells in MRD inactivated bacterial populations to undetectable levels, irrespective of a post treatment storage time of 0 to 60 min (Fig. 6a). However, when direct treatment in conjunction with 0 min of post treatment storage time was applied in PBS, reduction in bacterial levels by 1.8 log₁₀ CFU/ml was achieved, which was significant when compared with untreated controls ($P \leq 0.05$). Increasing post treatment storage time from 15 to 60 min reduced bacterial population to undetectable levels (Fig. 6a).

Indirect ACP treatment of bacterial cells in MRD and PBS with no post treatment storage (0 h) resulted in a reduction by 0.9 and 2.0 log cycles, respectively (Fig. 6b). Observations for indirect exposure after extending the post treatment storage time to 15 min were similar to that of direct ACP exposure and post treatment storage time of 0 min in MRD and PBS. Further increases in post treatment storage time resulted in complete inactivation of bacterial cells in both media.

Thus, plasma inactivation efficiency was found to be dependent on the post treatment storage time, which possibly allowed diffusion and action of the residual reactive species in liquids, regardless of the type of media used.

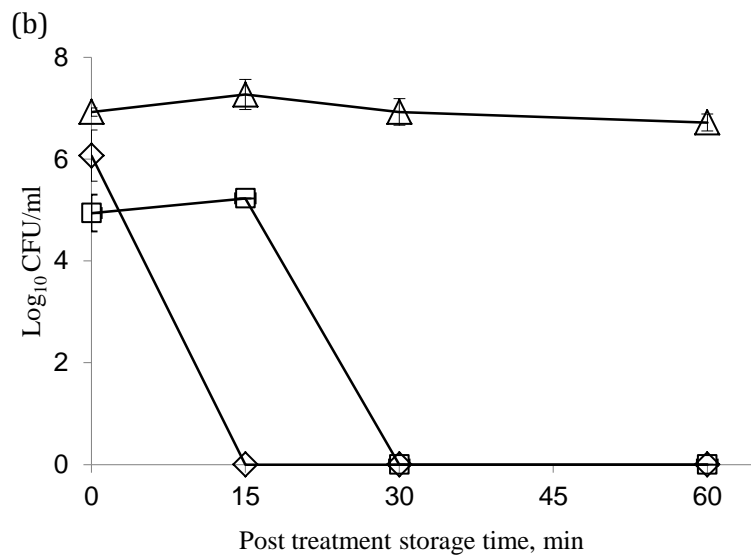
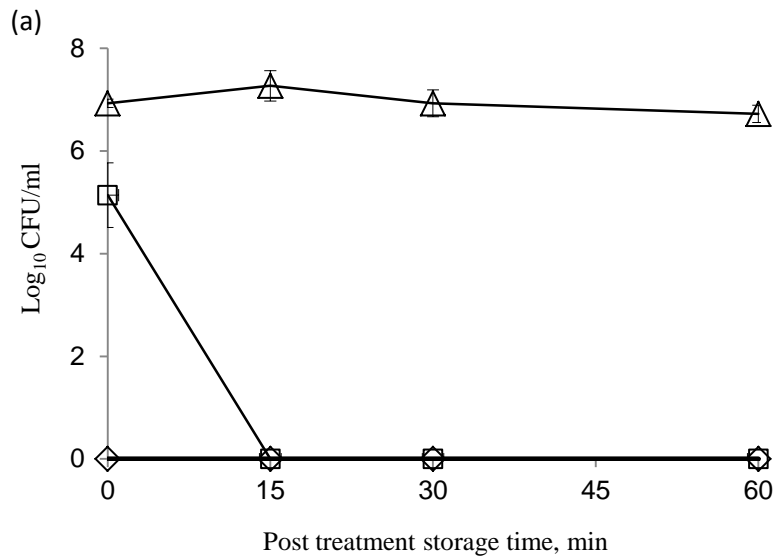

Figure 6: Effect of post treatment storage time on antimicrobial efficacy of ACP treatment against *E. coli*. Treatment time 300 s.

(a) direct and (b) indirect treatment: (Δ) control, (◇) MRD, (□) PBS. Vertical bars represent standard deviation.

The effect of reduced treatment time of 60 s on DBD ACP antimicrobial efficacy in conjunction with two different post treatment storage time intervals, 1 h and 24 h, is shown in Fig. 7. The influence of storage time on treatment antimicrobial efficacy at shorter treatment duration of 60 s was clearly observed regardless of the mode of ACP exposure. *E. coli* populations decreased by 5.2 and 6.5 log₁₀ CFU/ml in MRD and PBS, respectively, after 60 s of direct ACP treatment and 1 h of post treatment storage time (Fig. 7a). The media effect was evident in the case of indirect ACP treatment, where the bacterial population was reduced only by 1.0 log cycle in MRD and 6.0 log cycles in PBS with post treatment storage for 1 h (Fig. 7b). Extending the post treatment storage time to 24 h nullified any media effect, with complete inactivation recorded in both media, irrespective of the mode of ACP exposure. Considering these results, the effect of further reduced treatment time (< 60 sec) on ACP inactivation efficacy was assessed using only 24 h of post treatment storage time.

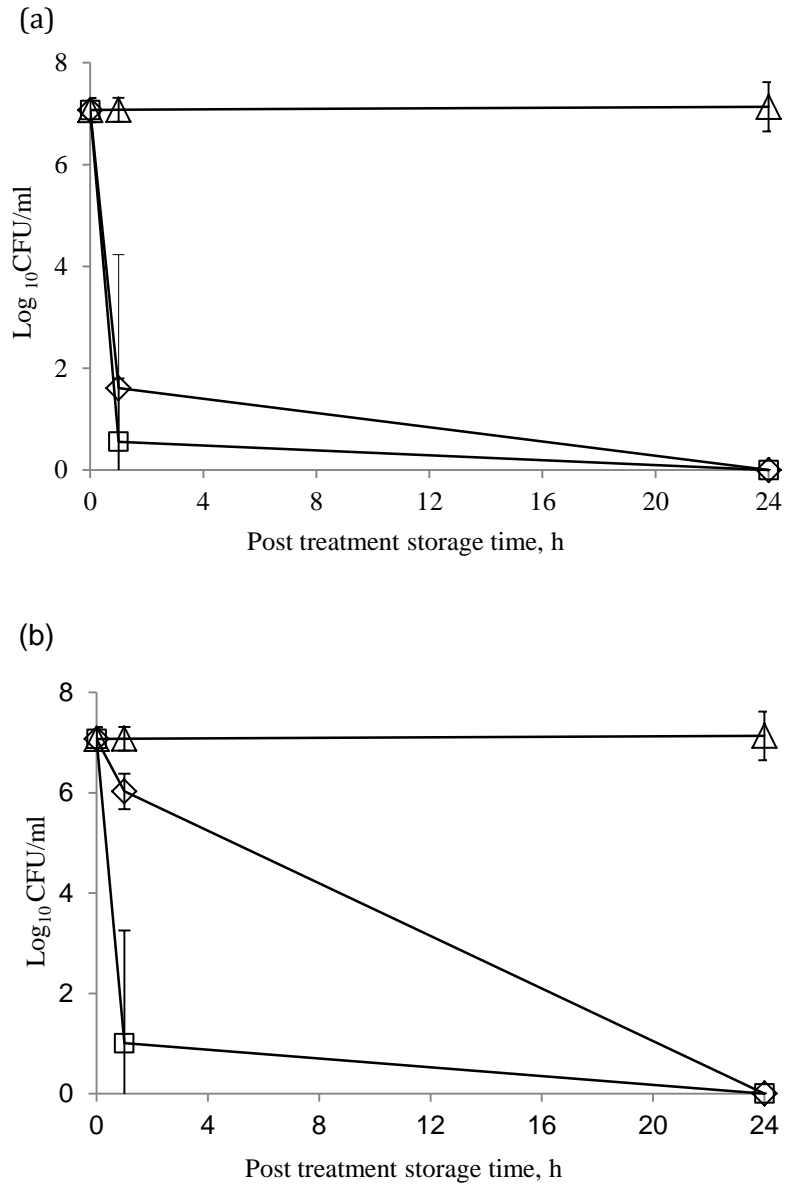

Figure 7: Effect of post treatment storage time (1 h and 24 h) on antimicrobial efficacy of ACP treatment against *E. coli*. Treatment time 60 s.

(a) direct and (b) indirect treatment: (Δ) control, (◇) MRD, (□) PBS. Vertical bars represent standard deviation.

Reducing direct ACP treatment time to 20 s resulted in inactivation of bacterial cells suspended in MRD to undetectable levels (Fig. 8a), whereas a gradual reduction of *E. coli* population in MRD was observed with respect to the treatment time using indirect ACP treatment (Fig. 8b). A significant difference in bacterial levels following indirect ACP treatment of 20 s by comparison to 45 s was noted when surviving bacterial populations are compared with the untreated controls ($P \leq 0.05$). Bacterial cells suspended in PBS were undetectable after treatment irrespective of the mode of exposure or treatment time.

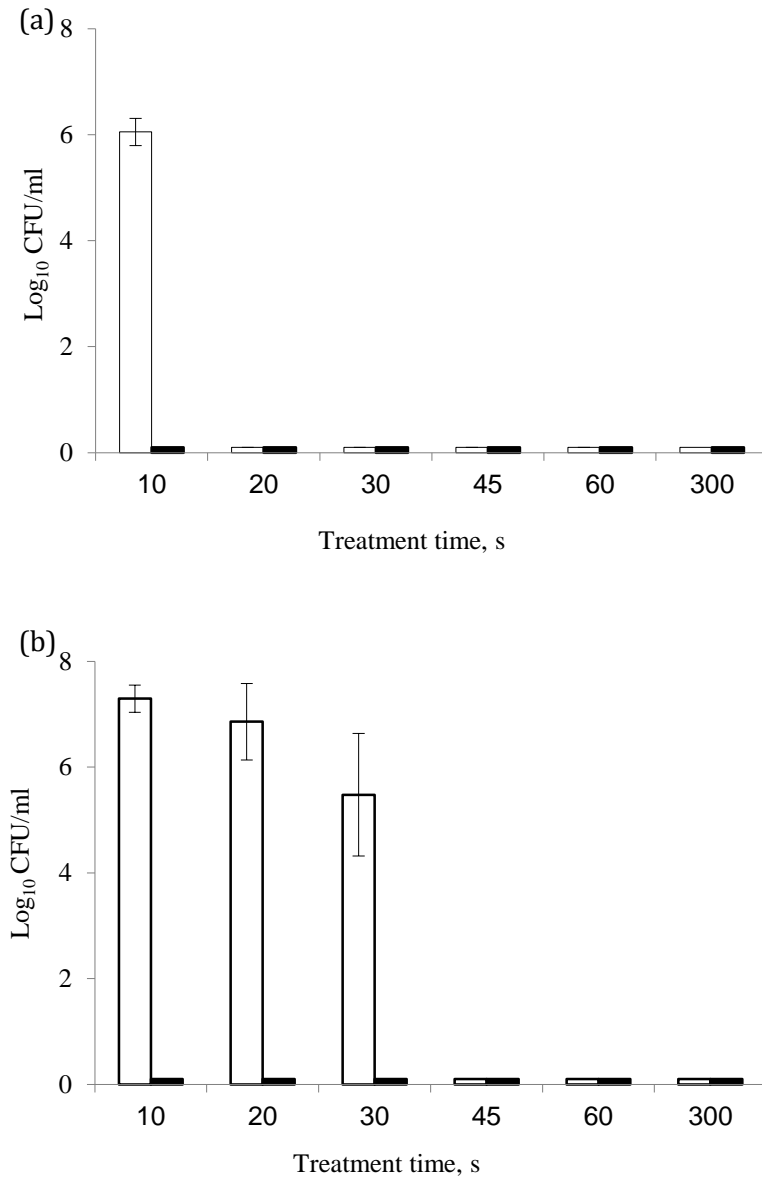

Figure 8: Effect of treatment time on ACP antimicrobial efficacy against *E. coli*.

(a) direct and (b) indirect treatment: (■) PBS, (□) MRD. Post treatment storage time 24 h. Vertical bars represent standard deviation.

3.2. Effect of voltage on ACP inactivation efficiency

The effect of increasing voltage on ACP antimicrobial efficiency in two different media and mode of plasma exposure using the two systems, DIT60 and DIT120, is shown in Fig. 9. The influence of the system type on ACP bactericidal efficiency with treatment duration of 30 s was clearly observed in case of MRD bacterial suspension. Thus, after direct 40 kVp-p treatment generated on the DIT60 populations of *E. coli* suspended in MRD were not detected. Identical inactivation efficiency was observed in case of direct 70 kV_{RMS} treatment generated on the DIT120. The least effective direct treatment was the 56 kV_{RMS} generated on the DIT120, which reduced *E. coli* population by only 1.2 log₁₀ CFU/ml. Reductions of *E. coli* populations in MRD due to indirect treatment with 40 kV p-p (DIT60) and 56 kV_{RMS} (DIT120) voltage levels were statistically insignificant, whereas 5.8 log reduction was achieved exposing the samples to the 70 kV_{RMS} of the DIT120. Again, the effect of media was evident, with complete bacterial inactivation found in PBS using either system, irrespective of the mode of exposure or voltage applied.

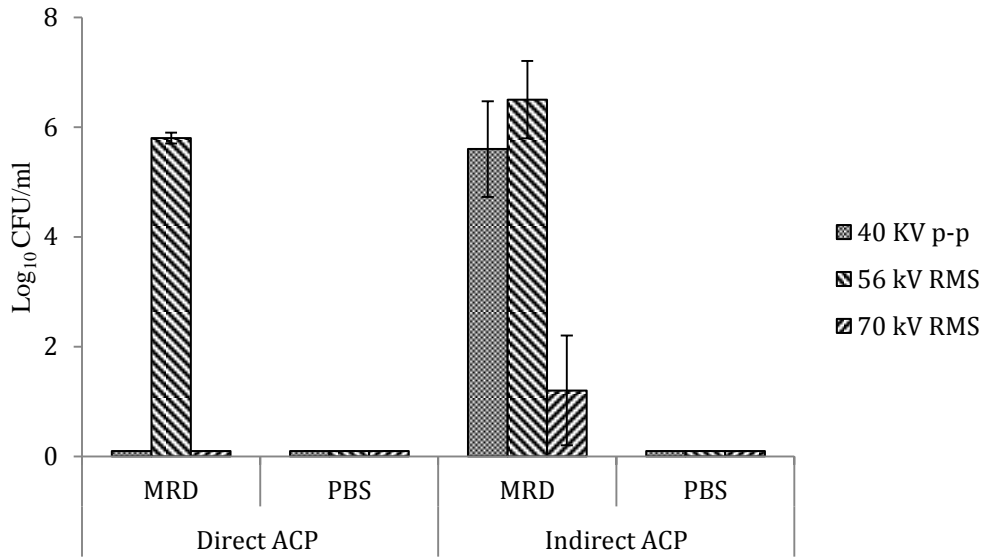

Figure 9: Effect of voltage level on ACP antimicrobial efficacy against *E. coli*. Treatment time 30 s, post treatment storage time 24 h.

Vertical bars represent standard deviation.

3.3. Effect of gas composition on ACP decontamination efficiency

The influence of gas composition in conjunction with voltage levels on ACP antimicrobial efficacy is presented on Fig. 10. In this study DIT120 system was utilised.

Figure 10(a) represents inactivation efficacy of ACP treatments with 56 kV_{RMS}. Direct ACP treatment generated from air and 90%N₂ + 10%O₂ gas mixture reduced bacterial populations in MRD by 1.2 and 0.8 log, respectively. Indirect air ACP treatment reduced the number of bacterial cells in MRD by less than 1.0 log₁₀ CFU/ml, and no reductions were observed in MRD using 90% N₂ + 10% O₂ gas mixture. Bacteria was not detected in PBS utilising either direct or indirect ACP generated from air, and a lesser inactivation effect was observed for 90%N₂ +

10%O₂ generated direct ACP. *E. coli* was not detected regardless of mode of exposure or media composition when the gas mixture with higher oxygen content (65%O₂ + 30%CO₂ +5%N₂) was utilised.

Figure 10(b) represents reductions in the number of viable cells using ACP generated at 70 kV_{RMS}. The combination of increased voltage and direct ACP treatment yielded undetectable levels of bacteria from MRD and PBS while using either gas mixture as the inducer gas. Indirect ACP generated from air and 90% N₂ + 10% O₂ gas mixture reduced bacterial populations in MRD by 6.0 log and 2.0 log respectively, whereas the gas mixture with higher oxygen content resulted in complete inactivation of bacteria in MRD. Following treatment, *E. coli* suspended in PBS could not be recovered irrespective of the gas mixture composition utilised.

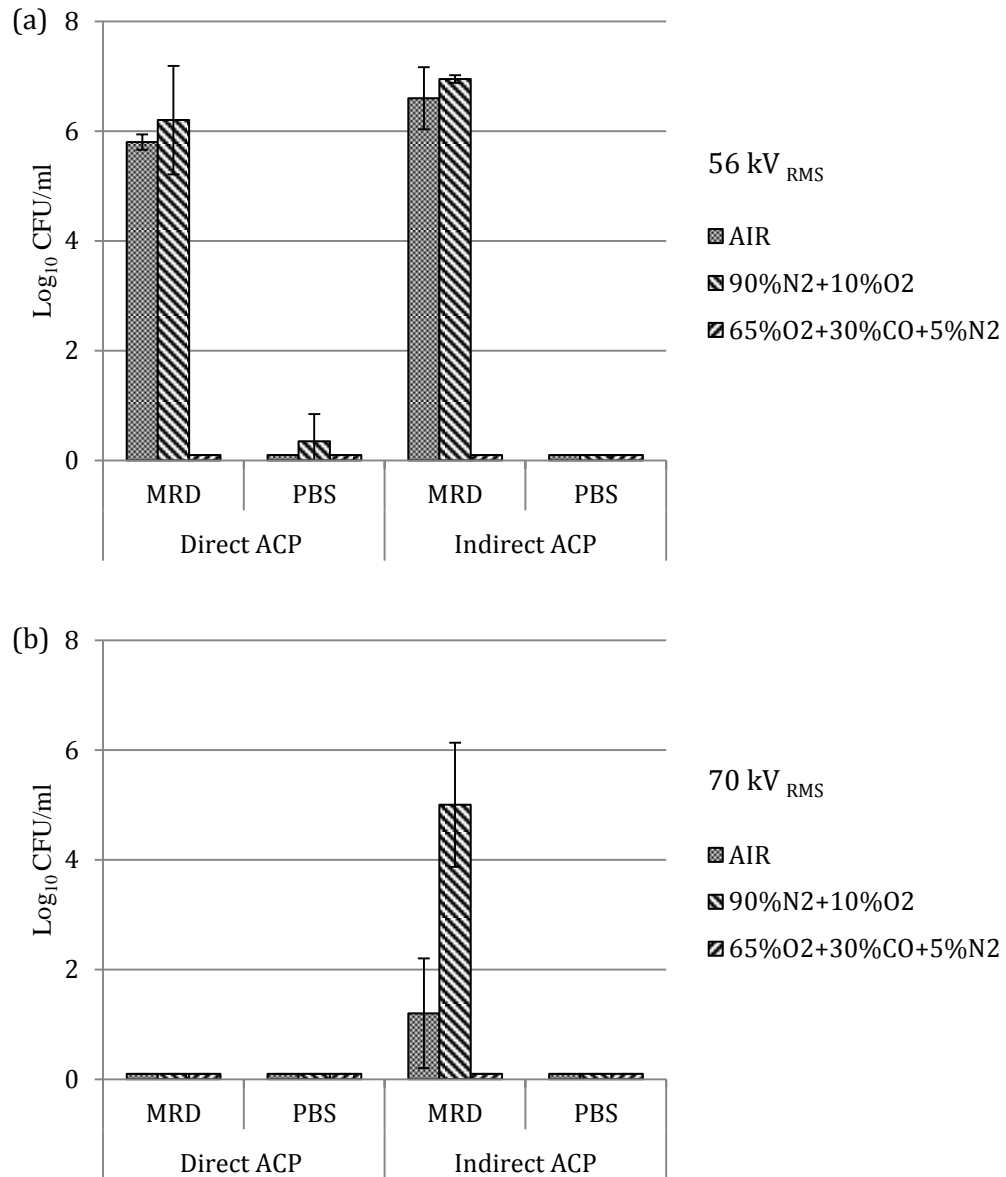

Figure 10: Effect of gas composition on ACP antimicrobial efficacy against *E. coli*. Treatment time 30 s, post treatment storage time 24 h.

(a) 56 kV_{RMS} and (b) 70 kV_{RMS}, at atmospheric air or utilising gas mixtures 90%N₂ + 10%O₂ and 65%O₂ + 30%CO₂ + 5% N₂. Vertical bars represent standard deviation.

3.4. Effect of ACP treatment on methylene blue discoloration rate

Figure 11 represents the influence of either direct or indirect mode of ACP exposure on MB discoloration rate and the inactivation of bacteria *E. coli*. As the treatment time with direct ACP increased from 0 to 30 s, degradation of MB was at 94%, whereas 100% of bacterial inactivation was achieved after 20 s of ACP exposure (Fig. 11a). However, indirect ACP treatment was less effective towards inactivation of *E. coli* comparing with MB colour reduction: 60 s of indirect ACP was required to achieve maximum reductions of both *E. coli* population and reduction of MB colour intensity (Fig. 11b).

Thus, there was no correlation found between reduced bacterial populations and MB discoloration due to either direct or indirect ACP treatment.

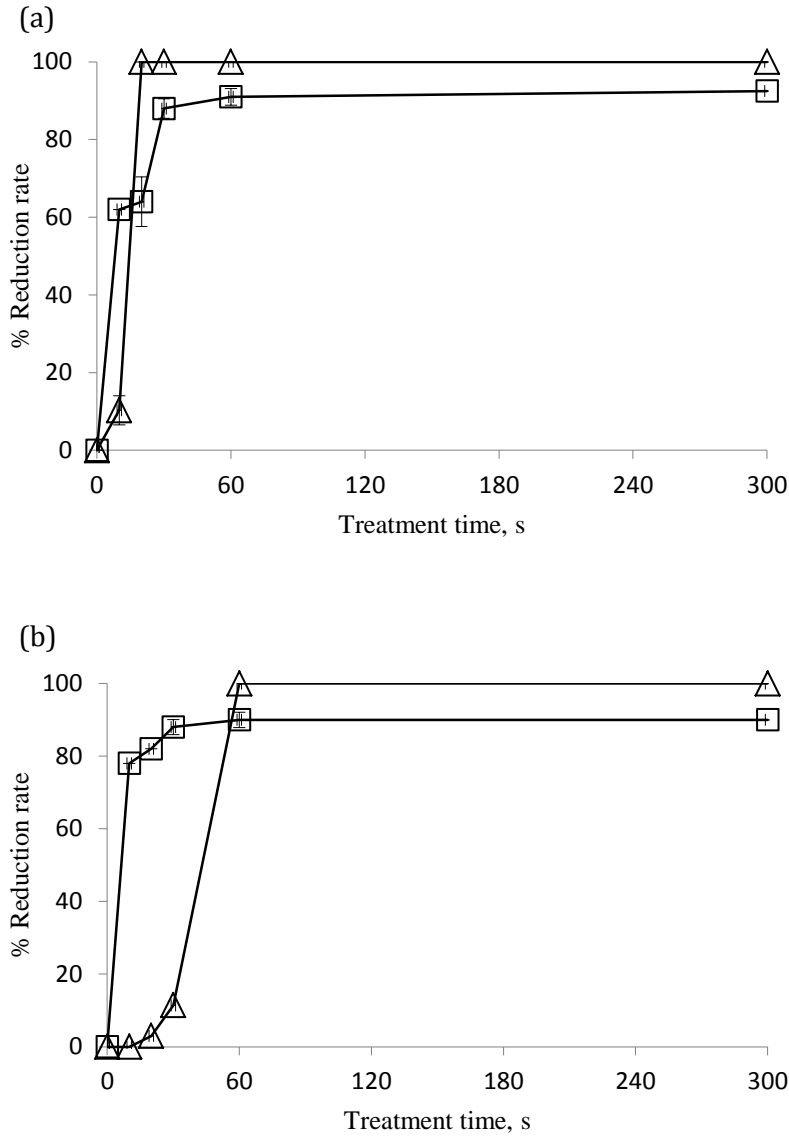

Figure 11: Effect of ACP treatment on *E. coli* and methylene blue.

(a) and indirect (b) ACP treatment; *E. coli* suspended in MRD (Δ) and discoloration of methylene blue (\square). Vertical bars represent standard deviation.

3.5. Ozone concentration measurements

The concentration of ozone was related to the ACP treatment time studied when ACP was generated on DIT60 with 40 kVp-p and atmospheric air (Table 3). Thus, immediately after 300 s of direct ACP treatment an ozone concentration of approximately 4000 ppm was recorded, with 530 ppm detected when 10 s of plasma treatment was applied ($P \leq 0.05$). However, in this study, no significant difference was observed between ozone concentrations generated after 300 s or 60 s of either direct or indirect ACP treatment.

Table 3: ACP treatment times and corresponding concentrations of ozone, measured immediately after the treatment.

ACP treatment time (s)	Ozone concentration (ppm)	
	Direct ACP	Indirect ACP
10	530 ^a	1200 ^a
20	1770 ^b	2800 ^b
30	2200 ^b	2300 ^{ab}
45	1870 ^b	3200 ^{bc}
60	4070 ^c	4400 ^{cd}
300	4100 ^c	5200 ^d

Different letters indicate a significant difference in ozone concentrations according to either direct or indirect ACP.

Figure 12 shows ozone concentrations recorded after ACP treatment of *E. coli* for 30 s generated on DIT120 and utilising either 56 or 70 kV_{RMS} and atmospheric air or different gas mixtures. Generally, higher voltage level always resulted in higher concentration of ozone generated inside container. A substantial increase in

concentration of ozone was observed when gas mixture with higher oxygen content was utilised. Thus, ozone concentrations measured immediately following 56 kV_{RMS} of air ACP ranged from 1000 to 1200 ppm after direct or indirect exposure, respectively. Increasing voltage to 70 kV_{RMS} resulted in 2400 and 2700 ppm of ozone after direct and indirect exposure, respectively. Gas mixture containing lowest amount of oxygen (10%) resulted in lower levels of ozone concentration with maximum of 1600 ppm recorded after higher voltage and indirect ACP exposure. As the oxygen content increased in the gas mixture (65%) substantial increase in concentration of ozone was noted. Thus, 56 kV_{RMS} of direct and indirect ACP resulted in 4600 and 6200 ppm and was further increased to 9000 and 9200 ppm, respectively, when 70 kV_{RMS} was utilised.

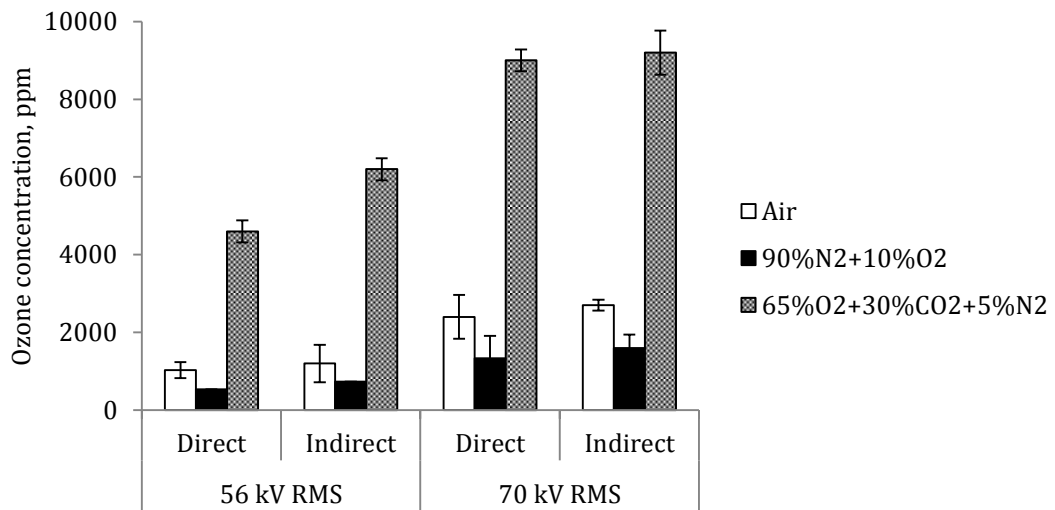

Figure 12: Generation of ozone inside a sealed package during 30 s of either direct or indirect ACP generated using different gas mixtures.

Vertical bars represent standard deviation.

3.6. Samples pH measurements

A considerable decrease in MRD pH was observed after ACP treatment with post treatment storage time of 24 h (Table 4). Direct and indirect ACP treatment for 60 s followed by 1 h of post treatment storage time reduced the MRD pH from 6.9 to 4.1 and 4.5, respectively. Direct ACP treatment time of 300 s followed by 1 h of post treatment storage reduced the MRD pH to 3.5. In contrast, insignificant decreases of pH levels in PBS were observed after extended ACP treatment (data not shown).

Table 4: Effect of direct and indirect ACP treatment accompanied with 24 h of post treatment storage on MRD pH.

ACP treatment time (s)	MRD pH	
	Direct ACP	Indirect ACP
10	4.2 ^a	4.5 ^a
20	3.8 ^b	3.9 ^b
30	3.7 ^c	3.9 ^b
45	3.4 ^d	3.4 ^c
60	3.3 ^d	3.4 ^c
300	2.4 ^e	2.9 ^d

Different letters indicate a significant difference in pH according to either direct or indirect ACP

A separate set of experiments was conducted in order to investigate the effects of low pH on bacterial survival, which showed no significant effect of lower pH values on bacterial cell proliferation (Fig. 13).

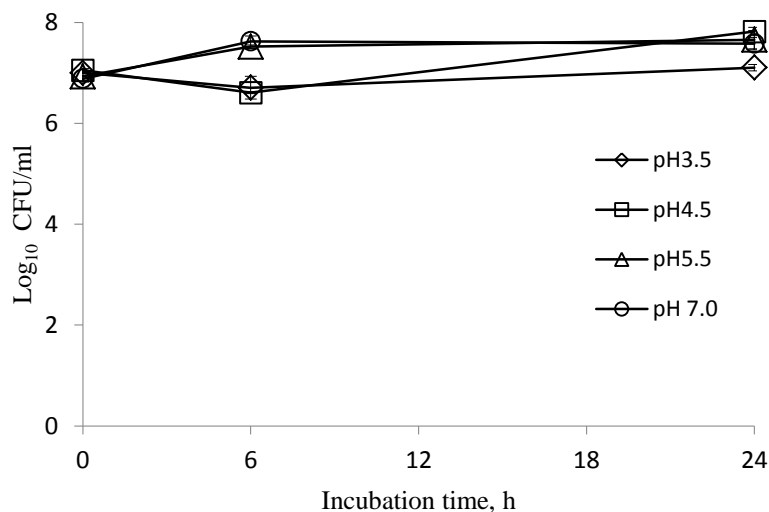

Figure 13: Effect of MRD acidic pH on proliferation of *E. coli*.

pH level was adjusted with 0.1 M HCl. Inoculated MRD samples were incubated at room temperature for 0 h, 6 h and 24 h.

3.7. SEM analysis

SEM images of DBD ACP treated and untreated *E. coli* cells are shown in Fig. 14. Smooth bacterial cells were observed in *E. coli* samples before plasma treatment (Fig. 14a). Following 30 s of either direct or indirect plasma treatment (Fig. 14b,c, respectively) the cells morphology was changed compared to the untreated cells. Most of *E. coli* cells exhibited surface roughness, indentations and small fractions of cells have either been deformed (arrows 1) or developed holes on their surface (arrows 2). Overall, DBD-ACP treated cells appeared to be shrunken and dehydrated.

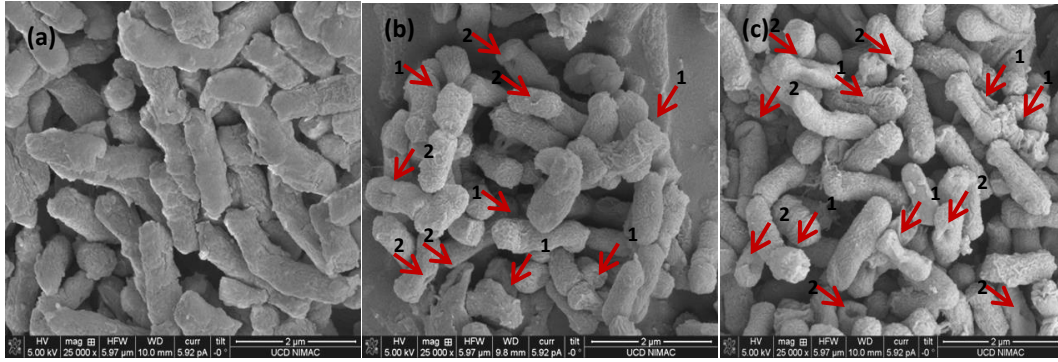

Figure 14: SEM images of *E. coli* treated with ACP for 30 s and stored for 24 h.

(a) untreated (b) direct and (c) indirect ACP treatment.

3.8. Optical Emission Spectroscopy (OES)

Emission spectrum of the filamentary discharge in air at 40 kV over the range of 180 to 900 nm is presented in Fig. 15. Most of the distinct peaks obtained in the near UV region corresponded to strong emissions from N_2 and N_2^+ excited species, which was previously reported by Machala *et al.* (2007). However, the major peaks of active oxygen could not be identified on the light emission spectra, probably because active oxygen with relatively long life-time tend to lose energy due to particle collisions, quenching its energy before detectable light emissions at the end of its life-time.

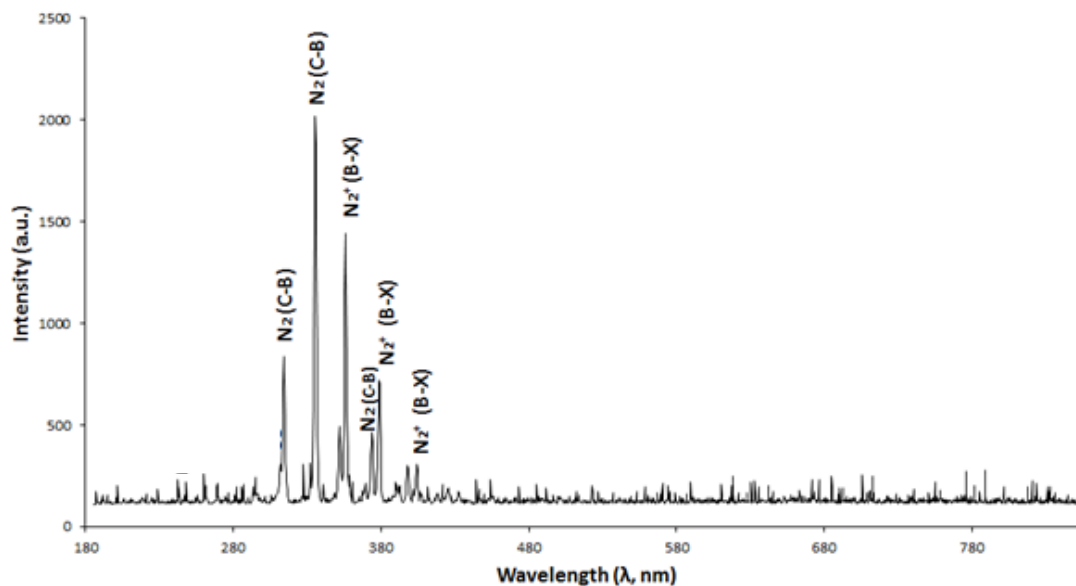

Figure 15: Emission spectrum of DBD ACP operating in air under atmospheric pressure.

3.9. Discussion

ACP treatment was effective for inactivation of *E. coli* in liquids. In some cases, the extrinsic parameters studied, such as treatment time, post treatment storage time, position of the samples with respect to the plasma discharge, and liquid media used, had a significant influence on plasma inactivation efficacy. Additionally, the placement of the samples in either direct or indirect exposure to the ACP had a strong influence on the antimicrobial efficacy of the system in conjunction with other parameters. Generally, use of direct ACP treatment was more effective for bacterial inactivation than indirect. The possible explanation for this effect could be that the samples were located directly between the electrodes under plasma discharge and were thus exposed to all generated reactive species, such as charged particles, positive and negative ions, electrons, free radicals,

excited and non-excited molecules and atoms, heat and UV photons. In contrast, when the samples were exposed to indirect ACP treatment, i.e. at some distance from plasma discharge, the charged particles did not affect the sample directly during treatment. This could be attributed to the charged particles recombining before reaching the sample; therefore, only long-lived radicals had an effect on the biological sample (Laroussi 2009). However, indirect plasma treatment has also achieved useful bacterial inactivation levels. Rod *et al.* (2012), utilising a similar DBD plasma device and indirect treatment of ready to eat sliced meat, demonstrated 1.6 log bacterial reductions. Moreover, the use of indirect exposure of plasma discharge may prove beneficial for adoption of this technology to the widest range of possible uses in the food industry where a balance between maintaining quality characteristics of sensitive fruits and vegetables and microbial decontamination is required.

Consistent microbial inactivation was achieved with 300 s and 60 s of treatment time with either direct or indirect ACP modes of exposure. However, interactive effects of post treatment storage time and liquid media were noted.

Post treatment storage time emerged as a critical treatment parameter for consistency of bacterial inactivation with this system. The interactions between plasma and bacteria suspended in liquids have been reported in a number of studies (Tang *et al.* 2008; Ikawa *et al.* 2010; Julak *et al.* 2012). This complex interaction is generally based on the diffusion of plasma generated reactive species into the liquids (Oehmigen *et al.* 2010). Plasma generated from air is characterised by various chemically reactive species, with the main role given to ozone as the most

long-living and most oxidative species (Klockow and Keener 2009). Gaseous ozone has high penetrability and after contact with liquids forms residual ozone and continues to effect microbial cells (Mukhopadhyay and Ramaswamamy 2012). In this study the diffusion of reactive species into liquids during post treatment storage and the influence of this diffusion on DBD ACP bactericidal efficacy were examined. Complete inactivation of bacterial cells during the prolonged post treatment storage time demonstrated that the storage of samples facilitated diffusion of the generated species into the liquids with accompanying antimicrobial action on the cells. The half-life of the species generated will govern whether that species will have sufficient time for diffusion to occur. Species with very short half-lives will not have sufficient time for diffusion; consequently, it is likely that the inactivation observed in this case is due to the relatively long lived species.

A reduced treatment time (60 s) in conjunction with 24 h of post treatment storage time also showed an enhanced plasma inactivation effect indicating penetration of available reactive species into the samples and leading to complete bacterial inactivation. Although significant bacterial reductions were also achieved with 60 s of direct treatment time and 1 h of post treatment storage, large variations in the results were noted. Possibly, the composition of the chemically reactive species generated and/or their concentrations within the container are not identical at each plasma application, which may be more apparent when very short treatments are applied in conjunction with a short post treatment storage time.

The concentration of ozone was monitored at all stages of sampling in this study and it was noted that the ozone concentrations after either direct or indirect air

ACP treatment for 300 s and 60 s did not differ significantly. The reliability of inactivation efficacy achieved with 24 h post treatment storage is a useful observation for practical application to products or systems. It is probable that a range of other antimicrobial species in addition to ozone may also influence plasma inactivation efficiency. Previously, RNS were reported to be mainly responsible for the formation of nitrates and nitrites in the liquid media by reacting with media components, such as organic acids and proteins (Fernandez and Thompson 2012), thus changing the media pH towards acidic range, which enhanced plasma bactericidal efficacy (Burlica *et al.* 2006; Ikawa *et al.* 2010; Liu *et al.* 2010). This effect of reduced pH was further investigated by Oehmigen *et al.* (2010), which experimentally confirmed the role of RNS in liquid acidification by ACP, and clearly showed media pH dependent reductions of the number of viable microorganisms. ACP generated hydrogen peroxide in liquids was also reported to have an inhibitory effect on the bacterial cells (Joshi *et al.* 2011). The questions remain, that with the wide range of potential reactive species that can result with varying plasma generation conditions whether they have differing intensity of antimicrobial effect, varying roles in the mode of efficacy or indeed if the effects cannot be separated and are to be concluded as complimentary to antimicrobial efficacy. These are key areas for future study to ensure that the extrinsic parameters for plasma generation conditions can be optimally applied for product decontamination and antimicrobial efficacy.

To investigate the complexity that might be present in a range of products (e. g., organic acids, proteins, amino acids, which can interact with plasma reactive

species) to which this type of non-thermal technology might be applied, a preliminary study, using two simple media PBS and MRD, was warranted. A strong effect of media composition, which was also related to the mode of plasma exposure was noted at reduced plasma treatment times, where only 24 h of post treatment storage was applied. Direct plasma treatment of 20 s provided inactivation of bacteria to undetectable levels in both media. However, with indirect plasma treatment below 45 s effects of media type became apparent: as treatment time was reduced from 30 s to 20 s, the inactivation efficacy decreased, and no reductions in the number of viable cells were observed after 10 s of indirect plasma treatment in MRD. However, in PBS, which has a simpler composition than MRD, complete bacterial inactivation using either direct or indirect plasma treatment was recorded at all of the treatment times studied. Conversely, for samples exposed to longer treatment time (300 s), greater antimicrobial efficiency was recorded in MRD by comparison with PBS. Possible explanation for these trends in inactivation efficacy with respect to media composition could include effects of pH and the type and concentration of active species present at the same treatment conditions in the different media. With respect to the possible effect of pH, inactivation was correlated with a pH decrease. Additionally, the results obtained from OES point to the fact that air ACP is a significant source of RNS and this in turn could cause acidification of MRD. MRD is mainly composed of sodium chloride and low concentrations of peptone. Although the concentration of peptone is low, it may interact with plasma generated RNS, resulting in a significant reduction of MRD pH, thereby enhancing plasma inactivation

efficiency in the case of extended treatment time (300 s). When samples were exposed to shorter treatment times (< 60 s), the MRD pH was less affected. The relationship between treatment time and resulting sample pH on inactivation efficacy may be closely linked in the case of more complex media and should be carefully considered in any application study. When the effect of acidic pH on survival of *E. coli* was assessed independently of ACP treatment, it showed no significant effect on the rate of bacterial inactivation. This confirmed that bacterial inactivation was a result of ACP exposure, and it may be due to a possible synergistic effect of an acidic MRD environment in combination with plasma generated reactive species. In contrast, PBS is a buffered solution mainly composed of sodium chloride and phosphates where pH changes are minimal in response to addition of either strong acid or base. The ACP bactericidal effect in PBS at very low treatment times might be due to specific reactions occurring between the plasma species and sodium chloride, as a main constituent of PBS, altering it to a more bactericidal structure. Recent investigations of ozonated saline solution for medicinal uses, which is relatively close to the chemical composition of PBS, pointed out that in the presence of ozone, hypochlorous acid, even if in trace amounts, will also be generated. Hypochlorous acid is known as an excellent bactericidal compound which can exert a deleterious reactivity with protein groups, aminogroups, with DNA, RNA, and lipids (Bocci *et al.* 2011).

The influence of the voltage levels on ACP inactivation efficacy was investigated utilising different DBD systems. The two systems DIT60 and DIT120 and application of 40 kV peak to peak or 56 kV_{RMS}, respectively, appeared to be

different, where DIT60 showed greater reductions in microbial population than DIT120. A possible explanation for this could be the different distribution of the output voltage between the two electrodes: DIT60 has an equal output voltage between ground and top electrodes, whereas DIT120 output voltage is concentrated on the top electrode only with zero voltage on the ground electrode. Overall, increased voltage from 40 kV to 70 kV was the most effective for eliminating the tested microorganism. These results suggest that voltage level should be considered as one of the main ACP efficacy determining parameter, which is in agreement with the previously published reports (Song *et al.* 2009; Kim *et al.* 2011; Frohling *et al.* 2012a; Suhem *et al.* 2013).

When atmospheric air was compared with two gas mixtures for generation of ACP, it was observed that antimicrobial capacity of treatment was lower with plasma generated from the gas with higher nitrogen content (90% N₂ + 10% O₂), than with an air or high oxygen content gas mixture (65% O₂ + 30% CO₂ + 5% N₂), which is in agreement with other published studies (Yang *et al.* 2010; Niemira 2012b). *E. coli* could not be recovered regardless of mode of exposure or media composition when gas mixture with higher oxygen content (65% O₂) was utilised. This may be attributed to the production of higher amounts of cytotoxic ozone and other oxygen-based reactive free radicals during the breakdown of the gas mixture (Rowan *et al.* 2007; Fernandez and Thompson 2012). Considerable increase in inactivation efficacy was observed when either working gas was used for generation of ACP at high voltage of 70 kV_{RMS}. Direct treatment and increased voltage resulted in reduction of bacteria to undetectable levels in either media or

gas composition utilised. Mode of plasma exposure did not influence ACP antimicrobial efficiency when a gas mixture with higher oxygen content was utilised, resulting in inactivation of bacteria in either media examined.

The potential for air ACP to produce highly reactive oxygen species was proven in the study when aqueous solution of a model basic textile dye, MB, was used as potential indicator of the efficacy of ACP treatments. Ozone generation is one of the major applications of ACP and ozone is an excellent agent for the discoloration or treatment of wastewater (Reddy *et al.* 2013). It is known that MB undergoes oxidative reaction, where ozone and other oxidants react with unsaturated functional groups present in organic molecules, and the colour as a result degrades (Grabowski *et al.* 2006). In this study, as the treatment time increased, the colour of the MB solution decreased from dark blue to almost colourless in the presence of plasma reactive species. Moreover, increased ozone concentration always resulted in the increased MB degradation. Discoloration of MB was studied by Huang *et al.* (2010) and Grabowski *et al.* (2006), which demonstrated that the presence of ACP generated ozone and other oxidants are the key factor responsible for the dye degradation process. Therefore, this MB degradation was mainly attributed to the reaction of ozone and possibly other ROS produced by ACP, which diffuse into the liquid phase of a dye, where they react with the dye molecules. The extent of discoloration was greater for dye samples treated directly than those treated indirectly, which was also observed for the bacterial samples. The difference was statistically significant ($P \leq 0.05$) for treatment times ranging between 20 s and 90 s. This difference could be explained on the basis of

difference in the diffusion and absence of short half-life metastable species (such as O_2^- , OH^+ , N_2^+ , N_2O^+ etc.) during indirect exposure. When indirectly treated, the charged particles and short-lived species do not affect the sample under treatment as they recombine before reaching it. This leaves mainly the long-lived reactive species (such as O_3 , O_2 , NO_2 , NO , CO) to directly interact with the sample (Laroussi 2009). Overall, these results demonstrated ACP potential to degrade organic dye MB, however, no strong correlation between bacterial reduction and MB discoloration was noted.

In order to further our understanding of the inactivation mechanism, SEM analysis was performed on *E. coli* cells treated directly and indirectly with air ACP for 30 s in MRD and subsequently stored for 24 h prior to SEM preparations. SEM images demonstrated that ACP treated cell surface were altered or dehydrated as cells exhibited a shrunken morphology, but visually no cell lysis was observed. It was previously reported that ozone treated *E. coli* cells remain intact and cell lysis is not the major mechanism of bacterial inactivation (Patil *et al.* 2011). The possible bactericidal action of ACP is more likely based on the diffusion of plasma generated reactive species through the cell membrane into the cell where they react and possibly damage proteins and nucleic acids leading to cell death. However, further studies are needed to get clearer insights into the mode of action of ACP, the effects of ACP generated species on cellular components, and the chemistry involved in liquids mediated by those species.

3.10. Conclusion

The inactivation efficiency of the DBD ACP system used in this study was affected by the mode of exposure, treatment time, post treatment storage time, voltage levels, working gas and media composition. There were also interaction effects between these parameters; however, an average of 7.0 log₁₀ CFU/ml reduction of *E. coli* population was recorded in the more complex media with direct ACP treatment for 20 s generated on DIT60 in conjunction with a post treatment storage time of 24 h. Increasing the voltage to 70 kV_{RMS}, which was possible with DIT120, was more effective for microbial inactivation in MRD: *E. coli* population was inactivated after 30 s of the direct treatment and reduced by 5.9 log cycles after 30 s indirect ACP of treatment. Again, the effect of media was evident, with complete inactivation recorded in PBS using either system, irrespective of the mode of exposure or voltage applied. Inactivation efficacy of ACP increased when gas mixture with high oxygen content (atmospheric air and 65% O₂ + 30% CO₂ + 5% N₂) for generation of plasma was utilised, nullifying the effect of process parameters of voltage, mode of ACP exposure and media composition.

Despite the varying parameters that influenced plasma bactericidal activity, the novel high voltage either direct or indirect in-package atmospheric air generated ACP decontamination approach showed an efficient reduction of high concentrations of *E. coli* in liquids under both direct and indirect treatment modes. According to these favourable results for sealed package, ACP demonstrates a significant technological advance in non-thermal, bactericidal treatment of materials.

Chapter 4: ACP DECONTAMINATION OF FRESH PRODUCE

According to the treatment optimisation studies, optimum parameters of DBD ACP generated on the DIT120 system, namely mode of exposure, post treatment storage time, voltage level and type of gas were determined and selected for further investigations. Importantly, it has been demonstrated that indirect mode of ACP treatment was very effective in bacterial inactivation. Moreover, this type of treatment could be beneficial for the widest range of possible applications in the food industry where both effective microbial decontamination and quality maintenance are achieved.

The objective of this study was to evaluate the efficacy of indirect air based DBD ACP generated inside a sealed package against common foodborne pathogens, *E. coli*, *Salmonella* and *L. monocytogenes*, inoculated on cherry tomatoes and strawberries and to evaluate its efficacy to reduce background microflora present on cherry tomatoes and strawberries in order to increase the produce shelf life. Generally, indirect ACP treatment with subsequent 24 h of storage effectively reduced the numbers of microorganisms on either produce surface studied. On cherry tomatoes, treatments for 10 s, 60 s, and 120 s reduced populations of *Salmonella*, *E. coli* and *L. monocytogenes* to undetectable levels, respectively. However, an extended treatment time of 300 s was necessary to reduce bacterial populations attached on the more complex surface of strawberries.

4.1. Inactivation of bacteria on cherry tomatoes

The influence of ACP treatments on viability of *E. coli*, *Salmonella* and *L. monocytogenes* is represented in Fig. 16. Tomato samples were inoculated with an average of 3.1 log₁₀ CFU/sample for *E. coli*, 6.3 log₁₀ CFU/sample for *Salmonella* and 6.7 log₁₀ CFU/sample for *L. monocytogenes*. After treatment for 10 s and longer, *Salmonella* populations on tomato were undetectable. Treatment for 45 s reduced populations of *E. coli* and *L. monocytogenes* by 2.0 and 4.5 log₁₀ CFU/sample, respectively. Further increasing treatment time from 45 to 60 s reduced populations of *L. monocytogenes* by 5.1 log₁₀ CFU/sample and reduced populations of *E. coli* to undetectable levels. Populations of *L. monocytogenes* were reduced to levels below detection limits after extended treatment for 120 s.

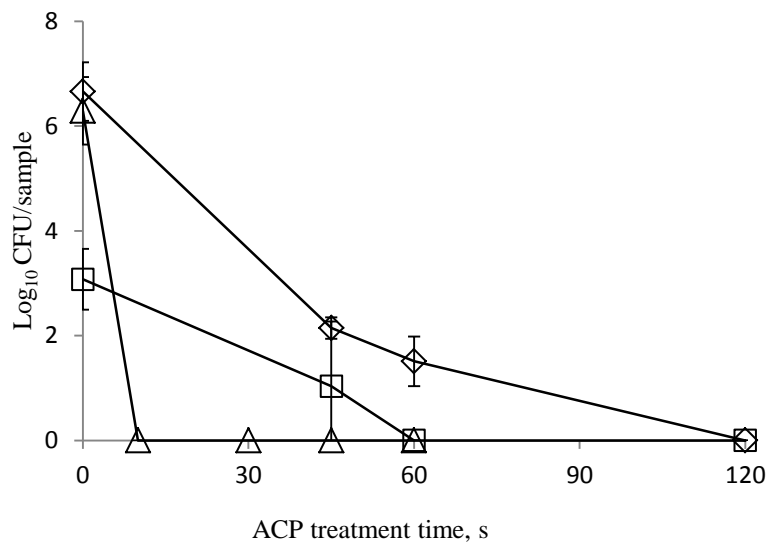

Figure 16: ACP inactivation efficacy against bacteria inoculated on cherry tomatoes.

E. coli (□), *Salmonella* (Δ) and *L. monocytogenes* (◇). Vertical bars represent standard deviation.

4.2. Inactivation of bacteria on strawberries

Reductions of *E. coli*, *Salmonella* and *L. monocytogenes* inoculated on strawberries are represented on Fig. 17. The average initial attached population of *E. coli*, *Salmonella* and *L. monocytogenes* was 4.4, 6.6 and 7.3 log₁₀ CFU/sample, respectively. After 60 s and 120 s of ACP treatment populations of *E. coli* were reduced by 1.2 and 1.6 log₁₀ CFU/sample, respectively, with significant different reductions of 3.5 log₁₀ CFU/sample achieved after treatment for 300 s ($P \leq 0.05$). Similarly, after ACP exposure for 120 s and 300 s, populations of *Salmonella* were reduced by 1.7 and 3.8 log₁₀ CFU/sample, respectively. No significant difference in antimicrobial efficacy of ACP treatments for either 120 s or 300 s against *L. monocytogenes* was observed where average reductions of approximately 4.2 log₁₀ CFU/sample were recorded. No changes were noted in the levels of bacterial populations attached on the untreated control tomato or strawberries samples after storage for 24 h.

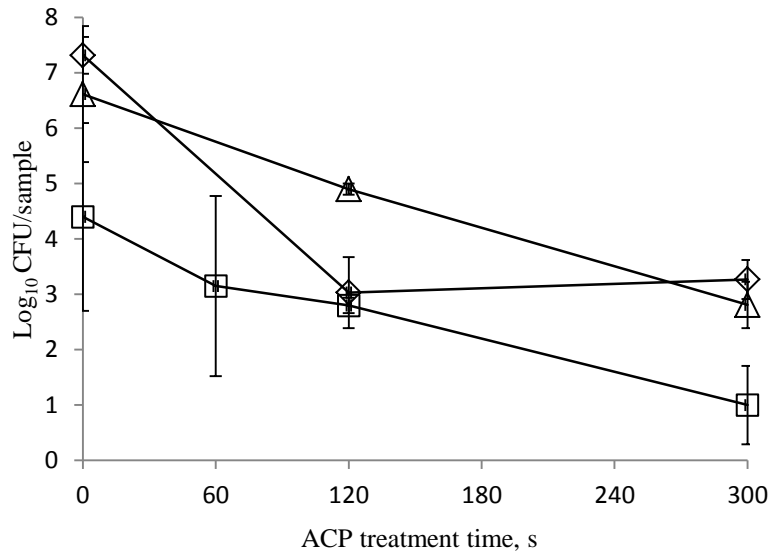

Figure 17: ACP inactivation efficacy against bacteria inoculated on strawberries.

E. coli (□), *Salmonella* (Δ) and *L. monocytogenes* (◇). Vertical bars represent standard deviation.

4.3. Inactivation of background microflora on produce

The reductions of background microflora on cherry tomatoes and strawberries due to indirect ACP treatments are represented on Fig. 18.

An average of initial background microflora on cherry tomatoes was 5 log₁₀ CFU/sample (Fig. 18a). After 60 s of ACP treatment the aerobic mesophilic counts were reduced by 3.0 log₁₀ CFU/sample, while yeasts and moulds were reduced by 2.5 log₁₀ CFU/sample. Further increase in treatment time to 120 s resulted in reduction of yeasts and moulds to undetectable levels, while population of mesophilic bacteria was reduced by 4.2 log₁₀ CFU/sample. Mesophilic bacteria were not detected when the treatment time was increased to 300 s. Untreated samples stored for 24 h showed no changes in the growth levels of background microflora on tomato samples.

Lower reduction levels of spoilage microorganisms by ACP treatment were observed in the case of strawberry samples (Fig. 18b). Significant decrease in mesophilic counts was observed after 60 s of ACP treatment, resulting in reductions by 1.6 log₁₀ CFU/sample ($P \leq 0.05$) from the control 3.6 log₁₀ CFU/sample. Populations of mesophilic bacteria did not decrease further when treatment time was extended from 60 s to either 120 s or 300 s. Populations of yeasts and moulds initially present on strawberries were 5.5 log₁₀ CFU/sample. These levels decreased by 1.0 log₁₀ CFU/sample after 120 s of ACP treatment. Extending the treatment time from 120 s to 300 s resulted in an additional 0.4 log reduction in the population of yeasts and moulds. It should be noted that the levels of mesophilic bacteria of untreated control strawberry samples increased by 1.8 log₁₀ CFU/sample during 24 h storage, whereas populations of yeasts and moulds remained the same.

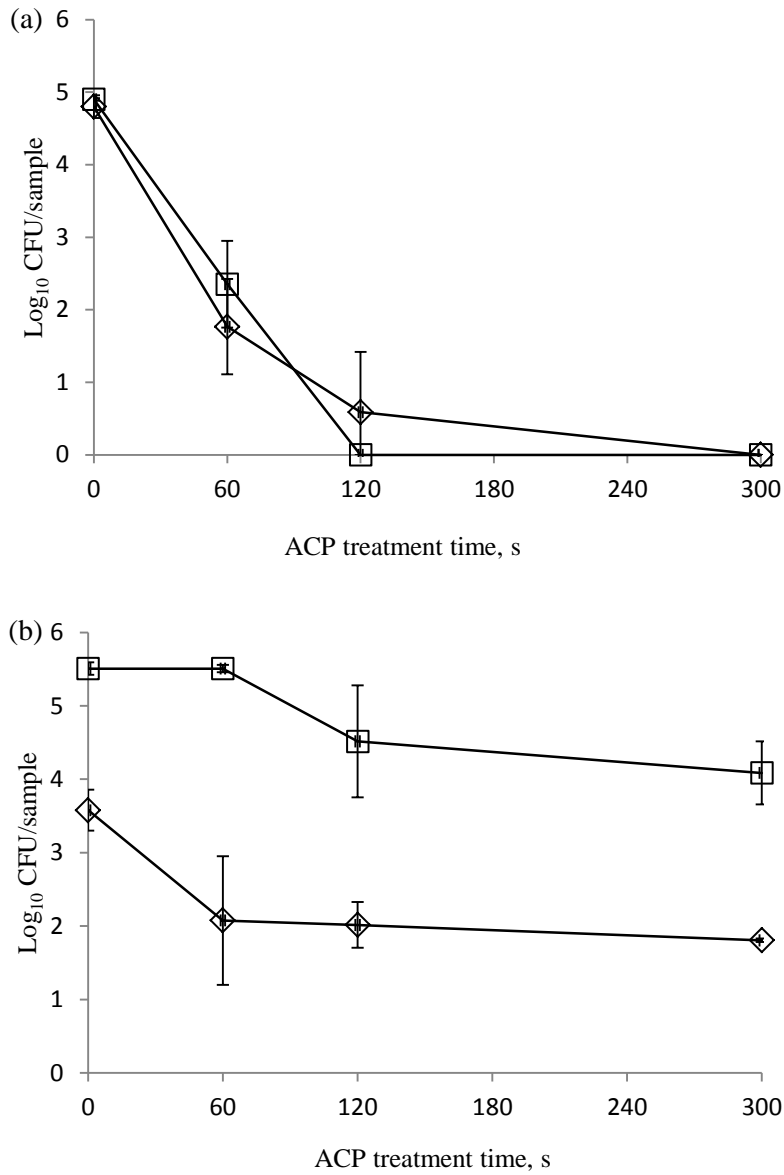

Figure 18: ACP inactivation efficacy against background microflora of produce.

aerobic mesophilic bacteria (◇) and yeasts and moulds (□) on (a) cherry tomatoes and (b) strawberries. Vertical bars represent standard deviation.

4.4. Ozone generation

Generation of ozone inside the sealed package containing either cherry tomatoes or strawberry samples as a function of ACP treatment time is represented in Fig. 19. The ozone concentration inside the package containing cherry tomatoes increased gradually in line with treatment duration. All ACP treatment times studied resulted in significant increase of ozone concentration ($P \leq 0.05$) with maximum concentration of 5600 ppm achieved after 300 s of treatment. However, no significant difference in ozone concentration generated during the treatment of strawberry samples was observed. ACP treatment for 60 s resulted in an average of 2800 ppm, and further increasing treatment time from 60 s to 120 and 300 s resulted in an average of 3200 and 3500 ppm of ozone, respectively.

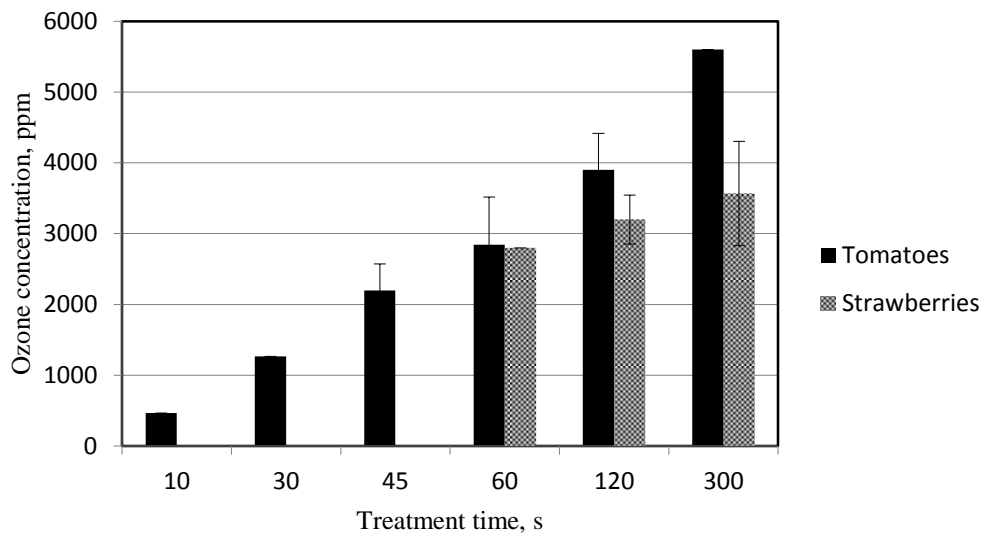

Figure 19: Generation of ozone inside a sealed package during ACP treatment of produce.

Vertical bars represent standard deviation.

4.5. SEM analysis

In order to examine if the complex substrate surface features had any effect on the bacterial adherence, and thus effect antimicrobial efficacy of ACP treatment, SEM analysis of untreated *E. coli* and *L. monocytogenes* inoculated on produce surface was conducted. Figures 20(a) and 20(b) represents the surface of the strawberry and tomato, respectively, inoculated with *L. monocytogenes* where strong bacterial attachment in the form of clusters was noticed. On the contrary, only a small amount of individually attached bacterial cells of *E. coli* on the rough surface of strawberry was found (Fig. 19c).

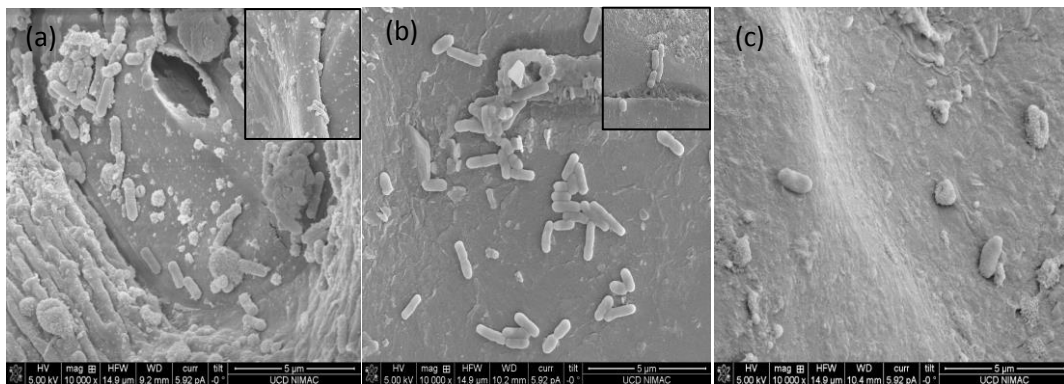

Figure 20: SEM images of untreated bacteria inoculated on produce.

L. monocytogenes on (a) strawberries (b) and cherry tomatoes, and (c) *E. coli* inoculated on strawberry.

4.6. Discussion

The indirect ACP treatment showed better inactivation efficacy against inoculated challenge bacteria and background microflora present on the surface of the two different products tested. Cherry tomatoes were selected as they have been

associated with recent foodborne illness outbreaks and represent common raw food ingredients of commercial salads. Strawberries are also popular fruits and consumed raw. Moreover, these produce types present different surface decontamination challenges to the ACP system, i.e. tomato surface which is smooth, and the more complex surface of strawberry - uneven with numerous seeds.

In general, higher inactivation rates due to ACP treatment were achieved for bacteria inoculated on smooth surface of tomatoes. *Salmonella* and *E. coli* were more rapidly inactivated on tomato than *L. monocytogenes*. Among the three bacteria studied, *Salmonella* was the most sensitive to ACP, where 10 s of treatment duration reduced bacterial population to undetectable levels. For tomato, increasing treatment time enhanced the inactivation efficacy of ACP in the case of *E. coli* and *L. monocytogenes*. Increasing treatment time from 45 s to 60 s inactivated *E. coli* populations present on tomatoes, whereas inactivation of *L. monocytogenes* to undetectable levels was only obtained after an extended time of 120 s. It is reported that Gram-positive bacteria are more resistant to ACP treatments than Gram-negative (Montie *et al.* 2000; Lee *et al.* 2006; Ermolaeva *et al.* 2011; Frohling *et al.* 2012a), which was also clearly demonstrated in the current study. *Salmonella* and *E. coli* are Gram-negative bacteria with a thinner outer membrane compared to the Gram-positive *L. monocytogenes*. The thicker membrane of the Gram-positive bacteria may present a barrier to the diffusion of plasma reactive species through the bacterial cell wall, thus impacting antimicrobial efficacy. On the contrary, Fan *et al.* (2012) revealed greater

sensitivity of Gram-positive *L. innocua* than Gram-negative *Salmonella* and *E. coli* inoculated on tomato surface. Interestingly, other comparative studies reported similar susceptibility between Gram-positive and Gram-negative bacteria to ACP with respect to inactivation (Kostov *et al.* 2010; Olmez and Temur 2010; Klampfl *et al.* 2012). Clearly, the target cell characteristics are important factors for inactivation efficacy, but no clear trend is apparent and complex interactions with the system, process, surface or medium may also impact on efficacy in combination with cell type.

In this study we observed that the difference in the initial levels of the attached bacterial populations complicates the comparison of the bacterial sensitivity to the ACP treatments based on bacterial cell membrane characteristics. It is widely accepted that high initial bacterial concentration may affect inactivation efficacy of plasma treatment. The study conducted by Fernandez *et al.* (2012) clearly demonstrated that increasing the concentration of *S. Typhimurium* from 5 to 8 log₁₀ CFU/filter reduced the inactivation efficiency of ACP. Similarly, Baier *et al.* (2013) demonstrated reduced bacterial susceptibility to ACP treatment with increased initial bacterial concentration, suggesting that the initial concentration of microorganisms present on foods plays an important role in the efficacy of plasma treatment. In the present work, the lower initial populations of *E. coli* attached on tomatoes surface did not necessarily contribute to the increased ACP bactericidal characteristics. Within 45 s of treatment populations of *E. coli* were reduced by 2 log from the initial 3.1 log₁₀ CFU/sample, whereas this treatment time resulted in the reductions of *L. monocytogenes* populations by 4.5 log from the initial 6.7 log₁₀

CFU/sample, and only 10 s was required to reduce *Salmonella* by 6.3 log₁₀ CFU/sample. This indicates the importance of the mechanisms and strengths of bacterial attachment with respect to a decontamination procedure. It has also been demonstrated that the resistance to ACP may also vary between bacteria species. Despite the higher inoculation levels on tomato surface, *Salmonella* appeared to be more sensitive than *E. coli*. Similar results were achieved in the research conducted by Niemira and Sites (2008) where *Salmonella* Stanley was more sensitive to ACP than *E. coli* inoculated on both agar and apple surfaces.

The influence of the produce type on the overall antimicrobial efficacy of ACP was observed when results are compared with the strawberry decontamination study. Treatment for 120 s significantly reduced *L. monocytogenes* inoculated on strawberries. Increasing treatment time to 300 s did not yield any further reductions of bacteria. However, after 300 s of treatment, a proportional reduction of *E. coli* and *Salmonella* was achieved. Strawberry surface is more porous than the surface of tomato. Irregularities of the fruit surface may provide many niche areas for bacteria, providing physiological barrier or protection against ACP treatments. This factor probably contributed to the reduced ACP bactericidal effect on Gram-negative bacteria on strawberries by comparison with tomatoes.

The influence of the complexity of the produce surface structure on inactivation efficacy of ACP was observed when treatments were evaluated for the reduction of background microflora naturally present on the produce. The causative agents of microbial spoilage in fruits and vegetables can be bacteria (*Erwinia* spp., *Enterobacter* spp., *Propionibacterium chlohexanicum*, *Pseudomonas* spp., and

lactic acid bacteria) as well as moulds and yeasts (*Penicillium* spp., *Aspergillus* spp., *Alternaria* spp., and *Saccharomyces* spp., *Cryptococcus* spp., *Rhodotorula* spp.) (Raybaudi-Massilia *et al.* 2009). In recent study conducted by Jensen *et al.* (2013), 34 different species from 23 different genera for bacteria and 22 different species from 9 different genera for yeasts were identified in strawberry samples. Despite this potential diversity of indigenous microflora, an ACP treatment time of 120 s significantly reduced the numbers on smooth surface of tomatoes in our study. However, again ACP was not very effective for the reduction of background microflora on more complex surface of strawberries, although tomato and strawberries tend to share similar bacterial communities (Leff and Fierer 2013). Indeed, the cell characteristics are important factors for inactivation efficacy, however there was no difference in inactivation rates between yeasts/moulds and mesophilic bacteria recorded in this work where produce surface characteristics played a crucial role significantly reducing decontamination efficacy of system against background microflora of produce.

Current information available for characterisation of ACP suggests that plasma is a source of heat, UV radiation, charged particles and reactive oxygen and nitrogen based species (ROS and RNS, respectively) with a main role given to the ROS as prime plasma disinfectants (Laroussi and Leipold 2004; Laroussi 2009). In this study, it was demonstrated that increasing the treatment time resulted in increased antimicrobial efficacy of ACP against bacteria inoculated on produce. Moreover, the inoculated samples were indirectly exposed to plasma, i.e., at some distance to the plasma discharge (~160 mm from the centre of the plasma discharge). In case

of indirect treatment the charged particles and the short-lived species would not be expected to play a role due to their potential to recombine before reaching the sample (Laroussi 2009). Therefore, ozone was expected to be one of the key factors contributing to antimicrobial efficacy of ACP treatments. It has been demonstrated earlier, that considerable reductions of bacteria by indirect ACP occurred within seconds when extended post treatment storage was applied, suggesting diffusion of the reactive species into liquids during post-treatment storage, thereby affecting microbial cells (Ziuzina *et al.* 2013). Extended 24 h post treatment storage time was also employed in the current study. It is likely that 24 h post treatment storage time facilitated ACP action on the bacterial cells by retaining generated reactive species within closed container, thus, promoting diffusion of the species inside the product tissue.

In the current work, as the treatment time increased, a significant increase in the ozone generated by plasma inside the package containing produce was noted. However, it was also observed that the produce type influenced the concentration of ozone, where lower ozone levels were recorded for strawberry samples. Strawberries surface exhibit numerous pores, likely making the surface contact area larger than the area of tomato surface. This surface area differential may contribute to the increased dissolution rate of ozone generated inside the strawberry package, with subsequent reduced antimicrobial efficacy of ACP with regard to the all bacteria tested.

Considering the lower ozone concentrations and the consequent lower reductions of the challenge bacteria and background microflora on strawberries, it is likely

that protection by more complex produce structures could be a critical parameter determining plasma treatment efficacy. Similarly, Fernandez *et al.* (2013) demonstrated that antimicrobial efficacy of plasma was influenced by produce surface features with higher bacterial reduction levels achieved on microbial filters than on more complex biotic surfaces.

As mentioned earlier, in this study, variations between initial populations of bacteria were apparent, with *Salmonella* and *L. monocytogenes* more readily attaching on the surface of either produce than *E. coli*. Regardless of the different surface features of the produce studied, SEM images confirmed the larger populations of *L. monocytogenes* adherent cells in addition to clusters of cells present. Despite the irregular nature of strawberry surface, which would probably facilitate bacterial attachment, *E. coli* populations visualised by SEM on the fruit surface were still less dense by comparison with *L. monocytogenes* images. A possible explanation for the lower levels of attached *E. coli* is the presence and interaction with naturally existing indigenous epiphytic bacteria. Depending on the types of epiphyte present the survival of pathogens can be either enhanced or inhibited (Erickson 2012). For example, Cooley *et al.* (2006) demonstrated that one epiphyte *Enterobacter asburiae* isolated from lettuce, inhibited colonisation of *E. coli*, whereas another epiphyte *Wausteria paucula* had the opposite effect, enhancing *E. coli* survival.

Other factors that may affect microbial attachment to fresh produce are the different morphology and chemistry of the produce as different fruits and vegetables offer different microniches for the attachment, penetration and

proliferation of bacteria (Keeratipibul *et al.* 2011). Motility of microorganisms facilitates pathogen entry into wounds, stomata and other existing fruit surface openings (Deering *et al.* 2012). We observed in SEM images that bacterial cells were likely adhered inside the natural crevices of produce surface or close to these regions. Naturally existing cracks and pits on the surface of produce provide bacteria opportunity to internalise. Internalisation through the naturally existing opening is widely described in literature and considered as one of the major route of pathogens entry to plant tissue (Deering *et al.* 2012). Incidences of internalisation dependent upon concentration of bacteria, their location on the plant, age, integrity and stages of plant development, as well as indigenous agonistic/antagonistic bacteria present on plant have been reported (Shi *et al.* 2009; Erickson 2012). This study indicated that the decontaminating effect of ACP is a function of produce type and the contaminating pathogen. The produce surface has an influence on pathogen attachment, with the potential for internalisation particularly associated with minimally processed fresh produce. Therefore the depth to which the plasma generated chemical species are able to diffuse through a tissue in order to affect internalised cells or those within a biofilm requires further investigation to elucidate how that diffusion capability of ACP can be effectively harnessed. Overall, the results of this study indicated that bacterial attachment and increased survivability on more complex surfaces following ACP treatments should be considered as very important factors influencing treatment design.

4.7. Conclusion

In summary, the high voltage indirect ACP treatment was highly efficient for decontamination of fresh produce inside a sealed package. Short treatment times of 10, 60 s and 120 s resulted in reductions to undetectable levels of *Salmonella*, *E. coli* and *L. monocytogenes*, respectively on cherry tomatoes. However, treatment times of up to 300 s were required to attain substantial reductions on strawberry surfaces. Similarly, yeasts/moulds and mesophiles on tomato surface were not detected after 120 to 300 s, respectively. Thus, it can be concluded that ACP treatment with 24 h post treatment storage can eliminate microorganisms on fresh produce surfaces inside a sealed package. In order to achieve optimum decontamination efficiency by ACP, factors including type of produce, their inherent surface characteristics, bacterial type, the strength and the nature of their attachment as well as the diffusion capacity of the plasma species should be considered.

Chapter 5: ACP INACTIVATION OF BACTERIAL BIOFILMS ON ABIOTIC SURFACE

Bacterial biofilms are characterized by an enhanced resistance to most environmental stresses including commonly used disinfectants and therefore represent an important source of human infections (Olmez and Temur 2010; Belessi *et al.* 2011). In previous studies, it has been demonstrated that in-package high voltage ACP treatment can effectively inactivate bacteria suspended in liquid media, i.e. in their planktonic form. In addition, this non-thermal technology was shown to effectively reduce different types of microorganisms inoculated on fresh produce with different surface morphology. These results indicate that ACP could be a potential decontamination method for more complex bacterial structures, i.e. biofilms.

The objective of this study was to investigate antimicrobial efficacy of in-package high voltage DBD ACP for elimination of challenge biofilms of one Gram-negative microorganism, *E. coli*, and two Gram-positive microorganisms, *L. monocytogenes* and *S. aureus*, grown on abiotic surface. Initially, CV staining was utilised in order to assess the ability of biofilm formation in different bacterial strains, using a range of incubation times. The effects of treatment time and mode of plasma exposure on antimicrobial activity of ACP were examined in terms of reduction of biofilms culturability and metabolic activity. The results of this work clearly demonstrated that ACP could be a potential strategy for inactivation of the established bacterial biofilms. However, the type of bacteria in conjunction with biofilm composition and induction of VBNC state might have an effect on ACP inactivation efficacy.

5.1. Bacterial biofilm quantification by crystal violet assay

Figure 21 represents optical density (OD) at 590 nm of CV stained bacterial biofilms formed after 24 h and 48 h of incubation. According to the scheme described by Stepanovic *et al.* (2000), 24 h old *E. coli* and *S. aureus* were classified as weak biofilm formers, whereas *L. monocytogenes* demonstrated moderate ability to produce biofilms. Further incubation for 48 h resulted in increase in total biomass of biofilms. It should be noted, that after 48 h of incubation, stained bacterial biofilms were clearly visible as a purple ring on the surface of the wells of the 96 well microtiter plate. Based on these results, only bacterial biofilms grown for 48 h were used for further studies on the efficacy of ACP to inactivate bacteria in the realistic but also more resistant biofilm form.

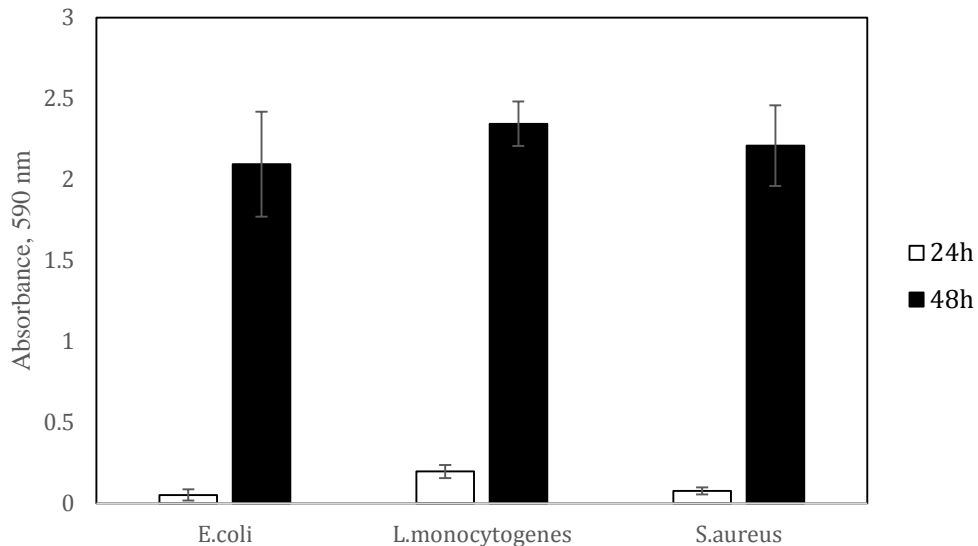

Figure 21: Bacterial biofilm formation after 24 h and 48 h of incubation evaluated by CV assay.

5.2. Effect of ACP treatment on bacterial biofilms

To investigate the efficacy of ACP to inactivate bacteria within biofilms, surviving bacterial populations in biofilm were estimated by colony count and XTT assay, to assess bacterial culturability and metabolic activity, respectively, within complex biofilm structures.

5.2.1. Colony count assay

Surviving populations of *E. coli*, *L. monocytogenes*, *S. aureus* 48 h biofilms as a function of ACP treatment time and different types of ACP exposure, i.e. direct and indirect, are presented in Fig. 22. The average initial population of *E. coli* recovered from 0 h control biofilms was $5.4 \log_{10}$ CFU/ml (Fig. 22a). All studied ACP treatment times, 60, 120 and 300 s, reduced test bacteria to undetectable levels utilising either direct or indirect type of exposure (detection limit $1.0 \log_{10}$ CFU/ml).

Significant reduction ($P \leq 0.05$) in populations of *L. monocytogenes* biofilm was observed with an average decrease from the mean value of $6.3 \log_{10}$ CFU/ml before treatment (0 h control) to an average of $2.8 \log_{10}$ CFU/ml recorded after 60 s of direct/indirect treatment (Fig. 22b). Increasing direct treatment time from 60 s to 120 s did not affect the cells of *L. monocytogenes* biofilms, while 120 s of indirect treatment was more effective, significantly reducing cell numbers from $3.0 \log_{10}$ CFU/ml, achieved after 60 s of treatment, to an average of $1.9 \log_{10}$ CFU/ml ($P \leq 0.05$). Concentrations of *L. monocytogenes* cells in biofilms exposed for 300 s in combination with direct exposure significantly decreased to an average of $1.1 \log_{10}$ CFU/ml and those exposed to indirect treatment for 300 s were outside detection

limits. Significant differences between populations that were ACP treated for either 60, 120 or 300 s and 24 h control biofilms were noted in the case of both *E. coli* and *L. monocytogenes* ($P \leq 0.05$).

The inactivation effect of ACP treatment against *S. aureus* biofilms is depicted in Fig. 22(c). Similar reduction levels were observed when surviving biofilm populations exposed to either direct or indirect types of ACP treatment were compared. Both direct and indirect treatments for 60 s significantly reduced concentration of cells by an average of 2.9 \log_{10} CFU/ml from 6.5 log of the untreated 0 h control ($P \leq 0.05$); however, no significant difference between the populations surviving 60 s of treatment and 24 h control biofilms was noted. Further reductions of *S. aureus* by increasing treatment times from 60 s to 120 s and 300 s were not statistically significant, but populations survived 120 s and 300 s of treatment significantly differed from the 24 h control ($P \leq 0.05$). No statistical difference was found when populations of 0 h and 24 h controls were compared in the case of all microorganisms studied.

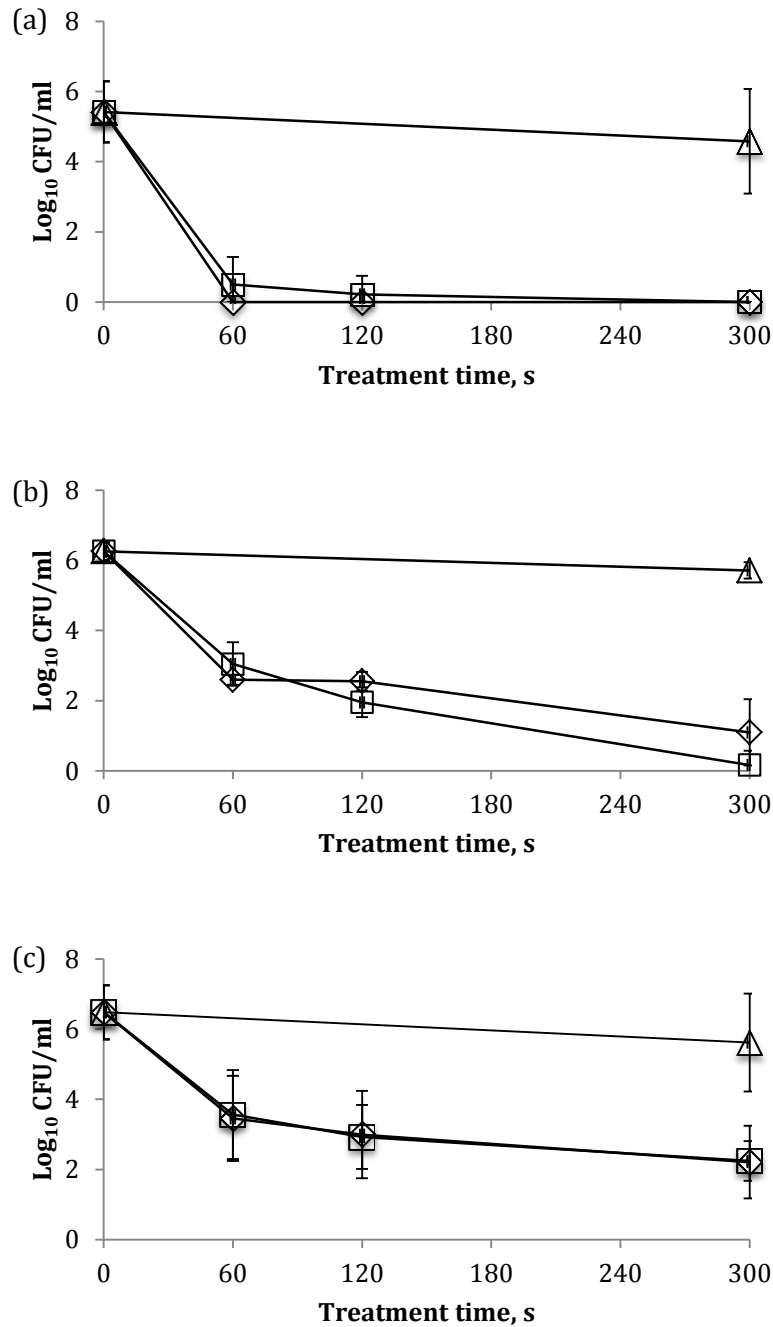

Figure 22: Surviving populations of 48 h bacterial biofilms assessed by colony count assay.

(a) *E. coli*, (b) *L. monocytogenes* and (c) *S. aureus*; untreated 24 h control (Δ), after direct (\diamond) and indirect (\square) ACP treatment. Vertical bars represent standard deviation. Limit of detection $1.0 \log_{10}$ CFU/ml.

5.2.2. XTT assay

Reduction in viability and metabolic activity of *E. coli*, *L. monocytogenes*, *S. aureus* cells embedded in 48 h biofilms after exposure to either direct or indirect ACP treatment and 24 h of post treatment storage time are presented in Fig. 23. In the case of the three microorganisms studied, there was no statistical difference found between the effects of direct and indirect types of ACP exposure. Thus, direct/indirect ACP treatment for 60 s reduced populations of *E. coli* cells by an average of 77.7 % (Fig. 23a). Further increase in treatment time from 60 s to 120 and 300 s did not significantly affect the metabolic activity of bacterial cells with maximum average reduction of 90 % achieved after an extended treatment for 300 s generated by either direct or indirect type of ACP.

Figure 23(b) represents the effects of ACP treatment on metabolic activity of *L. monocytogenes* cells in biofilms. Percentage values, arrived from the XTT absorbance, indicate the increased inactivation efficacy of ACP with increasing treatment time. Direct treatment for 60, 120 and 300 s reduced metabolic activity of *L. monocytogenes* cells to an average of 55.5, 30.6 and 8.7 %, respectively, with no statistical difference found between the groups treated with 60 and 120 s, 120 and 300 s, and 60 s and 24 h untreated control. In the case of indirect exposure all percentage reduction values obtained from the corresponding treatment times of 60, 120 and 300 s significantly differed between each other and untreated (both 0 h and 24 h) controls ($P \leq 0.05$). The percentage of metabolically active cells decreased to an average of 49.5, 20.5 and 3.8 %, after 60, 120 and 300 s of indirect treatment, respectively.

A rapid decline in cell metabolic activity due to both direct and indirect type of ACP treatment was observed in case of *S. aureus* biofilms (Fig. 23c). The percentage cells surviving 60 s of treatment constituted an average of 23.5 %, and decreased further to almost nil as the treatment time increased from 60 s to 120 and 300 s. There was no statistical difference found between percentage values obtained from 0 h and 24 h controls in the case of the three microorganisms examined.

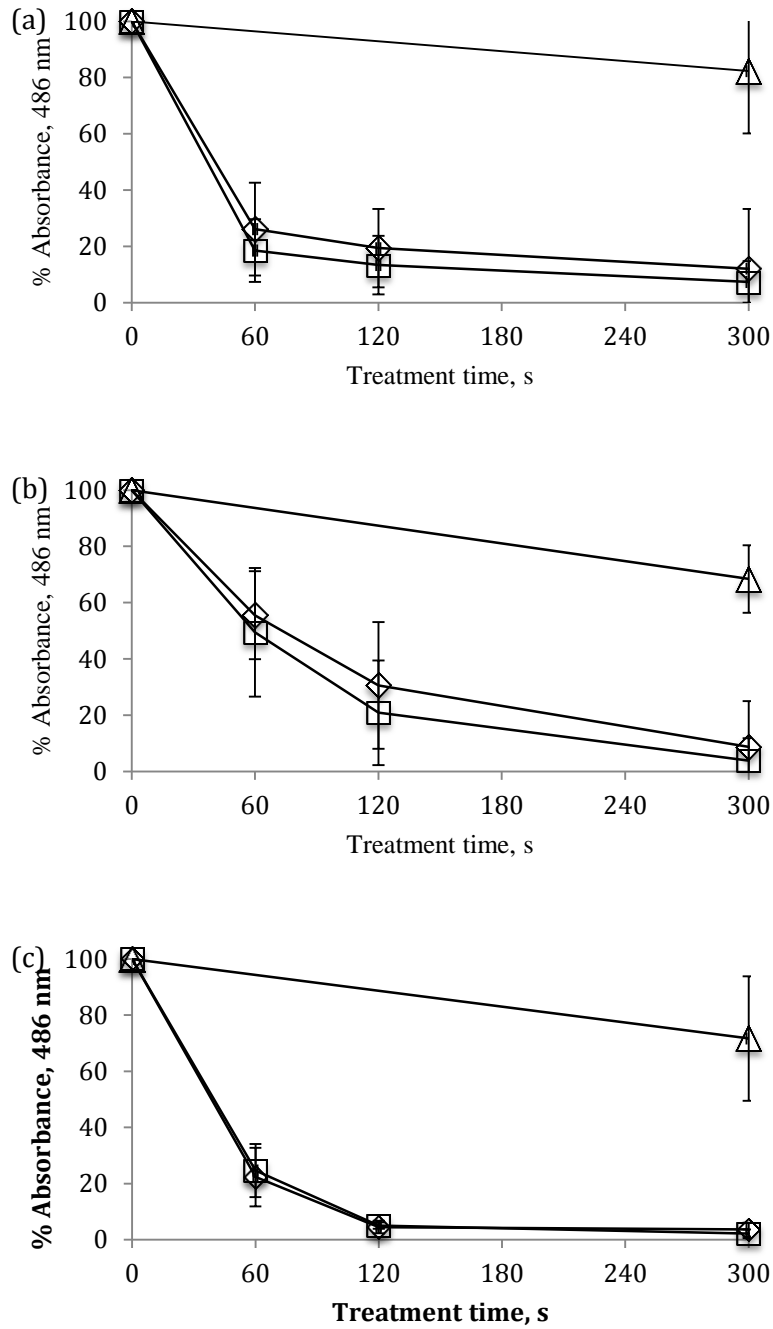

Figure 23: Percentage surviving populations of 48 h bacterial biofilms assessed by XTT assay.

(a) *E. coli*, (b) *L. monocytogenes* and (c) *S. aureus*; untreated 24 h control (Δ), after direct (\diamond) and indirect (\square) ACP treatment. Vertical bars represent standard deviation.

5.2.3. SEM analysis

SEM analysis was used to visualise the effect of ACP treatment on bacteria in the form of a complex biofilm structure. Figure 24 shows SEM images obtained for *E. coli* 48 h biofilms either untreated 0 h control or treated with ACP for 300 s using direct exposure. Images of the *E. coli* control sample confirmed the presence of healthy cells and biofilm matrix formation (Fig. 24a), whereas after ACP treatment, a large proportion of bacterial cells was disintegrated and cell debris fragments were found on the surface of PET membrane (black arrows) (Fig. 24b). However, in several areas of ACP treated membrane bacterial cells remained intact (white arrow), confirming the cell metabolic activity results obtained from the XTT assay.

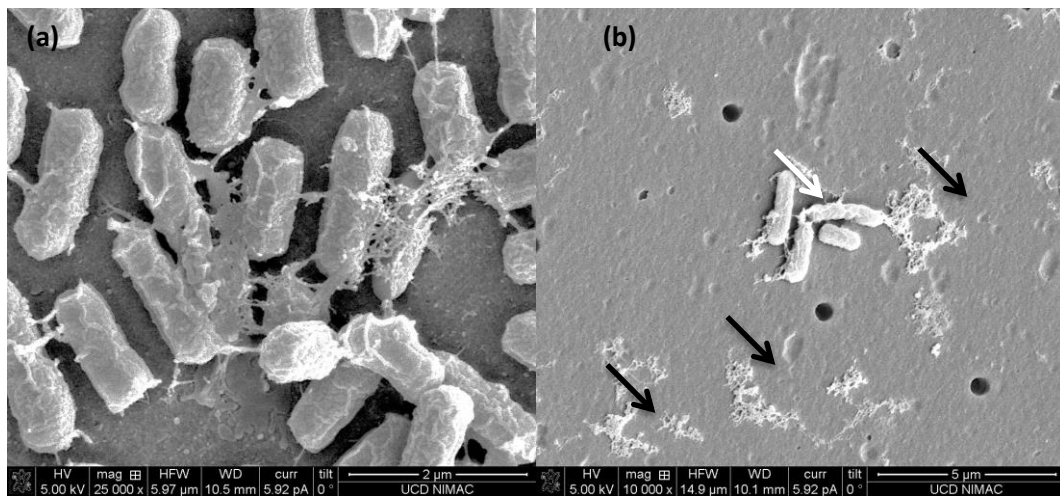

Figure 24: SEM images of *E. coli* 48 h biofilm.

(a) untreated 0 h control and (b) after 300 s of direct ACP treatment.

5.3. Discussion

Microbial biofilms tend to form on a wide variety of surfaces, including living tissues, indwelling medical devices, industrial or potable water systems, food and food-contact surfaces, thereby establishing reservoir for continuous contamination (Donlan 2002; Shi and Zhu 2009). In response to the biofilm resistance as well as the emergence of microorganisms with an increased tolerance to broad-spectrum antibiotics and the diversity of microorganisms implicated in human illnesses, extensive research into efficient inactivation and removal of bacterial biofilms has been carried out. Among the various methods, ACP technology demonstrated remarkable effectiveness against a range of microorganisms, including antibiotic-resistant biofilm forming strains (Mai-Prochnow *et al.* 2014). However, the antimicrobial effect of this technology was reduced against biofilms when compared to their planktonic counterparts (Joshi *et al.* 2010; Maisch *et al.* 2012). Our previous studies demonstrated that high voltage DBD ACP in conjunction with treatment of contaminated objects inside sealed package and following post treatment storage of 24 h was very effective for inactivation of bacteria, reducing the numbers within seconds. Therefore, in the present study the potential of ACP to inactivate bacterial pathogens was investigated against a range of microbial pathogens commonly implicated in foodborne and healthcare associated human infections, *E. coli*, *L. monocytogenes*, *S. aureus*, in the form of monoculture biofilms.

The widely used CV assay is known as a good indicator of the total biomass. Therefore, in this study, CV was utilised for evaluation of the selected bacterial

strains for biofilm formation. It was demonstrated that all strains formed substantial amounts of biofilm after 48 h of incubation when compared to the 24 h of incubation. Since bacteria in older biofilms are more resistant to antimicrobial treatments (Shen *et al.* 2011; Traba and Liang 2011), only biofilms grown for 48 h were utilised for further studies to present a realistic challenge to the ACP treatment.

Either direct or indirect atmospheric air ACP treatment in conjunction with 24 h of post treatment storage was highly effective against challenge 48 h biofilms with no significant difference in inactivation efficacy observed between the two different types of ACP exposure. The 24 h of post treatment storage time used in conjunction with in-package ACP treatment allowed the retention of plasma generated reactive species inside the pack over time, facilitating bactericidal action of both types of exposure. Possibly, the reductions after indirect treatment would only be feasible to achieve with species retention, as the action of treatment is mainly based on the reaction of long lived and recombined species rather than on the combined action of charged particles positive and negative ions, electrons, free radicals, excited and non-excited molecules and atoms associated with direct treatment. The efficiency of ACP treatment was found to be bacterial type dependant. Biofilms by their nature are complex biomaterials, composition of which will vary between the type and strain of bacteria (Vu *et al.* 2009). According to colony counts, short treatment for 60 s reduced populations of Gram-negative *E. coli* biofilms to undetectable levels, whereas this treatment time resulted in lower reductions levels of Gram-positive *L. monocytogenes* and *S. aureus* biofilms.

Although inactivation rates of *L. monocytogenes* biofilms were slower in comparison with rapid reduction of *E. coli*, an extended direct treatment for 300 s reduced *L. monocytogenes* cells by $> 5.0 \log_{10}$ CFU/ml and cells recovered after indirect ACP were outside detection limits. Large proportions of *S. aureus* biofilm populations were inactivated after 60 s of treatment ($\sim 3.0 \log_{10}$ CFU/ml) with maximum reduction of $\sim 4.0 \log_{10}$ CFU/ml achieved after extended treatment time of 300 s, indicating a stronger resistance of this strain. It has been reported that Gram-positive bacteria are more resistant to ACP treatments than Gram-negative bacteria (Montie *et al.* 2000; Lee *et al.* 2006; Ermolaeva *et al.* 2011; Ulbin-Figlewicz *et al.* 2014). The thicker membrane of the Gram-positive bacteria can present a barrier to the diffusion of ACP reactive species through the bacterial cell wall, thus impacting ACP antimicrobial efficacy. The different modes of ACP action against Gram-positive bacteria and Gram negative have been also reported. For example, Frohling *et al.* (2012a) observed that cell membrane of *L. innocua* remained intact during ACP treatment and ACP generated species reacted rather with cellular components, whereas both the cell membrane and cellular components of *E. coli* were affected. In contrast, Klämpfl *et al.* (2012) found no difference in inactivation efficacy of ACP between Gram-negative and Gram-positive bacteria, suggesting that there is no selectivity in the action of ACP generated species based on the bacterial cell wall structure. In the current work, in addition to the difference between Gram-positive and Gram-negative bacteria, different ACP inactivation efficacy was noted for the reductions of biofilms of the two Gram-positive bacteria, *L. monocytogenes* and *S. aureus*, where *S. aureus*

exhibited higher resistance to treatment than *L. monocytogenes*. These observations could be related to the shape of bacterial cells, where spherical-shaped *S. aureus* (cocci) was more resistant to ACP than rod-shaped *L. monocytogenes*. Similarly, Bodur and Cagri-Mehmetoglu (2012) demonstrated increased resistance of *S. aureus* biofilms to scallop shells powder treatment comparing to *L. monocytogenes* biofilms. For instance, the inactivation efficacy of ultrasound can be influenced by the shape of bacterial cells with more resistant spherical cells than rod-shaped cells (São José *et al.* 2014). However, the effects of ACP treatment on different bacteria possessing different cell shape remain unclear and warrant further investigations, particularly in situations where multi-species challenges exist.

Because colony count assay estimates the number of cells that, surviving the treatment, are able to grow on TSA agar, but does not account for cells that might be metabolically active, XTT assay was conducted in order to detect the retention of metabolic activity of bacterial cells exposed to ACP treatment. The XTT method involves intracellular reduction of XTT to a water-soluble formazan, the absorbance of which is proportional to the number of metabolically active bacterial cells (Peeters *et al.* 2008). This method has been successfully utilised to measure the state of bacterial cells after application of sanitizers as well as ACP treatment (Joshi *et al.* 2010; Sun *et al.* 2012; Alkawareek *et al.* 2012b). In general, relatively good correlation between results obtained from XTT and colony counts was found in the case of Gram-positive *L. monocytogenes* and *S. aureus* biofilms. However, corresponding results for Gram-negative *E. coli* indicated that although 60 s of treatment was capable of reducing bacterial counts to undetectable levels, complete

inactivation of metabolic activity could not be achieved even after extended treatment for 300 s. It is known that under one or more environmental stresses bacteria may enter VBNC state or so-called dormant state, a strategy that bacteria employ to tolerate conditions that are detrimental to growth (Brelles-Marino 2012; Ayrapetyan *et al.* 2015). The results obtained from XTT assay indicated that bacteria possibly entered VBNC state due to oxidative stress encountered from chemically reactive species generated by ACP. These results were supported by SEM analysis conducted to examine changes of *E. coli* biofilm morphology after direct ACP treatment for 300 s. The images of treated biofilms confirmed the bactericidal action of ACP showing significant changes in biofilms, with the structures altered from healthy cells interconnected by self-produced EPS matrices as found on the images of the untreated samples, to irregularly shaped cell fragments. However, although most of the cells were disintegrated, intact cells were found after exposure to ACP, suggesting that treatment could not inactivate bacteria completely as determined by colony count assay. Surviving cells present on ACP treated membrane indicate retention of cell metabolic activity, i.e. presence in their dormant, VBNC state. Microbial pathogens in such a state may not only retain virulence but be potentially dangerous as stressed cells can be of higher virulence potential than bacteria exposed to favourable growth conditions (Rowan 2004).

This study also demonstrated that, according to the XTT assay, indirect ACP exposure had a slightly stronger inactivation effect on bacterial biofilms in case of *E. coli* and *L. monocytogenes*. These results point to the complex interaction

between reactive species generated by plasma and biofilms, suggesting that the action of plasma was mainly based on the reaction between the long lived and recombined species which probably had greater ability to penetrate biofilms further inactivating the cells, rather than on charged particles or short lived species of the direct treatment (Laroussi 2009).

One of the main mechanisms of biofilm resistance is the protective barrier of the negatively charged EPS matrix (Costerton and Lewandowski 1995; Donlan 2002; Vu *et al.* 2009), which could possibly prevent the penetration and further action of strongly charged chemically reactive species of the ACP treatment. The most studied regulatory mechanism that has been found to control the production of EPS and biofilm formation is QS (Vu *et al.* 2009). QS is a phenomenon whereby bacteria can communicate with each other through the use of the signalling molecules and when the concentration of these molecules reach a threshold level, regulation of specific genes expression is triggered (Griffiths 2005). Because QS was demonstrated previously to be involved in biofilm formation, inhibiting QS by ACP may possibly play a more crucial role in inactivation of biofilms by plasma treatment. Using appropriate methodologies these questions will be further addressed in the following sections.

There are other important criteria, which could demonstrate the potential of ACP treatment for control of biofilm-associated issues. This includes the efficacy of ACP to remove bacterial biofilms, i.e. etching effect of plasma. As mentioned earlier, CV is known as a widely used technique to quantify bacterial biofilms through its ability to stain DNA, proteins and polysaccharides, and, thus, describe

the total biomass of the biofilm. Therefore, this technique may be appropriate for studying the removal of bacterial biomass from the surface onto which the biofilms are attached. Our preliminary studies based on utilisation of CV biofilm staining of 24 h old *E. coli*, demonstrated that etching effect has not occurred after plasma exposure for 120 s (data not shown). Traba and Liang (2011), utilising CV staining assay, reported that higher discharge power and extended treatment time were required to achieve plasma etching effect. Moreover, in our study, according to CV optical density, increase in total *E. coli* biomass after 120 s of ACP treatment was noted, whereas XTT assay indicated that complete inactivation of cells within 24 h biofilm had occurred. This suggests that even if bacterial damage at cellular level occurred, dead cells debris can still contribute to the total amount of biomass. Such response of bacterial biofilms was also reported by Romanova *et al.* (2007), which applied benzalkonium chloride against *L. monocytogenes* biofilms demonstrating the increase in OD of CV after the treatment.

This work demonstrated that ACP treatment in conjunction with post treatment storage time affected bacterial biofilms significantly reducing the culturability and metabolic activity of cells. This could also be associated with the pre-treatment drying step, which, leaving no moisture or available nutrients for bacteria during subsequent storage, could induce oxidative action of ACP generated reactive species. However, within health care or industrial settings, the attached microbial cells as well as developed biofilms may be exposed to nutrient rich environments, supporting further biofilm formation, dispersal, consequent cross-contamination and initiation of infection. Therefore, different real scenarios relevant to food

production or healthcare settings should be considered in the experimental design with respect to bacterial strain, substrate, media type, temperature conditions and other potential stressors for the development of bacterial biofilms in order to develop specific treatment approach and to holistically describe and compare antimicrobial effects of treatment.

5.4. Conclusion

In conclusion, this study was mainly focused on evaluation of ACP treatment efficacy against 48 h old bacterial biofilms developed on abiotic surface. In order to demonstrate the diversity of the efficacy of ACP treatment, three different bacterial strains were utilised. The results of this work clearly demonstrated that ACP could be a potential strategy for inactivation of the established 48 h bacterial biofilms. However, the type of bacteria in conjunction with biofilm composition might have an effect on ACP inactivation efficacy. Furthermore, despite ACP treatment penetration abilities and destructive action against bacterial cells within complex biofilm structures, bacterial metabolic state and cell characteristics could be important factors determining the efficacy of ACP.

Chapter 6: ACP INACTIVATION OF BACTERIAL BIOFILMS AND ASSOCIATED BACTERIA INTERNALISED IN LETTUCE

Microbial biofilms and bacteria internalised in produce tissue may reduce the effectiveness of decontamination methods. The main objective of this study was to investigate the inactivation efficacy of in-package DBD ACP against *Salmonella Typhimurium*, *Listeria monocytogenes* and *Escherichia coli* in the forms of planktonic cultures, biofilms formed on lettuce and associated bacteria internalised in lettuce tissue. The effects of different time and temperature storage conditions on bacterial internalisation and biofilm formation on lettuce and any possible effects on ACP antimicrobial efficacy were also evaluated utilising different techniques, including colony count assay, scanning electron microscopy (SEM) and confocal laser scanning electron microscopy (CLSM).

This study demonstrated that effectiveness of ACP treatment strongly depended on storage conditions, bacterial type and age of biofilm, with maximum of $5 \log_{10}$ CFU/sample achieved after extended 300 s of treatment. Scanning electron and confocal laser microscopy pointed to the incidence of bacterial internalisation and biofilm formation, which influenced the inactivation efficacy of ACP. This study demonstrated that high voltage in-package ACP has the potential to overcome the different forms of bacterial challenges associated with food produce. The existence of biofilms and internalised bacteria should be considered when developing ACP treatment parameters in order to achieve an effective control of foodborne pathogens.

6.1. Effect of ACP on planktonic bacterial populations in lettuce broth

Surviving populations of *Salmonella*, *L. monocytogenes* and *E. coli* suspended in lettuce broth 3% are depicted in Fig. 25. Average initial cell concentration in the media was 6.8, 7.2 and 6.4 log₁₀ CFU/ml for *Salmonella*, *L. monocytogenes* and *E. coli*, respectively. Within 30 s of treatment and 24 h of post treatment storage at 4°C populations of all bacteria tested were reduced to undetectable levels (limit of detection 1.0 log₁₀ CFU/sample).

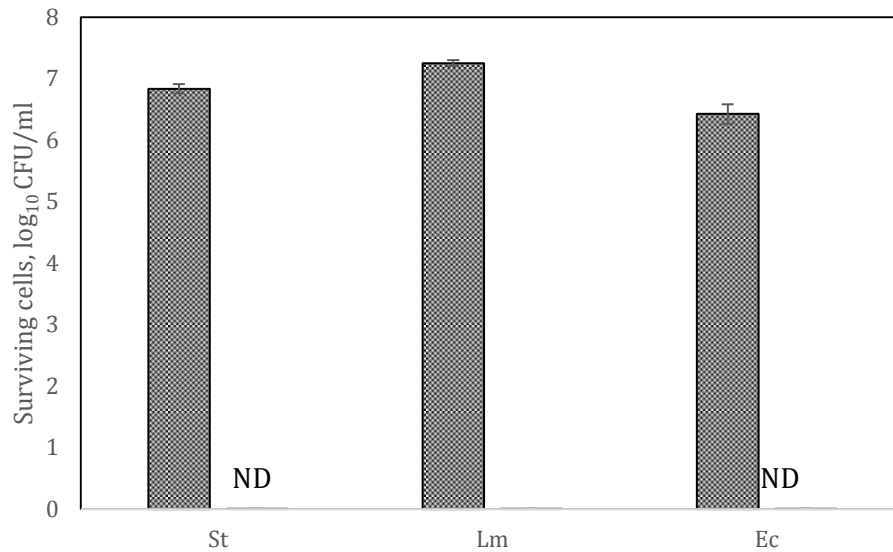

Figure 25: Effect of ACP treatment (30 s) and post treatment storage time (24 h at 4°C) on bacteria suspended in lettuce broth (3%).

Salmonella (St), *L. monocytogenes* (Lm) and *E. coli* (Ec): (▨) inoculated control and (■) ACP treated samples. ND: not detectable, limit of detection 1.0 log₁₀ CFU/ml.

6.2. Effect of ACP on bacterial populations inoculated on lettuce

The antimicrobial efficacy of ACP against bacteria inoculated on lettuce is presented on Fig. 26. Deep-inoculation of lettuce in *Salmonella*, *L. monocytogenes* and *E. coli* cell suspension for 2 h resulted in average attached populations of 6.5, 6.0 and 5.6 log₁₀ CFU/sample, respectively. ACP treatment time of 300 s reduced *Salmonella* and *L. monocytogenes* counts by 2.4 and 2.3 log₁₀ CFU/sample, respectively. Greater inactivation was observed for *E. coli*, where treatment reduced bacterial numbers by 3.3 log₁₀ CFU/sample.

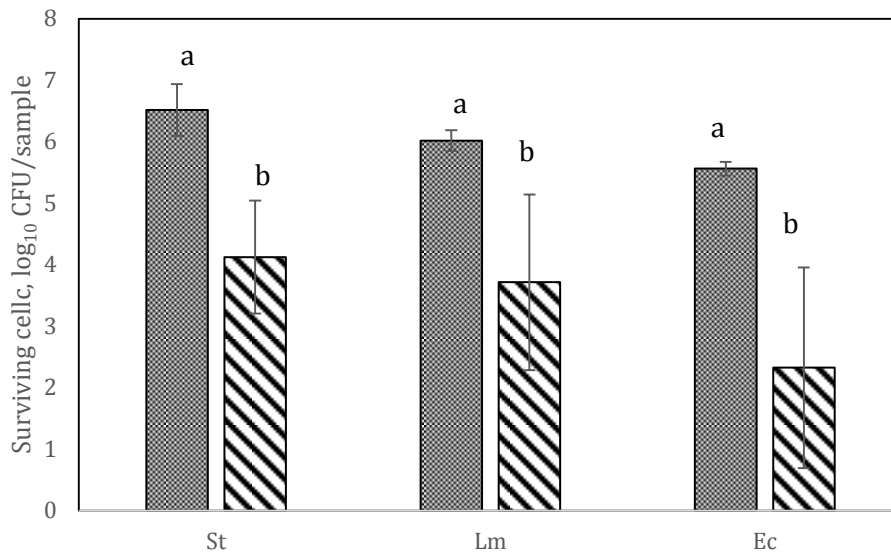

Figure 26: Effect of ACP treatment (300 s) and post treatment storage time (24 h at 4°C) on bacteria inoculated on lettuce.

Salmonella (St), *L. monocytogenes* (Lm) and *E. coli* (Ec): (■) untreated control and (▨) ACP treated samples. Columns with different letters indicate a significant difference between the bacterial levels (P<0.05).

6.3. Effect of ACP on internalised bacteria and bacterial biofilms formed on lettuce at room temperature in light/dark photoperiod

Average initial populations of *Salmonella*, *L. monocytogenes* and *E. coli* 24 h and 48 h biofilms grown at room temperature in light/dark photoperiod and corresponding reductions due to ACP treatment are presented in Fig. 27. After 300 s of treatment, the concentration of cells in 24 h biofilms of each bacteria tested were reduced significantly ($P \leq 0.05$) compared with an average of the untreated (0 h, 24 h and 48 h) controls. Thus, *Salmonella*, *L. monocytogenes* and *E. coli* decreased by 4.0, 3.5 and 3.0 \log_{10} CFU/sample from 7.8, 6.8 and 6.2 \log_{10} CFU/sample initially present on lettuce, respectively. Increased resistance to ACP treatment was observed in the case of 48 h biofilms with 1.8 log units reduction achieved for *Salmonella* and 1.6 log for *L. monocytogenes* biofilms. Similar reduction levels of 1.6 \log_{10} CFU/sample were observed for *E. coli* 48 h biofilms; however, these reductions were statistically insignificant as compared to the untreated controls.

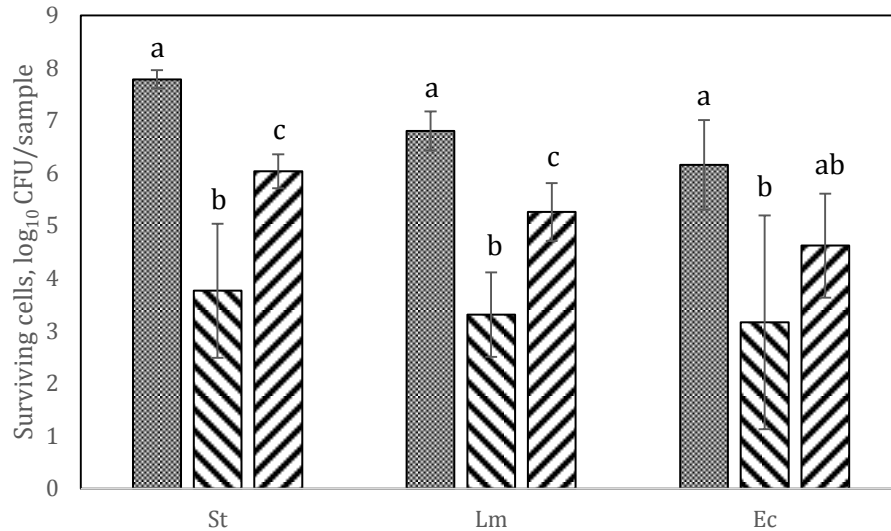

Figure 27: Effect of ACP treatment (300 s) and post treatment storage time (24 h at 4°C) on bacterial biofilms formed on lettuce at room temperature in light/dark photoperiod.

Salmonella (St), *L. monocytogenes* (Lm) and *E. coli* (Ec): (▣) untreated control, ACP treated 24 h (▤) and 48 h (▥) biofilms. Columns with different letters indicate a significant difference between the bacterial levels ($P < 0.05$).

6.4. Effect of ACP on internalised bacteria and bacterial biofilms formed on lettuce at 4°C in light/dark photoperiod

Figure 28 represents surviving populations of *Salmonella*, *L. monocytogenes* and *E. coli* for 24 h and 48 h biofilms developed at 4°C in light/dark photoperiod. ACP treatment for 300 s significantly reduced *Salmonella* 24 h and 48 h biofilms ($P < 0.05$), which decreased by 1.6 and 3.3 \log_{10} CFU/sample, respectively, from the initial 5.6 \log_{10} CFU/sample obtained as an average of the untreated 0 h, 24 h and 48 h controls. No significant reduction in the levels of *L. monocytogenes* and *E. coli* 24 h biofilms was observed after the treatment. However, populations of 48 h

L. monocytogenes and *E. coli* biofilms significantly decreased by 3.4 and 3.3 log₁₀ CFU/sample (P < 0.05) when compared to the untreated controls of 6.5 and 5.3 log₁₀ CFU/sample, respectively. Overall, similar antimicrobial effects of treatment were noted when reduction levels of 48 h biofilms of each pathogen are compared (~ 3.3 log units).

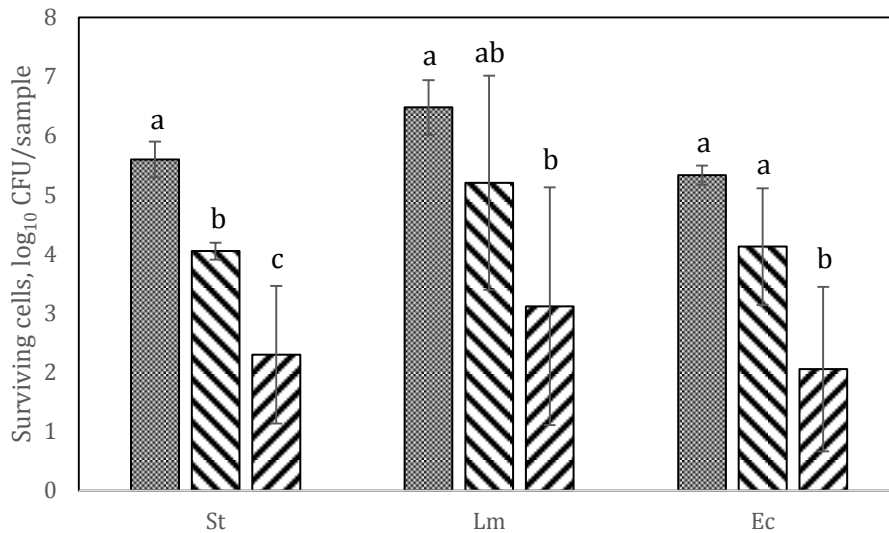

Figure 28: Effect of ACP treatment (300 s) and post treatment storage time (24 h at 4°C) on bacterial biofilms formed on lettuce at 4°C in light/dark photoperiod.

Salmonella (St), *L. monocytogenes* (Lm) and *E. coli* (Ec): (▣) untreated control, ACP treated 24 h (▤) and 48 h (▥) biofilms. Columns with different letters indicate a significant difference between the bacterial levels (P<0.05).

6.5. Effect of ACP on internalised bacteria and bacterial biofilms formed on lettuce at 4°C in dark

Relatively higher biofilm inactivation levels due to ACP treatment were observed when post-inoculation storage conditions for lettuce of 4°C in dark was utilised for biofilm development (Fig. 29). Thus, treatment for 300 s reduced populations of

Salmonella, *L. monocytogenes* and *E. coli* 24 h biofilms by 4.1, 3.8 and 3.0 log₁₀ CFU/sample from initial 6.7, 5.9 and 5.2 log₁₀ CFU/sample, respectively. Although there was no statistical difference between reductions in population of 24 and 48 h biofilms observed, the maximum biofilm inhibition was achieved for 48 h biofilms, where counts were further decreased by 5.1, 4.5 and 4.0 log₁₀ CFU/sample.

A mixed design ANOVA was conducted to assess the impact of three different storage condition groups, i.e. 'room temperature and light/dark', '4°C and light/dark' and '4°C and dark' on bacterial susceptibility towards ACP treatment across three time groups, i.e. untreated, stored for 24 h/treated and stored for 48 h/treated samples for each type of bacteria studied. For *Salmonella*, there were significant differences in cell numbers found between the time groups, $F(2,18)=54.7$; $p<0.05$ and between the storage groups, $F(2,9)=17.9$; $p<0.05$. Specifically, all three storage groups significantly differed between each other at untreated control time, while at 48 h the 'room temperature and light/dark' significantly differed from '4°C and light/dark' and '4°C and dark' groups ($p<0.05$). The tests between subject effects demonstrated substantial interaction between the time and storage groups, $F(4,18)=7.9$; $p<0.05$. Similarly, for *L. monocytogenes* significant differences in cell numbers were found between the storage groups $F(2,9)=12.8$; $p<0.05$, specifically between the groups of 'room temperature and light/dark' and '4°C and light/dark' or '4°C and dark' groups and between the 'room temperature and light/dark' and '4°C and dark' group at the time group of 24 and 48 h, respectively. The main effects comparing the three time groups was also found to be significant $F(2,18)=31.8$; $p<0.05$ and significant

interaction was again observed between time and storage groups $F(4,18)=7.7$; $p<0.05$. There was no significant interaction found between the time and storage groups in the case of *E. coli*, $F(4,18)=2.3$; $p=0.094$. However, the main effect of the three time groups across the three storage conditions as well as between the storage groups at each time point tested was found to be significant $P(2,18)=17.3$; $p<0.05$ and $P(2,9)=6.5$; $p<0.05$, respectively.

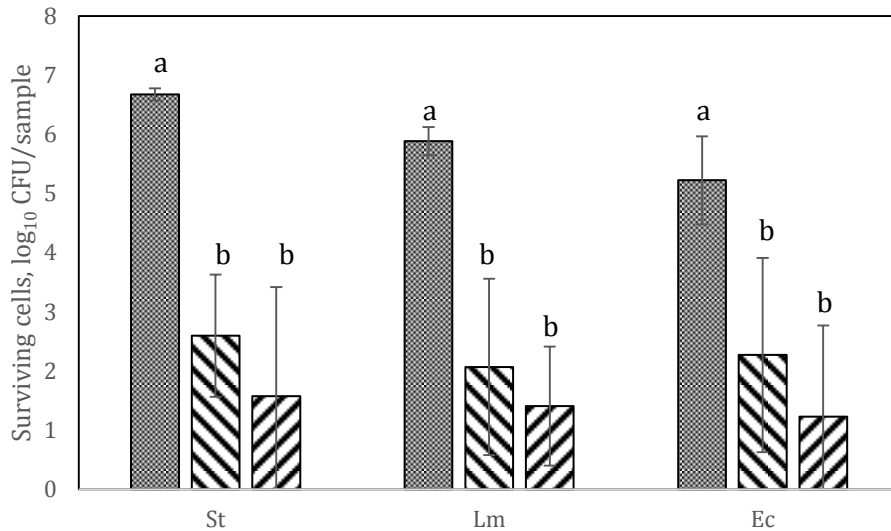

Figure 29: Effect of ACP treatment (300 s) and post treatment storage time (24 h at 4°C) on bacterial biofilms formed on lettuce at 4°C in dark.

Salmonella (St), *L. monocytogenes* (Lm) and *E. coli* (Ec): (■) untreated control, ACP treated 24 h (▨) and 48 h (▩) biofilms. Columns with different letters indicate a significant difference between the bacterial levels ($P<0.05$).

6.6. CLSM analysis

In order to examine if storage conditions, such as temperature and light, had any effects on localization of cells within the plant tissue and possible effects on ACP treatment, CLSM analysis was conducted using GFP-tagged *E. coli* inoculated on lettuce. CLSM images (Fig. 30) illustrate the distribution of fluorescent *E. coli*

cells on lettuce following 24 h incubation at different storage conditions. Figure 30(a) and 30(b) represent localization of cells on the lettuce as a result of storage at room temperature and 4°C in the light/dark photoperiod, respectively. Both conditions resulted in firm cell attachment on the surface and cell internalization in lettuce stomata. In contrast, for inoculated lettuce samples stored at 4°C in the dark (Fig. 30c), no incidence of internalisation was noted: cells were mostly attached to the lettuce surface and near stomatal areas.

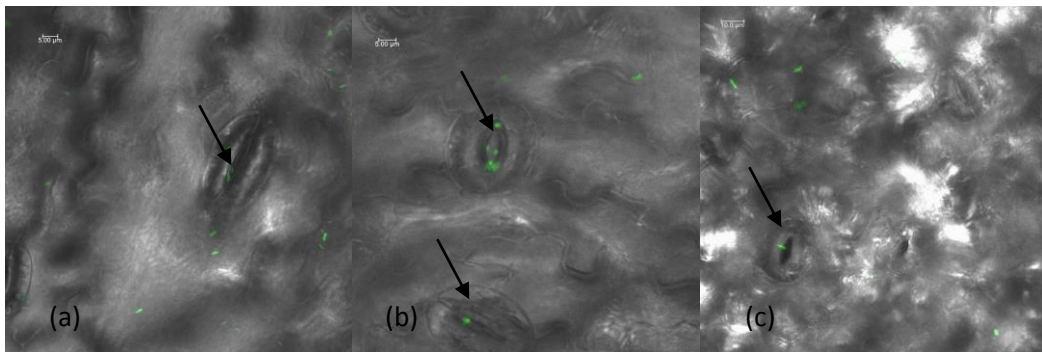

Figure 30: CLSM images of *E. coli* XL10 (GFP) 24 h biofilms formed on lettuce.

(a) room temperature in light/dark, (b) 4°C in light/dark and (c) 4°C in dark. Arrows indicate localisation of cells.

6.7. SEM analysis

SEM analysis was utilised in order to observe the effects of high voltage ACP treatment on bacterial biofilms and internalised bacteria associated with lettuce (Fig. 31). SEM micrographs (Fig. 31a) show localization of untreated *Salmonella* cells in a 48 h biofilm formed on lettuce at room temperature for the light/dark photoperiod. The untreated lettuce bacteria were found to be healthy individual

cells, in the form of small clusters, biofilms aggregates attached on the lettuce surface, near the stomata and internalised inside the stomata (black arrows). The majority of the stomata on the control samples subjected to imaging were highly colonized with bacterial cells; however, some of the stomata were colonized to a lesser degree or found to be uncolonized. Images of ACP treated samples (Fig. 31b) indicated the presence of cell debris around the stomata (red arrows). It is more likely that the action of ACP caused bacterial cell ruptures irreversibly changing the original morphological characteristics of the cells. However, among the dead cell fragments found on the surface of the lettuce, intact cells were still present inside stomata post treatment (black arrows).

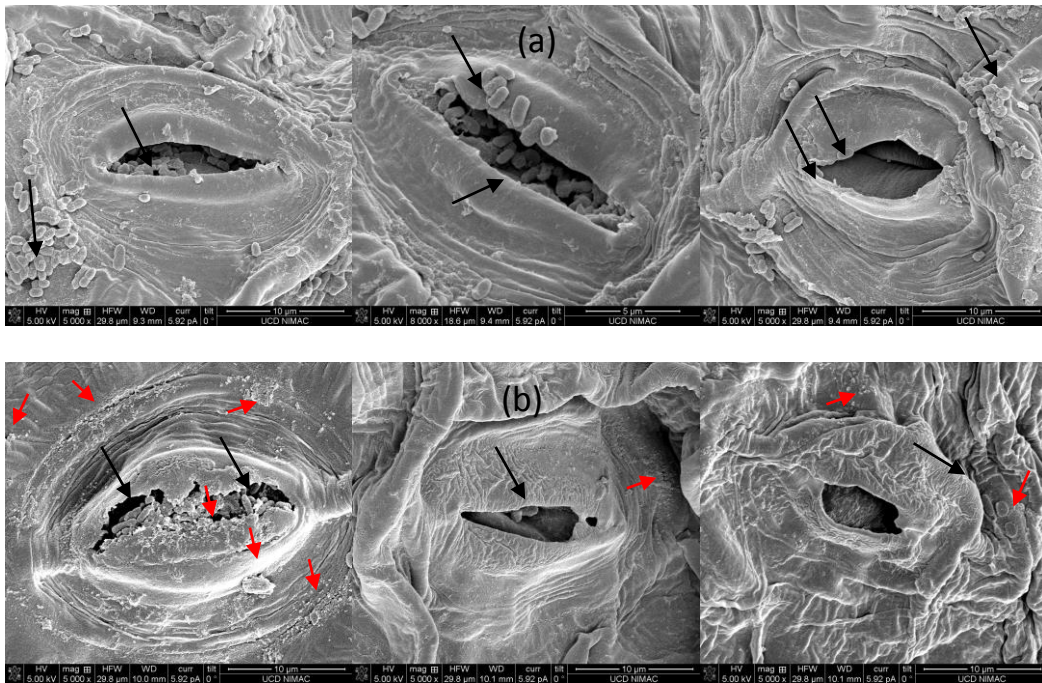

Figure 31: SEM images of *Salmonella* 48 h biofilms formed on lettuce at room temperature and light/dark photoperiod.

(a) untreated control and (b) ACP treated sample. Black arrows indicate intact bacterial cells and red arrows indicate cell debris.

6.8. ROS measurements

Concentrations of ROS generated after 30 s of indirect ACP treatment inside *L. monocytogenes* and *E. coli* cells suspended either in PBS or in LB (3%) are presented in Fig. 32. Thus, an average concentration of ROS generated inside either *L. monocytogenes* or *E. coli* cells suspended in PBS was twice as high as the ROS concentration recorded for cells suspended in LB. However, relatively lower levels of intracellular ROS were observed for Gram-negative *E. coli* suspended in both PBS and LB when compared to the Gram-positive *L. monocytogenes*.

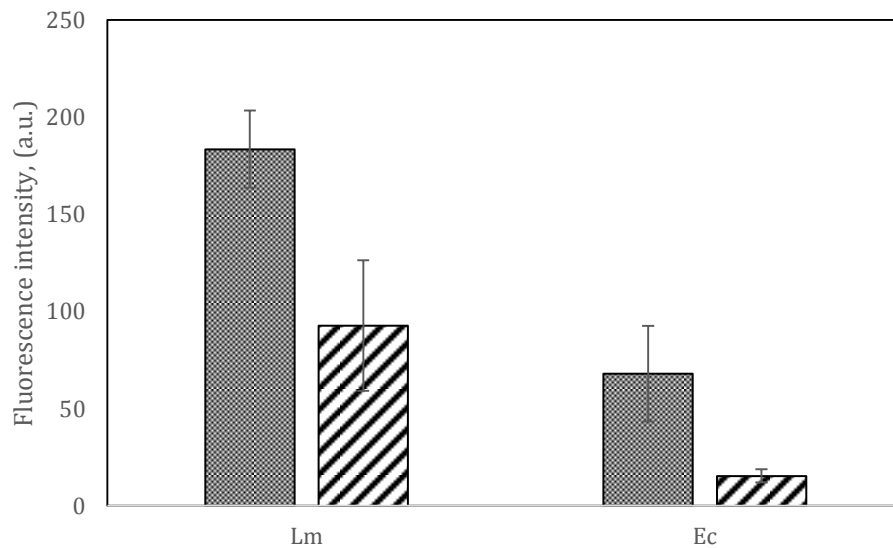

Figure 32: Concentration of ROS generated after 30 s of indirect ACP treatment inside bacterial cells.

Listeria (Lm) and *E. coli* (Ec) cells suspended in PBS (▒) and lettuce broth (▤).

6.9. Ozone measurements

Indirect ACP treatment time of 300 s resulted in an average concentration of ozone generated inside the sealed package containing inoculated lettuce samples of 4420 ± 240 ppm. Average ozone concentration recorded after 30 s of treatment of inoculated LB in 96 well plate reached 2220 ± 130 ppm.

6.10. Discussion

Recent health associated outbreaks, which have been linked to the consumption of fresh produce, have led to extensive research for more efficient decontamination techniques since current sanitation procedures show limited efficacy against bacterial pathogens attached to plant surface, internalized or in the form of biofilms (Olmez and Temur 2010; Olaimat and Holley 2012; Warning and Data 2013). To date, among the various physical and chemical food decontamination techniques evaluated, ACP demonstrated high efficiency for the reduction of bacterial contaminants from the surface of fresh produce (Fernandez *et al.* 2013; Baier *et al.* 2014; Misra *et al.* 2014; Ziuzina *et al.* 2014; Lacombe *et al.* 2015).

In this study, antimicrobial efficacy of the in-package high voltage indirect ACP treatment was examined against a range of microorganisms commonly implicated in foodborne associated human infections, namely *Salmonella*, *L. monocytogenes* and *E. coli* monocultures in their planktonic form, in the form of biofilms and associated bacteria internalised in produce. Generally, indirect high voltage ACP treatment in conjunction with 24 h of post treatment storage time was very effective against planktonic populations of the three bacteria tested. High

concentrations of bacterial cells (~7.0 log units) were reduced to undetectable levels within 30 s of treatment. These findings are consistent with previous reports, which demonstrated >5 log reduction of planktonic bacterial populations achieved within less than 60 s of plasma treatment (Joshi *et al.* 2011; Kvam *et al.* 2012; Ziuzina *et al.* 2013; Han *et al.* 2014; Jahid *et al.* 2015). However, in the current work, when challenge microorganisms were inoculated on produce, bacterial resistance to treatment considerably increased and an extended treatment time (300 s) was necessary in order to achieve significant reductions of the bacterial populations. Bacterial pathogens can rapidly and irreversibly attach on different plant commodities and persist for long periods of time; within 30 s of exposure, 30% of *Salmonella* inoculum was firmly attached to green papers slices (Solomon and Sharma 2009). Recently, Warning and Datta (2013) described that plant cuts, lenticels, trichomes, locations around the veins and stomata are the preferential places for bacterial cell attachment. Jahid *et al.* (2014a) visualised bacteria associated with the stomatal wall, as well as inside the stomata. Furthermore, Gu *et al.* (2013b) reported that following leaf colonization bacteria could enter tomato leaves through hydathodes (plant water pores), resulting in the internal translocation of the bacteria inside plants. Therefore, in the current work, it can be assumed that during 2 h of produce dip-inoculation in either *Salmonella*, *L. monocytogenes* or *E. coli* cells suspension, bacteria were strongly attached and possibly penetrated inside natural openings and indentations of lettuce leaves, which in turn considerably reduced the antimicrobial efficacy of the treatment. Similar effects was observed by Jahid *et al.* (2014a), where 15 s of ACP treatment

inactivated planktonic populations of *Aeromonas hydrophila* by > 5 log, whereas an extended 5 min of treatment was necessary to significantly reduce bacterial biofilm populations associated with lettuce. In the other study, ultraviolet C (UV-C) irradiation fluency of 35 mJ/cm² was required to achieve a 5.0 log CFU/mL reduction in planktonic populations, while 360 mJ/cm² was required to reduce bacteria cell number by ~2.0 log₁₀ CFU/cm² on lettuce (Jahid *et al.* 2014b).

In order to preserve the quality and to help assure microbiological safety, fresh produce are processed and stored at low temperatures, below 5°C (Heard 2002; Olaimat and Holley, 2012). However, real temperatures during produce distribution from field to the retail store may vary largely (Koseki and Isobe 2005) and even a slight increase in temperature (from 4 to 10°C) can adversely affect quality characteristics of the produce (Bett-Garber *et al.* 2011). Moreover, fluctuations in the temperature, humidity and light intensity throughout distribution may also influence bacterial state and localization of bacteria on the produce (Golberg *et al.* 2011). It has been reported that higher temperatures and higher light intensity may induce bacterial attachment, biofilm formation and internalisation of bacterial cells in plants (Kroupitski *et al.* 2009; Takeuchi *et al.* 2001). Therefore, because consistent storage of fresh produce at the recommended temperatures of ~5°C is difficult to maintain throughout distribution (Koseki and Isobe 2005), in this work, the effects of different storage temperatures (4°C and room temperature) in combination with different light regimes and storage times on bacterial proliferation, biofilm formation and susceptibility to ACP treatment were evaluated. The results of this study demonstrated that high voltage ACP treatment

for 300 s was capable of reducing bacterial populations in 24 h biofilms grown at room temperature in the light/dark photoperiod by up to 4.0 log units. Although there was no significant difference between bacterial populations of 24 h and 48 h untreated controls, 48 h biofilms were more resistant to treatment by comparison with 24 h biofilms. Increased resistance of older biofilms could be due to the higher proportions of extracellular polymeric substances (EPS), produced by bacteria with longer storage durations (Shen *et al.* 2011; Traba and Liang 2011). Similarly, Belessi *et al.* (2011) demonstrated that, despite a low incubation temperature of 4°C, resistance of *Listeria* biofilms to chemical treatments increased with increasing incubation time. In contrast, in the current study, different inactivation patterns were observed for both 24 h and 48 h biofilms grown at 4°C and similar light conditions, where 24 h biofilms of all three bacteria studied were more tolerant to ACP treatment than 48 h biofilms, when results are compared with reductions achieved for biofilms grown at room temperature. The reason for these unexpected results is unclear. Nonetheless, one possible explanation could be that microorganisms encountered stress during leaf inoculation caused by the temperature change from room temperature to 4°C, used for biofilm formation. It is known that when exposed to a mild stress, bacteria may adapt by developing resistance to greater amounts of that stress as well as cross-protection to other stresses (Beales 2004). In food production environments microorganisms undergo a variety of stresses including extreme temperatures, which can have a significant effect on bacterial survival during food processing thus impacting the efficacy of decontamination treatments (Delaquis and Bach

2012). For example, Al-Nabulsi *et al.* (2015) demonstrated an increased resistance of *L. monocytogenes* to antibiotic treatment when cells were exposed to temperature decreased to 10°C. In this study, the stress bacteria experienced from the first 24 h storage cycle in the cold environment could lead to the increased resistance to ACP treatment. Cells embedded in the 48 h biofilms could possibly become adapted to the low temperature and resume expression of non-cold inducible proteins (Barria *et al.* 2013), which could explain higher reduction levels of bacterial populations in 48 h biofilms achieved after treatment. However, further investigation of the bacterial adaptation to change in the environmental conditions and the corresponding bacterial response to ACP treatment may provide important information and help in future optimisation of treatment critical control parameters in order to achieve the maximal efficacy of ACP for decontamination of fresh produce.

In addition to the low temperature regime, light is considered as one of the most important factors responsible for produce quality maintenance throughout distribution and it has been reported that light exposure stimulates plant stomata opening (Martinez-Sanchez *et al.* 2011). In the current work, regardless of the low incubation temperature (4°C) and bacterial type, higher inactivation levels were achieved for both 24 h and 48 h biofilms when developed on lettuce under dark conditions. Martinez-Sanchez *et al.* (2011), who examined surface of Romaine lettuce by using SEM, found that approximately 75% of lettuce stomata were closed due to storage in darkness, whereas a similar percentage of stomata remained opened when leaves were exposed to light. Moreover, Kroupitski *et al.*

(2009) linked the increase in light intensity with higher internalisation rates of bacterial cells inside the lettuce leaf tissue. In this study, storage of inoculated lettuce in a dark environment probably induced stomata closure and where ACP generated reactive species probably acted directly on bacterial cells residing on the lettuce surface. This observation was supported by CLSM, which demonstrated an apparent difference in the localisation of bacterial cells when lettuce was exposed to different light regimes rather than different temperature regimes. In the dark, bacterial cells were located mostly on the surface of lettuce or near stomatal cavities, whereas light/dark conditions in combination with either refrigerated or room temperature storage resulted in penetration of cells within the lettuce stomata. Takeuchi *et al.* (2001) also reported higher internalisation levels of *E. coli* when lettuce was stored at 4°C as compared to 10, 22, or 37°C. In contrast, Gomez-Lopez *et al.* (2013) demonstrated that temperature differential and illumination conditions did not affect bacterial internalization into the plant. Furthermore, in this work, in contrast to the room temperature and light/dark storage condition, a combination of 4°C and darkness resulted in bacterial inactivation patterns similar to those obtained for 4°C and a light/dark photoperiod, with lower reductions achieved for 24 h biofilms than for 48 h biofilms, which confirms the effect of the temperature shift on bacterial survivability followed by treatment.

Air plasmas are excellent sources of ROS and RNS (Stoffels *et al.*, 2008). Among the ROS, ozone, atomic oxygen, singlet oxygen, superoxide, peroxide, and hydroxyl radicals, are considered to contribute to the bacterial inactivation process (Joshi *et al.*, 2011). In this work, high concentrations of ozone were recorded.

Ozone is one of the long-lived reactive species, relevant to the effects of treatment that utilises post treatment storage and is expected to play an important role in antimicrobial efficacy of ACP. The DCFH-DA assay demonstrated generation of ROS inside *L. monocytogenes* and *E.coli* cells following treatment. However, concentrations of ROS were higher inside bacterial cells suspended in simpler media, such as PBS, by comparison with the concentrations of ROS recorded for cells treated in LB. The components of LB, such as proteins and vitamins, likely scavenged many of the plasma generated reactive species thus posing a protective effect against antimicrobial action of reactive species generated during the treatment. Furthermore, despite the thicker cell membrane, concentrations of ROS were higher inside cells of Gram- positive microorganism than inside cells of the Gram-negative. Han et al. (2014), comparing ACP antimicrobial efficacy between Gram-positive and Gram-negative bacteria, demonstrated that *L. monocytogenes* was more sensitive to ACP treatment than the two *E. coli* strains studied, attributed to a higher level of ROS penetrated inside Gram- positive than inside Gram-negative microorganism. However, the exact mechanisms of plasma mediated bacterial inactivation are not yet fully elucidated. One of the proposed mechanisms is the diffusion of ROS through the bacteria cell wall, causing local damage to the cytoplasmic membrane, protein and DNA strands, as well as physical effects causing microbial etching and erosion (Gallagher et al., 2007; Moreau et al., 2008). Our previous findings showed that the penetration ability of ACP generated species into bacterial suspensions was facilitated by 24 h of post-treatment storage (Ziuzina et al., 2013). As discussed by Shintani et al. (2010), the penetration depth

of oxygen plasma generated species was predicted to be <1,000 nm as estimated from the surface of spores. Furthermore, Pei et al. (2012) demonstrated that reactive plasma species produced a strong bactericidal effect penetrating through the layer of a 25.5 µm-thick *Enterococcus faecalis* biofilm. In this study, in order to investigate if ACP mediated reactive species could penetrate the internal layers of produce, SEM analysis of untreated and ACP treated *Salmonella* 48 h biofilms developed on lettuce at room temperature and light/dark photoperiod was conducted. It was evident that the selected storage conditions supported bacterial attachment, formation of biofilm aggregates and internalization within plant stomata, and that ACP treatment in conjunction with 24 h of post treatment storage had detrimental effects on unprotected bacteria, eliminating most of the cells from the surface of lettuce. However, inside stomata, where high concentrations of cells were noted and strong biofilm formation is anticipated, bacterial cells remained intact, suggesting that ACP generated reactive species could not penetrate colonized stomata through the complex biofilm matrices. This could explain the inability of the treatment to totally eliminate bacterial biofilms as demonstrated by the colony count assay. Similarly, Jahid et al. (2015) reported increased resistance of bacterial biofilms to plasma treatments due to internalization and extensive colonization in stomatal wells. It is also important to note that the majority, but not all lettuce stomata were found to be colonized before treatment, whereas higher proportions of stomata without colonization were observed on treated samples. However, the presence of some uncolonized stomata on untreated controls makes it difficult to holistically conclude about ACP decontamination efficacy against

bacteria on the internal areas of plants. Although SEM analysis was conducted using bacterial biofilms developed under storage conditions chosen to enhance biofilm growth (room temperature), these results highlight the importance of informed effective microbiological control, as microorganisms protected by biofilms and/or the complex structures of different produce commodities may present major risks of cross-contamination of the environment in food production sites. Furthermore, internalization of bacteria in the internal natural cavities was promoted by the presence of light thereby significantly impacting ACP efficacy. Therefore, preventive measures such as maintenance of appropriate temperature regimes and minimised light exposure throughout the distribution chain remain extremely important factors for the assurance of microbiological safety of fresh produce in conjunction with novel approaches such as high voltage ACP.

6.11. Conclusion

In summary, in-package high voltage indirect ACP treatment was very effective against planktonic populations of *Salmonella*, *L. monocytogenes* and *E. coli*, reducing high concentrations of bacterial cells ($\sim 7.0 \log_{10}$ CFU/ml) in lettuce broth within 30 s of treatment. However, extended treatment times of up to 300 s were required to attain substantial reductions for bacteria attached to lettuce surfaces (2.4, 2.3 and 3.3 \log_{10} CFU/sample for *Salmonella*, *L. monocytogenes* and *E. coli*, respectively). Furthermore, it has been shown that the storage conditions, such as temperature, light and time had interactive effects on bacterial proliferation and susceptibility to the ACP treatment. After 48 h, bacterial biofilms developed on lettuce at room temperature in a light/dark photoperiod, exhibited higher resistance

to ACP than 24 h biofilms. In contrast, biofilms developed at 4°C in combination with either light storage condition during 48 h were more susceptible to the treatment than 24 h old biofilms. Overall, these results suggest that temperature and light conditions during produce distribution may promote bacterial internalisation and possible bacterial stress responses thereby significantly impacting the effectiveness of ACP and indeed other decontamination treatments. However, further research is needed, which will focus on the effects of pre-treatment storage conditions in order to understand bacterial behaviour, adaptation to stress, development of cross protection and the corresponding response to ACP treatment in order to further optimise plasma treatment parameters for the consistent inactivation of pathogens on or in produce where enhanced produce quality characteristics are also attained.

Chapter 7: ACP INACTIVATION OF *P. AERUGINOSA* BIOFILMS AND INHIBITION OF QUORUM SENSING-REGULATED VIRULENCE FACTORS

Pseudomonas aeruginosa is one of the most abundant biofilm forming microorganisms in the natural environment and is a common opportunistic nosocomial pathogen, causing a wide variety of acute and persistent infections. One of the regulatory mechanisms that bacteria use to respond to external stresses is termed quorum sensing (QS). In recent years, QS became a highly attractive target in the search for alternative antimicrobial agents. ACP showed high antimicrobial potential against a wide range of biofilm forming microbial pathogens.

The main objectives of this work was to investigate the inactivation effects of ACP against antibiotic-resistant *P. aeruginosa* in the form of established 48 h monoculture biofilms using a range of viability and metabolic activity assays, and against QS-controlled virulence factors production such as pyocyanin, elastase (Las B) and developing 24 h biofilms.

This study demonstrated the potential of a novel in-package high voltage ACP decontamination approach for inactivation of *P. aeruginosa* established 48 h biofilms. Significant reductions of *P. aeruginosa* QS-regulated virulence factors and as a result reduced cytotoxicity of *P. aeruginosa* supernatants on CHO-K1 cells were achieved, suggesting that ACP technology could be a potential QS inhibitor and may play an important role in attenuation of virulence of pathogenic bacteria.

7.1. Biofilm assays

Surviving bacterial populations in the established *P. aeruginosa* biofilm were estimated by colony count and XTT assays for determination of cell viability and metabolic activity, respectively. The ability of the contained ACP reactive species to penetrate through the biofilms complex structures was observed using LIVE/DEAD bacterial viability kit followed by CSLM. SEM was conducted in order to observe morphological changes of biofilms caused by ACP treatment.

7.1.1. CV assay

According to the scheme described by Stepanovic *et al.* (2000) 24 h and 48 h old *P. aeruginosa* demonstrated strong ability to produce biofilms (Fig. 33a). It should be noted, that after 48 h of incubation, *P. aeruginosa* biofilms were clearly visible on the surface of the wells of the 96 well microtiter plate (Fig. 33b). Based on these results, only bacterial biofilms grown for 48 h were used in further studies aimed at investigating the efficacy of ACP to inactivate bacteria in the realistic but also more resistant biofilm form.

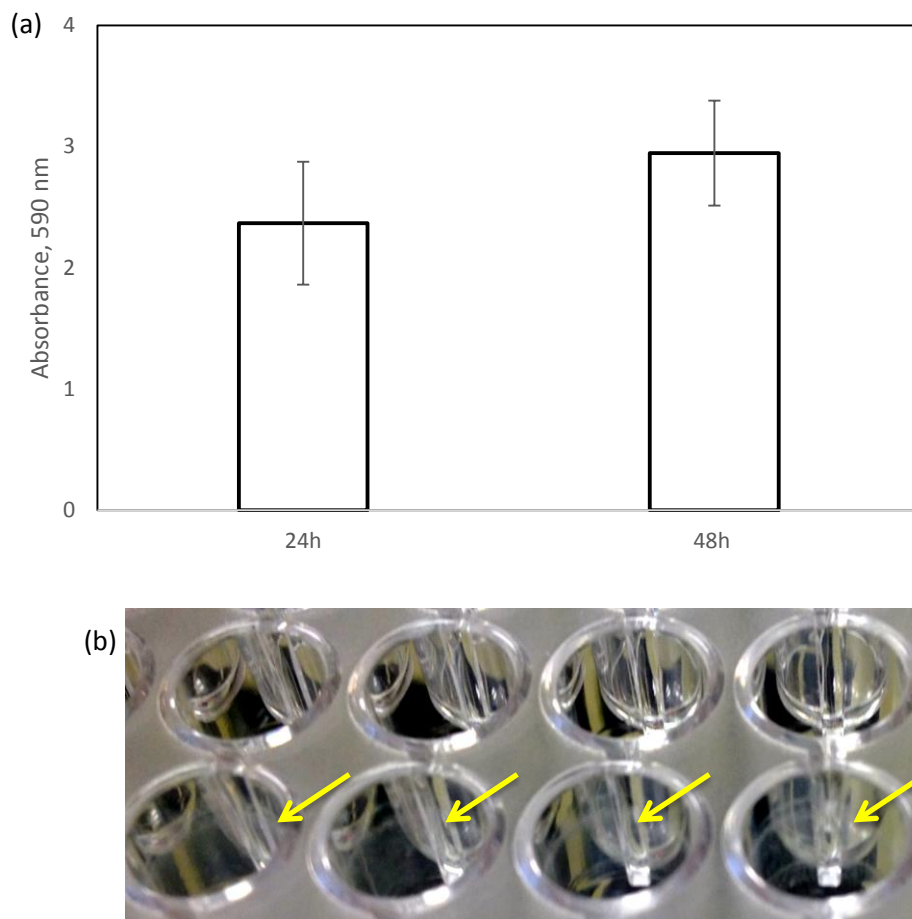

Figure 33: *P. aeruginosa* biofilm formation.

evaluated by CV assay after 24 h and 48 h of incubation at 37°C (a); photograph of *P. aeruginosa* biofilm formed in the wells of 96 well microtiter plate (b): top row - uninoculated control wells, bottom row – 48 h biofilm (yellow arrows).

7.1.2. Colony count assay

The influence of ACP treatment time and mode of exposure on viability of *P. aeruginosa* biofilms based on colony count assay is presented in Fig. 34. Generally, both direct and indirect modes of plasma exposure effectively reduced bacterial populations in biofilms after short treatment times. Prior to ACP treatment, an average population of bacterial biofilm attached on the surface of the wells was 6.6 log₁₀ CFU/ml. ACP treatment for 60 s reduced bacterial cells by an

average of 5.4 log₁₀ CFU/ml, increasing treatment time to 120 and 300 s reduced the numbers of viable cells within the biofilms to levels below detection limits (1.0 log₁₀ CFU/ml).

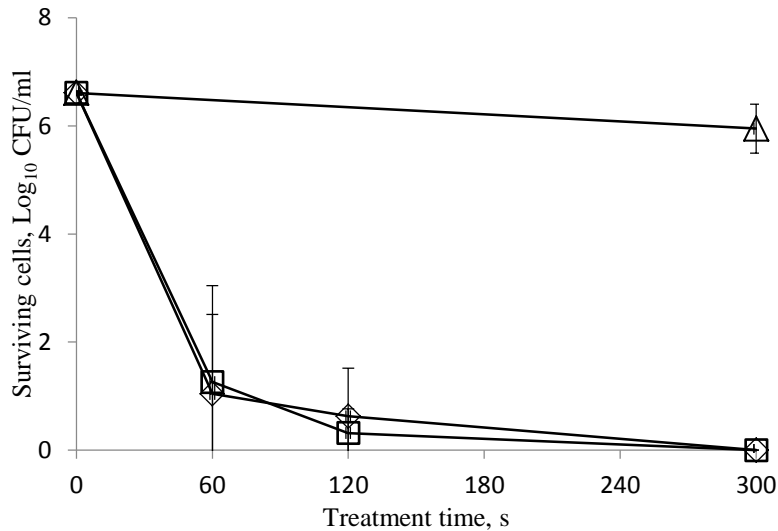

Figure 34: Surviving populations of *P. aeruginosa* 48 h biofilms assessed by colony count assay.

untreated control biofilms (Δ) after direct (◇) and indirect (□) ACP treatment. Vertical bars represent standard deviation. Limit of detection 1.0 log₁₀ CFU/sample.

7.1.3. XTT assay

Percentage survivors of *P. aeruginosa* biofilm after ACP exposure based on XTT assay are presented in Fig. 35. XTT absorbance values demonstrated that 60 s of direct and indirect treatment reduced metabolic activity of cells by 37% and 49%, respectively. Increasing treatment time from 60 to 120 s reduced cells' metabolic activity by 63% and 70% when exposed to direct and indirect treatment, respectively. However, no further reductions were observed by applying extended treatment time of 300 s, with a maximum average reduction of 70% recorded. It

should be noted that post treatment storage time of 24 h had a minor effect on biofilm activity for this microorganism based on both colony count and XTT assays.

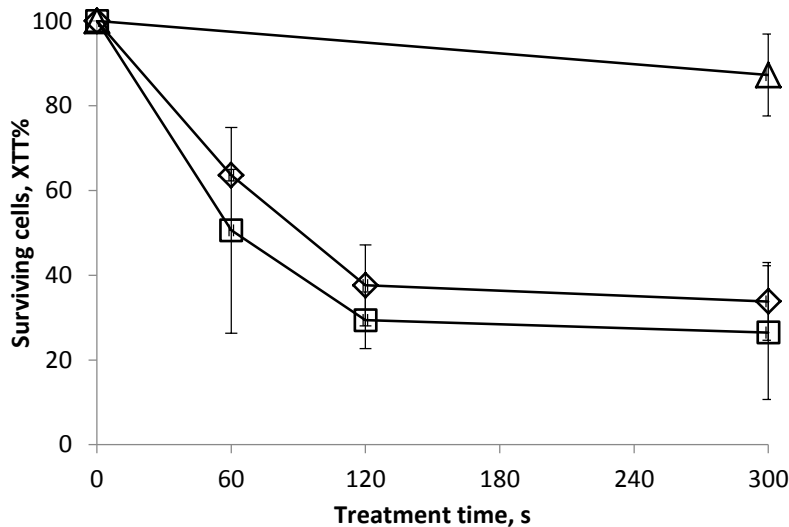

Figure 35: Percentage surviving populations of *P. aeruginosa* 48 h biofilms assessed by XTT assay.

untreated control biofilms (Δ) after direct (\diamond) and indirect (\square) ACP treatment. Vertical bars represent standard deviation. Limit of detection $1.0 \log_{10}$ CFU/sample.

7.1.4. CLSM analysis

In order to evaluate the effect of ACP on viability of bacterial cells embedded in biofilm structures, CLSM analysis of untreated control and *P. aeruginosa* biofilms treated directly/indirectly for 300 s was conducted. This analysis utilises the mixture of SYTO9 (green fluorescent) and PI (red fluorescent) nucleic acid dyes. SYTO9 labels bacterial cells with both intact and damaged membrane, whereas PI penetrates only cells with damaged membrane. Therefore, this analysis allows

determination of bacterial viability and cell membrane integrity on the basis of different colours, where green and red represent live and dead cells, respectively. The results of the CLSM analysis are presented in Fig. 36. As can be seen from Fig. 36(a) the untreated control sample exhibited completely green fluorescence, i.e. only live cells were present. Maximum biofilm thickness of 23 μm was recorded. Confocal images of biofilms treated with either direct or indirect ACP (Fig. 36b and c, respectively) displayed only red fluorescence, with no viable cells remaining after treatment. Moreover, images of ACP treated samples also indicated a substantial reduction of biofilm thickness when compared with control biofilms. The thickness of biofilms was reduced to 8 and 6 μm after direct and indirect ACP treatment, respectively.

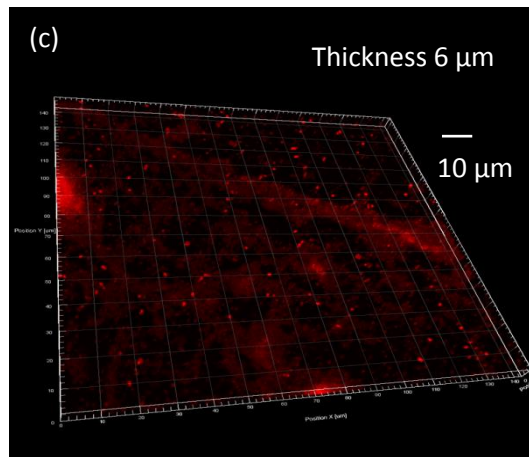
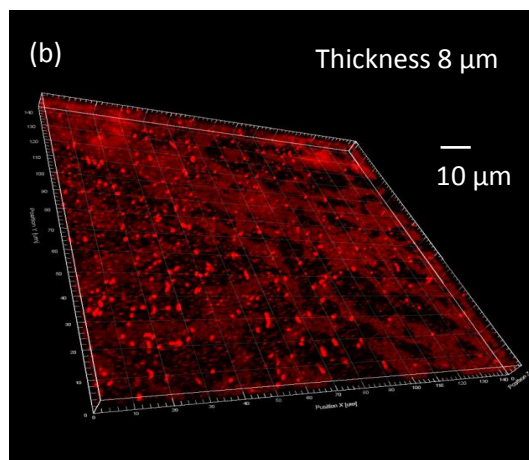
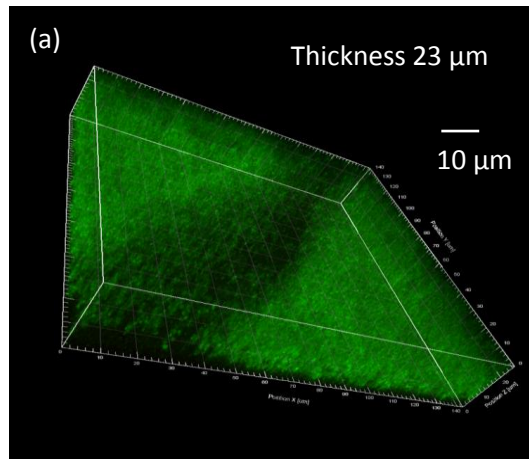

Figure 36: CLSM images of *P. aeruginosa* 48 h biofilms stained with LIVE/DEAD bacterial viability kit.

(a) untreated control, (b) 300 s of direct ACP treatment, (c) 300 s of indirect ACP treatment. Cells stained green are alive and cells stained red are dead.

7.1.5. SEM analysis

In order to examine the effects of ACP on *P. aeruginosa* biofilm distribution and morphology, SEM analysis of untreated control and samples treated directly/indirectly for 300 s was conducted. Fig. 37(a) represents untreated controls, where clustered rod-shaped bacterial cells are interconnected with each other by the complex biofilm matrix components. Significant damage of bacterial cells and EPS was observed after both direct and indirect ACP treatments. Complete disintegration of cells and biofilm matrix was noted after direct ACP treatment, where biofilms were converted into the 'sponge-like' irregularly shaped debris when compared with untreated controls (Fig. 37b). Although indirect ACP had similar destructive effects on biofilm structures, small fractions of EPS components were still detected after the treatment (Fig. 37c).

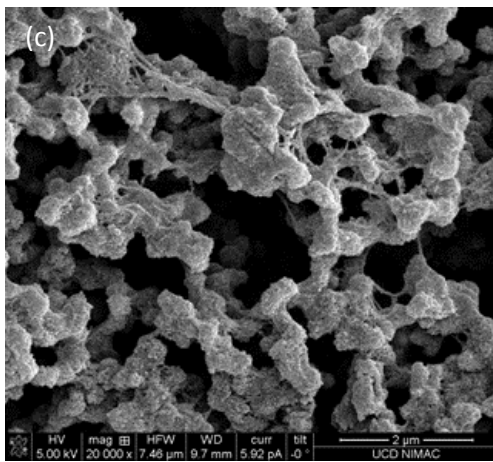
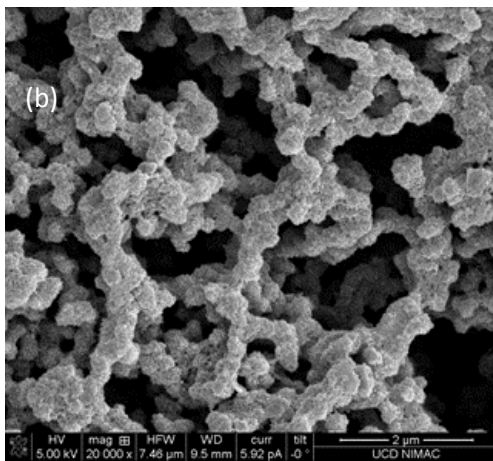
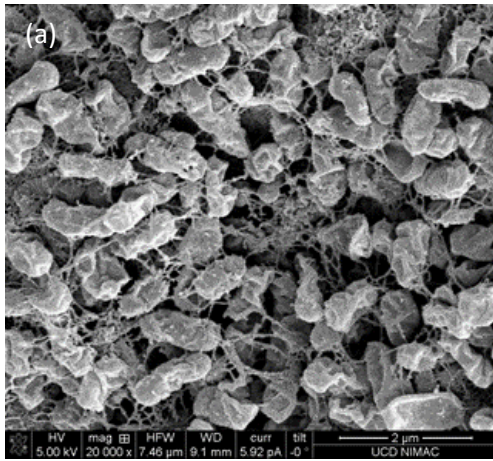

Figure 37: SEM images of *P. aeruginosa* 48 h biofilms.

(a) untreated control; (b) 300 s of direct ACP treatment; (c) 300 s of indirect ACP treatment.

7.2. Effect of ACP on quorum sensing-regulated virulence factors

The effect of ACP treatment on *P. aeruginosa* QS-controlled virulence factors was investigated utilising bacterial cell suspension and the levels of pyocyanin, elastase (Las B), biofilm formation and planktonic cell populations were studied as a function of ACP treatment time and different types of ACP exposure (Fig. 38). In a parallel study *P. aeruginosa* cell free supernatant was used to examine any possible effect of cells present during the treatment in the TSB media on the levels of pyocyanin. In general, direct and indirect type of ACP treatment similarly resulted in reduction of both pyocyanin and elastase. Determined by measuring absorbance at 520 nm, levels of pyocyanin retained after ACP treatment and 24 h of post treatment storage are shown on Figure 38(a). Short treatment for 60 s generated by direct and indirect type of ACP significantly reduced concentrations of pyocyanin by 70.7 and 88.5 %, respectively ($P \leq 0.05$), as compared to 0 h control. The levels of pyocyanin in the cell free culture supernatant were reduced by an average of 60.8 % and 68.0 % after 60 s of direct and indirect treatment (Fig. 38b), respectively, whereas an extended 300 s of treatment resulted in almost complete inactivation of pyocyanin in either cell suspension or bacterial cells free supernatant (Fig. 38a,b).

In contrast, slower inhibition rates of elastolytic activity were recorded (Fig. 38c). According to the absorbance values measured at 495 nm, only an extended direct treatment for 300 s resulted in significant reduction of elastolytic activity of elastase in comparison with the 0 h control ($P \leq 0.05$). However, elastase levels after 300 s of either direct or indirect treatments significantly differed from the

levels obtained from the corresponding 24 h untreated controls and the difference was always significant when values of 0 h and 24 h controls were compared ($P \leq 0.05$).

In order to ensure that the reduction of *P. aeruginosa* virulence factors was not due to bactericidal action of ACP, the numbers of planktonic cells in TSB were estimated performing colony count assay. From Fig. 38(d) it can be seen that there were no significant changes in bacterial cell population density noted after any of the treatment times applied.

The ACP treatments also did not influence the ability of *P. aeruginosa* to form biofilms, as there was no reduction in cell populations of the 24 h biofilms initiated from ACP treated cell suspensions (Fig. 38e).

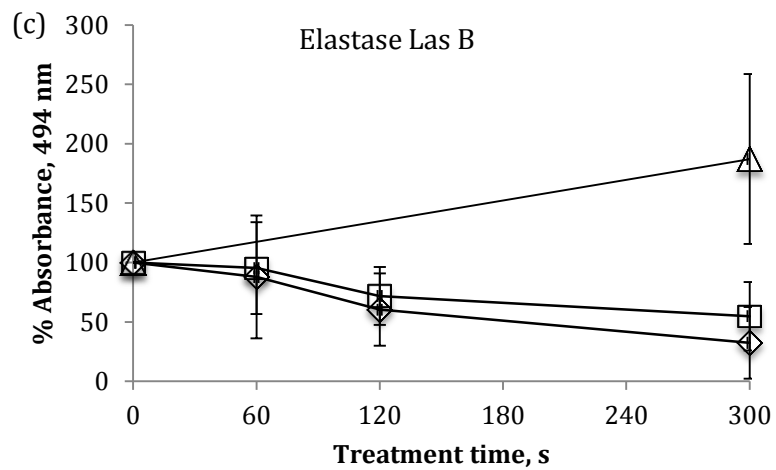
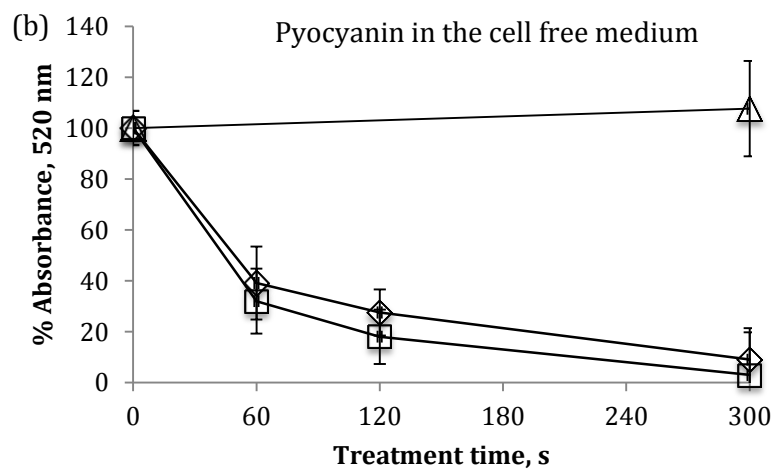
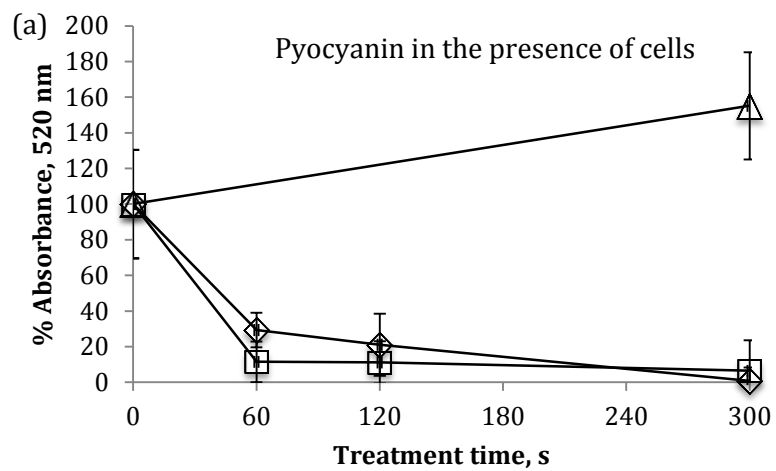

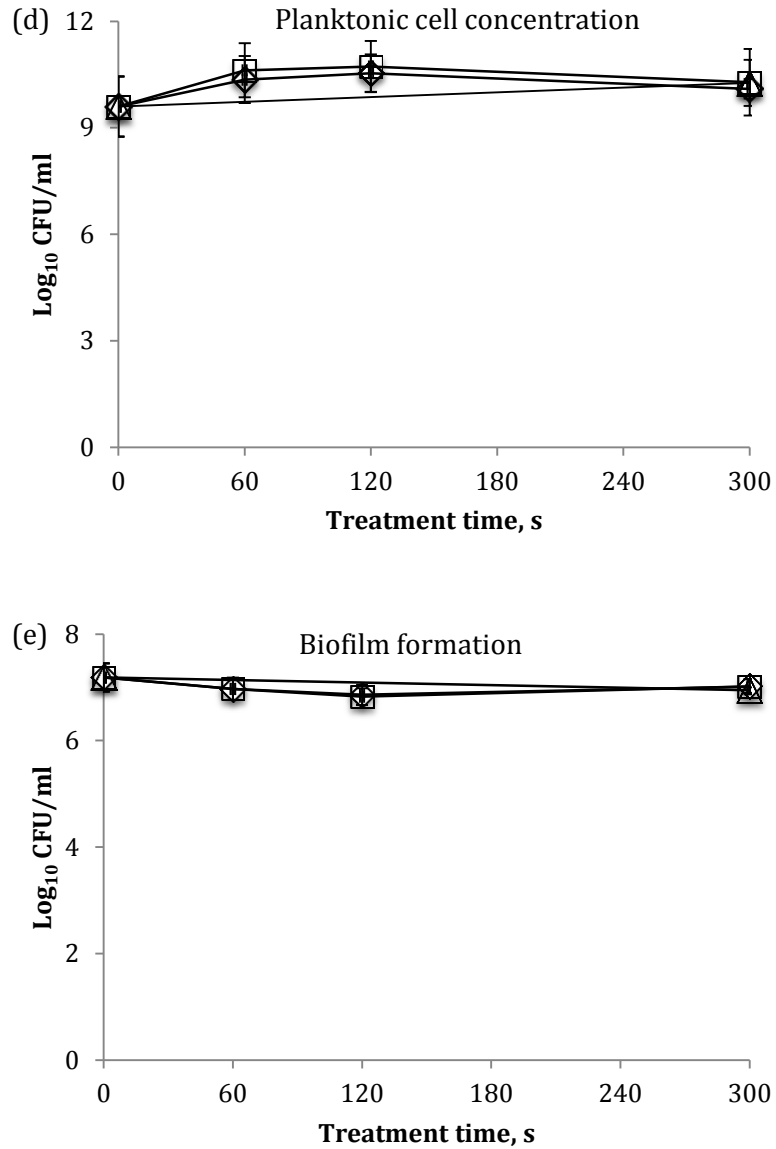

Figure 38: ACP inhibition effects on *P. aeruginosa* QS-regulated virulence factors.

(a) pyocyanin in the presence of cells, (b) pyocyanin in the cell free medium, (c) elastase Las B, (d) planktonic cell concentration and (e) biofilm formation. Untreated 24 h controls (Δ), after direct (◇) and indirect (□) ACP treatment. Vertical bars represent standard deviation.

7.3. Effect of ACP on cytotoxicity of *P. aeruginosa*

The effects of *P. aeruginosa* treated with either direct or indirect ACP for 60, 120 and 300 s and stored for 24 h or untreated and stored for 0 h and 24 h (0 h and 24 h control) on growth/adherence of CHO-K1 cells are presented on Fig. 39. Uninoculated TSB subjected to the same treatment were used as controls and untreated TSB was set as 100% cell growth. Significant reduction by an average of 92.6 % in cell growth resulted from the exposure of CHO-K1 to untreated *P. aeruginosa* 24 h control as compared to the untreated TSB ($P \leq 0.05$). Regardless of the type of treatment, exposure of CHO-K1 to *P. aeruginosa* treated with ACP for 60, 120 and 300 s supernatant resulted in significant increase in the growth of cells by an average of 62.4, 72.7 and 77.7%, respectively, when absorbance values are compared to the *P. aeruginosa* 24 h untreated controls ($P \leq 0.05$). While there was no significant difference recorded between the growth of CHO-K1 cells as a result of different treatment times applied against *P. aeruginosa* cell suspensions, a treatment time dependent decrease in cell adherence was observed when CHO-K1 were exposed to uninoculated and ACP treated TSB medium, where increase in treatment time generated by either direct or indirect type of ACP from 60 s to 120 and 300 s resulted in reduction of cell growth by an average of 55.9, 80.8 and 95.4%, respectively. Absorbance values of cultures exposed to uninoculated TSB treated with ACP for 120 and 300 s were significantly lower than the values obtained from cells exposed to ACP treated *P. aeruginosa* supernatants ($P \leq 0.05$).

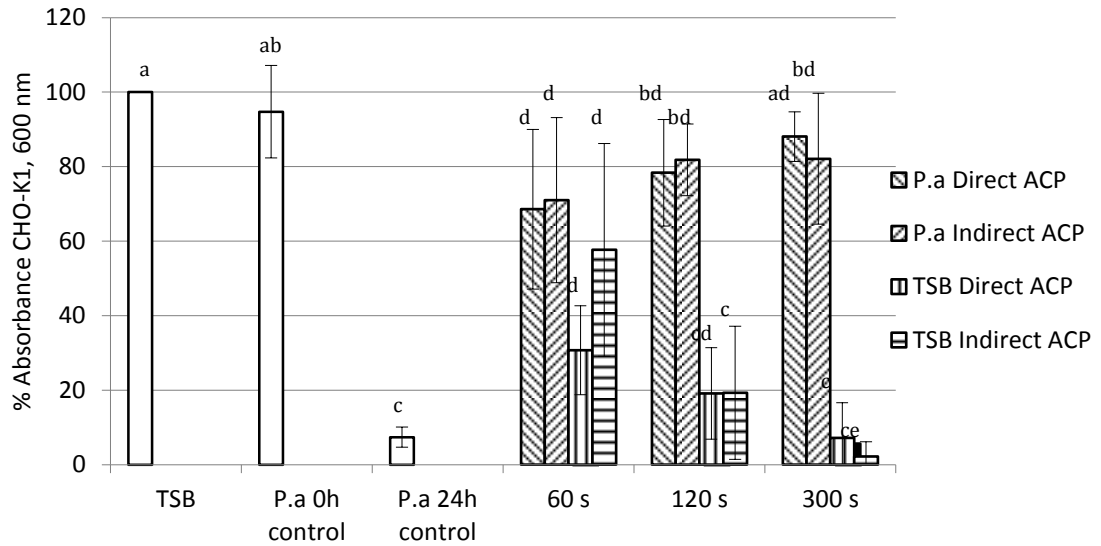

Figure 39: The effect of either untreated (0 h, 24 h controls) or ACP treated *P. aeruginosa* (P.a) and ACP treated TSB medium on growth/adherence of CHO-K1 cells.

Vertical bars represent standard deviation. Different letters indicate a significant difference in % absorbance levels.

7.4. Discussion

In recent years, ACP has been widely investigated as an alternative sterilisation technology for potential applications in food industry and medicine. This technology has been demonstrated to have great bactericidal effects against a wide range of microorganisms with high potential to avoid any thermal damage to both living and non-living biomedical structures (Cheruthazhekatt *et al.* 2010). Our previous studies demonstrated that high voltage DBD ACP in conjunction with treatment of contaminated objects inside sealed packages and following post treatment storage was very effective for inactivation of bacteria in their planktonic form, reducing the numbers within seconds (Ziuzina *et al.* 2013), however, increased resistance of bacteria in the form biofilms was recorded (Ziuzina *et al.*

2014). Bacterial biofilms, as a predominant mode of microbial growth (Costerton and Lewandowski 1995), represent major challenges in industrial and health care settings due to their increased mechanical stability and antimicrobial resistance (Gurung *et al.* 2013). Therefore, in the present study the potential of ACP to inactivate bacterial pathogens was investigated against challenge *P. aeruginosa* biofilms, as one of the major causes of healthcare associated infections.

P. aeruginosa is one of the most abundant microorganisms in the natural environment and is a common opportunistic nosocomial pathogen, which causes a wide variety of acute and persistent infections in immunocompromised patients that may be acquired through the consumption of contaminated foods, as well as via hospital environment, medical equipment or devices (Bryers 2008; Srey *et al.* 2014a). According to Neonatal Infection Surveillance Network, between 2005 and 2011, in the UK, *Pseudomonas* spp. were responsible for 93% of neonatal infection outbreaks with 18% of associated deaths (Kadambari *et al.* 2014). *P. aeruginosa* is considered as a model microorganism for biofilm research due to its excellent ability to form biofilms (Wei and Ma 2013). Since bacteria in older biofilms are more resistant to antimicrobial treatments (Traba *et al.* 2011; Shen *et al.* 2011), only biofilms grown for 48 h were utilised for further studies to present a realistic challenge to the ACP treatment. The effect of ACP treatment on *P. aeruginosa* biofilms was investigated utilising widely accepted colony count and XTT assays. According to the results obtained from both assays, no significant difference between the effects of direct and indirect mode of exposure on bacterial biofilms was found. According to colony counts, rapid inactivation of cells in biofilms was

achieved after relatively short treatments (60 s), resulting in reduction of bacterial levels by 5.4 log₁₀ CFU/ml. Although with lower inactivation rates, bacterial populations were outside detection limits after exposure to 120 s and 300 s of treatment. Similarly, Alkawareek *et al.* (2012a) reported biphasic reductions of *P. aeruginosa* biofilms due to ACP treatment, where initial 60 s of plasma treatment resulted in rapid decline in bacterial levels, causing slower reduction between 60 s and 240 s of treatment. In general, our data suggest that 80kV air in-package DBD ACP treatment exhibits considerably high inactivation potential against the most abundant and resistant bacterial form. It is worth noting, that based on our preliminary data, treatment for only 30 s was required to completely eliminate *P. aeruginosa* (~ 7.0 log₁₀ CFU/ml reduction) in their planktonic form (data not shown). In general, according to previous reports, focusing on inactivation efficacy of ACP against biofilms, complete inactivation of *P. aeruginosa* biofilms could be achieved after longer treatment times, from 5 – 10 min (Alkawareek *et al.* 2012b; Zelaya *et al.* 2010). Utilisation of different ACP systems and use of different approaches for biofilm formation is probably the main reason for variations in the published reports, which reduces the possibility to adequately conclude on the overall plasma treatment effectiveness against bacterial biofilms. Comprehensive system, process and target comparative studies are still required.

In order to examine the effects of ACP on the metabolic state of *P. aeruginosa* biofilms, the XTT assay was conducted. According to the results obtained from the XTT assay, even after extended treatment time of 300 s, an average of 30% of cells in biofilms were still metabolically active. It was also observed by Alkawareek *et*

al. (2012b), that ACP inactivated 85% of *P. aeruginosa* cells according to colony counts, while the XTT absorbance value corresponded to 36%. Borges *et al.* (2013) observed similar bacterial response to stress, when *P. aeruginosa* biofilm was subjected to naturally derived compounds with 30% of cell metabolic activity remaining after the treatment. In general, these results indicate that bacteria, failing to grow on the bacteriological media but are still alive according to metabolic activity assay, are possibly in VBNC state. This has been demonstrated for many microorganisms when facing environmental stress, including *P. aeruginosa* (Moritz *et al.* 2010; Oliver 2010). Bacteria in VBNC state can regain culturability and retain virulence even when they are in the non-culturable state and therefore may contribute to further contamination (Oliver 2005).

CLSM in conjunction with nucleic acid dyes SYTO9 and PI was used to evaluate the effects of ACP treatment on viability and cell membrane integrity. Microscopic observations demonstrated that the bacterial cell membrane was completely ruptured following treatment, which points to potential destruction abilities of the high voltage system used. Although high sterilisation potential is among the main characteristics and advantages of every antimicrobial technique, physical removal of bacterial biofilms is another important criteria, which has gained increased attention, specifically in plasma - biofilm research. Confocal microscopy analysis also demonstrated that ACP treatment was able to not only successfully inactivate cells through penetration inside complex bacterial aggregates but also substantially remove the biofilm from the associated surface, which was identified by measuring the thickness.

The results of this work also point to the complex interaction between reactive species generated by air plasma and biofilms. As commonly known, air plasma is an excellent source of electrons and positive and negative ions, free radicals, stable conversion products (e.g. ozone), excited atoms and molecules, and ultraviolet radiation photons (Stoffels *et al.* 2008). The main mechanism of action of ACP reactive species is diffusion of oxygen species through the bacteria cell wall causing local damage to the cytoplasmic membrane, protein and DNA strands, as well as physical effects by causing microbial etching and erosion (Gallagher *et al.* 2007; Moreau *et al.* 2008). In this study, in order to monitor the physical changes caused by ACP treatment SEM analysis of biofilms was conducted. The microscopic images enabled observation of the differences between control (untreated) samples, which proved biofilm complexity and the resulting challenge linked to antimicrobial resistance, and treated samples, where cells and biofilm components were significantly damaged by action of ACP.

It should be noted, that the in-package high voltage ACP treatment used a 24 h post treatment storage time. This allowed the retention of plasma reactive species inside the pack over time, thus facilitating bactericidal action of these species on biofilm samples. This approach is more likely to show increased antimicrobial effects of plasma, the mechanism of which is mainly based on the reaction of long lived and recombined species rather than on charged particles or short lived species, which are more relevant to effects noted using treatment without post treatment storage. This approach could contribute to an increased potential of plasma species to penetrate complex biofilm matrices further inactivating the cells. However, there

are several limitations in this work. It has been known that formation of biofilms is influenced by environmental conditions and characteristics of substrates to which bacteria attach. In this study the model system, a 96 well microtiter plate, was utilised for biofilm development, which cannot holistically describe the broad range of materials implicated in biofilm formation within clinical environments and industrial settings. Moreover, it is more likely that in real industrial and clinical settings biofilm communities may be inhabited by numerous different species and interactions between these species could contribute to the organization of multispecies biofilms. Multispecies biofilms are usually more resistant against antimicrobial treatments than monospecies biofilms (Yang *et al.* 2011). Therefore, based on the results discussed here, further studies on the efficacy of ACP against multispecies biofilms developed on a wider range of relevant materials are warranted.

P. aeruginosa has diverse pathogenicity and resistance to broad spectrum antibiotic treatments (Venier *et al.* 2014). The resistance of *P. aeruginosa* to antimicrobials is generally attributed to the reduced cell wall permeability, active multidrug efflux systems, biofilm formation, plasmid acquisition and mutation due to the stress encountered from continuous antibiotic use (Lambert 2002; Jimenez *et al.* 2012). Inhibition of QS-controlled virulence factors is a novel approach with a potential to decrease or substitute the use of traditional antibiotics, by providing minimal bacterial stress and thus decreased resistance development. Recent investigations of the effects of natural and chemically synthesised compounds have demonstrated that reduction of virulence factor production and prevention of biofilm formation

with aims to control microbial infection is possible through inhibition of one or more components of the QS system (Cathcart *et al.* 2011; Vandeputte *et al.* 2011; Amaya *et al.* 2012; Cady *et al.* 2012; O'Loughlin *et al.* 2013; El-Mowafy *et al.* 2014). Unfortunately, many known QS inhibition compounds are cytotoxic, which limits their applications in mammalian cells (Brackman and Coyen 2015). The potential of ACP treatment to interfere with virulence of *P. aeruginosa* was recently demonstrated by Vandervoort and Brelles-Marino (2014), which showed attenuated bacterial virulence after longer treatment duration as tested by the lettuce assay. Therefore, based on the literature and the results of our previous studies further investigations were focused on whether this technology is capable of interfering with *P. aeruginosa* QS-controlled virulence factors, such as pyocyanin and extracellular elastase (Las B) and as a consequence affect biofilm formation. Thus, in the current study, in order to rule out any underlying bactericidal effects of ACP, the changes in the planktonic cell population density were monitored by conducting colony count assay following treatment. Short treatment time of 60 s in conjunction with either type of exposure significantly reduced *P. aeruginosa* *rhl*-regulated pyocyanin levels, which were retained during 24 h of post treatment storage time at room temperature. It is known that atmospheric air ACP is a significant source of multiple reactive oxygen species, including ozone, atomic oxygen, singlet oxygen, superoxide, peroxide, hydroxyl radicals and excited nitrogen species (Moiseev *et al.* 2014; Misra *et al.* 2015). Therefore, it is possible that pyocyanin could undergo oxidation by ROS and RNS generated during ACP treatment. Similar oxidative effects were observed by

Reszka *et al.* (2004, 2010, 2012), which reported irreversible oxidation of pyocyanin by hydrogen peroxide, singlet oxygen and nitrite, significantly reducing its cytotoxic/proinflammatory activity. Another studied virulence factor, elastase (Las B), is mainly under the control of the *las* system and plays an important role in biofilm development (Cathcart *et al.* 2011; Vandeputte *et al.* 2011; Yu *et al.* 2014). While concentrations of pyocyanin were significantly reduced after relatively short treatment times, reduction of extracellular elastase was notable only after extended treatment time and when compared with the 24 h control samples. Importantly, observed reductions of the studied virulence factors were associated with no reduction in the planktonic cell concentration. Reduced bactericidal effects of ACP treatment against planktonic cells could be due to protective effect of TSB where media components are likely to scavenge many of the plasma reactive species generated during the treatment. Hence, these observations could indicate the possible interference of ACP generated reactive species with QS systems involved in the production of virulence factors. While it was hypothesized that the disruption of QS systems could further lead to the reduction in *P. aeruginosa* biofilm formation, no reduction in biofilm formation could be achieved even after extended treatment for 300 s. The QS pathways regulating quorum sensing and biofilm formation are complex and despite the demonstrated activity of ACP against two of *P. aeruginosa*'s virulence factors, the effect on QS system and other biofilm formation mechanisms will need to be addressed in future work.

The toxic effects of *P. aeruginosa* QS-controlled virulence factors on mammalian cells, including elastase and pyocyanin, have been widely reported (Reszka *et al.* 2004; Gellatly *et al.* 2012; Alasil *et al.* 2015). For example, a concentration dependent cytotoxic effect of pyocyanin on different eukaryotic systems was reported by Mohammed *et al.* (2014) and Priyaja *et al.* (2014), whereas *P. aeruginosa las B* mutant strain almost totally abrogated epithelial cell cytotoxicity (Gellatly *et al.* 2012). In this study, ACP-mediated reduction of *P. aeruginosa* virulence factors was associated with significant reduction of cytotoxic effects of bacterial supernatant on CHO-K1 cells regardless of type and duration of treatment. These results indicate the high potential of ACP treatment to attenuate bacterial virulence within relatively short treatment times (60 s), which could be essential in the future research for in vivo ACP applications. However, pronounced decrease in viability of CHO-K1 was observed when cells were exposed to corresponding uninoculated and ACP treated TSB medium. An ACP treatment time dependent reduction of cell viability could be due to the action of ROS and RNS accumulated in the medium during the treatment. Wende *et al.* (2014), exposing human keratinocytes, HaCaT cells, to ACP treated media, found a treatment time dependent increase in accumulation of intracellular ROS. Moreover, intracellular ROS levels strongly depended on the cell culture medium, where small organic molecules such as sugars, amino acids, vitamins and buffer systems could interfere with ROS stability/propagation within the liquid, modifying any plasma effects. In contrast, Haertel *et al.* (2012), exposing HaCaT cells either to air ACP or to the ACP treated media found that the levels of intracellular ROS

induction was neither dependent on the duration of the plasma treatment nor the treatment type. Furthermore, exposure either to ACP treatment or ACP treated media resulted in a comparable reduction in the levels of adherent HaCaT cells. Together with our observations these results indicate the additional treatment effects, which need to be considered in ACP-based research investigating the treatment anti-QS or anti-virulence potential, however, with no exclusion of the suitability of ACP treated fluids for potential application in patients (Haertel *et al.* 2012). It is also important that exposure to treated TSB media significantly reduced the growth of cell as compared to the effects of *P. aeruginosa* supernatants, which could be due to the ROS scavenging properties of multiple components secreted into a medium by this pathogen, including alginate and pigments, such as pyocyanin, pyoverdine and pyorubin (Brun *et al.* 2012). In recent years ACP has been under intense investigation for potential applications in wound healing, blood coagulation and skin regeneration, and apoptosis of cancer cells (Kim *et al.* 2010; Dobrynin *et al.* 2011; Arjunan *et al.* 2012; Brun *et al.* 2012; Emmert *et al.* 2013; Kramer *et al.* 2013; Wu *et al.* 2013; Lunov *et al.* 2014). Apart from ACP-mediated induction of cells proliferation, lethal effects on mammalian cells have been also reported (Kieft *et al.* 2004; Leduc *et al.* 2010). Therefore, further investigations have been initiated with the main focus on the effects of air DBD ACP treatment on viability of cell culture lines of human and animal origin, where the balance between ACP bactericidal action and effects on mammalian cells viability will be the key factor determining the system's potential in medical applications.

It is considered that QS-regulated virulence factors, such as pyocyanin and elastase, play a crucial role in clinical pathogenicity of *P. aeruginosa* (Le Berre *et al.* 2008) and inhibition of these virulence factors is a key element in the future research for the replacement of current antibiotics. To date, this is the first report focusing on anti-virulence activity of ACP, which clearly demonstrated that, although there was no antibiofilm effect observed against *P. aeruginosa* at the parameters examined, the treatment exhibited high potential against *P. aeruginosa* QS-regulated virulence factors and these observations may further serve as a means for exploration of new ACP-based strategies for tackling infections caused by this microorganism.

7.5. Conclusion

This study clearly demonstrated that in-package high voltage air DBD ACP in conjunction with post treatment storage is very effective against established complex bacterial biofilms. With relatively short treatment of 60 s it was possible to achieve substantial reductions ($5.4 \log_{10}$ CFU/ml) of 48 h old *P. aeruginosa* biofilms. In this study a series of methods were utilised to monitor the changes in biofilms caused by ACP treatment, namely, colony count, XTT assay, CLSM and SEM, elucidating information regarding different parameters associated with the viability of cells in biofilms. In terms of metabolic activity, 30% of cells survived extended treatment for 300 s, whereas according to colony count there were no bacterial survivors. These results indicated a possible induction of VBNC state of bacteria due to the stress caused by ACP treatment. However, CLSM and SEM analyses demonstrated that extended treatment caused severe damage to *P.*

aeruginosa cell membranes and effectively disrupted heterogeneous biofilm structures. Importantly, significant reductions of *P. aeruginosa* QS-regulated virulence factors, such as pyocyanin and elastase (Las B) production, were achieved, suggesting that ACP technology could be a potential QS inhibitor and may play an important role in attenuation of virulence of pathogenic bacteria. However, even after 300 s treatment, biofilm formation capacity was largely unaffected, suggesting that the inactivation of virulence factors by ACP could also be independent of QS mechanisms. Further optimization of ACP treatment parameters for successful prevention and inactivation of established and developing biofilms should focus on the mechanisms involved in the ACP-mediated disruption of bacterial QS systems and complete inactivation of VBNC state to reduce the risks associated with cross- or re-contamination during or after treatment. Moreover, better understanding of interactions between plasma ACP reactive species and biofilm components and identification of specific biofilm targets will allow further optimisation of ACP treatment parameters towards more effective and less damaging sterilisation, required in the field of food production and medicine.

Chapter 8: GENERAL CONCLUSIONS AND FUTURE RECOMMENDATIONS

- The antimicrobial efficacy of the ACP technology was investigated utilising two DBD systems, DIT60 and DIT120, differing by the maximum voltage output, 60 and 120 kV, respectively. The optimisation studies using DIT60 system allowed critical control parameters determining antimicrobial activity of high voltage in-package ACP treatment to be established.
- The study revealed that inactivation efficacy of treatment screened against high populations of *E. coli* dispensed in liquid media was affected by the mode of exposure, treatment time, post treatment storage time, voltage levels, working gas and media composition. Some key interactive effects between these parameters were also observed.
- Post treatment storage time emerged as a critical treatment parameter for consistency and efficiency of bacterial inactivation with this type of system. The inactivation efficacy of treatment was optimal when direct atmospheric air generated ACP treatment and an extended post treatment storage time of 24 h was utilised.
- The 24 h of post treatment storage time allowed the retention of plasma generated reactive species inside the pack over a sufficient time prior to dissipation of long lived species, facilitating penetration and bactericidal action of ACP generated reactive species regardless of mode of exposure.

- The effect of media complexity was evident with complete inactivation of cells achieved in media with simpler composition within 10 s of treatment again regardless of mode of exposure.
- DBD system diagnostics using optical emission spectroscopy revealed distinct peaks, which corresponded to strong emission from N_2 and N_2^+ excited species.
- High concentrations of ozone as a major long lived bactericidal species of atmospheric air ACP were recorded even after short treatment durations.
- The potential for air ACP to produce highly reactive oxygen and nitrogen species was proven in the study when aqueous solution of a model basic textile dye, methylene blue, was assessed as a potential indicator of the efficacy of ACP treatments. An efficient degradation of methylene blue within seconds indicated the high potential of DBD ACP system for future applications in wastewater treatment. However, no correlation was found between bacterial reduction and dye degradation, making such an approach unsuitable as a diagnostic tool for microbial behaviour with this system.
- Antimicrobial efficacy of ACP generated on DIT120 increased when voltage level and gas mixture with higher oxygen content (atmospheric air and 65% O_2 + 30% CO_2 + 5% N_2) for generation of plasma was utilised, nullifying the effect of mode of ACP exposure and media composition. Systematic ozone measurements confirmed strong correlation between higher ozone concentrations and increased levels of these treatment variables, i.e. voltage and O_2 levels.

- Despite the varying parameters that influenced plasma bactericidal activity, high voltage in-package atmospheric air ACP decontamination approach showed an efficient reduction of high concentrations of bacteria in liquids regardless mode of exposure utilised. These results represent significant technological advance in non-thermal bactericidal treatment and warrant further investigations where different bacterial types and liquid systems with different chemical complexity levels, gas and liquid volume to efficacy ratio, as well as the type of ACP generated reactive species, their penetration rates and retention time of efficacy could be the potential future research questions.
- High voltage in-package indirect ACP treatment with 24 h of post treatment storage time, selected as a more favourable treatment approach in terms of fresh produce quality retention, was highly effective for decontamination of cherry tomatoes and strawberries inoculated with *Salmonella*, *E. coli* and *L. monocytogenes* monocultures and against background microflora of produce. However, the produce surface characteristics and the contaminating pathogen influenced inactivation effect of ACP.
- Higher inactivation rates were achieved for Gram negative bacteria and bacteria associated with smooth surface of tomatoes, while an extended ACP treatment time was necessary to reduce either bacterial populations attached on the more complex surface of strawberries.
- The produce type influenced the concentration of ozone, where lower ozone levels were recorded for strawberry samples. Strawberries surface

exhibit numerous pores, making the surface contact area larger than the area of tomato surface, which may contribute to the increased dissolution rate of ozone generated inside the strawberry package, with subsequent reduced antimicrobial efficacy of ACP with regard to the all bacteria tested.

- Variations between initial populations of bacteria were apparent, with *Salmonella* and *L. monocytogenes* more readily attaching on the surface of either produce than *E. coli*, which was further confirmed by SEM.
- These results indicate the importance of the type of produce, their inherent surface characteristics, naturally existing indigenous epiphytic bacterial communities, the type of contaminating pathogen, mechanisms and strengths of bacterial attachment with respect to future system optimisation procedures.
- The antimicrobial potential of high voltage either direct or indirect in-package atmospheric air ACP treatment with subsequent 24 h of storage was proven to be effective for inactivation of pathogens in the form of monoculture biofilms commonly implicated in foodborne and healthcare associated human infections, *E. coli*, *L. monocytogenes*, *S. aureus*, *P. aeruginosa* established during 48 h on abiotic surface. However, the efficiency of ACP treatment was bacterial type and shape dependant. These effects of ACP treatment related to bacterial morphology remain unclear and warrant further investigations but are not necessarily surprising given the varying effects of cell membrane characteristics on antimicrobial efficacy.

- The results obtained from XTT assay demonstrated that complete inactivation of metabolic activity of Gram negative *E. coli* could not be achieved even after extended treatment for 300 s indicating that bacteria possibly entered VBNC state due to oxidative stress encountered from chemically reactive species generated by ACP.
- The SEM analysis confirmed destructive action of ACP. However, intact cells were found after exposure to ACP, indicating possible retention of cell metabolic activity, i.e. presence in their VBNC state.
- Although significant reduction of the reproducibility and metabolic activity of cells in monoculture biofilms was achieved by action of ACP, further studies are required, which will focus on the efficacy of ACP against multispecies biofilms developed on a wider range of different materials relevant to the real industrial and clinical settings in order to holistically describe antimicrobial effects of treatment.
- In-package high voltage indirect ACP treatment was very effective against planktonic populations of *Salmonella*, *L. monocytogenes* and *E. coli* suspended in model media, lettuce broth. However, an extended treatment was required to attain substantial reductions of these pathogens attached to lettuce surfaces as an example of complex organic surface.
- Concentrations of ROS estimated by DCFH-DA assay were higher inside bacterial cells suspended in more simple media, such as PBS, as compared to the concentrations of ROS recorded for cells treated in lettuce broth proving the hypothesis that organic components, such as proteins and

vitamins, may scavenge many of the plasma generated reactive species thus posing a protective effect against antimicrobial action of reactive species generated during the treatment.

- These studies also demonstrated that produce storage conditions common in the distribution chain, such as temperature, light and storage time had interactive effects on bacterial proliferation, stress response and susceptibility to the ACP treatment.
- For instance, bacterial biofilms developed on lettuce at room temperature in a light/dark photoperiod during 48 h, exhibited higher resistance to ACP than 24 h biofilms. In contrast, biofilms developed at 4°C in combination with either light storage condition during 48 h were more susceptible to the treatment than 24 h old biofilms.
- CLSM analysis of inoculated untreated lettuce suggests that light conditions during produce distribution may promote bacterial internalisation thereby significantly impacting the effectiveness of ACP.
- SEM analysis demonstrated that high voltage in-package ACP treatment in conjunction with 24 h of post treatment storage had detrimental effects on unprotected bacteria, eliminating most of the cells from the surface of lettuce. However, inside stomata, where high concentrations of cells were noted and strong biofilm formation is anticipated, bacterial cells remained intact, suggesting that ACP generated reactive species were not able to penetrate colonized stomata through the complex biofilm matrices.

- The results highlight the importance of informed effective microbiological control as microorganisms protected by biofilms and/or the complex structures of different produce commodities may present major risks of cross-contamination of the environment in food production sites.
- Preventive measures such as maintenance of the appropriate temperature regimes and minimised light exposure throughout produce distribution chain are extremely important factors for the assurance of microbiological safety of fresh produce.
- Further research is needed to focus on the effects of pre-treatment storage conditions in order to understand bacterial behaviour, adaptation to stress, development of cross protection and the corresponding response to ACP treatment in order to further optimise plasma treatment parameters for the consistent inactivation of pathogens on or in produce where enhanced produce quality characteristics are also attained.
- A comprehensive study was conducted on inactivation of the 48 h old *P. aeruginosa* biofilms established on abiotic surface where a series of methods were utilised to monitor the changes in biofilms caused by ACP treatment, elucidating information regarding different parameters associated with the viability of cells in biofilms.
- The results obtained from XTT assay indicated a possible induction of VBNC state of bacteria due to the stress caused by ACP treatment. However, colony count, CLSM and SEM analyses demonstrated that ACP treatment completely inactivated cells and caused severe damage to *P.*

aeruginosa cell membranes and effectively disrupted heterogenous biofilm structures.

- Significant reductions of *P. aeruginosa* QS-regulated virulence factors were achieved with no concomitant reduction in the planktonic cell population density. Production of pyocyanin was significantly inhibited after relatively short treatment times, whereas reduction of extracellular elastase was notable only after extended treatment time. Despite the demonstrated activity of ACP against studied virulence factors, the effect on other factors and mechanisms will need to be addressed.
- ACP-mediated reduction of *P. aeruginosa* virulence factors was associated with significant reduction of cytotoxic effects of bacterial supernatant on CHO-K1 cells regardless type and duration of treatment. These observations indicate the high potential of ACP treatment to attenuate bacterial virulence within relatively short treatment times, which could be essential in the future research for *in vivo* ACP applications.
- An unfavourable decrease in viability of CHO-K1 was observed when cells were exposed to uninoculated and ACP treated TSB medium. Therefore, further investigations are required with the main focus on the effects of ACP treatment on viability of cell culture lines of human and animal origin, where the balance between ACP bactericidal and anti-QS actions and effects on mammalian cells viability will be the key factor determining the system's potential in medical applications.

- Further studies for the successful prevention and inactivation of established and developing biofilms should focus on the mechanisms involved in the ACP-mediated disruption of bacterial QS systems and complete inactivation of VBNC state to reduce the risks associated with virulence and cross- or re-contamination during or after treatment.
- A better understanding of interactions between plasma ACP reactive species and biofilm structural components and identification of specific biofilm targets will allow further optimisation of ACP treatment parameters towards more effective and less damaging sterilisation, required in the field of food production and medicine.

References

- Abadias, M., Usall, J., Anguera, M., Solsona, C. and Viñas, I. (2008). Microbiological quality of fresh, minimally-processed fruit and vegetables, and sprouts from retail establishments. *International Journal of Food Microbiology*, 123, 121-129.
- Adonizio, A., Kong, K.F. and Mathee, K. (2008). Inhibition of QS-controlled virulence factor production in *Pseudomonas aeruginosa* by outh Florida plant extracts. *Antimicrobial agents and chemotherapy*, 52, 198-203.
- Al-Nabulsi, A.A., Osaili, T.M., Shaker, R.R., Olaimat, A.N., Jaradat, Z.W., Elabedeen, N.A.Z. and Holley, R.A. (2015). Effects of osmotic pressure, acid, or cold stresses on antibiotic susceptibility of *Listeria monocytogenes*. *Food Microbiology*, 46, 154 – 160.
- Alam, M.J. and Zurek, L. (2004). Association of *Escherichia coli* O157:H7 with Houseflies on a Cattle Farm. *Applied Environmental Microbiology*, 70, 7578–7580.
- Alasil, S.M., Omar, R., Ismail, S. and Yusof, M.Y. (2015). Inhibition of Quorum Sensing-Controlled Virulence Factors and Biofilm Formation in *Pseudomonas aeruginosa* by Culture Extract from Novel Bacterial Species of *Paenibacillus* Using a Rat Model of Chronic Lung Infection. *International Journal of Bacteriology*, 2015, 1 – 16. doi: 10.1155/2015/671562
- Alexopoulos, A., Plessas, S., Cechiu, S., Lazar, V., Mantzourani, I., Voidarou, C., Stavropoulou, E. and Bezirtzoglou, E. (2013). Evaluation of ozone efficacy on

- the reduction of microbial population of fresh cut lettuce (*Lactuca sativa*) and green bell pepper (*Capsicum annuum*). *Food Control*, 30, 491-496.
- Alkawareek, M.Y., Algwari, Q.T., Graham, B., Gorman, S., O'Connell, D. and Gilmore, B. (2012a). Application of atmospheric pressure nonthermal plasma for the in vitro eradication of bacterial biofilms. *FEMS Immunology and Medical Microbiology*, 65, 381–384.
- Alkawareek, M.Y., Algwari, Q.T., Lavery, G., Gorman, S.P., Graham, W.G., O'Connell, D. and Gilmore, B.F. (2012b). Eradication of *Pseudomonas aeruginosa* Biofilms by Atmospheric Pressure Non-Thermal Plasma. *PLoS ONE* 7(8): e44289. doi:10.1371/journal.pone.0044289.
- Allende, A., Tomas-Barberan F.A. and Gil, M.I. (2006). Minimal processing for healthy traditional foods. *Trends in Food Science & Technology*, 17, 513–519.
- Allydice-Francis, K. and Brown, P. (2012). Diversity of Antimicrobial Resistance and Virulence Determinants in *Pseudomonas aeruginosa* Associated with Fresh Vegetables. Hindawi Publishing Corporation. *International Journal of Microbiology*, 2012, 1 – 7, ID 426241, doi:10.1155/2012/426241.
- Amaya, S., Pereira, J.A., Borkosky, S.A., Valdez, J.C., Bardón, A. and Arena, M.E. (2012). Inhibition of quorum sensing in *Pseudomonas aeruginosa* by sesquiterpene lactones. *Phytomedicine*, 19, 1173 – 1177.
- Arjunan, K. P. and Clyne, A. M. (2011). Hydroxyl radical and hydrogen peroxide are primarily responsible for dielectric barrier discharge plasma induced angiogenesis. *Plasma process and polymers*, 8, 1154 – 1164.

- Arjunan, K.P., Friedman, G., Fridman, A. and Clyne, A.M. (2012). Non-thermal dielectric barrier discharge plasma induces angiogenesis through reactive oxygen species. *Journal of Royal Society Interface*, 9, 147–157.
- Awuah, G.B., Ramaswamy, H.S. and Economides, A. (2007). Thermal processing and quality: Principles and overview. *Chemical Engineering and Processing*, 46, 584–602.
- Ayrapetyan, M., Williams, T.C. and Oliver, J.D. (2015). Bridging the gap between viable but non-culturable and antibiotic persistent bacteria. *Trends in Microbiology*, 23, 7 – 13.
- Back, S.Y., Jin, H.H. and Lee, S.Y. (2009). Inhibitory effect of organic acids against *Enterobacter sakazakii* in laboratory media and liquid foods. *Food Control*, 20, 867–872.
- Bai, A.J. and Rai, V.R. (2011). Bacterial Quorum Sensing and Food Industry. *Comprehensive Reviews in Food Science and Food Safety*, 10, doi 10.1111/j.1541-4337.2011.00150.x.
- Baier, M., Foerster, J., Schnabel, U., Knorr, D., Ehlbeck, J., Herppich, W.B. and Schlüter, O. (2013). Direct non-thermal plasma treatment for the sanitation of fresh corn salad leaves: Evaluation of physical and physiological effects and antimicrobial efficacy. *Postharvest Biology and Technology*, 84, 81–87.
- Baier, M., Ehlbeck, J., Knorr D., Herppich, W.B. and Schlüter, O. (2015b). Impact of plasma processed air (PPA) on quality parameters of fresh produce. *Postharvest Biology and Technology*, 100, 120–126.

- Baier, M., Janßen, T., Wieler, L.H., Ehlbeck, J., Knorr, D. and Schlüter, O. (2015a). Inactivation of Shiga toxin-producing *Escherichia coli* O104:H4 using cold atmospheric pressure plasma. *Journal of Bioscience and Bioengineering*, doi:10.1016/j.jbiosc.2015.01.003.
- Baier, M., Görgen, M., Ehlbeck, J., Knorr D., Herppich, W.B. and Schlüter, O. (2014). Non-thermal atmospheric pressure plasma: Screening for gentle process conditions and antibacterial efficiency on perishable fresh produce. *Innovative Food Science and Emerging Technologies*, 22, 147–157.
- Banu, M.S., Sasikala, P., Kavitha, V. and Rajamani, L. (2012). Cold plasma as a novel food processing technology. *International Journal of Emerging trends in Engineering and Development*, 2, 803 – 818.
- Bardos, L. and Barankova, H. (2010). Cold atmospheric plasma: Sources, processes, and applications. *Thin Solid Film*, 518, 6705-6713.
- Barria, C., Malecki, M. and Arraiano, C.M. (2013). Bacterial adaptation to cold. *Microbiology*, 159, 2437–2443.
- Barth, M., Hankinson, T.R., Zhuang, H. and Breidt, F. (2011). Microbiological spoilage of Fruits and Vegetables. In *Compendium of the Microbiological Spoilage of Foods and Beverages*, Food Microbiology and Food Safety. Ed. Sperber, W.H. and Doyle, M.P. DOI 10.1007/978-1-4419-0826-1_6.
- Beales, N. (2004). Adaptation of microorganisms to cold temperatures, weak acid preservatives, low pH, and osmotic stress: A review. *Comprehensive review in food science and food safety*, 3, 1 – 20.

- Belessi, C.E.A., Gounadaki, A.S, Psomas, A.N and Skandamis, P.N. (2011). Efficiency of different sanitation methods on *Listeria monocytogenes* biofilms formed under various environmental conditions. *International Journal of Food Microbiology*, 145, S46-S52.
- Berger, C. N., Sodha, S. V., Shaw, R. K., Griffin, P. M., Pink, D., Hand, P. and Frankel, G. (2010). Fresh fruit and vegetables as vehicles for the transmission of human pathogens. *Environmental Microbiology*, 12, 2385–2397.
- Bermúdez-Aguirre, D., Wemlinger, E., Pedrow, P., Barbosa-Cánovas, G. and Garcia-Perez, M. (2013). Effect of atmospheric pressure cold plasma (APCP) on the inactivation of *Escherichia coli* in fresh produce. *Food Control*, 34, 149-157.
- Bett-Garber, K.L., Greene, J.L., Lamikanra, O., Ingram, D.A., Watson, M.A. (2011). Effect of storage temperature variations on sensory quality of fresh-cut cantaloupe melon. *Journal of Food Quality*, 34, 19–29.
- Beuchat, L.R. (1998). Surface Decontamination of Fruits and Vegetables Eaten Raw: A Review, Food Safety Issues, Food Safety Unit. World Health Organization, Geneva. WHO/FSF/FOS/98.2. Available at: http://www.who.int/foodsafety/publications/fs_management/en/surface_decon.pdf [accessed on 15 June 2013].
- Bhardwaj, A.K., Vinothkumar, K. and Rajpara, N. (2013). Bacterial Quorum Sensing Inhibitors: Attractive Alternatives for Control of Infectious Pathogens Showing Multiple Drug Resistance. *Recent Patents on Anti-Infective Drug Discovery*, 8, 68 - 83.

- Bocci, V., Zanardi, I. and Travagli, V. (2011). Oxygen/ozone as a medical gas mixture. A critical evaluation of the various methods clarifies positive and negative aspects. *Medical gas research*, 1, 6.
- Bodur, T. and Cagri-Mehmetoglu, A. (2012). Removal of *Listeria monocytogenes*, *Staphylococcus aureus* and *Escherichia coli* O157:H7 biofilms on stainless steel using scallop shell powder. *Food Control*, 25, 1 – 9.
- Borges, A., Simões, L.C., Saavedra, M.J., Simõe, M. (2013). The action of selected isothiocyanates on bacterial biofilm prevention and control. *International journal of Biodeterioration and Biodegradation*, 86, 25-33.
- Brackman, G. and Coenye, T. (2015). Quorum Sensing Inhibitors as Anti-Biofilm Agents. *Current Pharmaceutical Design*, 21, 5 – 11.
- Brelles-Marino, G. (2012). Challenges in biofilm Inactivation: the use of cold plasma as a new approach. *Journal of Bioprocessing and biotechniques*, 2:e 107. doi: 10.4172/2155-9821.1000e107.
- Bridier, A., Sanchez-Vizueté, P. Guilbaud, M., Piard, J.C., Naïtali, M.R. and Briandet, R. (2015). Biofilm-associated persistence of food-borne pathogens. *Food Microbiology*, 45, 167–178.
- Brun, P., Brun, P., Vono, M., Venier, P., Tarricone, E., Deligianni, V., Martines, E., Zuin, M., Spagnolo, S., Cavazzana, R., Cardin, R., Castagliuolo, I., La Gloria Valerio, A. and Leonardi, A. (2012). Disinfection of Ocular Cells and Tissues by Atmospheric Pressure Cold Plasma. *PLoS ONE*, 7, e33245. doi:10.1371/journal.pone.0033245.

- Bryers, J.D. (2008). Medical Biofilms. *Biotechnology and Bioengineering*, 100, 1–18. doi:10.1002/bit.21838.
- Buck, J.W., Walcott, R.R. and Beuchat, L.R. (2003). Recent Trends in Microbiological Safety of Fruits and Vegetables. *Plant Health Progress* doi:10.1094/PHP-2003-0121-01-RV. Available at <http://www.apsnet.org/> [Accessed on 12 November 2014].
- Burlica, R., Kirkpatrick, M.J. and Locke, B.R. (2006). Formation of reactive species in gliding arc discharges with liquid water. *Journal of electrostatics*, 64, 35 – 43.
- Cabiscol, E., Tamarit, J. and Ros, J. (2000). Oxidative stress in bacteria and protein damage by reactive oxygen species. *International Microbiology*, 3, 3–8.
- Cady, N.C., McKean, K.A., Behnke, J., Kubec, R., Mosier, A.P., Kasper, S.H., Burz, D.S. and Musah, R.A. (2012). Inhibition of Biofilm Formation, Quorum Sensing and Infection in *Pseudomonas aeruginosa* by Natural Products-Inspired Organosulfur Compounds. *PLoS ONE*, 7, 38492.
- Carrasco, E., Morales-Rueda, A. and García-Gimeno, R.M. (2012). Cross-contamination and recontamination by *Salmonella* in foods: A review. *Food Research International*, 45, 545–556.
- Cathcart, G.R.A., Quinn, D., Greer, B., Harriott, P., Lynas, J. F. Gilmore, B.F. and Walker, B. (2011). Novel Inhibitors of the *Pseudomonas aeruginosa* Virulence Factor LasB: a Potential Therapeutic Approach for the Attenuation of Virulence Mechanisms in Pseudomonas Infection. *Antimicrobial agent and chemotherapy*, 55, 2670–2678.

- Cebrian, G., Sagarzazu, N., Pagán, R., Condón, S. and Mañas, P. (2010). Development of stress resistance in *Staphylococcus aureus* after exposure to sublethal environmental conditions. *International Journal of Food Microbiology*, 140, 26–33.
- Centres for Disease Control and Prevention (CDC). (2012). Multistate Outbreak of Listeriosis Linked to Whole Cantaloupes from Jensen Farms, Colorado. Available at <http://www.cdc.gov/listeria/outbreaks/cantaloupes-jensen-farms/082712/index.html> [Accessed on 26 March 2013].
- Chen, L., Wei, Y., Zuo, X., Cong, J. and Meng, Y. (2012). The atmospheric pressure air plasma jet with a simple dielectric barrier. *Thin solid Films*, 521, 226–228.
- Cheruthazhekatt, S., Cernák, M., Slavíček, P. and Havel, J. (2010). Gas plasmas and plasma modified materials in medicine. *Journal of Applied Medicine*, 8, 55-66.
- Chiang, M.H., Wu, J.Y., Li, Y.H. Wu, J.S., Chen, S.H. and Chang, C.L. (2010). Inactivation of *E. coli* and *B. subtilis* by a parallel-plate dielectric barrier discharge jet. *Surface & Coatings Technology*, 204, 3729–3737.
- Chiang, S.M. and Schellhorn, H.E. (2012). Regulators of oxidative stress response genes in *Escherichia coli* and their functional conservation in bacteria. *Archives of Biochemistry and Biophysics*, 525, 161–169.
- Chirokov, A., Gustol, A. and Fridman, A. (2005). Atmospheric pressure plasma of dielectric barrier discharge. *Pure Applied Chemistry*, 2, 487-495.

- Choi, M.R., Lee, S.Y., Park, K.H., Chung, M.S., Ryu, S.R. and Kang, D.H. (2012). Effect of aerosolized malic acid against *Listeria monocytogenes*, *Salmonella Typhimurium*, and *Escherichia coli* O157:H7 on spinach and lettuce. *Food Control*, 24, 171-176.
- Conrads, H. and Schmidt, M. (2000). Plasma generation and plasma sources. *Plasma Sources Sci. Technology* 9, 441 – 454.
- Cooley, M.B, Chao, D. and Mandrell, R.E. (2006). *Escherichia coli* O157:H7 survival and growth on lettuce is altered by the presence of epiphytic bacteria. *Journal of food protection*, 69, 2329-2335.
- Costerton, J.W. and Lewandowski, Z. (1995). Microbial biofilms. *Annual Review microbiology*, 49, 711-45.
- Cotter, J.J., Maguire, P., Soberon, F., Daniels, S., O’Gara, J.P. and Casey, E. (2011). Disinfection of meticillin-resistant *Staphylococcus aureus* and *Staphylococcus epidermidis* biofilms using a remote non-thermal gas plasma. *Journal of Hospital Infection*, 78, 204-207.
- Critzer, M., Kelly-Wintenberg, K., South, S. and Golden, D. (2007). Atmospheric plasma inactivation of foodborne pathogens on fresh produce surfaces. *Journal of food protection*, 70, 2290.
- Dai, Q., Borenstein, A.R., Wu, Y. Jackson, J.C. and Larson, E.B. (2006). Fruit and Vegetable Juices and Alzheimer’s Disease: The *Kame* Project. *The American Journal of Medicine*, 119, 751-759.
- Das, E., Gürakan, G.C. and Bayindirli, A. (2006). Effect of controlled atmosphere storage, modified atmosphere packaging and gaseous ozone treatment on the

- survival of *Salmonella* Enteritidis on cherry tomatoes. *Food Microbiology*, 23, 430 - 438.
- De Kievit, T.R. (2009). Quorum sensing in *Pseudomonas aeruginosa* biofilms. *Environmental Microbiology*, 11, 279–288.
- Deering, A.J., Mauer, L.J. and Pruitt, R.E. (2012). Internalization of *E. coli* O157:H7 and *Salmonella* spp. in plants: A review. *Food Research International*, 45, 567–575.
- Delaquis, P. and Bach, S. (2012). Resistance and sublethal damage. Produce contamination. In *Decontamination of Fresh and Minimally Processed Produce*. Ed. Gomez-Lopez, V. M., Wiley-Blackwell Publishing, USA, pp. 77 - 89.
- Demirkol, O., Cargi-Mehmetoglu, A., Qiang, Z., Ercal, N. and Adams, C. (2008). Impact of food disinfection on beneficial biophilic contents in strawberry. *Journal of agriculture and food chemistry*, 56, 10414–10421.
- Dinu, L.D. and Bach, S. (2011). Induction of Viable but Nonculturable *Escherichia coli* O157:H7 in the Phyllosphere of Lettuce: a Food Safety Risk Factor. *Applied and Environmental Microbiology*, 77, 8295–8302.
- Dobrynin, D., Fridman, D., Friedman, G. and Fridman, A. (2009). Physical and biological mechanisms of direct plasma interaction with living tissue. *New Journal of Physics*, 11, 1 – 26.
- Dobrynin, D., Wasko, K., Friedman, G., Fridman, A. and Fridman, G. (2011). *Plasma Medicine*, 1, 241–247.

- Dodd, C.E.R. Richards, P.J. and Aldsworth, T.G. (2007). Suicide through stress: A bacterial response to sub-lethal injury in the food environment. *International Journal of Food Microbiology*, 120, 46–50.
- Dolezalova, E. and Lukes, P. (2015). Membrane damage and active but nonculturable state in liquid cultures of *Escherichia coli* treated with an atmospheric pressure plasma jet. *Bioelectrochemistry*, 103, 7–14.
- Donlan, R.M. (2002). Biofilms: Microbial life on surfaces. *Emerging Infectious Diseases*, 8, 9.
- Doring, G. (2010). Prevention of *Pseudomonas aeruginosa* infection in cystic fibrosis patients. *International Journal of Medical Microbiology*, 300, 573-577.
- Ehlbeck, J., Schnabel, U., Polak, M., Winter, J. von Woedtke, T., Brandenburg, R., von dem Hagen, T. and Weltmann, K.D. (2011). Low Temperature Atmospheric Pressure Plasma Sources for Microbial Decontamination. *Journal of Physics D: Applied Physics*, 44. Available at <http://iopscience.iop.org/0022-3727/44/1/013002> [Accessed on 1 July 2013].
- El-Mowafy, S.A., El-Galil, K.H.A., El-Messery, S.M. and Shaaban, M.I. (2014). Aspirin is an efficient inhibitor of quorum sensing, virulence and toxins in *Pseudomonas aeruginosa*. *Microbial Pathogenesis*, 74, 25 – 32.
- Emmert, S., Brehmer, F., Hanßle, H., Helmke, A., Mertens, N., Ahmed, R., Simon, D., Wandke, D., Maus-Friedrichs, W., Daschlein, G., Schon, M.P. and Viol, W. (2013). Atmospheric pressure plasma in dermatology: Ulcus treatment and much more. *Clinical Plasma Medicine*, 1, 24-29.

- Erickson, M.C. (2012). Microbial ecology. Produce contamination. In Decontamination of Fresh and Minimally Processed Produce. Ed. Gomez-Lopez, V. M. USA: Wiley-Blackwell Publishing, pp. 3-29.
- Ermolaeva, S.A., Varfolomeev, A.F., Chernukha, M. Yu., Yurov, D.S., Vasiliev, M.M., Kaminskaya, A.A., Moisenovich, M.M., Romanova, J.M., Murashev, A.N., Selezneva, I.I., Shimizu, T., Sysolyatina, E.V., Shaginyan, I.A., Petrov, O.F., Mayevsky, E.I., Fortov, V.E., Morfill, G.E., Naroditsky, B.S. and Gintsburg, A.L. (2011). Bactericidal effects of non-thermal argon plasma in vitro, in biofilms and in the animal model of infected wounds. *Journal of Medical Microbiology*, 60, 75–83.
- Fakruddin, Md., Shahnewaj, K., Mannan, B. and Andrews, S. (2013). Viable but Nonculturable Bacteria: Food Safety and Public Health Perspective. Review article. Hindawi Publishing Corporation ISRN, *Microbiology*, 2013, 1 – 6, ID 703813, <http://dx.doi.org/10.1155/2013/703813>.
- Fan, X., Sokorai, K.J., Engemann, J., Gurtler, J.B. and Liu, Y. (2012). Inactivation of *Listeria innocua*, *Salmonella* Typhimurium, and *Escherichia coli* O157:H7 on surface and stem scar areas of tomatoes using in-package ozonation. *Journal of Food Protection*, 75, 1611-1618.
- FDA. (2009). Analysis and Evaluation of Preventive Control Measures for the Control and Reduction/Elimination of Microbial Hazards on Fresh and Fresh-Cut Produce. Chapter V. Methods to Reduce/Eliminate Pathogens from Produce and Fresh-Cut Produce. Available at <http://www.fda.gov/> [Accessed on 04 April 2012].

- Fernandez-Delgado, M., Garcia-Amado, M.A., Contreras, M., Incani, R.N., Chirinos, H., Rojas, H. and Suarez, P. (2015). Survival, induction and resuscitation of *Vibrio cholerae* from the viable but non-culturable state in the southern Caribbean sea. *Revista do Insituto de Medicina tropical de Sao Paulo (Journal of the Institute of Tropical Medicine of São Paulo)*, 57, 21-26.
- Fernandez, A. and Thompson, A. (2012). The inactivation of *Salmonella* by cold atmospheric plasma treatment. *Food Research International*, 45, 678 – 684.
- Fernandez, A., Noriega, E. and Thompson, A. (2013). Inactivation of *Salmonella enterica* serovar Typhimurium on fresh produce by cold atmospheric gas plasma technology. *Food Microbiology*, 33, 24 – 9.
- Fernandez, A., Shearer, N., Wilson, D.R. and Thompson, A. (2012). Effect of microbial loading on the efficiency of cold atmospheric gas plasma inactivation of *Salmonella enterica* serovar Typhimurium. *International Journal of Food Microbiology*, 152, 175 – 180.
- Flessa, S., Lusk, D.M. and Harris, L.J. (2005). Survival of *Listeria monocytogenes* on fresh and frozen strawberries. *International Journal of Food Microbiology*, 101, 255– 262.
- Forshell, L.P. and Wierup. M. (2006). Salmonella contamination: a significant challenge to the global marketing of animal food products. *Revue scientifique et technique. International office of epizootics*, 25, 541-554.
- Francis, G.A., Gallone, A., Nychas, G.J., Sofos, J.N., Colelli, G., Amodio, M.L. and Spano, G. (2012). Factors affecting quality and safety of fresh-cut produce. *Critical Reviews in Food Science and Nutrition*, 52, 595-610.

- Fricke, K., Koban, I., Tresp, H., Jablonowski, L., Schroder, K., Kramer, A., Weltmann, K.D., von Woedtke, T. and Kocher, T. (2012). Atmospheric Pressure Plasma: A High-Performance Tool for the Efficient Removal of Biofilms. *PLoS ONE*, 7(8): e42539. doi:10.1371/journal.pone.0042539.
- Fridman, G., Brooks, A.D. Balasubramanian, M., Fridman, A., Gutsol, A., Vasilets, V.N., Ayan, H. and Friedman, G. (2007). Comparison of Direct and Indirect Effects of Non-Thermal Atmospheric-Pressure Plasma on bacteria. *Plasma Processes and Polymers*, 4, 370–375.
- Frohling, A., Baier, M., Ehlbeck, J., Knorr, D. and Schluter, O. (2012a) Atmospheric pressure plasma treatment of *Listeria innocua* and *Escherichia coli* at polysaccharide surfaces: inactivation kinetics and flow cytometric characterisation. *Innovative food science and emerging technologies* 13, 142 – 150.
- Frohling, A., Durek, J., Schnabel, U., Ehlbeck, J., Bolling, J. and Schlüter, O. (2012b). Indirect plasma treatment of fresh pork: Decontamination efficiency and effects on quality attributes. *Innovative Food Science & Emerging Technologies*, 16, 381–390.
- Fujii, A., Seki, M., Higashiguchi, M., Tachibana, I., Kumanogoh, A. and Tomono, K. (2014). Community-acquired, hospital-acquired, and healthcare-associated pneumonia caused by *Pseudomonas aeruginosa*. *Respiratory Medicine Case Reports*, 12, 30-33.
- Gallagher, M.J. Jr, Vaze, N., Gangoli, S., Vasilets, V.N., Gutsol, A.F., Milovanova, T.N., Anandan, S., Murasko, D.M. and Fridman, A.A. (2007). Rapid

- Inactivation of Airborne Bacteria Using Atmospheric Pressure Dielectric Barrier Grating Discharge. *IEEE Transaction on Plasma Science*, 35, 1501-1510.
- Gellatly, S.L., Needham, B., Madera, L., Trent, M.S. and Hancock, R.E.W. (2012). The *Pseudomonas aeruginosa* PhoP-PhoQ Two-Component Regulatory System Is Induced upon Interaction with Epithelial Cells and Controls Cytotoxicity and Inflammation. *Infection and Immunity*, 80, 3122–3131.
- Giaouris, E., Heir, E., Hébraud, M., Chorianopoulos, N., Langsrud, S., Møretrø, T., Habimana, O., Desvaux, M., Renier, S. and Nychas, G.J. (2013). Attachment and biofilm formation by foodborne bacteria in meat processing environments: Causes, implications, role of bacterial interactions and control by alternative novel methods. *Meat Science*, 97, 298–309.
- Gil, M.I. and Allende, A. (2012). Minimal processing. Produce contamination. In Decontamination of Fresh and Minimally Processed Produce. Ed. Gomez-Lopez, V. M., Wiley-Blackwell Publishing, USA, pp. 105 - 116.
- Golberg, D., Kroupitski, Y., Belausov, E., Pinto, R. and Sela, S. (2011). *Salmonella* Typhimurium internalization is variable in leafy vegetables and fresh herbs. *International Journal of Food Microbiology*, 145, 250–257.
- Gomez-Lopez, V.M., Marin, A., Allende, A., Beuchat, L. and Gill, M.I. (2013). Postharvest handling conditions affect internalization of *Salmonella* in baby spinach during washing. *Journal of Food protection*, 76, 1145 – 1151.
- Goodburn, C. and Wallace, C.A. (2013). The microbiological efficacy of decontamination methodologies for fresh produce: A review. *Food Control*, 32, 418-427.

- Gopal, A., Coventry, J., Wan, J., Roginski, H. and Ajlouni, S. (2010). Alternative disinfection techniques to extend the shelf life of minimally processed iceberg lettuce. *Food Microbiology*, 27, 210–219.
- Grabowski, L.R., van Veldhuizen, E.M., Pemen, A.J. M. and Rutgers, W. R. (2007). Breakdown of methylene blue and methyl orange by pulsed corona discharge. *Plasma Sources Science Technology*, 16, 226; doi:10.1088/0963-0252/16/2/003.
- Gram, L., Ravna, L., Rasch, M., Bruhn, J.B., Christensen, A.B and Givskov, M. (2002). Food spoilage—interactions between food spoilage bacteria. *International Journal of Food Microbiology*, 78, 79–97.
- Gratao, P.L., Monteiro, C.C., Rossi, M.L., Martinelli, A.P., Peresc, L.E.P., Medici, L.O., Lea, P.J. and Azevedo, R.A. (2009). Differential ultrastructural changes in tomato hormonal mutants exposed to cadmium. *Environmental and Experimental Botany*, 67, 387–394.
- Griffiths, M. (2005). Quorum-sensing and virulence in food borne pathogens. In Understanding pathogen behaviour. Virulence, stress response and resistance. England :Woodhead Publishing Limited, pp. 549–597.
- Gu, G., Cevallos-Cevallos, J.M. and van Bruggen, A.H.C. (2013b). Ingress of *Salmonella enterica* Typhimurium into tomato leaves through hydathodes. *PLoS ONE*, 8(1): e53470. doi:10.1371/journal.pone.0053470.
- Gu, G., Cevallos-Cevallos, J.M., Vallad, G.E. and van Bruggen, A.H.C. (2013a). Organically managed soils reduce internal colonization of tomato plants by *Salmonella enterica* serovar Typhimurium. *Phytopathology*, 103, 381 – 388.

- Gurung, J., Khyriem, A.B., Banik, A., Lyngdoh, W.V., Choudhury, B. and Bhattacharyya, P. (2013). Association of biofilm production with multidrug resistance among clinical isolates of *Acinetobacter baumannii* and *Pseudomonas aeruginosa* from intensive care unit. *Indian Journal of Critical Care Medicine*, 17, 214-218.
- Guzel-Seydim, Z.B., Greene, A.K. and Seydim, A.C. (2004). Use of ozone in the food industry. *LWT - Food Science and Technology*, 37, 453–460.
- Haertel, B., Hahnel, M., Blackert, S., Wende, K., von Woedtke, T. and Lindequist, U. (2012). Surface molecules on HaCaT keratinocytes after interaction with non-thermal atmospheric pressure plasma. *Cell Biology International*, 36, 1217–1222.
- Han, L., Patil, S., Keener, K., Cullen, P.J. and Bourke, P. (2014). Bacterial inactivation by High Voltage Atmospheric Cold Plasma: Influence of process parameters and effects on cell leakage and DNA. *Journal of Applied Microbiology*, 116, 784–794.
- Harris, L.J., Farber, J.N., Beuchat, L.R., Parish, M.E., Suslow, T.V., Garrett, E.H. and Busta, F.F. (2003). Outbreaks Associated with Fresh Produce: Incidence, Growth, and Survival of Pathogens in Fresh and Fresh-Cut Produce. *Comprehensive Reviews in Food Science and Food Safety*, 2, 78 – 141.
- Hatchette, T., Gupta, R. and Marrie, T. (2000). *Pseudomonas aeruginosa* Community-Acquired Pneumonia in Previously Healthy Adults: Case Report and Review of the Literature. *Clinical Infectious Diseases*, 31, 1349–56.

- Heard, G.M. (2002). Microbiology of fresh-cut produce. In *Fresh-Cut Fruits and Vegetables*. Ed. Lamikanra, O., Science, Technology and Market, pp. 287 – 348.
- Hertwig, C., Reineke, K., Ehlbeck, J., Knorr, D. and Schlüter, O. (2015). Decontamination of whole black pepper using different cold atmospheric pressure plasma applications. *Food Control*, 55, 221-229.
- Huang, F., Chen, L., Wang, H. and Yan, Z. (2010). Analysis of the degradation mechanism of methylene blue by atmospheric pressure dielectric barrier discharge plasma. *Chemical Engineering Journal*, 162, 250–256.
- Huang, Y., and Chen, H. (2011). Effect of organic acids, hydrogen peroxide and mild heat on inactivation of *Escherichia coli* O157:H7 on baby spinach. *Food Control*, 22, 1178–1183.
- Ikawa, S., Kitano, K. and Hamaguchi, S. (2010). Effect of pH on Bacterial Inactivation in Aqueous Solutions due to Low-Temperature Atmospheric Pressure Plasma Application. *Plasma Processes and Polymers*, 7, 33 – 42.
- Ishida, T., Ikeda, T., Takiguchi, N., Kuroda, A., Ohtake, H. and Kato, J. (2007). Inhibition of Quorum Sensing in *Pseudomonas aeruginosa* by N-Acyl Cyclopentylamides. *Applied Environmental Microbiology*, 73, 3183-3188.
- Jahid, I.K., Han, N. and Ha, S.D. (2014a). Inactivation kinetics of cold oxygen plasma depend on incubation conditions of *Aeromonas hydrophila* biofilm on lettuce. *Food Research International*, 55, 181–189.
- Jahid, I.K., Han, N., Zhang, C.Y. and Ha, S.D. (2015). Mixed culture biofilms of *Salmonella Typhimurium* and cultivable indigenous microorganisms on lettuce

- show enhanced resistance of their sessile cells to cold oxygen plasma. *Food Microbiology*, 46, 383 – 394.
- Jahid, I.K., Han, N.R., Srey, S. and Ha, S.D. (2014b). Competitive interactions inside mixed-culture biofilms of *Salmonella* Typhimurium and cultivable indigenous microorganisms on lettuce enhance microbial resistance of their sessile cells to ultraviolet C (UV-C) irradiation. *Food Research International*, 55, 445–454.
- Jensen, B., Knudsen, I.M.B., Andersen, B., Nielsen, K.F., Thrane, U., Jensen, D.F., Larsen, J. (2013). Characterization of microbial communities and fungal metabolites on field grown strawberries from organic and conventional production. *International Journal of Food Microbiology*, 160, 313–322.
- Jeyaletchumi, P., Tunung, R., Margaret, S.P., Son, R., Farinazleen, M.G. and Cheah, Y.K. (2010). Review Article. Detection of *Listeria monocytogenes* in foods. *International Food Research Journal*, 17, 1-11.
- Jimenez, P.N., Koch, G., Thompson, J.A., Xavier, K.B., Cool, R.H. and Quax, W.J. (2012). The Multiple Signaling Systems Regulating Virulence in *Pseudomonas aeruginosa*. *Microbiology and Molecular Biology Reviews*, 76, 46–65.
- Jombo, G.T., Akpan, S., Epoke, J., Denen, A.P. and Odey, F. (2010). Multidrug resistant *Pseudomonas aeruginosa* infections complicating surgical wounds and the potential challenges in managing post-operative wound infections: University of Calabar Teaching Hospital experience. *Asian Pacific Journal of Tropical Medicine*, 3, 479-482.

- Joshi, S.G., Cooper, M., Yost, A., Paff, M., Ercan, U.K., Fridman, G., Fridman, G., Fridman, A. and Brooks, A.D. (2011). Nonthermal dielectric-barrier discharge plasma-induced inactivation involves oxidative DNA damage and membrane lipid peroxidation in *Escherichia coli*. *Antimicrobial Agents and Chemotherapy*, 55, 1053 – 1062.
- Joshi, S.G., Paff, M., Friedman, G., Fridman, G., Fridman, A., and Brooks, A.D. (2010). Control of methicillin-resistant *Staphylococcus aureus* in planktonic form and biofilms: A biocidal efficacy study of nonthermal dielectric-barrier discharge plasma. *American Journal of Infection Control*, 38, 293-301.
- Julak, J., Scholtz, V., Kotucova, S. and Janouskova, O. (2012). The persistent microbiocidal effect in water exposed to the corona discharge. *Physica Medica* 28, 230–239.
- Kadambari, S., Botgros, A., Clarke, P., Vergnano, S., Anthony, M., Chang, J., Collinson, A., Embleton, N., Kennea, N., Settle, P., Heath, P.T. and Menson, E.N. (2014). Characterizing the burden of invasive *Pseudomonas* infection on neonatal units in the UK between 2005 and 2011. *Journal of Hospital Infections*, 88, 109-112.
- Kalia, V.C. (2013). Quorum sensing inhibitors: An overview. *Biotechnology Advances*, 31, 224–245.
- Karatuna, O. and Yagci, A. (2010). Analysis of quorum sensing-dependent virulence factor production and its relationship with antimicrobial susceptibility in *Pseudomonas aeruginosa* respiratory isolates. *Clinical Microbiology and Infections*, 16, 1770-1775.

- Kaszab, E., Szoboszlay, S., Dobolyi, C., Háhn, J., Pék, N. and Kriszt, B. (2011). Antibiotic resistance profiles and virulence markers of *Pseudomonas aeruginosa* strains isolated from composts. *Bioresource Technology*, 102, 1543–1548.
- Keeratipibul, S., Phewpan, A. and Lursinsap, C. (2011). Prediction of coliforms and *Escherichia coli* on tomato fruits and lettuce leaves after sanitizing by using Artificial Neural Networks. *LWT - Food Science and Technology*, 44, 130 – 138.
- Khadre, M.A., Yousef, A.E. and Kim, J.G. (2001). Microbiological Aspects of Ozone Applications in Food: A review. *Journal of Food Science*, 66, 1242–1252.
- Khan, M.M.T., Pyle, B.H. and Camper, A.K. (2010). Specific and Rapid Enumeration of Viable but Nonculturable and Viable-Culturable Gram-Negative Bacteria by Using Flow Cytometry. *Applied and Environmental Microbiology*, 76, 5088–5096.
- Kieft, I.E., Broers, J.L.V., Caubet-Hilloutou, V., Slaaf, D.W., Ramaekers, F.C.S. and Stoffels, E. (2004). Electric Discharge Plasmas Influence Attachment of Cultured CHO K1 Cells. *Bioelectromagnetics*, 25, 362 – 368.
- Kim, J.E., Lee, D.U. and Min, S.C. (2014). Microbial decontamination of red pepper powder by cold plasma. *Food Microbiology*, 38, 128-136.
- Kim, B., Yun, H., Jung, S., Jung, Y., Jung, H., Choe, W. and Jo, C. (2011). Effect of atmospheric pressure plasma on activation of pathogens inoculated onto bacon using two different gas compositions. *Food microbiology*, 28, 9 – 13.

- Kim, C.H., Bahn, J.H., Lee, S.H., Kim, G.Y., Jun, S.I., Lee, K. and Baek, S.J. (2010). Induction of cell growth arrest by atmospheric non-thermal plasma in colorectal cancer cells. *Journal of Biotechnology*, 150, 530-538.
- Kim, S.H. and Wei, C. (2012). Biofilms. In *Decontamination of Fresh and Minimally Processed Produce*. Ed. Gomez-Lopez, V. M., Wiley-Blackwell Publishing, USA, pp. 59-71.
- Kirezieva, K., Nanyunja, J., Jacxsens, L., van der Vorst, J.G.A.J., Uyttendael, M., Luning, P.A. (2013). Context factors affecting design and operation of Food Safety Management Systems in the fresh produce chain. *Trends in Food Science & Technology*, 32, 108–127.
- Klämpfl, T.G., Isbary, G., Shimizu, T., Li, Y.F., Zimmermann, J.L., Stolz, W., Schlegel, J., Morfill, G.E. and Schmidt, H.U. (2012). Cold Atmospheric Air Plasma Sterilization against Spores and Other Microorganisms of Clinical Interest. *Applied and Environmental Microbiology*, 78, 5077–5082.
- Klockow, P.A. and Keener, K.M. (2009). Safety and quality assessment of packaged spinach treated with a novel ozone-generation system. *LWT - Food Science and Technology*, 42, 1047–1053.
- Koseki, S. and Isobe, S. (2005). Growth of *Listeria monocytogenes* on iceberg lettuce and solid media. *International Journal of Food Microbiology*, 101, 217–225.
- Kostov, K.G., Rocha, V., Koga-Ito, C.Y., Matos, B.M., Algatti, M.A., Honda, R.Y., Kayama, M.E. and Mota, R.P. (2010). Bacterial sterilization by a

- dielectric barrier discharge (DBD) in air. *Surface & Coatings Technology*, 204, 2954–2959.
- Kramer, A., Lademann, J., Bender, C., Sckell, A., Hartmann, B., Münch, S., Hinz, P., Ekkernkamp, A., Matthes, R., Koban, I., Partecke, I., Heidecke, C.D., Masur, K., Reuter, S., Weltmann, K.D., Koch, S. and Assadian, O. (2013). Suitability of tissue tolerable plasmas (TTP) for the management of chronic wounds. *Clinical Plasma Medicine*, 1, 11-18.
- Krol, J.E., Wojtowicz, A.J., Rogers, L.M., Heuer, H., Smalla, K., Krone, S.M. and Top. E.M. (2013). Invasion of *E. coli* biofilms by antibiotic resistance plasmids. *Plasmid*, 70, 110–119.
- Kroupitski, Y., Golberg, d., Belausov, E., Pinto, R., Swartzberg, D., Granot, D. and Sela, S. (2009). Internalization of *Salmonella enterica* in leaves is induced by light and involves chemotaxis and penetration through open stomata. *Applied and Environmental Microbiology*, 75, 6076–6086.
- Kvam, E., Davis, B., Mondello, F. and Garner, A.L. (2012). Nonthermal Atmospheric Plasma Rapidly Disinfects Multidrug- Resistant Microbes by Inducing Cell Surface Damage. *Antimicrobial Agents and Chemotherapy*, 57, 2028–2036.
- Lacombe, A., Niemira, B.A., Gurtler, G.B., Fan, X., Sites, J., Boyd, G. and Chen, H. (2015). Atmospheric cold plasma inactivation of aerobic microorganisms on blueberries and effects on quality attributes. *Food Microbiology*, 46, 479–484.
- Lambert, M.L., Suetens, C., Savey, A., Palomar, M., Hiesmayr, M., Morales, I., Agodi, A., Frank, U., Mertens, K., Schumacher, M. and Wolkewitz, M. (2011).

- Clinical outcomes of health-care-associated infections and antimicrobial resistance in patients admitted to European intensive-care units: a cohort study. *Lancet Infectious Diseases*, 11, 30-38.
- Lambert, P.A. (2002). Mechanisms of antibiotic resistance in *Pseudomonas aeruginosa*. *Journal of the Royal Society of Medicine*, 95, 22 – 26.
- Landini, P. (2009). Cross-talk mechanisms in biofilm formation and responses to environmental and physiological stress in *Escherichia coli*. *Research in Microbiology*, 160, 259-266.
- Laroussi, M. (2009). Low-temperature plasmas for medicine? *Plasma Science, IEEE Transactions on plasma science*, 37, 714-725.
- Laroussi, M. and Leipold, F. (2004). Evaluation of the roles of reactive species, heat, and UV radiation in the inactivation of bacterial cells by air plasmas at atmospheric pressure. *International Journal of Mass Spectrometry* 233, 81 – 86.
- Lau, G.W., Hassett, D.J., Ran, H. and Kong, H. (2004). The role of pyocyanin in *Pseudomonas aeruginosa* infection. *Trends in Molecular Medicine*, 10, 599 – 606.
- Lazar, V. (2011). Quorum sensing in biofilms e How to destroy the bacterial citadels or their cohesion/power? *Anaerobe*, 17, 280-285.
- Le Berre, R., Nguyen, S., Nowak, E., Kipnis, E., Pierre, M., Ader, F., Courcol, R., Guery, B. P., Faure, K. and the Pyopneumagen Group. (2008). Quorum-sensing activity and related virulence factor expression in clinically pathogenic isolates of *Pseudomonas aeruginosa*. *Clinical Microbiology and Infection*, 14, 337 – 343.

- Leduc, M., Guay, D., Coulombe, S. and Leask, R.L. (2010). Effects of non-thermal plasmas on DNA and mammalian cells. *Plasma Processes Polymers*, 7, 899 – 909.
- Lee, H.J., Jung, H., Choe, W., Ham, J.S., Lee, J.H. and Jo, C. (2011). Inactivation of *Listeria monocytogenes* on agar and processed meat surfaces by atmospheric pressure plasma jets. *Food microbiology*, 28, 1468 – 1471.
- Lee, K., Paek, K., Ju, W.T. and Lee, Y. (2006). Sterilization of Bacteria, Yeast, and Bacterial Endospores by Atmospheric-Pressure Cold Plasma using Helium and Oxyge. *The Journal of Microbiology*, 44, 269-275.
- Leff, J.W. and Fierer, N. (2013). Bacterial Communities Associated with the Surfaces of Fresh Fruits and Vegetables. *PLoS ONE*, 8: e59310. doi:10.1371/journal.pone.0059310.
- Lehto, M., Kuisma, R., Määttä, J., Kymäläinenb, H.R. and Mäki, M. (2011). Hygienic level and surface contamination in fresh-cut vegetable production plants. *Food Control*, 22, 469–475.
- Lin, C.M., Moon, S.S., Doyle, M.P. and McWatters, K.H. (2002). Inactivation of *Escherichia coli* O157:H7, *Salmonella enterica* serotype enteritidis, and *Listeria monocytogenes* on lettuce by hydrogen peroxide and lactic acid and by hydrogen peroxide with mild heat. *Journal of Food Protection*, 65, 1215-20.
- Lindsay, D. and von Holy, A. (2006). Bacterial biofilms within the clinical setting: what healthcare professionals should know. *Journal of Hospital Infection*, 64, 313-325.

- Liu, F., Sun, P., Bai, N., Tia, Y., Zhou, H., Wei, S., Zhou, Y., Zhang, J., Zhu, W., Becker, K. and Fang, J. (2010). Inactivation of bacteria in an aqueous environment by a direct-current, cold-atmospheric pressure air plasma microjet. *Plasma Process and Polymers*, 7, 231 – 236.
- Liu, R.H. (2003). Health benefits of fruit and vegetables are from additive and synergistic combinations of phytochemicals. *American Journal for Clinical Nutrition*, 78, 517S–520S.
- Lopez-Galvez, F., Gil, M.I., Truchado, P., Selma, M.V. and Allende, A. (2010). Cross-contamination of fresh-cut lettuce after a short-term exposure during pre-washing cannot be controlled after subsequent washing with chlorine dioxide or sodium hypochlorite. *Food Microbiology*, 27, 199–204.
- Lunov, O., Zablotskii, V., Churpita, O., Chánová, E., Syková, E., Dejneka, A. and Kubinová, S. (2014). Cell death induced by ozone and various non-thermal plasmas: therapeutic perspectives and limitations. *Nature Scientific Reports*, 4, 1 – 11.
- Lushchak, V.I. (2011). Adaptive response to oxidative stress: Bacteria, fungi, plants and animals. *Comparative Biochemistry and Physiology*, 153, 175–190.
- Lynch, M. F., Tauxe, R. V. and Hedberg, C.W. (2009). Review Article. The growing burden of foodborne outbreaks due to contaminated fresh produce: risks and opportunities. *Epidemiological Infections*, 137, 307–315.
- Machala, Z., Janda, M., Hensel, K., Jedlovsky, I., Lestinska, L., Foltin, V., Martisovits, V. and Morvova, M. (2007). Emission spectroscopy of atmospheric

- pressure plasmas for bio-medical and environmental applications. *Journal of Molecular Spectroscopy*, 243, 194-201.
- Mahmoud, B.S.M. (2010). The effects of X-ray radiation on *Escherichia coli* O157:H7, *Listeria monocytogenes*, *Salmonella enterica* and *Shigella flexneri* inoculated on whole Roma tomatoes. *Food Microbiology*, 27, 1057-1063.
- Mahmoud, B.S.M., Bhagat, A.R., and Linton, R.H. (2007). Inactivation kinetics of inoculated *Escherichia coli* O157:H7, *Listeria monocytogenes* and *Salmonella enterica* on strawberries by chlorine dioxide gas. *Food Microbiology*, 24, 736–744.
- Mai-Prochnow, A., Murphy, A.B., McLean, K.M., Kong, M.G. and Ostrikov, K. (2014). Atmospheric pressure plasmas: Infection control and bacterial responses. *International Journal of Antimicrobial Agents*, 43, 508–517.
- Maisch, T., Shimizu, T., Isbary, G., Heinlin, J., Karrer, S., Klämpfl, T.G., Li, Y.F., Morfill, G. and Zimmermann, J.L. (2012). Contact-Free Inactivation of *Candida albicans* Biofilms by Cold Atmospheric Air Plasma. *Applied and Environmental Microbiology*, 78, 4242–4247.
- Majik, M.S., Naik, D., Bhat, C., Tilve, S., Tilvi, S. and D'Souza, L. (2013). Synthesis of (R)-norbgugaine and its potential as quorum sensing inhibitor against *Pseudomonas aeruginosa*. *Bioorganic & Medicinal Chemistry Letters*, 23, 2353–2356.
- Manchali, S., Murthy, K.N.C. and Patil, B.S. (2012). Crucial facts about health benefits of popular cruciferous vegetables. *Journal of functional foods*, 4, 94-106.

- Mani-López, E., García, H.S. and López-Malo, A. (2012). Organic acids as antimicrobials to control *Salmonella* in meat and poultry products. *Food Research International*, 45, 713–72.
- Martinez-Sanchez, A., Tudela, J.A., Luna, C., Allende, A. and Gil, M.I. (2011). Low oxygen levels and light exposure affect quality of fresh-cut Romaine lettuce. *Postharvest Biology and Technology*, 59, 34–42.
- Mattson, T.E., Johny, A.K., Amalaradjou, M.A.R., More, K., Schreiber, D.T., Patel, J., and Venkitanarayanan, K. (2011). Inactivation of *Salmonella* spp. on tomatoes by plant molecules. *International Journal of Food Microbiology*, 144, 464–468.
- McClure, P. (2005). *Escherichia coli*: virulence, stress response and resistance. In understanding pathogen behaviour. Virulence, stress response and resistance. Ed. Griffiths. M. USA: Woodhead Publishing Limited, pp. 240-270.
- Medina-Martinez, M.S. and Santana, M.A. (2012). Quorum sensing. Produce contamination. In Decontamination of Fresh and Minimally Processed Produce. Ed. Gomez-Lopez, V. M. USA: Wiley-Blackwell Publishing, pp. 317-333.
- Mena, K.D. and Gerba, C.P. (2009). Risk Assessment of *Pseudomonas aeruginosa* in Water. In Reviews of Environmental Contamination and Toxicology. Ed. Whitacre, D.M., 201, DOI 10.1007/978-1-4419-0032-6_3.
- Mesaros, N., Nordmann, P., Plesiat, P., Roussel-Delvallez, M., Van Eldere, J., Glupczynski, Y., Van Laethem, Y., Jacobs, F., Lebecque, P., Malfroot, A., Tulkens, P. M. and Van Bambeke, F. (2007). *Pseudomonas aeruginosa*:

- resistance and therapeutic options at the turn of the new millennium. *European Society of Clinical Microbiology and Infectious Diseases, CMI*, 13, 560–578.
- Miller, M.B. and Bassler, B.L. (2001). Quorum sensing in bacteria. *Annual Review Microbiology*, 55, 165–99.
- Misra, N.N., Kaur, S., Tiwari, B.K., Kaur, A., Singh, N. and Cullen, P.J. (2015). Atmospheric pressure cold plasma (ACP) treatment of wheat flour. *Food Hydrocolloids*, 44, 115 – 121.
- Misra, N.N., Patil, S., Moiseev, T., Bourke, P., Mosnier, J.P., Keener, K.M. and Cullen, P.J. (2014). In-package atmospheric pressure cold plasma treatment of strawberries. *Journal of Food Engineering*, 125, 131–138.
- Mittal, R., Aggarwal, S., Sharma, S., Chhibber, S. and Harjai, K. (2009). Urinary tract infections caused by *Pseudomonas aeruginosa*: A minireview. *Journal of Infection and Public Health*, 2, 101-111.
- Mohammed, H.A., Yossef, H.S. and Mohammad, F.I. (2014). The Cytotoxicity Effect of Pyocyanin on Human Hepatocellular Carcinoma Cell Line (HepG2). *Iraqi Journal of Science*, 55, 668 – 674.
- Moiseev, T., Misra, N., Patil, S., Cullen, P., Bourke, P., Keener, K. and Mosnier, J.P. (2014). Post-discharge gas composition of a large-gap DBD in humid air by UV-Vis absorption spectroscopy. *Plasma Sources Science and Technology*, 23, 1-13.
- Montie, T.C., Kelly-Wintenberg, K. and Roth, J.R. (2000). An overview of research using the one atmosphere uniform glow discharge plasma (OAUGDP)

- for sterilisation of surfaces and materials. *IEEE Transactions on plasma science*, 28, 1.
- Montville, T.J., Matthews, K.R. and Kniel, K.E. (2012). Enterohemorrhagic *Escherichia coli*. In *Food Microbiology. An introduction*. Third edition. USA: ASM Press, pp. 170 – 187.
- Moreau, M., Orange, N. and Feuilloley, M. G. J. (2008). Non-thermal plasma technologies: New tools for bio-decontamination. *Biotechnology Advances*, 26, 610 – 617.
- Morent, R. and De Geyter, N. (2011). Inactivation of Bacteria by Non-Thermal Plasmas. *Biomedical Engineering – Frontiers and Challenges*. Available at www.intechopen.com [Accessed on 1 July 2014].
- Moritz, M.M., Flemming, H.C. and Wingender, J. (2010). Integration of *Pseudomonas aeruginosa* and *Legionella pneumophila* in drinking water biofilms grown on domestic plumbing materials. *International Journal of Hygiene and Environmental Health*, 213, 190–197.
- Morris, C., Brody, A.L. and Wicker, L. (2007). Non-Thermal Food Processing/Preservation Technologies: A Review with Packaging Implications. *Packaging Technology Science*, 20, 275–286.
- Mukhopadhyay, S. and Ramaswamy, R. (2012). Application of emerging technologies to control *Salmonella* in foods: A review. *Food Research International*, 45, 666 – 677.
- Nehra, V., Kumar, A. and Dwivedi, H.K. (2008). Atmospheric Non-Thermal Plasma Sources. *International Journal of Engineering*, 2, 53 – 68.

- Niemira, B.A. (2012a). Cold Plasma Decontamination of Foods. *Annual Review of Food Science and Technology*, 3, 125-142.
- Niemira, B.A. (2012b). Cold plasma reduction of *Salmonella* and *Escherichia coli* O157:H7 on almonds using ambient pressure gases. *Journal of Food Science*, 77, 171-175.
- Niemira, B.A. and Sites, J. (2008). Cold plasma inactivates *Salmonella Stanley* and *Escherichia coli* O157:H7 inoculated on golden delicious apples. *Journal of Food Protection*. 71, 1357-1365.
- Noriega, E., Shama, G., Laca, A., Díaz, M. and Kong, M.G. (2011). Cold atmospheric gas plasma disinfection of chicken meat and chicken skin contaminated with *Listeria innocua*. *Food Microbiology*, 7, 1293–1300.
- O’Beirne, D., Gleeson, E., Auty, M. and Jordan, K. (2014). Effects of processing and storage variables on penetration and survival of *Escherichia coli* O157:H7 in fresh-cut packaged carrots. *Food Control*, 40, 71 – 77.
- O’Loughlin, C.T., Miller, L.C., Siryaporn A., Drescher, K., Semmelhack, M.F. and Bassler, B.L. (2013). A quorum-sensing inhibitor blocks *Pseudomonas aeruginosa* virulence and biofilm formation. *Proceedings of the National Academy of Science*, 110, 17981 – 17986.
- Oehmigen, K., Hahnel, M., Branderburg, R., Wilke, Ch., Weltmann, K.D. and Woedtke, T. (2010). The role of acidification for antimicrobial activity of atmospheric pressure plasma in liquids. *Plasma processes and polymers*, 7, 250 – 257.

- Olaimat, A.N. and Holley R.A. (2012). Factors influencing the microbial safety of fresh produce: A review. *Food Microbiology*, 32, 1 – 19.
- Oliver, J.D. (2005). The Viable but Nonculturable State in Bacteria. *The Journal of Microbiology*, 43, 93-100.
- Oliver, J.D. (2010). Recent findings on the viable but nonculturable state in pathogenic bacteria. *FEMS Microbiology Reviews*, 34, 415-425.
- Olmez, H. and Temur, S.D. (2010). Effects of different sanitizing treatments on biofilms and attachment of *Escherichia coli* and *Listeria monocytogenes* on green leaf lettuce. *LWT - Food Science and Technology*, 43, 964–970.
- Olmez, H. (2012). Ozone. Produce contamination. In *Decontamination of Fresh and Minimally Processed Produce*. Ed. Gomez-Lopez, V.M. USA: Wiley-Blackwell Publishing, pp. 177-191.
- Olmez, H. and Kretzschmar, U. (2009). Potential alternative disinfection methods for organic fresh-cut industry for minimizing water consumption and environmental impact. *LWT - Food Science and Technology*, 42, 686–693.
- Pan, J., Sun, K., Liang, Y., Sun, P., Yang, X., Wang, J., Zhang, J., Zhu, W., Fang, J. and Becker, H. (2013). Cold Plasma Therapy of a Tooth Root Canal Infected with *Enterococcus faecalis* Biofilms In Vitro. *Journal of Endodontics*, 39, 105-110.
- Parish, M.E., Beuchat, L.R., Suslow, T.V., Harris, L.J., Garrett, E.H., Farber, J.N., and Busta, F.F. (2003). Methods to Reduce/Eliminate Pathogens from Fresh and Fresh-Cut Produce. *Comprehensive Reviews in Food Science and Food Safety*, 2, 161 – 173.

- Patil, S., Bourke, P., Frias, J.M., Tiwari, B. and Cullen, P.J. (2009). Inactivation of *Escherichia coli* in orange juice using ozone. *Science and Emerging Technologies*, 10, 551 – 557.
- Patil, S., Valdramidis, V.P., Karatzas, K.A.G., Cullen, P.J. and Bourke, P. (2011). Assessing the microbial oxidative stress mechanism of ozone treatment through the responses of *Escherichia coli* mutants. *Journal of Applied Microbiology*, 111, 136 – 144.
- Peeters, E., Nelis, H.J. and Coenye, T. (2008). Comparison of multiple methods for quantification of microbial biofilms grown in microtiter plates. *Journal of Microbiological Methods*, 72, 157–165.
- Pei, X., Lu, X., Liu, J., Liu, D., Yang, Y., Ostrikov, K., Chu, P.K. and Pan, Y. (2012). Inactivation of a 25.5 μm *Enterococcus faecalis* biofilm by a room-temperature, battery-operated, handheld air plasma jet. *Journal of Physics D: Applied Physics*, 45, 1 – 5.
- Peláez, A.M.L., Catañod, C.A.S., Yepesd, E.A.Q., Villarroela, R.R.G., De Antonia, G.L. and Giannuzzi, L. (2012). Inhibitory activity of lactic and acetic acid on *Aspergillus flavus* growth for food preservation. *Food Control*, 24, 177–183.
- Preis, S., Klauson, D. and Gregor, A. (2013). Potential of electric discharge plasma methods in abatement of volatile organic compounds originating from the food industry. *Journal of Environmental Management*, 114, 125–138.
- Priyaja, P., Jayesh, P., Philip, R. and Singh, I.S.B. (2014). Pyocyanin induced in vitro oxidative damage and its toxicity level in human, fish and insect cell lines

for its selective biological applications. *Cytotechnology*, doi: 10.1007/s10616-014-9765-5.

Pui, C.F., Wong, W.C., Chai, L.C., Tunung, R., Jeyaletchumi, P., Noor Hidayah, M.S., Ubong, A., Farinazleen, M.G., Cheah, Y.K. and Son, R. (2011). Review Article *Salmonella*: A foodborne pathogen. *International Food Research Journal*, 18, 465-473.

Rada, R. and Leto, T.L. (2013). Pyocyanin effects on respiratory epithelium: relevance in *Pseudomonas aeruginosa* airway infections. *Trends in Microbiology*, 21, 73 – 81.

Raffellini, S., Guerrero, S. and Alzamora, S.M. (2008). Effect of hydrogen peroxide concentration and pH on inactivation kinetics of *Escherichia coli*. *Journal of Food Safety*, 28, 514–533.

Raffellini, S., Schenk, M., Guerrero, S. and Alzamora, S.M. (2011). Kinetics of *Escherichia coli* inactivation employing hydrogenperoxide at varying temperatures, pH and concentrations. *Food Control*, 22, 920–932.

Ragaert, P., Devlieghere, F. and Debevere, J. (2007). Role of microbiological and physiological spoilage mechanisms during storage of minimally processed vegetables. *Postharvest Biology and Technology*, 44, 185–194.

Ramos, B., Miller, F.A., Brandão, T.R.S., Teixeira, P. and Silva, C.L.M. (2013). Fresh fruits and vegetables—An overview on applied methodologies to improve its quality and safety. *Innovative Food Science and Emerging Technologies*, 20, 1–15.

- Rangel, J.M., Sparling, P.H., Crowe, C., Griffin, P.M. and Swerdlow, D.L. (2005). Epidemiology of *Escherichia coli* O157:H7 Outbreaks, United States, 1982–2002. *Emerging infectious diseases*, 11, 603–609.
- Rasch, M., Andersen, J.B., Nielsen, K.F., Flodgaard, L.R., Christensen, H., Givskov, M. and Gram, L. (2005). Involvement of Bacterial Quorum-Sensing Signals in Spoilage of Bean Sprouts. *Applied and Environmental Microbiology*, 71, 3321–3330.
- Rasmussen, T.B. and Givskov, M. (2006). Quorum-sensing inhibitors as anti-pathogenic drugs. *International Journal of Medical Microbiology*, 296, 149–161.
- Raybaudi-Massilia, R.M., Mosqueda-Melgar, J., Soliva-Fortuny, R. and Martin-Belloso, O. (2009). Control of Pathogenic and Spoilage Microorganisms in Fresh-cut Fruits and Fruit Juices by Traditional and Alternative Natural Antimicrobials. *Comprehensive reviews in food science and food safety*, 8, 157 – 180.
- Reddy, P.M.K., Raju, B.R., Karuppiah, J., Reddy, E.L. and Subrahmanyam, C. (2013). Degradation and mineralization of methylene blue by dielectric barrier discharge non-thermal plasma reactor. *Chemical Engineering Journal*, 217, 41–47.
- Reiss, R., Johnston, J., Tucker, K., DeSesso, J.M. and Keen, C.L. (2012). Estimation of cancer risks and benefits associated with a potential increased consumption of fruits and vegetables. *Food and Chemical Toxicology*, 50, 4421–4427.

- Reszka, K.J., Bilski, P.J. and Britigan, B.E. (2010). Quenching of Singlet Oxygen by Pyocyanin and Related Phenazines. *Photochemistry and Photobiology*, 86, 742 – 746.
- Reszka, K.J., O'Malley, Y., McCormick, M.L., Denning, G.M. and Britigan, B.E. (2004). Oxidation of pyocyanin, a cytotoxic product from *Pseudomonas aeruginosa*, by microperoxidase 11 and hydrogen peroxide. *Free Radical Biology & Medicine*, 36, 1448 – 1459.
- Reszka, K.J., Xiong, Y., Sallans, L., Pasula, R., Olakanmi, O., Hassett, D.J. and Britigan, B.E. (2012). Inactivation of the potent *Pseudomonas aeruginosa* cytotoxin pyocyanin by airway peroxidases and nitrite. *American journal of physiology. Lung cellular and molecular physiology*, 302, L1044–L1056.
- Richard, H.T. and Foster, J.W. (2003). Acid resistance in *Escherichia coli*. *Advanced Applied Microbiology*, 52, 167-186.
- Rod, S. K., Hansen, F., Leipold, F. and Knochel, S. (2012). Cold atmospheric pressure plasma treatment of ready-to-eat meat: inactivation of *Listeria innocua* and changes in product quality. *Food microbiology*, 30, 1-6.
- Rodrigues, A.L., Pereira, M.A., Janknecht, P., Brito, A.G. and Nogueira, R. (2010). Biofilms formed on humic substances: Response to flow conditions and carbon concentrations. *Bioresource Technology*, 101, 6888–6894.
- Roland, U., Holzer, F. and Kopinke F.D. (2002). Improved oxidation of air pollutants in a non-thermal plasma. *Environmental Catalysis*, 73, 315–323.

- Romanova, N.A., Gawande, P.V., Brovko, L.Y and Griffiths, M.W. (2007). Rapid methods to assess sanitizing efficacy of benzalkonium chloride to *Listeria monocytogenes* biofilms. *Journal of Microbiological Methods*, 71, 231–237.
- Rowan, N.J. (2004). Viable but non culturable forms of food and waterborne bacteria: Quo Vadis? *Trends in Food Science & Technology*, 15, 462–467.
- Rowan, N.J., Espie, S., Harrower, J., Anderson, J.G., Marsili, L. and MacGregor, S.J. (2007). Pulsed-Plasma Gas-Discharge Inactivation of Microbial Pathogens in Chilled Poultry Wash Water. *Journal of Food Protection*, 70, 2805-2810.
- Rutherford, S.T. and Bassler, B.L. (2012). Bacterial Quorum Sensing: Its Role in Virulence and Possibilities for Its Control. *Cold Spring Harbor Perspectives in Medicine*, 2(11), a012427. doi:10.1101/cshperspect.a012427.
- Sagonga, H.G., Lee, S.Y., Changa, P.S., Heud, S., Ryub, S., Choia, Y.J, Kang, D.H. (2011). Combined effect of ultrasound and organic acids to reduce *Escherichia coli* O157:H7, *Salmonella* Typhimurium, and *Listeria monocytogenes* on organic fresh lettuce. *International Journal of Food Microbiology*, 145, 287–292.
- São José, J.F.B., Andrade, N.J., Ramos, A.M., Vanetti, M.C.D., Stringheta, P.C. and Chaves, J.B.P. (2014). Decontamination by ultrasound application in fresh fruits and vegetables. *Food Control*, 45, 36 – 50.
- Scheetz, M.H., Hoffman, M., Bolon, M.K., Schulert, G., Estrellado, W., Baraboutis, I.G., Sriram, P., Dinh, M., Owens, L.K. and Hauser, A.R. (2009). Morbidity associated with *Pseudomonas aeruginosa* bloodstream infections. *Diagnostic microbiology and infectious disease*, 64, 311-319.

- Scholtz, V., Pazlarová, J., Soušková, N., Khun, J. and Julák, J. (2015). Nonthermal plasma — A tool for decontamination and disinfection. *Biotechnology Advances*, doi:10.1016/j.biotechadv.2015.01.002.
- Schuster, M. and Greenberg, E.P. (2006). A network of networks: Quorum-sensing gene regulation in *Pseudomonas aeruginosa*. *International Journal of Medical Microbiology*, 296, 73–81.
- Schwaiger, K., Helmke, K., Hölzel, C.S. and Bauer, J. (2011). Antibiotic resistance in bacteria isolated from vegetables with regards to the marketing stage (farm vs. supermarket). *International Journal of Food Microbiology*, 148, 191–196.
- Seo, K.H. and Frank, J.F. (1999). Attachment of *Escherichia coli* O157:H7 to Lettuce Leaf Surface and Bacterial Viability in Response to Chlorine Treatment as Demonstrated by Using Confocal Scanning Laser Microscopy. *Journal of Food Protection*, 62, 3-9.
- Sharma, G., Rao, S., Bansal, A., Dang, S., Gupta, S. and Gabrani, R. (2014). *Pseudomonas aeruginosa* biofilm: Potential therapeutic targets. *Biologicals*, 42, 1-7.
- Sheldon, J.R., Yim, M.S. and Leung, K.T. (2012). Role of rpoS in *Escherichia coli* O157:H7 Strain H32 Biofilm Development and Survival. *Applied and Environmental Microbiology*, 78, 8331–8339.
- Shen, C., Luo, Y., Nou, X., Bauchan, G., Zhou, B., Wang, Q. and Millner, P. (2012). Enhanced inactivation of *Salmonella* and *Pseudomonas* biofilms on stainless steel by use of T-128, a fresh-produce washing aid, in chlorinated wash solutions. *Applied and Environmental Microbiology*, 78, 6789–6798.

- Shen, Y., Stojicic, S. and Haapasalo, M. (2011). Antimicrobial Efficacy of Chlorhexidine against Bacteria in Biofilms at Different Stages of Development. *Journal of Endodontics*, 37, 657–661.
- Sheng, G.P., Yu, H.Q. and Li, X.Y. (2010). Extracellular polymeric substances (EPS) of microbial aggregates in biological wastewater treatment systems: A review. *Biotechnology Advances*, 28, 882–894.
- Shi, X. and Zhu, X. (2009). Biofilm formation and food safety in food industries. *Trends in Food Science & Technology*, 20, 407–413.
- Shi, X., Wu, Z., Namvar, A., Kostrzynska, M., Dunfield, K. and Warriner, K. (2009). Microbial population profiles of the microflora associated with pre- and postharvest tomatoes contaminated with *Salmonella* Typhimurium or *Salmonella* Montevideo. *Journal of Applied Microbiology*, 107, 329–338.
- Shintani, H., Sakudo, A., Burke, P. and McDonnell, G. (2010). Gas plasma sterilization of microorganisms and mechanisms of action (Review). *Experimental and Therapeutic Medicine*, 1, 731-738.
- Siddiqui, M.W., Chakraborty, I., Ayala-Zavala, J.F. and Dhua, R.S. (2011). Advances in minimal processing of fruits and vegetables: A review. *Journal of scientific and Industrial research*, 70, 823 – 834.
- Smith, R.S. and Iglewski, B.H. (2003). *P. aeruginosa* quorum-sensing systems and virulence. *Current Opinion in Microbiology*, 6, 56 – 60.
- Solomon, E.B. and Sharma, M. (2009). Microbial attachment and limitations of decontamination methodologies. In: The produce contamination problem:

- Causes and solutions. Ed. Sapers, G.M., Solomon, E.B., Matthews, K.R., Elsevier Inc., USA, pp. 21 – 45.
- Song, H.P., Kim, B., Choe, J.H., Jung, S., Moon, S.S., Choe, W. and Jo, C. (2009). Evaluation of atmospheric pressure plasma to improve the safety of sliced cheese and ham inoculated by 3-strain cocktail *Listeria monocytogenes*. *Food Microbiology*, 26, 432-436.
- Spadaro, D. and Gullino, M.L. (2004). State of the art and future prospects of the biological control of postharvest fruit diseases. *International Journal of Food Microbiology*, 91, 185–194.
- Spector, M.P. and Kenyon, W.J. (2012). Resistance and survival strategies of *Salmonella enterica* to environmental stresses. *Food Research International*, 45, 455–481.
- Srey, S., Jahid, I.K. and Ha, S.D. (2014a). Biofilm formation in food industries: A food safety concern. *Food Control*, 31, 572 – 585.
- Srey, S., Park, S.Y., Jahid, I.K. and Ha, S.D. (2014b). Reduction effect of the selected chemical and physical treatments to reduce *L. monocytogenes* biofilms formed on lettuce and cabbage. *Food Research International*, 62, 484-491.
- Stepanovic, S., Vukovic, D., Dakić, I., Savić, B and Švabić-Vlahović, M. (2000). A modified microtiter-plate test for quantification of staphylococcal biofilm formation. *Journal of Microbiological Methods*, 40, 175–179.
- Stewart, P.S. and Costerton, J.W. (2001). Antibiotic resistance of bacteria in biofilms. *The Lancet*, 358, 135–138.

- Stoffels, E., Sakiyama, Y. and Graves, D.B. (2008). Cold atmospheric plasma: charged species and their interactions with cells and tissues. *IEEE Transactions on plasma science*, 36, 1441 – 1457.
- Stoodley, P., Sauer, K., Davies, D. G. and Costerton, J. W. (2002). Biofilms as complex differentiated communities. *Annual Review of Microbiology*, 56, 187 – 209.
- Suhem, K., Matan, N., Nisoa, M. and Matan, N. (2013). Inhibition of *Aspergillus flavus* on agar media and brown rice cereal bars using cold atmospheric plasma treatment. *International Journal of Food Microbiology*, 161, 107–111.
- Sun, Y., Yu, S., Sun, P., Wu, H., Zhu, W., Liu, W., Zhang, J., Fang, J. and Li, R. (2012). Inactivation of *Candida* biofilms by non-thermal plasma and its enhancement for fungistatic effect of antifungal drugs. *PLoS ONE* 7(7): e40629. doi:10.1371/journal.pone.004062
- Sureshkumar, A., Sankar, R., Mandal, M. and Neogi, S. (2010). Effective bacterial inactivation using low temperature radio frequency plasma. *International Journal of Pharmaceutics*, 396, 17–22.
- Sydnor, E.R.M. and Perl, T.M. (2011). Hospital Epidemiology and Infection Control in Acute-Care Settings. *Clinical Microbiology Reviews*, 24, 141-173.
- Takeuchi, K., Hassan, A.N. and Frank, J.F. (2001). Penetration of *Escherichia coli* O157:H7 into lettuce as influenced by modified atmosphere and packaging. *Journal of Food Protection*, 11, 1820-1824.

- Tang, Y.Z., Lu, X.P., Laroussi, M. and Dobbs, F.C. (2008). Sublethal and killing effects of atmospheric-pressure, non-thermal plasma on eukaryotic microalgae in aqueous media. *Plasma process and polymers*, 5, 552 – 558.
- Tendero, C., Tixier, C., Tristant, P., Desmaison, J. and Leprince P. (2006). Atmospheric pressure plasmas: A review. *Spectrochimica Acta*, 61, 2 – 30.
- Teschler, J.K., Zamorano-Sánchez, D., Utada, A.S., Warner, C.J.A., Wong, G.C.L., Lington, R.G., and Yildiz, F.H. (2015). Living in the matrix: assembly and control of *Vibrio cholerae* biofilms. *Nature Reviews. Microbiology*, 13, 255 – 268.
- Thanomsub, B., Anupunpisit, V., Chanphetch, S., Watcharachaipong, T., Poonkhum, R. and Srisukont, C. (2002). Effects of ozone treatment on cell growth and ultrastructural changes in bacteria. *Journal of General Applied Microbiology*, 48, 193-199.
- Torlak, E., Sert, D. and Ulca, P. (2013). Efficacy of gaseous ozone against *Salmonella* and microbial population on dried oregano. *International Journal of Food Microbiology*, 165, 276–280.
- Traba, C. and Liang, J.F. (2011). Susceptibility of *Staphylococcus aureus* biofilms to reactive discharge gases. *Biofouling*, 27, 763–772.
- Traba, C., Chen, L. and Liang, J.F. (2013). Low power gas discharge plasma mediated inactivation and removal of biofilms formed on biomaterials. *Current Applied Physics*, 13, S12–S18.

- Tredget, E.E., Shankowsky, H.A., Rennie, R., Burrell, R.E. and Logsetty, S. (2004). *Pseudomonas* infections in the thermally injured patient. Review. *Burns*, 30, 3-26.
- Uhm, H.S. and Hong, Y.C. (2011). Various microplasma jets and their sterilization of microbes. *Thin Solid Films*, 519, 6974–6980.
- Ulbin-Figlewicz, N, Jarmoluk, A. and Marycz, K. (2014). Antimicrobial activity of low-pressure plasma treatment against selected foodborne bacteria and meat microbiota. *Annals of Microbiology*, doi: 10.1007/s13213-014-0992-y.
- Urashima, K. and Chang, J.S. (2000). Removal of Volatile Organic Compounds from Air Streams and Industrial Flue Gases by Non-Thermal Plasma Technology. *IEEE Transactionson Dielectrics and Electrical Insulation*, 7, 602 – 614.
- Van Boxstael, S., Habib, I., Jacxsens, L., De Vocht, M., Baert, L., Van De Perre, E., Rajkovic, A., Lopez-Galvez, F., Sampers, I., Spanoghe, P., De Meulenaer, B and Uyttendaele, M. (2013). Food safety issues in fresh produce: Bacterial pathogens, viruses and pesticide residues indicated as major concerns by stakeholders in the fresh produce chain. *Food Control*, 32, 190-197.
- Van Breda, S.G.J., Theo de Kok, M.C.M. and Van Delft, J.H.M. (2008). Mechanisms of colorectal and lung cancer prevention by vegetables: a genomic approach. *Journal of Nutritional Biochemistry*, 19, 139–157.
- Van Delden, C. and Iglewski, B.H. (1998). Cell-to-Cell Signaling and *Pseudomonas aeruginosa* Infections. *Emerging Infectious Diseases*, 4, 551 – 560.

- Van Duyn, M.A. and Pivonka, E. (2000). Overview of the health benefits of fruit and vegetable consumption for dietetic professional: Selected literature. *Journal of the American Dietetic Association*, 100, 1511–1521.
- Vandenbroucke, A.M., Morent, R., De Geyter, N. and Leys, C. (2011). Non-thermal plasmas for non-catalytic and catalytic VOC abatement. *Journal of Hazardous Materials*, 195, 30–54.
- Vandeputte, O.M., Kiendrebeogo, M., Rasamiravaka, T., Ste´vigny, V., Duez, P., Rajaonson, S., Diallo, B., Mol, A., Baucher, M. and El Jaziri, M. (2011). The flavanone naringenin reduces the production of quorum sensing-controlled virulence factors in *Pseudomonas aeruginosa* PAO1. *Microbiology*, 157, 2120 – 2132.
- Vandervoort, K.G. and Brelles-Marino, G. (2014). Plasma-Mediated Inactivation of *Pseudomonas aeruginosa* Biofilms Grown on Borosilicate Surfaces under Continuous Culture System. *PLoS One*, 9, e108512.
- Venier, A.-G., Leroyer, C., Slekovec, C., Talon, D., Bertrand, X., Parer, S., Alfandari, S., Guerin, J.M., Megarbane, B., Lawrence, C., Clair, B., Lepape, A., Perraud, M., Cassier, P., Trivier, D., Boyer, A., Dubois, V., Asselineau, J., Rogues, A.M. and Thiébaud, R. (2014). Risk factors for *Pseudomonas aeruginosa* acquisition in intensive care units: a prospective multicentre study. *Journal of Hospital Infection*, 88, 103-108.
- Von Woedtke, T., Reuter, S., Masur, K. and Weltmann, K.D. (2013). Plasmas for medicine. *Physics Reports*, 530, 291-320.

- Vu, B., Chen, M., Crawford, R.J. and Ivanova, E.P. (2009). Bacterial Extracellular Polysaccharides Involved in Biofilm Formation. *Molecules*, 14, 2535-2554.
- Vlamakis, H., Chai, Y., Beaugerard, P., Losick, R. and Kolter, R. (2013). Sticking together: building a biofilm the *Bacillus subtilis* way. *Nature Reviews Microbiology*, 11, 157-168.
- Wan, J., Coventry, J., Swiergon, P., Sanguansri, P. and Versteeg, C. (2009). Advances in innovative processing technologies for microbial inactivation and enhancement of food safety e pulsed electric field and low-temperature plasma. *Trends in Food Science & Technology*, 20, 414-424.
- Wang, H., Zhou, B. and Feng, H. (2012). Surface characteristics of fresh produce and their impact on attachment and removal of human pathogens. Produce contamination. In Decontamination of Fresh and Minimally Processed Produce. Ed. Gomez-Lopez, V. M. USA: Wiley-Blackwell Publishing, pp. 43-55.
- Wang, S., Melnyk, J.P., Tsao, R. and Marcone. M.F. (2010). How natural dietary antioxidants in fruits, vegetables and legumes promote vascular health. *Food Research International*, 44, 14–22.
- Warnecke, T. and Gill, R.T. (2005). Organic acid toxicity, tolerance, and production in *Escherichia coli* biorefining applications. *Microbial Cell Factories*, 4, 25. doi:10.1186/1475-2859-4-25.
- Warning, A. and Datta, A.K. (2013). Interdisciplinary engineering approaches to study how pathogenic bacteria interact with fresh produce. *Journal of Food Engineering*, 114, 426–448.

- Wei, Q. and Ma, L.Z. (2013). Biofilm Matrix and Its Regulation in *Pseudomonas aeruginosa*. *International Journal of Molecular Science*, 14, 20983-21005.
- Weingrow, D. (2012). Update on Emerging Infections: News From the Centers for Disease Control and Prevention. *Infectious disease/CDC update*, 60, 374-376.
- Wende, K., Straßenburg, S., Haertel, B., Harms, M., Holtz, S., Barton, A., Masur, K., von Woedtke, T. and Lindequist, U. (2014). Atmospheric pressure plasma jet treatment evokes transient oxidative stress in HaCaT keratinocytes and influences cell physiology. *Cell Biology International*, 38, 412 – 425.
- Wong, Y.C., Senan, M.S.R. and Atiqah, N.A. (2013). Removal of Methylene Blue and Malachite Green Dye Using Different Form of Coconut Fibre as Absorbent. *Journal of Basic & Applied Sciences*, 9, 172-177.
- Wootton-Beard, P.C. and Ryan, L. (2011). Improving public health?: The role of antioxidant-rich fruit and vegetable beverages. *Food Research International*, 44, 3135–3148.
- Wu, A.S., Kalghatgi, S., Dobrynin, D., Sensenig, R., Cerchar, E., Podolsky, E., Dulaimi, E., Paff, M., Wasko, K., Arjunan, K.P., Garcia, K., Fridman, G., Balasubramanian, M., Ownbey, R., Barbee, K.A., Fridman, A., Friedman, G., Joshi, S.G. and Brooks, A.D. (2013). Porcine intact and wounded skin responses to atmospheric nonthermal plasma. *Journal of Surgical Research*, 179, 1 – 12.
- Xu, H.S., Roberts, N., Singleton, F.L., Attwell, R.W., Grimes, D.J. and Colwell, R.R. (1982). Survival and Viability of Nonculturable *Escherichia coli* and *Vibrio cholerae* in the Estuarine and Marine Environment. *Microbial Ecology. Pathogens*, 8, 313-323.

- Yang, B., Chen, J., Yu, Q., Lin, M., Azlin, M. and Chen, M. (2010). Inactivation of Bacillus Spores Using a Low-Temperature Atmospheric Plasma Brush. *IEEE Transactions on plasma science*, 38, 1624-1631.
- Yang, L., Liu, Y., Wu, H., Høiby, N., Molin, S. and Song, Z. (2011). Current understanding of multi-species biofilms. Review. *International Journal of Oral Science*, 3, 74-81.
- Yu, H., He, X., Xie, W., Xiong, J., Sheng, H., Guo, S., Huang, C., Zhang, D. and Zhang, K. (2014). Elastase LasB of *Pseudomonas aeruginosa* promotes biofilm formation partly through rhamnolipid-mediated regulation. *Canadian Journal of Microbiology*, 60, 227 – 235.
- Yu, H., Perni, S., Shi, J. J., Wang, D. Z., Kong, M. G. and Shama, G. (2006). Effects of cell surface loading and phase of growth in cold atmospheric gas plasma inactivation of *Escherichia coli* K12. *Journal of Applied Microbiology*, 101, 1323 – 1330.
- Yun, H., Kim, B., Jung, S., Kruk, Z. A., Kim, D. B., Choe, W. and Jo, C. (2010). Inactivation of *Listeria monocytogenes* inoculated on disposable plastic tray, aluminium foil, and paper cup by atmospheric pressure plasma. *Food control*, 21, 1182 – 1186.
- Zelaya, A.J., Stough, G., Rad, N., Vandervoort, K. and Brelles-Marino, G. (2010). *Pseudomonas aeruginosa* Biofilm Inactivation: Decreased Cell Culturability, Adhesiveness to Surfaces, and Biofilm Thickness Upon High-Pressure Nonthermal Plasma Treatment. *IEEE Transactions on Plasma Science, IEEE Nuclear and Plasma Sciences Society*, 38, 3398-3403.

- Zhang, M., Oh, J.K., Cisneros-Zevallos, L. and Akbulut, M. (2013). Bactericidal effects of nonthermal low-pressure oxygen plasma on *S. typhimurium* LT2 attached to fresh produce surfaces. *Journal of Food Engineering*, 119, 425–432.
- Zhang, J., Lee, K.H., Cui, L. and Jeong, T. (2009). Degradation of methylene blue in aqueous solution by ozone-based processes. *Journal of Industrial and Engineering Chemistry*, 15, 185-189.
- Zheng, L., Bae, Y.M., Jung, K.S., Heu, S. and Lee, S.Y. (2013). Antimicrobial activity of natural antimicrobial substances against spoilage bacteria isolated from fresh produce. *Food Control*, 32, 665–672.
- Ziuzina, D., Patil, S., Cullen, P.J., Boehm, D. and Bourke, P. (2014). Dielectric Barrier Discharge Atmospheric Cold Plasma for Inactivation of *Pseudomonas aeruginosa* Biofilms. *Plasma Medicine*, 4, 137 – 152.
- Ziuzina, D., Patil, S., Cullen, P.J., Keener, K.M. and Bourke, P. (2013). Atmospheric cold plasma inactivation of *Escherichia coli* in liquid media inside a sealed package. *Journal of applied microbiology*, 114, 778-787.
- Ziuzina, D., Patil, S., Cullen, P.J., Keener, K.M. and Bourke, P. (2014). Atmospheric cold plasma inactivation of *Escherichia coli*, *Salmonella enterica* serovar Typhimurium and *Listeria monocytogenes* inoculated on fresh produce. *Food Microbiology*, 42, 109–116.

Peer reviewed publications

1. Ziuzina, D., Boehm, D., Patil, S., Cullen, P.J., Bourke, P. Cold plasma inactivation of bacterial biofilms and reduction of quorum sensing regulated virulence factors. *PLoS ONE* 10(9): e0138209. doi:10.1371/journal.pone.0138209.
2. Ziuzina, D., Han, L., Cullen, P.J., Bourke, P. (2015). Cold plasma inactivation of internalised bacteria and biofilms for *Salmonella enterica* serovar Typhimurium, *Listeria monocytogenes* and *Escherichia coli*. *International Journal of Food Microbiology*, 210, 53-61.
3. Ziuzina, D., Patil, S., Cullen, P.J., Boehm, D., Bourke, P. (2014). Dielectric barrier discharge atmospheric cold plasma for inactivation of *Pseudomonas aeruginosa* biofilms. *Plasma Medicine*, 4, 89 – 104.
4. Ziuzina, D., Patil, S., Cullen, P.J., Keener, K.M., Bourke, P. (2014). Atmospheric Cold Plasma inactivation of *Escherichia coli*, *Salmonella enterica* serovar Typhimurium and *Listeria monocytogenes* inoculated on fresh produce. *Food Microbiology*, 42, 109–116.
5. Ziuzina, D., Patil, S., Cullen, P.J., Bourke P. (2014). Atmospheric cold plasma: promising tool for inactivation of biofilms. In: Industrial, medical and environmental applications of microorganisms: current status and trends. ISBN Print version: 978-90-8686-243-6 ISBN E-

book: 978-90-8686-795-0 Edited by: A. Méndez-Vilas. Published by: Wageningen Academic Publishers. Peer reviewed Book Chapter.

6. Misra, N.N., Ziuzina, D., Cullen, P.J., Keener, K.M. (2013). Characterisation of a novel Atmospheric Air Cold Plasma System for treatment of packaged biomaterials. *Transactions of the ASABE*, 56, 1011 – 1016.
7. Ziuzina, D., Patil, S., Cullen, P.J., Keener, K.M., Bourke, P. (2012). Atmospheric cold plasma inactivation of *Escherichia coli* in liquid media inside a sealed package. *Journal of Applied Microbiology*, 114, 778 – 787.

Congress and conferences

1. In-Package Non-Thermal Plasma: A New Paradigm in Food Science. P.J. Cullen, N.N. Misra, Dana Ziuzina, Daniela Boehm, Paula Bourke, Vladimir Milosavljevic, Kevin Keener. The 7th International Symposium on Advanced Plasma Science and Its Applications for Nitrides and Nanomaterials / 8th International Conference on Plasma Nanotechnology and Science, 26-31 March 2015, Nagoya, Japan.
2. In-package dielectric barrier discharge atmospheric cold plasma (DBD ACP) for inactivation of *Pseudomonas aeruginosa* biofilms. D. Ziuzina, S. Patil, P.J. Cullen, D. Boehm, P. Bourke. The 5th

International Conference on Plasma Medicine, 18-23 May 2014, Nara, Japan.

3. Effect of different storage conditions on decontamination efficacy of high voltage atmospheric cold plasma against *E. coli* in model media, internalised and bacterial biofilms formed on lettuce. D. Ziuzina, L. Han, P.J. Cullen, P. Bourke. Safefood Knowledge Networks Conference, 21 October 2014, Dublin, Ireland.
4. Effect of in-package high voltage Ireland, atmospheric cold plasma on *L. monocytogenes* in model media, internalised and bacterial biofilms formed on lettuce at different storage conditions. D. Ziuzina, L. Han, P.J. Cullen, P. Bourke. Oral presentation at Safefood Knowledge NetworkConference. 16 September 2014, Ireland,
5. Atmospheric cold plasma: Promising tool for biofilm removal Ziuzina D., Patil S., Cullen P.J., and Bourke P. The V International Conference on Environmental, Industrial and Applied Microbiology (BioMicroWorld2013), 2-4 October, 2013, Madrid, Spain.
6. Dielectric Barrier Discharge Atmospheric Cold Plasma for inactivation of Bacterial biofilms. Ziuzina, D., Patil, S., Cullen, P.J., Bourke P. Third European Congress on Microbial Biofilms (EUROBIOFIMS2013), 9 – 11 September 2013, Ghent, Belgium.

7. In-package inactivation of E. coli in liquid media by non-thermal atmospheric pressure plasma. Ziuzina, D., Patil, S., Cullen, P.J., Bourke P. Oral presentation at Safe Food Knowledge Networks Conference, 2 – 3 May 2012. Belfast, UK.

Awards

2014 ASABE Rain Bird Engineering Concept of the Year Award

K. Keener, NN Misra, D. Ziuzina, PJ. Cullen

2015 SfAM image competition winner (1st Place)

P. Bourke, D. Ziuzina

“What Lurks Beneath.....”

