

---

Doctoral

Science

---

2019-1

## Atmospheric Cold Plasma Interactions With Microbiological Risks In Fresh Food Processing

Apurva Patange

Technological University Dublin, [apurva.patange@tudublin.ie](mailto:apurva.patange@tudublin.ie)

Follow this and additional works at: <https://arrow.tudublin.ie/sciendoc>



Part of the [Food Biotechnology Commons](#), and the [Food Processing Commons](#)

---

### Recommended Citation

Patange, A. (2019) *Atmospheric Cold Plasma Interactions With Microbiological Risks In Fresh Food Processing*. Doctoral thesis, DIT, 2019. doi.org/10.21427/f46k-6k27

This Theses, Ph.D is brought to you for free and open access by the Science at ARROW@TU Dublin. It has been accepted for inclusion in Doctoral by an authorized administrator of ARROW@TU Dublin. For more information, please contact [yvonne.desmond@tudublin.ie](mailto:yvonne.desmond@tudublin.ie), [arrow.admin@tudublin.ie](mailto:arrow.admin@tudublin.ie), [brian.widdis@tudublin.ie](mailto:brian.widdis@tudublin.ie).



This work is licensed under a [Creative Commons Attribution-NonCommercial-Share Alike 3.0 License](#)

**ATMOSPHERIC COLD PLASMA INTERACTIONS  
WITH MICROBIOLOGICAL RISKS IN FRESH FOOD  
PROCESSING**

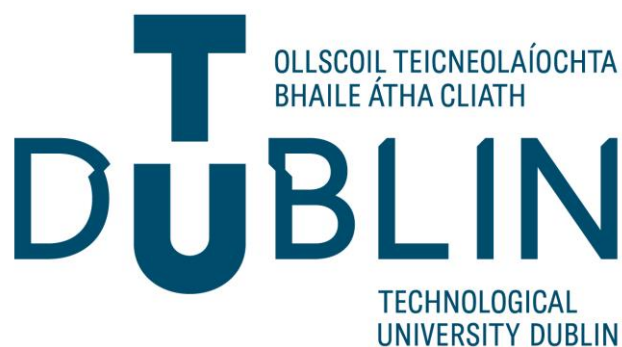

**Apurva Patange**

Thesis submitted to Technological University Dublin, in accordance with the  
requirements for the degree of  
**DOCTOR OF PHILOSOPHY**

Supervisors:

Prof. Paula Bourke,

Prof. P. J. Cullen

**Technological University Dublin**

**School of Food Science and Environmental Health**

**January 2019**

## Abstract

Atmospheric cold plasma (ACP) is a novel emerging non-thermal technology that has attracted attention as a decontamination tool in several industrial, food and healthcare sectors. This study investigated the anti-microbial efficacy of ACP against microbiological risks associated with fresh foods. Treatment was performed using in-package ‘dry’ ACP technology and plasma functionalised liquid to decontaminate microorganisms, exploring the responses to real and challenging microbiological risks pertinent to both fresh foods themselves as well as the effluents generated from food processing industry. A range of critical control process parameters were investigated with respect to key pathogenic and spoilage microorganisms commonly implicated in the food environment.

The inactivation efficacy of ACP against all applied bacterial strains was depended on applied voltage, treatment time and post treatment storage time (PTST). Greater inactivation was obtained at 80 kV with 24 h of PTST providing greater interaction between the bacteria and the reactive species. Bacterial biofilms were significantly susceptible to ACP. Viable and metabolic active cells in mono and dual biofilms were inactivated within short treatment time. Different inactivation rate was observed, depending on physiological state of the bacteria (planktonic or biofilms, mono or mixed culture). An extended time was required to reduce the challenge mixed culture biofilm formed on lettuce at environmental stress conditions. The study demonstrated that produce storage conditions, such as temperature and storage time had interactive effects on bacterial proliferation, stress response and susceptibility to the ACP treatment, highlighting the importance of preventive measures as key factors for the assurance of microbiological safety of fresh produce. Further, to ascertain the effect of stress conditions on ACP’s bacterial inactivation efficacy, *L. monocytogenes* and its knockout mutants associated with stress were treated with sub-lethal stress conditions. The gene expression of stress associated genes were significantly increased after 1 min treatment, while long treatment time reduced the gene expression and some cases down-regulated *prfA* and *gadD3* gene expression. By comparing the response of mutants under ACP exposure to key processing parameters, the experimental results presented here provide a baseline for understanding the bacterial genetic response and resistance to plasma stress and offers promising insights for optimizing ACP applications.

The impact of the ACP technology on model food surface and wash-water generated from fresh produce processing was also investigated. The ACP treatment reduced microbial load showing similar efficacy as chlorine, providing further advantage of continuously treating the

lettuce wash water. Micro-bubbling along with agitation assisted bacterial detachment and distribution of reactive species, thus increasing bacterial inactivation efficacy from fresh produce and wash water. Liquid media complexity was explored as a factor in cold plasma decontamination efficacy for microbiologically safe effluents from food processing. The high nutritive components in the model effluents exerted a protective effect during treatment, showing higher inactivation in phosphate buffer solution (PBS) than in nutrient rich wastewater effluents. ACP was effective to inactivate principle indicator bacteria (mono and mixed culture planktonic bacteria and spores) from model dairy and meat wastewaters. This study also investigated the eco-toxicological impact of cold plasma treatment of the model wastewater using a range of aquatic bioassays. Differing sensitivities were observed to ACP treated effluents across the different test bio-assays; with greater sensitivity retained to plasma treated meat effluent than dairy effluent. The toxic effects were dependent on concentration and treatment time of the ACP treated effluents.

ACP shows potential as an efficient decontamination approach against bacteria in their most resistant, biofilm or spore form associated with complex and nutritious food products during food production to wastewaters generated by the food industries.

## **Declaration**

I certify that this thesis which I now submit for examination for the award of Doctor of Philosophy, is entirely my own work and has not been taken from the work of others, save to the extent that such work has been cited and acknowledged within the text of my work.

This thesis was prepared according to the regulations for postgraduate study by research of Technological University Dublin and has not been submitted in whole or in part for another award in any other third level institution.

The work reported on in this thesis conforms to the principles and requirements of Technological University Dublin's guidelines for ethics in research.

TU Dublin has permission to keep, lend or copy this thesis in whole or in part, on condition that any such use of the material or the thesis is duly acknowledged.

Apurva Patange

Date:

## **Acknowledgement**

I wish to express my gratitude to my supervisors Prof. Paula Bourke and Prof. P. J. Cullen, for offering me the opportunity to join their research group and for their tremendous amount of valuable guidance, expertise and encouragement throughout my PhD research. I would like to extend my sincere thanks to Dr. Daniela Boehm, who kindly shared her knowledge and experience with me and provided valuable suggestions and encouragement during my research.

I would like to thank whole BioPlasma research group, all academic and technical staff in TU Dublin in school of Food science and Environmental health and TU Dublin FOCAS Institute for all assistance and help. I am very grateful to Dr. Peng Lu for his contribution and help for the system design and set up as well as diagnostics of submerged atmospheric cold plasma system. Many thanks to all my dear colleagues and friends in TU Dublin for such a friendly, supportive and efficient working environment.

I would like to acknowledge the financial support from following funding sources; Food Institutional Research Measure (FIRM) administered by Department of Agriculture, Food and the Marine, Ireland (DAFM 13/F/442) and (DAFM 13/F/444).

I wish to convey thanks to all my friends for their constant support and friendship who always gave a smile during my periods of highs and lows. Finally, a very special thanks to my family for their continuous love, encouragement and support during this research. All this would not have been possible without their support and inspiration.

## Table of Contents

<b>Abstract</b> .....	<b>ii</b>
<b>Declaration</b> .....	<b>iv</b>
<b>Acknowledgement</b> .....	<b>v</b>
<b>Table of Contents</b> .....	<b>vi</b>
<b>List of Figures</b> .....	<b>ix</b>
<b>List of Tables</b> .....	<b>xiv</b>
<b>List of Abbreviations</b> .....	<b>xvi</b>
<b>Chapter 1 Introduction</b> .....	<b>1</b>
1.1 Microbiological challenges associated with fresh-cut and minimally processed produce .....	1
1.2 Microbiological concern associated to food industry wastewater treatment .....	10
1.3 Microbial resistance .....	18
1.4 Current Decontamination technologies.....	33
1.5 Atmospheric cold plasma (ACP) .....	39
1.6 Application of Atmospheric cold plasma .....	46
1.7 Research Aim and objectives.....	53
<b>Chapter 2 Methods and Materials</b> .....	<b>55</b>
2.1 Microbial strains and growth conditions.....	55
2.2 Cell culture.....	57
2.3 Liquid media under investigation .....	58
2.4 Bacterial Biofilm formation on abiotic surfaces.....	61
2.5 Preparation of meat samples .....	62
2.6 Preparation of produce.....	63
2.7 Stress studies.....	64
2.8 Experimental design.....	64
2.9 Post treatment analysis.....	71
2.10 Statistical analysis.....	78
<b>Chapter 3 Controlling <i>Brochothrix thermosphacta</i> as a spoilage risk using in-package ACP</b> .....	<b>80</b>
3.1 Effect of the plasma treatment time and post storage time on ACP inactivation efficiency against planktonic cells of <i>B. thermosphacta</i> .....	80
3.2 The effect of nutritive environments on inactivation of <i>B. thermosphacta</i> .....	83
3.3 Adhesion and biofilm formation capacity of <i>B. thermosphacta</i> .....	84

3.4 Effect of ACP treatment on <i>B. thermosphacta</i> biofilms .....	86
3.5 In-package ACP treatment of lamb chop .....	88
3.6 Discussion .....	92
3.7 Conclusions .....	94
<b>Chapter 4 Potential of atmospheric cold plasma treatment for control of bacterial biofilms on fresh produce .....</b>	<b>96</b>
4.1 Effect of critical control parameters on ACP inactivation efficiency .....	96
4.2 Effect of food and storage conditions on ACP bacterial inactivation efficiency .....	101
4.3 Microbial biofilm formation in lettuce broth .....	103
4.4 Effect of ACP treatment on mono-culture bacterial biofilms .....	104
4.5 Effect of ACP treatment on mixed culture bacterial biofilm .....	108
4.6 Effect of ACP on bacterial populations inoculated on lettuce .....	109
4.7 Discussion .....	111
4.8 Conclusion .....	117
<b>Chapter 5 Effect of atmospheric cold plasma on bacterial stress responses and virulence .....</b>	<b>118</b>
5.1 Detection of intracellular ROS in <i>L. monocytogenes</i> after plasma treatment .....	118
5.2 ACP Inactivation efficacy associated with treatment parameters .....	119
5.3 Assessing stress responses to ACP using <i>L. monocytogenes</i> knockout mutants .....	120
5.4 Effects of ACP on <i>L. monocytogenes</i> and <i>prfA</i> mutant biofilms .....	123
5.5 Effect of ACP on gene expression of stress induced genes .....	126
5.6 Discussion .....	127
5.7 Conclusion .....	133
<b>Chapter 6 Efficacy of cold plasma functionalised water for improving microbiological safety of fresh produce and wash water recycling .....</b>	<b>135</b>
6.1 Inactivation of <i>P. fluorescens</i> on fresh lettuce by different plasma treatment methods .....	135
6.2 Antimicrobial effect of micro-bubbling plasma functionalised water on lettuce .....	136
6.3 Wash water analysis .....	142
6.4 Effect of pH .....	143
6.5 Chemical analysis .....	145
6.6 Comparison of plasma functionalised water with sodium hypochlorite washing for bacterial reduction on lettuce .....	148
6.7 Conclusion .....	150



<b>Chapter 7 ACP treatment of wastewater effluents</b> .....	<b>152</b>
7.1 Effect of retention time on bacterial inactivation .....	152
7.2 Effect of voltage level and treatment time on bacterial inactivation efficiency by ACP .....	153
7.3 Effect of the milk fat content on bacterial inactivation with ACP treatment.....	156
7.4 Inactivation of mixed culture bacteria from the wastewater effluents.....	158
7.5 Generation of reactive species .....	161
7.6 Inactivation of <i>B. megaterium</i> spores in model dairy and meat wastewater .....	163
7.7 Safety profile of ACP treated wastewater.....	166
7.8 Conclusion .....	172
<b>Chapter 8 Overall Discussion, Conclusions and Future recommendations</b> .....	<b>174</b>
<b>References</b> .....	<b>183</b>
<b>List of Publications</b> .....	<b>244</b>
<b>Conferences</b> .....	<b>245</b>
<b>Awards</b> .....	<b>246</b>

## List of Figures

Figure 1.1: A representation of the systems and their proposed roles in stress protection/adaptation in <i>L. monocytogenes</i> .....	30
Figure 1.2: The transition of states of matter on application of energy.....	39
Figure 1.3: Schematic setup of Plasma Jet.....	42
Figure 1.4: Schematic principle of Dielectric Barrier discharge (DBD) .....	43
Figure 2.1: Schematic of the experimental setup of the DBD-120 ACP plasma system.....	65
Figure 2.2: The experimental setup for treatment of lettuce and wash-water using Submerged DBD-ACP system: (a) system setup, (b) geometry of submerged DBD plasma source and (c) photograph of plasma generated in submerged DBD plasma source. ....	67
Figure 2.3: (a) Waveforms of applied voltage, discharge total current and voltage across the measurement capacitor, (b) Lissajous Q-V figure for energy consumption measurement in one period of applied voltage.....	68
Figure 3.1: Effect of plasma treatment on stationary phase- <i>B. thermosphacta</i> in PBS at 80 kV with (■) 1 h and (▨) 24 h post treatment storage time (PTST) with treatment time of 15 s, 30 s and 60 s. ....	81
Figure 3.2: Biofilm formation of <i>B. thermosphacta</i> after 24 h & 48 h of incubation at 26 °C quantified by crystal violet assay.....	85
Figure 3.3: Effect of ACP on <i>B. thermosphacta</i> 48 h biofilm formed in 12% beef extract, treated at 80 kV and assessed using (a) plate count method (b) XTT assay.....	87

Figure 3.4: Background microflora of lamb chop packaged with 30% CO <sub>2</sub> & 70% O <sub>2</sub> and treated with plasma at 80 kV for 60 s for shelf life of up to 13 days.....	89
Figure 3.5: Effect of ACP treatment (1 min at 80 kV and 24 h post treatment storage at 4 °C) on <i>B. thermosphacta</i> inoculated lamb chop packaged with 70% O <sub>2</sub> and 30% CO <sub>2</sub> concentration.....	90
Figure 4.1: Effect of acid stress and cold shock on the resistance of (A) <i>L. monocytogenes</i> and (B) <i>P. fluorescens</i> to ACP treatment.....	102
Figure 4.2: Bacterial biofilm formation after (□) 24 h (▨) 48 h of incubation quantified by crystal violet assay. Vertical bars indicate standard deviations. Column with different letters indicate a significant difference between bacterial strains and biofilm incubation time (p<0.05).....	103
Figure 4.3: Biofilm formation of dual/mixed culture bacteria.....	104
Figure 4.4: Surviving populations of 48 h mono-culture biofilm assessed by (a)Plate count (b) XTT assay after 60 s of ACP treatment at 80 kV and 24 h PTST. ....	106
Figure 4.5: Surviving populations of bacterial biofilms after ACP treatment at 80 kV and 24 h PTST assessed by:.....	109
Figure 4.6: Effect of ACP on 48 h dual bacterial biofilms of <i>L. monocytogenes</i> and <i>P. fluorescens</i> formed on lettuce at (A) 4 °C and at (B) 15 °C. ....	111
Figure 5.1: <i>L. monocytogenes</i> mutants and parent strain ROS density assay by DCFH. ....	119
Figure 5.2: Effect of ACP on <i>L. monocytogenes</i> EGD-e wild type and its knockout mutant strains. ....	120

Figure 5.3: Impact of <i>prfA</i> on biofilm formation. Biofilm formation by <i>L. monocytogenes</i> EGD-e (WT) and $\Delta prfA$ mutant at 37 °C in TSB for 48 h, quantified by (A) plate count and (B) crystal violet assay.....	124
Figure 5.4: Surviving population of 48 h <i>L. monocytogenes</i> after ACP treatment for 1, 3 and 5 min following 1 h PTST. ....	125
Figure 5.5: Effect of ACP on gene expression of stress related genes in <i>L. monocytogenes</i> EGD-e (WT). ....	127
Figure 6.1: Effect of ACP (☒) with or (■) without agitation on viable counts of <i>P. fluorescens</i> inoculated on lettuce. ....	136
Figure 6.2: Effect of ACP on (a) <i>P. fluorescens</i> (b) <i>L. innocua</i> attached to lettuce leaves for (■) 1 h and (☒) 24 h. Each column represents average bacterial population recovered after ACP treatment.....	138
Figure 6.3: SEM images of <i>P. fluorescens</i> and <i>L. innocua</i> inoculated on lettuce. The photographs represent attachment of bacteria on lettuce and after ACP treatment.....	141
Figure 6.4: Survival of (☒) <i>L. innocua</i> and (■) <i>P. fluorescens</i> in the wash water after washing lettuce in plasma functionalised water.....	143
Figure 6.5: pH value of wash water after DBD-ACP treatment.....	144
Figure 6.6: Bacterial inactivation assay in acidic solutions. <i>L. innocua</i> ( $10^{7-8}$ CFU/ml) inoculated on lettuce exposed to different acidic conditions.....	145

Figure 6.7: Concentration of (a) Nitrate and (b) Nitrite reactive species in plasma functionalised water. Experimental conditions: 1, 3, 5 and 10 min treatment at 80 kV with 0 h post treatment storage time. ND: not detectable. Vertical bars indicate standard deviation. Column with different letters indicate a significant difference between different treatment times ( $p < 0.05$ ). ..... 146

Figure 6.8: (a) Absorption spectra of Indigo Reagent degradation by submerged DBD-ACP system and (b) Concentrations of dissolved ozone in water generated during plasma exposure time. .... 148

Figure 6.9: Effect of (■) NaOCl or (●) ACP on inactivation of *L. innocua* and *P. fluorescens* on lettuce. Dotted line indicates detection limit (1.0 Log CFU/g). Vertical bars indicate standard deviation. Column with different letters indicate a significant difference between Treatment type (NaOCl, ACP) and treatment time ( $p < 0.05$ ). ..... 149

Figure 7.1: Effect of post treatment retention time (0, 5, 10 min) on stationary phase *E. coli* treated with DBD ACP system for (■) 30 s and (▨) 60 s and at 80 kV in phosphate buffer solution..... 153

Figure 7.2: Effect of ACP treatment time on stationary phase (▲) *E. coli* (■) *E. faecalis* and (●) *C. perfringens* in model (A) dairy (B) meat wastewater treated at 80 kV with post treatment retention time of 10 min. Dotted line indicates limit of detection (1 Log<sub>10</sub> CFU/ml). Vertical bars represent standard deviation. Column with different letters indicate a significant difference between three bacterial samples, their controls and ACP treated samples ( $p < 0.05$ ). ..... 155

Figure 7.3: Inactivation of *E. coli* in stationary phase suspended in model dairy wastewater at different fat content (■) 0.2 g/L (▲) 2 g/L and (●) 4 g/L..... 157

Figure 7.4: Inactivation of mixed culture bacterial strains of (■) *C. perfringens* (●) *E. coli* (▲) *E. faecalis* in stationary phase suspended in model dairy and meat wastewater treated with ACP treatment at 80 kV..... 160

Figure 7.5: Generation of (A) Hydrogen peroxide and (B) Nitrate in model dairy wastewater after ACP treatment. (▨) 0.2 g/L (▩) 2 g/L (■) 4 g/L..... 162

Figure 7.6: Time depended inactivation of stationary phase *B. megaterium* (●) vegetative cells and (■) spores by ACP treatment at 80 kV..... 164

Figure 7.7: ACP inactivation of *B. megaterium* spores suspended in (▲) PBS (■) model meat wastewater (●) model dairy wastewater..... 165

Figure 7.8: Percentage cytotoxicity of RTG-2 cells after 24 h exposure to model dairy and meat wastewater treated with plasma at 80 kV for 5 and 10 min. ▨ Alamar blue ■ Neutral red. Vertical bars represent standard deviation. Column with different letters indicate a significant difference between controls and ACP treated samples ( $p < 0.05$ ). ..... 168

Figure 7.9: Percentage cytotoxicity of PLHC-1 cells exposed to different concentrations of model dairy and meat wastewater treated with plasma at 80 kV for 5 and 10 min. ▨ Alamar blue ■ Neutral red. Column with different letters indicate a significant difference between controls and ACP treated samples ( $p < 0.05$ ). ..... 168

Figure 7.10: Percentage mortality or immobilisation after 48 h exposure to model wastewater plasma treated using DBD-120 system at 80 kV for (●) 5 min (■) 10 min with 10 min of PTRT..... 170

## List of Tables

Table 1.1: Examples of foodborne illness outbreaks linked to fresh produce from 2011 to 2018.....	2
Table 1.2: Estimated values of wastewater generated by Food Industry.....	11
Table 1.3: Summary of common methods of wastewater treatment .....	17
Table 1.4: Wastewater discharge standards in Ireland.....	17
Table 1.5: Factors identified to have an impact on the growth and survival of <i>L. monocytogenes</i> .....	30
Table 1.6: Applications of non-thermal plasma for inactivation of microorganisms on food matrices.....	49
Table 2.1: Bacterial strains used in this study.....	55
Table 2.2: List of knockout mutants and their characteristics .....	56
Table 3.1: Effect of ACP on <i>B. thermosphacta</i> inactivation in PBS at different voltage levels after 1 h and 24 h PTST .....	82
Table 3.2: Surviving numbers of stationary phase <i>B. thermosphacta</i> in PBS and 3% beef extract after ACP treatment at 80 kV and 24 h post treatment storage time. ....	84
Table 3.3: In-package ozone and carbon monoxide concentration measured inside the sealed trays after plasma treatment at 80 kV .....	91
Table 4.1: Effect of voltage on plasma inactivation efficacy in PBS .....	98

Table 4.2: ACP inactivation efficacy against planktonic stationary phase bacterial populations, treated at 80 kV with different treatment and post-treatment storage times .....	100
Table 5.1: Influence of cold stress (4 °C) on ACP inactivation efficacy for <i>L. monocytogenes</i> EGD-e (WT) and its mutant strains. ....	122
Table 5.2: Effect of pre-exposure to mild acid condition (pH 4) on ACP inactivation efficacy for <i>L. monocytogenes</i> EGD-e (WT) and mutant strains. ....	123
Table 6.1: Washing lettuce with sterile deionised water with microbubbles and agitation in submerged DBD system without plasma treatment.....	137
Table 7.1: Effect of Atmospheric cold plasma on bacteria inactivation at various applied voltage levels with 10 min Post treatment retention time.....	154
Table 7.2: EC <sub>50</sub> values of ACP treated water wastewater for cytotoxicity test .....	166
Table 7.3: EC <sub>50</sub> values of ACP treated model wastewater for acute daphnia toxicity test....	169



## List of Abbreviations

16S	Small ribosomal subunit
ACP	Atmospheric cold plasma
AI-2	Autoinducer 2
ANOVA	Analysis of Variance
ATP	Adenosine triphosphate
BE	Beef extract
BOD	Biological oxygen demand
C56A	cysteine replaced by alanine at amino acid 56
CaCl <sub>2</sub>	Calcium chloride
CFU/ml	Colony forming unit per millilitre
COD	Chemical oxygen demand
DBD	Dielectric barrier discharge
DBP	Disinfection by-product
DCFH-DA	2',7'-dichlorodihydrofluorescein diacetate
DE	Dairy effluent
DNA	deoxyribonucleic acid
dNTP	deoxynucleotide acid
EC <sub>50</sub>	concentration of toxin required to cause a specified effect on 50% of the test organisms
EPA	Environmental protection agency
EPS	Extracellular polymeric substances
FI	Food Industry
g	Gram
HCl	Hydrochloric acid

HEPES	4-(2-hydroxyethyl)-1-piperazineethanesulfonic acid
Hz	Hertz
K	Kelvin
KI	Potassium iodide
kV	Kilovolt
LB	Lettuce broth
L	Litre
Log	Logarithm
M	Molar
MAP	Modified atmosphere packaged
ME	Meat effluent
mM	millimolar
MRD	Maximum recovery diluent
NaOCl	sodium hypochlorite
OD	Optical density
PAW	Plasma activated water
PBS	Phosphate-buffered saline
PCR	Polymerase chain reaction
PLHC-1	Pociliopsis lucida hepatocellular carcinoma cell
PTRT	Post treatment retention time
PTST	Post treatment storage time
qRT-PCR	quantitative real-time PCR
QS	Quorum sensing
RNA	ribonucleic acid

RNS	Reactive nitrogen species
ROS	Reactive oxygen species
RONs	Reactive oxygen nitrogen species
rpm	Revolutions per minute
RTG-2	Rainbow trout gonad cells
SEM	scanning electron microscopy
SD	Standard deviation
spp	species
TSA	Tryptic soy agar
US EPA	United States Environmental Protection Agency
VNBC	Viable but non-culturable
v/v	volume per volume
WHO	World health organization
WT	wild-type

## **Symbol**

$\Delta$	deletion mutant
$^{\circ}\text{C}$	degrees Celsius
$\sigma$	Sigma (Sig)
$\mu\text{M}$	micromolar
$\mu\text{l}$	microliter

## Chapter 1 Introduction

### 1.1 Microbiological challenges associated with fresh-cut and minimally processed produce

The role of fresh vegetables and fruits in a nutritious and healthy diet are well recognised. Hence, significant rise in the consumption of fresh produce for health benefits has occurred with rise in lifestyles and major shifts in consumption trends. Amongst them, the intake of fresh-cut or minimally processed produce has undergone sharp increases. Fresh-cut products are in a raw state, fresh like produce which could be minimally/partially processed without freezing, preservatives, canning, fermentation or acidification process. A Food and Agriculture organization statistical database (FAOSTAT., 2013) report indicated an overall 38% increase in production of fresh fruits and vegetables worldwide between 2000 and 2011. The region of Europe and Central Asia produced 136 million tonnes of vegetables in 2010. However, the incidences of foodborne outbreaks linked to contaminated fresh produce have also increased (Mukherjee *et al.*, 2006) becoming the fourth highest for foodborne illness since 1990 (Varzakas and Arvanitoyannis, 2008). In 2016, a total of 4,786 food-borne outbreaks, including waterborne outbreaks were reported in the EU, resulting in 49,950 cases of illness, 3,869 hospitalisations and 20 deaths (EFSA, 2017). This trend has continued and prevention of contamination in fresh fruits and vegetables as well as fresh produce outbreaks has become a major food safety challenge. Fresh produce remains the leading cause for foodborne illness outbreaks implicating virulent pathogens such as *Escherichia coli*, *Salmonella typhimurium*, *Listeria monocytogenes*, viruses (Hepatitis A), protozoa (*Cryptosporidium parvum*) and increasingly human parasites (Callejón *et al.*, 2015) with *E. coli*, *L. monocytogenes* and *Salmonella* sp. being the leading cause of the foodborne outbreaks (Crowe *et al.*, 2015; Olsen *et al.*, 2000). Consumption of these foodborne

pathogens can lead to severe illnesses, hospitalisation and in some cases even death. Some examples for foodborne illness linked to fresh produce are represented in **Table 1.1**.

**Table 1.1: Examples of foodborne illness outbreaks linked to fresh produce from 2011 to 2018 (source: CDC, 2018)**

<b>Year</b>	<b>Product</b>	<b>Pathogen</b>	<b>No. of cases</b>
2018	Fresh Produce vegetable trays	<i>Cyclospora</i>	237
2018	Pre-Cut Melon	<i>Salmonella</i> Adelaide	77
2018	Romaine Lettuce	<i>E. coli</i> O157:H7	210
2017	Leafy Greens	<i>E. coli</i> O157:H7	25
2017	Maradol Papayas	<i>Salmonella</i> : Thompson, Kiambu, Agona, Gaminara, and Senftenberg	220
2016	Frozen strawberries	Hepatitis A	143
2016	Frozen vegetables	<i>L. monocytogenes</i>	9
2016	Packaged salads	<i>L. monocytogenes</i>	19
2015	Cucumbers	<i>Salmonella</i> Poona	907
2014	Caramel apples	<i>L. monocytogenes</i>	35
2014	Cucumbers	<i>Salmonella enterica</i> Newport	275
2013	Ready to eat salad	<i>E. coli</i> O157:H7	33
2013	Salad mix	<i>Cyclospora cayetanensis</i>	631
2013	Cucumbers	<i>Salmonella enterica</i> Saintpaul	84
2012	Organic spinach/spring mix blend	<i>E. coli</i> O157:H7	33
2012	Mangoes	<i>Salmonella</i> Braenderup	127
2012	Cantaloupe	<i>Salmonella enterica</i> Typhimurium and Newport	261
2011	Romaine lettuce	<i>E. coli</i> O157:H7	58
2011	Cantaloupe	<i>L. monocytogenes</i>	147
2011	Papaya	<i>Salmonella</i> Agona	106
2011	Cantaloupe	<i>Salmonella enterica</i> Panama	20

Other than pathogenic microorganisms, there are several spoilage organisms that can enter the plant tissue through wounds and cause spoilage. The causative agents for spoilage in fresh produce are *Erwinia carotovora*, *Pseudomonas spp.*, *Xanthomonas campestris*, lactic acid bacteria (*Leuconostoc mesenteroides*), *Botrytis*, *Alternaria*, *Sclerotinia* and *Rhizopus*, with *E. carotovora* and *Pseudomonas fluorescens* being the most common spoilage causing bacteria, attacking virtually every vegetable type (Tournas, 2005). Spoilage in general is characterised by soft, watery and slimy appearances which are responsible for tuber rot, soft rot and black rot type of spoilage in vegetables.

The open nature of the fresh produce production process makes it susceptible to multiple sources of contamination. Vectors responsible for transmission of these microbes onto the produce include soil particles, airborne spores, biological amendments and faecal contaminated irrigation water. Fresh produce can get contaminated during growth in field, during harvesting, post-harvest handling or during storage and distribution (Nüesch-Inderbilen and Stephan, 2016; Olaimat and Holley, 2012). Pathogens and spoilage microorganisms can survive for extended periods within the environment and become widely distributed. Under ideal conditions, they colonise, creating lesions and internalising in healthy plant tissue. Internal tissues are rich in nutrients (water activity,  $a_w > 0.90$ ) and have neutral pH which provide the microorganism ideal conditions to grow and multiply inside the produce (Barth *et al.*, 2009). During the production of fresh-cut or minimally processed fruits and vegetables, washing has been identified as a potential pathway for dispersion of microorganisms and more specifically *E. coli* to the end product (Holvoet *et al.*, 2012). Although washing with water or disinfectants helps remove significant number of microbes, the ability to eliminate naturally present microorganisms from fresh produce is limited (Banach *et al.*, 2015). Attachment of pathogens to surfaces and internalisation of pathogens within the plant tissues limits the efficacy of conventional processing and sanitising methods

in preventing transmission from contaminated produce. The survival and growth of foodborne pathogens depends on environmental conditions in the field and during storage, microorganism and the produce item involved. Minimally processed fresh produce possess an additional risk of food safety as they are consumed raw fresh produce can serve as a vehicle for many food-borne pathogens to survive and cause human infections (López-Gómez *et al.*, 2018).

### **1.1.1 Pathogens of concern for fresh food and fresh food processing environment**

#### ***Listeria* species**

*Listeria* spp. are Gram-positive, non-spore forming, non-capsulated, facultative anaerobic bacteria. The *Listeria* genus mainly include *L. monocytogenes*, *L. ivanovii*, *L. innocua*, *L. welshimeri*, *L. seeligeri* and *L. grayii*, however the *Listeria* spp. has expanded over the past few decades and currently contains 11 other species (Bertsch *et al.*, 2013; Orsi and Wiedmann, 2016). Of these species, *L. monocytogenes* (foodborne human pathogen) and *L. ivanovii* (animal pathogen) are documented pathogenic strains. *L. monocytogenes* persist within the human gastrointestinal tract and are known to cause Listeriosis. It is an important foodborne pathogen of public health and food safety significance. In 2015, the EU reported 2,206 numbers of confirmed cases of Listeriosis in humans and approximately 964 hospitalisations (EFSA, 2017).

*L. monocytogenes* can be classified into 13 serotypes (Seeliger and Höhne, 1979) ) of which serotypes 1/2a, 1/2b, 1/2c and 4b are the most frequently isolated from food or food production environments and are primarily responsible for causing Listeriosis (Pan *et al.*, 2009; Swaminathan and Gerner-Smidt, 2007). The commonly used lab strains EGD-e, EGD and 10403S belonging to serovar 1/2a, appear to be increasingly associated with human infections. In 2011, the strains (type 1/2a and 1/2b) were implicated in US multistate cantaloupe-associated listeriosis outbreak which resulted in 147 deaths (McCollum *et al.*,

2013). *L. monocytogenes* are ubiquitous and can be isolated from soil, wastewater, sewage, a and wide variety of vegetables like lettuce, celery, potatoes, tomatoes, broccoli etc. (Beuchat, 1996). Several studies conducted have indicated the prevalence of *L. monocytogenes* in fresh-cut produce (Oliveira *et al.*, 2014; Vandamm *et al.*, 2013). It is an important pathogen of concern in fresh produce due to its ability to tolerate a wide pH range (4-9), low water activity (Gandhi and Chikindas, 2007) and also a variety of stress conditions including low temperatures, high salt conditions and gas atmospheres commonly present in modified atmosphere packaging (MAP) (Capozzi *et al.*, 2009). This endows the bacterium capacity to survive in varied food processing and storage conditions. It can not only be found on the food products but also can attach and form biofilms on any food processing equipment (Beresford *et al.*, 2001). Biofilm forming capacity of *L. monocytogenes* makes it difficult to control and eradicate it completely from the fresh produce. Since bacterial cells can easily be transferred from biofilms to food products, biofilms containing pathogenic bacteria such as *L. monocytogenes* are of particular concern for food industries.

### ***Escherichia coli***

*Escherichia coli* is a Gram negative, short rod shaped bacteria with cells varying from cocci to long filamentous structure (Percival *et al.*, 2004). It is a normal facultative anaerobic microflora of the human and animal intestine. Though they are harmless commensals, various *E. coli* strains have acquired genetic determinants (virulence genes) rendering them pathogenic to humans and animals (Holko *et al.*, 2006). *E. coli* is the best indicator for faecal contamination of water and food products. Pathogenic *E. coli* are categorised to specific groups on the basis of serological & virulence characteristics, mechanisms of pathogenicity, clinical symptoms: entero-pathogenic (EPEC), entero-toxegenic (ETEC), entero-haemorrhagic (EHEC), entero-invasive (EIEC), entero-aggregative (EAggEC) (Holko *et al.*, 2006; Percival *et al.*, 2004). The EHEC strain, *E. coli* O157:H7 has become an important



pathogen of concern for the food and dairy industries for its ability to survive and grow at acidic environments (Tsegaye and Ashenafi, 2005) and cause infection at low doses, that is with less than 100 cells (Bitton, 2005). *E. coli* O157:H7 is reported to survive in acidic foods such as refrigerated apple cider (Besser *et al.*, 1993) and yogurt (Tsegaye and Ashenafi, 2005). It has the ability to cause diverse illnesses such as haemorrhagic colitis, haemolytic uremic syndrome, septicaemia and meningitis (McClure, 2005). Food and water are important sources of transmission for this pathogen. Several outbreaks of *E. coli* gastroenteritis are associated with contamination in food processing industries including milk (Leedom, 2006), cheese, fresh produces (Critzler and Doyle, 2010), meat (Zhao *et al.*, 2001) and water (Friedman *et al.*, 1999). Reports for infections caused by *E. coli* has been increasing worldwide (CDC, 2016) which has classified the specific serotype *E. coli* O157:H7 as a current pathogen of concern.

### ***Salmonella***

*Salmonella* spp. are Gram negative, facultative anaerobic and rod-shaped bacteria. The *Salmonella* genus has more than 2700 serotypes identified, and they are all are major concern to almost all sectors of the food industry. Surveys have indicated the presence of several serotypes responsible for disease in both humans and animals (U.S. Food and Drug Administration, 2015). Poultry, eggs, dairy, fresh fruits and vegetables are commonly implicated sources in Salmonellosis outbreaks. Amongst them is the *Salmonella bairdson* outbreak associated with shredded lettuce, dried tomatoes which was isolated from patients in geographically separate areas of the U.S (FDA, 2016). *Salmonella* was identified as one of the most frequent cause of foodborne outbreaks with serovars *Salmonella enteritidis* and *Salmonella typhimurium* being most frequently associated with human illness (EFSA, 2015a). *Salmonella* spp. are resistant pathogens that can adapt to various environmental stress conditions. It has been reported to grow at elevated temperatures, pH ranging from 4.5 to 9.5

(optimum pH for growth at 6.5 to 7.5) as well as in environments with high salinity (>2% NaCl) (Montville and Matthews, 2008). They have also been reported to survive under freezing conditions for prolonged periods. Many factors may enhance the prevalence of *Salmonella* in foods, which includes: physiological state of the food, water activity ( $a_w$ ), nutritional state of the foods and serovar specific responses.

Illness caused by *Salmonella* serotypes range from gastroenteritis to enteric (typhoid) fever, septicaemia and chronic sequelae (Forshell and Wierup, 2006). Epidemiologic evidence has indicated low doses of the bacteria to cause an infection. The virulence plasmids present within the genus may enable the bacteria to rapidly multiply within and host the overcome the host defence mechanisms. Several virulence determinants are responsible for *Salmonella* spp. to cause disease, such as the genes involved in nutrient synthesis, stress response and cell damage repair.

### ***Bacillus megaterium***

The *Bacillus* genus, part of the *Bacillaceae* family, is probably the oldest and most diverse genus of bacteria. *B. megaterium* is a Gram-positive aerobic spore-forming bacterium, cell ranging in size from 1.5 by 4  $\mu\text{m}$  and is the largest of all Bacilli. They are ubiquitous in nature found widely in almost all habitats including soil, air, lake sediments, water, dried foods as well as extreme environments such as thermal acid water, salt marshes and diseased bee larvae (Vos *et al.*, 2011). *Bacillus* species spores are dormant and are extremely resistant to environment stress including heat, radiation, desiccation, mechanical disruption and high level of toxic chemicals such as strong oxidisers and pH change agents (Setlow, 2007; Setlow and Johnson, 2013). The spores possess a robust physical barrier and metabolic activity is not influenced by chemically aggressive species. They are also known to play an important role in detoxifying chemicals due to the presence of enzymes in the spore surface layers i.e. in the bacterial spore coat (Henriques and Moran, 2007).

As most of the bacterial spores are abundant in the environment, they are a major threat to food safety and public health. Previous studies have indicated the presence of higher concentration of aerobic spore forming bacilli in surface or treated water than *Clostridium perfringens* as well as parasite protozoan cysts (Bitton, 2011). Several studies have suggested the use of *Bacillus* spores as a surrogate for assessment of water treatment technologies with regards to the removal of *Cryptosporidium* and *Giardia* cysts (Nieminski *et al.*, 2000; Rice *et al.*, 1996). Due to distinctive limitations and resistance of bacilli spores to conventional treatment methods, there is need for an effective sterilisation method for complete inactivation and destruction of bacterial spores.

### **1.1.2 Spoilage bacteria of concern associated with food and food processing environments**

#### ***Brochothrix thermosphacta***

*B. thermosphacta* is a common food spoilage agent, which grows on raw food, lightly preserved meat products and meat processing facility surfaces (Nychas *et al.*, 2008). Its ability to survive and grow in the otherwise challenging environments implemented in meat processing and preservation indicate the need for alternative decontamination and control measures. It is a facultative anaerobe able to tolerate growth at variable temperatures of 0-30°C, pH 5-9 (Collins-Thompson and Rodriguez Lopez, 1980), within water activity range of 0.94–0.99 (Gardner, 1966) and tolerates up to 10% NaCl (Erkmen, 2000; Gribble and Brightwell, 2013). The bacterium displays lipolytic activity also under refrigeration temperature (Nowak *et al.*, 2012) in prepacked and vacuum packed meat products (Gardner, 1966) which helps the bacteria to grow under O<sub>2</sub> depletion and in presence of CO<sub>2</sub> concentrations (Pin *et al.*, 2002). *B. thermosphacta* produces volatile compounds such as acetoin, diacetyl (aerobic growth), or lactic acid and ethanol (anaerobic growth) causing flavour deterioration and strong off-odour in meat (Borch *et al.*, 1996; McLean and

Sulzbacher, 1953; Stanley *et al.*, 1981). These characteristics reveal why *B. thermosphacta* is a significant meat coloniser and food spoilage causing bacteria (Ercolini *et al.*, 2006). Globally, *B. thermosphacta* is addressed as a pre-dominant organism responsible for meat spoilage therefore is of importance for trade of fresh meat products.

### ***Pseudomonas* species**

*Pseudomonas* spp. is most frequently reported bacteria genus found in food processing environments and across all types of foods. *Pseudomonas* spp. are versatile psychrotrophs commonly associated with spoilage of fresh foods because of their widespread existence in water, soil and vegetation under both optimal as well as refrigeration temperatures. They are frequently introduced into the food processing environment through several routes. Also, they are ubiquitous, they acquire different niches in the production environment with respect to nutrients, temperatures, surface materials, and stress factors (Møretrø and Langsrud, 2017). Four species of *Pseudomonas* commonly associated with food spoilage are *P. fluorescens*, *P. corrugata*, *P. putida* and *P. marginalis*. Soft rots in plant derived food occurs when pectin that hold plant cells together are degraded by pectic lyases enzyme secreted by *P. fluorescens* and *P. viridiflava* (Rawat, 2015). This results in maceration of the host tissues. Other tissue degrading enzymes produced by these spp. include cellulases, xylanases, glycoside hydrolases and lipoxygenase (Gross and Cody, 1985; Zhuang *et al.*, 1994). They are capable of synthesising enzymes even under refrigeration temperatures and cause food spoilage. *Pseudomonas* spp. are of great importance amongst products that are stored at low temperatures. They grow and multiply continuously in refrigerated products causing putrefactive odours and slime (Raposo *et al.*, 2017). *Pseudomonas* spp. are also characterised as quick and thick biofilm producers. Biofilm formation is relatively extensive in *Pseudomonas* at temperatures relevant to food production; studies by Liu *et al.* (2015) demonstrated maximum biofilm formation of *P. lundensis* at refrigeration temperatures (4 °C

and 10 °C) than at higher temperature (30 °C). *Pseudomonas* spp. are also highly capable of competing with other food associated microbes; several characteristics of *Pseudomonas* spp. explain its dominance and persistence in combination with other bacteria (Langsrud *et al.*, 2016). Studies have revealed *P. fluorescens* interactions with other bacterial strains such as *L. monocytogenes* which leads to increased colonisation and resistance of this pathogenic bacterium from disinfection and sanitising agents (Carpentier and Chassaing, 2004). Similarly, a mixed biofilm of *P. fluorescens* and *B. cereus* demonstrated increased tolerance to surfactant and aldehyde when cultivated in a rotating stainless-steel device for 7 days (Simões *et al.*, 2009). Resistance against these disinfection agents makes the bacterium of great concern in food processing industry.

## **1.2 Microbiological concern associated to food industry wastewater treatment**

In most food industries, water is the most used raw material for the production of high value products. They are the major consumer of Earth's fresh water; with more than 66% of the fresh water abstractions worldwide go towards food production (Kirby *et al.*, 2003). Water plays a vital role in the food industry with large volumes of wastewater from various processing steps including cooling, heating, extraction, reaction by-products, washing, cleaning, sanitisation and various steps in the manufacturing of food products themselves. Food processing industries are one the largest source of wastewaters, with a trend of increasing volumes being produced (Valta *et al.*, 2015). The physical and chemical properties of the effluents derived from the food sector vary in line with the product type, manufacturing subsets, applied process and the capacity of the plant. The main contaminants are microorganisms, sanitising products, pesticides, metals, nutrients (proteins, carbohydrates, fats, minerals), organic and inorganic materials, with high variation in pH (Bustillo-Lecompte *et al.*, 2013; Gough *et al.*, 2000; Perle *et al.*, 1995). Industrial wastewater is difficult to characterise, as the quality and quantity of wastewater produced by a particular

industry depends on the type of the processing plant, plant size and processing step involved (Bustillo-Lecompte *et al.*, 2014; Cristian, 2010). It may vary according to processes, season and related products.

According to report by World Water Assessment Programme (WWAP., 2012), about 80% of wastewater is released into the environment with inadequate treatment which further contributes to degradation of water quality. Consequence of releasing untreated/inadequately treated water into the environment include direct impact on human health, environment (water bodies and its ecosystem) and subsequently affecting economic activities such as industrial production, fisheries, aquaculture and tourism (Hernández-Sancho *et al.*, 2015). The average values of wastewater generated by the major food processing sectors reported are given in the **Table 1.2**. The general requirements for discharges from urban wastewater treatment plants are 25 mg/L for Biological oxygen demand (BOD), 125 mg/L for Chemical oxygen demand (COD) and Total suspended solids of 35 mg/L (The Council of the European Communities, 1991) .

**Table 1.2: Estimated values of wastewater generated by Food Industry**

<b>Industry type</b>	<b>TOC</b>	<b>COD</b>	<b>BOD</b>	<b>pH</b>
	<b>(mg/L)</b>	<b>(mg/L)</b>	<b>(mg/L)</b>	
Dairy products <sup>a</sup>	850-1300	1400-3000	1100-1800	6.9-7.5
Meat and Poultry <sup>b</sup>	50–1750	500-16,000	2-7	4.9–8.1
Vegetables, fruits <sup>c</sup>	249-420	919-3700	860-3200	4.6-7.9

<sup>a</sup>(Shete and Shinkar, 2013), <sup>b</sup>(Bustillo-Lecompte and Mehrvar, 2017),

<sup>c</sup>(Puchlik and Struk-Sokołowska, 2017)

### **1.2.1 Food industry (FI) and their characterisation**

#### **Dairy Industry**

The dairy industry is one of the largest sources of the wastewater effluents in regard to the volume of the water consumption by the industry. A typical European dairy generates approximately 50 m<sup>3</sup> wastewaters per day. The main liquid waste types (e.g. product residue and waste generated from cleaning) and the quantities of their key pollution indicators (BOD, COD, suspended solids, total nitrogen, total phosphate, and total oils, fats and greases) in Europe are documented Annual Environmental Reports on Environmental Protection Agency (EPA) website (Valta *et al.*, 2015). Most of the waste generated in dairy industry is liquid which comprises of volatile milk constituents, fats and proteins of milk and milk products being processed. The need for water in the dairy industry is huge; water is used throughout all steps such as sanitisation, heating, cooling milk processing, cleaning and packaging (Barbera and Gurnari, 2018). In general, the composition of dairy wastewater is correlated to BOD and COD values representing the high organic content (Shete and Shinkar, 2013). These effluents have different characteristics depending on the final products; generated volume and based on the processing plant. Each division produces a characteristic composition of wastewater depending on the product produced (cheese, butter, milk powder, yogurt). The range of production of wastewater is highly influenced by management practices and the design of the plant.

Milk and milk products can harbour a variety of microorganisms and can be important sources of foodborne pathogens. The presence of these pathogens is due to its contact with its source, that is the dairy environments and excretion from the farm animals (Oliver *et al.*, 2005). There are major concerns over the contamination with soil, water and air when they come in contact with solid or liquid surface. With a notable concentration of organic matter and pathogens these effluents may create serious burdens on the industry treatment systems.

## **Meat processing industry**

Meat processing industry produce large volumes of wastes mainly produced from slaughtering of animals, cleaning and sanitisation of equipment, slaughter house facilities and meat processing units. Preparation of meat products is a multi-stage process that generates wastewater after each respective step. The meat industry uses 24% of the total freshwater to that consumed by food and beverage industry (FAO, 2013). Over the past few years, the global meat industry has increased and is projected to see a doubling of production (FAO, 2013).

Meat wastewater compositions vary significantly depending on the industrial process and specific water consumption. The effluent from the meat industries contains heavy loads of organic wastes like blood, loose meat, soluble proteins, fats, greases, oils and solid wastes. They may also contain high concentrations of nitrogen, phosphorous and Total Suspended Solids (TSS); which may cause deoxygenation of water bodies and contamination of ground water (US EPA, 2004). Wastewater from slaughter houses is considered as the most harmful wastewater for environment by the US EPA. Release of these effluents into the environment causes deleterious effect on aquatic life as well as effect on the water quality thus impacting further reusability of water.

## **Fresh produce effluent**

Water is critical for the fresh produce industry, most of the products are washed, cooled, or transported using water. Most of the food processing involves cleaning, trimming, shredding, slicing, washing, drying and packaging (Yildiz, 1994). The washing with water is a common preliminary step used to remove soil, debris, exudates, microorganism from fresh fruits and produces. Like in the case of minimally processed food products, fresh produce are cleaned, washed, cut, packed and sold as ready to eat foods. The entire treatment and packaging cycle for these products relies on the use of water. Difference in water quality produced can be



found in different commodities and postharvest operations of fresh and fresh-cut produce (S. Van Haute *et al.*, 2015). The wastewater resulting from these washes contain high concentrations of organic matter including carbohydrates and minerals depending on the raw material processed or time of the year. Differences in the microbial population load can be observed due to the seasonal nature of the processed commodities (Valta *et al.*, 2016).

In case of the fresh and fresh-cut products, wash water after contact with the raw produce and after rinsing and washing are important source of organic compounds, pesticides, and bacteriological contamination (Gil and Allende, 2018). The high organic content of the wash water potentially encourages growth of microbial populations. Washing has been identified as a potential pathway for dispersion of microorganisms during fresh produce processing, and if a pathogen is present in this water, they can be distributed on the end product via cross contamination (Holvoet *et al.*, 2012). In many countries for economic and environmental reasons, water re-use has become a valuable practice in fresh produce industry (US Environmental Protection Agency, 2012). However, water and wastewater utilisation, costs of treatment and disposal guidelines remains a critical factor for sustainable use of water.

### **1.2.2 Pathogens of relevance related to wastewater treatment**

Apart from high organic loads, pathogenic microorganisms are widely found in the wastewater effluents released from the food industry. Such environments are an ideal place for the growth of both pathogenic and spoilage microorganisms. The key sources of contamination can be from the farms (the environment itself: soil, water, human contact), collection and process equipment on the farm and in the industry. Several previous studies have shown significant microbial concentrations and potential presence of pathogens in the food processing industrial environment (McGarvey *et al.*, 2004; Parkar *et al.*, 2015). A wide range of microbial profiles are present in food industry effluent like *Cryptosporidium*, *Giardia*, *Escherichia coli*, *Clostridium perfringens*, *Enterococcus faecalis*, *Salmonella*,

*Bacillus* species etc. Entry of foodborne pathogens via contaminated food and milk products into the dairy-food processing plant leads to persistence and establishment of pathogens in the form of biofilms or bacterial endospores/spores. Inadequate processing and treatment of these effluents may lead to survival of these pathogens and result in public health concerns. The primary concern with food industry waste is the organic load present which may act as food sources for microbial growth. Microorganisms therefore, continue to grow and proliferate rapidly causing a significant rise in biological oxygen demand (BOD), chemical oxygen demand (COD) and total suspended solids (TSS) content in industrial wastewaters. Water reuse has been gaining momentum as an alternative reliable source of fresh waters for food processing industries (WWAP, United Nations World Water Assessment Programme, 2017). Environmental and public health risk is an important aspect of water re-use; cleaning and effective treatment is therefore important to guarantee quality and safety of the recycled water. If the water is inadequately treated, they can promote cross-contamination; affect the entire food processing plants as well as the food end products. The presence of bacteria in the water source is of utmost concern due to their virulence which poses a serious threat to public health. Pathogenic bacteria derived from food processing industries are exposed to several high doses of chemical and antibiotics which might additionally benefit the bacteria in gaining resistance (Capita and Alonso-Calleja, 2013).

### **1.2.3 Current Treatment measures**

The importance of treating wastewaters from the food industry has become an important process particularly given the number of contaminants and volume of wastewaters discharged from these industries. In almost all the treatment processes, the approach is more oriented towards protection of the environment rather than conserving and reuse of the treated water. Several R&D activities are implemented in industries to reduce the environment pollution and discharge of effluent waters by adopting advanced technologies. Industries are

continuously seeking to implement advanced innovative methods to combat the environmental impact of the wastewaters discharged.

In practice, there are several treatment methods that are applied to wastewater effluents from food processing industries. The contaminants in wastewaters released from major food sectors include suspended solids, organic/inorganic materials, toxins and vaccines, BOD and COD components and microorganisms (Barbera and Gurnari, 2018). Primary treatment is aimed in reducing the large particles such as grits, floatables, grease, settleable suspended solids which could influence the proper functioning of a water treatment plant. The physical treatments used at this stage namely filtration and sedimentation remove suspended solids and BOD with organic and inorganic matter from the wastewaters (EPA, 1997). Water disinfection technology is applied at the final stage of the water treatment process, before releasing it into the water body. The main goal of the disinfection is to prevent large concentrations of microorganisms and other suspended particles that survived previous treatment from reaching waterways (Spellman, 2014). The selected application treatment method primarily depends on nature and physiological properties of the wastewater. An optimum and effective disinfection method is difficult to select because of the limitations that some treatments may represent when eliminating microorganism of public risk, coupled with the potential for the introducing disinfection by-products (DBP's) that may have formed or accumulated through the treatment process (Spellman, 2014). There are various traditional methods applied for wastewater treatment, each system having their own advantages and disadvantages. Some of the common disinfection methods employed at various stages in food industry are summarised in **Table 1.3**.

**Table 1.3: Summary of common methods of wastewater treatment**

Treatment operations	Performance	Reference
Electrocoagulation	BOD by 27.02% and TSS by 85.7%	(Zuhria <i>et al.</i> , 2018)
UV Photolysis and Ozonation	64% COD reduction	(Jing and Cao, 2012)
Advanced oxidation process	76.70-90.70 % COD reduction	( Karagozoglu, 2014)
Gamma radiation	38.65-85.75 % BOD removal	(Melo <i>et al.</i> , 2008)
Ultrafiltration	>99.8% for TOC and >99.5% for lactose	(Vourch <i>et al.</i> , 2008)
Ozonation	88 % COD removal, 68% BOD	(Martínez <i>et al.</i> , 2011)
Ultraviolet radiation	<12 mJ/cm <sup>2</sup> for a 4 Log <sub>10</sub> reduction in bacterial inactivation	(Rose and O'Connell, 2009)

PAC: Polyaluminum chloride; BOD: Biological oxygen demand; COD: Chemical oxygen demand; TOC: Total organic carbon

Ultimately the selection of an appropriate treatment process depends on the characteristics of the wastewaters as well as specific regulations. Wastewater discharge standards in Ireland follow European wastewater legislations as shown in **Table 1.4**.

**Table 1.4:Wastewater discharge standards in Ireland (EPA., 2013)**

Parameters	Concentration (mg/L)	Minimum reduction (%)
BOD <sub>5</sub> without nitrification	25	70-90
COD	125	75
TSS	35	90
TP	1 - 2	80
TN	10 - 15	70-80

BOD: Biological oxygen demand; COD: Chemical oxygen demand; TSS: Total organic carbon; TP: Total phosphorous; Total Nitrogen: Total nitrogen

Previous studies with treatment technologies have demonstrated the effective removal of organic matter but were not capable of completely eliminating emerging contaminants such as neurotoxins, trichloroethene and resistant microorganism from the wastewaters. Traditional treatment methods could be limited by a number of factors such as high energy consumption, climate, temperature, higher retention time, larger volume reactors, higher contaminants level and resistance of the microorganisms to certain chemicals. Another disadvantage of some these treatment methods are the toxic disinfection by-products which are formed when disinfectants react with certain reactants present in the water effluent such as Trihalomethanes (Van Haute *et al.*, 2013) which is a major risk to environment and public health. Further details on current decontamination method applied in food industry for treatment of food products and wastewater generated is discussed in Section 1.4.

### **1.3 Microbial resistance**

#### **1.3.1 Bacterial Internalisation**

An important factor associated with fresh produce contamination and increased resistance of bacteria to antimicrobials is the ability of bacteria to internalise inside plant tissue. Bacterial pathogens may enter fresh produce through both natural (intercellular tissues, stomata, lenticels, lateral junction of roots) and damaged (wounds, cuts) tissue sites (Erickson, 2012). These habitats provide stress protective niches for bacteria which also serve as rich sources of water and nutrients (Yaron and Römling, 2014). Fresh produce can become contaminated by pathogenic bacteria at any point along the farm-to-table food chain (production, harvesting, processing, packaging and handling). Several studies have shown that human pathogens can enter the stomata and cut edges of the fresh produce. Internalisation of *E.coli* and *L. monocytogenes* was found within core tissues and in the stomata of spinach and lettuce (Ölmez and Temur, 2010). *E. coli* O157:H7 was able to reach the internal cavity of stomata,

intercellular spaces of the spongy mesophyll and vascular tissue (Saldaña *et al.*, 2011). A number of factors influence the likelihood of internalisation of pathogenic bacteria within the plant such as strain/serotype of the bacteria, their concentration, plant type, route of contamination, age and stage of plant development (Deering *et al.*, 2012; Golberg *et al.*, 2011). Some bacteria strains are better able to colonise produce surfaces, damaged tissue, and form biofilms. Also the plant species influences the pathogen persistence (Olaimat and Holley, 2012). Several surface structures of enteric bacteria (pili, fimbriae, flagella and Type III secretion system) play an important role in bacterial adherence to produce (Shaw *et al.*, 2008). Some bacteria strains are better able to colonise produce surfaces, damaged tissue, and form biofilms. Also the plant species influences the pathogen persistence (Kroupitski *et al.*, 2009).

Although the overall population present on the plant's surface often declines after disinfectant washes such as chlorine or alternative sanitisers, enteric bacteria present inside the plant tissues are able to survive and replicate at high densities (Gu *et al.*, 2013). In addition, in most cases enteric bacteria survive in produce without modifying the habitat but start to aggregate to produce a biofilm matrix. Limitations in the effectiveness of most disinfectant washes are partly due to microbial biofilm formation and the physical structure of the produce which limits the accessibility of the sanitiser to reach sites where bacteria reside. Curli fibres which are known to be involved in cell aggregation and biofilm formation are also shown to play a role for internalisation of *S. enterica* in tomato and parsley (Cevallos-Cevallos *et al.*, 2012; Prigent-Combaret *et al.*, 2000). The occurrence of highly tolerant bacterial biofilms on food or food contact surfaces are known to contribute to food spoilage, cross contamination of food products and spread of food pathogens.

Several studies have reported increased resistance of enteric pathogens to a range of decontamination techniques like ultraviolet and pulsed light field due to internalisation and

extensive colonisation of produce stomata. Studies by Ziuzina *et al.*, (2015) demonstrated effective reduction of bacterial cells present on the surface of fresh produce using plasma while high concentration of cells were still noted intact in stomata wells. The study also revealed that applying temperature and light-dark conditions during produce distribution promoted bacteria internalisation and bacterial stress responses that could have significant impact on effectiveness of ACP or any decontamination techniques in fresh produce. Therefore, further studies are needed to assess the widespread internalisation of bacterial pathogens, their behaviour and mechanics of the interactions that could be used to control the contamination of fresh produce by pathogenic bacteria.

### **1.3.2 Bacterial Biofilm formation**

Many foodborne pathogens have been identified as biofilm producers on food and contact surfaces. Biofilms are ubiquitous in nature that can be found on almost every biotic and abiotic surfaces including stainless steel, polypropylene, wood, glass slides and food surfaces (Srey *et al.*, 2013). Bacterial biofilms are complex microbial multicellular communities embedded in an organised matrix mostly composed of extracellular polymeric substances (EPS) that traps other excreted cellular products including lysed cell debris and macromolecules. Although the extracellular polysaccharides provide basic structure to the biofilm matrix, a wide range of enzyme activity are found within the biofilms which affects the structure integrity and stability of the biofilm (Sutherland, 2001). Also non enzymatic protein lectins are found in the biofilm matrix that permits intergeneric aggregation that strengthens the matrix structure and constitute a link between the EPS and the bacterial surface (Kim and Wei, 2012).

Physiologically, bacteria in biofilms have different properties than planktonic or adherent cells of the same species. Differences in biofilm formation is also observed between the bacteria of same species with different strains and serovars. For example, biofilm formation

studies between five different *Salmonella enterica* serovars in Romaine lettuce and cabbage showed that *Salmonella Tennessee* and *S. Thompson* produced stronger biofilms compared to *S. Newport*, *S. Negev*, and *S. Braenderup* (Patel and Sharma, 2010). In another work, biofilm growth of *L. monocytogenes* strains Murray and 7163 was significantly higher than *L. monocytogenes* 23074 while *L. monocytogenes* 7148 (Chae and Schraft, 2000). It can be speculated that the biofilm forming capacity varies significantly between genera, species, strains and can be influenced by different stress conditions.

Biofilm formation is one of the universal ways in which microbial communities can develop coordinated structural and survival strategies. Biofilm are a self-protection growth pattern of bacteria, which are different from planktonic cells. They are of great importance for food hygiene since biofilms usually contain several pathogenic and spoilage bacteria which may possess a risk to post processing contamination and to public health. Biofilm formation occurs by cellular attachment of the substratum and formation of macro-colonies on the surface, producing extracellular substances (EPS) which assists the bacteria in attachment. The biofilm formation mechanism consists of different steps including (1) conditioning of the surface and reversible attachment of cells followed by proliferation and accumulation in multicellular cell clusters, (2) production of polysaccharides or capsules, and then formation of EPS resulting in irreversible cell attachment, (3) early development of biofilm matrix and (4) maturation and partial detachment of biofilm resulting in dispersal of biofilm cells over the surface (Hall-Stoodley *et al.*, 2004; Solomon *et al.*, 2005). Dispersal mechanisms helps to colonise new niches, repopulate surfaces following sub-lethal antimicrobial challenges. Biofilm provide an ideal niche for the exchange of extrachromosomal DNA. The mutation rate in biofilm cells are hundreds of times higher than in planktonic cells therefore increasing the chances of emergence and spread of resistance (Conibear *et al.*, 2009). When the bacteria are under stress they induce gene expression and are involved in protein synthesis so as to



combat the stress produced. Bacteria in a biofilm poses increased resistance to the host's immune system, antibiotics and environmental stress such as nutrition and oxidative stress, desiccation and UV light exposure (Fatemi and Frank, 1999). Their antibiotic resistance can be increased to a thousand times that of planktonic cells of the same species (Ciofu and Tolker-Nielsen, 2010). Therefore, biofilm associated infections often fail to respond to conventional antibiotic treatment that leads to high morbidity and mortality. Many mechanisms, responsible for rendering biofilm resistance against antimicrobial agents have been proposed: first is the dense or protective EPS making it difficult for the antimicrobial agents to penetrate into the biofilm matrix (Hall-Stoodley *et al.*, 2004). Further, nutrient and oxygen depletion within the biofilm renders them slow growing and metabolically inactive in which they are less susceptible to antimicrobial effect (Patel, 2005). The third mechanism includes the presence of a subpopulation that might exhibit a phenotypical resistant state. Overall the mechanism of resistance of the biofilm against antimicrobial agents seems to be affected by factors including the environmental stress, enzyme production, cell internalisation and the organism involved (Lindsay and von Holy, 2006; Patel, 2005).

Bacterial biofilms are an important concern in the food industry which are suggested as potential sources of contamination during processing and distribution (Dufour *et al.*, 2004). In particular, bacterial biofilm formation on food surfaces and in food processing units (equipment, water distribution system) contributes to food spoilage or cross contamination of food products. The ability of the foodborne pathogens to form biofilms have been previously reported. *L. monocytogenes*, *Pseudomonas* spp., *Bacillus* spp., *Salmonella* spp. are the most common biofilm-forming bacteria isolated from food processing environments (Blaschek *et al.*, 2007). Bacterial biofilm formation on food surfaces has become an important public health concern with their acquisition of increased antimicrobial resistance. Although efforts have been made to reduce bacterial contamination in food products the incidences of

foodborne illness are increasing. Therefore, better understanding of biofilms, types of EPS and quorum sensing will be beneficial for the development of efficient technologies to control the biofilm formation in food products and food processing environments.

### **1.3.3 Mixed culture biofilm formation**

In nature, most of biofilms are composed of multispecies both in biotic and abiotic environments (Tan *et al.*, 2017). This multispecies biofilms may belong to different strains of the same bacteria or multi-bacterial species (Sztajer *et al.*, 2014). Mixed culture biofilms have been widely distributed in the natural and industrial environments. The formation of mixed culture biofilms on food and fresh produce depends on several factors including the microbial species involved, species composition, food type, nutrients, quorum sensing, biofilm maturation and EPS production. Mixed culture biofilms have gained attention in the recent years due their ability to resist higher antimicrobial challenges compared to single species biofilms (Lohse *et al.*, 2017; Pang *et al.*, 2017; Parijs and Steenackers, 2018). A growing number of studies have reported an increasing cross resistance between different types of antimicrobials (Davin-Regli and Pagès, 2012). Several factors could be involved for the tolerance of multispecies biofilms which include the higher extracellular polymer substance (EPS) production, differences in physiological status depending on biofilm stratum, interspecies cross protection among the species and internalisation into the food (Stewart, 2015). For example, in the meat processing industry several bacterial strains like *Acinetobacter calcoaceticus* and *Pantoea agglomerans* were characterised to promote weak or non-biofilm formers to attach to solid surfaces and consequently form biofilms (Habimana *et al.*, 2010). Although, the exact mechanism responsible for the higher tolerance of multispecies biofilm is still a matter of debate among studies.

Multiple studies have demonstrated a diverse variety of microorganisms in fresh produce, including soil bacteria (*Pseudomonas fluorescens*, *Erwinia carotovora* and *Rahnella*

*aquatilis*), plant related bacteria, coliforms and opportunistic plant-human pathogens (Liu *et al.*, 2013). Bacterial strains unable to form single-strain biofilms could acquire additional protective mechanisms and form a stronger biofilm when they come in contact with the strong biofilm formers. It has been noted that the biofilm forming capacity of the *Burkholderia caryophylli* was enhanced by interacting with *E. coli* (Liu *et al.*, 2014). Given the diversity of biofilms, the interspecies relations play an important role in determining the function, structure of these biofilms, and these interspecies are unpredictable from the studies of mono-species biofilms.

So far little has been reported on the application of ACP for etching of complex biological systems such as mixed culture bacterial biofilms. Abramzon *et al.*, (2006) and Alkawareek *et al.*, (2012) reported biphasic inactivation of bacterial mono-species biofilms by cold atmospheric pressure plasma exposure. Rapid cell decline was observed during the first phase (initial 60s) of plasma exposure, with D-value of 23.57s. After 60s of plasma exposure, a slower second phase with lower bacterial reduction and a higher D-value 128.20s was recorded. However, the interaction mechanism between the plasma and biomolecules are not fully understood. New insights into the regulation of mixed biofilm formations in the food industry are required. Food preservation conditions are adverse for the bacteria which might induce stress responses and enhance biofilm formation (Chen *et al.*, 2017; Vivijs *et al.*, 2016). There is a demand for appropriate techniques to be applied to develop further understanding about the interaction and ultimate elimination of multispecies biofilms. This study therefore focuses on understanding the mechanism and control measures of multispecies biofilm by ACP treatment.

#### **1.3.4 Quorum sensing (QS)**

Quorum sensing (QS) is a mechanism of cell to cell communication in bacteria that relies on the production and detection of signal molecules called auto-inducers that modulate gene

expression in cell density dependent manner (Medina-Martínez and Santana, 2012). Auto-inducers help monitor cell density. They are produced in response to accumulation of bacterial cells to a threshold limit. Once inducers reach a critical concentration, it modulates the expression of genes involved in a variety of physiological processes including symbiosis, bioluminescence, swarming, motility, virulence, biofilm formation, sporulation, plasmid conjugal transfer, toxins, antibiotic production (Galloway *et al.*, 2011; Rutherford and Bassler, 2012; Waters *et al.*, 2008). The identity of auto-inducers in bacteria is distinct between Gram positive and Gram negative organisms. Gram positive bacteria like *Staphylococcus aureus*, synthesise and respond to polypeptides or auto-inducer peptides (AIPs) and they are processed during secretion through the ATP binding cassette (Monnet and Gardan, 2015). Gram negative bacteria are the most intensively investigated with respect to quorum sensing; bacteria communicate using acyl homoserine lactones (AHL's) as a primary signal molecule. The synthesis of AHL signalling pathway in Gram negative bacteria depends on three main components: a gene coding for the enzyme-synthase responsible for generation of AHL signalling molecules (Lux-I gene and its homologues), the signalling molecule itself and an intracellular cytosolic receptor (Lux-R) which is a transcription activator of the genes regulated by QS (Rutherford and Bassler, 2012).

*Pseudomonas aeruginosa* AHL dependent QS are well characterised and provide a relevant example of QS sensing in pathogenic bacteria. *P. aeruginosa* harbour three QS systems: two LuxI/LuxR-type QS circuits that function in series to control the expression of virulence factors as well as a third, 2-alkyl-4-quinoloneregulated system also called the *Pseudomonas* quinolone signal (PQS) system. The hierarchal system helps control *P. aeruginosa* QS-activated virulence factors such as elastases, proteases, pyoverdine, pyocyanin, rhamnolipids and toxins (Pearson *et al.*, 1997; Rutherford and Bassler, 2012).

Biofilms are well organised, complex microbial communities that are present ubiquitously and able to attach to several surfaces including food surfaces. The role of QS in bacterial formation is well known. Zhu *et al.* (2003) demonstrated that QS participates in the biofilm differentiation process. A comparison of biofilm production in two strains, the wild type and the quorum sensing deficient mutant of *V. cholera* was investigated. The mutant strain demonstrated a thicker biofilm than those formed by the wild-type bacteria. Biofilm formation the associated resistance to antimicrobials and sanitisers is a persistent problem in the food processing industries. Since QS plays an important role in biofilm formation, several studies have focused on QS as a target mechanism to inhibit and control the foodborne pathogens and their biofilms from the food surface. Thus, inhibiting QS may impact biofilm formation and retard spoilage. The potential involvement of QS in the regulation of bacterial biofilms by foodborne pathogens on food surfaces could be a potential new mechanism in an effort to mitigate pathogens from persisting in surface attached communities.

### **1.3.5 Microbial spore formation**

Spore forming bacteria play an important role in food spoilage and associated with foodborne illness. The presence of spores poses a major challenge in the food industry, which are actively involved in employing strategies to ensure complete inactivation of spores and control their outgrowth. Bacterial spores are dormant and extremely resistant to a variety of disinfection agents such as heating, desiccation, enzymes and toxic chemicals. Three main spore forming bacteria species are *Bacillus cereus*, *Clostridium perfringens*, *Clostridium botulinum* (Wells-Bennik *et al.*, 2016). The harmful effects concerning food safety and quality caused by these spore formers are majorly from the production of toxins and spoilage enzymes which are responsible for foodborne illnesses including food poisoning.

Spores are structurally, biochemically and physiological different from vegetative cells. Spore-formers have extraordinary tendency to enter sporulation as an adaptive strategy to

survive conditions encountered in natural habitats transforming them into metabolic dormant endospores (Al-Hinai *et al.*, 2015; Markland *et al.*, 2013). Dormant spores are resistant to environmental stresses for instance heat, salinity, pH, water or nutrient availability. They are composed of an exosporangium, coat, outer membrane, cortex, cell wall, inner membrane and core (Wells-Bennik *et al.*, 2016). There are number of reasons involved in their long term survival and their resistance to extreme conditions including; (i) spore coats that restricts access of chemical toxic agents to enter sensitive targets located within the spore; (ii) low level of water in spore core region, spore core dehydration; and (iii) protection of spore DNA by its saturation with small acid-soluble proteins (SASP) (Setlow, 2007). The main reason for a spore's metabolic dormancy is its low water content and its extremely low permeability to hydrophilic small molecules. Clearly this challenges the fact that spore formers show enormous diversity with respect to different types of spore resistance properties, its growth and characteristics acquired at different times of sporulation. Despite their dormancy, spores can still sense environmental changes. Ideal conditions (e.g. nutrient availability) triggers the germination process in spores transforming them to vegetative states (Setlow and Johnson, 2013). With the abundance of spores along with the distinct characteristics of spore resistance are responsible for product defects and spoilage of food products leading to economic losses and substantial food wastes (Wells-Bennik *et al.*, 2016). The resistance properties of the spore vary between species and strains present in the food chain, in addition, environmental conditions during spore formation and maturation also contribute to variation.

### **1.3.6 Microbial stress responses and adaptations**

Over the past few decades, bacteria have evolved enormously in regards to their adaptive network to face challenges of their changing environments and stress conditions (Abee and Wouters, 1999). Stress responses are of particular importance in bacteria as they are constantly exposed to various chemical, biological and physical changes in their

environment. On exposure to stress conditions, bacterial cells may lose their viability, get injured or express adaptive mechanisms that would help the bacteria to survive and continue to grow during stress conditions.

Foodborne microorganisms encounter a variety of stresses at every step of the food chain, including production, harvest, postharvest handling, processing, disinfection and storage. Environmental stresses such as acid, oxidative, cold or heat shock induced mutations are reported to increase the tolerance or resistance of bacteria. Depending on the magnitude of the stress involved, stress can be differentiated as sub-lethal or lethal stress. Lethal stresses are severe, they cause irreversible damage to the microbial cells and often lead to cell death. When microorganisms are exposed to sub-lethal stresses, it can cause metabolic changes and induce adaptation to subsequent levels of same stress or at times to different stress condition (Hill *et al.*, 2002). Microbial adaptation to stress are also known to extend the tolerance to multiple other lethal stresses which are referred to as cross protection (Johnson, 2002). Microorganism utilise cross-protection as a defence mechanism against food disinfection or food preservation techniques (Rodriguez-Romo and Yousef, 2005). Understanding how pathogens sense stress and respond to stress is important in order to design safe and effective minimal processing regimes.

### **Stress responses of *L. monocytogenes***

*L. monocytogenes* is a persistent strain commonly associated with multiple foodborne outbreaks globally. The key feature contributing to *L. monocytogenes* ability to thrive under varied conditions is its adaptability. *L. monocytogenes* possess adaptive responses to several physiological stresses such as acid, heat, salt, alkali and oxidative that these cells are likely to be exposed in the food processing environments. In *L. monocytogenes*, the Sigma factor B ( $\sigma^B$ ) has been shown to play a role in its growth and survival under several stress conditions (Wiedmann *et al.*, 1998).  $\sigma^B$  of *L. monocytogenes* is responsible to regulate the

expression of numerous genes under environmental stress conditions. Sigma factor in association with core RNA polymerase provides a mechanism for cellular responses that are mediated through redirection of transcription initiation (Kazmierczak *et al.*, 2005). The *L. monocytogenes*  $\sigma^B$  regulon includes more than 150 genes that are both directly and positively regulated by  $\sigma^B$  (Abram *et al.*, 2008) including genes encoding proteins responsible for stress response, virulence (*prfA*, *bsh*, *inlA*, and *inlB*), damage repair, carbohydrate metabolism, and transport (Raengpradub *et al.*, 2008; Toledo-Arana *et al.*, 2009). Not only is  $\sigma^B$  a core regulator, guiding transcription of several other regulators but there is also considerable transcriptional cross talk between sigma factor and other regulators, highlighting its central role in adaptation.  $\sigma^B$  contributes to the bacterium's growth and survival in the presence of stress agents employed. Furthermore,  $\sigma^B$  has been demonstrated to contribute to the ability of stationary-phase *L. monocytogenes* cells to adapt and resume growth after exposure to sub-lethal stress conditions (Ferreira *et al.*, 2001). These exposures to sub-lethal stress may lead to enhanced survival, resistance, virulence and even cross protection against multiple stresses.



**Table 1.5: Factors identified to have an impact on the growth and survival of *L. monocytogenes* (adapted from Commission of the European Communities, 2008).**

Factors	Growth			Survival
	Lower growth limit	Optimum	Upper growth Limit	
Temperature (°C)	-1.5 to +3.0	30.0 to 37.0	45.0	-18.0
pH	4.2 to 4.3	7.0	9.4 to 9.5	3.3 to 4.2
Water Activity (a <sub>w</sub> )	0.90 to 0.93	0.99	> 0.99	< 0.90
Salt concentration (%)	< 0.5	0.7	12 – 16	≥20
Atmosphere	Facultative anaerobe (it can grow in the presence or absence of oxygen; e.g. in a vacuum or modified atmosphere package)			

The limits for growth and survival of *L. monocytogenes* presented in this table are based on research carried out primarily in laboratory media under optimum conditions hence provides a rough estimate.

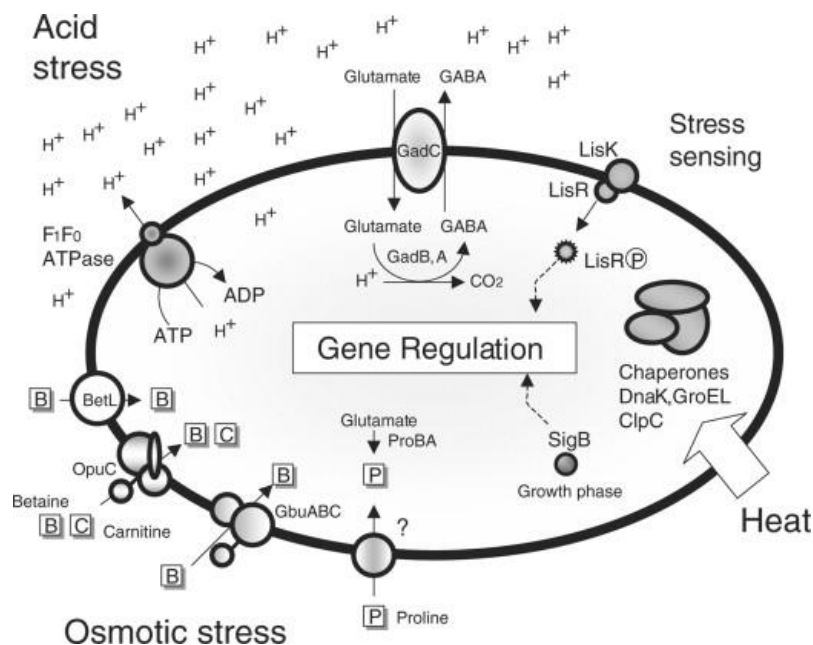

**Figure 1.1: A representation of the systems and their proposed roles in stress protection/adaptation in *L. monocytogenes* (Hill *et al.*, 2002).**

## Acid stress

*L. monocytogenes* is subjected to low-pH conditions in a range of environments including: acidic foods or acid preserved foods, food processing environments, gastric passage in host and in host cell vacuoles (Cotter and Hill, 2003). The bacterium has been shown to survive acid conditions as low as pH 2.5 (Davis *et al.*, 1996). There are a number of different systems within *L. monocytogenes* that contribute to its acid tolerance including, the glutamate decarboxylase (GAD) system, the arginine deiminase system, and the adaptive acid tolerance response system (ATR) (Cotter *et al.*, 2001; Davis *et al.*, 1996; Ryan *et al.*, 2009).  $\sigma^B$  plays an important role in ATR of *L. monocytogenes* induced by exposure to mild acidic pH conferring protection against extreme pH conditions. These ATR's are also identified to provide cross protection against osmotic and thermal stresses which have roles in food preservation. Acid adapted populations were found to be more tolerant to other stress or disinfectants than their non-adapted counterparts (Gahan *et al.*, 1996). Acid-adapted *L. monocytogenes* (pH 5.5, 2 h) had increased resistance and survival against heat shock (52 °C), osmotic shock (25–30% NaCl) and alcohol stress (15%) (Koutsoumanis *et al.*, 2003).

*L. monocytogenes* utilise glutamate decarboxylase (GAD) system to maintain pH homeostasis and survive under acid conditions. Depending on the strain, *L. monocytogenes* possesses three decarboxylase genes (*gadD1*, D2 & D3) and two antiporter genes (*gadT1* & *gadT2*). The GAD system involves combined action of a membrane bound antiporter (GadT) and a cytosolic glutamate decarboxylase (*GadD*). When the bacterium is exposed to low pH, GAD system decarboxylates glutamate to  $\gamma$ -aminobutyrate (GABA). In this process, bacterium exchanges extracellular molecule of glutamate with intracellular molecules of  $\gamma$ -aminobutyrate via antiporter (Feehily *et al.*, 2014). Expression of several genes involved in GAD system are under  $\sigma^B$  regulation which however has been shown to vary amongst strains (Kazmierczak *et al.*, 2003). Deletion of the *sigB* gene resulted in the elimination of acid

induced transcription of *gadD2*, *gadT2* and *gadD3*, highlighting the role of  $\sigma^B$  in acid adaptation (Wemekamp-Kamphuis *et al.*, 2004). In addition, *L. monocytogenes* also possesses an arginine deaminase (ADI) pathway and  $\sigma^B$  depended agmatine (AgDI) deiminase system. The ADI system operates through the catabolism of arginine to produce ornithine and ammonium ions ( $\text{NH}_4^+$ ) which interacts with cytoplasmic ions to raise the intracellular pH and protect from cell damage (Gahan and Hill, 2014).

### **Cold stress**

Cold stress tolerance is one of the fundamental attributes of *L. monocytogenes* that contributes to the microbe's persistence during refrigeration conditions. This phenomenon renders the use of low temperature during food processing and long-term storage of food products under refrigeration temperature ineffective against *L. monocytogenes*.

*L. monocytogenes* produces cold shock proteins (Csps) in response to temperature downshock and cold acclimation proteins (Caps) are synthesised during balanced growth at low temperatures (Beales, 2004). The Csps consists of small highly conserved and structurally related nucleic acid groups that are presumably responsible for regulation of various microbial physiological processes. Schmid *et al.* (2009) demonstrated the roles of Csp in the cold and osmotic (NaCl) stress adaptation responses in *L. monocytogenes*. The fact that Csp promotes the microbial adaptation against cold and osmotic conditions has significant implications in food microbial control measures; the combined or sequential exposure of *L. monocytogenes* to these two stresses in food processing environment might inadvertently induce cross protection responses. Although several transcriptomic analyses has revealed the activation of *L. monocytogenes* genes during cold stress, however the precise role involved in cold adaptation is still not understood (Chan *et al.*, 2007). Differential expression of cold adaptation genes were observed in *L. monocytogenes* strains which resulted in differences in

cold tolerance (Arguedas-Villa *et al.*, 2010). The loss of Csp proteins abolished cold growth of *L. monocytogenes* organisms at refrigeration temperatures (Schmid *et al.*, 2009).

In the view of food safety, it is important to understand how these organisms are able to adapt their cellular physiology and overcome several food processing related stresses and resist current control measures. Minimally processed food is easily contaminated by foodborne pathogens either directly or indirectly by cross-contamination in food processing environment. It is increasingly clear that many of these foodborne pathogens have acquired multiple complex mechanisms to withstand a wide range of environmental stresses. Apart from enhanced survival and resistance to food processing treatment, these adapted pathogens have also enhanced virulence through cross resistance. Therefore, further research using cumulative sub-lethal damages and safe practical interventions without inducing stress responses is needed for safe decontamination of fresh produces with a particular emphasis required on emerging non-thermal process technologies that may rely on a hurdle approach to maintain a safe shelf life.

#### **1.4 Current Decontamination technologies**

Decontamination is one of the most critical steps in food processing affecting quality, safety and shelf life of the product. In order to obtain a maximum nutritional benefit at the point of consumption, fruits and vegetables are typically eaten raw or minimally processed. As minimally processing does not include intensive preservation or formal treatment steps in the production line such as heat sterilisation, freezing or drying, they often do not effectively reduce pathogenic bacteria, their spores or biofilms from the food produces. In response to consumer's health concerns, researchers have investigated the efficiency of several physical, chemical and biological methods to efficiently eliminate microbial loads from food surfaces while ensuring safety, nutritional and food quality along with an extension of shelf life. Decontamination steps that could be employed for minimally processed fruits or vegetables

include the use of disinfectants (chlorine, hydrogen peroxide, organic acids), chemical preservation (ascorbic acids and calcium salts), bio-preservatives, mild heat treatment, high intensity electric field pulses, ultraviolet radiation (UV) and ozone. Most of the conventional methods used for fresh produce which provide effective results they are expensive, time consuming or have detrimental effects on the overall quality of the product. The principle fresh produce and wastewater decontamination techniques in food industry are summarised below:

#### **1.4.1 Chlorine**

Chlorine and chlorine derivatives have been the most common and widely used sanitiser in the agricultural and food industry for several decades (Rangel-Marrón and López-Malo, 2012). Chlorine has antimicrobial action known to inhibit a broad range of microorganisms in food products and water (Chaidez *et al.*, 2012; Temiz *et al.*, 2011). The inactivation mechanism of chlorine is: interference with cell associated membrane function, phosphorylation of high energy compounds, altered permeability of outer membrane resulting leakage of cell components, breakage into DNA, depress DNA synthesis, inhibitions of protein/enzyme synthesis, oxidation of respiratory components, irreversible oxidation of sulfhydryl (Dodd, 2012; Dychdala, 2001). The inhibitory activity or lethal effect of chlorine disinfection depends on the concentration applied and the contact time (Gil *et al.*, 2016). However, excess or higher concentration usage of chlorine can result in toxic residues and by-products such as halogenated trichloromethanes (TAMs) and haloacetic acids (HAAs) which have created major health hazard and increased the risks for public health (Gopal *et al.*, 2007; Van Haute *et al.*, 2013). Based on the current decontamination practices in the food industry, an EFSA panel on Contaminants in the Food Chain concluded that the application of a hypothetical maximum residue limit (MRL) of 0.7 mg/kg for all foodstuffs and drinking water that would only minimally reduce acute/chronic exposures and related risks (EFSA, 2015b).

The efficacy of chlorine treatment depends on the growth of microorganisms during storage and any development of bacterial biofilms (Joseph *et al.*, 2001; Villagómez *et al.*, 2010), surface properties of the product like the shape and size of the fruits or vegetables (Yuk *et al.*, 2006) and the amount of organic matter released from soil or fresh produce washes etc.

#### **1.4.2 Ultrasound**

Ultrasound is generally defined as a series of sound waves generated at high frequency which is near the upper limit of the human ear (Elmehdi *et al.*, 2003). The lethal effect of ultrasound has been known for several decades. Ultrasound is classified into two major categories based on their frequency range: Low intensity ultrasound frequency range of 5-10 MHz and High intensity ultrasound with frequency range of 20-100 MHz (McClements, 1995). High power ultrasound at lower intensity is also known as power ultrasound, it has been recognised as a promising tool for the treatment of liquids in the food industry. High power ultrasound is capable of inactivating microorganism and enzymes (Sinisterra, 1992). Ultrasound treatment could be applied in a variety of ways, compressional and shear waves are most commonly used in the food industry (McClements, 1997). Although other forms of ultrasound like surface waves could also be useful for biotechnological applications.

Microbial inactivation by ultrasound occurs by production of acoustic cavitation which causes disruption, localised heating and free radical formation (Patil *et al.*, 2009). This action breaks the living cells, damages the cell wall, cell membrane and cell organelles that eventually results in cell death or sub-lethal injury (Cameron *et al.*, 2008). Cavitation is the formation, expansion and implosion of gas bubbles inside the liquid as the molecule absorbs ultrasound energy. Several factors influence the inactivation efficiency of ultrasound that include: temperature and viscosity of treatment liquid, frequency of ultrasound, characteristics of food and target bacterial cells (Moncada *et al.*, 2012; Sala *et al.*, 1995). The effect of ultrasound on several microorganisms have been studied, reports have indicated

Gram positive bacteria being more resistant to ultrasound treatment than Gram negative bacteria (Drakopoulou *et al.*, 2009; Monsen *et al.*, 2009). Conversely, other studies have reported no significant difference in the inactivation process (Scherba *et al.*, 1991). The interaction between the ultrasound and microorganisms at sub-lethal/recovery stage is a complex process and is not completely understood.

As for food quality aspects, high intensity ultrasound is generally non-destructive, rapid technique that maintains the flavour of the food, maintains homogeneity and preserves firmness (Cao *et al.*, 2010; Sagong *et al.*, 2011). Although, high intensity application uses power levels that are high as 10-1000W/cm<sup>2</sup> they could affect properties of the food, often permanently. Ultrasound has certain desirable and few detrimental effects on nutritional and quality of food. However, authors have recommended using ultrasound in combination other disinfection techniques (Seymour *et al.*, 2002; Zhu and Mekalanos, 2003).

#### **1.4.3 Ultraviolet (UV) radiation**

UV is radiation with wavelengths between visible light and X-rays of the electromagnetic spectrum. UV light is divided into UVA (400-320 nm), UVB (320-280 nm), UVC (280-200 nm) and vacuum UV (VUV) (200-100 nm). The inactivation of microorganisms by UV radiation is directly dependent on the intensity, duration and dose of UV radiation. The UV dose is typically expressed in units of mJ/cm<sup>2</sup> or J/m<sup>2</sup> (where mJ/cm<sup>2</sup> = 10J/m<sup>2</sup> and is function of UV intensity, mW/cm<sup>2</sup> and exposure time, s).

UV inactivates microorganisms by their absorption light. This causes photochemical reactions that damages molecular components of bacteria and directly impact the genetic material (DNA) within the cells (Chen *et al.*, 2006). The germicidal effect of the microorganisms is primarily due to formation of thymine dimmer affecting the normal replication of the genetic code within the cell (Mukhopadhyay *et al.*, 2014). The growth and reproduction of the bacteria are thus lost, being no longer threat to human health. The major

DNA damage occurs from irradiation at wavelengths within the UV-C wavelength (280-200 nm) and with a maximum adsorption at 265 nm (Kiefer, 2007). This wavelength is commonly used for UV disinfection systems, validated for inactivation of major waterborne pathogens. UV light can be produced by a variety of UV lamps however; mercury and electric arc lamps are the most common which provide continuous sources of UV light. The light output from the lamp depends on the mercury pressure within the lamp. UV disinfection uses either low pressure mercury lamp at a wavelength of 253.7 nm or medium pressure mercury lamps from 200 to 600 nm (Gayán *et al.*, 2014). Light at this wavelength does not have enough energy to ionise atoms or molecules therefore the UV treatment is classified as non-ionization radiation. Besides pathogen inactivation, UV can oxidise simple organic compounds like carbon attached to other key elements such as nitrogen, hydrogen, phosphorus which are the foundation of complex compounds such proteins, amino acids and peptides. However, UV radiation is innocuous against complex compounds present in water such as pesticides, suspended solids or volatile organic compounds since they require higher energy to degrade. Due to poor penetrability, there is considerable energy usage and interference of the chemical constituents of the wastewater with the lamps, therefore several approaches combine UV with other methods or auxiliary compounds in order to produce more powerful and effective results.

#### **1.4.4 Ozone**

Ozone is a strong oxidant and an antimicrobial agent. It is a pale blue gas consisting of loosely three oxygen atoms that is readily available to attach to and oxidise other molecules. It has oxidation reduction potential greater than chlorine, hydrogen peroxide and hypochlorous acids that conveys it antimicrobial properties (Kim *et al.*, 1999). Ozone is broad-spectrum antimicrobial agent active against a wide range of microorganisms including bacteria, fungi, virus, bacterial and fungal spores (Burleson *et al.*, 1975; Guzel-Seydim *et al.*,



2004; Khadre *et al.*, 2001). Commercial levels of ozone are commonly generated by either high energy electric field corona discharge system or by photochemical UV radiation. In addition to the above methods, ozone can be generated by chemical, thermal, chemonuclear or by electrolytic methods in ambient air (Tapp and Rice, 2012). They are cost effective methods and can be applied either in gaseous or aqueous phases.

The antimicrobial mechanism of ozone is a complex process that acts by: direct contact by ozone molecule being dominant at low pH or indirectly by action of ozone generated free radicals at high pH (Zuma *et al.*, 2009). Ozone decomposition in water causes the generation of several free radicals like hydroperoxyl, hydroxyl and super-oxides. The main locus of action is the cell wall and the cell membrane, where ozone acts by oxidation of unsaturated lipids, free fatty acids and protein components (Scott and Lesher, 1963). Damage to the cell causes penetration of ozone and free radicals into the cell thus reacting with intracellular components (DNA, RNA, enzymes) which results in cell lysis or cell death (Guzel-Seydim *et al.*, 2004; Scott and Lesher, 1963). Several studies have demonstrated the effectiveness of ozone treatment against a wide range of microorganism in food products (Kim *et al.*, 1999; Ölmez and Temur, 2010; Yuk *et al.*, 2006). However, the efficacy of ozone for food processing applications has been demonstrated to be influenced by many factors such as the treatment product, relative humidity, pH value, treatment temperature, target microorganism, type of ozone treatment, stability and concentration of ozone (Cullen and Norton, 2012). Therefore, food scientists are focused on development of new efficient technology which would provide microbiologically safe product with longer shelf life while maintaining fresh like characteristics and high food quality.

## 1.5 Atmospheric cold plasma (ACP)

### 1.5.1 Plasma and its classification

Plasma is a quasi-neutral ionised gas and is referred to as fourth state of matter. It is composed of free electrons, UV photons, charged particles (positive and negative ions), molecules that are in the ground and excited states, and a wide range of reactive species such as hydrogen peroxides and nitric oxide derived species (Guo *et al.*, 2015). Plasma is an electrically energised gas generated by progressive application of energy to a matter that converts solid to liquid up to gas phase. Further application of energy ionizes the gas molecules resulting in plasma state. Depending on thermodynamic temperature equilibrium of the constituents (Bogaerts *et al.*, 2002), plasma can be classified into two major categories: thermal and non-thermal plasma (Fridman *et al.*, 2008).

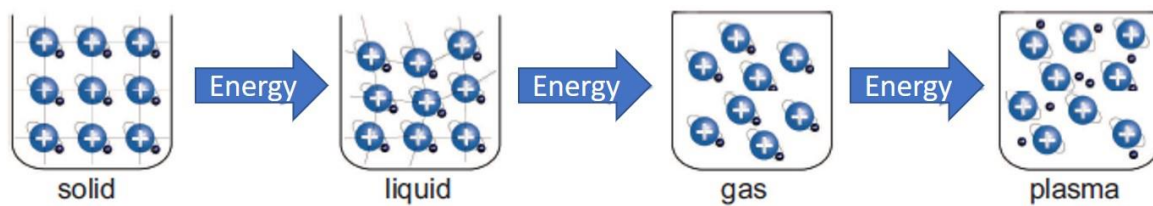

**Figure 1.2: The transition of states of matter on application of energy.**

Thermal plasma involves the introduction of high energy, pressure and thermal conductivity to maintain the plasma constituents in thermal equilibrium (Tendero *et al.*, 2006). They are characterised by the high temperature of the electrons and heavy species of plasma, which reaches several thousand Kelvins. While, non-thermal plasma is generated by electric discharge in a gas at atmospheric or reduced pressure and requires less power (Misra *et al.*, 2011). It is characterised by non-equilibrium, where cooling of the ions and the uncharged molecules is significantly more effective than that of energy transfer from electrons resulting in the gas remaining at a low temperature (Bourke *et al.*, 2017). It has a non-uniform distribution of energy among the constituent particles (Niemira, 2012). As a practical matter,

non-thermal plasma can cause little or no thermal damage to heat sensitive products. Therefore, non-thermal plasma is also referred to as cold plasma (Noriega *et al.*, 2011a), cool plasma (Tran *et al.*, 2008) and other comparable terms which have been used in recent publications. Plasma can be generated using different gases such as air, nitrogen, oxygen or mixture of different proportion of noble gases such as helium, argon or neon. Plasma sources operating at atmospheric air and pressure are a focus of interest due to the economical and operational advantages for industrial applications.

Cold plasma treatment is capable of surface sterilisation and activation through physical, chemical or physical/chemical mechanisms without changing the properties of the substrate material. To generate ACP, a range of discharge systems have been developed which include radio-frequency plasma, corona discharge, dielectric barrier discharge plasma, Gliding arc plasma and glow discharge (Kogelschatz, 2004; Morent and De, 2011). These types of gas discharge systems provide room temperature conditions, flexibility of different geometric shapes of experimental arrangements and for scaling up to large dimensions.

### **1.5.2 Types of ACP system**

Some of the widely used plasma sources for food applications are dielectric barrier discharges (DBD), plasma jets and corona discharges.

#### **1.5.2.1 Corona discharge system**

Corona discharges are localised luminous discharges generated in the neighbourhood of a pin or thin wire at low atmospheric pressure. They are non-uniform discharge that generate a high field region near a sharp electrode spreading towards a planar ground electrode. The corona is generated by a strong electric field associated with a small diameter wire, needle, sharp edge towards the electrode (Chang *et al.*, 1991). Ionization and emission of the plasma therefore occurs locally around the pin or the wire. This type of discharge is characteristic of asymmetric electrode pair and results from an electric field that surrounds an inhomogeneous

electrode arrangement powered by continuous or pulsed DC voltage. This phenomenon of the discharge breakdown and forming lighting crown of plasma around the wire is known as corona discharge (Tendero *et al.*, 2006).

### **1.5.2.2 Atmospheric pressure plasma jet**

Numerous different types of plasma jets have been studied and developed. These plasma jets differ with various design configurations, size, gas, frequency and applied voltage. Atmospheric pressure plasma jet produces a stable, homogenous and uniform discharge at atmospheric pressure. The general plasma jet consists of a gas channel made of one or two electrodes between which the working gas flows through the jet's nozzle into ambient air. Working gases used are noble gases like helium, argon, mixture of other gases or atmospheric air. When a sufficiently strong electric current is applied, plasma is generated that expands out the jet's nozzle via gas flow. The distance between the electrodes is within the range of millimetres while the exposure distance between the nozzle of the jet and the treatment sample is in centimetre range. The reactive components generated such as excited atoms, free radicals, charged particles, reactive species etc. are released from the plasma jet at high velocity which quickly react with the target. Atmospheric plasma jets have been shown to inactivate many different microorganisms as well as their spores and biofilms (Hu *et al.*, 2018; Lu *et al.*, 2018). Due to their small size and moderate temperature they are widely used for biomedical applications like dentistry, wound healing, blood coagulation and surface sterilisation but they could be employed for large scale application by moving the jet or by applying multiple nozzles (Daeschlein *et al.*, 2010; Morent and De, 2011; Perni *et al.*, 2008).

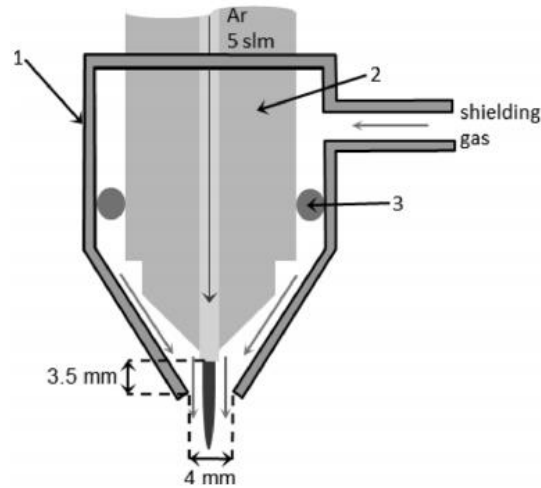

**Figure 1.3: Schematic setup of Plasma Jet (Reuter *et al.*, 2012).**

1: Polymer, 2: Plasma jet 3: Centering O-ring

### 1.5.2.3 Di-electric Barrier Discharge (DBD) plasma system

Di-electric discharge plasma also known as silent discharge is a specific type of AC discharge that provides strong thermodynamic non-equilibrium plasma at atmospheric pressure and at moderate gas temperature (Chirokov *et al.*, 2005). The DBD plasma system is characterised based on the use of at least one di-electric layer (insulator) between discharge gap for initiation of the plasma discharge. The discharge gap itself could be of different widths, depending on its application. The di-electric barrier could be made of glass beads, ceramic, thin enamel, polymer or dielectric capillary layers (Kogelschatz, 2003). The di-electric barrier prevents building up of high current, spark formation, eliminates electrode etching, corrosion and distributes the discharge uniformly thus providing a homogenous treatment (Tendero *et al.*, 2006). DBD operates strongly under non-equilibrium conditions at atmospheric pressure for different gases including air at high power levels. The properties and amount of plasma generation depends on the working gas composition, distance between the electrodes, applied voltage and frequency (Kogelschatz, 2002). The high voltage level ionizes the gas within the

electric field thus creating significant amount of reactive molecules within the discharge gaps (Misra *et al.*, 2011).

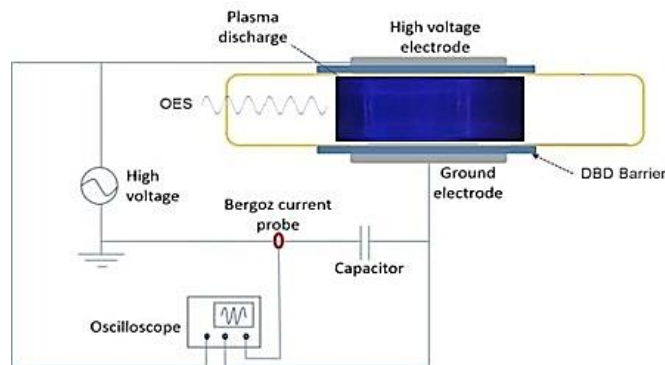

**Figure 1.4: Schematic principle of Dielectric Barrier discharge (DBD)**

DBDs are a widely used plasma discharge system (Kogelschatz, 2003; Wagner *et al.*, 2003). It has been employed for sterilisation of various bacteria and large surfaces thus offering an important advantage for large scale industrial applications. The design of DBD plasma system could be modified depending on the potential application of the plasma system and for scaling up to large dimensions. They have a large number of industrial applications as the system operates in strong non-equilibrium state at atmospheric pressure and at reasonable high power without using sophisticated power supplies (Fridman *et al.*, 2005).

### 1.5.3 Mechanism of decontamination by ACP

The mechanism of microbial inactivation by cold plasma is a complex process. Atmospheric cold plasma exposure generates several reactive plasma components such as reactive oxygen species (ROS), reactive nitrogen species (RNS), ultraviolet (UV) radiations, charged particles and metastables. Cold plasma can trigger complex biochemical processes resulting in physical and chemical modifications of biological matter. The exact mechanism underlying bactericidal inactivation by ACP treatment are target and system dependent, but studies have demonstrated plasma components like charged particles and generated reactive species

generally play an important function in the bacterial inactivation process (Timoshkin *et al.*, 2012). Plasma's antimicrobial effect is likely due the synergistic action of reactive species generated by the plasma system.

Depending on the working gas employed, various categories and amounts of chemically reactive species are produced by ACP (Han *et al.*, 2014; Zhang *et al.*, 2013). Primarily, Reactive Oxygen Species (ROS) and Reactive Nitrogen Species (RNS) generated by plasma make a significant contribution to the inactivation of microorganisms. ROS and RNS have a strong oxidative effect on cell structures. Among the several ROS produced, hydrogen peroxide ( $H_2O_2$ ), hydroxyl ions ( $OH^\bullet$ ), ozone ( $O_3$ ) chemical species are considered as potent antimicrobial agents (Alkawareek *et al.*, 2012). Diffusion of reactive oxygen species through the cell membrane is known to cause oxidative damage to cytoplasmic membrane, proteins, lipids and DNA. Studies by Lee *et al.* (2012) found that DBD plasma with He/ $O_2$  input gas resulted in higher inactivation on cheese slices than treated with He alone. The addition of oxygen helped to produce more oxygen-based radicals (e.g.  $OH$ ,  $O_2^-$ ,  $O_3$  etc.) leading to stronger antimicrobial effects. The  $OH^\bullet$  radicals initiates lipid peroxidation by subtracting H radicals from unsaturated carbon bonds of fatty acids which leads formation of methylenedianiline (MDA) and 4-hydroxynonenal (4-HNE) as end products. MDA and 4-HNE are used as a marker for lipid peroxidation, where the presence of MDA causes DNA damage and results in cell injury or death (Joshi *et al.*, 2011). Further studies have demonstrated that reactive species along with the ionized gases generated from plasma exposure lead to significantly faster bacterial inactivation (Fridman *et al.*, 2007; Dobrynin *et al.*, 2009).

Another significant role of plasma treatment is the mechanical disruption of bacterial cell is by continuous bombardment of the bacterial cell wall with charged particles, electrons and ions which breaks the bacterial cell structure by damaging the chemical bonds of

lipopolysaccharides and peptidoglycan of Gram positive and negative bacteria (Gallagher *et al.*, 2007; Yusupov *et al.*, 2013). The charged particles could accumulate on the surface and cause electrostatic stress. The etching caused to reaction between the charged particles and radicals and the organic molecules leads to breakage of the bonds in the cellular structure causing morphological changes in bacteria (Laroussi *et al.*, 2003). This erosion effect disrupts the cell wall, forming lesions and opening in the membranes, inducing penetration of reactive species or other toxic components inside bacterial cell thus leading to a release of intracellular contents in the surrounding medium (Kelly-Wintenberg *et al.*, 1999). Tian *et al.* (2015) estimated the leakage nucleic acid (DNA/RNA) from the cell as the function of plasma activation time. The production of UV photons of different wavelengths has been proposed to induce dimer and cross-dimers of thymine bases of DNA. Increases in thymine dimers, DNA single and double strand DNA was observed following exposure to plasma treatment (Dobrynin *et al.*, 2009a).

The lethality of ACP depends on various processing variables, including device setup and system parameters applied (voltage, frequency, flow rate, gas pressure), gas composition and the target organism (Alkawareek *et al.*, 2012; Dobrynin *et al.*, 2009a). By varying the process parameters involved in plasma generation, a multitude of mechanisms may act individually or synergistically.

Further, for an efficient application of ACP treatment a comparison to conventional decontamination methods and a detailed understanding of the system parameters, target characteristics, environmental conditions and product associated characteristics and matrices is required. The reactive species generated by the plasma source can come into contact with molecules from the surrounding air (homogeneous gas-phase reaction), resulting in the generation of ROS and RNS (Thirumdas *et al.*, 2015). They can act on the food in two different ways: they can penetrate the contact surface or can initiate chemistry where plasma



comes in contact with the solid medium. The ability of the plasma and its reactive species to penetrate the product depends on several factors that include; product composition, water content and porosity (Surowsky *et al.*, 2016). The penetration depth is additionally dependent on the plasma composition, its flow rate and half-lives of reactive species generated. Whilst, introduction of electric discharge into the liquid surface causes numerous heterogeneous reactions resulting in a great variety of different species (Fridman *et al.*, 2008), they can cause major oxidation of the organic constituents (such as proteins, carbohydrates) that are affected through the reactions of peroxy radicals. The basis of the treatment is the gas-liquid interface with transfer of the charged species between these two zones (Pivovarov and Tischenko, 2005). The complexity of the molecule-molecule interaction highlights the importance of process design, nature of environment and reactive species involved. Not all plasma systems are the same, thus a clear understanding of critical control parameters for any process technology is required for optimisation and validation. To achieve efficient inactivation efficacy, it is critical to understand the system and process parameters on the bacterial inactivation mechanisms. Therefore, further understanding of the influence of plasma, process parameters on the mode of action for biological species is needed. By tailoring the chemistry of the plasma, through appropriate tuning of the process parameters, the inactivation as well as the effectiveness of the gas discharge on microbes and biomolecules can be optimised.

## **1.6 Application of Atmospheric cold plasma**

The inactivation capabilities of ACP treatment have initiated new areas of research for this technology. The described atmospheric cold plasma systems above are very different in configurations (structure, power supply, working conditions) therefore they have a wide range of applications. ACPs have the potential to be applied in food processing and packaging of food products, wastewater cleaning, medical treatment (coagulate blood, induce

apoptosis in malignant tissues) and surface disinfection/sterilisation of medical equipment as well as heat sensitive materials.

### **1.6.1 Surface activation and treatment by ACP**

Activation and processing of substrate surfaces is one the oldest and most intensively studied application of plasma. Applications include: surface functionalisation, cleaning or etching and sterilisation; deposition of film and post treatment of coated surfaces (Bárdos and Baránková, 2010).

Traditional surface functionalisation is the introduction of specific groups onto a polymer surface which helps improve surface wettability, sealing, dye uptake and adhesion without affecting the physical properties of the polymer substrate. Surface treatment is performed by removing unwanted materials or contaminants (such as oils, grease, chemical and biological agents) from the substrate. Plasma treatment induces several physical and chemical processes within the plasma volume and plasma-polymer interface which modify surface properties. Using plasma deposition provides a significant reduction of gases permeability, good adhesion of carriers to the surface of polymer packaging material, transparency and flexibility (Schneider *et al.*, 2009). The gas plasma reaction has also demonstrated to be efficient inactivation technology of various bacteria, yeasts and fungi adhered to polymer surfaces of packaging material (Fitzgerald *et al.*, 2004). From the food industry perspective, current commercial application of cold plasma are primarily limited to packaging and widely reported for uses with polypropylene (PP), polyethelene (PE), polyethylene terephthalate (PET) and polytetrafluroethylene (PTFE) materials (Cheng *et al.*, 2006; Tendero *et al.*, 2006)

### **1.6.2 Food processing industries**

Fresh products are excellent sources of nutrients and ideal source of medium for the growth of microorganisms. Over the past few years an extensive number of outbreaks have occurred associated with fresh produce and meat products. ACP is an emerging non-thermal

pasteurisation method used for the enhancement of food safety (Kim *et al.*, 2011). A number of studies have indicated that cold plasma technology is a promising antimicrobial technology for food products and food processing equipment. They have wide range of potential applications in the food industry including food surfaces like meat, fish, fresh produces, nuts; particulate foods such as seeds, nuts, and herbs (Kim *et al.*, 2014; Ling *et al.*, 2015; Ziuzina *et al.*, 2015). The most attractive features of cold plasma treatment is their low temperature property, high efficiency of microbial inactivation, reduced water usage and lack of chemical residues which makes it ideal for use in food industry.

Product shelf-life extension is another important global challenge to support food security and minimise waste. Cold plasma can be successfully applied for microbial destruction on food products to increase shelf life. Wang *et al.* (2016) showed in-package plasma treatment with MAP resulted in significant 4-log reduction of bacterial population and could extend the shelf life of fresh chicken meat without compromising product quality. A list of recent applications of cold plasma technology for food applications is shown can be found in **Table 1.6**. These data demonstrate high variability in the total bacterial inactivation achieved by plasma treatment which is highly influenced by bacterial strain, physiological state of microorganism; produce utilised, treatment conditions, plasma source, working gas and gas flow rate used. This variability complicates the overall comparison of plasma efficacies.

**Table 1.6: Applications of non-thermal plasma for inactivation of microorganisms on food matrices.**

<b>Food products</b>	<b>Plasma source</b>	<b>Working gas</b>	<b>Bactericidal reduction</b>	<b>References</b>
<b>Mung bean sprouts</b>	Atmospheric pressure plasma jet	Air	A 30-min plasma-activated water treatment of mung bean sprouts reduced total aerobic bacterial counts by 2.32-log <sub>10</sub> CFU/g.	(Xiang <i>et al.</i> , 2019)
<b>Ham</b>	Surface-micro-discharge-plasma	Ambient air with 45–50 and 90% of humidity	<i>S. Typhimurium</i> 1.14 log steps and <i>L. monocytogenes</i> 1.02 log steps	Lis <i>et al.</i> , 2018
<b>Red chicory</b>	Dielectric Barrier Discharge	Air	<i>E. coli</i> 1.35 log MPN/cm <sup>2</sup> , <i>L. monocytogenes</i> 2.2 log CFU/cm <sup>2</sup>	Pasquali <i>et al.</i> , 2016
<b>Pork-butt and beef-loin</b>	DBD plasma	Nitrogen and oxygen.	<i>L. monocytogenes</i> , <i>E. coli</i> , <i>S. Typhimurium</i> were reduced by 2.04, 2.54, and 2.68 Log CFU/g in pork samples and 1.90, 2.57, and 2.58 Log CFU/g in beef samples, respectively.	Jayasena <i>et al.</i> , 2015
<b>Lettuce</b>	Dielectric Barrier Discharge	Air	<i>Salmonella</i> , <i>L. monocytogenes</i> and <i>E. coli</i> was reduced by 2.4, 2.3 and 3.3 cfu/sample by 5 min of treatment	Ziuzina <i>et al.</i> , 2015
<b>Strawberries</b>	Atmospheric	98% Ar and 2%	<i>Staphylococcus aureus</i> 2.3 log at day-0	Ma <i>et al.</i> , 2015

	pressure plasma jet	O <sub>2</sub>	storage, while 3.4 log at day-4 storage.	
<b>Fresh cut Lettuce and Sprout</b>	Microwave driven discharge	Air	Up to 6 log and 2.5 log steps for <i>P. marginalis</i> and <i>P. carotovorum</i> on salad and sprout respectively	Schnabel <i>et al.</i> , 2015
<b>Strawberries</b>	Dielectric Barrier Discharge	Air	Background microflora was reduced by 2 logs with negligible effects on colour or firmness	Misra <i>et al.</i> , 2014a
<b>Pepper powder</b>	Microwave-Cold plasma	N <sub>2</sub> , N <sub>2</sub> :O <sub>2</sub> (99.3:0.7), He, He:O <sub>2</sub> (99.8:0.2)	<i>A. flavus</i> 2.5 log reduction	Kim <i>et al.</i> , 2014
<b>Cherry tomatoes</b>	Dielectric Barrier Discharge	Air	Plasma treatment for 10, 60, and 120 s resulted in reductions of <i>Salmonella</i> , <i>E. coli</i> , and <i>L. monocytogenes</i> to undetectable levels	Ziuzina <i>et al.</i> , 2014
<b>Carrots Cucumber Pear</b>	Cold plasma jet	Air	90% of <i>Salmonella</i> population (10 <sup>6</sup> CFU/ml) from carrot slices and 80% from cucumber and pears slices	Wang <i>et al.</i> , 2012
<b>Sliced ready-to-eat (RTE) meat product</b>	DBD Plasma	Air; sample sealed in 30% oxygen and 70% argon	<i>L. innocua</i> ranging from 0.8 ± 0.4 to 1.6 ± 0.5 log cfu/g	Rød <i>et al.</i> , 2012
<b>Cheese</b>	DBD plasma	He and He/ O <sub>2</sub>	<i>E. coli</i> 1.47 log cycles with helium and 1.98	Lee <i>et al.</i> , 2012

		mixture	log cycles with He/O <sub>2</sub> mixture	
<b>Milk</b>	Atmospheric plasma corona discharge	Air	54% reduction in the population of <i>E. coli</i> cells	Gurol <i>et al.</i> , 2012
<b>Chicken muscles and skins</b>	Cold atmospheric plasma pen	100% He or 98%:2% He:O <sub>2</sub> plasma	3 log reduction of <i>L. innocua</i>	Noriega <i>et al.</i> , 2011b

DBD-Dielectric barrier discharge, APJ-Atmospheric plasma jet, ACP- Atmospheric Cold plasma, APP-Atmospheric pressure plasma, APC-Atmospheric plasma corona discharge; He- helium, Ar-Argon, O<sub>2</sub>-Oxygen, N<sub>2</sub> Nitrogen

### **1.6.3 Food-Wastewater Treatment**

Over past few years, significant progress has been archived in developing of new technologies for wastewater treatment based on electro-chemical and plasma-chemical principles. A potential application of plasma in liquids can be subdivided in three main groups: electric discharge above the liquid surface, direct liquid discharge and discharge in bubbles/vapours in liquids (Locke *et al.*, 2005). The introduction of the electric discharge into the liquid surface causes a number of chemical reactions (Fridman, 2008; Locke *et al.*, 2012). Major oxidation degradation of the organic matter and biological content governing by reactions of the peroxy radicals. The basis of the treatment is transfer of the charged species at the gas-liquid interface (Pivovarov and Tischenko, 2005). The reactive species generated are utilised for interaction with agents contained in the liquid medium which further promotes degradation of the organic content present in the liquid. A better understanding of microbial inactivation mechanism by ACP is needed to define treatments that alone or in combination with other control agents may assure the safety of wastewater when released into the environment.

### **1.6.4 Advantages of ACP**

To control persistent strains and emergent resistance among microbial populations across diverse sectors requires more intensive and effective disinfection strategies. The food manufacturing industries search for alternative methods and technologies. In recent years, interest in the application of non-thermal plasma has significantly increased. The remarkable characteristics of ACP includes a strong thermodynamic non-equilibrium nature, low gas temperature, presence of reactive and high sensitivity which provides tremendous potential to utilise ACP sources in wide range of applications. The advantages of ACP treatment can be summarised as follows:

- Typical cold atmospheric cold plasma treatments are suitable for rapid generation of plasma reactive radicals and plasma reactions.
- It can be performed at room temperature, under atmospheric pressure without any catalyst.
- It has potential to inactivate a wide range of microorganisms like bacteria, bacteriophages, viruses, and fungi.
- Demonstrates efficient treatment within short treatment times at low temperature without significantly affecting the quality of the treated product.
- They are cost effective and energy efficient, where smart design of systems based on water, air and electricity can be functionalised towards antimicrobial effect.

## **1.7 Research Aim and objectives**

In order to establish innovative applications of ACP applications in food sector and to integrate the ACP treatments for increase in value of food produce into existing value-added chains, detailed knowledge of plasma associated effects is crucial. The overall objective of this study was to comprehensively investigate the efficacy of atmospheric cold plasma treatment against microbial species mainly associated with the food industries. The specific objectives of the study are:

- To investigate primary experiment conditions, the effect of ACP systems and treatment parameters (applied voltage, plasma treatment time, post treatment storage time, post treatment retention time, and storage conditions) against a range of key pathogenic and spoilage microorganisms commonly implicated in food environment were evaluated.
- To investigate the optimised ACP treatment parameters against complex microbial multicellular communities such as biofilms. Chapter 4 focused on: (i) determining



the effect of atmospheric cold plasma against inactivation of key foodborne pathogens and spoilage microorganisms as mono or mixed species biofilm in model media as well as attached on lettuce, (ii) to determine the effect of environmental stress conditions on biofilm formation on fresh produce and its effects on ACP antimicrobial efficacy.

- To investigate the role of bacterial and environmental stress conditions on the antimicrobial efficacy of ACP treatment. Chapter 5 focused on understanding the role of stress responses in *Listeria monocytogenes* and to investigate the applicability of ACP as a decontamination technology to control *Listeria* for fresh produces. Several knockout mutants associated with stress regulation were evaluated in this study with respect to their stress responses, plasma inactivation, RONS intensity and gene expression post plasma treatment.
- To determine the efficacy of cold plasma functionalised water for decontamination processes in food industry, Chapter 6 focused on the antimicrobial efficacy of cold plasma functionalised water for decontamination of fresh produces and the wastewater generated fresh produce washing.
- Food processing industries are associated with large discharge of wastewaters and by-products that potential have impact on natural environment and health, therefore Chapter 7 examines: The effectiveness of ACP in removing key pathogenic microorganisms from model dairy and meat wastewaters along with the environmental safety impact of ACP treated effluent on eco-toxicity markers.

## Chapter 2 Methods and Materials

### 2.1 Microbial strains and growth conditions

The list of microbial strains and treatment media used in this study are listed in the **Table 2.1**. Microorganisms were stored at -80 °C in the form of the protective beads (Pro-Lab Microbank®, Wirral, UK). The working cultures of *E. coli*, *S. enterica*, *L. monocytogenes* were cultured on Tryptic soy agar (TSA, Biokar Diagnostics, Allonne, France) at 37 °C, while *B. thermosphacta* was cultivated on TSA supplemented with 0.01M CaCl<sub>2</sub> at 26 °C, *C. perfringens* on Reinforced clostridial agar (RCA) anaerobically at 37°C using Anaerocult® A GasPak (Merck, Darmstadt, Germany), *E. faecalis* on Brain heart infusion agar (BHIA, Biokar Diagnostics, Allonne, France) and *P. fluorescens*, *E. carotovora* & *B. megaterium* were cultured on TSA and incubated at 30 °C. After 24 h of incubation all the plates were stored at 4 °C.

**Table 2.1: Bacterial strains used in this study**

Microorganisms	Growth media	Acquired from
<i>Escherichia coli</i> NCTC 12900 (non-toxicogenic O157:H7)	TSB (+G)	National Collection of Type Cultures, Health Protection Agency, London, UK
<i>Enterococcus faecalis</i> ATCC 29212	BHIB	Microbiological stock culture, DIT
<i>Clostridium perfringens</i> ATCC 13124	Thioglycollate broth	Microbiologics, Ireland
<i>Bacillus megaterium</i> LZB026	TSB (+G)	Microbiological stock culture, DIT
<i>Listeria monocytogenes</i> NCTC 11994	TSB (+G)	Microbiological stock culture, DIT
<i>L. monocytogenes</i> EGD-e Serotype 1/2a (Parent strain)	BHIB	Dr Conor O’Byrne, Bacterial Stress response group,

<i>ΔsigB</i>		Department of Microbiology, NUI Galway.
<i>Δgad D1</i>		
<i>Δgad D2</i>		
<i>Δgad D3</i>		
<i>Δgad D2D3</i>		
<i>ΔprfA</i>		
<i>ΔrsbR</i>		
<i>Δlmo0799</i>		
<i>Δlmo0799-C56A</i>		
<i>Listeria innocua</i> NCTC 11288	TSB (+G)	Microbiological stock culture, DIT
<i>Salmonella enterica</i> Typhimurium ATCC 14028	TSB (+G)	Microbiological stock culture, DIT
<i>Brochothrix thermosphacta</i> ATCC 11509	TSB (+G)	Microbiologics, Ireland
<i>Pseudomonas fluorescens</i> LZB065	TSB (+G)	Microbiological stock culture, DIT
<i>Erwinia</i> <i>carotovorum</i> subsp. <i>carotovorum</i>	TSB (+G)	Leibniz Institute DSMZ, Germany

TSB: Tryptic Soya broth (Scharlau Chemie, Barcelona, Spain), (+G): with Glucose present

To investigate microbial stress mechanism post ACP exposure, eight mutants with knockout genes associated with stress regulation were selected to investigate their role against ACP and gene expression level after plasma treatment **Table 2.2**.

**Table 2.2: List of knockout mutants and their characteristics**

Microorganism	Description	Reference
<i>Listeria monocytogenes</i> strains		
EGD-e (wild type)	Serotype 1/2a	
EGD-e <i>ΔsigB</i>	Plays an important role under multiple stress conditions (heat, high osmolarity, high ethanol concentrations, high and low pH, and oxidising	Utratna <i>et al.</i> , 2011

	agents)	
EGD-e $\Delta$ gad D1	Encodes a glutamate decarboxylase important for acid tolerance and play significant role in overall virulence of <i>L. monocytogenes</i>	Feehily <i>et al.</i> , 2014
EGD-e $\Delta$ gad D2		
EGD-e $\Delta$ gad D3		
EGD-e $\Delta$ gad D2+ $\Delta$ gad D3		
EGD-e $\Delta$ prfA	Listeriolysin-positive regulatory factor A Virulence Regulator factor, influence expression of several virulence factors such as biofilm formation	Guldimann <i>et al.</i> , 2017
EGD-e $\Delta$ rsbR	Stress regulator (positive regulator for sigma B activity)	Donaldson <i>et al.</i> , 2009
$\Delta$ lmo0799	Sulphate Transporter and Anti-Sigma factor antagonist domain of the 'stressosome' complex proteins RsbS and <i>RsbR</i> , regulators of the bacterial stress activated alternative sigma factor sigma-B by phosphorylation; $\Delta$ lmo0799 C56A: Cys is replaced by Ala	O'Donoghue <i>et al.</i> , 2016
$\Delta$ lmo0799-C56A		

## 2.2 Cell culture

Cell lines were kindly obtained from the culture stocks of Dr Michelle Giltrap, FOCAS research Institute, Technological University Dublin (Dublin, Ireland). The following established fish cell lines were used: RTG-2 cells (Catalog No. 90102529) derived from rainbow trout gonad and PLHC-1 (CRL-2406) derived from a hepatocellular carcinoma in the topminnow. Both the cells were cultured and maintained in Dulbecco's modified medium nutrient mixture/F-12 Ham (DMEM) supplemented with 10% (RTG-2) or 5% (PLHC-1) fetal bovine serum (FBS) and 45 IU ml<sup>-1</sup> penicillin, 45 mg/ml streptomycin, 25 mM HEPES and 1% non-essential amino acids. Cultures were maintained in a refrigerated incubator at 20 °C (RTG-2) or 30 °C (PLHC-1) under normoxic atmosphere.

## **2.3 Liquid media under investigation**

Several liquid media were used for the bacterial inactivation studies. Preliminary studies were carried out in simple phosphate buffer solution (PBS, Oxoid LTD, UK) while meat studies were carried out in meat model media, fresh produce studies in lettuce broth and wastewater studies in model dairy effluent and meat effluent.

### **2.3.1 Preparation of model meat media and inoculum**

Model meat broth consisted of 12% beef extract (BE, Scharlau Chemie, Barcelona, Spain) in distilled water and was sterilised by autoclaving at 121 °C for 15 min to prevent any background bacteria contamination.

Overnight culture of *B. thermosphacta* was prepared by inoculating in 12% beef extract broth (BE, Scharlau Chemie, Barcelona, Spain) at 26 °C for 18 h. Cells were then centrifuged at 10,000 rpm for 10 min and the cell pellet was washed and re-suspended in 10 ml of PBS. The final bacterial cell density was adjusted to  $10^{7-8}$  CFU/ml in PBS using McFarland reagent (BioMerieux, Marcy l'Etoile, France), 3% or 12% BE.

### **2.3.2 Preparation of lettuce broth (LB) media and inoculum**

LB was prepared according to procedures described previously by Jahid *et al.* (2015) with some modifications. Briefly, small section of iceberg lettuce was added into a sterile stomacher bag (BA6040, Seward LTD, UK) and was stomached for 3 min. The extracted juice was centrifuged (10,000 rpm for 10 min at 4 °C) twice to remove coarse particles. The supernatant obtained was membrane filter sterilised (0.2 µm, pore size, Millipore, Ireland) and was diluted to 12% using sterile distilled water. All broths were freshly prepared before each experiment and stored at 4 °C until use.

### **2.3.3 Preparation of *L. monocytogenes* EGD-e and its knockout mutant cell suspensions and inoculum**

The wild and mutant cells were grown in sterile brain heart infusion broth (BHIB) for 16-18 h at 37 °C. The overnight cultures were washed thrice with PBS by centrifugation at 10,000 x g for 5 min and adjusted to 0.5 McFarland standards (BioMerieux, Marcy l'Etoile, France). Finally, cell suspensions with concentration of 10<sup>8</sup> CFU/ml were prepared in PBS (planktonic) or BHIB (biofilm).

### **2.3.4 Preparation of model wastewater effluents and inoculum**

#### **2.3.4.1 Preparation of model effluent**

Model dairy effluent (DE) was prepared as reported by Daverey and Pakshirajan (2011) which contained 2 g/L semi-skimmed milk powder (TESCO, Dublin, Ireland), 0.2% (w/v) milk fat (East end Foods, UK), 0.01% (w/v) sodium hydroxide (Sigma-Aldrich, Arklow, Ireland) and sterile distilled water adjusted the final effluent pH to 6.0. The milk powder was composed of 35% proteins, 50.3% carbohydrates, 0.6% fat, 1.05% calcium, 0.8% phosphorus, 0.095% magnesium. The organic content in dairy effluent varies with the manufactured product; therefore, the relative impact of organic milk fat content on bacterial inactivation efficiency was examined. The milk fat content as an experimental variable ranged between 0.2 g/L to 4 g/L.

Model meat effluent was prepared using the procedure of Barrera *et al.*, (2012) with a few modifications. The synthetic meat effluent consisted of commercial meat extract powder (Scharlau Chemie, Barcelona, Spain) 1950 mg/L, glycerol (C<sub>3</sub>H<sub>8</sub>O<sub>3</sub>) (Sigma-Aldrich, Arklow, Ireland) 200 mg/L, ammonium chloride (NH<sub>4</sub>Cl) (Sigma-Aldrich, Arklow, Ireland) 360 mg/L, sodium chloride (NaCl) 50 mg/L in sterile distilled water. The effluents were prepared as required and the concentration was maintained throughout the study.

#### **2.3.4.2 Inoculum preparation**

Bacterial strains of *Escherichia coli* NCTC 12900 (non-toxigenic O157:H7), *Clostridium perfringens* ATCC 13124 and *Enterococcus faecalis* ATCC 29212 were used as the principle indicators in this study. A subculture of each strain was prepared by inoculating in their respective broth as mentioned in the Table 2.1 and incubating it at 30-37 °C for 24 h. The cells were harvested by centrifugation at 13,000 rpm for 4 min. The supernatant was washed twice with sterile PBS. The cell pellet obtained was re-suspended in PBS. The bacterial density was determined using a 600 nm spectrophotometer and confirmed by plate count. The final bacterial concentration was adjusted to  $10^{5-6}$  CFU/ml in the model effluents.

#### **2.3.4.3 Preparation of mixed bacterial culture in effluents**

A cocktail of microorganisms was used to represent the probability of a variable microbial load in dairy and meat wastewaters. Three different bacteria were used including: (1) *E. coli*, (2) *E. faecalis*, and (3) *C. perfringens*. The overnight cultures were purified and washed with PBS as described previously. Equal volumes of each bacterial cultures were mixed together (1:1:1) to obtain final concentration of approx.  $10^5$  CFU/ml and were added to the model effluent.

#### **2.3.4.4 Preparation and analysis of *B. megaterium* spores**

Spores of *B. megaterium* were cultivated as per the method described by Garvey *et al.* (2013) with modifications. Spores were prepared by growing the bacterial strain on TSA supplemented with 3 mg/L of manganese sulphate for 8 days at 30 °C. Spores were collected by flooding the plate with 10 ml of PBS and rubbing the surface gently with a sterile spreader. After harvesting, the cells were washed twice with PBS by centrifugation at 10,000 rpm for 10 min at 4 °C. The samples were then heated at 85 °C for 25 min to inactivate any vegetative cells and immediately cooling it in ice water bath. After heating, spores were washed twice by centrifugation (10,000 rpm for 10 min at 4 °C) in sterile PBS. The purity of

the sample was determined using malachite green spore staining method and phase contrast spectroscopy (Rowan *et al.*, 2001). The purity of the final sample was calculated from the bacterial spore suspension and performed by drawing 20 µl of sample on clean glass slide and stained by malachite green and observed under phase contrast microscope. The concentration of the spore suspension was determined by plating onto TSA agar plates and incubating aerobically at 30 °C for 24 h. The spore suspension prepared was stored at 4 °C until use.

## **2.4 Bacterial Biofilm formation on abiotic surfaces**

### **2.4.1 Inoculum preparation**

In order to study the effect of ACP treatment on bacterial biofilm, bacterial biofilm of *E. coli*, *S. enterica*, *L. monocytogenes*, *P. fluorescens*, *E. carotovora* were formed in model fresh produce media (3% and 12% lettuce broth). While biofilm forming capacity of meat spoilage bacteria *B. thermosphacta* was carried out in meat model media (12% BE). Overnight culture of bacterial suspension was prepared by inoculating in their respective media (Table 2.1). The bacterial suspension was prepared by washing the overnight bacterial cells thrice with sterile PBS at 10,000 rpm for 10 min. The pellet obtained was re-suspended in 3% and 12% LB or 12% BE. The final bacterial concentration was adjusted to  $10^{7-8}$  CFU/ml using McFarland standard (BioMérieux, Marcy-l'Etoile, France) which was confirmed by plate count method.

### **2.4.2 Monoculture Biofilm formation**

A 96 well microtitre plate method was used for biofilm formation was described in Ziuzina *et al.* (2015). The prepared bacterial cultured suspension (200 µl) was dispensed into the 96 well microtiter plate and incubated statically for 24 h to 48 h at 30 °C (*B. thermosphacta*, *P. fluorescens*) or 37 °C (*E. coli*, *S. enterica*, *L. monocytogenes*, *E. carotovora*). The supernatant (with non-adherent cells) from each well was replaced with fresh broth after 24 h incubation. Sterile LB and model meat media without inoculum were used as a negative control.



### **2.4.3 Mixed culture biofilm formation**

For multispecies biofilm formation, combination of *P. fluorescens*, *L. monocytogenes*, *S. enterica*, *E. coli* bacteria were selected so as to investigate individual contribution and biofilm forming capacity of each bacteria under mixed bacterial conditions. These bacteria are important strong biofilm formers in fresh and minimally processed produce. The individual inoculum was described in section 2.4.1 and mixed in equal volume (1:1:1:1 or 1:1 ratio) adjusting the bacterial concentration to 7.0 Log<sub>10</sub> CFU/ml in 12% lettuce broth. Bacterial biofilms were produced similarly to mono-species biofilm by adding 200 µl of prepared dual/mixed bacterial suspension (*P. fluorescens* + *L. monocytogenes*, *P. fluorescens* + *E. coli*, *P. fluorescens* + *L. monocytogenes* + *S. enterica* + *E. coli*) into wells of microtiter plate and incubated at 30°C for 24-48 h to form biofilms under static condition.

At the end of incubation, the supernatant was carefully aspirated and rinsed thrice with PBS to remove non-adherent cells. Prior to each experiment the biofilm grown on the microtiter plate was air dried for 60 min. The biofilm growth and density were monitored in a 96 well microtiter plate using Crystal violet (CV) assay. The antibacterial effect of applied ACP treatment on bacterial biofilm was quantification by plate count (PC) and XTT assay.

### **2.5 Preparation of meat samples**

Samples of lamb chops were purchased from a local retailer, Dublin, Ireland. Under aseptic conditions, approximately 25 g of lamp chop was spot inoculated with 1 ml of prepared *B. thermosphacta* bacterial suspension (10<sup>7-8</sup> CFU/ml) and allowed to dry for 1 h in a laminar flow safety cabinet to facilitate surface attachment of the bacteria. Samples were placed inside a plastic tray (196 x 154 mm and 45 mm depth), flushed with 30% CO<sub>2</sub> + 70% O<sub>2</sub> gas mixture at a controlled flow rate of 0.5 L/min for 1 min using the vacuum packaging machine

(Lavezzini VG600, Kent, UK) and sealed prior to treatment. The meat samples were stored at 4 °C before and after plasma treatment.

For the microbiological analysis, inoculated untreated samples were prepared to determine initial sessile bacterial challenge following attachment; Inoculated treated samples to assess efficacy of the ACP treatment, un-inoculated untreated samples to estimate the initial micro-flora and uninoculated treated samples to analyse effect of ACP treatment on the background micro-flora respectively.

## **2.6 Preparation of produce**

Lettuce (Irish iceberg) was purchased on the day of the experiment from the local supermarket and stored at 4 °C until use. The outer leaves were separated and inner leaves were used for the experiment. Lettuce pieces were cut (5 x 5 cm) aseptically and rinsed with sterile distilled water to clean and remove unattached bacteria. Washed lettuce samples were dried in bio-safety cabinet for 20 min.

For lettuce inoculation, 100 µl of prepared bacterial suspension was spot inoculated and dried in bio-safety cabinet with air flow for 2 h. Following air drying, the samples were transferred to sterile petri-dish and stored for 0 or 24 h at 4 °C.

For biofilm formation studies on lettuce, the lettuce inoculation procedure was carried out by Kroupitski *et al.* (2009) method with minor modification. The cut lettuce pieces were submerged in a beaker containing 300 ml of bacterial suspension (adjusted to  $10^{7-8}$  CFU/ml) of *L. monocytogenes* and *P. fluorescens* (mixed in equal ratio 1:1) for 2 h in laminar biosafety cabinet. Following incubation, the samples were washed with sterile distilled water in separate beaker in order to remove any unattached bacteria. The lettuce pieces were drained of excess water and were allowed to dry on sterile aluminium foil for 15 min each side in laminar air flow. Following air drying, the samples were transferred to sterile petri-dish and stored for 24-48 h at either 4 °C or 15 °C.

## **2.7 Stress studies**

### **2.7.1 Stress responses in *L. monocytogenes* and *P. fluorescens***

For stress exposure experiments, washed bacterial cells of *L. monocytogenes* and *P. fluorescens* were suspended in either lettuce broth acidified to pH 4 using 33% acetic acid (Sigma-Aldrich Co., Arklow, Ireland) then incubated for 1 h at 37 °C or in lettuce broth and stored in 4 °C for 1 h. The bacterial cells inoculated into plain lettuce broth incubated 37 °C for 1 h served as negative non-stress control.

### **2.7.2 Mild acid stress and cold stress of *L. monocytogenes* mutants**

To obtain mild stress-habituated cells, two stress conditions were imposed i.e. acid and cold stress. The cells were prepared by suspending the washed wild and mutant cells in either in PBS and stored in 4 °C for 1 h or acidified PBS (pH 4.0 using acetic acid) and then incubated for 1 h at 37 °C. The non-stress cells in PBS at 37 °C served as negative control. Cells prepared under this range of conditions were dispensed in 96 wells and were then treated with ACP.

## **2.8 Experimental design**

### **2.8.1 ACP-DBD plasma system**

The plasma treatment was performed using dielectric barrier discharge (DBD) ACP system which is an in-house set up at Technological University Dublin. The schematic plan of the DBD system is represented in the **Figure 2.1**. DBD-ACP consists of high voltage set-up transformer (Phenix Technologies, Inc., USA) with maximum voltage output of 120 kV at 50Hz. The system consists of two aluminium disk electrodes (outer diameter = 158 mm) with a dielectric material (1 mm thick boards) in between them to prevent the transition into arc regime (Misra *et al.*, 2014b). The two electrodes were separated by polypropylene container (310 x 230 x 40 mm) which also acts as dielectric barrier. The distance between the

electrodes was 30 mm, which was equal to the height of the polypropylene container and dielectric boards used for the plasma treatment. The distance between the two electrodes was maintained constant for all experiments. The system was operated at variable voltage range of 60-80 kV<sub>RMS</sub> at atmospheric pressure using atmospheric air as working gas. Voltage and input current characteristics of the system were monitored using an InfiniVision 2000 X-Series Oscilloscope (Agilent Technologies Inc., USA). After samples were loaded, each container was sealed in a high barrier polypropylene bag (Cryovac, B2630, USA) so to trap the reactive species generated by ACP treatment inside the container.

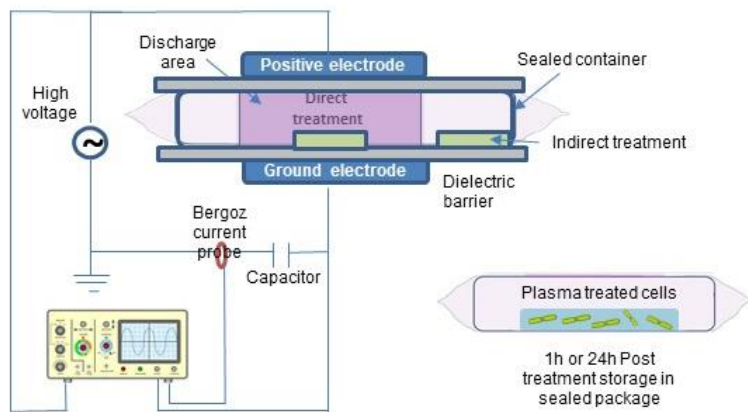

**Figure 2.1: Schematic of the experimental setup of the DBD-120 ACP plasma system**

For direct plasma treatment, the sample container was placed directly between the two electrodes i.e. within the range of plasma discharge. The distance between the top electrode and the sample for direct treatment was approximately 10 mm. While in case of indirect plasma treatment, the sample was placed at the corner of the container; so as to achieve treatment outside the plasma discharge. The distance between the samples and the centre of the electrodes varied from 120-160 mm owing to sample distribution on the plate. Each container was sealed with a high barrier polypropylene bag (B2630; Cryovac Sealed Air Ltd., Duncan, SC, USA) and placed between the aluminium electrodes.

For post treatment storage studies, ACP treated samples were kept sealed and stored for 0, 1 or 24 h at room temperature or at refrigeration temperature for food related studies including lettuce broth, beef broth, lettuce and meat samples. While, ACP treated wastewater samples were retained by unsealing the package and storing for 0-10 min before analysis.

### 2.8.2 ACP-DBD submerged plasma system

**Figure 2.2 (a)** shows the schematics of atmospheric cold plasma (ACP) treatment system used in this study. The ACP treatment system is based on a submerged dielectric barrier discharge (DBD) plasma source, which is developed and built in Technological University of Dublin (Submerged DBD plasma system). The system design and set up as well as diagnostics described below were carried out by Dr. Peng Lu, TU Dublin. The submerged DBD plasma source which employs a conventionally coaxial electrode configuration is submerged into the liquid. The high voltage electrode is sealed in a quartz tube, and ground electrode is inserted into the liquid. The gap between the two coaxial quartz tubes was 2 mm as shown in **Figure 2.2 (b)** of the geometry of coaxial DBD tube. The liquid serves as both an additional dielectric barrier layer and the coolant for the discharge. Therefore, the plasma column length is determined by the depth of the liquid in the beaker. In this study, the liquid is contained in a cylindrical beaker made of borosilicate glass (internal diameter of 100 mm and height 135 mm) with total volume of 800 ml. Air is used as the plasma working gas and its flow rate is controlled by a mass flow controller (KOFLOC DF300C). The post-discharge afterglow plasma effluent is bubbled into the liquid through four gas diffusers which are attached at the end of the tube. The gas diffuser generates microbubbles for production of agitation and distribution of plasma effluent in the washing beaker. The plasma discharge is driven by a high voltage (HV) AC power supply (PVM500, Information unlimited). Applied voltage and discharge current were monitored by a HV probe (Tektronix P6015A) and a wideband current transformer (Stangenes Industries CT 0.5W), respectively. Lissajous  $Q$ - $V$

figures were used to calculate the DBD plasma power. The measurement capacitance is 4.7 nF. **Figure 2.3** (a) shows the waveforms of applied voltage, plasma current and voltage across the measurement capacitor, the frequency of applied voltage is 25.8 kHz. Figure 2.3 (b) shows a Lissajous  $Q$ - $V$  figure of the single discharge period, from which it is calculated that the average DBD power is about 7.45 W.

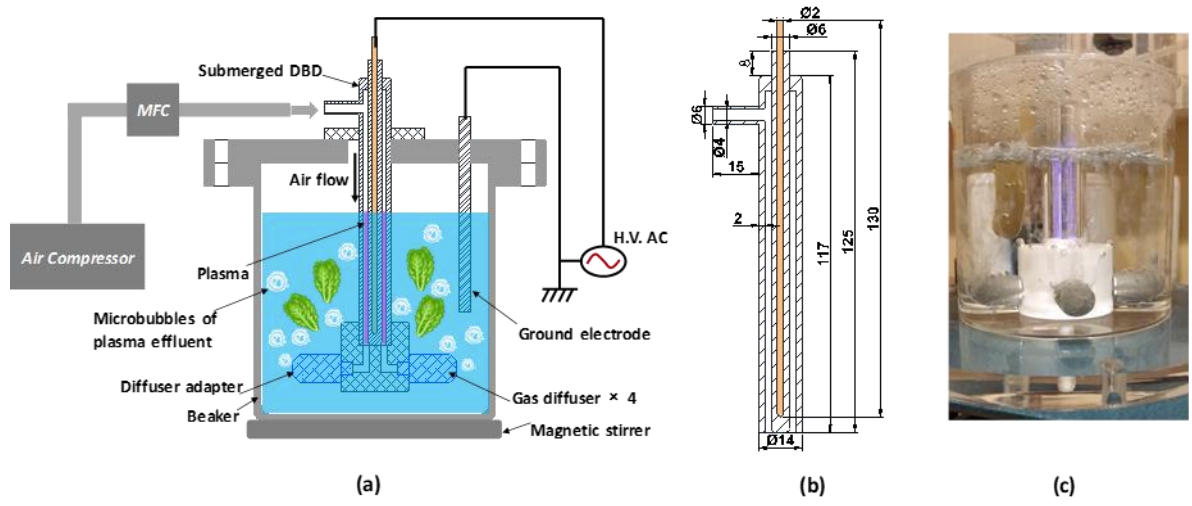

**Figure 2.2: The experimental setup for treatment of lettuce and wash-water using Submerged DBD-ACP system: (a) system setup, (b) geometry of submerged DBD plasma source and (c) photograph of plasma generated in submerged DBD plasma source.**

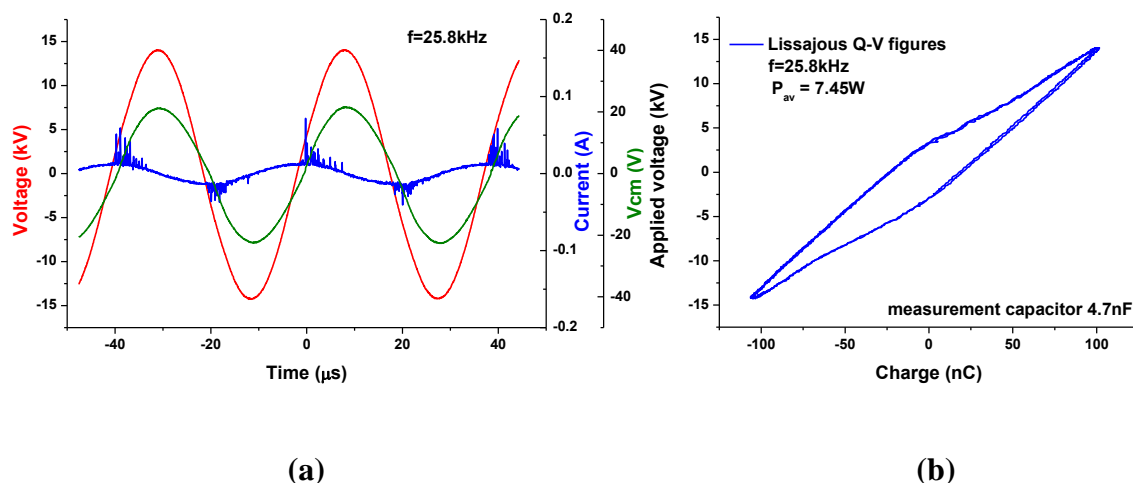

**Figure 2.3: (a) Waveforms of applied voltage, discharge total current and voltage across the measurement capacitor, (b) Lissajous Q-V figure for energy consumption measurement in one period of applied voltage**

### 2.8.3 Plasma treatment of Liquids

#### 2.8.3.1 ACP treatment of PBS and meat model media

Bacterial suspensions (100 μl) in PBS and 3 % BE were prepared in 96 well microtiter plates, placed at the centre of the polypropylene plastic container. The bacterial samples were then treated with plasma placed directly between the electrodes of the system. A variable voltage range of 60-80 kV<sub>RMS</sub> and treatment times from 15-300 s were used. The effect of post storage period and storage temperature was evaluated; samples were stored for 1 h or 24 h at room temperature (PBS) or 4°C (BE) post plasma treatment. Experiments were performed in duplicate and replicated twice. The bacterial suspension without any plasma treatment was kept as a negative control and stored under similar conditions. Depending on the availability of the DBD-ACP system, bacterial strains were prepared and treated on different days.

### **2.8.3.2 ACP treatment of lettuce broth**

For planktonic cell studies and stress studies, 100 µl of bacterial suspension prepared in PBS or lettuce broth was suspended in 96 well microtiter plates, placed at the centre of the polypropylene plastic container. Bacterial cells suspended in lettuce broth were exposed to direct plasma treatment at 80 kV for 60-120 s with a post treatment storage time of 24 h at 4°C.

### **2.8.4 Plasma treatment of biofilms on abiotic surface**

In order to study the effect of ACP on the bacterial biofilm, 48 h biofilm (mono & mixed biofilm) grown on microtiter plate was subjected to direct ACP treatment at 80 kV for 60 s, 120 s and 300 s. After treatment the treated samples were subjected to post treatment storage for 24 h at 4 °C.

### **2.8.5 Plasma Treatment of meat**

The packed lamb samples were treated at 80 kV of voltage for 1 min. The lamb samples were stored at 4 °C for predetermined interval days: 0, 1, 4, 7, 10, and 13 (to evaluate potential of shelf life extension). All experiments were carried out in duplicates and replicates to ensure reproducibility of the experimental data.

### **2.8.6 Plasma Treatment of lettuce sample**

For bacterial biofilm on lettuce, the inoculated lettuce samples kept in sterile petri dish enclosed in a sealed polypropylene container and exposed to indirect in-package treatment using ACP-DBD120 system for 2 min and 5 min. All samples were treated at 80 kV with a post treatment storage time of 24 h at 4 °C. Experiments were performed in duplicate and replicated twice. Inoculated lettuce samples without any plasma treatment was kept as a negative control and stored under similar conditions as treated samples.



Inoculated lettuce samples were immersed in the plasma reactor (ACP-DBD submerged plasma system) containing 700 ml of sterile distilled water and stirred at speed approximately 450 rpm using Magnetic Stirrer (IKA C-MAG HS 7). The ratio of vegetable sample to wash water was 15 g to 700 ml of wash water (~1:50). Plasma treatment was operated at voltage of 20 kV for treatment period of 0-10 min. The temperature was continuously monitored, and it did not exceed more than 30 °C.

### **2.8.7 Independent Antimicrobial effect of pH**

ACP treatment is known to cause a reduction in pH from neutral to acidic therefore to determine whether acid production was responsible for the strong antimicrobial activity, lettuce inoculated with *L. innocua* was exposed to different acidic conditions (pH 3-5) for exposure times equivalent to those of the plasma treated water. The working solution was prepared by adding 1N hydrochloric acid (HCl) to sterile deionised water and adjusting the pH to 3, 4 and 5. The prepared acid solutions were then exposed to same ratio of vegetable to water (~1:50) of  $10^{7-8}$  CFU/ml *L. innocua* and held for 0-10 minutes. Colony count assay was performed for quantification of surviving bacteria as described previously.

### **2.8.8 Chlorine treatment**

Sodium hypochlorite solution and its derivatives are commonly used for sanitizing fresh produce (Warriner *et al.*, 2009) and in fact, chlorine is a very potent disinfectant with powerful oxidizing properties (Suslow, 1997). High concentration of sanitisers (100-300 mg/L) are commonly applied in food industry (Beuchat, 1998; Martínez-Hernández *et al.*, 2015). Chlorinated water was prepared by adding sodium hypochlorite (NaOCl) solution containing 6-14% active chlorine (EMPLURA® Sigma-Aldrich, Arklow, Ireland) to sterile distilled water to obtain concentrations of 100 mg/L free chlorine. The pH of the washing solutions was adjusted to 7.1-7.3 using 1M hydrochloric acid. The treatment procedures and sample analysis were same as described for ACP treatment.

### **2.8.9 ACP treatment of wastewater effluents**

The plasma treatment of the wastewater samples was carried out in a petri-dish placed inside a polypropylene box. The polypropylene boxes were packed in high barrier polypropylene bags. Aliquots (10 ml) of wastewater samples were subjected to different doses of direct plasma treatment. System and process parameters included voltage level (60-80 kV), treatment time (0-30 min), retention time (0-10 min) and organic fat content (0.2-4 g/L). All experiments were carried out using atmospheric air as the working gas. ACP treated wastewater samples were retained by unsealing the package and storing for 0-10 min before analysis.

## **2.9 Post treatment analysis**

### **2.9.1 Determination of reactive species concentration after ACP treatment**

#### **Reactive oxygen species (ROS) measurements**

Hydrogen peroxide concentrations in plasma treated liquids were determined using oxidation of potassium iodide to iodine and spectrophotometric measurement. A standard curve of known hydrogen peroxide concentrations ( $0$ ,  $2 \times 10^{-4}\%$ ,  $3 \times 10^{-4}\%$ ,  $5 \times 10^{-4}\%$ ,  $1 \times 10^{-3}\%$ ,  $2 \times 10^{-3}\%$ ,  $3 \times 10^{-3}\%$ , and  $5 \times 10^{-3}\%$  ( $1\% = 0.3263\text{M}$ ) was included on each plate and used to convert absorbance into peroxide concentrations. Briefly, 50  $\mu\text{l}$  of plasma treated liquid/standard curve samples, 50 $\mu\text{l}$  of phosphate buffer (10 mM) and 100  $\mu\text{l}$  of potassium iodide (KI; 1M) was added to 96 well microtiter plate. After 20 min incubation at room temperature absorbance was measured at 405 nm (Boehm *et al.*, 2017).

#### **Intracellular reactive oxygen species (ROS) measurements**

Measurement of reactive oxygen species (ROS) generated in the ACP treated bacterial suspension was performed utilising the 2', 7'-dichlorodihydrofluorescein diacetate (DCFH-DA) assay. DCFH-DA is a non-fluorescent cellular probe which turns highly fluorescent 2', 7'-dichlorodihydrofluorescein (DAF) upon oxidation by ROS and other peroxides which

directly correlates to ROS concentration (Gomes *et al.*, 2005). After ACP treatment and storage, *L. monocytogenes* EGD-e and knockout mutants were incubated with DCFH-DA (Sigma-Aldrich, Arklow, Ireland) at the final concentration of 5  $\mu$ M in PBS for 15 min at 37 °C under dark conditions. After incubation, aliquots of each sample was transferred to 96-well plates and the fluorescence was measured on Synergy™ HT Multi-Mode Microplate Reader (BioTek Instruments Inc., Winooski, USA) at excitation and emission wavelengths of 485 and 525 nm. Untreated control of each sample was used to determine the original intracellular ROS before ACP treatment. The data generated represent the ROS concentrations generated after ACP treatment expressed as arbitrary fluorescence units (AFU).

#### **Reactive nitrogen species (RNS) measurements**

Nitrite (NO<sub>2</sub>) concentrations were determined using Griess reagent (Sigma-Aldrich, Arklow, Ireland). A total of 50  $\mu$ l of Griess reagent was added to 50  $\mu$ l of plasma treated liquid. After 30 min of incubation, absorbance was read at 548 nm and compared to a sodium nitrite standard curve. A range of known concentration of sodium nitrite (0, 40, 50, 60, 80, 100, 200, 300  $\mu$ M) was used to prepare NO<sub>2</sub> calibration curve and to convert absorbance into NO<sub>2</sub> concentrations.

Nitrate (NO<sub>3</sub>) concentrations were assessed by 2,6-dimethyl phenol (DMP) using the Spectroquant® nitrate assay kit (Merck Chemicals, Darmstadt, Germany) using the manufacturer's instructions with minor modification. Samples were pre-treated with sulfamic acid to eliminate nitrite interference. Set of standard concentrations of sodium nitrate (0, 0.1, 0.2, 0.5, 1, 2, 4, and 5 mM) was prepared to make a NO<sub>3</sub> standard curve. Briefly, 200  $\mu$ l of reagent A, 25  $\mu$ l of treated sample and 25  $\mu$ l reagent B was added into a microtube and incubated for 20 min. After incubation period, 100  $\mu$ l of the total mixture was added to fresh 96 well plate microtiter plate and absorbance was read at 340 nm.

## **Ozone measurements**

Dissolved ozone concentration in plasma treated water was measured by the indigo method as described in Bader and Hoigne (1981). Ozone concentration was measured spectrophotometrically by the decolourisation of indigo trisulfonate. Samples of 1 ml each were withdrawn at 0, 20, 40, 60, 80 and 120 s into cuvette and absorbance was measured at 600 nm using UV-Vis spectrophotometer (Shimadzu UV 1800, Shimadzu Scientific Instruments).

Ozone and carbon monoxide concentrations inside the sealed packages containing the lamb sample were measured using Gastec ozone and carbon monoxide detection tubes (Gastec Corporation, Japan). The reagent inside the tube shows colour change upon contact with the specified gas and is calibrated for specific sampling volumes. Each measurement was taken immediately after plasma treatment, after 1 h and 24 h of post-treatment storage.

### **2.9.2 ACP treated liquids**

Plasma treated samples (PBS or 3 % BE or LB) were serially diluted in Maximum recovery diluent (MRD, Scharlau Chemie, Barcelona, Spain) and aliquots (1 ml and 0.1 ml) of appropriate dilutions were surface plated on TSA except TSA+0.01M CaCl<sub>2</sub> for *B. thermosphacta*. The plates were incubated aerobically for 24 h. To detect further possible increase in the formation of visible colonies, the plates were further incubated for 24 h. Results were represented in the form of Log<sub>10</sub> CFU/ml.

### **2.9.3 Bacterial biofilm on abiotic surface**

Biofilm formation capacity for both mono and mixed bacterial biofilm was quantified using the crystal violet assay while the antibacterial effect of applied ACP treatment on bacterial biofilm was quantification by plate count (PC) and XTT (2,3-bis (2-methoxy-4-nitro-5-sulfophenyl) [phenyl-amino)car-bonyl]-2H-tetrazolium hydroxide, Sigma Aldrich, Ireland) assay.

### **2.9.3.1 Crystal violet (CV) assay**

Crystal violet assay was performed as described in Stepanović *et al.* (2000) with minor modifications. After biofilm formation, the wells were rinsed and dried as described in section 2.4. The adherent biofilms were fixed with 200 µl methanol (99%) for 15 min, after which the supernatant was removed and allowed to air dry. The biofilms were then stained with 0.1% crystal violet stain for 20 min. Excess stain was removed by washing the wells with 200 µl of deionised water until entire water was clear. The plate was dried by gently tapping the plate on dry tissues. The dye bound cells were re-solubilised with 200 µl of 33% (v/v) glacial acetic acid and the optical density (OD) of each well was measured at 590 nm using microtiter plate reader (Synergy HT, Biotek Instruments Inc.). Each biofilm well absorbance value was corrected by subtracting the means of absorbance of a blank (uninoculated) broth (negative control). The classification system of Stepanović *et al.* (2000) was used to compare the biofilm development under different conditions.

### **2.9.3.2 Plate count assay**

Following the ACP treatment and post storage period, the bacterial biofilm in 96 well plate was re-suspended in 200 µl of sterile PBS. In order to disrupt the adhered biofilm, the plate was sonicated (Bransonic 5510E-MT, Danbury, USA) for 5-7 min. The obtained cell suspension was pooled in sterile microtubes and vortexed thoroughly to ensure separation of aggregated and clumped cells. The cell suspensions obtained from monoculture biofilms were serially diluted in sterile MRD and plated on TSA except *B. thermosphacta* which was plated on TSA + 0.01M CaCl<sub>2</sub>. The *B. thermosphacta* plates were incubated at 26 °C, *E. carotovora* and *P. fluorescens* at 30 °C, *S. enterica*, *E. coli* and *L. monocytogenes* at 37 °C for 24-48 h. The survival bacterial population obtained were represented in Log<sub>10</sub> CFU/ml. The plates with no growth were further incubated until 72 h and checked for the presence of colonies every 24 h.

To evaluate the individual contribution of bacterial species in mixed culture biofilms, the bacterial biofilm suspensions were diluted ten folds in MRD and plated on appropriate selective media plates: Sorbitol MacConkey agar (SMAC, Scharlau Chemie, Barcelona, Spain) supplemented with Cefixime-Tellurite (CT, Oxoid Ltd, England, UK) for *E. coli*, Polymyxinacriflavine- LiCl-ceftazidime-aesculin-mannitol PALCAM (Scharlau Chemie, Barcelona, Spain) supplemented with PALCAM Listeria Selective Supplement (Oxoid Ltd, England) for *L. monocytogenes*, Xylose Lysine Deoxycholate agar (XLD, Scharlau Chemie, Barcelona, Spain) for *S. enterica*, and Pseudomonas Agar Base (PAB, Oxoid, England, UK) supplemented with Cefrimide Fucidin Cephalosporin (CFC, Oxoid Ltd, England, UK) for *P. fluorescens*. Plates were incubated at appropriate incubation temperature as mentioned above for 24-48 h.

### 2.9.3.3 XTT Assay

The effect of the ACP treatment on biofilm metabolic activity was determined using the XTT assay after each ACP treatment and 24 h post treatment storage to evaluate post treatment population viability. Prior to each experiment, fresh XTT stock solution was prepared as described in Peeters *et al.* (2008). To each well, 100  $\mu$ l of PBS and 100  $\mu$ l XTT solution was added and incubated in the dark for 5h at 37°C. After incubation, the supernatant from each well (100  $\mu$ l) was transferred into new microtiter plate and absorbance was recorded at 486 nm using the microtiter plate reader. The percentage of surviving bacterial population was calculated as:

$$(A_{ACP} - A_C) / A_0 \times 100\%$$

Comparing the absorbance of treated samples ( $A_{ACP}$ ) with absorbance of the negative control ( $A_C$ ; sterile broth without inocula) and untreated control biofilms ( $A_0$ ), respectively.

#### **2.9.4 ACP treated meat sample**

To quantify the effects on lamb, approximately 10 g of the lamb was sampled using a sterile forceps and a scalpel, transferred to a stomacher bag (BA6041, Seward LTD, West Sussex, UK) with the addition of 10 ml of sterile MRD and stomached for 2 min. Subsequent dilutions were made in MRD and were surface plated on selective media STAA agar (streptomycin-sulphate, thallos-acetate and actidione, Oxoid CM881, England, UK) with STA selective supplement (Oxoid SR0151, England, UK). All the plates were incubated aerobically at 26 °C for 24-48 h and the result were reported as Log<sub>10</sub> CFU/ml. Surviving background microflora (aerobic mesophilic bacteria) isolated from raw lamb was evaluated using non-selective TSA media incubated aerobically at 26 °C for 24-48 h. Replicate samples were obtained from each tray to ensure reproducibility of the experimental data and all experiments were performed in duplicate. Results are reported as Log<sub>10</sub> CFU/g with error bars representing standard deviation.

#### **2.9.5 Wastewater effluent analysis**

For microbial enumeration, the samples were taken before and after plasma treatment respectively. Control and treated samples were pooled together in sterile eppendorf tubes after their respective post treatment storage time and were serially diluted in MRD. Subsequent dilutions were surface plated on appropriate media: TSA for *E. coli* and *B. megaterium* endospores, BHIA for *E. faecalis* and RCA for *C. perfringens*. The bacterial inactivation levels were determined by plotting Log<sub>10</sub> CFU/ml of survival bacteria against the treatment time (s) for each experimental organism. While the surviving population of mixed culture bacteria in effluent after ACP treatment was determined by plating on appropriate selective medium for each bacteria; cefixme-tellurite sorbital MacConkey (CT-SMAC, Biokar Diagnostics, Allonne, France) agar for *E. coli* O157:H7, Membrane enterococcus Slanetz and Bartley agar, modified (mEI agar, Oxoid Ltd, England, UK) for *E. faecalis* and

modified Tryptose Sulphite Cycloserine Agar (mTSC, Biokar Diagnostics, Allonne, France) with D-cycloserine supplement (Biokar Diagnostics, Allonne, France) for *C. perfringens*. All plates were incubated at 30-37 °C for 24 h. The plates were incubated for additional 24 h to observe any subsequent increase in visible colonies.

#### **2.9.7.1 Aquatic Biomarker Cytotoxicity assays**

For cytotoxicity test, individual wells of 96-well microplate were seeded with 100µl of cell suspension at seeding density of  $2 \times 10^5$  cells per ml of RTG-2 cells and  $1 \times 10^5$  cells per ml of PLHC-1 cells and were allowed to attach for 24 h exposure period. The treated effluents were filtered sterilised using 0.2 µm filters, before subjection to toxicity testing. Effluent concentrations (5, 10, and 20%) were prepared in respective supplemented DMEM media. After 24 h of cell attachment, the cells were washed with PBS and exposed to different concentration of test ACP concentrations. Six replicate wells were used for each control and ACP test concentrations per microplate. Untreated samples were used as reference control. Cytotoxicity test was assessed using Alamar blue (AB) and Neutral red (NR) assay which was conducted on the same plate following the methodology as previously described by Davoren and Fogarty (2006).

#### **2.9.7.2 Aquatic Biomarker eco-toxicological analysis using *Daphnia magna* acute**

##### **immobilisation test**

Acute toxicity tests were performed with the ACP treated effluents in accordance with the OECD test 202 Guidelines. *Daphnia magna* was kindly supplied by FOCAS research Institute cultured in static conditions at 21 °C and under a 16 h/8 h light /dark photoperiod for all exposures. Toxicity tests were performed on *D. magna* neonates that were less than 24 h old. Concentrations of ACP (5 and 10 min) treated effluents was set to 2, 5, 10, 20% using Elendt M4 *Daphnia* medium. Three replicates were tested for each test and control samples and 5 neonates were used for each replicate. Immobilisation of neonates was determined



visually after 24 h and 48 h of exposure; any abnormalities or signs of stress were also recorded. The results obtained were used to calculate EC<sub>50</sub> values i.e. effective concentration at which 50% of exposed neonates die (Casado *et al.*, 2013).

## **2.10 Statistical analysis**

Statistical data analysis was performed using SPSS 22.0 (SPSS Inc., Chicago, USA). Each experiment was repeated in duplicates and are represented as mean value with standard deviation (SD). The mean values were compared according to Fisher's Least Significant Difference (LSD) method. The survival bacterial populations were analysed by one-way variance (ANOVA) to test statistical significance among treatments. Statistical significance was accepted at  $p < 0.05$ .

For biofilm studies: statistical analysis was performed using IBM SPSS statistical tool 23.0 software (SPSS Inc., Chicago, USA). Means were compared according to the method of Fisher's Least Significant Difference at the 0.05 level.

For fresh produce studies: each experiment was repeated three times. Mean bacterial counts between various treatment groups and controls were compared using a one-way ANOVA using GraphPad Prism 5 (GraphPad software, La Jolla California USA). Differences among the treatments were performed using Tukey pairwise comparison test. Results were considered significant at  $p \leq 0.05$ .

For *Listeria monocytogenes* mutant studies: Statistical analysis was performed using SPSS 22.0 (SPSS Inc., Chicago, U.S.A). All microbial data were pooled and average values and standard deviations determined. Significant differences between samples tested were determined by using either t-test or one-way analysis of variance (ANOVA) using Fisher's Least Significant Difference-LSD at the 0.05 level. Error bars indicating standard deviations from the means are displayed on graphs and tables.

For wastewater effluents: each experiment was performed in triplicate (three independent exposures) to ensure reproducibility. The experimental data was analysed by two-way ANOVA using IBM SPSS 22.0 (SPSS Inc., Chicago, USA). For the inactivation kinetics studies between bacterial strains, two variance analyses were performed using t-test variance test. For all cell assay (AB/NR assay) fluorescence as fluorescence unit (FUs) was measured using the microplate reader. Cytotoxicity was expressed as mean percentage inhibition relative to unexposed control values, which was calculated using the formula  $[100 - (\text{mean experimental data} / \text{mean control data} \times 100)]$ . The cytotoxicity of the control sample was set to 0%. Statistical analysis and curve fitting were performed to calculate the EC<sub>50</sub> values using a nonlinear-regression sigmoidal dose-response curve model provided by Prism 5.0 software (GraphPad Software, Inc., La Jolla, CA, USA). The EC<sub>50</sub> values are reported  $\pm 95\%$  Confidence Intervals.

## **Chapter 3 Controlling *Brochothrix thermosphacta* as a spoilage risk using in-package ACP**

*B. thermosphacta* is a key spoilage microorganism of meat and its control in processing environments is important to maintain meat product quality. This study ascertained the potential of dielectric barrier discharge atmospheric cold plasma (DBD-ACP) for control of *B. thermosphacta*, in response to key parameters such as treatment time, voltage level, interactions with media composition and post treatment storage conditions. In-package treatment provides the dual advantages of mitigating against recontamination or cross contamination events within processing and compatibility with the widely applied meat preservation technology of modified or controlled atmosphere packaging. Thus, this study investigated interactions of plasma discharging in modified atmosphere packaged (MAP) meat samples to ascertain if this provides a processing advantage for microbial reduction and control.

### **3.1 Effect of the plasma treatment time and post storage time on ACP inactivation efficiency against planktonic cells of *B. thermosphacta***

A contained atmosphere post treatment storage interval was found to control inactivation. The bacterial inactivation after ACP treatment with 1 h and 24 h post treatment storage time (PTST) is represented in **Figure 3.1**. With 24 h PTST, plasma treatment at 80 kV reduced the bacterial population in stationary phase by 5 Log cycles within 15 s of plasma treatment. No cells were detected after 30 s and 60 s treatment time. Reducing post treatment storage time to 1 h, plasma treatment at 80 kV for 30 s reduced bacterial cells by 1.5 Log cycles, but no cells were detected after increasing treatment time to 60 s. Limit of detection was 1.0 Log<sub>10</sub> CFU/ml.

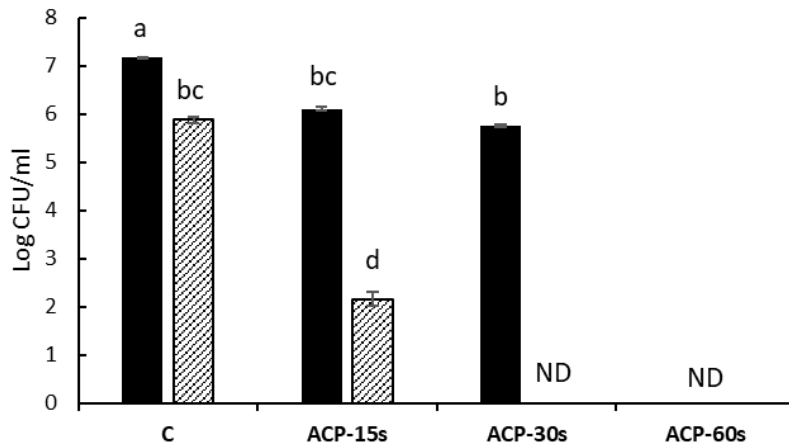

**Figure 3.1: Effect of plasma treatment on stationary phase-*B. thermosphacta* in PBS at 80 kV with (■) 1 h and (▨) 24 h post treatment storage time (PTST) with treatment time of 15 s, 30 s and 60 s.**

**C: Untreated Controls, ND: non-detectable (below detection limit of 1 Log<sub>10</sub> CFU/ml), Different letters indicate a significant difference at the 0.05 level between PTST and treatment times. Vertical bars indicate standard deviation.**

Previous studies have showed the dependency of microbial inactivation on the voltage levels (Han *et al.*, 2014). The interaction of voltage level and treatment duration period along with post treatment storage interval were investigated here for *B. thermosphacta* (**Table 3.1**). With a 24 h post storage interval, ACP treatment at 60 kV & 70 kV for 15 s showed reductions of 2.56 Log<sub>10</sub> CFU/ml and 3.64 Log<sub>10</sub> CFU/ml of bacterial populations. A maximum reduction of 5 Log cycles was observed with 15 s of ACP treatment at 80 kV. While with 1 h storage, a reduction of 1.5±0.5 Log<sub>10</sub> CFU/ml was observed with 30 s of plasma exposure at 70 kV and 80 kV. The bacterial population was undetectable after 60 s of treatment with all storage times and voltage levels except 60 kV voltage treatment with 1 h post treatment storage. However, the effect of ACP was clearly observed after 300 s of treatment. Greater inactivation was observed with increasing voltage and post treatment storage time, therefore 80 kV of applied voltage and 24 h PTST was used for further analysis in this study.

**Table 3.1: Effect of ACP on *B. thermosphacta* inactivation in PBS at different voltage levels after 1 h and 24 h PTST**

Applied voltages	Plasma treatment time (s)	1 h post storage		24 h post storage	
		cell density (log <sub>10</sub> CFU/ml)	SD	cell density (log <sub>10</sub> CFU/ml)	SD
60 kV	0	7.18 <sup>a</sup>	0.02	7.10 <sup>h</sup>	0.06
	15	6.95 <sup>b</sup>	0.04	4.56 <sup>i</sup>	0.12
	30	6.54 <sup>c</sup>	0.06	ND <sup>g</sup>	0.0
	60	6.21 <sup>d</sup>	0.11	ND <sup>g</sup>	0.0
	120	4.99 <sup>f</sup>	0.18	ND <sup>g</sup>	0.0
	300	ND <sup>g</sup>	0.0	ND <sup>g</sup>	0.0
70 kV	0	7.18 <sup>a</sup>	0.02	7.10 <sup>h</sup>	0.06
	15	6.52 <sup>c</sup>	0.12	3.46 <sup>j</sup>	0.12
	30	5.81 <sup>e</sup>	0.04	ND <sup>g</sup>	0.0
	60	ND <sup>g</sup>	0.0	ND <sup>g</sup>	0.0
	120	ND <sup>g</sup>	0.0	ND <sup>g</sup>	0.0
	300	ND <sup>g</sup>	0.0	ND <sup>g</sup>	0.0
80 kV	0	7.18 <sup>a</sup>	0.02	7.10 <sup>h</sup>	0.06
	15	6.12 <sup>d</sup>	0.05	2.17 <sup>k</sup>	0.14
	30	5.76 <sup>e</sup>	0.03	ND <sup>g</sup>	0.0
	60	ND <sup>g</sup>	0.0	ND <sup>e</sup>	0.0
	120	ND <sup>g</sup>	0.0	ND <sup>g</sup>	0.0
	300	ND <sup>g</sup>	0.0	ND <sup>g</sup>	0.0

**SD: Standard deviation; ND: under detection limit (<1.0 Log<sub>10</sub> CFU/ml). Different letters indicate a significant difference at the 0.05 level between plasma treatment times, voltage levels and post treatment storage time.**

### **3.2 The effect of nutritive environments on inactivation of *B. thermosphacta***

The inactivation of *B. thermosphacta* was investigated in a meat model medium (**Table 3.2**). In order to replicate similar nutrient conditions as in actual meat, plasma treatment was performed in liquid meat model which was composed of 3% beef extract. Samples were treated with direct plasma discharge at 80 kV with 24 h post treatment storage period at 26 °C. Table 3.2 shows that the bacteria grown in the meat model presents a greater challenge to ACP inactivation than in PBS. The bacterial population was reduced by  $2.5 \pm 0.1 \text{ Log}_{10}$  CFU/ml in the beef extract after 300 s of treatment while complete inactivation in PBS was achieved after 30 s. A protective effect on bacteria against ACP treatment was observed with the high nutrient content meat model (3% beef extract).

**Table 3.2: Surviving numbers of stationary phase *B. thermosphacta* in PBS and 3% beef extract after ACP treatment at 80 kV and 24 h post treatment storage time.**

<b>Media</b>	<b>Plasma treatment time (s)</b>	<b>Cell density (Log<sub>10</sub> CFU/ml)</b>	<b>SD</b>
<b>3% beef extract</b>	C1	7.81 <sup>a</sup>	0.05
	C2	8.59 <sup>b</sup>	0.10
	15	8.44 <sup>bc</sup>	0.07
	30	8.27 <sup>c</sup>	0.12
	60	7.88 <sup>a</sup>	0.05
	120	7.46 <sup>d</sup>	0.07
	180	7.09 <sup>e</sup>	0.14
	300	5.49 <sup>f</sup>	0.08
<b>PBS</b>	C1	7.50 <sup>d</sup>	0.07
	C2	5.89 <sup>g</sup>	0.25
	15	2.17 <sup>h</sup>	0.14
	30	ND <sup>i</sup>	0.00
	60	ND <sup>i</sup>	0.00
	120	ND <sup>i</sup>	0.00
	180	ND <sup>i</sup>	0.00
	300	ND <sup>i</sup>	0.00

**C1: Control without storage, C2: Control with 24 h storage, SD: Standard deviation, ND: non-detectable, Different letters indicate a significant difference at the 0.05 level between media and treatment times.**

### **3.3 Adhesion and biofilm formation capacity of *B. thermosphacta***

Biofilm pose serious concerns in the meat processing industries as they are major reasons for limiting the run periods of manufacturing plants and threaten the quality of products (Chmielewski and Frank, 2003). Biofilms can be formed on food processing equipment/surfaces or on the meat product itself, offering the potential for cross-

contamination and post-production contamination. A preliminary adhesive assay was performed to evaluate the ability of *B. thermosphacta* to adhere to an abiotic surface such as a 96 well polystyrene surface plates and to study the conditions at which the bacteria were able to form biofilm. Bacteria were grown in 1.2%, 3% and 12% model meat media (beef extract) at different growth durations (section 2.4.2). The attached cells were stained with crystal violet as described in section 2.9.3.1 and then the absorbance was measured. The biofilm formation capacity of *B. thermosphacta* was classified using Stepanović *et al.*, (2000) classification system. *B. thermosphacta* displayed adhesive behaviour and developed a biofilm with increasing nutrient and incubation period (**Figure 3.2**).

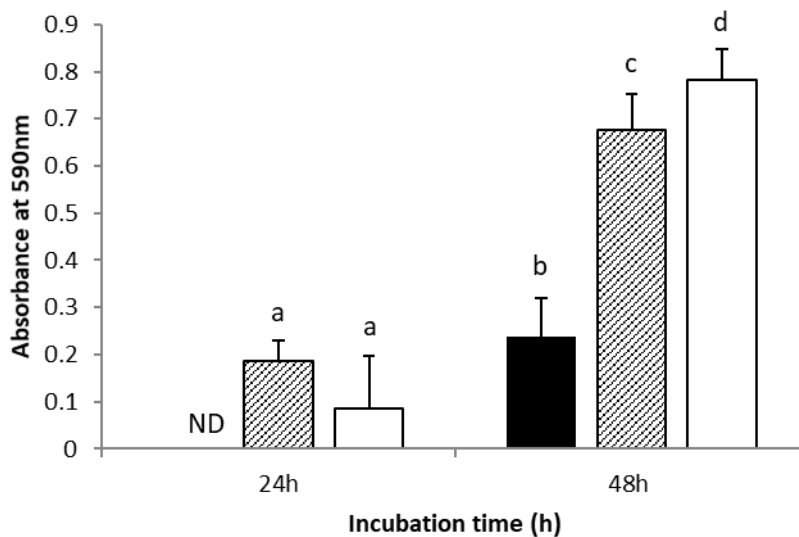

**Figure 3.2: Biofilm formation of *B. thermosphacta* after 24 h & 48 h of incubation at 26 °C quantified by crystal violet assay.**

**(■) 1.2% (▨) 3% (□) 12% beef extract media (BE). ND: Non-detectable (no biofilm formed). Vertical bars represent standard deviation.**

The biofilm formation capacity of *B. thermosphacta* was low for 24 h of incubation in both 3% BE and 12% BE, while no biofilm formation was observed in 1.2% BE. No significant difference was observed between bacterial cells attached in 3% BE and 12% BE post 24 h



incubation. The biofilm forming was increased with longer incubation of 48 h. Bacteria grown on 12% beef extract showed the highest biofilm formation after 48 h of incubation, which was confirmed by the standard plate count method. No biofilm was detected in the negative control wells which only contained culture media so as to rule out the contamination issues. These findings reflect the bacteria's ability to generate additional biofilm biomass in nutrient rich environmental conditions. Based on these results 48 h incubation period was selected for further investigation for ACP treatment.

### **3.4 Effect of ACP treatment on *B. thermosphacta* biofilms**

In order to study the efficiency of ACP to inactivate *B. thermosphacta* biofilm, bacterial biofilm grown in 12% BE for 48 h was treated at a high voltage of 80 kV for 60 s, 120s and 300s of treatment time. Surviving populations were estimated using viable cell counts (Figure 3.4a) and residual metabolic activity using XTT assay (Figure 3.4b).

Biofilm associated cells of *B. thermosphacta* was significantly reduced ( $p \leq 0.05$ ) from  $\text{Log}_{10} 8$  CFU/ml to  $4 \pm 0.6 \text{ Log}_{10}$  CFU/ml after 60 s of ACP treatment in 12% BE. Further prolonging the ACP treatment time to 120 s reduced the bacterial load to  $3 \pm 0.1 \text{ Log}_{10}$  CFU/ml; however, there was no significant difference in bacterial survival after 300 s of ACP treatment (**Figure 3.4a**).

XTT assay was carried out to find the metabolic activity of the *B. thermosphacta* biofilm immediately post ACP treatment and 24 h PTST. The percentage of biofilm survival curve based on XTT assay is represented in the **Figure 3.4b**. The ACP treatment of 80 kV for 60 s and 120 s reduced the bacterial metabolic activity by 35% and 52% respectively. However, no further reductions were observed after prolonging the treatment time to 300 s, indicating a significant retention of metabolic activity.

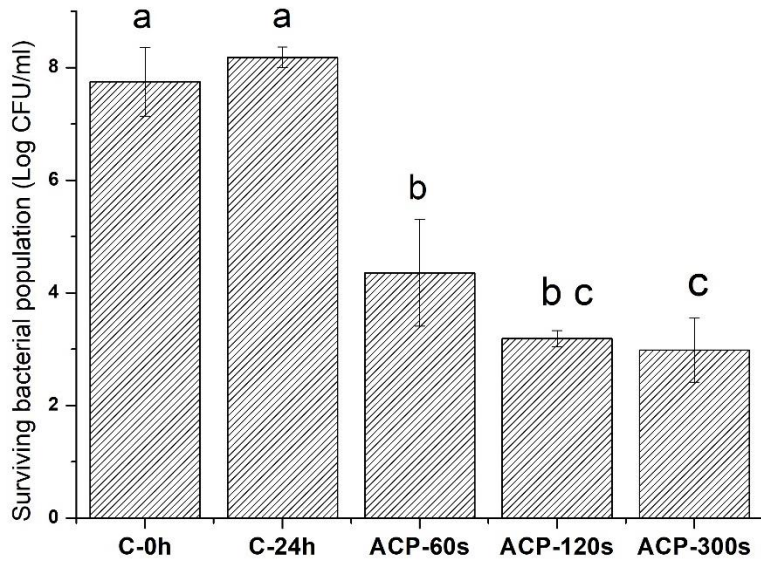

(a)

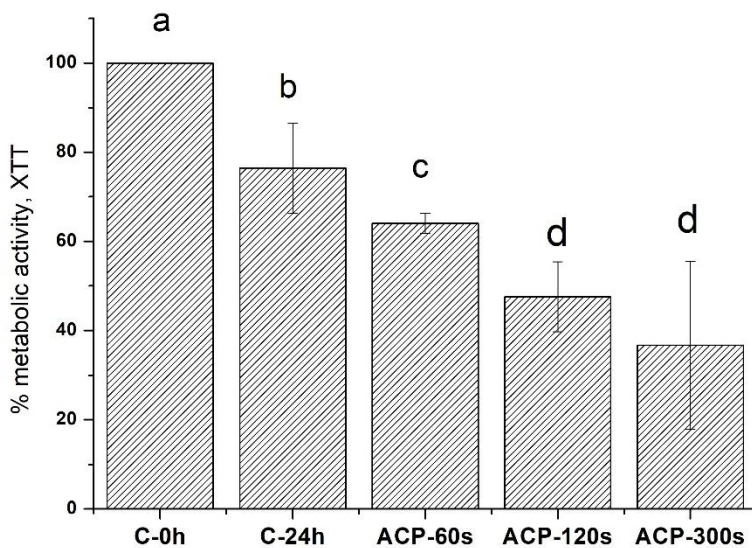

(b)

**Figure 3.3: Effect of ACP on *B. thermosphacta* 48 h biofilm formed in 12% beef extract, treated at 80 kV and assessed using (a) plate count method (b) XTT assay.**

**The limits of detection were 1 Log<sub>10</sub> CFU/ml for plating method. Vertical bars indicate standard deviations. Column with different letters indicate a significant difference bacterial biofilm and treatment times (p<0.05).**

### 3.5 In-package ACP treatment of lamb chop

Initial background microflora levels present on raw lamb chop and its reduction by ACP treatment is shown in **Figure 3.5**. The average initial concentration of background microflora on the lamb sample was approximately 6 Log<sub>10</sub> CFU/g, with no significant reductions of bacterial loads observed immediately post treatment. However, between days 7 and 10 of storage, bacterial concentrations in plasma treated samples were about 1 Log<sub>10</sub> CFU/g lower than those of untreated controls, indicating a reduced microbial growth rate. A total viable count of approx. 10<sup>7</sup> CFU/g was recorded at the end of the shelf-life study on day 13, a concentration considered in the range of borderline acceptable for MAP packed meats according to the UK Health Protection Agency (HPA, 2009). It is reported as the general threshold value for spoilage causing sensorial deterioration, such as off-odours and slime (Degirmencioglu *et al.*, 2012; Koutsoumanis *et al.*, 2008; Limbo *et al.*, 2010; Rao and Sachindra, 2002).

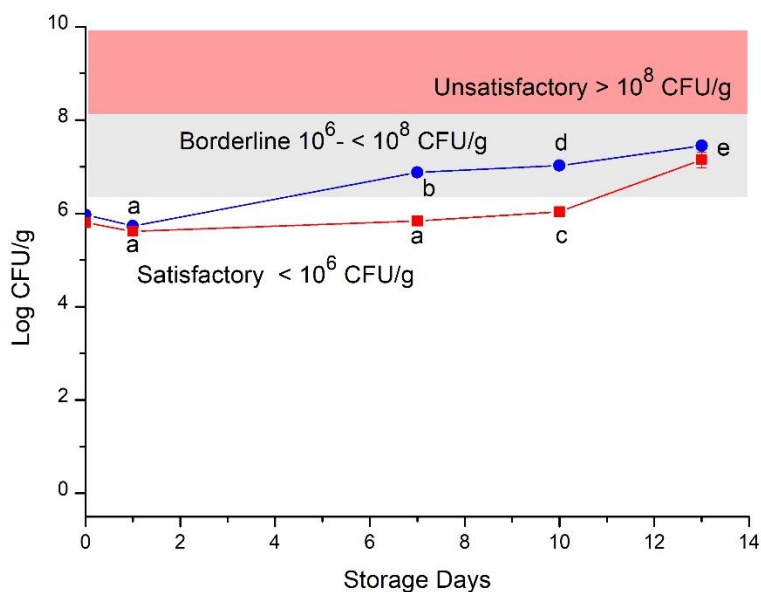

**Figure 3.4: Background microflora of lamb chop packaged with 30% CO<sub>2</sub> & 70% O<sub>2</sub> and treated with plasma at 80 kV for 60 s for shelf life of up to 13 days.**

**(●) untreated Control, (■) 60s ACP treated. Vertical bars indicate standard deviations. Column with different letters indicate a significant difference between bacterial controls and treatment time (p<0.05).**

The antimicrobial effect of in-package plasma treatment on the selected challenge spoilage organism *B. thermosphacta* inoculated on lamb was investigated. Inoculated samples were MAP packaged under high oxygen content (70%) and then treated with ACP for 1 min at 80 kV. The average initial population of the challenge bacteria attached on the meat was approximately 6 Log<sub>10</sub> CFU/g, which showed a significant 0.8 Log<sub>10</sub> CFU/ml reduction achieved immediately post treatment (p<0.05). Gradually the bacteria recovered during the storage period and an increase in bacterial concentration was observed during next 24 h (**Figure 3.6a**). A difference of 0.2-0.4 Log<sub>10</sub> CFU/ml was maintained between the control and the treated samples up to end of the storage period (p<0.05 on day 0, 4 and 7), however with longer storage periods the remaining bacterial population did grow to levels similar to the untreated samples (**Figure 3.6b**).

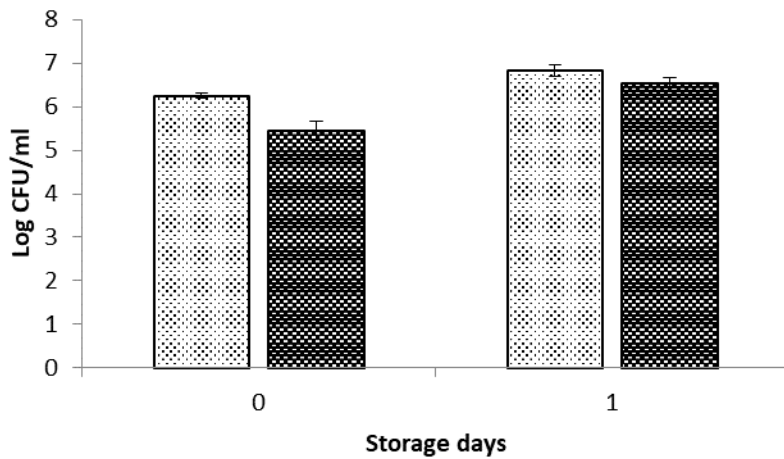

(a)

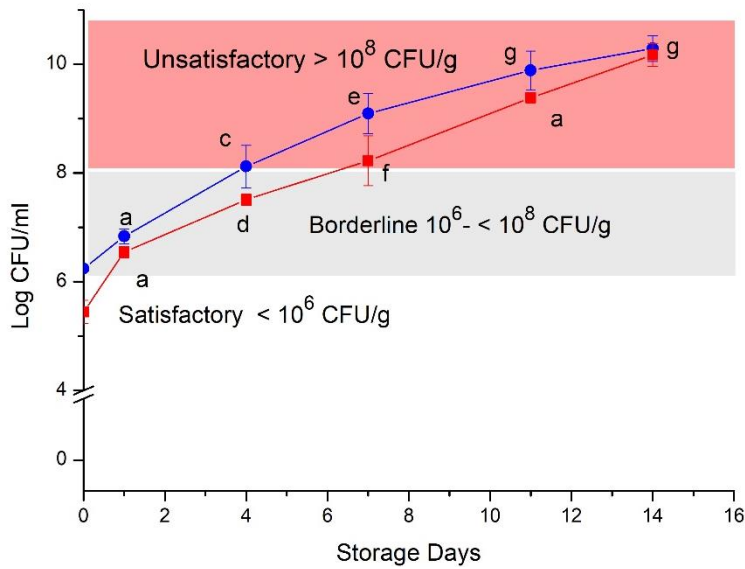

(b)

**Figure 3.5: Effect of ACP treatment (1 min at 80 kV and 24 h post treatment storage at 4 °C) on *B. thermosphacta* inoculated lamb chop packaged with 70% O<sub>2</sub> and 30% CO<sub>2</sub> concentration.**

(a) *B. thermosphacta* population on day 0 and day 1. (◻) Control (◼) ACP treated

(b) *B. thermosphacta* population in control and treated lamb for period of 14 days. (●) untreated control, (■) 60s ACP treated.

Vertical bars indicate standard deviations. Column with different letters indicate a significant difference between bacterial controls and treatment time ( $p < 0.05$ ).

Both ozone and carbon monoxide concentration were measured inside the trays immediately after treatment and after post-treatment storage (**Table 3.3**). High ozone concentrations were detected for lamb which could be attributed to the in-package headspace, thus trapping more reactive species in the package. Carbon monoxide (CO) is one of the main concerns of the meat industry due to its high toxicity and for being a meat colorant, currently banned in the 15 EU states as it stabilises the red colour and may mask visual evidence of spoilage. Undetectable levels of CO after treatment at 80 kV for 5 min were obtained, suggesting that plasma treatment of meat packaged under a modified atmosphere of 30% CO<sub>2</sub> + 70% O<sub>2</sub> gas mixture does not result in carbon monoxide concerns with none detected immediately after treatment or indeed after 1 h post treatment sealed storage. The meat volume and tray size appeared to have an important influence on the ozone generation, with large portions of meat and trays exceeding the electrode dimensions where ozone was generated in lower amounts. Further, carbon monoxide was not detected in lamb trays therefore toxicity concerns related to the potential high concentrations of carbon monoxide generated during the plasma treatment can be discarded.

**Table 3.3: In-package ozone and carbon monoxide concentration measured inside the sealed trays after plasma treatment at 80 kV**

	Measurement time		
		t=0 h	t=1 h
<b>Ozone</b>	1 min	1800 ppm	ND
	5 min	>8000 ppm	ND
<b>Carbon monoxide</b>	1 min	NT	NT
	5 min	ND	NT

ND = non-detectable; NT = not tested (if at a longer treatment time was non-detectable)

### 3.6 Discussion

*B. thermosphacta* is a predominant microflora of raw meat products (Borch *et al.*, 1996; Osés *et al.*, 2013) and is well known to cause significant impact of meat spoilage (Ercolini *et al.*, 2006). Atmospheric Cold Plasma as a novel technology can be designed for flexibility at the application point and therefore could be incorporated into food or food environment decontamination systems. Therefore, this study examined the susceptibility of *B. thermosphacta* to ACP treatment, taking microbial and food environment challenges into consideration, in response to system and process parameters. Preliminary studies demonstrated that the applied voltage level and treatment time along with PTST played a critical role in the rate of ACP inactivation against planktonic cells of *B. thermosphacta*. Higher inactivation efficiency of ACP against planktonic cells was observed with increases in applied voltage levels and treatment time. An elevation in the concentration of the reactive species (like ROS and RNS) has been reported with increases in voltage levels in association with a higher bactericidal effect (Han *et al.*, 2015; Pankaj *et al.*, 2013). The intensity of the discharge increases with increases in the voltage level and treatment time which further leads to increased amounts of reactive species. These reactive species generated are known to play an important role in bacterial inactivation, they have the ability to disrupt the bacterial cell and destroy macromolecules like DNA, proteins and lipids thus resulting in bacterial inactivation (Han *et al.*, 2014). In this study, 60 kV of ACP treatment of bacteria suspended in PBS showed a slow bacterial reduction but prolonging the treatment time to 60 s lead to complete inactivation. At 80 kV of ACP treatment, the effects were apparent with 30 s treatment time yielding inactivation below detection limits. Similar trends were observed with the previous studies of bacterial inactivation in relation to applied voltage and treatment time by Han *et al.* (2014) and Niemira *et al.* (2014). A range of post treatment storage conditions were evaluated, where 24 h of PTST was found to be most compatible for further

experiments as it allowed longer interaction between the bacteria and the reactive species thus retaining efficacy against the target.

*B. thermosphacta* biofilm growth was strong with an aggregated biofilm mass apparent in the nutrient rich conditions. These results are in agreement with other studies by Stepanović *et al.*, (2004) and Zeraik and Nitschke (2012) demonstrating strong influence of media on the surface properties of the bacteria and biofilm formation. A strong bactericidal effect in *B. thermosphacta* biofilm was observed with increasing plasma treatment time from 60 to 300 s. *B. thermosphacta* biofilms grown in 12% beef extract were found to be more resistant to plasma treatment compared to planktonic cells. Biofilm being a more complex structure than planktonic cells, protects the bacteria from antimicrobial and other unfavourable conditions. According to previous studies by Han *et al.*, 2014; Lee *et al.*, 2006 and Ulbin-Figlewicz *et al.*, 2014, Gram positive bacteria were shown to be more resistant to ACP treatment than Gram negative bacteria. The composition and thickness of the biofilm structure varies with type and strain of bacteria which significantly affects the rate of ACP inactivation. Therefore, further studies is warranted to elucidate if ACP could mitigate *B. thermosphacta* biofilm formation, either on biotic or abiotic surfaces.

The media employed also had a strong influence over the ACP bacterial inactivation, showing significant differences in the rate of bacterial inactivation when treated in PBS and model meat media. Liquid inactivation studies in meat model media showed minimum reduction of  $\pm 2.5 \text{ Log}_{10} \text{ CFU/ml}$  after 300 s of ACP treatment, while  $\pm 1 \text{ Log}_{10} \text{ CFU/ml}$  bacterial reduction were obtained in the lamb sample. The growth and survival of *B. thermosphacta* in model meat media and lamb may be attributed to the high nutrient conditions, complexity of the meat matrix and ability of the bacterial to grow in varied conditions. Previous studies by Williams *et al.*, (2005) have reported that the presence of high organic components in the medium had protective effects against the bactericidal effects of



plasma. Plasma treatment generates several reactive species which include atomic oxygen, metastable singlet state oxygen, ozone, hydrogen peroxide etc. These organic components in the media are scavengers for reactive species, which oxidize these higher organic components breaking them into intermediate products (Reszka *et al.*, 2010) and thus protecting the bacterial cells from killing (Patil *et al.*, 2009). It can also be noted that (I) the initial concentration of the challenge bacteria inoculated or present as background on the meat sample was higher than generally found on meat in industry, (II) the time-lapse between slaughter and MAP packaging as meat were purchased from local retail shop may have further contributed to the early meat spoilage.

Thus, the overall results reported here indicate that ACP has good potential to be an alternative safe decontamination process in meat industry, whether for raw meat product or the related processing environment. The demonstrated challenge associated with effecting control on highly nutritive surfaces, informs the need for flexibility in ACP treatment applications particularly to foods themselves, where repetitive or pulsed treatment may offer advantages over single stage interventions. The simultaneous evaluation of the wide range of parameters reported here provides broad insights into decontamination or control of a major spoilage bacteria namely; *B. thermosphacta*, using ACP technology which can facilitate further scale-up and optimisation.

### **3.7 Conclusions**

In conclusion, ACP was found to be effective against planktonic and biofilm cells of *Brochothrix thermosphacta*, providing complete inactivation in PBS and reducing the bacterial load in meat model media. The results obtained showed significant influence of system treatment and particularly environmental parameters such as the complexity of target media and matrix, on the rate of bacterial inactivation. Overall, the results show the potential of high voltage in-package atmospheric cold plasma treatment in reducing spoilage bacteria

like *B. thermosphacta* on meat products and meat environments, although process optimisation is required to enhance the control of *B. thermosphacta* by ACP. This treatment method could not only help inhibit the population of spoilage bacteria but also ensure microbial safety by prolonging the shelf life of meat while maintaining food quality.

**The following paper has been published from this study:**

Patange, A., Boehm, D., Bueno-Ferrer, C., Cullen, P. and Bourke, P. (2017). Controlling *Brochothrix thermosphacta* as a spoilage risk using in-package atmospheric cold plasma. *Food Microbiology*, 66, pp.48-54. <https://doi.org/10.1016/j.fm.2017.04.002>

## **Chapter 4 Potential of atmospheric cold plasma treatment for control of bacterial biofilms on fresh produce**

Food processing industries are constantly subjected to high levels of contamination by spoilage and pathogenic bacteria. The ability of pathogens to survive and grow under processing and storage conditions, as well as the development of resistance to antibiotics and disinfectants has made it even more difficult to control their levels in food. In this study, the antimicrobial efficacy of ACP against a range of microbial populations including; planktonic cultures, monocultures (*Escherichia coli*, *Salmonella enterica*, *Listeria monocytogenes*, *Pseudomonas fluorescens*) and mixed cultures biofilms (*Listeria monocytogenes* and *Pseudomonas fluorescens*) on abiotic and biotic surfaces commonly implicated in food processing industries was investigated.

In addition to biofilm formation, bacteria species are influenced by the food components as well as the food storage conditions. Food preservation conditions such as low pH, high osmotic pressure or low temperature could be adverse for some microorganisms which could induce stress responses and enhance bacterial resistance to antimicrobial treatments. Short term exposures may alter cellular physiology and increase resistant to subsequent challenges such as food disinfection or food preservation techniques (Calvo *et al.*, 2017; Patil *et al.*, 2010; Rodriguez-Romo and Yousef, 2005). Therefore, this study investigated the influence of acid and cold stress shock on ACP inactivation as well as the effect of different temperature storage conditions on biofilm formation for fresh produce and its inference on ACP antimicrobial efficacy.

### **4.1 Effect of critical control parameters on ACP inactivation efficiency**

Preliminary experiments were performed investigating the process parameters in terms of their antimicrobial effects on key microorganisms associated with food contamination and optimising the conditions to obtain high ACP efficiency. The study evaluated the effect of

high voltage levels (60, 70, 80 kV) on antimicrobial efficacy of ACP with a PTST of 24 h against stationary phase *S. enterica*, *L. monocytogenes*, *P. fluorescens* and *E. carotovora* in PBS (**Table 4.1**). The highest voltage level of 80 kV showed significantly greater inactivation by comparison to 60 kV or 70 kV ( $p < 0.05$ ). ACP treatment at 70 kV reduced *S. enterica* and *P. fluorescens* counts by  $2.3 \pm 0.10$  and  $3.0 \pm 0.06$  Log<sub>10</sub> CFU/ml after 120 s of treatment while complete inactivation was achieved using 80 kV voltage level. *L. monocytogenes* and *E. carotovora* was reduced by  $3.6 \pm 0.17$  Log<sub>10</sub> CFU/ml and  $2.36 \pm 0.02$  Log<sub>10</sub> CFU/ml after 60s of ACP exposure at 60 kV, but again was more susceptible to the higher voltage levels.

**Table 4.1: Effect of voltage on plasma inactivation efficacy in PBS**

Applied voltages	Plasma treatment time (s)	<i>S. enterica</i>		<i>L. monocytogenes</i>		<i>P. fluorescens</i>		<i>E. carotovora</i>		<i>E. coli</i>	
		Cell density (Log <sub>10</sub> CFU/ml)	SD	Cell density (Log <sub>10</sub> CFU/ml)	SD	Cell density (Log <sub>10</sub> CFU/ml)	SD	Cell density (Log <sub>10</sub> CFU/ml)	SD	Cell density (Log <sub>10</sub> CFU/ml)	SD
60 kV	C1	8.06 <sup>a</sup>	0.02	7.29 <sup>a</sup>	0.04	7.50 <sup>a</sup>	0.06	8.06 <sup>a</sup>	0.05	7.90 <sup>a</sup>	0.10
	C2	8.14 <sup>b</sup>	0.04	6.84 <sup>b</sup>	0.10	8.09 <sup>b</sup>	0.12	7.90 <sup>a</sup>	0.10	8.00 <sup>a</sup>	0.04
	30	7.38 <sup>c</sup>	0.05	6.32 <sup>c</sup>	0.09	6.30 <sup>c</sup>	0.09	6.30 <sup>b</sup>	0.09	7.80 <sup>a,b</sup>	0.19
	60	6.97 <sup>f</sup>	0.11	3.71 <sup>e</sup>	0.17	6.00 <sup>c</sup>	0.02	5.70 <sup>c</sup>	0.02	7.58 <sup>b</sup>	0.09
	120	5.69 <sup>i</sup>	0.18	ND <sup>f</sup>	-	5.70 <sup>e</sup>	0.17	4.70 <sup>d</sup>	0.17	6.82 <sup>c</sup>	0.03
	300	ND <sup>j</sup>	-	ND <sup>f</sup>	-	ND <sup>g</sup>	-	ND <sup>e</sup>	-	3.94 <sup>d</sup>	0.08
70 kV	C1	8.40 <sup>a</sup>	0.04	7.29 <sup>a</sup>	0.06	7.50 <sup>a</sup>	0.06	8.06 <sup>a</sup>	0.06	7.90 <sup>a</sup>	0.10
	C2	8.30 <sup>b</sup>	0.12	6.84 <sup>b</sup>	0.02	8.09 <sup>b</sup>	0.12	7.90 <sup>a</sup>	0.02	8.00 <sup>a</sup>	0.04
	30	6.95 <sup>d</sup>	0.05	5.30 <sup>d</sup>	0.06	6.0 <sup>c</sup>	0.10	7.00 <sup>f</sup>	0.01	7.20 <sup>e</sup>	0.05
	60	6.30 <sup>g</sup>	0.18	ND <sup>f</sup>	-	5.8 <sup>e</sup>	0.01	5.30 <sup>g</sup>	0.06	6.85 <sup>c</sup>	0.11
	120	5.68 <sup>i</sup>	0.10	ND <sup>f</sup>	-	4.50 <sup>f</sup>	0.06	ND <sup>e</sup>	-	4.23 <sup>f</sup>	0.13
	300	ND <sup>j</sup>	-	ND <sup>f</sup>	-	ND <sup>g</sup>	-	ND <sup>e</sup>	-	ND <sup>g</sup>	-
80 kV	C1	8.19 <sup>a</sup>	0.02	7.29 <sup>a</sup>	0.05	7.50 <sup>a</sup>	0.06	8.06 <sup>a</sup>	0.05	7.90 <sup>a</sup>	0.10
	C2	8.04 <sup>b</sup>	0.05	6.84 <sup>b</sup>	0.14	8.09 <sup>b</sup>	0.12	7.90 <sup>a</sup>	0.14	8.00 <sup>a</sup>	0.04
	30	6.69 <sup>e</sup>	0.02	5.00 <sup>d</sup>	0.10	6.1 <sup>c</sup>	0.20	7.30 <sup>h</sup>	0.01	7.15 <sup>e</sup>	0.10
	60	5.79 <sup>h</sup>	0.03	ND <sup>f</sup>	-	3.7 <sup>d</sup>	0.05	3.20 <sup>i</sup>	0.19	5.90 <sup>h</sup>	0.03
	120	ND <sup>j</sup>	-	ND <sup>f</sup>	-	ND <sup>g</sup>	-	ND <sup>e</sup>	-	ND <sup>g</sup>	-
	300	ND <sup>j</sup>	-	ND <sup>f</sup>	-	ND <sup>g</sup>	-	ND <sup>e</sup>	-	ND <sup>g</sup>	-

**C1: Control without storage, C2: Control with storage, SD: Standard deviation, ND: Non-detectable (below detection limit of 1.0 Log<sub>10</sub> CFU/ml), Different letters indicate significant difference between voltage levels and treatment time. Each experiment was conducted in duplicate and replicated twice.**

The effect of the contained post treatment storage time is known important process factors for microbial inactivation and is presented in **Table 4.2**. Two post-treatment storage times, 1 or 24 h, were assessed. Inactivation efficacy was related to both treatment time and post-treatment storage time. ACP treatment for 120 s with 1 h PTST reduced stationary phase *S. enterica*, *L. monocytogenes*, *P. fluorescens* and *E. carotovora* to  $1.11 \pm 0.12$ ,  $5.79 \pm 0.47$ ,  $2.72 \pm 0.2$ ,  $2.7 \pm 0.13$  Log<sub>10</sub> CFU/ml. Extending the treatment time from 120 s to 300 s while retaining the PTST at 1 h, lead to further significant reductions in population density. However, greater ACP inactivation efficiency was obtained with 24 h PTST ( $p < 0.05$ ) and 120 s treatment time, with cells below detection limit after 120 s of ACP exposure.

**Table 4.2: ACP inactivation efficacy against planktonic stationary phase bacterial populations, treated at 80 kV with different treatment and post-treatment storage times**

Bacteria	Plasma treatment time (s)	1 h Post storage		24 h Post storage	
		Cell density (Log <sub>10</sub> CFU/ml)	SD	Cell density (Log <sub>10</sub> CFU/ml)	SD
<i>E. carotovora</i>	0	8.41 <sup>a</sup>	0.05	8.41 <sup>a</sup>	0.05
	30	NT	-	7.39 <sup>e</sup>	0.01
	60	6.30 <sup>b</sup>	0.10	3.29 <sup>f</sup>	0.19
	120	5.63 <sup>c</sup>	0.13	ND <sup>d</sup>	-
	300	ND <sup>d</sup>	-	ND <sup>d</sup>	-
<i>P. fluorescens</i>	0	7.51 <sup>a</sup>	0	7.51 <sup>a</sup>	0.03
	30	NT	-	7.12 <sup>a</sup>	0.17
	60	5.81 <sup>b</sup>	0.05	3.73 <sup>c</sup>	0.05
	120	4.79 <sup>d</sup>	0.20	ND <sup>e</sup>	-
	300	ND <sup>e</sup>	-	ND <sup>e</sup>	-
<i>S. enterica</i>	0	8.03 <sup>a</sup>	0.15	8.07 <sup>a</sup>	0.04
	30	NT	-	6.69 <sup>c</sup>	0.05
	60	7.85 <sup>b</sup>	0.08	5.79 <sup>d</sup>	0.18
	120	6.92 <sup>c</sup>	0.12	ND <sup>e</sup>	-
	300	ND <sup>e</sup>	-	ND <sup>e</sup>	-
<i>E. coli</i>	0	7.00 <sup>a</sup>	0.16	7.00 <sup>a</sup>	0.06
	30	NT	-	3.62 <sup>c</sup>	0.03
	60	6.21 <sup>b</sup>	0.10	ND <sup>d</sup>	-
	120	ND <sup>d</sup>	-	ND <sup>d</sup>	-
	300	ND <sup>d</sup>	-	ND <sup>d</sup>	-
<i>L. monocytogenes</i>	0	7.30 <sup>a</sup>	0.06	7.30 <sup>a</sup>	0.06
	30	NT	-	5.00 <sup>d</sup>	0.10
	60	2.15 <sup>b</sup>	0.21	ND <sup>c</sup>	-
	120	1.51 <sup>b</sup>	0.47	ND <sup>c</sup>	-
	300	ND <sup>c</sup>	-	ND <sup>c</sup>	-

**SD: Standard deviation, ND: non-detectable, NT: Not tested. Different letters indicate a significant difference at the 0.05 level between treatment and post treatment storage times. Experiments were performed in duplicates and replicated twice. Limit of detection was 1.0 Log<sub>10</sub> CFU/ml.**

## 4.2 Effect of food and storage conditions on ACP bacterial inactivation efficiency

To investigate the effect of food product and storage conditions on ACP bacterial inactivation efficiency, mild acid and temperature stresses were applied to stationary phase *L. monocytogenes* and *P. fluorescens* inoculated in lettuce broth (model product media) and treated with ACP (**Figure 4.1**). In general, the inactivation rates for *L. monocytogenes* and *P. fluorescens* obtained from short term exposure to acid (pH 4) stress were quicker than non-stress control bacterial cells. *P. fluorescens* exposed to mild acid stress was highly sensitive and were reduced to 1.6 Log<sub>10</sub> CFU/ml after 60 s of plasma exposure. Exposure to mild cold stress (4 °C) did not significantly influence the effectiveness of ACP treatments on *P. fluorescens*; both stressed and control cells had similar inactivation patterns. However, *L. monocytogenes* exposed to low temperature, showed significantly higher resistance to ACP than the non-stressed population. Exposure to environmental stress such as acid or temperature could trigger stress responses in *L. monocytogenes* (Bergholz *et al.*, 2012; Venkitanarayanan *et al.*, 2017) thus demonstrating enhanced bacterial resistance to ACP treatment than cells not exposed to acid/temperature stress.



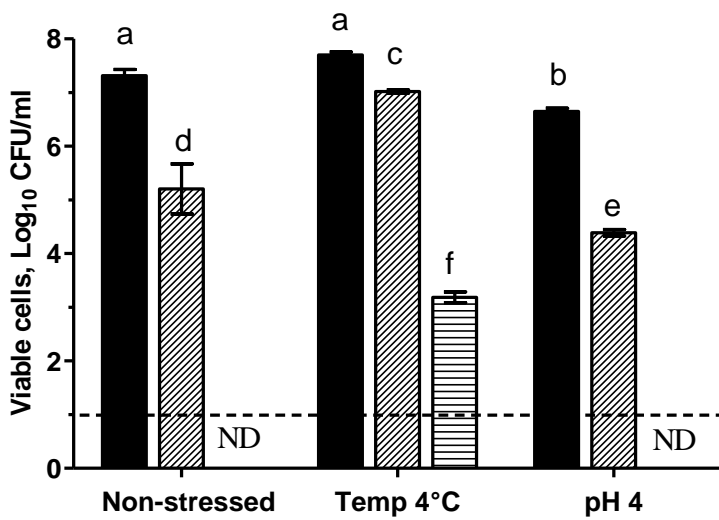

(A)

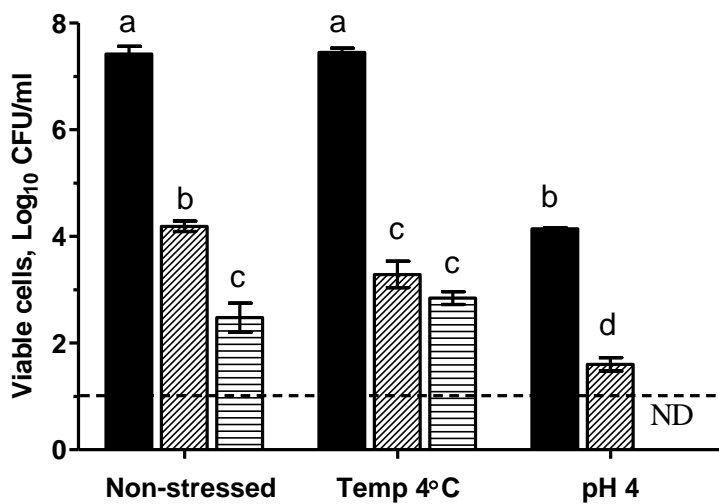

(B)

Figure 4.1: Effect of acid stress and cold shock on the resistance of (A) *L. monocytogenes* and (B) *P. fluorescens* to ACP treatment

(■) Control untreated, (▨) 60s ACP, (▩) 120s ACP when suspended in lettuce broth. ND: Non-detectable. Dotted lines indicate detection limit i.e. 1.0 Log<sub>10</sub> CFU/ml. Experiments were performed in duplicated and replicated three times (n = 6). Column with different letters indicate a significant difference between controls and ACP treated samples (p<0.05). Vertical error bar indicates standard deviation.

### 4.3 Microbial biofilm formation in lettuce broth

Biofilm formation capacity of selected microorganisms in lettuce model media was quantified using a crystal violet assay (**Figure 4.2**). According to the classification system of adherence capabilities of microbial strains described by Stepanović *et al.* (2000), *E. coli* and *L. monocytogenes* were classified as moderate biofilm formers whereas, *S. enterica* and *P. fluorescens* demonstrated to be strong biofilm formers. While *E. carotovora* formed a weak biofilm observed after 96 h of incubation (data not shown). Incubation for 48 h resulted in the highest biomass production therefore only bacterial biofilms grown for 48 h were used in further studies.

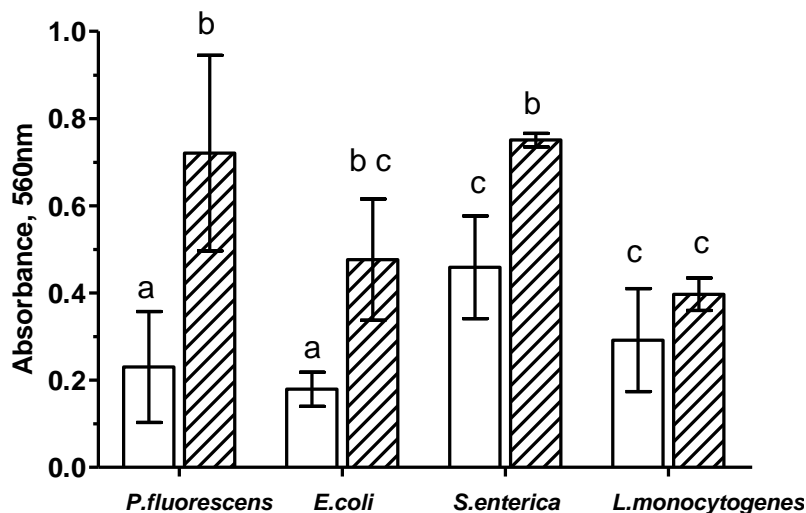

**Figure 4.2:** Bacterial biofilm formation after (□) 24 h (▨) 48 h of incubation quantified by crystal violet assay. Vertical bars indicate standard deviations. Column with different letters indicate a significant difference between bacterial strains and biofilm incubation time ( $p < 0.05$ ).

To evaluate the dual/mixed biofilm formation, different combination of bacterial cultures were grown together in lettuce broth for 24-48 h. The average absorbance obtained for dual/mixed culture biofilms in 96 well microtiter plates is illustrated in **Figure 4.3**. There were distinct differences in the biofilm biomass of dual culture biofilm of *L. monocytogenes*

and *P. fluorescens* compared to the monocultures or other bacterial combinations of mixed biofilms formed. Among all combination of strains, *L. monocytogenes* and *P. fluorescens* formed strong biofilms than rest of the strains, therefore, the study further evaluated the antibiofilm activity of ACP against mixed biofilms of *L. monocytogenes* and *P. fluorescens*.

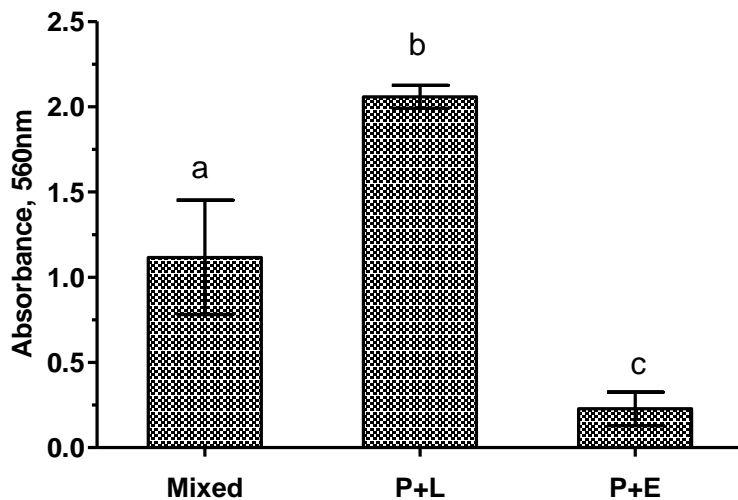

**Figure 4.3: Biofilm formation of dual/mixed culture bacteria.**

(Mixed): *L. monocytogenes*, *S. enterica*, *E. coli* and *P. fluorescens*; (P+L): *P. fluorescens* and *L. monocytogenes*; (P+E): *P. fluorescens* and *E. coli* formed for 48 h at 30 °C under static conditions. Vertical bars indicate standard deviations. Column with different letters indicate a significant difference between bacterial ( $p < 0.05$ ).

#### **4.4 Effect of ACP treatment on mono-culture bacterial biofilms**

Preliminary studies demonstrated ACP to effectively inactivate planktonic microorganisms relevant to the food environment. Inactivation of bacterial biofilms is of special interest in the food industry due to their resistance and increasing source of contamination in food products, leading to food spoilage, reducing shelf life of products, or transmission of diseases (Phillips, 2016). This study investigated the potential of ACP treatment for inactivation of bacterial biofilms formed by *E. coli*, *L. monocytogenes*, *S. enterica* and *P. fluorescens*. Since 48 h culture incubation yielded increased biomass with mature biofilms, 48 h biofilm were utilised

for the challenge biofilm inactivation studies. The impact of ACP inactivation on biofilms were analysed by plate count and XTT assay, providing insight into bacteria's culturability and metabolic activity post plasma treatment. Surviving populations of *E. coli*, *L. monocytogenes*, *S. enterica* and *P. fluorescens* 48 h old mono-culture biofilm are represented in the **Figure 4.4a and 4.4b**. Biofilm formation for 48 h in 12% lettuce broth resulted in an average attached population of  $5.4 \pm 0.4 \text{ Log}_{10} \text{ CFU/ml}$ . According to both plate count and XTT assays, significant reductions of bacterial biofilms were observed after ACP treatment. ACP treatment reductions were 3.76, 4.14 and 2.6  $\text{Log}_{10} \text{ CFU/ml}$  for *L. monocytogenes*, *S. enterica* and *P. fluorescens* respectively. The highest inactivation levels were observed for *E. coli*, where ACP treatment reduced bacterial population to undetectable levels, analysed by plate count method. However, XTT assay demonstrated the presence of 34% metabolic active biofilm cells when compared to control untreated (0 h). While, in the cases of *L. monocytogenes*, *S. enterica* and *P. fluorescens*, better correlations were observed between the colony count and XTT assay, with metabolic activity reduced by 72%, 42% and 35% respectively.

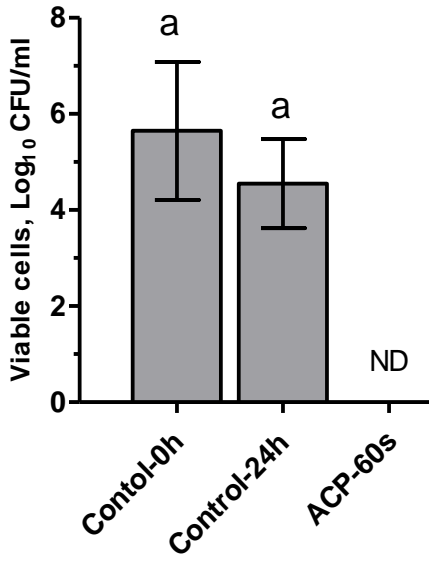

*E. coli*

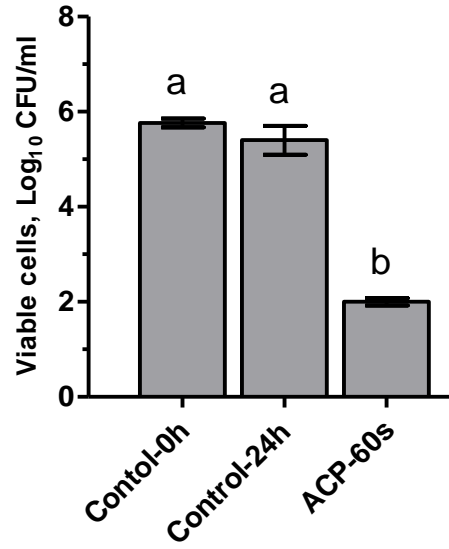

*L. monocytogenes*

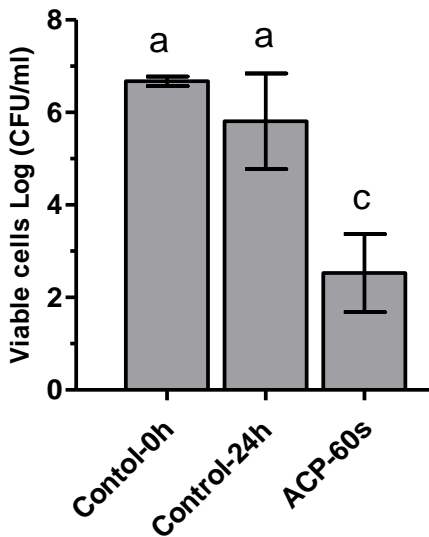

*S. enterica*

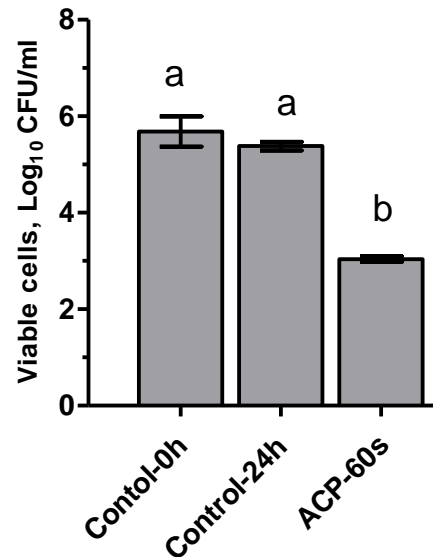

*P. fluorescens*

Figure 4.4: Surviving populations of 48 h mono-culture biofilm assessed by (a) Plate count (b) XTT assay after 60 s of ACP treatment at 80 kV and 24 h PTST.

Figure 4.4 (a) Plate count: Vertical bars represent standard deviation. Column with different letters indicate a significant difference between controls (0h & 24h) and ACP treated samples ( $p < 0.05$ ). ND: Non-detectable; Limit of detection for plate count was 1.0 Log<sub>10</sub> CFU/ml.

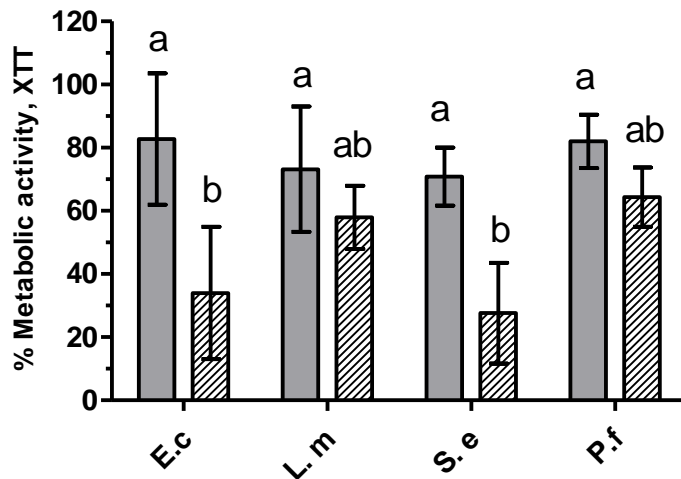

**Figure 4.4 (b): Percentage surviving populations of 48 h bacterial biofilms assessed by XTT assay. (E.c) *E. coli*, (L.m) *L. monocytogenes*, (S.e) *S. enterica* and (P. f) *P. fluorescens*; (■) untreated 24 h control (▨) ACP 60 s treated. Vertical bars represent standard deviation. Column with different letters indicate a significant difference between bacterial strains and treatment time ( $p < 0.05$ ).**

#### 4.5 Effect of ACP treatment on mixed culture bacterial biofilm

Bacterial contamination of food or food processing environment is more likely to exist as multi-species biofilms, therefore subsequent investigations focussed on a mixed species biofilm model. A significant increase in biofilm biomass was observed in mixed culture biofilm as compared to monoculture biofilms. ACP was also employed to treat mixed species biofilms to investigate their antimicrobial effects in food processing environment. **Figure 4.5** shows the size of the surviving populations as a function of duration of ACP treatment for monoculture and dual species biofilm of *L. monocytogenes* and *P. fluorescens*. In case of dual species biofilms, interspecies interaction was found to have small effect on the antimicrobial efficacy of ACP treatment. Both *L. monocytogenes* and *P. fluorescens* in dual species showed around  $4.2 \pm 0.2$  log reduction after ACP treatment of 60 s and 24 h PTST. Similar trend was observed by XTT assay, the percentage of metabolically active cells significantly decreased to an average of  $52.5 \pm 10.4\%$ ,  $23.9 \pm 2.3\%$  and  $3.5 \pm 2.4\%$  after 60 s, 120 s and 300 s of treatment. Both species under mono culture or mixed conditions were found to be sensitive to ACP treatment.

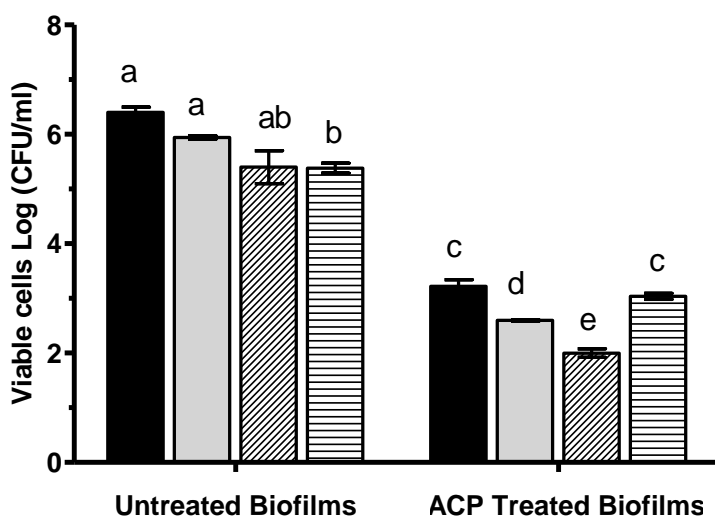

(A)

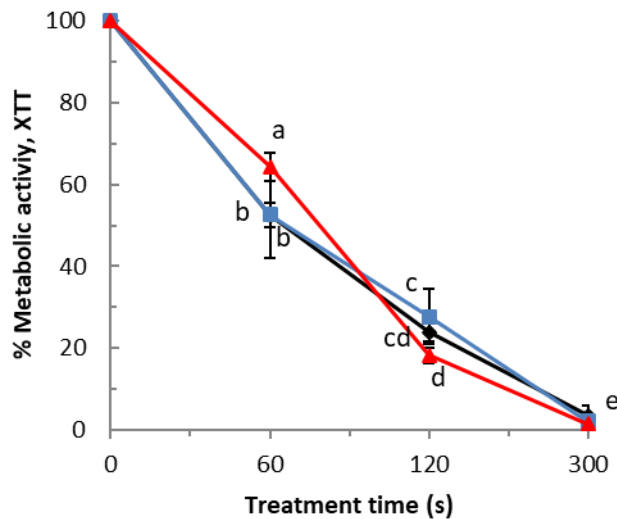

(B)

**Figure 4.5: Surviving populations of bacterial biofilms after ACP treatment at 80 kV and 24 h PTST assessed by:**

(A) Colony count assay: (■) *L. monocytogenes* dual-biofilm, (■) *P. fluorescens* dual-biofilm, (⊘) *L. monocytogenes* mono-biofilm and (⊘) *P. fluorescens* mono-biofilm.

Detection limit for plate count method was 1.0 Log<sub>10</sub> CFU/ml.

(B) XTT assay: (■) *L. monocytogenes* single biofilm, (▲) *P. fluorescens* single biofilm, (◆) dual biofilm of *L. monocytogenes* and *P. fluorescens*.

Experiments were performed in duplicate and replicated twice (n = 4). Vertical bars represent standard deviation. Column with different letters indicate a significant difference between bacterial biofilms and treatment time (p<0.05).

#### 4.6 Effect of ACP on bacterial populations inoculated on lettuce

The antimicrobial efficacy of ACP against dual bacterial biofilms of *L. monocytogenes* and *P. fluorescens* on lettuce grown at 4 °C or 15 °C is presented in **Figure 4.6**. After 5 min of treatment, the concentration of cells in 48 h biofilm formed at 15 °C were significantly reduced to undetectable levels compared with untreated controls (p ≤ 0.05).



In the current study, different inactivation patterns were observed for 48 h biofilms grown at 4 °C and 15 °C. Increased resistance to ACP treatment was observed for 48 h biofilms formed at 4 °C with 4 Log<sub>10</sub> CFU/ml reduction achieved for *L. monocytogenes* and 2.1 Log<sub>10</sub> CFU/ml for *P. fluorescens*. Even though the average initial bacterial biofilms formed by *L. monocytogenes* ( $7.0 \pm 0.3$  Log<sub>10</sub> CFU/ml) and *P. fluorescens* ( $5.5 \pm 0.2$  Log<sub>10</sub> CFU/ml) was similar at both temperatures, the biofilms grown at 4 °C were more resistant to inactivation by ACP. These findings imply that environmental stressors could influence antimicrobial efficacy of ACP treatment.

Storage temperature is an important factor in maintaining the quality and the shelf-life of the fresh products. A difference in the overall lettuce appearance was observed at lettuce stored at different refrigeration temperatures prior plasma treatment; signs of slight browning was observed only on lettuce stored at 15 °C. No difference in relation to colour or texture of lettuce were visible due to the plasma treatment and post 24 h storage. This research with lettuce stored under refrigeration and or abuse temperatures presents an opportunity to further explore the physicochemical and sensory properties of the fresh food products in future.

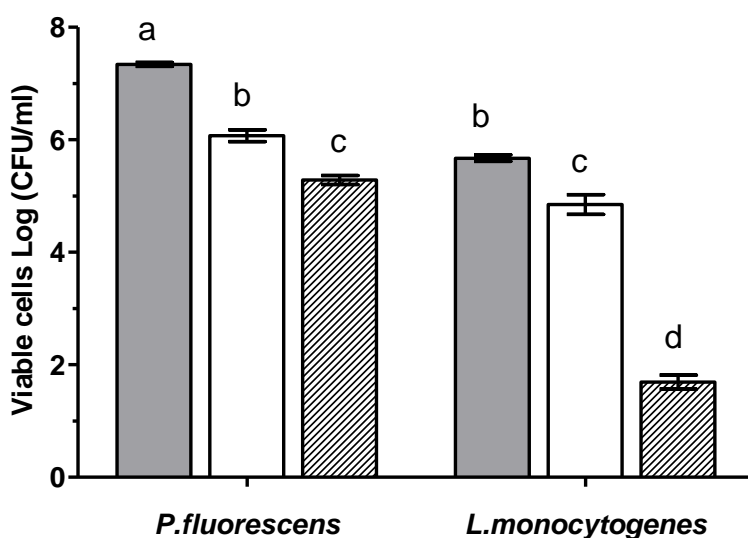

(A) 4°C

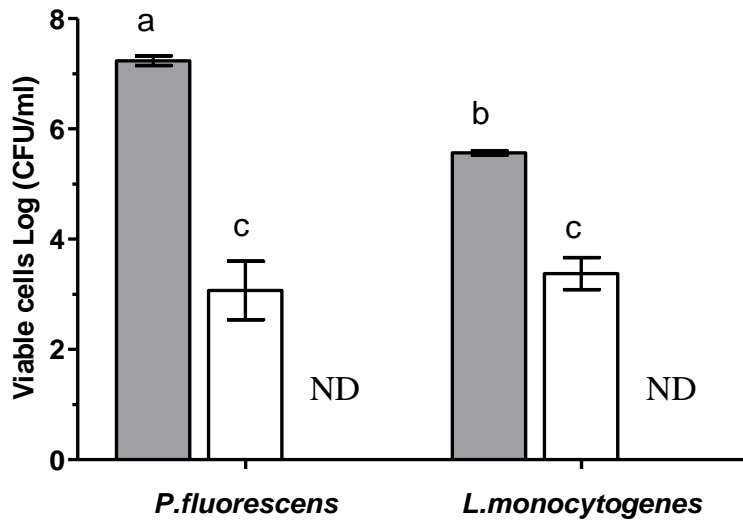

(B) 15 °C

Figure 4.6: Effect of ACP on 48 h dual bacterial biofilms of *L. monocytogenes* and *P. fluorescens* formed on lettuce at (A) 4 °C and at (B) 15 °C.

(■) untreated control, (□) 2 min and (▨) 5 min ACP treated samples. ND: not detectable; limit of detection 1.0 Log<sub>10</sub> CFU/ml. Experiments were performed in duplicate and replicated twice (n=4). Different letters indicate significant difference between bacterial biofilms and ACP treated samples (p<0.05). Vertical bars represent standard deviation.

#### 4.7 Discussion

In summary, results from this study show potential of ACP to treat both pathogenic and spoilage bacterial in mono or dual biofilms. The study demonstrates the impact of different parameters influencing ACP inactivation efficacy which includes: the bacterial type, physiological state of cells, substrate on which the bacteria are present and ACP process parameters such as voltage level and post treatment storage environment conditions.

Increasing applied voltage levels to 80kV largely resulted in higher bacterial inactivation, reaching undetectable levels within short periods of treatment time. Similar results were obtained with Han *et al.* (2016b), where the author also reported increased Reactive Oxygen

Species (ROS) levels along with increased voltage levels have resulted faster inactivation. Atmospheric air plasma are excellent sources of ROS and RNS (Han *et al.*, 2015) including ozone, hydrogen peroxide and nitrates; which are amongst the most commonly detected species using in-package Dielectric Barrier Discharge-ACP treatment (Boehm *et al.*, 2017; Han *et al.*, 2015). The reactive species generated by plasma have inhibitory effect on bacterial population causing oxidative damage of macromolecules like DNA, proteins and lipids (Bourke *et al.*, 2017). Additionally, PTST emerged as a critical treatment parameter for bacterial inactivation with this system. Reports from Niquet *et al.* (2018) established that increasing the PTST helped retain the reactive species generated from plasma treatment inside the container, increasing the diffusion and interaction time with the microbial targets sample which further enhanced antimicrobial efficacy. The study also reported high concentrations of hydrogen peroxide using the in-package DBD-ACP system which increased over post treatment storage time of 24 h (Niquet *et al.*, 2018). Similarly, the influence of storage time on plasma efficiency at short treatment durations was clearly observed in our study. The PTST of 1 h or 24 h facilitates retention of short- or long-lived reactive species that enhances the antimicrobial efficacy for decontamination. The interaction between the plasma species and bacteria has been reported (Han *et al.*, 2015; Julák *et al.*, 2012). In this study, a high voltage of 80 kV along with 24 h PTST, was efficient to reduce most of the bacterial species with short treatment times thus these parameters were used for further analysis.

To simulate real fresh produce processing conditions, a lettuce model broth was used to analyse the influence of the substrate components and storage conditions in relation to fresh produce on the antimicrobial efficacy of the treatment. It is known, most food substrates either enhance or reduce, bacterial attachment and subsequent biofilm formation (Papaioannou *et al.*, 2018). Also, foodborne microorganisms are known to encounter a

variety of stresses (acid, oxidative, cold or heat shock induced mutations) within the food chain, including production, harvest, postharvest handling, processing, disinfection and storage (Delaquis and Bach, 2012) which may increase tolerance the or resistance of bacteria. Therefore, this study investigated the influence of short-term exposure of acid or cold stress on inactivation of common food pathogen and spoilage organisms inoculated in lettuce broth by ACP. Both strains studied were sensitive to ACP post acid exposure showing significant reductions ( $p < 0.05$ ) within 120 s of plasma exposure. *L. monocytogenes* exposed to cold stress (4 °C) for 1 h resulted in a higher resistance than non-stressed control cells, potentially giving a cross-protective effect against ACP treatment. While, *P. fluorescens* exposed to cold stress (4 °C) did not show significant difference to values obtained for control non-stressed cells. *L. monocytogenes* and *P. fluorescens* both are psychrotrophic bacteria known to survive and grown under refrigeration temperatures. Microbial adaptation to stress is also known to extend the tolerance to multiple other lethal stresses, referred to as cross protection (Johnson, 2002). Microorganism can utilise cross-protection as a defence mechanism against many food disinfection or food preservation techniques (Rodriguez-Romo and Yousef, 2005). Therefore, the cold stress induced cross protection to cold plasma observed here should be taken into account when designing and implementing minimal processing regimes that rely on refrigeration temperatures.

The physiological state of the bacterial cells has been reported to play an important role in its resistance under adverse environment conditions. Several microbial pathogens or spoilage bacteria are able to form biofilm on a wide variety of surfaces which may possess a potential risk for continuous reservoir of contamination in food processing environment. In general, biofilms are the dominant life style of bacteria which can grow and survive in all environments and have enhanced resistance to several antimicrobial agents (Sanchez-Vizuete *et al.*, 2015). Fresh produce lettuce model broth was used to form biofilms on a microplate

surface to analyse the influence of substrate components in relation to fresh produces on antimicrobial efficacy of treatment. ACP treatment was effective against challenge mono species biofilms which was determined using direct plating technique combined with XTT assay to gain insight into both culturable and metabolic active cells of the bacterial biofilm. According to colony counts, treatment for 60 s reduced the *E. coli* population to undetectable levels, whereas this treatment was less effective against *L. monocytogenes*, *S. aureus* and *P. fluorescens*. The percentage reduction values based on the XTT assay showed a good correlation with the plate count method for *L. monocytogenes*, *S. aureus* and *P. fluorescens*. While in the case of *E. coli* biofilms, even though the plate count results demonstrated bacterial cell count to undetectable levels, 34% metabolically active cells were detected after 60 s of ACP exposure. This could be due to the oxidative stress encountered from reactive species generated by ACP treatment, bacteria may enter the viable but non-culturable (VBNC) state where bacteria cells are still alive but are not able to grow on bacteria media. VBNC is a strategic state adopted by most prokaryotes when subjected to adverse environmental conditions (Arana *et al.*, 2010). There was a loss of bacteria culturability but the cells were still metabolically active under stress conditions and with the adoption of VBNC phenotype they may be able to retain their virulence factors that could contribute further to contamination (Barcina and Arana, 2009; Oliver, 2010).

Interestingly in multispecies biofilm, both *P. fluorescens* and *L. monocytogenes* displayed significantly higher biofilm cells compared to its pure culture biofilm. The main proposed factor for *P. fluorescens* and *L. monocytogenes* co-operation is the EPS production, large amount of Pseudomonas EPS that would fix, embed and protect *L. monocytogenes* (Puga *et al.*, 2014). Several factors could be involved for the tolerance factor of multispecies biofilm which includes the higher extracellular polymer substance (EPS) production, differences in physiological status, interspecies cross protection among the species and internalisation into

the food (Stewart, 2015). Considering this, mixed biofilm species represent more challenging environment than single species biofilms. Previous studies by Norwood and Gilmour (2000) & Saá Ibusquiza *et al.* (2012) investigated the resistance of single and mixed species biofilms of *Listeria* and *Pseudomonas* against different chemical disinfectants. Their research demonstrated that *Listeria* and *Pseudomonas* species grown in mixed species under most conditions were more resistant to disinfectants than single species. The interspecies interactions that takes place in multi-species biofilm significantly modify the matrix complex if compared with mono-cultures. In contrast, in this study, interspecies interaction did not seem to have any effect on the antimicrobial resistance of biofilms for each individual species. A significant reduction in mixed biofilms formed by *L. monocytogenes* and *P. fluorescens* after 60 s of treatment was found complete inactivation after prolonging the treatment time to 120 s. The results obtained demonstrate that ACP treatment obstruct the association capacity between the mixed biofilms, giving rise to a mixed biofilm that is significantly ( $p < 0.05$ ) less resistant to ACP. However, when the challenge mixed culture microorganisms were inoculated onto lettuce, an extended treatment time (300 s) was necessary in order to achieve significant reduction of challenge mixed bacterial culture biofilms inoculated on lettuce for 48 h. Bacterial pathogens can rapidly attach to different plant parts (stomata, veins, lenticels, plant cuts) and persists for longer periods which are much more complex for antimicrobial treatments to reach (Warning and Datta, 2013). Also, the organic components in the fresh produces such as proteins and vitamins could scavenge the reactive species generated by the plasma exposure thus defending the microbial cells from oxidation and cell death. Additionally, studies by Ziuzina *et al.* (2015) demonstrated that the storage conditions, such as temperature, light and time have interactive effects on bacterial proliferation and susceptibility to the ACP treatment. The fluctuation in the temperature or light intensity may induce bacterial attachment, biofilm formation and internalisation in

plants (Ziuzina *et al.*, 2015). Consistent storage temperature is difficult to maintain throughout the distribution process of fresh produce. Therefore, in this work, the effect of temperature (4 °C and 15 °C) on bacterial biofilm formation and its susceptibility to ACP treatment was evaluated. The temperature 4 °C was chosen as the general refrigeration temperature used for fresh produce storage and 15 °C was selected to be close to temperature abuse conditions encountered in many food production environments. The results demonstrated that high voltage ACP treatment for 300 s significantly reduced 48 h biofilm grown at 15 °C to undetectable levels, however there was significant difference between biofilm grown at 4 °C. Mixed biofilm formed at 4 °C showed increased resistance to the treatment, *P. fluorescens* particularly was found to present higher resistance than *L. monocytogenes* to ACP treatment. Similarly, the resistance of *L. monocytogenes* exposed to with chlorine (0.465%) or peroxyacetic acid (2%) increased with incubation time of stainless steel at 4 °C (Belessi *et al.*, 2011). Furthermore, previous studies have demonstrated bacteria present in mixed species biofilm have increased understanding of interactions and dynamics of surface attachment. The bacterial populations attached may not contribute at the same level towards biofilm formation or under environmental stress conditions, some of the bacterial strain is able to dominate over the others, depending on the surrounding conditions and development of resistance (Giaouris *et al.*, 2013; Kostaki *et al.*, 2012). The more characteristic feature of the dual *L. monocytogenes* and *P. fluorescens* biofilms is the layering, *L. monocytogenes* is located at the bottom layer of the dual biofilm (Puga *et al.*, 2014). The bacterial population located at bottom in the biofilm structure undergo several anaerobic and starvation stresses (Lungu *et al.*, 2010). Depth and slow doubling time could contribute to highly increased resistance to antimicrobials as observed for *L. monocytogenes* in multispecies.

## 4.8 Conclusion

In conclusion, ACP was effective against planktonic populations effectively eliminating viable cells present in a mature biofilm formed in lettuce broth or on lettuce under different conditions (mono or mixed biofilm). ACP remains a promising technology for decontamination of pathogenic or spoilage bacteria in biofilms present fresh produce and associated food processing environments. However, caution must be used in cognisance of the environmental stresses previously encountered by the microbial risk and the potential for cross protection to ACP from low temperature exposure. All the result presented surely highlight the complexity of the mono/mixed biofilm, the influence of interspecies interaction between pathogenic and spoilage bacteria in biofilm, culture and biofilms setup conditions, temperature, substrate surface and composition of substrate. The fresh produce industry currently lacks efficient control methods to ensure elimination of food-borne pathogens from minimally processed food products. ACP could be part of an efficient control mechanism against bacterial contamination in fresh cut produce or minimally processed products which could help extend shelf-life while maintaining quality. Further investigations of the molecular mechanism behind the stress responses and the relationship to ACP treatment is needed to provide useful information for optimisation and implementation of effective ACP decontamination regimes.

### **The following paper has been published from this study:**

Patange, A., Boehm, D., Zuizina, D., Cullen, P.J., Gilmore, B., Bourke, P., 2019. High voltage atmospheric cold air plasma control of bacterial biofilms on fresh produce. *Int. J. Food Microbiol.* [doi:https://doi.org/10.1016/j.ijfoodmicro.2019.01.005](https://doi.org/10.1016/j.ijfoodmicro.2019.01.005)



## **Chapter 5 Effect of atmospheric cold plasma on bacterial stress responses and virulence**

The impact of ACP on gene expression levels of *L. monocytogenes* has not been investigated in detail to date. The present work aims to elucidate the responses of *L. monocytogenes* stress genes to ACP treatment. Nine knock out mutants of stress related genes in *L. monocytogenes*, as listed in Table 2.2, were compared with the parent strain with respect to their inactivation patterns. Further, the transcriptomic analysis was applied using RT-PCR to determine the activities of stress related genes to create a partial picture of cellular functions following ACP exposure.

### **5.1 Detection of intracellular ROS in *L. monocytogenes* after plasma treatment**

Several studies have reported that the plasma effect is mainly due to the generation of reactive species (Barekzi *et al.*, 2012; Graves, 2012). Amongst them, ROS is suggested to play an important role in the bactericidal activity. Parameters such as the plasma source, gas mixture, method of treatment and composition of the substrate medium treated affect ROS generation and plasma performance (Joshi *et al.*, 2011). In an attempt to evaluate treatment parameters influencing intracellular ROS generation, *L. monocytogenes* strains were exposed to plasma treatment for 1-5 min. As observed in **Figure 5.1**, 1 min plasma treatment significantly increased the ROS levels in both wild-type and mutant strains. The ROS levels increased in tandem with increasing treatment times in samples with post-treatment storage time of 1 h.  $\Delta gadD2$  with 1 min treatment had a much higher signal than all other mutant strains ( $p < 0.05$ ). After 5 min treatment, higher ROS levels were observed from  $\Delta gadD2$ ,  $\Delta gadD2D3$  and  $\Delta sigB$  than the wild strain and other mutants.

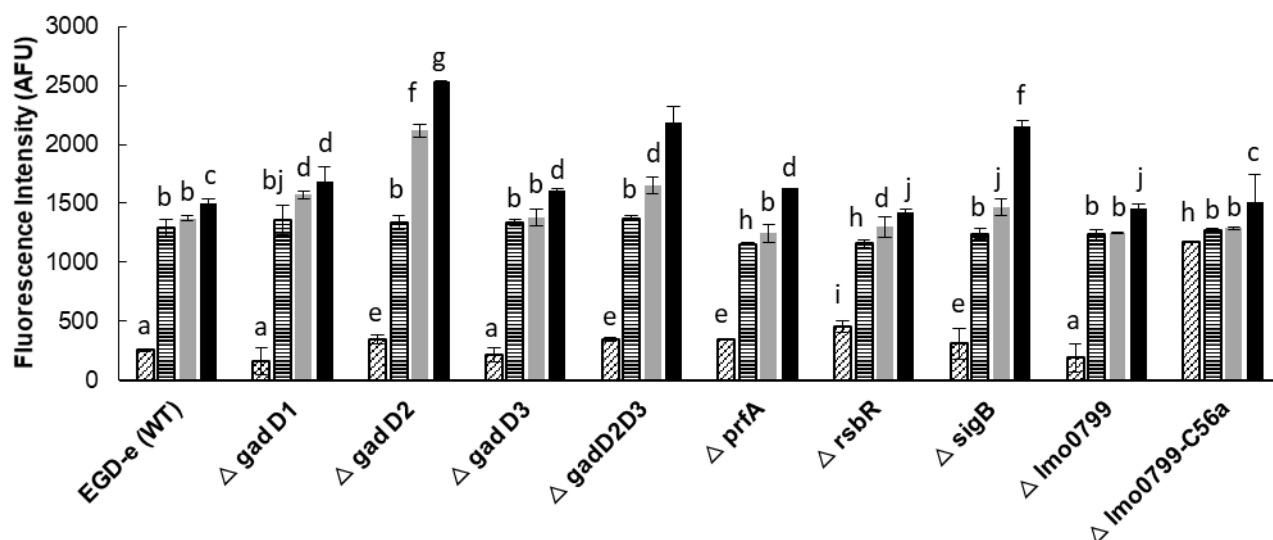

**Figure 5.1:** *L. monocytogenes* mutants and parent strain ROS density assay by DCFH.

▨ Control ▤ 1 min ACP treated ■ 3 min ACP treated ■ 5 min ACP treated

**Experimental conditions:** 1, 3, 5 min treatment at 80 kV, following 1 h post treatment storage. Untreated controls followed the same preparation procedure at all post-treatment storage times. Higher fluorescence signals detected in AFU indicates higher intracellular ROS concentration as measured by DCFH-DA. Column with different letters indicate a significant difference between bacterial strains and treatment time ( $p < 0.05$ ).

## 5.2 ACP Inactivation efficacy associated with treatment parameters

**Figure 5.2** shows the inactivation patterns for *L. monocytogenes* EGD-e and knockout mutants after ACP treatment and 1 h PTST. All mutants were similarly affected by direct exposure to plasma for 1 min ( $p > 0.05$ ), with different mutant responses noted only after 3 min plasma exposure.  $\Delta sigB$  and  $\Delta lmo0799-C56A$  were highly sensitive to ACP treatment, they exhibited lower survival levels than the parent strain and other mutant strains ( $p < 0.05$ ).  $\Delta lmo0799-C56A$  was reduced by 4.5 Log after 3 min exposure while  $\Delta sigB$  mutants were below the detection limit. Both EGD-e WT and other mutant strains showed 2.5-2.7 log

reduction after 3 min ACP treatment. No significant difference was recorded between the ACP inactivation rate of mutants ( $\Delta gadD1$ ,  $\Delta gadD2$ ,  $\Delta gadD3$ ,  $\Delta gadD2D3$ ,  $\Delta rsbR$  and  $\Delta lmo0799$  mutants) and parent strain. All strains tested were at the limit of detection ( $<1.0$   $\text{Log}_{10}$  CFU/ml) after 5 min of treatment.

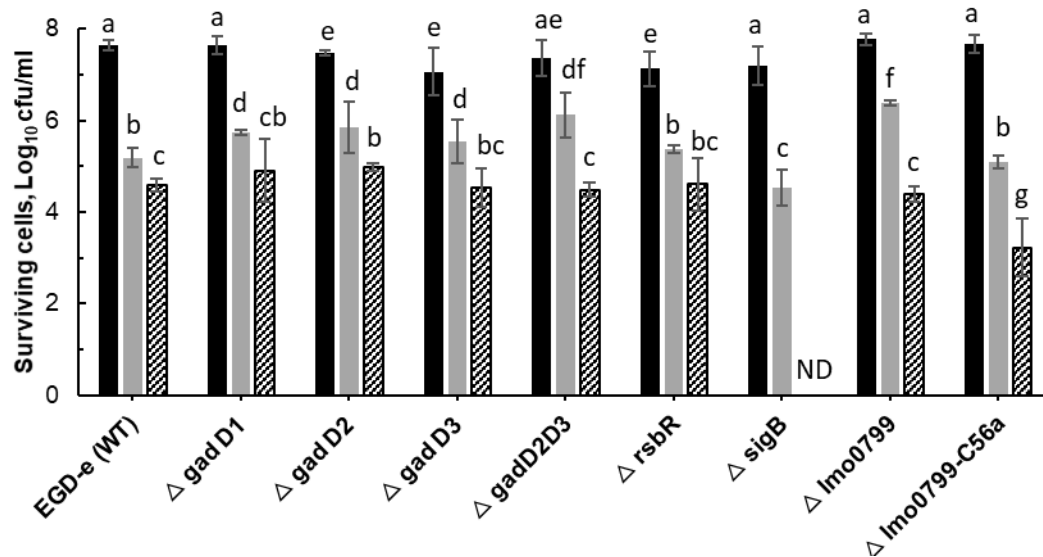

**Figure 5.2: Effect of ACP on *L. monocytogenes* EGD-e wild type and its knockout mutant strains.**

The graph displays surviving population of *L. monocytogenes* after ACP treatment at variable time range (■ untreated control, ■ 1 min, ▨ 3 min) and 1 h of post treatment storage time. ND: Non-detectable (below detection limit of  $1.0 \text{Log}_{10}$  CFU/ml). Vertical bars indicate standard deviation. Column with different letters indicate a significant difference between bacterial strains and treatment time ( $p < 0.05$ ).

### 5.3 Assessing stress responses to ACP using *L. monocytogenes* knockout mutants

In order to ascertain if sub-lethal stress exposure could influence *L. monocytogenes* behaviour, ACP resistance was evaluated for the cultures exposed to cold ( $4^\circ\text{C}$ ) or acid (pH 4) stress for 1 h. Experiments focused on investigating the influence of stress adaptation on *Listeria monocytogenes* ACP resistance. The survival of *L. monocytogenes* EGD-e wild-type

strain was compared to its knockout mutants following exposure to sub-lethal stress and ACP treatment (**Table 5.1 and 5.2**). Application of direct plasma was found to be effective for reduction of both *L. monocytogenes* EGD-e wild type and mutants. However, there were significant effects of bacterial pre-treatment and conditions observed.

Applying a mild cold stress (4 °C) to *L. monocytogenes* EGD-e (WT) and knockout mutants ( $\Delta sigB$ ,  $\Delta lmo0799$ ,  $\Delta lmo0799-C56A$  and  $\Delta rsbR$ ) enhanced effects of ACP treatment. Notably, there was no significant difference observed between WT and mutant bacterial inactivation efficacy when exposed to cold stress or ACP treatment, except for the  $\Delta rsbR$  mutant which was reduced below detection limit after 1 min of treatment. The limit of detection was 1.0 Log<sub>10</sub> CFU/ml.

**Table 5.1: Influence of cold stress (4 °C) on ACP inactivation efficacy for *L. monocytogenes* EGD-e (WT) and its mutant strains.**

Strain	Condition	Initial population (Log <sub>10</sub> CFU/ml)	Log reduction after 1 min of ACP
<i>L. monocytogenes</i>	Control	7.68 <sup>ab</sup> ± 0.15	2.45 <sup>a</sup> ± 0.16
<b>EGD-e (WT)</b>	1 h exposure to 4 °C	8.10 <sup>b</sup> ± 0.40	4.17 <sup>b</sup> ± 0.05
<i>ΔsigB</i>	Control	7.04 <sup>a</sup> ± 0.59	2.67 <sup>a</sup> ± 0.39
	1 h exposure to 4 °C	7.55 <sup>a</sup> ± 0.02	3.89 <sup>c</sup> ± 0.08
<i>ΔrsbR</i>	Control	7.15 <sup>c</sup> ± 0.40	1.74 <sup>d</sup> ± 0.45
	1 h exposure to 4 °C	7.17 <sup>ac</sup> ± 0.38	7.17 <sup>e</sup> ± 0.38
<i>Δlmo0799</i>	Control	7.73 <sup>a</sup> ± 0.15	1.39 <sup>d</sup> ± 0.05
	1 h exposure to 4 °C	8.11 <sup>b</sup> ± 0.35	4.25 <sup>b</sup> ± 0.06
<i>Δlmo0799</i> C56A	Control	7.70 <sup>a</sup> ± 0.15	2.57 <sup>a</sup> ± 0.05
	1 h exposure to 4 °C	7.68 <sup>a</sup> ± 0.35	4.55 <sup>c</sup> ± 0.03

**Experimental conditions: 1 min of direct plasma treatment at 80 kV following 1 h of Post treatment storage time. SD: Standard deviation. Limit of detection was 1.0 Log<sub>10</sub> CFU/ml. Different letters indicate a significant difference between stress and non-stressed; among different ACP treated stressed and non-stressed strains (p<0.05).**

Adaptation of *L. monocytogenes* to stress can protect the pathogen to a variety of normal lethal conditions found in the environment (Lou and Yousef, 1997). In this study, all mutants subjected to the acid pH 4.0 stress were highly susceptible to ACP treatment (Table 5.2). All *L. monocytogenes* strains exposed to acid stress were reduced below the detection limit immediately after 1 min of treatment.

**Table 5.2: Effect of pre-exposure to mild acid condition (pH 4) on ACP inactivation efficacy for *L. monocytogenes* EGD-e (WT) and mutant strains.**

Strain	Condition	Initial population (Log CFU/ml)	Log reduction after 1 min of ACP
<i>L. monocytogenes</i>	Control	7.68 <sup>a</sup> ± 0.15	2.45 <sup>a</sup> ± 0.16
EGD-E (WT)	1 h exposure to pH 4	6.97 <sup>b</sup> ± 0.41	6.97 <sup>b</sup> ± 0.12
$\Delta$ <i>gadD1</i>	Control	7.59 <sup>a</sup> ± 0.25	1.90 <sup>c</sup> ± 0.08
	1 h exposure to pH 4	7.42 <sup>ac</sup> ± 0.29	7.42 <sup>d</sup> ± 0.29
$\Delta$ <i>gadD2</i>	Control	6.89 <sup>b</sup> ± 0.17	1.62 <sup>ce</sup> ± 0.41
	1 h exposure to pH 4	7.33 <sup>c</sup> ± 0.09	7.33 <sup>d</sup> ± 0.09
$\Delta$ <i>gadD3</i>	Control	7.30 <sup>ac</sup> ± 0.34	1.52 <sup>e</sup> ± 0.07
	1 h exposure to pH 4	6.33 <sup>d</sup> ± 0.24	6.33 <sup>f</sup> ± 0.24
$\Delta$ <i>gadD2D3</i>	Control	7.11 <sup>c</sup> ± 0.38	1.24 <sup>e</sup> ± 0.10
	1 h exposure to pH 4	7.46 <sup>a</sup> ± 0.15	7.46 <sup>d</sup> ± 0.15
$\Delta$ <i>rsbR</i>	Control	7.15 <sup>ac</sup> ± 0.41	1.74 <sup>c</sup> ± 0.15
	1 h exposure to pH 4	5.25 <sup>e</sup> ± 0.15	5.25 <sup>g</sup> ± 0.15
$\Delta$ <i>sigB</i>	Control	7.04 <sup>ac</sup> ± 0.51	2.67 <sup>a</sup> ± 0.41
	1 h exposure to pH 4	5.44 <sup>e</sup> ± 0.12	5.44 <sup>g</sup> ± 0.12
$\Delta$ <i>lmo0799</i>	Control	7.73 <sup>a</sup> ± 0.16	1.39 <sup>e</sup> ± 0.05
	1 h exposure to pH 4	7.10 <sup>c</sup> ± 0.23	7.10 <sup>d</sup> ± 0.23
$\Delta$ <i>lmo0799-C56A</i>	Control	7.70 <sup>a</sup> ± 0.28	2.57 <sup>a</sup> ± 0.05
	1 h exposure to pH 4	7.71 <sup>a</sup> ± 0.45	7.71 <sup>d</sup> ± 0.45

**Experimental conditions: 1 min of direct plasma treatment at 80 kV following 1 h of Post treatment storage time. SD: Standard deviation. Limit of detection was 1.0 Log<sub>10</sub> CFU/ml. Different letters indicate a significant difference between stress and non-stressed; among different ACP treated stressed and non-stressed strains (p<0.05).**

#### **5.4 Effects of ACP on *L. monocytogenes* and *prfA* mutant biofilms**

Previous studies with *L. monocytogenes* reference strains 10403S and EGD revealed a significant requirement of *prfA* for biofilm formation (Lemon *et al.*, 2010; Travier *et al.*,

2013). Therefore, to investigate the role of PrfA in biofilm formation, the  $\Delta prfA$  mutant with in frame deletion of *prfA* gene was analysed for biofilm formation on 96 well microtiter plates using crystal violet and plate count assay (**Figure 5.3**). Both strains showed an ability to attach to polystyrene. The  $\Delta prfA$  mutant displayed similar levels of biofilm compared to the wild type with no significant difference observed in means ( $p > 0.05$ ). Deletion of *prfA* did not show any impact on growth and/or biofilm formation in the  $\Delta prfA$  mutant.

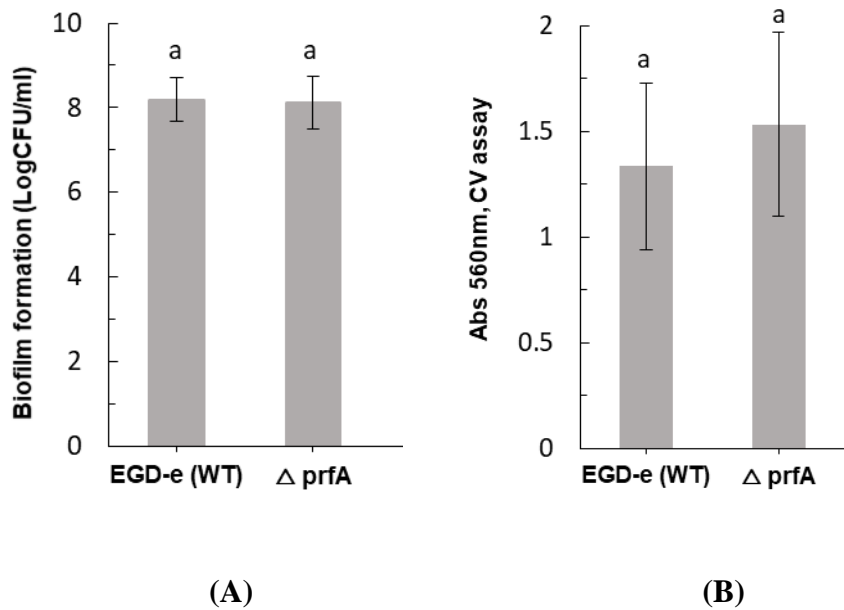
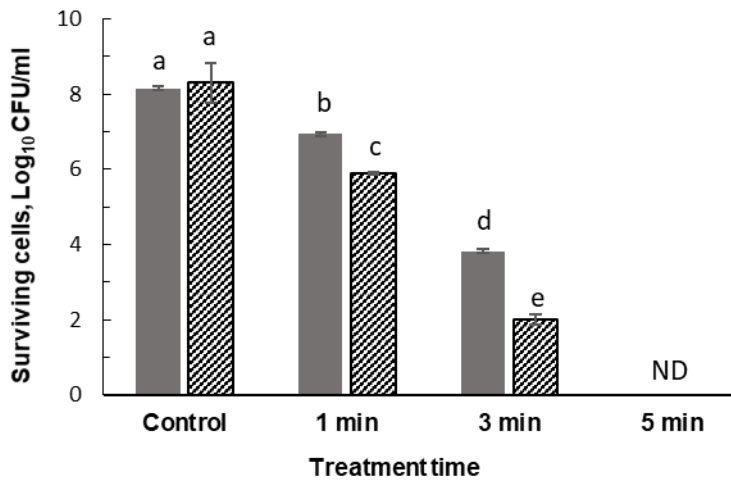

**Figure 5.3: Impact of *prfA* on biofilm formation. Biofilm formation by *L. monocytogenes* EGD-e (WT) and  $\Delta prfA$  mutant at 37 °C in TSB for 48 h, quantified by (A) plate count and (B) crystal violet assay.**

**Vertical bars indicate standard deviation. Column with different letters indicate a significant difference between EGD-e (WT) and *prfA* ( $p < 0.05$ ).**

Further, in order to study the effect of ACP treatment on *L. monocytogenes* biofilms, biofilms of the wild type and  $\Delta prfA$  mutant were treated with ACP for 1-5 min. **Figure 5.4** shows that the mutant was significantly more sensitive to ACP treatment. ACP treatment for 1 min with 1 h PTST led to a 1.2 log reduction of the wild type biofilm compared to 2.4 log reduction for the *prfA* mutant. However, metabolic activity of the wild type and *prfA* mutant were similarly

affected by plasma treatment for 1 min ( $p>0.05$ ), with difference in activity noted after 3 min plasma exposure.



(A)

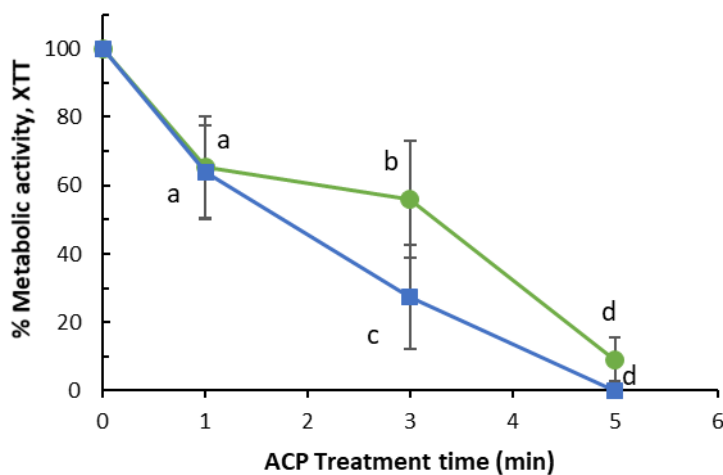

**Figure 5.4: Surviving population of 48 h *L. monocytogenes* after ACP treatment for 1, 3 and 5 min following 1 h PTST.**

**A) Plate count: (■) EGD-e WT, (▨)  $\Delta prfA$ . ND: non-detectable (Limit of detection 1 Log<sub>10</sub> CFU/ml).**

**B) XTT assay: (●) EGD-e WT assessed by XTT assay, (■)  $\Delta prfA$  assessed by XTT assay**  
**Vertical bars represent standard deviation. Column with different letters indicate a significant difference between bacterial strains and treatment time ( $p<0.05$ ).**



## 5.5 Effect of ACP on gene expression of stress induced genes

ACP has demonstrated an inhibitory effect on survival and longer plasma exposure appears to have the capacity to kill *L. monocytogenes* (Sections 5.2). Due to the inhibitory effects induced by extended in-package ACP exposure (5 min) to *L. monocytogenes* cells, the study further focused on the biological effects induced by short term (1 and 3 min) in-package ACP exposures to allow detection of early effects in terms of ACP modulated gene activities. The qRT-PCR assay was optimised by determining primer annealing efficiency for each primer pair. The melting curve analysis for selected primer pairs showed single peaks confirming that there was no DNA contamination. The PCR efficiency for the primers ranged between 94 to 96%. To determine the specific contributions of the transcriptional regulator  $\sigma^B$  to expression of *L. monocytogenes* virulence and stress response genes, transcript levels of selected  $\sigma^B$ -dependent genes were measured under sub-lethal stress conditions.

Expression of target genes (*gadD1*, *gadD2*, *gadD3*, *sigB*, *prfA*, *rsbR* and *lmo0799*) relative to the expression of the 16S rRNA gene after 1 and 3 min exposure to ACP is presented in **Figure 5.5**. The result showed that exposure to sub-lethal 1 min ACP increased gene expression of stress associated genes. *SigB* showed highest gene expression, increasing by  $15.60 \pm 3.9$  fold, followed by *gadD2* ( $7.19 \pm 0.5$ ) and *lmo0799* ( $8.6 \pm 2.08$ ) after 1 min exposure, compared to untreated controls. As expected when subjected to a harsh environment, *L. monocytogenes* increases expression levels of several stress related genes. However, longer ACP exposure decreased or in some cases downregulated the gene expression. *prfA* was down-regulated  $1.7 \pm 0.6$  fold after 3 min ACP while no significant induction or repression was noted for *gadD3*. The change in gene expression post treatment was mainly associated to ACP activity of bacteria.

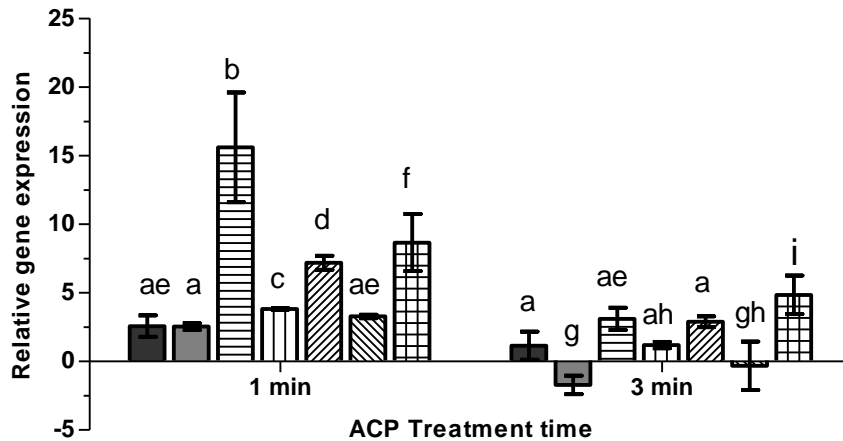

**Figure 5.5: Effect of ACP on gene expression of stress related genes in *L. monocytogenes* EGD-e (WT).**

■ *rsbR* ■ *prfA* ▨ *sigB* ▩ *gadD1* ▪ *gadD2* ▫ *gadD3* ▬ *lmo0799*. The y-axis represents the Log<sub>2</sub> fold change between untreated cells and ACP treatment cells (for 1 min or 5 min), determined by the delta-delta C<sub>T</sub> method. Vertical bars represent standard deviation in the mean of 2 independent repeats. Column with different letters indicate a significant difference between bacterial strains and treatment time (p<0.05).

## 5.6 Discussion

*L. monocytogenes* EGD-e is a persistent strain prevalent in food-borne illnesses, which is capable of surviving varied environmental and process conditions (NicAogáin and O’Byrne, 2016). Environmental stress such as acid, oxidative, cold or heat shock induced mutations can increase tolerance or resistance in bacteria (Delaquis and Bach, 2012). Bacterial adaptive strategies to stress cause changes in the gene expression pattern to maintain viability under harsh conditions. In order to design efficient ACP treatments, it is essential to understand the behaviour of the microorganism when exposed to different environmental and process stress conditions. Stress responses in *L. monocytogenes* have been extensively reported but investigations pertaining to cellular responses to cold plasma is still limited. ACP is

increasingly explored as a tool for decontamination in a wide range of sectors (Patange *et al.*, 2018; Sarangapani *et al.*, 2018). In the present work, the efficiency of the ACP for inactivation of *L. monocytogenes* with the effects of commonly encountered process conditions as extrinsic conditions with mechanistic insights were examined using a series of mutants with deletions relevant to ACP and other environmental stresses.

Atmospheric cold plasma is an excellent source of reactive species which contribute to bacterial inactivation process (Arjunan *et al.*, 2012; Wu *et al.*, 2012). The DCFH-DA assay demonstrated the generation of ROS in *L. monocytogenes* wild and mutant strains following treatment. The ROS generation increased with respect to ACP treatment time (Figure 5.1). The high ROS levels generated could induce oxidative stress which may cause deleterious effects in *L. monocytogenes* strains (Imlay, 2013) as observed in Figure 5.2. Previous studies have suggested the link between bacteria inactivation by ACP and ROS production (Han *et al.*, 2016). ROS, such as peroxide and superoxide generated inside a cell, cause a series of oxidation-reduction reactions mediated by iron-sulfur clusters, flavoproteins, and the Fenton reaction, generating further short-lived but high amounts of hydroxyl radical species which subsequently cause intracellular damage (Kohanski *et al.*, 2007). Han *et al.* (2016b) demonstrated ACP treatment increased overall amount of reactive species in *Escherichia coli* BW 25113 and its isogenic knockout mutants (*rpoS*, *soxR*, *soxS*, *oxyR* and *dnaK* genes) that led to the increased cell membrane permeability and sensitivity with 1 h and 24 h post treatment storage time.

The general mechanism by which plasma treatment can induce cell damage and cause cell death has been reported but there is scant information about the effects of ACP on stress regulated genes and the protection or sensitivity of microbial mutants with gene deletions against plasma treatment (Van Impe *et al.*, 2018). The survival of *L. monocytogenes* EGD-e wild-type strain was compared with that of its isogenic mutants following exposure to plasma

treatment. The same intensity plasma treatment had different effects on mutants with deleted genes associated with stress responses. The *SigB* mutant was more sensitive to ACP treatment than the wild type and other mutants which could be attributed to higher level of ROS detected in the cells. *SigB* is known as a crucial stress regulator and is responsible for regulation of several stress associated genes. *SigB* and *sigB*-dependent genes play an important role against oxidative stress, cold, and high hydrostatic pressure etc. (Chaturongakul *et al.*, 2008). *SigB* has demonstrated a protective role to oxidative stress (Ferreira *et al.*, 2001). Therefore, in the absence of *sigB*, the bacterial strain was sensitive and readily inactivated by plasma treatment. To investigate the role of *SigB* in *L. monocytogenes* stress adaptation, all the strain's survival patterns were compared under these lethal treatment conditions following a 1 h pre-exposure to sub-lethal levels of the acid/cold stresses (4 °C and pH 4.0). Pre-adaptation to acid or cold stress did not enhance the survival of any strain following exposure to plasma treatment. The wild type (WT) and mutants exhibited similar inactivation patterns. Despite the well-established role for *SigB*, there are several discrepancies reported by other researchers regarding its role under oxidative stress in *L. monocytogenes*. Studies by Boura *et al.* (2016) have shown that cells without *SigB* were more resistant to H<sub>2</sub>O<sub>2</sub> by at least 7 logs compared to its isogenic WT. The stationary phase cells grown aerobically were more resistant against H<sub>2</sub>O<sub>2</sub> at 30 °C than 37 °C. In contrast, survival experiments by Chaturongakul and Boor (2004) showed considerably reduced survival of the  $\Delta sigB$  strain relative to the parent strain and indicated a role for  $\sigma^B$  in oxidative-stress resistance in *L. monocytogenes* 10403S during exposure to cumene hydroperoxide (CHP). Interestingly in our study, hypersensitivity was observed in cells pre-adapted to cold or low pH conditions.

*L. monocytogenes* utilises the glutamate decarboxylase (GAD) system to survive under acid stress. Previous genetic studies on GAD system in *L. monocytogenes* EGD-e have shown

that *gadD1*, *gadD2* and *gadD3* are critical for survival of *L. monocytogenes* at low pH (Wemekamp-Kamphuis *et al.*, 2004). Deletion of *gadD3* together with either *gadD1* or *gadD2* reduced acid tolerance in *L. monocytogenes* EGD-m, whereas resistant single mutants (*gadD1* and *gadD2*) showed greater acid survival than the parent strain (Feehily *et al.*, 2014). However, deletion of *gad* genes (*gadD1*, *gadD2* and *gadD3*) seemed to confer no protection against mild acid or ACP derived oxidative stress. Similarly, loss of sigma B-activating protein *rsbR* did not show any significant difference in its ability to survive at low pH as well as under oxidative stress (Table 5.2). Pre-adaptation to sub-lethal pH (4.0) and cold (4 °C) did not enhance the survival of either strain following exposure to ACP treatment. All pre-adapted *L. monocytogenes* strains were highly susceptible and were reduced below the detection limit within 1 min of the ACP treatment. The stress conditions used in this study may have been sufficiently lethal to have overwhelmed the possible *sigB* contributions to cellular survival.

RT-PCR was applied for gene expression studies, focused on expression changes of stress associated genes of *L. monocytogenes* (wild-type bacteria) after sub-lethal exposure to ACP. The expression of genes *sigB*, *prfA*, *rsbR*, *lmo0799*, *gadD* genes was quantified after 1 min and 3 min ACP treatment relative to untreated controls using 16s rRNA as the reference gene. An increase in gene expression was seen by all stress associated genes analysed after 1 min of ACP treatment. Longer treatment times reduced the gene expression and, in some cases, down-regulated *prfA* and *gadD3* gene expression. The RT-PCR results show a significant association between ACP exposure and *sigB* expression, confirming its essential function for the increased tolerance to stress factors. A significant correlation was observed for the expression of *sigB* associated genes and *sigB* after ACP treatment in *L. monocytogenes*. The *sigB* overexpression mainly occurred at sub-lethal ACP exposure (1 min) with higher gene expression of the *rsbR* and *lmo0799*; which could explain the significantly increased

expression of *sigB* gene. *RsbR* and *lmo0799* are integral parts of the stressosome complex, its contribution for  $\sigma^B$  activation cascade and  $\sigma^B$  activity (O'Donoghue *et al.*, 2016; van der Steen *et al.*, 2012) consequently leads to the transcription of the general stress response (GSR) regulon (NicAogáin and O'Byrne, 2016). *L. monocytogenes* EGD-e exposed to ACP for 3 min, the transcriptomic analysis revealed reduced expression of *sigB* and other stress associated genes. Hence, *L. monocytogenes* show changes in its resistance to different doses of plasma treatment due to the gene sensitivity to the plasma-driven alterations.

The intensity of ACP-induced oxidative stress generates high concentrations of intracellular ROS/RNS species. These reactive species react with nearby organics leading to chain oxidation and destruction of DNA molecules as well as cellular membranes and other cell components (Dobrynin *et al.*, 2009b). The deoxyribose sugar and the nucleobases of DNA are readily susceptible to direct oxidative/nitrosative attacks by ROS/RNS (Arjunan *et al.*, 2015). Following exposure to ACP, the SOS response regulon (consisting of several genes responsible for DNA repair mechanism, cell division) are significantly up-regulated (Sharma *et al.*, 2009). Previous studies by Xu *et al.* (2015), demonstrated an increase in the *Nfo* gene (encodes for endonuclease IV, a DNA repair protein), indicating that the bacterial DNA structures are gradually damaged with an increase in plasma exposure. The DNA repair protection largely depends upon the type, quantity and the exposure time of bacterial cell to generated ROS. In addition to oxidation of the deoxyribose sugar, ROS/RNS directly affects DNA damage repair enzymes and polymerases (Arjunan *et al.*, 2015) thus slowing the repair processes or preventing replication altogether. Similarly, Sharma *et al.* (2009) suggests that although plasma treatment led to the induction of *uvrA* and *uvrB* (that detect damaged nucleotides), the absence of *uvrC*, *uvrD* and *polA* leads to incomplete induction of the DNA damage repair mechanisms, thus causing cellular damage.

The  $\sigma^B$  regulon is the largest stress response regulon in *L. monocytogenes* and overlaps with several other regulatory systems. It has also been shown that environmental stress conditions can prime  $\sigma^B$ -regulated virulence functions of *L. monocytogenes* i.e.  $\sigma^B$  also contributes to transcription of the gene encoding the global *L. monocytogenes* virulence gene regulator, Positive regulatory factor A (*PrfA*) (O'Byrne and Karatzas, 2008; Scorti *et al.*, 2007); binds to the specific DNA sequence known as *prfA* box and positively regulates the expression of *L. monocytogenes* virulent genes including itself. Studies by Lemon *et al.*, (2010) and Luo *et al.* (2013) highlighted the importance of the *prfA* gene leading on extracellular biofilm formation and virulence; with the elimination of *prfA* gene led to reduced biofilm formation and contributed to altered gene expression patterns in several different strains of *L. monocytogenes*. In this study, both *L. monocytogenes* EGD-e (WT) and  $\Delta prfA$  strains showed similar biofilm formation in TSB at 37°C. This could be due to the flagellum-mediated motility in *L. monocytogenes* causing initial surface attachment and subsequent biofilm development. Lemon *et al.* (2010) also reported that *prfA* mutant's defect in biofilm development is observed after initial surface attachment and is significantly affected at biofilm maturation, virulence and resistance steps. Therefore, when biofilms of *L. monocytogenes* EGD-e (WT) and  $\Delta prfA$  were treated with ACP,  $\Delta prfA$  was found to be significantly more sensitive than the wild type strain with  $6.3 \pm 0.02$  Log<sub>10</sub> CFU/ml reduction of culturable cells and 72% reduction in metabolically active cells after 3 min of treatment. Further, the gene expression studies revealed the sub-lethal treatment of 1 min induced *prfA* gene expression; however, prolonged treatment of 3 min repressed the *prfA* expression by  $1.7 \pm 0.6$  fold. Expression of *prfA* gene is highly regulated by multiple promoters; it can be transcribed as bicistron, together with the upstream *plcA* gene and monocistronically from two promoters (*P1prfA* and *P2prfA*) directly upstream from the *prfA*, one of which is under control of *sigB* (Scorti *et al.* 2007). The partially  $\sigma^B$ -dependent *P2prfA* promoter contributes

to the majority of *prfA* transcript levels in both intra- and extracellular bacteria (Chaturongakul *et al.*, 2008). Therefore, when bacteria were exposed to ACP exposure, *sigB* is highly expressed which may contribute to increased gene expression of *prfA* (Rauch *et al.*, 2005). Similarly, Xu *et al.* (2015) demonstrated, plasma treatment induced transcription of genes associated with several important bio-molecular processes related to environmental stress resistance. Exposure of *S. aureus* cells to plasma treatment, up-induced gene (*IcaA*, *SarA*, *sigB*, *Rbf*, *LuxS*) responsible for polysaccharide intercellular adhesion, regulation and biofilm formation in *Staphylococcal* biofilms and significant difference in gene sensitivity was observed with plasma exposure for 10 and 30 min. Xu and colleagues employed a different plasma device, however, the key effectors are likely to be similar. Consequently, bacteria such as *L. monocytogenes* and *S. aureus* respond to sub-lethal plasma-derived stress conditions to regulate biofilm formation via bio-molecular processes on the genetic level. Hence, it is suggested that bacteria may show potential changes in its resistance to different doses of plasma treatment due to the gene sensitivity to the plasma-driven environmental alteration and the impact on the DNA repair mechanisms.

## 5.7 Conclusion

In summary, this study underlines and confirms that ACP treatment effectively reduced *L. monocytogenes* and its mutants with 3-5 min of treatment under stressed/non-stressed/biofilm conditions. In this work, the effect of different doses of ACP treatment was analysed for *L. monocytogenes* EGD-e at the gene transcription level. The results indicate that *sigB* is important for general stress resistance, with loss of the *sigB* gene significantly reducing bacterial resistance to ACP treatment. In addition, the *sigB* gene showed the highest gene expression under sub-lethal ACP treatment. The results show that plasma exposure can induce gene expression to different degrees. However, whether plasma exposure facilitates or attenuates resistance due to sub-lethal treatments requires further investigation. Hence, an



improved understanding of *L. monocytogenes* response to different stress factors is necessary, which may reveal a comprehensive mechanism of plasma induced effects as well as help evaluate the extent of changes in virulence or other biological properties as a response to stress and resistance-associated gene expression. This would contribute to an understanding of how to control and reduce these events. The experimental results presented here provide a baseline for understanding the bacterial genetic response to plasma stress and offers promising insights for optimising ACP applications.

## **Chapter 6 Efficacy of cold plasma functionalised water for improving microbiological safety of fresh produce and wash water recycling**

Fresh produce can be contaminated with a range of pathogenic bacteria and viruses, which can pose a serious health risk as this category of product are typically prepared, distributed, stored and consumed raw. Produce washing is widely used method to minimise the microbial risk and maintain the quality of raw fresh produce from the farm to the consumer along the food chain. The efficacy of plasma treatment to control microorganisms is dependent on many system and process related parameters including inducer gas, geometry of the system and the type of device used; thus, the key antimicrobial effectors and resulting efficacy may also differ (Han *et al.*, 2016a; Liao *et al.*, 2017). This study demonstrates the use of a submerged dielectric barrier discharge into water assisted by coaxial diffusers in addition to agitation of micro-bubbles to indirectly treat fresh produce with plasma functionalised water.

### **6.1 Inactivation of *P. fluorescens* on fresh lettuce by different plasma treatment methods**

Lettuce inoculated with *P. fluorescens* and refrigerated for 24 h to allow attachment was treated with plasma functionalised water in the treatment chamber. Efficacy in relation to agitation on or agitation off was compared. High speed agitation using a magnetic stirrer enhanced the ability of the plasma to inactivate bacteria on the lettuce surface (**Figure 6.1**). The purpose of washing fresh produce is to remove dirt and loosen microbial attachment to surfaces so they may be removed or subject to the action of any additive treatment within the water. High speed agitation may help distribute the plasma reactive species in the reaction mixture generated from plasma treatment, thus helping to remove and inactivate firmly attached microbial cells present at different niches on lettuce surfaces. Moreover, previous studies have demonstrated pre-treatment with sanitisers using micro-bubbles generation

improved the bactericidal effect for decontamination of fresh produce (Kim *et al.*, 1999; Soli *et al.*, 2010). Micro-bubbles have demonstrated high stability and surface area that can maintain ozone, which may improve antimicrobial efficacy. Marui (2013) demonstrated small micro-bubble increased the dissolved potential of ozone and free radicals by cracking of the bubbles. Diffusor assisted bubbling of plasma generated effluent in conjunction with high speed stirrer agitation was found to be efficient and was selected for further experiment conditions.

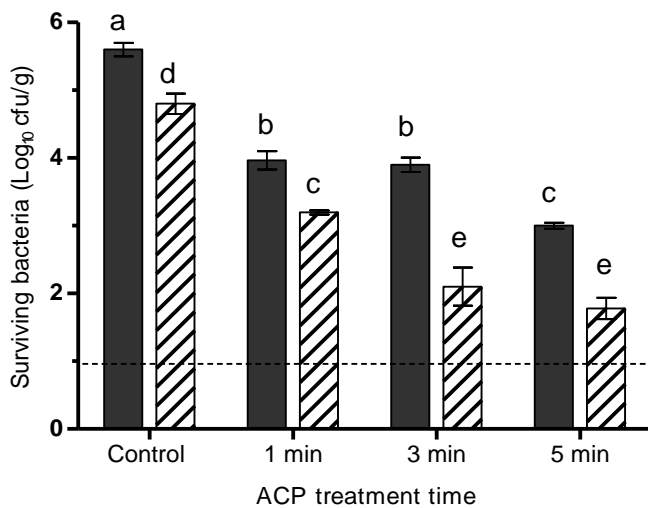

**Figure 6.1: Effect of ACP (▨) with or (■) without agitation on viable counts of *P. fluorescens* inoculated on lettuce.**

**Vertical bars indicate standard deviation. Dotted lines indicate limit of detection (1 Log<sub>10</sub> CFU/g). Column with different letters indicate a significant difference between treatment method and treatment time (p<0.05).**

## **6.2 Antimicrobial effect of micro-bubbling plasma functionalised water on lettuce**

The effect of ACP on the microbial load attached on iceberg lettuce, for 1 h and 24 h of bacterial attachment time was assessed. The initial levels of *L. innocua* and *P. fluorescens* on

lettuce was 6.2 and 6.8 Log<sub>10</sub> CFU/g. Washing the lettuce with sterile deionised water yielded 0.5 Log<sub>10</sub> CFU/g reduction after 10 min.

**Table 6.1: Washing lettuce with sterile deionised water with microbubbles and agitation in submerged DBD system without plasma treatment**

<b>Treatment time (min)</b>	<b><i>P. fluorescens</i> (Log<sub>10</sub> CFU/g)</b>	<b>SD</b>	<b><i>L. innocua</i> (Log<sub>10</sub> CFU/g)</b>	<b>SD</b>
<b>0</b>	6.04 <sup>a</sup>	0.10	6.14 <sup>a</sup>	0.15
<b>1</b>	5.72 <sup>b</sup>	0.14	5.66 <sup>b</sup>	0.06
<b>3</b>	5.63 <sup>b</sup>	0.11	5.65 <sup>b</sup>	0.28
<b>5</b>	5.60 <sup>b</sup>	0.04	5.40 <sup>b</sup>	0.16
<b>10</b>	5.18 <sup>c</sup>	0.10	5.42 <sup>b</sup>	0.13

**SD: Standard deviation. Different letters indicate significant difference between different treatment times of individual bacteria.**

Plasma bubbling into the produce treatment chamber increased the antimicrobial efficacy for lettuce samples significantly by comparison with bubbling of untreated water alone; **Figure 6.2.** Washing with untreated water had limited efficacy for microbial reduction regardless of the washing time. Values represent the average population recovered with a detection limit of 1 Log<sub>10</sub> CFU/g. The inactivation pattern for *P. fluorescens* population inoculated on lettuce followed a linear trend, showing significant reductions during 1-10 min of ACP treatment (p<0.05). In the case of *L. innocua* a significant reduction of 2-2.4 Log<sub>10</sub> CFU/g was observed after 3 min of ACP treatment; however, survival curves for *L. innocua* showed a tailing effect even after increasing the treatment time to 10 min.

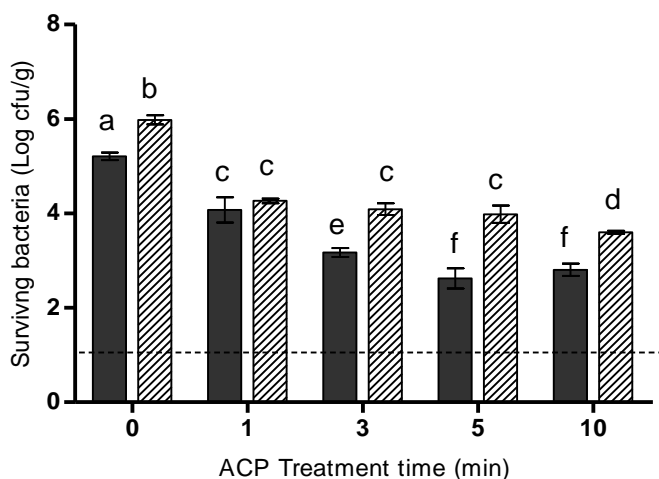

(A) *L. innocua*

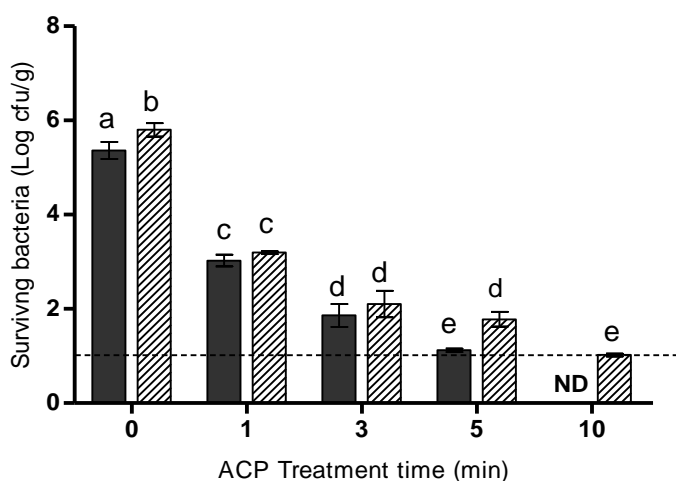

(B) *P. fluorescens*

**Figure 6.2: Effect of ACP on (a) *P. fluorescens* (b) *L. innocua* attached to lettuce leaves for (■) 1 h and (▨) 24 h. Each column represents average bacterial population recovered after ACP treatment.**

**Dotted line indicates limit of detection (1 Log<sub>10</sub> CFU/g). ND: Not detected (counts below detection limit). Vertical bars represent standard deviation. Column with different letters indicate a significant difference between bacterial attachment and treatment time (p<0.05).**

Gram negative bacteria have been shown to be more susceptible to ACP than Gram positive bacteria due to differences in cell wall structure (Mai-Prochnow *et al.*, 2016). The thick peptidoglycan layer of the Gram positive bacteria poses a barrier for plasma reactive species to penetrate through the cell wall and impacts its antimicrobial efficacy. This is in agreement with this study where despite similar initial inoculation levels on the lettuce surface, *P. fluorescens* decreased significantly in number after exposure to ACP treatment compared to *L. innocua*. In addition to target cell characteristics, the stage, strength and nature of bacterial attachment to produce may also impact overall ACP inactivation efficacy. Some foodborne pathogens attach and internalise into plant tissue thus contributing to elevated resistance to antimicrobial agents. Rough food surfaces or those characterised by stomata or seeds on surfaces present protective niches requiring longer treatment times. SEM micrographs of the lettuce surface show that treatment with plasma functionalised water for 1 and 3 min did not lead to any visible damaging effects (**Figure 6.3**), while significantly decreasing the bacterial population. Changes in the bacterial morphology was observed after 1 min of plasma treatment in the case of *P. fluorescens* and after 3 min of treatment the lettuce integrity was maintained whilst *P. fluorescens* populations remaining were at the detection limit.

(A) *Pseudomonas fluorescens*

(B) *Listeria innocua*

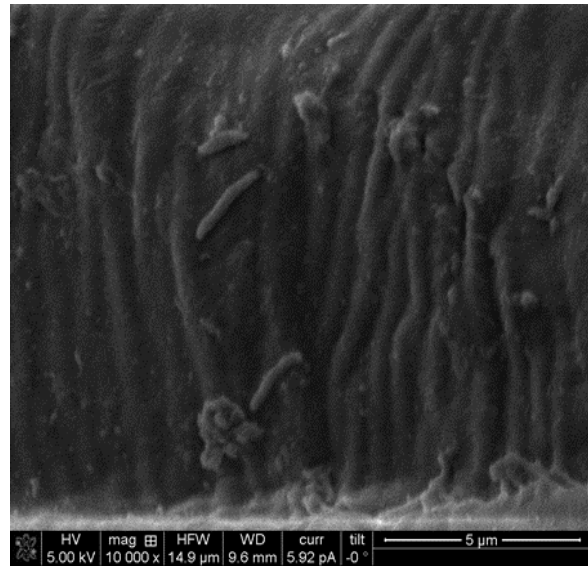
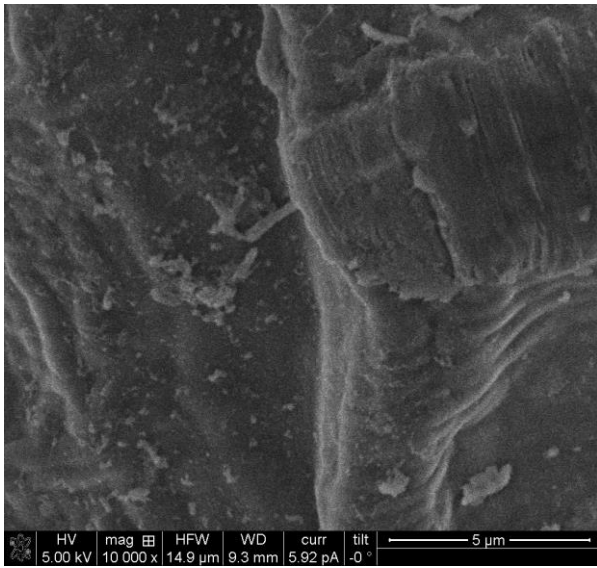

i. After water wash (Control)

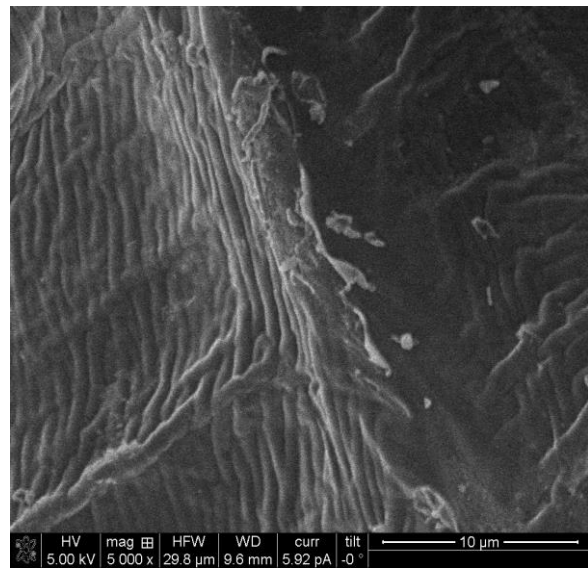
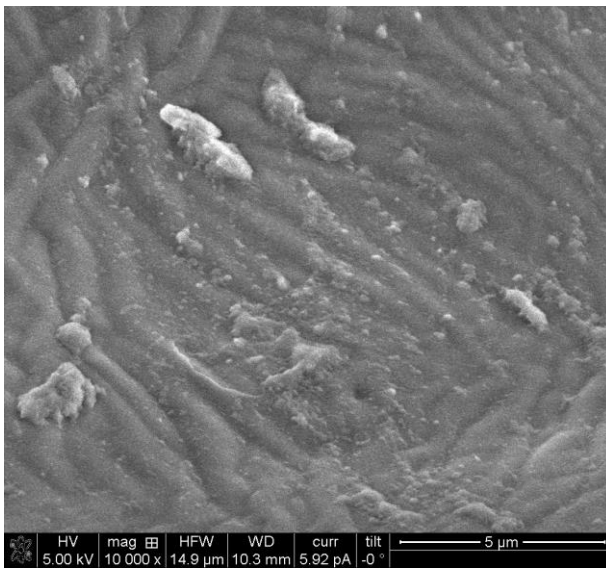

ii. 1 min ACP treatment

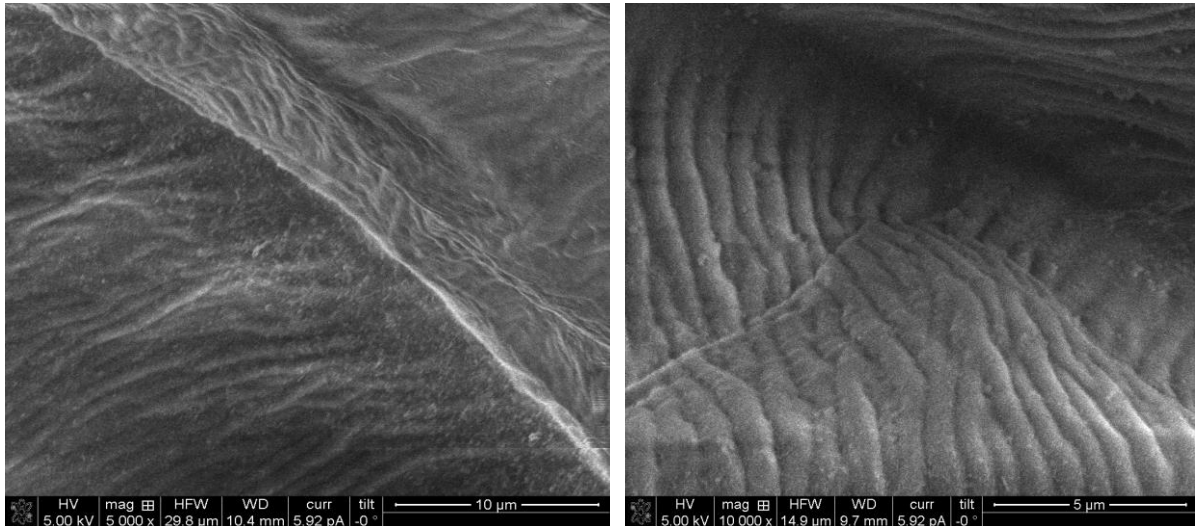

### iii. 3 min ACP treatment

**Figure 6.3: SEM images of *P. fluorescens* and *L. innocua* inoculated on lettuce. The photographs represent attachment of bacteria on lettuce and after ACP treatment.**



### 6.3 Wash water analysis

Contaminated produce wash water can be a vehicle for microbial cross-contamination through the transfer of microbial contaminants; usually requiring removal from the process or the addition of chemicals to decontaminate the water prior to re-use. Developing a chemical free intervention to enhance the safe recycle-ability of wash water is an important step for both water and energy sustainability as well as microbiological safety. The surviving bacterial load released from the lettuce to the process effluent is illustrated in **Figure 6.4**. Continuous bubbling and agitation of plasma effluent through the process water reduced the survival of microbes released into the process effluent. The microbial load in wash water declined continuously and was below the detection limit for *P. fluorescens* after 10 min contact time with plasma generated reactive species. Limitations associated with common chemical disinfectants include minimal efficacy, operational costs, the safety management of the technology at the processing site, formation of hazardous by-products and the need for monitoring ambient concentration levels (Van Haute *et al.*, 2015). In the case of ACP treatment, the continuous generation of plasma reactive species in the wash water provides a reservoir of active agents that can overcome scavenging by organic debris or contaminants and can also serve as a continuous treatment to either clean or refunctionalise wash water during and after the produce processing. This is advantageous from both cost and water sustainability perspectives.

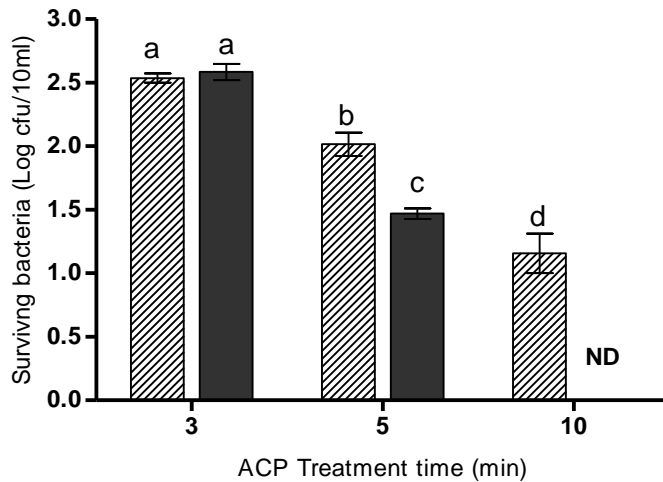
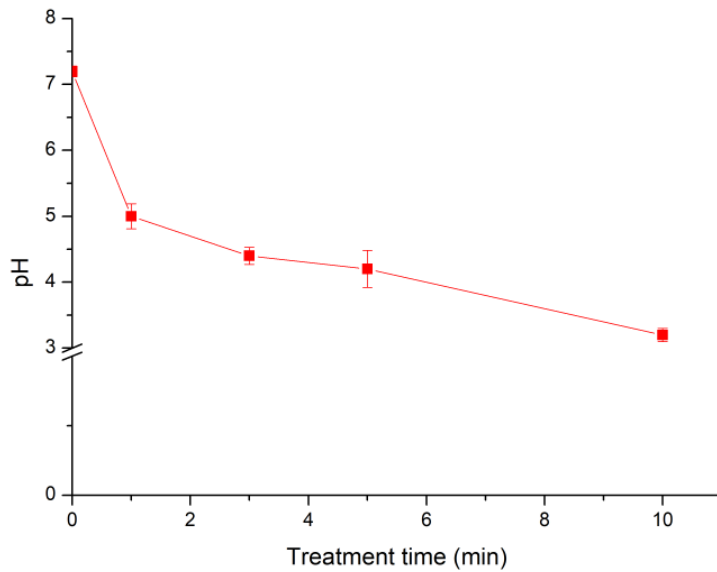

**Figure 6.4: Survival of (▨) *L. innocua* and (■) *P. fluorescens* in the wash water after washing lettuce in plasma functionalised water.**

**ND: not detected (below detection limit of 1 Log CFU/10ml); Vertical bars indicate standard deviation. Column with different letters indicate a significant difference between bacteria and treatment time ( $p < 0.05$ ).**

#### **6.4 Effect of pH**

**Figure 6.5** illustrates the changes in pH of the samples after plasma treatment. The initial pH of water used for treatment was  $7.2 \pm 0.1$ , which decreased with increasing plasma treatment time. The shift in pH can be attributed to production of acids including nitrates, nitrites and hydrogen peroxides (Oehmigen *et al.*, 2010). Similar results were obtained where plasma discharges lead to acidification of treated water (Lu *et al.*, 2017; Traylor *et al.*, 2011). Lower pH is favourable for reactive species to penetrate the cell wall, further affecting the bacterial membrane system (Bourke *et al.*, 2017; Ikawa *et al.*, 2010).



**Figure 6.5: pH value of wash water after DBD-ACP treatment**

To account for any independent effect of the acidic conditions, *L. innocua* was treated at different pH conditions. The bacterial inactivation was non-significant at the different pH conditions equivalent to those generated by 1, 3, 5 or 10 min of plasma treatment (**Figure 6.6**), with the exception of pH 5; where the bacterial population was reduced by  $1.3 \pm 0.13$  Log<sub>10</sub> CFU/g after 10 min treatment time. The same trend was recorded for *P. fluorescens* (data not shown). Satoh *et al.* (2007) reported that inactivation of *E. coli* in an acidified liquid (pH 3.4) needed a longer period of time compared to plasma treatment. However, others have demonstrated that an acidic environment along with addition of nitrate ions or hydrogen peroxide could not induce significant inactivation of microorganisms comparable to plasma treatment (Ercan *et al.*, 2013; Oehmigen *et al.*, 2010). The acidic environment alone did not have significant bacterial inactivation properties for the contact times used in this study, however the acid conditions generated may be complementary to the action of plasma functionalised water.

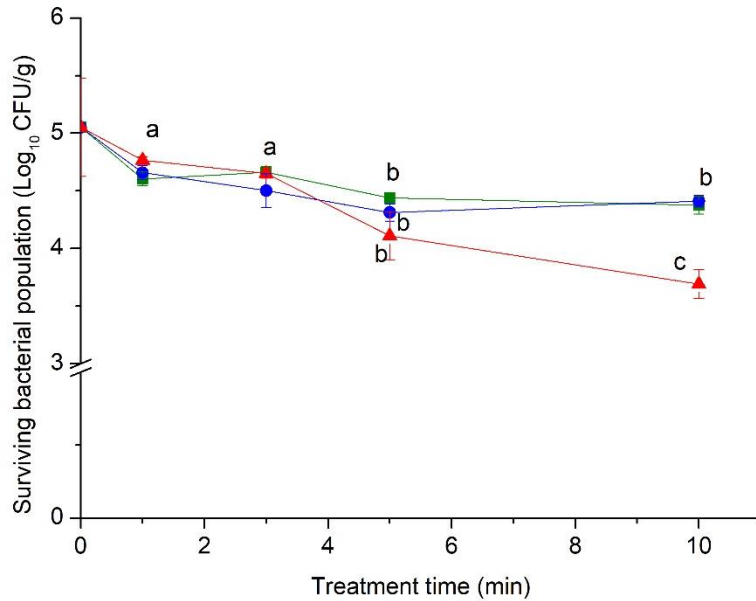

**Figure 6.6: Bacterial inactivation assay in acidic solutions. *L. innocua* ( $10^{7-8}$  CFU/ml) inoculated on lettuce exposed to different acidic conditions**

(■) pH 3, (●) pH 4 and (▲) pH 5. Detection limit was 1.0 Log<sub>10</sub> CFU/g. Vertical bars indicate standard deviation. Column with different letters indicate a significant difference between *L. innocua* treated in different pH solutions and treatment time ( $p < 0.05$ ).

## 6.5 Chemical analysis

### Measurement of hydrogen peroxide, nitrite, and nitrate concentrations

Plasma discharged in water produces reactive species such as superoxide, the hydroxyl radical, singlet oxygen, and nitric oxide (Schmidt-Bleker *et al.*, 2016). These short-lived species are converted rapidly to relatively longer lived species such as hydrogen peroxide, nitrites, nitrates and other uncertain intermediate species (Shimizu *et al.*, 2011). These diverse RONS play an important role in antimicrobial activity (Joshi *et al.*, 2011). The concentration of hydrogen peroxide ( $H_2O_2$ ), nitrate ( $NO_3^-$ ) and nitrite ( $NO_2^-$ ) reactive species generated after ACP treatment in water is presented in **Figure 6.7**. The plasma functionalised water generated using this submerged DBD diffuser contained higher concentrations of

nitrate but no detectable levels of hydrogen peroxide. The concentration of nitrate increased with respect to treatment time in the range of 250-400  $\mu\text{M}$ . However, a very low concentration of 12.63  $\mu\text{M}$  nitrite was detected only after 10 min of ACP treatment.

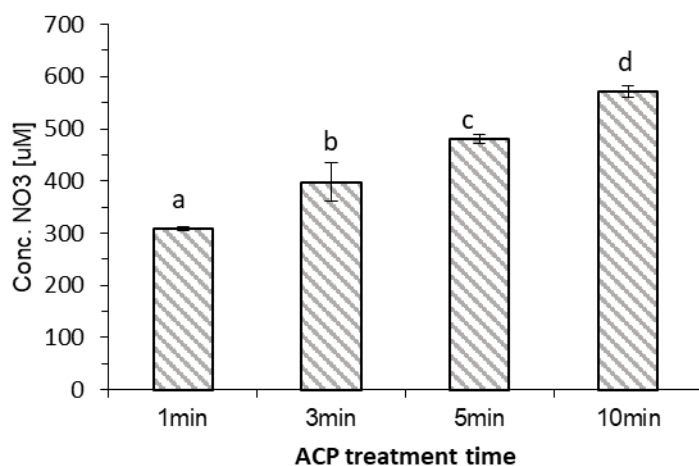

(a)

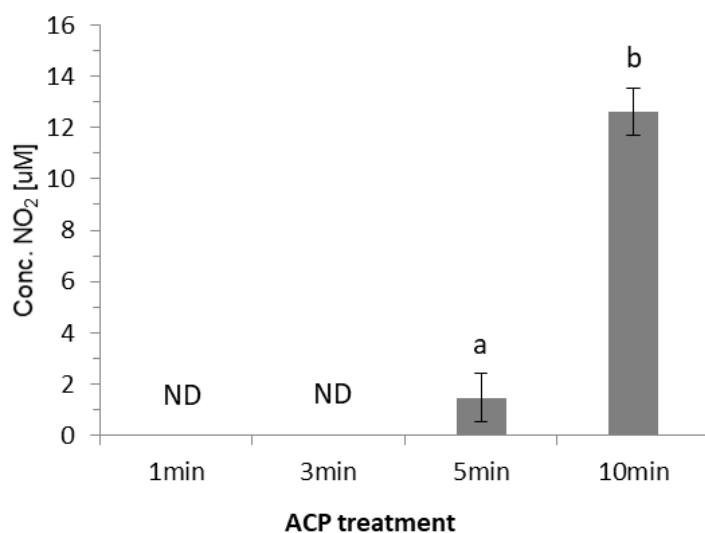

(b)

**Figure 6.7: Concentration of (a) Nitrate and (b) Nitrite reactive species in plasma functionalised water. Experimental conditions: 1, 3, 5 and 10 min treatment at 80 kV with 0 h post treatment storage time. ND: not detectable. Vertical bars indicate standard deviation. Column with different letters indicate a significant difference between different treatment times ( $p < 0.05$ ).**

The concentration of dissolved ozone concentration in the water was measured by the indigo degradation method. Ozone is another long lived ROS generated by atmospheric cold plasma discharge, and is a powerful oxidant, capable of inactivating various classes of pathogens. ACP treatment for 90 s increased the ozone concentration to 6 mg/L, but this remained constant after 120 s exposure time (**Figure 6.8**). The reactive species content in the plasma functionalised water indicated increased concentrations of nitrate and ozone with increasing plasma treatment times, with some nitrite detectable at 10 minutes. The type and concentration of RONS generated by plasma system depends on several factors including plasma-liquid interactions at the liquid surface (sputtering, high electric field induced hydrated ion emission, and evaporation), plasma source, discharge setup, gases and liquids used for treatment (Lukes *et al.*, 2014). Each plasma system offers differing reactive species composition, with diverse antimicrobial and cytotoxic activities, which points to the need for target or function led design of the appropriate plasma functionalised liquid.

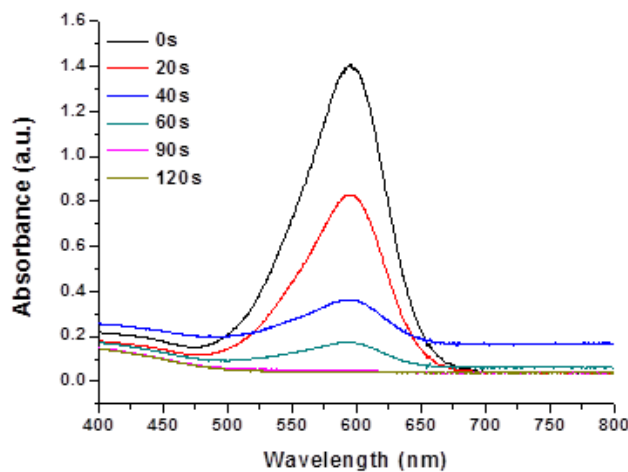

(a)

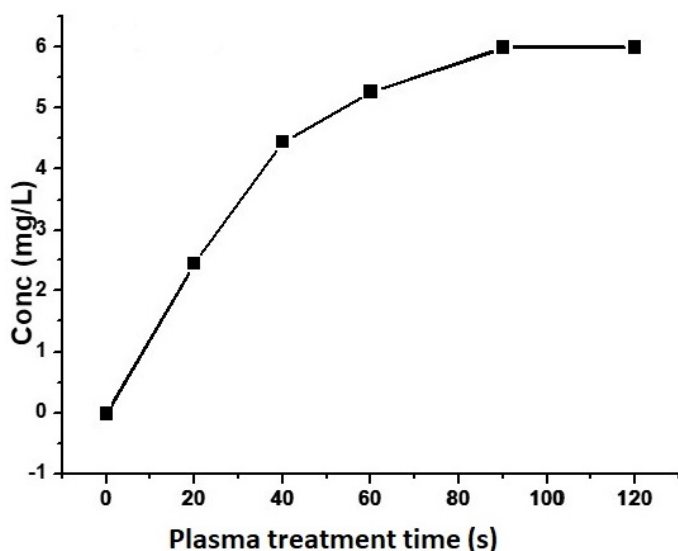

(b)

**Figure 6.8: (a) Absorption spectra of Indigo Reagent degradation by submerged DBD-ACP system and (b) Concentrations of dissolved ozone in water generated during plasma exposure time.**

### **6.6 Comparison of plasma functionalised water with sodium hypochlorite washing for bacterial reduction on lettuce**

Sodium hypochlorite solution and its derivatives are commonly used for sanitising fresh produce (Warriner *et al.*, 2009). The effectiveness of ACP was compared to commonly used NaOCl for decontamination of *L. innocua* and *P. fluorescens* attached on lettuce. The initial number of *L. innocua* and *P. fluorescens* attached to lettuce leaves was 5.2-5.6 Log<sub>10</sub> CFU/g and 5.0-5.4 Log<sub>10</sub> CFU/g, respectively. Both the treatments caused significant reduction in the bacterial counts when compared to corresponding controls. For *L. innocua*, both treatments (chlorine and ACP) showed similar reduction of 2.4-2.9 Log<sub>10</sub> CFU/g on lettuce after increasing the treatment time to 10 min ( $p > 0.05$ ). However, greater reduction in *P. fluorescens* population was observed with plasma water washing when compared to chlorine wash. With the same exposure duration, 100 mg/L chlorine wash achieved reduction of 4

Log<sub>10</sub> CFU/g while ACP treatment reduced the *P. fluorescens* population below detection limit **Figure 6.9.**

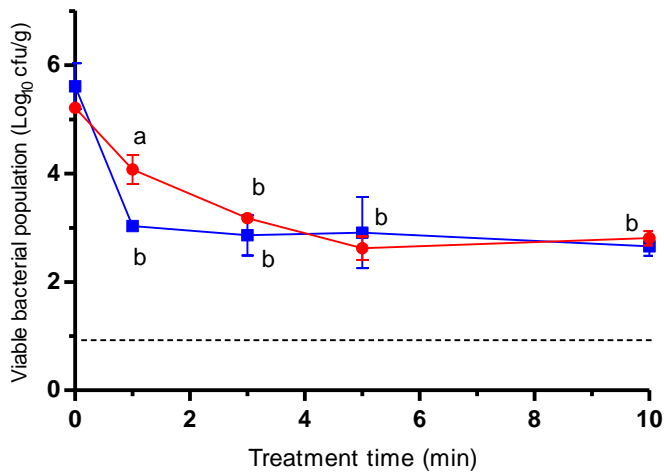

(A) *L. innocua*

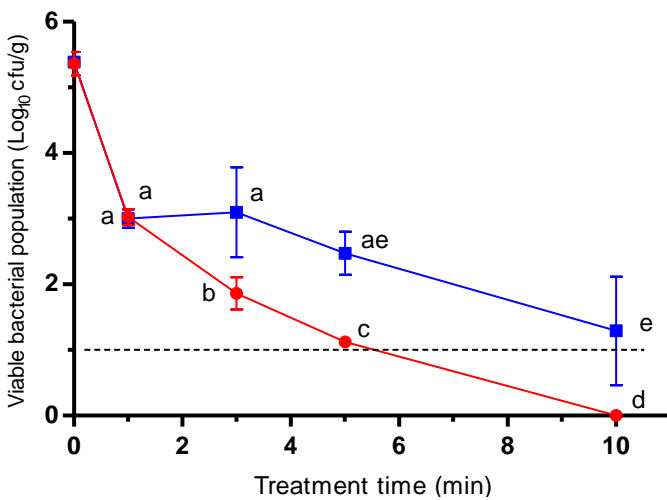

(B) *P. fluorescens*

**Figure 6.9: Effect of (■) NaOCl or (●) ACP on inactivation of *L. innocua* and *P. fluorescens* on lettuce. Dotted line indicates detection limit (1.0 Log CFU/g). Vertical bars indicate standard deviation. Column with different letters indicate a significant difference between Treatment type (NaOCl, ACP) and treatment time ( $p < 0.05$ ).**

The disinfection efficiency of chlorine washes varies; for example, sanitizing with 0.02% SH (200 mg/L free chlorine) reduced background microbiota on strawberry, cherry tomato, and



red bayberry by approximately 0.20–2.07 log cfu/g (Wei *et al.*, 2017). Other studies reported 0.76 log CFU/g, 0.79 log CFU/g, and 0.47 log CFU/g Log reductions of initial coliform from fresh-cut radishes, zucchini, and green bell peppers after washing with 100 mg/L sodium hypochlorite (Sun *et al.*, 2012). Although chlorine is commonly applied as a disinfectant in washing fresh produce, a challenge is to maintain a stable free chlorine concentration during washing, necessitating continuous monitoring and dosing. Plasma functionalised water achieved control comparable to chlorine treatment of *L. innocua*, but eradicated *P. fluorescens* populations below the detection limit, offering potential for delayed spoilage and shelf-life improvement. In addition, micro-bubbling of the plasma effluent and high speed agitation helped distribute RONS, providing greater microbial reactive species interactions.

## **6.7 Conclusion**

The efficacy of ACP to inactivate microbial loads depends on many factors for example the product type, target microorganism, pH of wash water and contact time of treatment. These findings demonstrate aqueous plasma treatment can effectively reduce viable counts of pathogenic and spoilage microorganisms attached on lettuce. ACP functionalised water was efficient to control *L. innocua* while reducing *P. fluorescens* population below detection limit from lettuce, as well as from the wash water used for the treatment. In addition, micro-bubble and high speed agitation aided distribution of the active agents and enhanced microbial: reactive species interactions.

The fresh produce industry currently lacks an efficient control method to ensure removal or elimination of food-borne microorganisms from fresh or minimally processed fruits and vegetables, which is compounded by increasing consumer concerns with standard chemicals including chlorine. Extending the safe shelf life of minimally processed fresh produce is of paramount importance to promote safe consumption and consumer confidence, pre-washing the fresh cut lettuce in plasma functionalised water could be an efficient replacement or

additional technology for commercial processing lines. Moreover, ACP shows potential for improving water recycling by minimising the contaminant load in wastewater, thereby, significantly lowering the consumption of free chlorine and organic chlorine residues in the wastewaters.

## Chapter 7 ACP treatment of wastewater effluents

Generation of wastewater is one of the main environmental sustainability issues across food sector industries. The constituents of food process effluents are often complex and require high energy and processing for regulatory compliance. Wastewater streams are the subject of microbiological and chemical criteria and can have a significant eco-toxicological impact on the aquatic life. Thus, innovative treatment approaches are required to mitigate environmental impact in an energy efficient manner. Here, DBD atmospheric cold plasma (ACP) was evaluated for control of key microbial indicators encountered in food industry effluent. A sequence of experiments was performed to determine the best treatment parameters for bacterial inactivation efficiency within complex effluents. This study also investigated the eco-toxicological impact of cold plasma treatment of the effluents using a range of aquatic bioassays.

### 7.1 Effect of retention time on bacterial inactivation

The preliminary post treatment retention treatment (PTRT) studies were performed in simple phosphate buffer solution in presence of *E. coli*. Post treatment retention was carried out by holding the opened wastewater sample post ACP treatment so as to imitate the treatment system tank conditions which is used to hold wastewater. **Figure 7.1** shows the inactivation of *E. coli* after ACP treatment at 80 kV for 30-60 s of plasma followed by variable PTRT of 0, 5 and 10 min. *E. coli* populations decreased with increasing retention time and no cells were detected after 10 min of Post treatment retention time (PTRT). When the plasma treatment time was reduced to 30 seconds, the same trend was repeated where microbial loads went from 5 Log<sub>10</sub> to 1 Log<sub>10</sub> CFU/ml after 10 min of retention time. Thus, retention time emerged as a critical processing parameter for microbial control and a retention time of 10 minutes after a 1-minute treatment at 80 kV of voltage was sufficient for effective bacterial inactivation. These results indicate the high efficiency of ACP at short treatment and

retention times which can assist in fast processing rates of wastewater decontamination industrially.

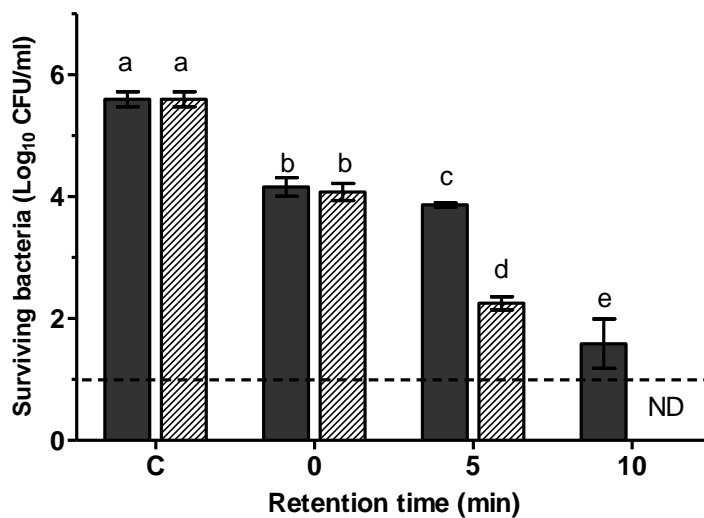

**Figure 7.1: Effect of post treatment retention time (0, 5, 10 min) on stationary phase *E. coli* treated with DBD ACP system for (■) 30 s and (▨) 60 s and at 80 kV in phosphate buffer solution.**

**ND: Non-detectable, Dotted line indicates limit of detection (1 Log<sub>10</sub> CFU/ml); C: Control. Vertical bars represent standard deviation. Column with different letters indicate a significant difference between controls and ACP treated samples at different time points (p<0.05).**

## **7.2 Effect of voltage level and treatment time on bacterial inactivation efficiency by ACP**

The relationship between bacterial inactivation with the treatment voltage levels is represented in the **Table 7.1**. Experiments were conducted using voltage of 60–80 kV, treatment time of 1–5 min and PTRT of 10 min. Increasing voltage level gradually enhanced the rate of microbial inactivation in model dairy wastewater, which was most notable after 2 and 5 min of ACP treatment for all bacteria examined. Increased voltage level at 80 kV archived significantly greater reduction of  $\pm 2.0$  Log CFU ml<sup>-1</sup> in all bacterial population as compared to lower voltage level tested (p < 0.05).

**Table 7.1: Effect of Atmospheric cold plasma on bacteria inactivation at various applied voltage levels with 10 min Post treatment retention time.**

Voltage level (kV)	Treatment time (min)	<i>E. coli</i>		<i>E. faecalis</i>		<i>C. perfringens</i>	
		Log <sub>10</sub> CFU/ml	SD	Log <sub>10</sub> CFU/ml	SD	Log <sub>10</sub> CFU/ml	SD
<b>60</b>	0	5.68 <sup>a</sup>	0.23	5.60 <sup>a</sup>	0.16	5.65 <sup>a</sup>	0.22
	1	4.92 <sup>b</sup>	0.11	4.46 <sup>b</sup>	0.09	4.77 <sup>c</sup>	0.23
	2	4.79 <sup>b</sup>	0.07	4.14 <sup>d</sup>	0.08	4.42 <sup>d</sup>	0.15
	5	ND <sup>f</sup>	-	2.67 <sup>f</sup>	0.05	ND <sup>f</sup>	-
<b>70</b>	0	5.62 <sup>a</sup>	0.09	5.70 <sup>a</sup>	0.03	5.65 <sup>a</sup>	0.22
	1	4.61 <sup>c</sup>	0.02	4.87 <sup>c</sup>	0.12	4.70 <sup>c</sup>	0.09
	2	3.95 <sup>d</sup>	0.19	4.34 <sup>d</sup>	0.10	3.55 <sup>d</sup>	0.21
	5	ND <sup>f</sup>	-	ND <sup>e</sup>	-	ND <sup>f</sup>	-
<b>80</b>	0	5.68 <sup>a</sup>	0.23	5.90 <sup>a</sup>	0.08	5.32 <sup>b</sup>	0.11
	1	4.77 <sup>b</sup>	0.08	4.58 <sup>b</sup>	0.07	4.49 <sup>d</sup>	0.07
	2	2.87 <sup>e</sup>	0.18	3.42 <sup>e</sup>	0.30	3.78 <sup>e</sup>	0.13
	5	ND <sup>f</sup>	-	ND <sup>e</sup>	-	ND <sup>f</sup>	-

**SD: standard deviation, ND: non-detectable (below 1 Log<sub>10</sub> CFU/ml). Different letters indicate significant difference between voltage levels and treatment time of individual microbe.**

Bacterial inactivation at 80 kV in relation to ACP treatment time in model dairy and meat wastewater is further summarised in **Figure 7.2**. The initial bacterial concentration inoculated in model dairy wastewater before treatment was  $5.6 \pm 0.1$  Log<sub>10</sub> CFU/ml of *E. coli*,  $5.9 \pm 0.3$  Log<sub>10</sub> CFU/ml of *E. faecalis* and  $5.3 \pm 0.3$  Log<sub>10</sub> CFU/ml of *C. perfringens* respectively. Significant reduction of  $\pm 1$  Log<sub>10</sub> unit of bacterial concentration was observed after 1 min of the ACP treatment ( $p < 0.05$ ) in the dairy wastewater. However, bacterial indicators in meat wastewater were found to be much more sensitive to plasma treatment, with most bacterial populations being affected at 1 min of ACP treatment and showing complete inactivation

after 2 min of treatment. Therefore, increasing the ACP treatment time with a PTRT of 10 min significantly enhanced the rate of bacteria inactivation, with no culturable cells detected after 5 min treatment.

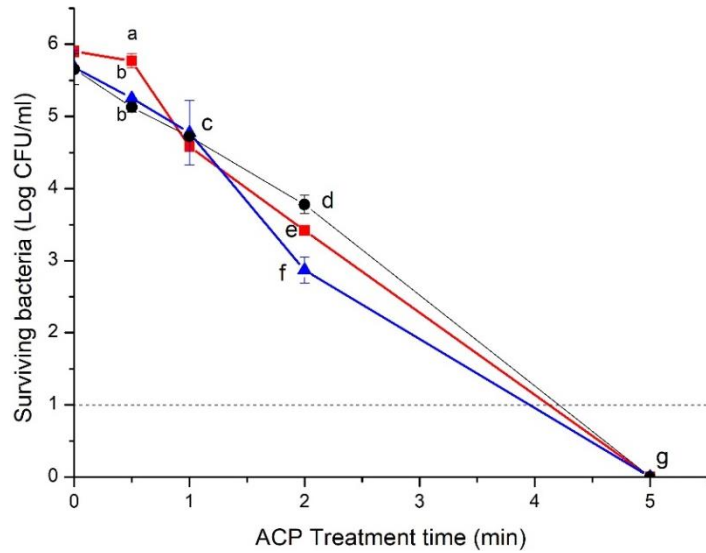

(A) Dairy wastewater

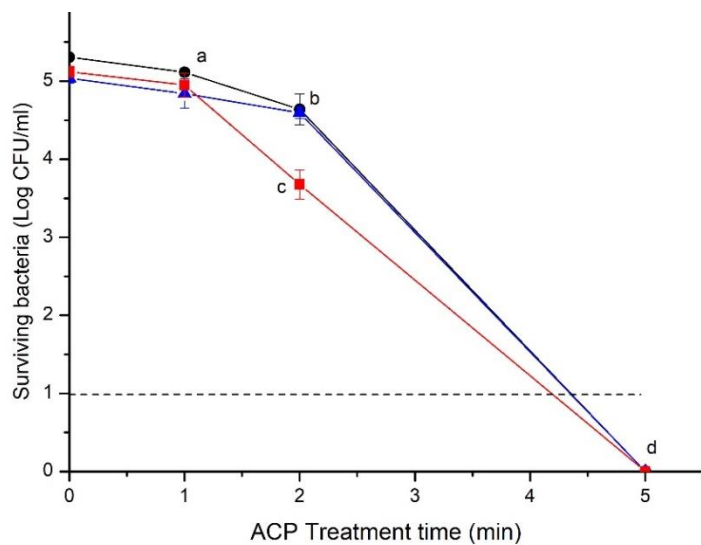

(B) Meat wastewater

**Figure 7.2: Effect of ACP treatment time on stationary phase (▲) *E. coli* (■) *E. faecalis* and (●) *C. perfringens* in model (A) dairy (B) meat wastewater treated at 80 kV with post treatment retention time of 10 min. Dotted line indicates limit of detection (1 Log<sub>10</sub> CFU/ml). Vertical bars represent standard deviation. Column with different letters**

**indicate a significant difference between three bacterial samples, their controls and ACP treated samples ( $p < 0.05$ ).**

ACP treatment generates several reactive species which are an excellent source of ROS and RNS. These reactive species are mediated in secondary stable forms in liquids and penetrate into bacterial cells and membranes causing damage to membranes or intracellular functions (Han *et al.*, 2016a). Erosion of cell components affects the cell membrane causing oxidation of free fatty acids, lipids and protein components. This etching activity leads to irreversible damage to DNA, RNA and enzymes eventually causing cell lysis or cell death (Daş *et al.*, 2006; Dobrynin *et al.*, 2009c). The highest applied voltage and the longest treatment time yielded the highest rate of inactivation. The high voltage levels in addition to longer treatment times in a contained environment may also contribute to increased concentration of active species amplifying the adverse effect on nucleic acids, affecting DNA with the loss of cell culturability. This is in agreement with earlier studies (Han *et al.*, 2014; Janex *et al.*, 2000; Liu *et al.*, 2013) which demonstrated the relationship between the reactive species and higher voltage and treatment time that influence the bacterial inactivation rate by reducing bacterial metabolism or by changing the permeability of the cell membrane.

### **7.3 Effect of the milk fat content on bacterial inactivation with ACP treatment**

The relative amounts of the fats and proteins in wastewaters from the dairy or meat industry can vary considerably and may not be of routine concentration or composition, even within a sector. A rich organic environment can impact on the antimicrobial efficacy of ACP (Han *et al.*, 2016b). The active species generated not only react with the target contaminant but also with degraded products of organic components within the wastewater. The bacterial inactivation efficiency of ACP was further challenged with two synthetic wastewater samples containing additional fat content, at 4 g/L and 2 g/L by comparison with the initial dairy wastewater composition (0.2 g/L milk fat) (**Figure 7.3**).

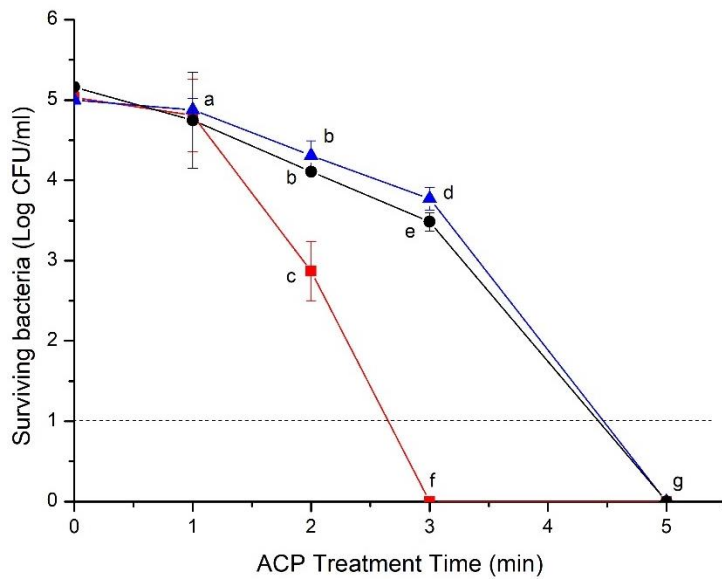

**Figure 7.3: Inactivation of *E. coli* in stationary phase suspended in model dairy wastewater at different fat content (■) 0.2 g/L (▲) 2 g/L and (●) 4 g/L.**

**Dotted line indicates limit of detection (1 Log<sub>10</sub> CFU/ml). Vertical bars represent standard deviation. Column with different letters indicate a significant difference between milk fat content and treatment time (p<0.05).**

The bacterial inactivation efficiency by ACP in fat rich wastewater was slower than in the lower fat content wastewater. The protective effect of organic matter upon the bacterial cells during ACP treatment and the variability in levels that may challenge a process must be considered. The organic matter present in the dairy wastewater can scavenge reactive species preventing their interaction with the bacterial cells present. The reactive species react and oxidise the organic content present in the dairy wastewater, in particular double bonds of unsaturated compounds to low molecular compounds (El-Sayed *et al.*, 2015) thus making them unavailable to interact with the bacteria. However, as the treatment time increased to 5 minutes the ACP can effectively inactivate the target microorganisms in dairy wastewater; the fat content induced shoulder on inactivation can be overcome by extending the treatment time. Similar results were obtained by Ziuzina *et al.* (2015) and Han *et al.* (2016b), distinct differences in bacterial inactivation efficiencies were observed across different ACP treated



media, with lower levels of ROS observed in beef extract and lettuce broth by comparison with PBS, although the same ACP treatment parameters were used for all the suspensions. The low ROS concentration detected may reflect a scavenging effect of the media, allowing bacterial cells to recover and grow.

Further chemical characterisation of plasma treated dairy and beef lipids performed by Sarangapani *et al.* (2017) gives insights on cold plasma-food interactions in terms of quality effects, particularly for oils and fats present in food industry wastewater. The plasma process was found to oxidise the fat content into simpler fatty acids study along with formation of oxidation products 2-nonenal, azelaic acid, 9-oxononanoic acid, nonanoic acid and octanoic acid. However, these oxidation products were identified only after extended treatment time of 30 min. Findings from the current study illustrate the efficacy of ACP depends on water matrix/organic content as well as treatment time. Food industrial wastewaters vary in nutrient/organic content and concentrations. The final inactivation efficacy may therefore be influenced by further factors such as product parameters including potential to scavenge reactive species as well as significant dependency on the ACP system prototype geometry and treatment conditions.

#### **7.4 Inactivation of mixed culture bacteria from the wastewater effluents**

In order, to evaluate the performance of ACP treatment for poly microbial challenges a bacterial cocktail was prepared in model wastewater effluents. A mixed culture prepared using *E. coli*, *E. faecalis* and *C. perfringens* was treated with ACP at 80 kV for different treatment time periods (**Figure 7.4**). Significant reduction ( $p < 0.05$ ) in the mixed culture was observed after 5 min of ACP treatment, showing rapid reduction of *E. coli* and *E. faecalis* to levels of 3.0 to 3.4 Log<sub>10</sub> CFU/ml. *C. perfringens* appeared to be significantly more resistant to ACP treatment ( $p \leq 0.05$ ), showing reduction of 1.7 Log<sub>10</sub> CFU/ml after 5 min of ACP treatment. Complete elimination of mixed culture bacteria required a doubling of treatment

time to 10 min. However, prolonging the treatment time to 10 min reduced all bacterial population below detection limits.

While in case of mixed culture bacteria suspended in model meat wastewater were significantly sensitive to ACP treatment as compared to mixed culture bacteria in model dairy wastewater ( $p < 0.05$ ). A marked decrease of 1-2  $\text{Log}_{10}$  CFU/ml was observed in *C. perfringens*, *E. faecalis* and *E. coli* cell population suspended in model meat wastewater after 2 min of treatment duration. For longer treatment time of 5 min, the total bacterial population concentrations were more rapidly inactivated to undetectable levels.

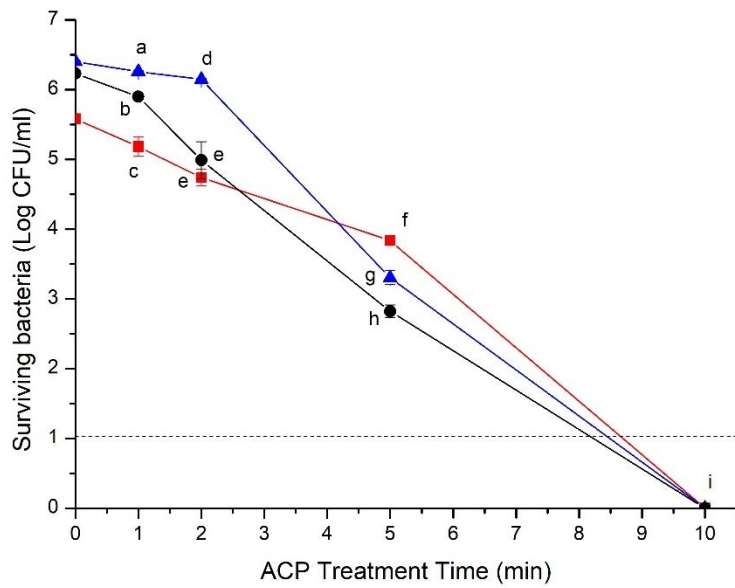

(A) Dairy wastewater

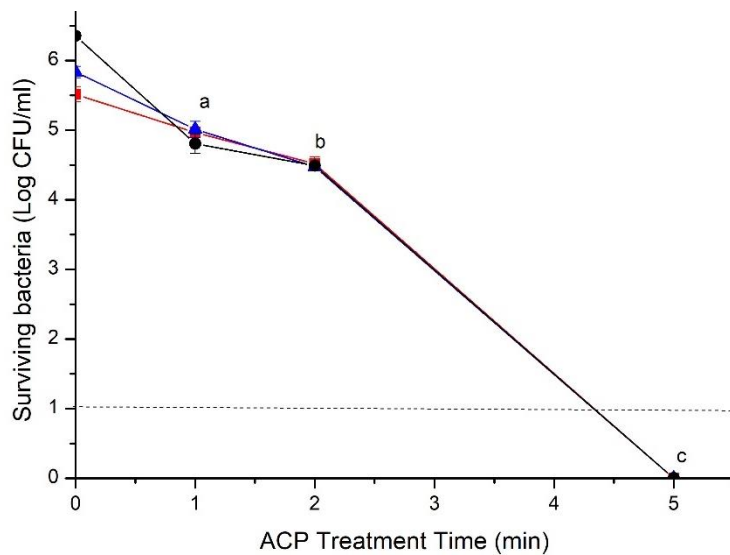

(B) Meat wastewater

**Figure 7.4: Inactivation of mixed culture bacterial strains of (■) *C. perfringens* (●) *E. coli* (▲) *E. faecalis* in stationary phase suspended in model dairy and meat wastewater treated with ACP treatment at 80 kV.**

**Dotted line indicates limit of detection (1 Log<sub>10</sub> CFU/ml). Vertical bars represent standard deviation. Column with different letters indicate a significant difference between bacterial culture and treatment time (p<0.05).**

The inactivation rate of the mixed culture cocktail was slower by comparison to the respective mono culture preparations, which may be due to the overall higher bacterial load and the greater potential for organic based quenching of the reactive species generated by ACP treatment which are ultimately responsible for bacterial cell death. Different membrane structures could lead to different relative resistance between the bacterial strains (Han *et al.*, 2015), however, further fundamental insights are required into how poly-microbial communities behave in response to the stresses imposed by ACP.

### **7.5 Generation of reactive species**

The atmospheric plasma discharge is an effective source of reactive oxygen and nitrogen species (RONS). Hydrogen peroxide ( $\text{H}_2\text{O}_2$ ), nitrates ( $\text{NO}_3^-$ ) and nitrites ( $\text{NO}_2^-$ ), are biologically active species known to induce cell proliferation and cause substantial degrees of damage to bacterial cells. In the current study, concentrations of  $\text{H}_2\text{O}_2$ ,  $\text{NO}_2^-$  and  $\text{NO}_3^-$  for different fat content dairy wastewater after ACP exposure was quantitatively measured. Hydrogen peroxide levels in treated dairy effluent was in the range of 38–500  $\mu\text{M}$   $\text{H}_2\text{O}_2$  depending on treatment duration and milk fat content present in the dairy wastewater. Within 5 min of plasma treatment, significantly higher concentration of 500  $\mu\text{M}$  of  $\text{H}_2\text{O}_2$  was detected in 0.2 g/L milk fat content dairy wastewater samples (**Figure 7.5A**). These finding correlated to the bacterial inactivation studies, where increasing plasma exposure resulted in increased bacterial inactivation and showed linear correlation to the concentration of  $\text{H}_2\text{O}_2$  generated in the solution. Very low concentrations of  $\text{H}_2\text{O}_2$  were available in 2 g/L and 4 g/L milk fat dairy wastewater for contact with the bacterial cells, reflecting the ability of this complex lipid rich solution to scavenge large amounts of  $\text{H}_2\text{O}_2$ .

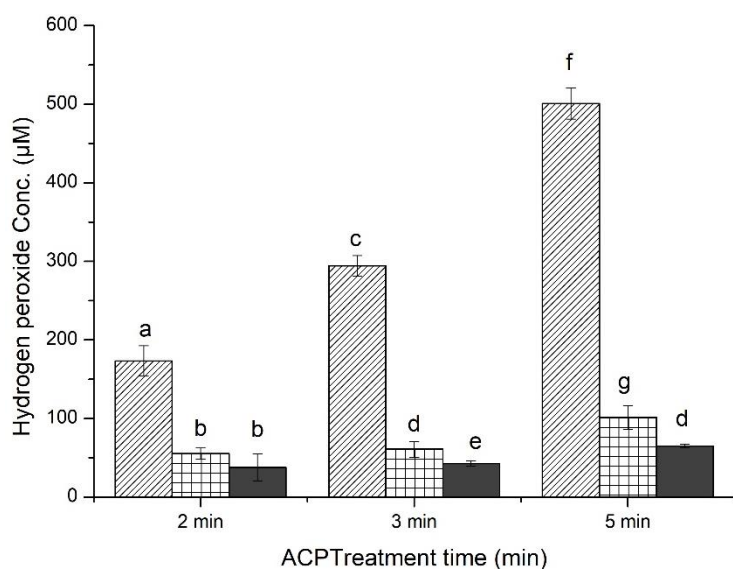

**(A) Hydrogen peroxide**

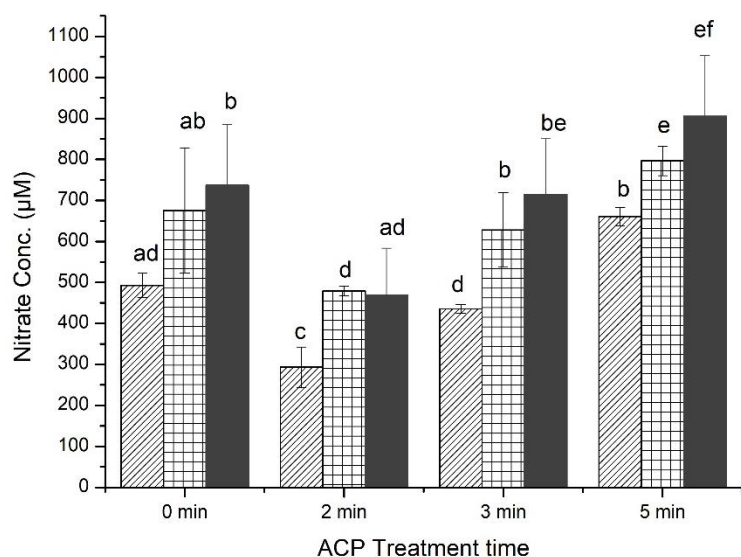

**(B) Nitrate**

**Figure 7.5: Generation of (A) Hydrogen peroxide and (B) Nitrate in model dairy wastewater after ACP treatment. (▨) 0.2 g/L (▩) 2 g/L (■) 4 g/L**

**Vertical bars represent standard deviation. Column with different letters indicate a significant difference between milk fat content and treatment time ( $p < 0.05$ ).**

The concentration of nitrate is presented in **Figure 7.5B**, which was higher in 4 g/L and 2 g/L milk fat content dairy wastewater samples and increased after ACP exposure: for treatment time of 3 min the concentration of  $\text{NO}_3^-$  reached values of 715  $\mu\text{M}$  and 627  $\mu\text{M}$ . The

complexity of initial dairy wastewater samples, consisting of high proteins, fats, lipids contributes to overall nitrogen content leading to higher nitrate concentration after plasma treatment.

Reactive species in this study were recorded immediately after ACP treatment (including post treatment retention time). Both plasma reactive species generated; hydrogen peroxide and nitrates are long lived species which showed treatment time dependence, which could improve the microbicidal effect. Previous studies from this DBD-ACP system, demonstrated stable concentration of H<sub>2</sub>O<sub>2</sub> in PBS for several weeks (Boehm *et al.*, 2016). Further work from Julák *et al.* (2012b) showed persistent microbicidal effect in water exposed to the corona discharge during 4 weeks of storage. Although ozone (O<sub>3</sub>) completely and H<sub>2</sub>O<sub>2</sub> almost disappears, the plasma treated water remains antimicrobial for one week or more following its initial exposure to plasma. This study showed increasing concentration of generation of hydrogen peroxide and nitrates however, further studies are required to determine long term stability of ACP in nutrient rich treatment samples like food industry wastewaters.

### **7.6 Inactivation of *B. megaterium* spores in model dairy and meat wastewater**

Bacterial spores are highly resistant to environmental stress including heat, UV radiation, desiccation, pH change or strong oxidisers. The structure of complexity and chemical composition of spores render the bacterial spores resistance against many disinfection agents (Granger *et al.*, 2011; Setlow, 2001). *B. megaterium* spores were used as a working alternative and challenge model in lieu of *Cryptosporidium* oocysts (Garvey *et al.*, 2013). The spores were suspended in wastewaters and subjected to continuous ACP treatment. The influence of bacterial physiological state of *B. megaterium* on decontamination efficacy of ACP treatment was evident in the case of treatment of inoculated in wastewater. Significant difference ( $p < 0.05$ ) in sensitivity was observed between *B. megaterium* vegetative cells and

its spores to ACP treatment. Plasma exposure of 1 min resulted in  $\pm 2.50 \text{ Log}_{10} \text{ CFU/ml}$  reduction in vegetative population while no significant reduction was observed in spore population ( $p>0.05$ ). Further exposure for 5 min led to complete inactivation of vegetative cells whereas spore population was reduced by  $\pm 1.9 \text{ Log}_{10} \text{ CFU/ml}$  (**Figure 7.6**).

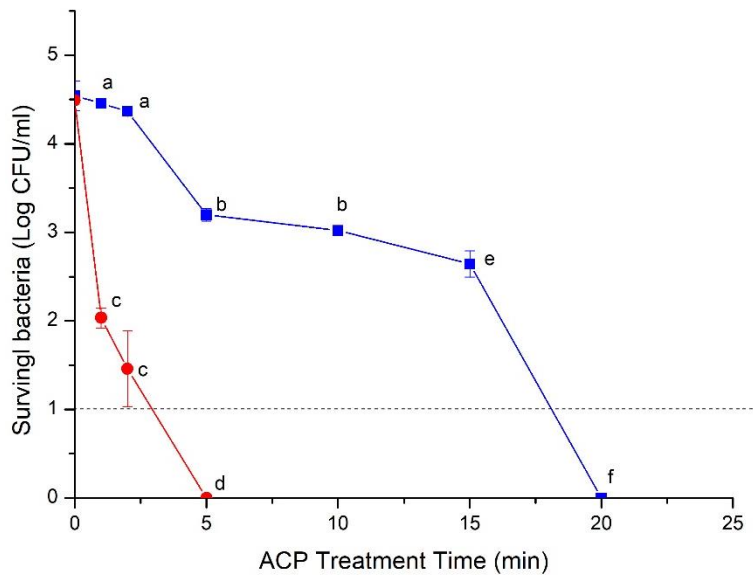
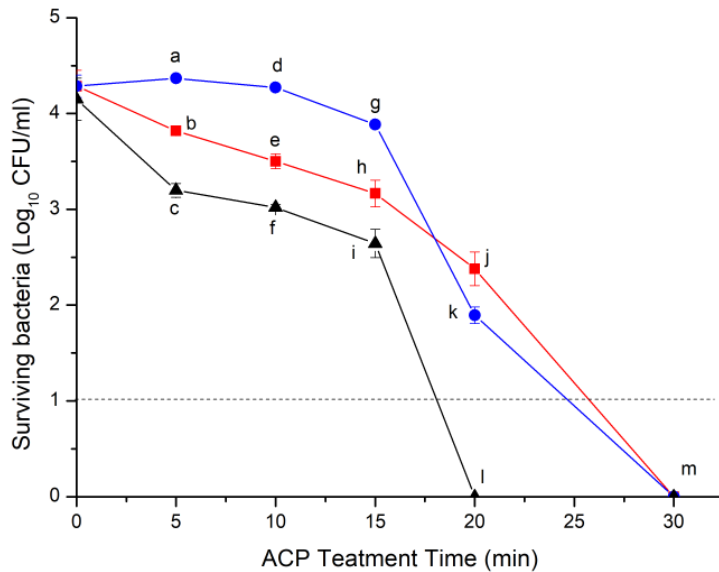

**Figure 7.6: Time depended inactivation of stationary phase *B. megaterium* (●) vegetative cells and (■) spores by ACP treatment at 80 kV.**

**Dotted line indicates limit of detection (1  $\text{Log}_{10} \text{ CFU/ml}$ ). Vertical bars represent standard deviation. Column with different letters indicate a significant difference between bacterial cells and treatment time ( $p<0.05$ ).**

A strong influence of plasma exposure on bacterial spore inactivation efficiency was noted in three different media: PBS, model dairy and meat wastewater. The order of bacterial spore's sensitivity to ACP treatment was as follows: PBS > meat wastewater > dairy wastewater. Based on the finding of this study, ACP treatment for 20 min at 80 kV was required for complete inactivation of bacterial spores suspended in PBS while in case of model meat and dairy wastewater, despite  $2 \pm 0.2 \text{ Log}_{10} \text{ CFU/ml}$  of bacterial spore reduction, a considerable proportion of spores remained viable even after ACP exposure of 20 min (**Figure 7.7**).

However, extending plasma treatment time to 30 min yielded comparable results for all media with total inactivation of bacterial spores. The complexity of high organic environment of dairy and meat media provides a protective effect against the action of plasma generated reactive species. Similarly, the effect of bacterial substrate on ACP inactivation efficacy was recorded by Boxhammer *et al.*, (2012) and Ziuzina *et al.*, (2015).



**Figure 7.7: ACP inactivation of *B. megaterium* spores suspended in (▲) PBS (■) model meat wastewater (●) model dairy wastewater.**

**Dotted line indicates limit of detection (1 Log<sub>10</sub> CFU/ml). Vertical bars represent standard deviation. Column with different letters indicate a significant difference between media and treatment time (p<0.05).**

Several chemical reactions and reactive species generated by ACP treatment play a role in plasma interaction with spores. Plasma exposure can cause several morphological and functional damage of the macromolecules including enzymes and membranes by reactive species that diffuse into the spore cells and causes inactivation which hinders the spore germination process. Research have indicated the treatment of *B. subtilis* spores with oxidising agents lead to the damage of inner membrane and spore proteins, which are essential for spore viability making them sensitive to subsequent stress (Cortezzo *et al.*,



2004). Van Bokhorst-van de Veen *et al.* (2015) reported distinct morphological changes including etching effects and the appearance of rough *B. cereus* spore surfaces observed by SEM after 20 min of treatment with nitrogen plasma.

### 7.7 Safety profile of ACP treated wastewater

The eco-toxicity tests employed in this study include some widely standardised short-term methods used to estimate the acute or chronic toxicity of chemical toxicants to aquatic ecology. A difference in sensitivity was observed to ACP treated model meat or dairy wastewater with different organisms as follows: PLHC-1 > RTG-2 ≥ *Daphnia magna*. The cytotoxicity results expressed as EC<sub>50</sub> values in **Table 7.2**, showed higher dose and exposure time dependent responses, with greater effect at higher concentrations (10-20%).

**Table 7.2: EC<sub>50</sub> values of ACP treated water wastewater for cytotoxicity test**

Treatment sample	ACP treatment time (min)	Cell line	Endpoint	EC <sub>50</sub> (% v/v)
Meat wastewater	5 min	PLHEC-1	AB	3.5 (2.2 - 4.7)
			NR	2.1 (0.0- 10.3)
		RTG-1	AB	6.9 (3.9 – 11.6)
			NR	8.7 (7.2 – 9.9)
	10 min	PLHEC-1	AB	3.3 (2.0 – 4.0)
			NR	-
		RTG-1	AB	6.2 (4.2 – 8.6)
			NR	6.4 (4.3 – 8.6)
Dairy wastewater	5 min	PLHEC-1	AB	5.2 (4.7 – 5)
			NR	6.9 (4.8 - 8.9)
		RTG-1	AB	7.0 (6.1 – 7.7)
			NR	7.3 (2.5 – 19)
	10 min	PLHEC-1	AB	3.6 (2.3 – 4.4)
			NR	5.5 (3.8 – 7.0)
		RTG-1	AB	2.4 (0.3 – 6.6)
			NR	7.8 (7.8 – 8.0)

EC<sub>50</sub> values and corresponding 95 % confidence intervals in parentheses; AB: Alamar

Blue; NR: Neutral Red

The untreated dairy and meat wastewater showed toxic effect on both fish cell lines and *D. magna* (except *D. magna* in model dairy wastewater) with 24 h of exposure. Model meat and dairy wastewater were plasma treated at 80 kV for 5 and 10 min with 10 min PTRT. Concentration and treatment time dependent cytotoxicity of plasma treated wastewater was observed in both cell lines where higher toxicity (i.e. >50%) was observed for concentrations above 10% (**Figures 7.8 and 7.9**).

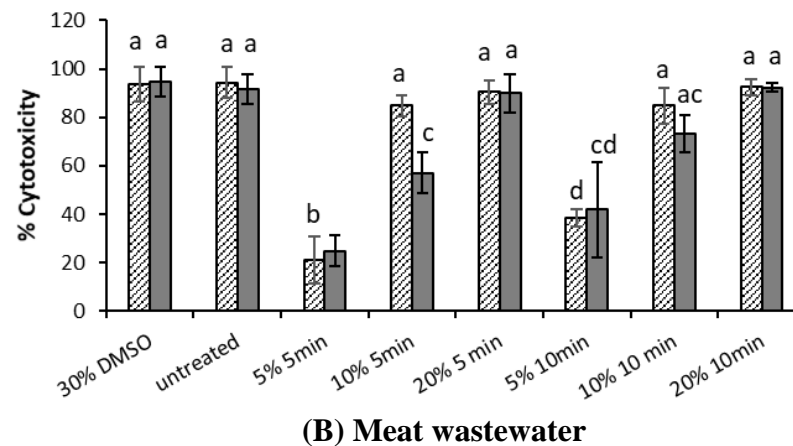
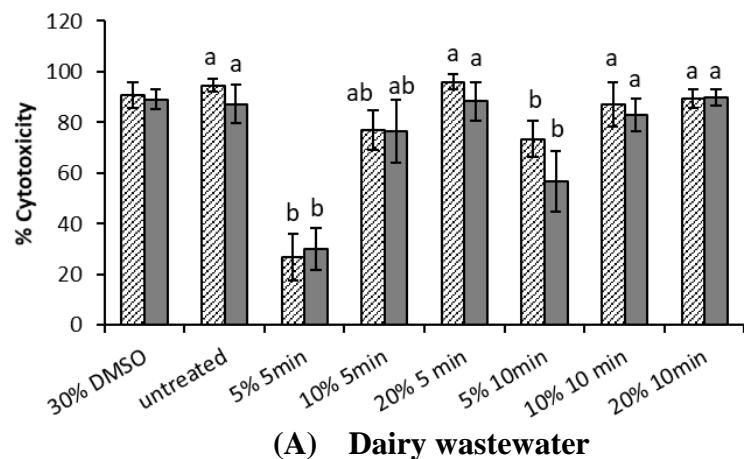

**Figure 7.8: Percentage cytotoxicity of RTG-2 cells after 24 h exposure to model dairy and meat wastewater treated with plasma at 80 kV for 5 and 10 min. ▨ Alamar blue ■ Neutral red. Vertical bars represent standard deviation. Column with different letters indicate a significant difference between controls and ACP treated samples ( $p < 0.05$ ).**

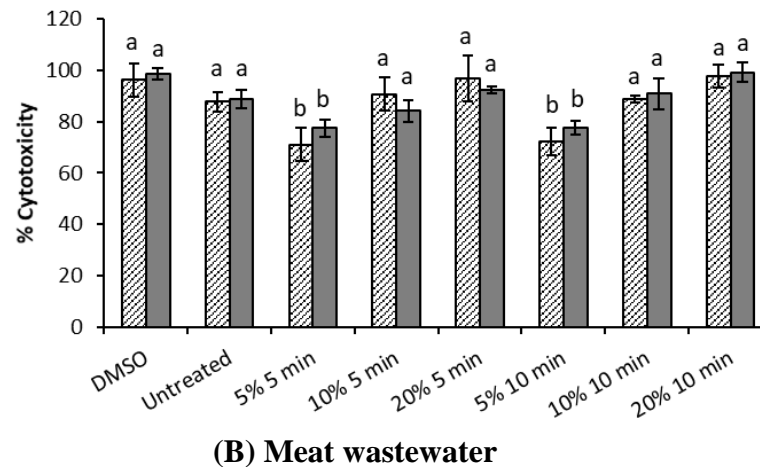
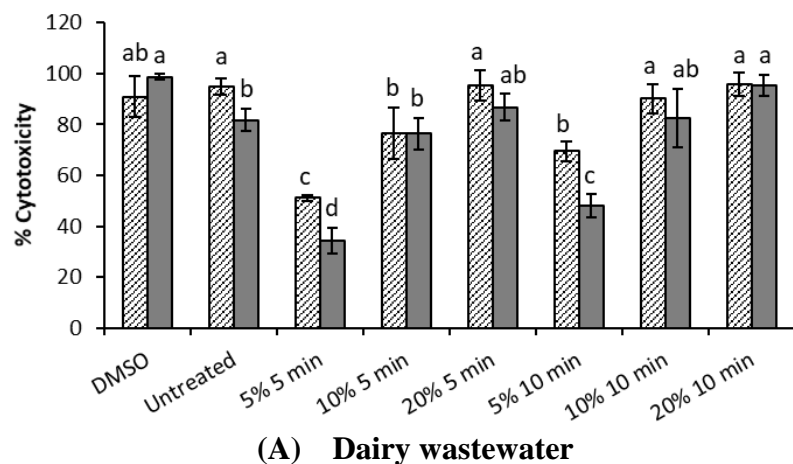

**Figure 7.9: Percentage cytotoxicity of PLHC-1 cells exposed to different concentrations of model dairy and meat wastewater treated with plasma at 80 kV for 5 and 10 min. ▨ Alamar blue ■ Neutral red. Column with different letters indicate a significant difference between controls and ACP treated samples ( $p < 0.05$ ).**

The *Daphnia magna* 24 h and 48 h mortality test with ACP wastewater samples is shown in **Figure 7.10**. A 10% effect in *Daphnia* test (EC<sub>50</sub>) indicates toxic activity. The EC<sub>50</sub> values of *D. magna* acute toxicity test after 24 and 48 h exposure to model wastewater are shown in **Table 7.3**.

**Table 7.3: EC<sub>50</sub> values of ACP treated model wastewater for acute daphnia toxicity test**

Treatment sample	ACP treatment time (min)	Period of exposure (h)	EC <sub>50</sub> (% v/v)
<b>Meat wastewater</b>	5	24	9.78
		48	7.58
	10	24	6.06
		48	5.10
<b>Dairy wastewater</b>	5	24	9.81
		48	9.50
	10	24	5.26
		48	5.26

Following ACP treatment for either 5 or 10 min, the toxicity was reduced by 100% and 73% for a 5% concentration of treated wastewater after 24 h *D. magna* exposure. Effects ranged from slight (26%) to high (100%) dependent on the concentration of ACP treated wastewater included. However, significant toxicity for all concentrations  $\leq 10\%$  of ACP treated wastewater was observed after 48 h exposure. Release parameters to yield appropriate dilution of treated wastewaters may be manipulated to exploit the ability of ACP to decontaminate wastewater streams, whilst maintaining a safe eco-toxicity profile for aquatic species.

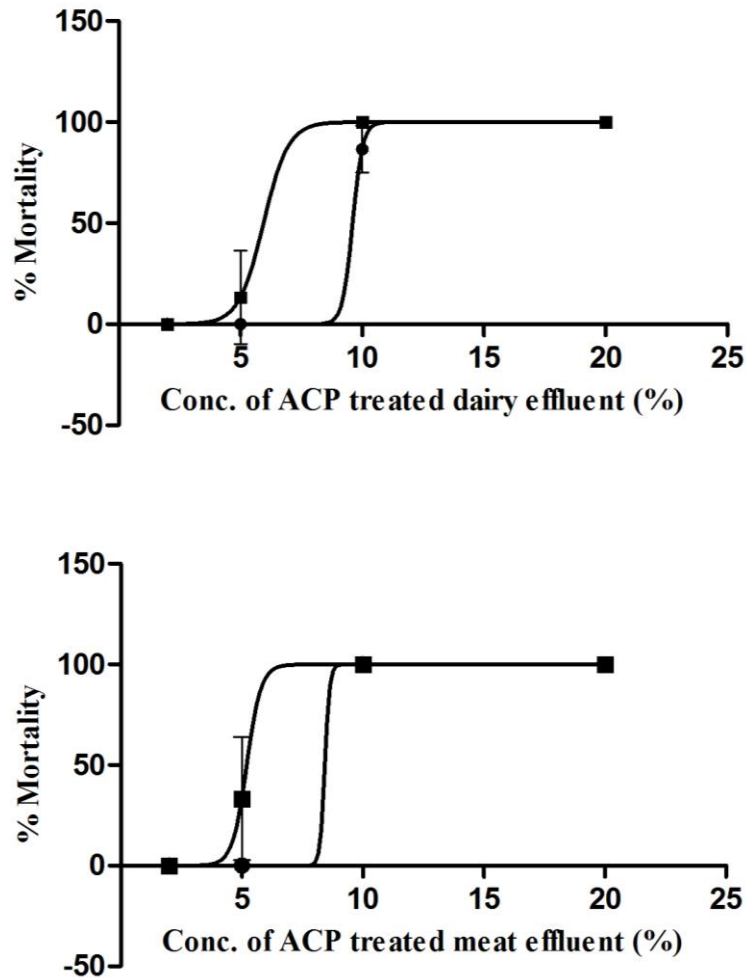

**Figure 7.10: Percentage mortality or immobilisation after 48 h exposure to model wastewater plasma treated using DBD-120 system at 80 kV for (●) 5 min (■) 10 min with 10 min of PTRT.**

Research by da Costa *et al.* (2014) demonstrated chlorine can exhibit acute high toxicity for aquatic organisms; disinfection of the wastewater with 2.5 mg/L Cl<sub>2</sub> resulted in toxicity to cladocerans and fish. According to Watson *et al.* (2012), the combined activity of residual chlorine and variety of disinfection by products left in the solution further contribute to toxicity in an aquatic system. Petala *et al.* (2008) evaluated the efficiency of ozone in wastewater treatment at different end-points and physiological properties. The ozonation of

pre-concentrated samples increased the toxic potential of secondary wastewater up to 100% after ozonation with 8.0 mg/L O<sub>3</sub> for 5 min. The mutagenic activity of the treated wastewater was also increased after ozonation with low ozone doses and contact time less than 5 min, indicating that the ozone conditions strongly affect the formation of ozone-by-products. Despite the increased interest in the development of the non-thermal oxidative processes (corona plasma discharge, UV combined H<sub>2</sub>O<sub>2</sub>) for decontamination purposes there is very little research done on potential toxicological issues associated with the use of these new technologies. In particular, ACP is considered as an efficient method for degradation of a wide variety of organic pollutants, pesticides and for microbial control. The presence of nitric and nitrous acids drastically reduces the pH of the test sample which plays an important role in bacteria inactivation but may also play a role in toxicity (Ikawa *et al.*, 2010). Additionally, the intracellular pH in bacteria plays a major role in cell function which affects its enzyme activity, reaction rates, protein stability as well as structure of nucleic acids (Bourke *et al.*, 2017). Studies by Hayes *et al.* (2013) demonstrated considerable cyto-eco-toxic end points that varied widely depending on treatment parameters and gas used for the plasma treatment. The hydrogen peroxide generated from plasma exposure plays pivotal role in cytotoxicity in combination other plasma-generated species such as peroxyxynitrite, peroxyxynitrate (Boehm *et al.*, 2017). Several reactive species and biological relevant factors are generated in plasma discharge, which differ in response to plasma device and treatment conditions. In the current study, plasma treatment of the model meat and the dairy wastewater was a function of controllable parameters and was efficient in inactivating the key bacterial populations. However, slight toxicity to biological species tested was found. Manipulation of release rate and patterns could present a means to exploit the advantages of ACP for food sector

wastewater treatment for microbiological safety and reduction of eco-toxicity of wastewater, whilst preventing longer term eco-toxic effects. Mecha *et al.* (2016) showed the toxicity of the treated wastewater highly depended at which the treatment of wastewater was applied i.e. raw wastewater, primary or after secondary treatment and species tested. Removal of organic and inorganic substances from the wastewater significantly reduced the toxicity level and enhanced biodegradability.

## **7.8 Conclusion**

In conclusion, the study showed proof-of-principle on safe treatment of food sector wastewaters using ACP for decontamination, with useful efficacy within short periods of both treatment and retention times. The efficiency of ACP varies with experimental parameters, target wastewater composition and the physiological state of the microorganism. ACP treatment was shown as a promising technology for reduction and complete inactivation of key indicator microorganisms in model dairy and meat wastewater. Depending on the microorganism target, 5 min of ACP treatment at 80 kV with 10 min of PTRT was sufficient for effective elimination of monoculture bacteria in both model wastewaters while mixed culture challenges posed greater resistance to ACP treatment. This was overcome by simply prolonging the treatment time which effectively eliminated all bacterial strains from model dairy wastewater. Based on the results and process parameters obtained from this study using a lab scale DBD system, ACP shows potential for scale up to larger industrial installations. Retention time and treatment time emerged as critical parameters in bacterial inactivation efficiency by ACP, which is important for design and development of efficient wastewater treatment solutions.

Whilst ACP treatment reduced the toxicity of the food sector wastewaters up to 24 hours exposure, a prolonged contact of up to 48 hours was toxic to *Daphnia*. The test species selected as eco-toxicity biomarkers are considered sensitive organisms and may not mimic environmental conditions closely enough to accurately predict anthropogenic contamination. Therefore, it is recommended to employ a wider variety of biological test species for conclusive results in addition to variable ratios of treated wastewater concentrations and times to progress how this technology can be safely deployed.

**The following paper has been published from this study:**

**Patange, A.,** Boehm, D., Giltrap, M., Lu, P., Cullen, P. and Bourke, P. (2018). Assessment of the disinfection capacity and eco-toxicological impact of atmospheric cold plasma for treatment of food industry effluents. *Science of The Total Environment*, 631-632, pp.298-307. <https://doi.org/10.1016/j.scitotenv.2018.02.269>.



## **Chapter 8 Overall Discussion, Conclusions and Future recommendations**

Food spoilage is a serious problem for the food industry as it renders products unacceptable for human consumption with the accompanying economic loss. Consumer demand for healthy minimally processed preservative free foods is high and on the rise. Thus, the key goal for the food industry is to seek ways to improve processing technology and find innovative solutions to address the combined requirements of guaranteed food safety, minimising microbial and chemical spoilage, whilst maintaining the quality of the product. Atmospheric cold plasmas have rapidly evolved as a technology for microbial decontamination with potential applications in Agri-Food industries. The overall objective of the research was to study microbial responses to Atmospheric Cold Plasma using DBD systems in food processing, with regards to understanding mechanism of inactivation. For this purpose, this work integrates ‘dry’ gaseous atmospheric cold plasma dielectric cold plasma system and ‘wet’ submerged dielectric barrier system based upon cold plasma discharge which could be potentially implicated into the food processing industries. Several experimental treatments were carried out in model and real food products to evaluate the decontamination potential of the plasma systems in general. For better understanding of the inactivation mechanism, role of the plasma reactive species and the influence of food substrate, storage temperature conditions and microbial stress conditions were investigated. The antimicrobial efficacy of ACP technology was investigated using DBD-ACP systems; range of critical control parameters were analysed to find best processing conditions to achieve high inactivation. Preliminary studies with planktonic bacterial population of spoilage and pathogenic bacteria demonstrate that the antimicrobial efficacy of cold plasma treatment was greatly affected by the applied voltage level, treatment time and post treatment

storage time. Higher inactivation efficiency of ACP against planktonic cells was observed with increase in applied voltage levels or extended plasma treatment time. The reactive species generated by ACP play an important role in bacterial inactivation efficacy of plasma. Concentration of different reactive species (ROS, RNS, ozone) increased with plasma treatment time and demonstrated significant co-relation between bacteria inactivation by ACP and reactive species was observed. Further the in-package treatment and post treatment storage time (PTST) played a critical role in bacterial inactivation efficacy. A range of PTST was evaluated, where 24 h PTST was found to be most compatible for further experiments as it allowed longer interaction between the bacteria and the reactive species inside the sealed pack thus retaining efficacy against the target. Although the bacterial inactivation was higher with longer post treatment storage, the effect of short-lived species and charged particles were apparent in conjunction with other parameters, such as voltage and treatment time demonstrating significant microbial reduction within short post treatment time.

Microbial inactivation not only depended on the system and treatment parameters but also on the characteristics of the treatment product. To simulate real fresh produce processing conditions, a model broth was used to analyse the influence of substrate components on antimicrobial efficacy of treatment. The media employed had a strong influence over the ACP bacterial inactivation, showing significant difference in rate of bacterial inactivation when treated in PBS, model meat and lettuce media. The product characteristics greatly influenced the bacterial inactivation effects of ACP. Components of the nutrient rich model meat and lettuce medium may scavenge the plasma generated reactive species and pose a protective effect against the antimicrobial action of the reactive species.

Most bacterial population can attach and produce biofilms on a wide variety of different surfaces in the food-processing environment. Biofilms are persistent form of bacteria which are more resistant to several environmental conditions and the actions of antimicrobial treatments. Rapid inactivation of challenge mono species biofilms of pathogenic and spoilage bacteria formed in model lettuce broth was achieved with 1 min of ACP treatment. Furthermore, the dual-species biofilm is known to represent more challenging environment than single species biofilm. Both *L. monocytogenes* and *P. fluorescens* as dual species biofilm formed in lettuce broth showed significant reduction in viable as well as metabolic activity of the bacterial population after ACP treatment of 60 s and 24 h PTST. The results obtained demonstrate that ACP treatment obstruct the association capacity between the mixed biofilms, giving rise to mixed biofilm that is significantly ( $p < 0.05$ ) less resistant to ACP. However, when challenge dual-species microorganisms were inoculated on lettuce, an extended treatment time (300 s) was necessary in order to achieve significant reductions of the bacterial populations. Interspecies interaction along with complex substrate surface seems to have effect on antimicrobial resistance of biofilm of each individual species. In most cases, due to the rough surface structure or deep cuts of fresh produce, microorganism may strongly adhere or internalise into the tissue, shielding the bacteria from plasma generated reactive species, which are responsible for the inactivation of microorganisms.

These studies also demonstrated that produce matrix and storage conditions such as refrigeration temperatures and pH had interactive effects on bacterial proliferation, stress response and susceptibility to the ACP treatment. ACP treatment was effective to inactivate *L. monocytogenes* and *P. fluorescens* populations exposed to prior acid/cold stress conditions that are commonly encountered in food processing environment. *L. monocytogenes* exposed

to cold stress (4 °C) demonstrated higher resistance than non-stressed control cells and *P. fluorescens*. This study demonstrated that despite low temperature of 4°C, resistance of *L. monocytogenes* to ACP treatment increased with increased incubation time which could be attributed to the microbial stress responses during leaf inoculation and storage conditions.

During this study the contributions of the putative components of the stress-some to the  $\sigma^B$  mediated stress response were tested and unique physiological, cellular and genomic responses were obtained after sub-lethal ACP conditions. Nine knock-out mutants were chosen in this study to investigate those modified genes effects during the post-treatment storage procedure after ACP treatment. ACP treatment effectively reduced *L. monocytogenes* and its mutant within 3-5 min of treatment under stressed/non-stressed/biofilm conditions. Pre-adaptation to mild acid or cold stress did not enhance survival of any strain following exposure to plasma treatment. Moreover, gene expression analysis of *L. monocytogenes* EGD-e indicated *sigB*, *prfA*, *rsbR*, *lmo0799*, *gadD* genes, which are notably involved in multiple stress conditions and virulence, were up-regulated following exposure to sub-lethal ACP treatment. This study provides a baseline in evaluating how stress associated genes in *L. monocytogenes* respond to gas plasma treatments and the provided information can contribute to the optimisation of plasma processing conditions also in view of preventing the cross-protection towards other stresses that microorganism may encounter during food processing.

This study also evaluated water-based decontamination approach for inactivation of bacterial population from fresh produce and in the wash-water used for fresh produce processing using submerged Dielectric Barrier plasma (DBD)-ACP system. These findings demonstrate aqueous plasma treatment can effectively reduce viable counts of pathogenic and spoilage microorganisms attached on lettuce. ACP functionalised water was efficient to control *L.*

*innocua* while reducing *P. fluorescens* population below detection limit from lettuce, as well as from the wash water used for the treatment. In addition, micro-bubble along with high speed agitation helped distribution of the active agents and enhanced microbial: reactive species interactions. The treatment with plasma functionalised water for 1 and 3 min decreased the bacterial population without any visible damaging effect on the lettuce surface. Considering the potential impacts of industrial wastewater effluents on the environment, atmospheric cold plasma (ACP) was evaluated for control of key microbial indicators encountered in food industry effluent. The study demonstrated inactivation of principle indicator microorganisms suspended in food processing wastewaters using ACP system. Results show that initial bacterial indicators, physiological type of bacteria, treatment duration, applied voltage, structure of the supporting medium play an important role in antimicrobial efficacy of ACP treatment. Greater inactivation efficiency was achieved with increased treatment time and voltage level along with the PTRT for all the microorganisms (mono/mixed). Findings show that ACP could be adapted to disinfect wastewater at varying process parameters. Besides the reduction of microbial contamination, care must be taken to evaluate eco-toxicity of the treated product before released into the environment. The wastewater effluents from the food processing industries even after treatment are a complex matrix that not only interacts with each other but also reacts with the receiving water when released into the aquatic water source. Therefore, eco-toxicity testing of the treated wastewater was designed specifically to measure environmental sustainability and safety measures of the ACP treated wastewaters using aquatic biomarkers such as PLHC-1, RTG-2, *Daphnia magna*. Based on toxicity tests, the untreated wastewater was found to be highly toxic to the aquatic ecology, ACP treatment for 5 min help reduce the toxicity of the effluents

up to 24 h. Concentration and treatment time dependent cytotoxicity of plasma treated effluent was observed in both the fish cells and *D. magna*.

### **Conclusions:**

Overall a number of conclusions regarding the use of ACP as a microbicidal process and its application for food products can be made from this study:

- Atmospheric cold plasma treatment was highly effective in eliminating key planktonic pathogens and spoilage causing bacteria associated with food industry. The extrinsic control parameters played an important role in ACP inactivation efficacy by producing different concentration of reactive species. Overall, a higher voltage in combination with post treatment storage time enhanced bacterial inactivation efficacy, reducing microbial population within short treatment time.
- The optimum treatment time was dependent on type of bacteria and the microbial challenge presented. Inactivation was affected by interspecies interaction between pathogenic and spoilage bacteria in biofilm, biofilm setup conditions, temperature and substrate surface. ACP effectively inactivated mono and dual culture biofilms, however, an extended treatment was required to attain substantial reduction of cells present in the dual biofilms developed at 4 °C attached to lettuce surface as an example of complex organic surface and environmental stress conditions.
- ACP treatment effectively reduced *L. monocytogenes* and its mutants associated with stress by 3-5 min of treatment under stressed/non-stressed/biofilm conditions. The sub-lethal ACP treatment increases the gene expression of stress associated while longer treatment significantly reduced and downregulated stressosome and virulence genes. Treatment time plays an important role in gene expression of stress genes in

microorganisms, the influence of ACP exposure time needs to be taken into account when optimising ACP treatment parameters.

- Aqueous plasma functionalised water was effective to reduce viable microorganisms attached on lettuce. Micro-bubbles and agitation enhanced microbial: reactive species interactions. Microbial load in process wash water was continuously decreased. Minimal or no effect of pH on ACP bacterial inactivation efficacy. Pre-washing the lettuce in plasma functionalized water could be efficient replacement for commercial processing line
- Effective to inactivate key mono/mixed indicator bacteria and reduce bacterial spores from model dairy and meat wastewater. Plasma treatment time and post treatment retention time played a critical role in bacterial inactivation efficacy.
- The media employed also had a strong influence on efficacy and interacts with treatment times for all challenge microorganisms selected in model meat and dairy wastewater. Assessment of reactive species showed that low concentrations of hydrogen peroxide and nitrates were generated in high milk fat content dairy wastewater than initial dairy wastewater. The high nutrient and fat content are likely to scavenge many of the plasma generated reactive species and thus pose a protective effect against antimicrobial action of the reactive species generated in the plasma.
- ACP Treated samples displayed limited effect on aquatic test species exposed for 24 h exposure compared to untreated control samples. ACP has shown a promising alternative for the wastewater treatment. Rapid decontamination times could be useful for rapid mode of treatment in industries.

### **Future recommendations:**

ACP treatment is a promising tool for decontamination of biological targets. Overall, the results show potential of high voltage in-package atmospheric cold plasma treatment in reducing bacteria on food products or food processing environments. The results indicate the importance of product and surface characteristics, nutrient content, food surface geometry, bacterial population involved, and the strength of the bacterial attachment needs to be considered when designing future optimisation procedures. Although significant reduction of reproducibility and metabolic activity of cells in bacterial biofilms were obtained, the inactivation efficacy patterns and interspecies interaction of ACP on morphological and overall framework of mono/multi bacterial biofilm still needs to be explored.

The present study investigated the role of several sub-lethal and lethal ACP stress on stress associated genes of *L. monocytogenes*. The results show that plasma exposure to sub-lethal conditions can have significant effect on gene expression of stress and virulence associated genes. However, the role of *prfA* as well as the identification of genes from the *sigB* regulon which play a role during stress conditions and cold plasma treatment requires further investigation. Additional research is needed to better understand the functional genomics and/or proteomics induced in microorganisms upon exposure to ACP that can attribute to a specific change in function, virulence or phenotype.

The findings with short term eco-toxicity tests showed concentration and treatment time dependent cytotoxicity of plasma treated effluent to aquatic biomarkers such as PLHC-1, RTG-2, *Daphnia magna*. The study suggests the need to employ wider variety of in vitro test battery such as AlgalTox test, Zebrafish embryos test and Microtox test for better understanding of toxicity properties and complete evaluation of long-term effects of plasma



treated water. The effects of chronic exposure of plasma functionalised water on reproduction, growth, survival and other parameters over one or more generations of population of test organisms could provide holistic approach in establishing long term safe environmental concentrations of plasma treated water before release into the environment.

## References

- Abee, T., Wouters, J.A., 1999. Microbial stress response in minimal processing. *Int. J. Food Microbiol.* 50, 65–91. [https://doi.org/10.1016/S0168-1605\(99\)00078-1](https://doi.org/10.1016/S0168-1605(99)00078-1)
- Abram, F., Starr, E., Karatzas, K.A.G., Matlawska-Wasowska, K., Boyd, A., Wiedmann, M., Boor, K.J., Connally, D., O’Byrne, C.P., 2008. Identification of components of the sigma B regulon in *Listeria monocytogenes* that contribute to acid and salt tolerance. *Appl. Environ. Microbiol.* <https://doi.org/10.1128/AEM.00442-08>
- Abramzon, N., Joaquin, J.C., Bray, J., Brelles-Marino, G., 2006. Biofilm Destruction by RF High-Pressure Cold Plasma Jet. *IEEE Trans. Plasma Sci.* 34, 1304–1309. <https://doi.org/10.1109/TPS.2006.877515>
- Al-Hinai, M.A., Jones, S.W., Papoutsakis, E.T., 2015. The *Clostridium* sporulation programs: diversity and preservation of endospore differentiation. *Microbiol. Mol. Biol. Rev.* 79, 19–37. <https://doi.org/10.1128/MMBR.00025-14>
- Alkawareek, M.Y., Algwari, Q.T., Gorman, S.P., Graham, W.G., O’Connell, D., Gilmore, B.F., 2012. Application of atmospheric pressure nonthermal plasma for the in vitro eradication of bacterial biofilms. *FEMS Immunol. Med. Microbiol.* 65, 381–4. <https://doi.org/10.1111/j.1574-695X.2012.00942.x>
- Arana, I., Muela, A., Orruño, M., Seco, C., Garaizabal, I., Barcina, I., 2010. Effect of temperature and starvation upon survival strategies of *Pseudomonas fluorescens* CHA0: comparison with *Escherichia coli*. *FEMS Microbiol. Ecol.* 74, 500–509. <https://doi.org/10.1111/j.1574-6941.2010.00979.x>

- Arguedas-Villa, C., Stephan, R., Tasara, T., 2010. Evaluation of cold growth and related gene transcription responses associated with *Listeria monocytogenes* strains of different origins. *Food Microbiol.* <https://doi.org/10.1016/j.fm.2010.02.009>
- Arjunan, K.P., Friedman, G., Fridman, A., Clyne, A.M., 2012. Non-thermal dielectric barrier discharge plasma induces angiogenesis through reactive oxygen species. *J. R. Soc. Interface.* <https://doi.org/10.1098/rsif.2011.0220>
- Arjunan, K.P., Sharma, V.K., Ptasinska, S., 2015. Effects of atmospheric pressure plasmas on isolated and cellular DNA—a review. *Int. J. Mol. Sci.* <https://doi.org/10.3390/ijms16022971>
- Bader, H., Hoigne, J., 1981. Determination of ozone in water by the indigo method; a submitted standard method. *Ozone Sci. Eng.* <https://doi.org/10.1080/01919518208550955>
- Banach, J., Sampers, I., Van Haute, S., van der Fels-Klerx, H.J., 2015. Effect of Disinfectants on Preventing the Cross-Contamination of Pathogens in Fresh Produce Washing Water. *Int. J. Environ. Res. Public Health* 12, 8658–8677. <https://doi.org/10.3390/ijerph120808658>
- Barbera, M., Gurnari, G., 2018. Water Reuse in the Food Industry: Quality of Original Wastewater Before Treatments, in: *Wastewater Treatment and Reuse in the Food Industry*. SpringerBriefs in Molecular Science, pp. 1–16.
- Barcina, I., Arana, I., 2009. The viable but nonculturable phenotype: a crossroads in the life-cycle of non-differentiating bacteria? *Rev. Environ. Sci. Bio/Technology* 8, 245–255.

<https://doi.org/10.1007/s11157-009-9159-x>

Bárdos, L., Baránková, H., 2010. Cold atmospheric plasma: Sources, processes, and applications. *Thin Solid Films* 518, 6705–6713. <https://doi.org/10.1016/j.tsf.2010.07.044>

Barekzi, N., Akman, M.A., Laroussi, M., 2012. Inactivation pathways of reactive species generated by low temperature atmospheric pressure plasma, in: 2012 Abstracts IEEE International Conference on Plasma Science. p. 2P–134–2P–134.  
<https://doi.org/10.1109/PLASMA.2012.6383690>

Barrera, M., Mehrvar, M., Gilbride, K.A., McCarthy, L.H., Laursen, A.E., Bostan, V., Pushchak, R., 2012. Photolytic treatment of organic constituents and bacterial pathogens in secondary effluent of synthetic slaughterhouse wastewater. *Chem. Eng. Res. Des.*  
<https://doi.org/10.1016/j.cherd.2011.11.018>

Barth, M., Hankinson, T.R., Zhuang, H., Breidt, F., 2009. Microbiological Spoilage of Fruits and Vegetables, in: *Compendium of the Microbiological Spoilage of Foods and Beverages*. Springer New York, New York, NY, pp. 135–183.  
[https://doi.org/10.1007/978-1-4419-0826-1\\_6](https://doi.org/10.1007/978-1-4419-0826-1_6)

Beales, N., 2004. Adaptation of Microorganisms to Cold Temperatures, Weak Acid Preservatives, Low pH, and Osmotic Stress: A Review. *Compr. Rev. Food Sci. Food Saf.* <https://doi.org/10.1111/j.1541-4337.2004.tb00057.x>

Belessi, C.E.A., Gounadaki, A.S., Psomas, A.N., Skandamis, P.N., 2011. Efficiency of different sanitation methods on *Listeria monocytogenes* biofilms formed under various environmental conditions. *Int. J. Food Microbiol.*

<https://doi.org/10.1016/j.ijfoodmicro.2010.10.020>

Beresford, M.R., Andrew, P.W., Shama, G., 2001. *Listeria monocytogenes* adheres to many materials found in food-processing environments. *J. Appl. Microbiol.*

<https://doi.org/10.1046/j.1365-2672.2001.01330.x>

Bergholz, T.M., Bowen, B., Wiedmann, M., Boor, K.J., 2012. *Listeria monocytogenes*: Shows Temperature-Dependent and -Independent Responses to Salt Stress, Including Responses That Induce Cross-Protection against Other Stresses. *Appl. Environ. Microbiol.* 78, 2602.

Bertsch, D., Rau, J., Eugster, M.R., Haug, M.C., Lawson, P.A., Lacroix, C., Meile, L., 2013. *Listeria fleischmannii* sp. nov., isolated from cheese. *Int. J. Syst. Evol. Microbiol.*

<https://doi.org/10.1099/ijvs.0.036947-0>

Besser, R.E., Lett, S.M., Weber, J.T., Doyle, M.P., Barrett, T.J., Wells, J.G., Griffin, P.M., 1993. An Outbreak of Diarrhea and Hemolytic Uremic Syndrome From *Escherichia coli* O157:H7 in Fresh-Pressed Apple Cider. *JAMA J. Am. Med. Assoc.* 269, 2217.

<https://doi.org/10.1001/jama.1993.03500170047032>

Beuchat, L.R., 1996. *Listeria monocytogenes*: incidence on vegetables. *Food Control* 7, 223–228. [https://doi.org/10.1016/S0956-7135\(96\)00039-4](https://doi.org/10.1016/S0956-7135(96)00039-4)

Beuchat LR., 1998. Surface decontamination of fruit and vegetables eaten raw: a review.

*Food Saf. Unit World Heal. Organ. WHOFSFFOS982.*

<https://doi.org/entity/mediacentre/factsheets/fs399/en/index.html>

- Bitton, G., 2011. Wastewater microbiology. Wiley-Blackwell.
- Bitton, G., 2005. Wastewater Microbiology. John Wiley & Sons, Inc., Hoboken, NJ, USA.  
<https://doi.org/10.1002/0471717967>
- Blaschek, H., Wang, H., Agle, M., 2007. Biofilms in the food environment. Blackwell Pub.
- Boehm, D., Curtin, J., Cullen, P., Bourke, P., 2017. Hydrogen Peroxide and Beyond-the Potential of High-voltage Plasma-activated Liquids Against Cancerous Cells. Anticancer. Agents Med. Chem. 17.  
<https://doi.org/10.2174/1871520617666170801110517>
- Boehm, D., Heslin, C., Cullen, P.J., Bourke, P., 2016. Cytotoxic and mutagenic potential of solutions exposed to cold atmospheric plasma. Sci. Rep. 6, 21464.  
<https://doi.org/10.1038/srep21464>
- Bogaerts, A., Neyts, E., Gijbels, R., van der Mullen, J., 2002. Gas discharge plasmas and their applications. Spectrochim. Acta Part B At. Spectrosc. 57, 609–658.  
[https://doi.org/10.1016/S0584-8547\(01\)00406-2](https://doi.org/10.1016/S0584-8547(01)00406-2)
- Borch, E., Kant-Muermans, M.-L., Blixt, Y., 1996. Bacterial spoilage of meat and cured meat products. Int. J. Food Microbiol. 33, 103–120. [https://doi.org/10.1016/0168-1605\(96\)01135-X](https://doi.org/10.1016/0168-1605(96)01135-X)
- Boura, M., Keating, C., Royet, K., Paudyal, R., O'Donoghue, B., O'Byrne, C.P., Karatzas, K.A.G., 2016. The presence of SigB in *Listeria monocytogenes* strains EGD-e and 10403S leads to hypersensitivity to hydrogen peroxide in stationary phase under aerobic conditions. Appl. Environ. Microbiol. <https://doi.org/10.1128/AEM.00709-16>

- Bourke, P., Ziuzina, D., Han, L., Cullen, P.J., Gilmore, B.F., 2017. Microbiological interactions with cold plasma. *J. Appl. Microbiol.* <https://doi.org/10.1111/jam.13429>
- Boxhammer, V., Morfill, G.E., Jokipii, J.R., Shimizu, T., Klämpfl, T., Li, Y.-F., Köritzer, J., Schlegel, J., Zimmermann, J.L., 2012. Bactericidal action of cold atmospheric plasma in solution. *New J. Phys.* 14, 113042. <https://doi.org/10.1088/1367-2630/14/11/113042>
- Burleson, G.R., Murray, T.M., Pollard, M., 1975. Inactivation of viruses and bacteria by ozone, with and without sonication. *Appl. Microbiol.* 29, 340–4.
- Bustillo-Lecompte, C., Mehrvar, M., 2017. Slaughterhouse Wastewater: Treatment, Management and Resource Recovery. *Physico-Chemical Wastewater Treat. Resour. Recover.* doi:10.5772/65499
- Bustillo-Lecompte, C.F., Mehrvar, M., Quiñones-Bolaños, E., 2014. Cost-effectiveness analysis of TOC removal from slaughterhouse wastewater using combined anaerobic–aerobic and UV/H<sub>2</sub>O<sub>2</sub> processes. *J. Environ. Manage.* 134, 145–152. <https://doi.org/10.1016/j.jenvman.2013.12.035>
- Bustillo-Lecompte, C.F., Mehrvar, M., Quiñones-Bolaños, E., 2013. Combined anaerobic–aerobic and UV/H<sub>2</sub>O<sub>2</sub> processes for the treatment of synthetic slaughterhouse wastewater. <http://dx.doi.org/10.1080/10934529.2013.774662>.
- Callejón, R.M., Rodríguez-Naranjo, M.I., Ubeda, C., Hornedo-Ortega, R., Garcia-Parrilla, M.C., Troncoso, A.M., 2015. Reported Foodborne Outbreaks Due to Fresh Produce in the United States and European Union: Trends and Causes. *Foodborne Pathog. Dis.* <https://doi.org/10.1089/fpd.2014.1821>

- Calvo, T., Alvarez-Ordóñez, A., Prieto, M., Bernardo, A., López, M., 2017. Stress adaptation has a minor impact on the effectivity of Non-Thermal Atmospheric Plasma (NTAP) against *Salmonella* spp. *Food Res. Int.* <https://doi.org/10.1016/j.foodres.2017.09.035>
- Cameron, M., McMaster, L.D., Britz, T.J., 2008. Electron microscopic analysis of dairy microbes inactivated by ultrasound. *Ultrason. Sonochem.* 15, 960–964.  
<https://doi.org/10.1016/j.ultsonch.2008.02.012>
- Cao, S., Hu, Z., Pang, B., 2010. Optimization of postharvest ultrasonic treatment of strawberry fruit. *Postharvest Biol. Technol.* 55, 150–153.  
<https://doi.org/10.1016/j.postharvbio.2009.11.002>
- Capita, R., Alonso-Calleja, C., 2013. Antibiotic-Resistant Bacteria: A Challenge for the Food Industry. *Crit. Rev. Food Sci. Nutr.* <https://doi.org/10.1080/10408398.2010.519837>
- Capozzi, V., Fiocco, D., Amodio, M.L., Gallone, A., Spano, G., 2009. Bacterial Stressors in Minimally Processed Food. *Int. J. Mol. Sci.* 10, 3076–3105.  
<https://doi.org/10.3390/ijms10073076>
- Carpentier, B., Chassaing, D., 2004. Interactions in biofilms between *Listeria monocytogenes* and resident microorganisms from food industry premises. *Int. J. Food Microbiol.* <https://doi.org/10.1016/j.ijfoodmicro.2004.03.031>
- Casado, M.P., Macken, A., Byrne, H.J., 2013. Ecotoxicological assessment of silica and polystyrene nanoparticles assessed by a multitrophic test battery. *Environ. Int.* 51, 97–105. <https://doi.org/10.1016/j.envint.2012.11.001>
- CDC, 2018. List of Selected Multistate Foodborne Outbreak Investigations [WWW



Document]. Centers Dis. Control Prev. URL

<https://www.cdc.gov/foodsafety/outbreaks/multistate-outbreaks/outbreaks-list.html>

(accessed 7.20.18).

CDC, 2016. E.coli Foodborne Outbreak [WWW Document]. Centers Dis. Control Prev.

Natl. Cent. Emerg. Zoonotic Infect. Dis. URL <http://wwwn.cdc.gov/foodborneoutbreaks/>

(accessed 3.13.18).

Cevallos-Cevallos, J.M., Gu, G., Danyluk, M.D., van Bruggen, A.H.C., 2012. Adhesion and splash dispersal of *Salmonella enterica* Typhimurium on tomato leaflets: Effects of rdar morphotype and trichome density. *Int. J. Food Microbiol.* 160, 58–64.

<https://doi.org/10.1016/j.ijfoodmicro.2012.09.021>

Chae, M.S., Schraft, H., 2000. Comparative evaluation of adhesion and biofilm formation of different *Listeria monocytogenes* strains. *Int. J. Food Microbiol.* 62, 103–111.

[https://doi.org/10.1016/S0168-1605\(00\)00406-2](https://doi.org/10.1016/S0168-1605(00)00406-2)

Chaidez, C., Campo, N., Heredia, J.B., Angulo, L., Aguilar, G.G., Ayala-Zavala, J.F., 2012.

Chlorine, in: *Decontamination of Fresh and Minimally Processed Produce*. Wiley-Blackwell, Oxford, UK, pp. 121–133.

Chan, Y.C., Boor, K.J., Wiedmann, M., 2007.  $\sigma$ B-dependent and  $\sigma$ B-independent

mechanisms contribute to transcription of *Listeria monocytogenes* cold stress genes during cold shock and cold growth. *Appl. Environ. Microbiol.*

<https://doi.org/10.1128/AEM.00714-07>

Chang, J.-S., Lawless, P.A., Yamamoto, T., 1991. Corona discharge processes. *IEEE Trans.*

Plasma Sci. 19, 1152–1166. <https://doi.org/10.1109/27.125038>

Chaturongakul, S., Boor, K.J., 2004. RsbT and RsbV contribute to  $\sigma^B$ -dependent survival under environmental, energy, and intracellular stress conditions in *Listeria monocytogenes*. *Appl. Environ. Microbiol.* <https://doi.org/10.1128/AEM.70.9.5349-5356.2004>

Chaturongakul, S., Raengpradub, S., Wiedmann, M., Boor, K.J., 2008. Modulation of stress and virulence in *Listeria monocytogenes*. *Trends Microbiol.* <https://doi.org/10.1016/j.tim.2008.05.006>

Chen, J.-Q., Regan, P., Laksanalamai, P., Healey, S., Hu, Z., 2017. Prevalence and methodologies for detection, characterization and subtyping of *Listeria monocytogenes* and *L. ivanovii* in foods and environmental sources. *Food Sci. Hum. Wellness* 6, 97–120. <https://doi.org/10.1016/j.fshw.2017.06.002>

Chen, J.P., Yang, L., Wang, L.K., Zhang, B., 2006. Ultraviolet Radiation for Disinfection, in: *Advanced Physicochemical Treatment Processes*. Humana Press, Totowa, NJ, pp. 317–366. [https://doi.org/10.1007/978-1-59745-029-4\\_10](https://doi.org/10.1007/978-1-59745-029-4_10)

Cheng, C., Liye, Z., Zhan, R.-J., 2006. Surface modification of polymer fibre by the new atmospheric pressure cold plasma jet. *Surf. Coatings Technol.* 200, 6659–6665. <https://doi.org/10.1016/j.surfcoat.2005.09.033>

Chirokov, A., Gutsol, A., Fridman, A., 2005. Atmospheric pressure plasma of dielectric barrier discharges. *Pure Appl. Chem.* 77. <https://doi.org/10.1351/pac200577020487>

Chmielewski, R.A.N., Frank, J.F., 2003. *Biofilm Formation and Control in Food Processing*

Facilities. *Compr. Rev. Food Sci. Food Saf.* <https://doi.org/10.1111/j.1541-4337.2003.tb00012.x>

Ciofu, O., Tolker-Nielsen, T., 2010. Antibiotic Tolerance and Resistance in Biofilms, in: *Biofilm Infections*. Springer New York, New York, NY, pp. 215–229.  
[https://doi.org/10.1007/978-1-4419-6084-9\\_13](https://doi.org/10.1007/978-1-4419-6084-9_13)

Collins-Thompson, D.L., Rodriguez Lopez, G., 1980. Influence of sodium nitrite, temperature, and lactic acid bacteria on the growth of *Brochothrix thermosphacta* under anaerobic conditions. *Can. J. Microbiol.* 26, 1416–1421.

Commission of the European Communities, 2008. EU (2013) Guidance Document on *Listeria monocytogenes* shelf-life studies for ready-to-eat foods. Brussels.

Conibear, T.C.R., Collins, S.L., Webb, J.S., 2009. Role of Mutation in *Pseudomonas aeruginosa* Biofilm Development. *PLoS One* 4, e6289.  
<https://doi.org/10.1371/journal.pone.0006289>

Cortezzo, D.E., Koziol-Dube, K., Setlow, B., Setlow, P., 2004. Treatment with oxidizing agents damages the inner membrane of spores of *Bacillus subtilis* and sensitizes spores to subsequent stress. *J. Appl. Microbiol.* 97, 838–52. <https://doi.org/10.1111/j.1365-2672.2004.02370.x>

Cotter, P.D., Gahan, C.G.M., Hill, C., 2001. A glutamate decarboxylase system protects *Listeria monocytogenes* in gastric fluid. *Mol. Microbiol.* <https://doi.org/10.1046/j.1365-2958.2001.02398.x>

Cotter, P.D., Hill, C., 2003. Surviving the Acid Test: Responses of Gram-Positive Bacteria to

Low pH. *Microbiol. Mol. Biol. Rev.* <https://doi.org/10.1128/MMBR.67.3.429-453.2003>

Cristian, O., 2010. CHARACTERISTICS OF THE UNTREATED WASTEWATER

PRODUCED BY FOOD INDUSTRY. *Analele Univ. din Oradea Fasc. Mediu.* XV.

Critzer, F.J., Doyle, M.P., 2010. Microbial ecology of foodborne pathogens associated with produce. *Curr. Opin. Biotechnol.* 21, 125–130.

<https://doi.org/10.1016/j.copbio.2010.01.006>

Critzer, F.J., Kelly-Wintenberg, K., South, S.L., Golden, D.A., 2007. Atmospheric plasma inactivation of foodborne pathogens on fresh produce surfaces. *J. Food Prot.* 70, 2290–6.

Crowe, S.J., Mahon, B.E., Vieira, A.R., Gould, L.H., 2015. Vital Signs: Multistate Foodborne Outbreaks — United States, 2010–2014. *MMWR. Morb. Mortal. Wkly. Rep.*

<https://doi.org/10.15585/mmwr.mm6443a4>

Cullen, P.J., Norton, T., 2012. Ozone Sanitisation in the Food Industry, in: *Ozone in Food Processing*. Wiley-Blackwell, Oxford, UK, pp. 163–176.

<https://doi.org/10.1002/9781118307472.ch10>

da Costa, J.B., Rodgher, S., Daniel, L.A., Espíndola, E.L.G., 2014. Toxicity on aquatic organisms exposed to secondary effluent disinfected with chlorine, peracetic acid, ozone and UV radiation. *Ecotoxicology* 23, 1803–1813. <https://doi.org/10.1007/s10646-014-1346-z>

Daeschlein, G., von Woedtke, T., Kindel, E., Brandenburg, R., Weltmann, K.-D., Jünger, M., 2010. Antibacterial Activity of an Atmospheric Pressure Plasma Jet Against Relevant

Wound Pathogens in vitro on a Simulated Wound Environment. *Plasma Process. Polym.*

7, 224–230. <https://doi.org/10.1002/ppap.200900059>

Daş, E., Gürakan, G.C., Bayındırlı, A., 2006. Effect of controlled atmosphere storage, modified atmosphere packaging and gaseous ozone treatment on the survival of *Salmonella Enteritidis* on cherry tomatoes. *Food Microbiol.* 23, 430–438. <https://doi.org/10.1016/j.fm.2005.08.002>

Daverey, A., Pakshirajan, K., 2011. Pretreatment of synthetic dairy wastewater using the sophorolipid-producing yeast *Candida bombicola*. *Appl. Biochem. Biotechnol.* 163, 720–8. <https://doi.org/10.1007/s12010-010-9077-y>

Davin-Regli, A., Pagès, J.M., 2012. Cross-resistance between biocides and antimicrobials: an emerging question. *Rev. Sci. Tech.* 31, 89–104.

Davis, M.J., Coote, P.J., O’Byrne, C.P., 1996. Acid tolerance in *Listeria monocytogenes*: The adaptive acid tolerance response (ATR) and growth-phase-dependent acid resistance. *Microbiology.* <https://doi.org/10.1099/13500872-142-10-2975>

Davoren, M., Fogarty, A.M., 2006. In vitro cytotoxicity assessment of the biocidal agents sodium o-phenylphenol, sodium o-benzyl-p-chlorophenol, and sodium p-tertiary amylphenol using established fish cell lines. *Toxicol. Vit.* <https://doi.org/10.1016/j.tiv.2006.03.005>

Deering, A.J., Mauer, L.J., Pruitt, R.E., 2012. Internalization of *E. coli* O157:H7 and *Salmonella* spp. in plants: A review. *Food Res. Int.* 45, 567–575. <https://doi.org/10.1016/j.foodres.2011.06.058>

Degirmencioglu, N., Esmer, O.K., Irkin, R., Degirmencioglu, A., 2012. Effects of Vacuum

and Modified Atmosphere Packaging on Shelf Life Extension of Minced Meat Chemical and Microbiological Changes. *J. Anim. Vet. Adv.* 11, 898–911.

<https://doi.org/10.3923/javaa.2012.898.911>

Delaquis, P., Bach, S., 2012. Resistance and Sublethal Damage, in: *Decontamination of Fresh and Minimally Processed Produce*. Wiley-Blackwell, Oxford, UK, pp. 77–86.

<https://doi.org/10.1002/9781118229187.ch4>

Dobrynin, D., Fridman, G., Friedman, G., Fridman, A., 2009a. Physical and biological mechanisms of direct plasma interaction with living tissue. *New J. Phys.* 11, 115020.

<https://doi.org/10.1088/1367-2630/11/11/115020>

Dobrynin, D., Fridman, G., Friedman, G., Fridman, A., 2009b. Physical and biological mechanisms of direct plasma interaction with living tissue. *New J. Phys.*

<https://doi.org/10.1088/1367-2630/11/11/115020>

Dobrynin, D., Fridman, G., Friedman, G., Fridman, A., 2009c. Physical and biological mechanisms of direct plasma interaction with living tissue. *New J. Phys.* 11, 115020.

<https://doi.org/10.1088/1367-2630/11/11/115020>

Dodd, M.C., 2012. Potential impacts of disinfection processes on elimination and deactivation of antibiotic resistance genes during water and wastewater treatment. *J. Environ. Monit.* 14, 1754.

<https://doi.org/10.1039/c2em00006g>

Donaldson, J.R., Nanduri, B., Burgess, S.C., Lawrence, M.L., 2009. Comparative proteomic analysis of *Listeria monocytogenes* strains F2365 and EGD. *Appl. Environ. Microbiol.*

<https://doi.org/10.1128/AEM.01847-08>

- Drakopoulou, S., Terzakis, S., Fountoulakis, M.S., Mantzavinos, D., Manios, T., 2009. Ultrasound-induced inactivation of gram-negative and gram-positive bacteria in secondary treated municipal wastewater. *Ultrason. Sonochem.* 16, 629–634. <https://doi.org/10.1016/j.ultsonch.2008.11.011>
- Dufour, M., Simmonds, R.S., Bremer, P.J., 2004. Development of a laboratory scale clean-in-place system to test the effectiveness of “natural” antimicrobials against dairy biofilms. *J. Food Prot.* 67, 1438–43.
- Dychdala, G.R., 2001. Chlorine and Chlorine compounds, in: Block, S.S. (Ed.), *Disinfection, Sterilization, and Preservation*. Lippincott Williams & Wilkins, Philadelphia, pp. 135–157.
- EFSA, 2017. The European Union summary report on trends and sources of zoonoses, zoonotic agents and food-borne outbreaks in 2016. *EFSA J.* 15, 228. <https://doi.org/10.2903/j.efsa.2017.5077>
- EFSA, 2015a. The European Union summary report on trends and sources of zoonoses, zoonotic agents and food-borne outbreaks in 2014, *EFSA Journal*. <https://doi.org/10.2903/j.efsa.2015.4329>
- EFSA, 2015b. Risks for public health related to the presence of chlorate in food. *EFSA J.* 13, 4135. <https://doi.org/10.2903/j.efsa.2015.4135>
- El-Sayed, W.S., Ouf, S.A., Mohamed, A.-A.H., 2015. Deterioration to extinction of wastewater bacteria by non-thermal atmospheric pressure air plasma as assessed by 16S rDNA-DGGE fingerprinting. *Front. Microbiol.* 6, 1098.

<https://doi.org/10.3389/fmicb.2015.01098>

Elmehdi, H., Page, J., Scanlon, M., 2003. Using ultrasound to investigate the cellular structure of bread crumb. *J. Cereal Sci.* 38, 33–42. [https://doi.org/10.1016/S0733-5210\(03\)00002-X](https://doi.org/10.1016/S0733-5210(03)00002-X)

EPA, 2013. Environmental Protection Agency (EPA. Environ. Prot. Agency.

EPA, U.S.E.P.A., 1997. Wastewater Treatment Manuals, Primary, Secondary and Tertiary Treatment.

Ercan, U.K., Wang, H., Ji, H., Fridman, G., Brooks, A.D., Joshi, S.G., 2013. Nonequilibrium plasma-activated antimicrobial solutions are broad-spectrum and retain their efficacies for extended period of time. *Plasma Process. Polym.*  
<https://doi.org/10.1002/ppap.201200104>

Ercolini, D., Russo, F., Torrieri, E., Masi, P., Villani, F., 2006. Changes in the Spoilage-Related Microbiota of Beef during Refrigerated Storage under Different Packaging Conditions. *Appl. Environ. Microbiol.* 72, 4663–4671.  
<https://doi.org/10.1128/AEM.00468-06>

Erickson, M.C., 2012. Internalization of Fresh Produce by Foodborne Pathogens. *Annu. Rev. Food Sci. Technol.* 3, 283–310. <https://doi.org/10.1146/annurev-food-022811-101211>

Erkmen, O., 2000. Antimicrobial effects of pressurised carbon dioxide on *Brochothrix thermosphacta* in broth and foods. *J. Sci. Food Agric.* 80, 1365–1370.  
[https://doi.org/10.1002/1097-0010\(200007\)80:9<1365::AID-JSFA652>3.0.CO;2-P](https://doi.org/10.1002/1097-0010(200007)80:9<1365::AID-JSFA652>3.0.CO;2-P)



- FAO, 2013. Food Outlook: Biannual Report on Global Food Markets. Meat and Meat Products. Food and Agriculture Organization (FAO) of the United Nations (UN), Rome, Italy.
- FAOSTAT, 2013. FAO statistical database [WWW Document]. Food Agric. Organ. United Nations. URL <http://faostat3.fao.org/> (accessed 5.20.16).
- Fatemi, P., Frank, J.F., 1999. Inactivation of *Listeria monocytogenes*/Pseudomonas Biofilms by Peracid Sanitizers. J. food Prot. Prot. 761–5.
- FDA, 2016. Safe Practices for Food Processes [WWW Document]. URL <http://www.fda.gov/Food/FoodScienceResearch/SafePracticesforFoodProcesses/ucm091265.htm>
- Feehily, C., Finnerty, A., Casey, P.G., Hill, C., Gahan, C.G.M., O’Byrne, C.P., Karatzas, K.A.G., 2014. Divergent evolution of the activity and regulation of the glutamate decarboxylase systems in *Listeria monocytogenes* EGD-e and 10403S: Roles in virulence and acid tolerance. PLoS One. <https://doi.org/10.1371/journal.pone.0112649>
- Ferreira, A., O’Byrne, C.P., Boor, K.J., 2001. Role of sigma(B) in heat, ethanol, acid, and oxidative stress resistance and during carbon starvation in *Listeria monocytogenes*. Appl. Environ. Microbiol. <https://doi.org/10.1128/AEM.67.10.4454>
- Fitzgerald, D.J., Stratford, M., Gasson, M.J., Ueckert, J., Bos, A., Narbad, A., 2004. Mode of antimicrobial action of vanillin against *Escherichia coli*, *Lactobacillus plantarum* and *Listeria innocua*. J. Appl. Microbiol. 97, 104–13. <https://doi.org/10.1111/j.1365-2672.2004.02275.x>

- Forshell, L.P., Wierup, M., 2006. Salmonella contamination: a significant challenge to the global marketing of animal food products. *Rev. Sci. Tech.* 25, 541–54.
- Frank, J.F. (University of G.A.G., Koffi, R.A., 1990. Surface-adherent growth of *Listeria monocytogenes* is associated with increased resistance to surfactant sanitizers and heat. *J. food Prot.*
- Fridman, A., 2008. *Plasma chemistry*. Cambridge university press.
- Fridman, A., Chirokov, A., Gutsol, A., 2005. Non-thermal atmospheric pressure discharges, in: *Journal of Physics D: Applied Physics*. <https://doi.org/10.1088/0022-3727/38/2/R01>
- Fridman, G., Brooks, A.D., Balasubramanian, M., Fridman, A., Gutsol, A., Vasilets, V.N., Ayan, H., Friedman, G., 2007. Comparison of Direct and Indirect Effects of Non-Thermal Atmospheric-Pressure Plasma on Bacteria. *Plasma Process. Polym.* 4, 370–375. <https://doi.org/10.1002/ppap.200600217>
- Fridman, G., Friedman, G., Gutsol, A., Shekhter, A.B., Vasilets, V.N., Fridman, A., 2008. *Applied Plasma Medicine*. *Plasma Process. Polym.* 5, 503–533. <https://doi.org/10.1002/ppap.200700154>
- Friedman, M.S., Roels, T., Koehler, J.E., Feldman, L., Bibb, W.F., Blake, P., 1999. *Escherichia coli* O157:H7 outbreak associated with an improperly chlorinated swimming pool. *Clin. Infect. Dis.* 29, 298–303. <https://doi.org/10.1086/520204>
- Gahan, C.G.M., Hill, C., 2014. *Listeria monocytogenes*: survival and adaptation in the gastrointestinal tract. *Front. Cell. Infect. Microbiol.* <https://doi.org/10.3389/fcimb.2014.00009>

- Gahan, C.G.M., O'Driscoll, B., Hill, C., 1996. Acid adaptation of *Listeria monocytogenes* can enhance survival in acidic foods and during milk fermentation. *Appl. Environ. Microbiol.*
- Gallagher, M.J., Vaze, N., Gangoli, S., Vasilets, V.N., Gutsol, A.F., Milovanova, T.N., Anandan, S., Murasko, D.M., Fridman, A.A., 2007. Rapid Inactivation of Airborne Bacteria Using Atmospheric Pressure Dielectric Barrier Grating Discharge. *IEEE Trans. Plasma Sci.* 35, 1501–1510. <https://doi.org/10.1109/TPS.2007.905209>
- Galloway, W.R.J.D., Hodgkinson, J.T., Bowden, S.D., Welch, M., Spring, D.R., 2011. Quorum sensing in Gram-negative bacteria: small-molecule modulation of AHL and AI-2 quorum sensing pathways. *Chem. Rev.* 111, 28–67. <https://doi.org/10.1021/cr100109t>
- Gandhi, M., Chikindas, M.L., 2007. *Listeria*: A foodborne pathogen that knows how to survive. *Int. J. Food Microbiol.* 113, 1–15. <https://doi.org/10.1016/j.ijfoodmicro.2006.07.008>
- Gardner, G.A., 1966. A selective medium for the enumeration of *Microbacterium thermosphactum* in meat and meat products. *J. Appl. Bacteriol.* 29, 455–60.
- Garvey, M., Clifford, E., O'Reilly, E., Rowan, N.J., 2013. Efficacy of Using Harmless *Bacillus* Endospores to Estimate the Inactivation of *Cryptosporidium parvum* Oocysts in Water. *J. Parasitol.* 99, 448–452. <https://doi.org/10.1645/12-48.1>
- Gayán, E., Condón, S., Álvarez, I., 2014. Biological Aspects in Food Preservation by Ultraviolet Light: a Review. *Food Bioprocess Technol.* 7, 1–20. <https://doi.org/10.1007/s11947-013-1168-7>

- Giaouris, E., Chorianopoulos, N., Doulgeraki, A., Nychas, G.J., 2013. Co-Culture with *Listeria monocytogenes* within a Dual-Species Biofilm Community Strongly Increases Resistance of *Pseudomonas putida* to Benzalkonium Chloride. *PLoS One*.  
<https://doi.org/10.1371/journal.pone.0077276>
- Gil, M.I., Allende, A., 2018. Water and Wastewater Use in the Fresh Produce Industry: Food Safety and Environmental Implications, in: Pérez-Rodríguez, F., Skandamis, P., Valdramidis, V. (Eds.), *Quantitative Methods for Food Safety and Quality in the Vegetable Industry*. *Food Microbiology and Food Safety*. Springer, Cham, Cham, pp. 59–76. [https://doi.org/10.1007/978-3-319-68177-1\\_4](https://doi.org/10.1007/978-3-319-68177-1_4)
- Gil, M.I., Marín, A., Andujar, S., Allende, A., 2016. Should chlorate residues be of concern in fresh-cut salads? *Food Control*. <https://doi.org/10.1016/j.foodcont.2015.08.023>
- Golberg, D., Kroupitski, Y., Belausov, E., Pinto, R., Sela, S., 2011. *Salmonella* Typhimurium internalization is variable in leafy vegetables and fresh herbs. *Int. J. Food Microbiol.* 145, 250–257. <https://doi.org/10.1016/j.ijfoodmicro.2010.12.031>
- Gomes, A., Fernandes, E., Lima, J.L.F.C., 2005. Fluorescence probes used for detection of reactive oxygen species. *J. Biochem. Biophys. Methods*.  
<https://doi.org/10.1016/j.jbbm.2005.10.003>
- Gopal, K., Tripathy, S.S., Bersillon, J.L., Dubey, S.P., 2007. Chlorination byproducts, their toxicodynamics and removal from drinking water. *J. Hazard. Mater.* 140, 1–6.  
<https://doi.org/10.1016/j.jhazmat.2006.10.063>
- Gough, R.H., Samkutty, P.J., McGrew, P., Arauz, J., Adkinson, R.W., 2000. Prediction of

- effluent biochemical oxygen demand in a dairy plant SBR wastewater system\*. J. Environ. Sci. Heal. Part A 35, 169–175. <https://doi.org/10.1080/10934520009376961>
- Granger, A.C., Gaidamakova, E.K., Matrosova, V.Y., Daly, M.J., Setlow, P., 2011. Effects of Mn and Fe levels on *Bacillus subtilis* spore resistance and effects of Mn<sup>2+</sup>, other divalent cations, orthophosphate, and dipicolinic acid on protein resistance to ionizing radiation. *Appl. Environ. Microbiol.* 77, 32–40. <https://doi.org/10.1128/AEM.01965-10>
- Graves, D.B., 2012. The emerging role of reactive oxygen and nitrogen species in redox biology and some implications for plasma applications to medicine and biology. *J. Phys. D. Appl. Phys.* <https://doi.org/10.1088/0022-3727/45/26/263001>
- Gribble, A., Brightwell, G., 2013. Spoilage characteristics of *Brochothrix thermosphacta* and *campestris* in chilled vacuum packaged lamb, and their detection and identification by real time PCR. *Meat Sci.* 94, 361–368. <https://doi.org/10.1016/j.meatsci.2013.03.016>
- Gross, D.C., Cody, Y.S., 1985. Mechanisms of plant pathogenesis by *Pseudomonas* species. *Can. J. Microbiol.* 31, 403–410. <https://doi.org/10.1139/m85-076>
- Gu, G., Cevallos-Cevallos, J.M., van Bruggen, A.H.C., 2013. Ingress of *Salmonella enterica* Typhimurium into Tomato Leaves through Hydathodes. *PLoS One* 8, e53470. <https://doi.org/10.1371/journal.pone.0053470>
- Guldimann, C., Guariglia-Oropeza, V., Harrand, S., Kent, D., Boor, K.J., Wiedmann, M., 2017. Stochastic and Differential Activation of  $\sigma$ B and PrfA in *Listeria monocytogenes* at the Single Cell Level under Different Environmental Stress Conditions. *Front. Microbiol.* <https://doi.org/10.3389/fmicb.2017.00348>

- Guo, J., Huang, K., Wang, J., 2015. Bactericidal effect of various non-thermal plasma agents and the influence of experimental conditions in microbial inactivation: A review. *Food Control*. doi:10.1016/j.foodcont.2014.09.037
- Gurof, C., Ekinçi, F.Y., Aslan, N., Korachi, M., 2012. Low Temperature Plasma for decontamination of *E. coli* in milk. *Int. J. Food Microbiol.*  
<https://doi.org/10.1016/j.ijfoodmicro.2012.02.016>
- Guzel-Seydim, Z.B., Greene, A.K., Seydim, A.C., 2004. Use of ozone in the food industry 37, 453–460. <https://doi.org/10.1016/j.lwt.2003.10.014>
- Habimana, O., Heir, E., Langsrud, S., Åsli, A.W., Møretrø, T., 2010. Enhanced Surface Colonization by *Escherichia coli* O157:H7 in Biofilms Formed by an *Acinetobacter calcoaceticus* Isolate from Meat-Processing Environments. *Appl. Environ. Microbiol.* 76, 4557–4559. <https://doi.org/10.1128/AEM.02707-09>
- Hall-Stoodley, L., Costerton, J.W., Stoodley, P., 2004. Bacterial biofilms: from the Natural environment to infectious diseases. *Nat. Rev. Microbiol.* 2, 95–108.  
<https://doi.org/10.1038/nrmicro821>
- Han, L., Boehm, D., Milosavljević, V., Amias, E., Cullen, P., 2016a. Atmospheric Cold Plasma Interactions with Modified Atmosphere Packaging Inducer Gases for Safe Food Preservation. *Innov. Food Sci. Emerg. Technol.*  
<https://doi.org/10.1016/j.ifset.2016.09.026>
- Han, L., Boehm, D., Patil, S., Cullen, P.J., Bourke, P., 2016. Assessing stress responses to atmospheric cold plasma exposure using *Escherichia coli* knock-out mutants. *J. Appl.*

Microbiol. <https://doi.org/10.1111/jam.13172>

Han, L., Patil, S., Boehm, D., Milosavljević, V., Cullen, P.J., Bourke, P., 2015. Mechanisms of Inactivation by High-Voltage Atmospheric Cold Plasma Differ for *Escherichia coli* and *Staphylococcus aureus*. *Appl. Environ. Microbiol.* 82, 450–458.

<https://doi.org/10.1128/AEM.02660-15>

Han, L., Patil, S., Boehm, D., Milosavljević, V., Cullen, P.J., Bourke, P., 2015. Mechanisms of Inactivation by High-Voltage Atmospheric Cold Plasma Differ for *Escherichia coli* and *Staphylococcus aureus*. *Appl. Environ. Microbiol.* 82, 450–8.

<https://doi.org/10.1128/AEM.02660-15>

Han, L., Patil, S., Keener, K.M., Cullen, P., Bourke, P., 2014. Bacterial Inactivation by High Voltage Atmospheric Cold Plasma: Influence of Process Parameters and Effects on Cell Leakage and DNA. *J. Appl. Microbiol.* <https://doi.org/10.1111/jam.12426>

Han, L., Patil, S., Keener, K.M., Cullen, P.J., Bourke, P., 2014. Bacterial inactivation by high-voltage atmospheric cold plasma: influence of process parameters and effects on cell leakage and DNA. *J. Appl. Microbiol.* 116, 784–794.

<https://doi.org/10.1111/jam.12426>

Han, L., Ziuzina, D., Heslin, C., Boehm, D., Patange, A., Sango, D.M., Valdramidis, V.P., Cullen, P.J., Bourke, P., 2016b. Controlling microbial safety challenges of meat using high voltage atmospheric cold plasma. *Front. Microbiol.*

<https://doi.org/10.3389/fmicb.2016.00977>

Han, L., Ziuzina, D., Heslin, C., Boehm, D., Patange, A., Sango, D.M., Valdramidis, V.P.,

- Cullen, P.J., Bourke, P., 2016c. Controlling Microbial Safety Challenges of Meat Using High Voltage Atmospheric Cold Plasma. *Front. Microbiol.* 7, 977.  
<https://doi.org/10.3389/fmicb.2016.00977>
- Hayes, J., Kirf, D., Garvey, M., Rowan, N., 2013. Disinfection and toxicological assessments of pulsed UV and pulsed-plasma gas-discharge treated-water containing the waterborne protozoan enteroparasite *Cryptosporidium parvum*. *J. Microbiol. Methods* 94, 325–337.  
<https://doi.org/10.1016/j.mimet.2013.07.012>
- Henriques, A.O., Charles P. Moran, J., 2007. Structure, Assembly, and Function of the Spore Surface Layers. <http://dx.doi.org/10.1146/annurev.micro.61.080706.093224>.
- Hernández-Sancho, F., Lamizana-Diallo, B., Mateo-Sagasta, M., Qadir, M., 2015. Economic Valuation of Wastewater the Cost of Action and the Cost of No Action. Unep.  
<https://doi.org/ISBN:978-92-807-3474-4>
- Hill, C., Cotter, P.D., Sleator, R.D., Gahan, C.G.M., 2002. Bacterial stress response in *Listeria monocytogenes*: Jumping the hurdles imposed by minimal processing, in: *International Dairy Journal*. [https://doi.org/10.1016/S0958-6946\(01\)00125-X](https://doi.org/10.1016/S0958-6946(01)00125-X)
- Holko, I., Bisova, T., Holkova, Z., Kmet, V., 2006. Virulence markers of *Escherichia coli* strains isolated from traditional cheeses made from unpasteurised sheep milk in Slovakia. *Food Control* 17, 393–396. <https://doi.org/10.1016/j.foodcont.2005.01.007>
- Holvoet, K., Jacxsens, L., Sampers, I., Uyttendaele, M., 2012. Insight into the prevalence and distribution of microbial contamination to evaluate water management in the fresh produce processing industry. *J. Food Prot.* 75, 671–81. <https://doi.org/10.4315/0362->



HPA, 2009. Ready-to-eat foods: microbiological safety assessment guidelines - GOV.UK [WWW Document]. URL <https://www.gov.uk/government/publications/ready-to-eat-foods-microbiological-safety-assessment-guidelines> (accessed 10.6.16).

Hu, Y., Zhu, W., Liu, K., Han, L., Zheng, Z., Hu, H., 2018. Influence of water content on the inactivation of *P. digitatum* spores using an air–water plasma jet. *Plasma Sci. Technol.* 20, 044011. <https://doi.org/10.1088/2058-6272/aaa8da>

Ikawa, S., Kitano, K., Hamaguchi, S., 2010. Effects of pH on bacterial inactivation in aqueous solutions due to low-temperature atmospheric pressure plasma application. *Plasma Process. Polym.* <https://doi.org/10.1002/ppap.200900090>

Imlay, J.A., 2013. The molecular mechanisms and physiological consequences of oxidative stress: Lessons from a model bacterium. *Nat. Rev. Microbiol.* <https://doi.org/10.1038/nrmicro3032>

Jahid, I.K., Han, N., Zhang, C.-Y., Ha, S.-D., 2015. Mixed culture biofilms of *Salmonella* Typhimurium and cultivable indigenous microorganisms on lettuce show enhanced resistance of their sessile cells to cold oxygen plasma. *Food Microbiol.* 46, 383–394. <https://doi.org/10.1016/j.fm.2014.08.003>

Janex, M., Savoye, P., Roustan, M., Do-Quang, Z., Laine, J.M., Lazarova, V., 2000. *Wastewater Disinfection by Ozone: Influence of Water Quality and Kinetics Modeling.* <http://dx.doi.org/10.1080/01919510008547215>.

Jayasena, D.D., Kim, H.J., Yong, H.I., Park, S., Kim, K., Choe, W., Jo, C., 2015. Flexible

thin-layer dielectric barrier discharge plasma treatment of pork butt and beef loin:

Effects on pathogen inactivation and meat-quality attributes. *Food Microbiol.*

<https://doi.org/10.1016/j.fm.2014.07.009>

Jing, Z., Cao, S., 2012. Combined application of UV photolysis and ozonation with biological aerating filter in tertiary wastewater treatment. *Int. J. Photoenergy.*

doi:10.1155/2012/140605

Johnson, E., 2002. Microbial Adaptation and Survival in Foods, in: *Microbial Stress*

*Adaptation and Food Safety.* CRC Press. <https://doi.org/10.1201/9781420012828.ch4>

Joseph, B., Otta, S.K., Karunasagar, I., Karunasagar, I., 2001. Biofilm formation by

*Salmonella* spp. on food contact surfaces and their sensitivity to sanitizers. *Int. J. Food Microbiol.* 64, 367–372.

Joshi, S., Cooper, M., Yost, A., Paff, M., Ercan, U.K., Fridman, G., Friedman, G., Fridman,

A., Brooks, A.D., 2011. Nonthermal dielectric-barrier discharge plasma-induced inactivation involves oxidative DNA damage and membrane lipid peroxidation in

*Escherichia coli*. *Antimicrob. Agents Chemother.* [https://doi.org/10.1128/AAC.01002-](https://doi.org/10.1128/AAC.01002-10)

10

Joshi, S.G., Cooper, M., Yost, A., Paff, M., Ercan, U.K., Fridman, G., Friedman, G.,

Fridman, A., Brooks, A.D., 2011. Nonthermal dielectric-barrier discharge plasma-induced inactivation involves oxidative DNA damage and membrane lipid peroxidation

in *Escherichia coli*. *Antimicrob. Agents Chemother.* 55, 1053–62.

<https://doi.org/10.1128/AAC.01002-10>

Julák, J., Scholtz, V., Kotúčová, S., Janoušková, O., 2012a. The persistent microbicidal effect in water exposed to the corona discharge. *Phys. Medica*.

<https://doi.org/10.1016/j.ejmp.2011.08.001>

Julák, J., Scholtz, V., Kotúčová, S., Janoušková, O., 2012b. The persistent microbicidal effect in water exposed to the corona discharge. *Phys. Med.* 28, 230–9.

<https://doi.org/10.1016/j.ejmp.2011.08.001>

Kazmierczak, M.J., Mithoe, S.C., Boor, K.J., Wiedmann, M., 2003. *Listeria monocytogenes*  $\sigma^B$  regulates stress response and virulence functions. *J. Bacteriol.*

<https://doi.org/10.1128/JB.185.19.5722-5734.2003>

Kazmierczak, M.J., Wiedmann, M., Boor, K.J., 2005. Alternative Sigma Factors and Their Roles in Bacterial Virulence. *Microbiol. Mol. Biol. Rev.*

<https://doi.org/10.1128/MMBR.69.4.527-543.2005>

Kelly-Wintenberg, K., Hodge, A., Montie, T.C., Deleanu, L., Sherman, D., Reece Roth, J., Tsai, P., Wadsworth, L., 1999. Use of a one atmosphere uniform glow discharge plasma to kill a broad spectrum of microorganisms. *J. Vac. Sci. Technol. A Vacuum, Surfaces, Film.* 17, 1539. <https://doi.org/10.1116/1.581849>

Khadre, M.A., Yousef, A.E., Kim, J.-G., 2001. Microbiological Aspects of Ozone Applications in Food: A Review. *J. Food Sci.* 66, 1242–1252.

<https://doi.org/10.1111/j.1365-2621.2001.tb15196.x>

Kiefer, J., 2007. Effects of Ultraviolet Radiation on DNA, in: *Chromosomal Alterations*.

Springer Berlin Heidelberg, Berlin, Heidelberg, pp. 39–53. <https://doi.org/10.1007/978->

- Kim, B., Yun, H., Jung, S., Jung, Y., Jung, H., Choe, W., Jo, C., 2011. Effect of atmospheric pressure plasma on inactivation of pathogens inoculated onto bacon using two different gas compositions. *Food Microbiol.* 28, 9–13. <https://doi.org/10.1016/j.fm.2010.07.022>
- Kim, J.-G., Yousef, A.E., Chism, G.W., 1999. Use of Ozone to Inactivate Microorganisms on Lettuce. *J. Food Saf.* <https://doi.org/10.1111/j.1745-4565.1999.tb00231.x>
- Kim, J.E., Lee, D.-U., Min, S.C., 2014. Microbial decontamination of red pepper powder by cold plasma. *Food Microbiol.* 38, 128–36. <https://doi.org/10.1016/j.fm.2013.08.019>
- Kim, J.G., Yousef, A.E., Dave, S., 1999. Application of ozone for enhancing the microbiological safety and quality of foods: a review. *J. Food Prot.* 62, 1071–87.
- Kim, S.-H., Wei, C.-I., 2012. Biofilms, in: *Decontamination of Fresh and Minimally Processed Produce*. Wiley-Blackwell, Oxford, UK, pp. 59–75.  
<https://doi.org/10.1002/9781118229187.ch3>
- Kirby, R.M., Bartram, J., Carr, R., 2003. Water in food production and processing: Quantity and quality concerns. *Food Control.* [https://doi.org/10.1016/S0956-7135\(02\)00090-7](https://doi.org/10.1016/S0956-7135(02)00090-7)
- Kobyas, M., Senturk, E., Bayramoglu, M., 2006. Treatment of poultry slaughterhouse wastewaters by electrocoagulation. *J. Hazard. Mater.* 133, 172–176.  
<https://doi.org/10.1016/j.jhazmat.2005.10.007>
- Kogelschatz, U., 2004. Atmospheric-pressure plasma technology. *Plasma Phys. Control. Fusion* 46, B63–B75. <https://doi.org/10.1088/0741-3335/46/12B/006>

- Kogelschatz, U., 2003. Dielectric-barrier Discharges: Their History, Discharge Physics, and Industrial Applications. *Plasma Chem. Plasma Process.* 23.
- Kogelschatz, U., 2002. Filamentary, patterned, and diffuse barrier discharges. *IEEE Trans. Plasma Sci.* 30, 1400–1408. <https://doi.org/10.1109/TPS.2002.804201>
- Kohanski, M.A., Dwyer, D.J., Hayete, B., Lawrence, C.A., Collins, J.J., 2007. A Common Mechanism of Cellular Death Induced by Bactericidal Antibiotics. *Cell.* <https://doi.org/10.1016/j.cell.2007.06.049>
- Kostaki, M., Chorianopoulos, N., Braxou, E., Nychas, G.J., Giaouris, E., 2012. Differential biofilm formation and chemical disinfection resistance of sessile cells of *Listeria monocytogenes* strains under monospecies and dual-species (with *Salmonella enterica*) conditions. *Appl. Environ. Microbiol.* <https://doi.org/10.1128/AEM.07099-11>
- Koutsoumanis, K.P., Kendall, P.A., Sofos, J.N., 2003. Effect of Food Processing-Related Stresses on Acid Tolerance of *Listeria monocytogenes*. *Appl. Environ. Microbiol.* <https://doi.org/10.1128/AEM.69.12.7514-7516.2003>
- Koutsoumanis, K.P., Stamatiou, A.P., Drosinos, E.H., Nychas, G.-J.E., 2008. Control of spoilage microorganisms in minced pork by a self-developed modified atmosphere induced by the respiratory activity of meat microflora. *Food Microbiol.* 25, 915–21. <https://doi.org/10.1016/j.fm.2008.05.006>
- Kroupitski, Y., Golberg, D., Belausov, E., Pinto, R., Swartzberg, D., Granot, D., Sela, S., 2009. Internalization of *Salmonella enterica* in Leaves Is Induced by Light and Involves Chemotaxis and Penetration through Open Stomata. *Appl. Environ. Microbiol.* 75,

6076–6086. <https://doi.org/10.1128/AEM.01084-09>

Kroupitski, Y., Golberg, D., Belausov, E., Pinto, R., Swartzberg, D., Granot, D., Sela, S., 2009. Internalization of *Salmonella enterica* in leaves is induced by light and involves chemotaxis and penetration through open stomata. *Appl. Environ. Microbiol.* <https://doi.org/10.1128/AEM.01084-09>

Langsrud, S., Moen, B., Møretrø, T., Løype, M., Heir, E., 2016. Microbial dynamics in mixed culture biofilms of bacteria surviving sanitation of conveyor belts in salmon-processing plants. *J. Appl. Microbiol.* <https://doi.org/10.1111/jam.13013>

Lee, H.J., Jung, S.M., Jung, H., Park, S., Choe, W.H., Ham, J., Jo, C., 2012. Evaluation of a Dielectric Barrier Discharge Plasma System for Inactivating Pathogens on Cheese Slices. *J. Anim. Sci. Technol.* 54, 191–198. <https://doi.org/10.5187/JAST.2012.54.3.191>

Lee, K., Paek, K., Ju, W.-T., Lee, Y., 2006. Sterilization of bacteria, yeast, and bacterial endospores by atmospheric-pressure cold plasma using helium and oxygen. *J. Microbiol.* 44, 269–75.

Leedom, J.M., 2006. Milk of nonhuman origin and infectious diseases in humans. *Clin. Infect. Dis.* 43, 610–5. <https://doi.org/10.1086/507035>

Lemon, K.P., Freitag, N.E., Kolter, R., 2010. The virulence regulator PrfA promotes biofilm formation by *Listeria monocytogenes*. *J. Bacteriol.* <https://doi.org/10.1128/JB.00179-10>

Liao, X., Liu, D., Xiang, Q., Ahn, J., Chen, S., Ye, X., Ding, T., 2017. Inactivation mechanisms of non-thermal plasma on microbes: A review. *Food Control.* <https://doi.org/10.1016/j.foodcont.2016.12.021>

- Limbo, S., Torri, L., Sinelli, N., Franzetti, L., Casiraghi, E., 2010. Evaluation and predictive modeling of shelf life of minced beef stored in high-oxygen modified atmosphere packaging at different temperatures. *Meat Sci.* 84, 129–136.  
<https://doi.org/10.1016/j.meatsci.2009.08.035>
- Lindsay, D., von Holy, A., 2006. Bacterial biofilms within the clinical setting: what healthcare professionals should know. *J. Hosp. Infect.* 64, 313–25.  
<https://doi.org/10.1016/j.jhin.2006.06.028>
- Ling, L., Jiangang, L., Minchong, S., Chunlei, Z., Yuanhua, D., 2015. Cold plasma treatment enhances oilseed rape seed germination under drought stress. *Sci. Rep.* 5, 13033.  
<https://doi.org/10.1038/srep13033>
- Lis, K.A., Boulaaba, A., Binder, S., Li, Y., Kehrenberg, C., Zimmermann, J., Klein, G., Ahlfeld, B., 2018. Inactivation of *Salmonella* Typhimurium and *Listeria monocytogenes* on ham with nonthermal atmospheric pressure plasma. *PLoS One* 13, 0197773.  
<https://doi.org/https://doi.org/10.1371/journal.pone.0197773>
- Liu, N.T., Lefcourt, A.M., Nou, X., Shelton, D.R., Zhang, G., Lo, Y.M., 2013. Native Microflora in Fresh-Cut Produce Processing Plants and Their Potentials for Biofilm Formation. *J. Food Prot.* 76, 827–832. <https://doi.org/10.4315/0362-028X.JFP-12-433>
- Liu, N.T., Nou, X., Lefcourt, A.M., Shelton, D.R., Lo, Y.M., 2014. Dual-species biofilm formation by *Escherichia coli* O157:H7 and environmental bacteria isolated from fresh-cut processing facilities. *Int. J. Food Microbiol.* 171, 15–20.  
<https://doi.org/10.1016/j.ijfoodmicro.2013.11.007>

- Liu, X., Hong, F., Guo, Y., Zhang, J., Shi, J., 2013. Sterilization of *Staphylococcus Aureus* by an Atmospheric Non-Thermal Plasma Jet. *Plasma Sci. Technol.* 15, 439–442.  
<https://doi.org/10.1088/1009-0630/15/5/09>
- Liu, Y.J., Xie, J., Zhao, L.J., Qian, Y.F., Zhao, Y., Liu, X., 2015. Biofilm Formation Characteristics of *Pseudomonas lundensis* Isolated from Meat. *J. Food Sci.*  
<https://doi.org/10.1111/1750-3841.13142>
- Locke, B.R., Sato, M., Sunka, P., Hoffmann, M.R., Chang, J.-S., 2005. Electrohydraulic Discharge and Nonthermal Plasma for Water Treatment.
- Locke, B.R., Lukes, P., Brisset, J.-L., 2012. Elementary Chemical and Physical Phenomena in Electrical Discharge Plasma in Gas-Liquid Environments and in Liquids, in: *Plasma Chemistry and Catalysis in Gases and Liquids*. Wiley-VCH Verlag GmbH & Co. KGaA, Weinheim, Germany, pp. 185–241. <https://doi.org/10.1002/9783527649525.ch6>
- Lohse, M.B., Gulati, M., Johnson, A.D., Nobile, C.J., 2017. Development and regulation of single- and multi-species *Candida albicans* biofilms. *Nat. Rev. Microbiol.* 16, 19–31.  
<https://doi.org/10.1038/nrmicro.2017.107>
- López-Gómez, A., Soto-Jover, S., Ros-Chumillas, M., 2018. New technology for enhancement of the food safety of minimally processed fruits and vegetables, in: *Acta Horticulturae*. International Society for Horticultural Science (ISHS), Leuven, Belgium, pp. 545–552. doi:10.17660/ActaHortic.2018.1194.79
- Lou, Y., Yousef, A.E., 1997. Adaptation to sublethal environmental stresses protects *Listeria monocytogenes* against lethal preservation factors. *Appl. Environ. Microbiol.*



- Lu, P., Boehm, D., Bourke, P., Cullen, P.J., 2017. Achieving reactive species specificity within plasma-activated water through selective generation using air spark and glow discharges. *Plasma Process. Polym.* e1600207. <https://doi.org/10.1002/ppap.201600207>
- Lu, P., Ziuzina, D., Cullen, P.J., Bourke, P., 2018. Inner surface biofilm inactivation by atmospheric pressure helium porous plasma jet. *Plasma Process. Polym.* 15, 1800055. <https://doi.org/10.1002/ppap.201800055>
- Lucas, M.S., Peres, J.A., Li Puma, G., 2010. Treatment of winery wastewater by ozone-based advanced oxidation processes (O<sub>3</sub>, O<sub>3</sub>/UV and O<sub>3</sub>/UV/H<sub>2</sub>O<sub>2</sub>) in a pilot-scale bubble column reactor and process economics. *Sep. Purif. Technol.* 72, 235–241. <https://doi.org/10.1016/j.seppur.2010.01.016>
- Lukes, P., Dolezalova, E., Sisrova, I., Clupek, M., 2014. Aqueous-phase chemistry and bactericidal effects from an air discharge plasma in contact with water: Evidence for the formation of peroxyxynitrite through a pseudo-second-order post-discharge reaction of H<sub>2</sub>O<sub>2</sub> and HNO<sub>2</sub>. *Plasma Sources Sci. Technol.* <https://doi.org/10.1088/0963-0252/23/1/015019>
- Lungu, B., Saldivar, J.C., Story, R., Ricke, S.C., Johnson, M.G., 2010. The combination of energy-dependent internal adaptation mechanisms and external factors enables *Listeria monocytogenes* to express a strong starvation survival response during multiple-nutrient starvation. *Foodborne Pathog. Dis.* <https://doi.org/10.1089/fpd.2009.0408>
- Luo, Q., Shang, J., Feng, X., Guo, X., Zhang, L., Zhou, Q., 2013. PrfA led to reduced biofilm formation and contributed to altered gene expression patterns in biofilm-forming *Listeria*

monocytogenes. *Curr. Microbiol.* <https://doi.org/10.1007/s00284-013-0377-7>

Ma, R., Wang, G., Tian, Y., Wang, K., Zhang, J., Fang, J., 2015. Non-thermal plasma-activated water inactivation of food-borne pathogen on fresh produce. *J. Hazard. Mater.* <https://doi.org/10.1016/j.jhazmat.2015.07.061>

Mai-Prochnow, A., Clauson, M., Hong, J., Murphy, A.B., 2016. Gram positive and Gram negative bacteria differ in their sensitivity to cold plasma. *Sci. Rep.* <https://doi.org/10.1038/srep38610>

Markland, S.M., Farkas, D.F., Kniel, K.E., Hoover, D.G., 2013. Pathogenic psychrotolerant sporeformers: an emerging challenge for low-temperature storage of minimally processed foods. *Foodborne Pathog. Dis.* 10, 413–9. <https://doi.org/10.1089/fpd.2012.1355>

Martínez-Hernández, G.B., Navarro-Rico, J., Gómez, P.A., Otón, M., Artés, F., Artés-Hernández, F., 2015. Combined sustainable sanitising treatments to reduce *Escherichia coli* and *Salmonella Enteritidis* growth on fresh-cut kailan-hybrid broccoli. *Food Control.* <https://doi.org/10.1016/j.foodcont.2014.07.029>

Martínez, S.B., Pérez-Parra, J., Suay, R., 2011. Use of Ozone in Wastewater Treatment to Produce Water Suitable for Irrigation. *Water Resour. Manag.* <https://doi.org/10.1007/s11269-011-9798-x>

Marui, T., 2013. An Introduction to Micro / ano-Bubbles and their Applications. *An Introd. to Micro / ano-Bubbles their Appl.*

McClements, D.J., 1997. Ultrasonic characterization of foods and drinks: principles,

methods, and applications. *Crit. Rev. Food Sci. Nutr.* 37, 1–46.

<https://doi.org/10.1080/10408399709527766>

McClements, D.J., 1995. Advances in the application of ultrasound in food analysis and processing. *Trends Food Sci. Technol.* 6, 293–299. [https://doi.org/10.1016/S0924-2244\(00\)89139-6](https://doi.org/10.1016/S0924-2244(00)89139-6)

McClure, P., 2005. *Escherichia coli: virulence, stress response and resistance*, in: *Understanding Pathogen Behaviour : Virulence, Stress Response and Resistance*. Woodhead, pp. 240–243.

McCollum, J.T., Cronquist, A.B., Silk, B.J., Jackson, K.A., O'Connor, K.A., Cosgrove, S., Gossack, J.P., Parachini, S.S., Jain, N.S., Etestad, P., Ibraheem, M., Cantu, V., Joshi, M., DuVernoy, T., Fogg, N.W., Gorny, J.R., Mogen, K.M., Spires, C., Teitell, P., Joseph, L.A., Tarr, C.L., Imanishi, M., Neil, K.P., Tauxe, R. V., Mahon, B.E., 2013. Multistate Outbreak of Listeriosis Associated with Cantaloupe. *N. Engl. J. Med.* <https://doi.org/10.1056/NEJMoa1215837>

McGarvey, J.A., Miller, W.G., Sanchez, S., Stanker, L., 2004. Identification of bacterial populations in dairy wastewaters by use of 16S rRNA gene sequences and other genetic markers. *Appl. Environ. Microbiol.* <https://doi.org/10.1128/AEM.70.7.4267-4275.2004>

McLean, R.A., Sulzbacher, W.L., 1953. *Microbacterium thermosphactum*, spec: nov.; a nonheat resistant bacterium from fresh pork sausage. *J. Bacteriol.* 65, 428–33.

Mecha, A.C., Onyango, M.S., Ochieng, A., Momba, M.N.B., 2016. Impact of ozonation in removing organic micro-pollutants in primary and secondary municipal wastewater:

effect of process parameters. *Water Sci. Technol.* 74, 756–765.

<https://doi.org/10.2166/wst.2016.276>

Medina-Martínez, M.S., Santana, M.A., 2012. Quorum Sensing, in: *Decontamination of Fresh and Minimally Processed Produce*. Wiley-Blackwell, Oxford, UK, pp. 333–344.

<https://doi.org/10.1002/9781118229187.ch19>

Melo, R., Cabo Verde, S., Branco, J., Botelho, M.L., 2008. Gamma radiation induced effects on slaughterhouse wastewater treatment, *Radiation Physics and Chemistry*.

<https://doi.org/10.1016/j.radphyschem.2007.03.006>

Misra, N.N., Han, L., Tiwari, B.K., Bourke, P., Cullen, P.J., 2014. Nonthermal plasma technology for decontamination of foods. *Nov. Food Preserv. Microb. Assess. Tech.* 155.

Misra, N.N., Tiwari, B.K., Raghavarao, K.S.M.S., Cullen, P.J., 2011. Nonthermal Plasma Inactivation of Food-Borne Pathogens. *Food Eng. Rev.* 3, 159–170.

<https://doi.org/10.1007/s12393-011-9041-9>

Moncada, M., J. Aryana, K., Boeneke, C., 2012. Effect of Mild Sonication Conditions on the Attributes of *Lactobacillus delbrueckii* ssp. *bulgaricus* LB-12. *Adv. Microbiol.* 02, 104–111. <https://doi.org/10.4236/aim.2012.22014>

Monnet, V., Gardan, R., 2015. Quorum-sensing regulators in Gram-positive bacteria: “cherchez le peptide”. *Mol. Microbiol.* 97, 181–4. <https://doi.org/10.1111/mmi.13060>

Monsen, T., Lovgren, E., Widerstrom, M., Wallinder, L., 2009. In Vitro Effect of Ultrasound on Bacteria and Suggested Protocol for Sonication and Diagnosis of Prosthetic

- Infections. *J. Clin. Microbiol.* 47, 2496–2501. <https://doi.org/10.1128/JCM.02316-08>
- Montville, J.T., Matthews, R.K., 2008. *Food Microbiology: An Introduction*, Second. ed. ASM press.
- Morent, R., De, N., 2011. Inactivation of Bacteria by Non-Thermal Plasmas, in: *Biomedical Engineering - Frontiers and Challenges*. InTech. <https://doi.org/10.5772/18610>
- Møretrø, T., Langsrud, S., 2017. Residential Bacteria on Surfaces in the Food Industry and Their Implications for Food Safety and Quality. *Compr. Rev. Food Sci. Food Saf.* <https://doi.org/10.1111/1541-4337.12283>
- Mukherjee, A., Speh, D., Jones, A.T., Buesing, K.M., Diez-Gonzalez, F., 2006. Longitudinal Microbiological Survey of Fresh Produce Grown by Farmers in the Upper Midwest. *J. Food Prot.* 1928–1936.
- Mukhopadhyay, S., Ukuku, D.O., Juneja, V., Fan, X., 2014. Effects of UV-C treatment on inactivation of *Salmonella enterica* and *Escherichia coli* O157:H7 on grape tomato surface and stem scars, microbial loads, and quality. *Food Control* 44, 110–117. <https://doi.org/10.1016/j.foodcont.2014.03.027>
- NicAogáin, K., O’Byrne, C.P., 2016. The role of stress and stress adaptations in determining the fate of the bacterial pathogen *Listeria monocytogenes* in the food chain. *Front. Microbiol.* <https://doi.org/10.3389/fmicb.2016.01865>
- Nieminski, E.C., Bellamy, W.D., Moss, L.R., 2000. Using Surrogates to Improve Plant Performance (PDF). *J. Am. Water Works Assoc.* 92, 67–78.

- Niemira, B.A., 2012. Cold plasma decontamination of foods. *Annu. Rev. Food Sci. Technol.* 3, 125–42. <https://doi.org/10.1146/annurev-food-022811-101132>
- Niemira, B.A., Boyd, G., Sites, J., 2014. Cold Plasma Rapid Decontamination of Food Contact Surfaces Contaminated with *Salmonella* Biofilms. *J. Food Sci.* 79, M917–M922. <https://doi.org/10.1111/1750-3841.12379>
- Niquet, R., Boehm, D., Schnabel, U., Cullen, P., Bourke, P., Ehlbeck, J., 2018. Characterising the impact of post-treatment storage on chemistry and antimicrobial properties of plasma treated water derived from microwave and DBD sources. *Plasma Process. Polym.* <https://doi.org/10.1002/ppap.201700127>
- Noriega, E., Shama, G., Laca, A., Díaz, M., Kong, M.G., 2011a. Cold atmospheric gas plasma disinfection of chicken meat and chicken skin contaminated with *Listeria innocua*. *Cold Atmospheric Gas Plasma Disinfection of Chicken Meat and Chicken Skin. Food Microbiol.* 28, 1293–1300.
- Noriega, E., Shama, G., Laca, A., Díaz, M., Kong, M.G., 2011b. Cold atmospheric gas plasma disinfection of chicken meat and chicken skin contaminated with *Listeria innocua*. *Food Microbiol.* <https://doi.org/10.1016/j.fm.2011.05.007>
- Norwood, D.E., Gilmour, A., 2000. The growth and resistance to sodium hypochlorite of *Listeria monocytogenes* in a steady-state multispecies biofilm. *J. Appl. Microbiol.* 88, 512–520. <https://doi.org/10.1046/j.1365-2672.2000.00990.x>
- Nowak, A., Rygala, A., Oltuszek-Walczak, E., Walczak, P., 2012. The prevalence and some metabolic traits of *Brochothrix thermosphacta* in meat and meat products packaged in

- different ways. *J. Sci. Food Agric.* 92, 1304–1310. <https://doi.org/10.1002/jsfa.4701>
- Nüesch-Inderbilen, M., Stephan, R., 2016. Fresh fruit and vegetables as vehicles of bacterial foodborne disease: a review and analysis of outbreaks registered by proMED-mail associated with fresh produce. *Arch. Lebensmittelhyg.* <https://doi.org/10.2376/0003-925X-67-32>
- Nychas, G.J.E., Skandamis, P.N., Tassou, C.C., Koutsoumanis, K.P., 2008. Meat spoilage during distribution. *Meat Sci.* 78, 77–89. <https://doi.org/10.1016/j.meatsci.2007.06.020>
- O’Byrne, C.P., Karatzas, K.A.G., 2008. Chapter 5 The Role of Sigma B ( $\sigma$ B) in the Stress Adaptations of *Listeria monocytogenes*: Overlaps Between Stress Adaptation and Virulence. *Adv. Appl. Microbiol.* [https://doi.org/10.1016/S0065-2164\(08\)00605-9](https://doi.org/10.1016/S0065-2164(08)00605-9)
- O’Donoghue, B., NicAogáin, K., Bennett, C., Conneely, A., Tiensuu, T., Johansson, J., O’Byrne, C., 2016. Blue-light inhibition of *Listeria monocytogenes* growth is mediated by reactive oxygen species and is influenced by  $\sigma$ B and the blue-light sensor Lmo0799. *Appl. Environ. Microbiol.* <https://doi.org/10.1128/AEM.00685-16>
- Oehmigen, K., Hähnel, M., Brandenburg, R., Wilke, C., Weltmann, K.D., Von Woedtke, T., 2010. The role of acidification for antimicrobial activity of atmospheric pressure plasma in liquids. *Plasma Process. Polym.* <https://doi.org/10.1002/ppap.200900077>
- Olaimat, A.N., Holley, R.A., 2012. Factors influencing the microbial safety of fresh produce: A review. *Food Microbiol.* <https://doi.org/10.1016/j.fm.2012.04.016>
- Oliveira, M., Viñas, I., Colàs, P., Anguera, M., Usall, J., Abadias, M., 2014. Effectiveness of a bacteriophage in reducing *Listeria monocytogenes* on fresh-cut fruits and fruit juices.

Food Microbiol. <https://doi.org/10.1016/j.fm.2013.08.018>

Oliver, J.D., 2010. Recent findings on the viable but nonculturable state in pathogenic bacteria. *FEMS Microbiol. Rev.* 34, 415–25. <https://doi.org/10.1111/j.1574-6976.2009.00200.x>

Oliver, S.P., Jayarao, B.M., Almeida, R.A., 2005. Foodborne Pathogens in Milk and the Dairy Farm Environment: Food Safety and Public Health Implications. *Foodborne Pathog. Dis.* <https://doi.org/10.1089/fpd.2005.2.115>

Ölmez, H., Temur, S.D., 2010. Effects of different sanitizing treatments on biofilms and attachment of *Escherichia coli* and *Listeria monocytogenes* on green leaf lettuce. *LWT - Food Sci. Technol.* 43, 964–970. <https://doi.org/10.1016/j.lwt.2010.02.005>

Olsen, S.J., MacKinnon, L.C., Goulding, J.S., Bean, N.H., Slutsker, L., 2000. Surveillance for foodborne-disease outbreaks--United States, 1993-1997. *MMWR. CDC Surveill. Summ.* 49, 1–62.

Orsi, R.H., Wiedmann, M., 2016. Characteristics and distribution of *Listeria* spp., including *Listeria* species newly described since 2009. *Appl. Microbiol. Biotechnol.* <https://doi.org/10.1007/s00253-016-7552-2>

Osés, S.M., Diez, A.M., Melero, B., Luning, P.A., Jaime, I., Rovira, J., 2013. Characterization by culture-dependent and culture-independent methods of the bacterial population of suckling-lamb packaged in different atmospheres. *Food Microbiol.* 36, 216–222. <https://doi.org/10.1016/j.fm.2013.05.005>

Ozyonar, F., Karagozoglou, B., 2014. Investigation of technical and economic analysis of



- electrocoagulation process for the treatment of great and small cattle slaughterhouse wastewater. <http://dx.doi.org/10.1080/19443994.2013.787373>.
- Pan, Y., Breidt, F., Kathariou, S., 2009. Competition of *Listeria monocytogenes* serotype 1/2a and 4b strains in mixed-culture biofilms. *Appl. Environ. Microbiol.* <https://doi.org/10.1128/AEM.00816-09>
- Pang, X., Yang, Y., Yuk, H.G., 2017. Biofilm formation and disinfectant resistance of *Salmonella* spp. in mono- and dual-species with *Pseudomonas aeruginosa*. *J Appl Microbiol* 123, 651–660. <https://doi.org/10.1111/jam.13521>
- Pankaj, S.K., Misra, N.N., Cullen, P.J., 2013. Kinetics of Tomato Peroxidase Inactivation by Atmospheric Pressure Cold Plasma Based on Dielectric Barrier Discharge. *Innov. Food Sci. Emerg. Technol.* 19, 153–157.
- Papaoiannou, E., Giaouris, E.D., Berillis, P., Boziaris, I.S., 2018. Dynamics of biofilm formation by *Listeria monocytogenes* on stainless steel under mono-species and mixed-culture simulated fish processing conditions and chemical disinfection challenges. *Int. J. Food Microbiol.* <https://doi.org/10.1016/j.ijfoodmicro.2017.12.020>
- Parijs, I., Steenackers, H.P., 2018. Competitive inter-species interactions underlie the increased antimicrobial tolerance in multispecies brewery biofilms. *ISME J.* <https://doi.org/10.1038/s41396-018-0146-5>
- Parkar, S., Flint, S., Teh, K.H., Brooks, J., Bremer, P., 2015. Pathogen contamination in dairy manufacturing environments, in: *Biofilms in the Dairy Industry*. <https://doi.org/10.1002/9781118876282.ch9>

- Patange, A., Boehm, D., Giltrap, M., Lu, P., Cullen, P.J., Bourke, P., 2018. Assessment of the disinfection capacity and eco-toxicological impact of atmospheric cold plasma for treatment of food industry effluents. *Sci. Total Environ.* 631–632.  
<https://doi.org/10.1016/j.scitotenv.2018.02.269>
- Patel, J., Sharma, M., 2010. Differences in attachment of *Salmonella enterica* serovars to cabbage and lettuce leaves. *Int. J. Food Microbiol.* 139, 41–47.  
<https://doi.org/10.1016/j.ijfoodmicro.2010.02.005>
- Patel, R., 2005. Biofilms and antimicrobial resistance. *Clin. Orthop. Relat. Res.* 41–7.
- Patil, S., Bourke, P., Frias, J.M., Tiwari, B.K., Cullen, P.J., 2009. Inactivation of *Escherichia coli* in orange juice using ozone. *Innov. Food Sci. Emerg. Technol.* 10, 551–557.  
<https://doi.org/10.1016/j.ifset.2009.05.011>
- Patil, S., Bourke, P., Kelly, B., Frías, J.M., Cullen, P.J., 2009. The effects of acid adaptation on *Escherichia coli* inactivation using power ultrasound. *Innov. Food Sci. Emerg. Technol.* 10, 486–490. <https://doi.org/10.1016/j.ifset.2009.06.005>
- Patil, S., Valdramidis, V.P., Cullen, P.J., Frias, J.M., Bourke, P., 2010. Ozone inactivation of acid stressed *Listeria monocytogenes* and *Listeria innocua* in orange juice using a bubble column. *Food Control.* <https://doi.org/10.1016/j.foodcont.2010.04.031>
- Pearson, J.P., Pesci, E.C., Iglewski, B.H., 1997. Roles of *Pseudomonas aeruginosa* las and rhl quorum-sensing systems in control of elastase and rhamnolipid biosynthesis genes. *J. Bacteriol.* 179, 5756–67.
- Peeters, E., Nelis, H.J., Coenye, T., 2008. Comparison of multiple methods for quantification

of microbial biofilms grown in microtiter plates. *J. Microbiol. Methods* 72, 157–65.

<https://doi.org/10.1016/j.mimet.2007.11.010>

Percival, S., Chalmers, R., Embrey, M., Hunter, P., Sellwood, J., Wyn-Jones, P., 2004.

*Microbiology of waterborne diseases*. Elsevier Academic Press.

Perle, M., Kimchie, S., Shelef, G., 1995. Some biochemical aspects of the anaerobic

degradation of dairy wastewater. *Water Res.* 29, 1549–1554.

[https://doi.org/10.1016/0043-1354\(94\)00248-6](https://doi.org/10.1016/0043-1354(94)00248-6)

Perni, S., Shama, G., Kong, M.G., 2008. Cold Atmospheric Plasma Disinfection of Cut Fruit

Surfaces Contaminated with Migrating Microorganisms. *J. Food Prot.* 1619–1625.

Petala, M., Samaras, P., Zouboulis, A., Kungolos, A., Sakellaropoulos, G.P., 2008. Influence

of ozonation on the in vitro mutagenic and toxic potential of secondary effluents. *Water*

*Res.* 42, 4929–4940. <https://doi.org/10.1016/j.watres.2008.09.018>

Phillips, C.A., 2016. Bacterial biofilms in food processing environments: a review of recent

developments in chemical and biological control. *Int. J. Food Sci. Technol.* 51, 1731–

1743. <https://doi.org/10.1111/ijfs.13159>

Pin, C., García de Fernando, G.D., Ordóñez, J.A., 2002. Effect of modified atmosphere

composition on the metabolism of glucose by *Brochothrix thermosphacta*. *Appl.*

*Environ. Microbiol.* 68, 4441–7.

Pivovarov, A.A., Tischenko, A.P., 2005. Cold Plasma as a New Tool for Purification of

Wastewater, in: *Modern Tools and Methods of Water Treatment for Improving Living*

*Standards*. Springer-Verlag, Berlin/Heidelberg, pp. 235–244. <https://doi.org/10.1007/1->

Prigent-Combaret, C., Prensier, G., Le Thi, T.T., Vidal, O., Lejeune, P., Dorel, C., 2000.

Developmental pathway for biofilm formation in curli-producing *Escherichia coli* strains: role of flagella, curli and colanic acid. *Environ. Microbiol.* 2, 450–464.

<https://doi.org/10.1046/j.1462-2920.2000.00128.x>

Puchlik, M., Struk-Sokołowska, J., 2017. Comparison of the composition of wastewater from fruit and vegetables as well as dairy industry. *E3S Web Conf.* 17.

Puga, C.H., SanJose, C., Orgaz, B., 2014. Spatial distribution of *Listeria monocytogenes* and *Pseudomonas fluorescens* in mixed biofilms, in: *Listeria Monocytogenes: Food Sources, Prevalence and Management Strategies*.

Raengpradub, S., Wiedmann, M., Boor, K.J., 2008. Comparative analysis of the ??B-dependent stress responses in *Listeria monocytogenes* and *Listeria innocua* strains exposed to selected stress conditions. *Appl. Environ. Microbiol.*

<https://doi.org/10.1128/AEM.00951-07>

Rangel-Marrón, M., López-Malo, A., 2012. Cambios en frutas tropicales frescas, cortadas y empacadas en atmósfera modificada durante su almacenamiento en refrigeración 94–109.

Rao, D.N., Sachindra, N.M., 2002. MODIFIED ATMOSPHERE AND VACUUM PACKAGING OF MEAT AND POULTRY PRODUCTS.

<http://dx.doi.org/10.1081/FRI-120016206>.

Raposo, A., Pérez, E., Faria, C.T., Ferrús, M.A., Carrascosa, C., 2017. Food Spoilage by

*Pseudomonas* spp.—An Overview. *Foodborne Pathog. Antibiot. Resist.*, Wiley Online Books. <https://doi.org/doi:10.1002/9781119139188.ch3>

Rauch, M., Luo, Q., Müller-Altrock, S., Goebel, W., 2005. SigB-dependent in vitro transcription of *prfA* and some newly identified genes of *Listeria monocytogenes* whose expression is affected by PrfA in vivo. *J. Bacteriol.*  
<https://doi.org/10.1128/JB.187.2.800-804.2005>

Rawat, S., 2015. Food Spoilage : Microorganisms and their prevention. *Asian J. Plant Sci. Res.*

Reszka, K.J., Bilski, P.J., Britigan, B.E., 2010. Quenching of singlet oxygen by pyocyanin and related phenazines. *Photochem. Photobiol.* 86, 742–6.  
<https://doi.org/10.1111/j.1751-1097.2010.00728.x>

Reuter, S., Winter, J., Schmidt-Bleker, A., Tresp, H., Hammer, M.U., Weltmann, K.-D., 2012. Controlling the Ambient Air Affected Reactive Species Composition in the Effluent of an Argon Plasma Jet. *IEEE Trans. Plasma Sci.* 40, 2788–2794.  
<https://doi.org/10.1109/TPS.2012.2204280>

Rice, E.W., Fox, K.R., Miltner, R.J., Lytle, D.A., Johnson, C.H., 1996. Evaluating plant performance with endospores. *J. Am. Water Work. Assoc.* 88, 122–30.

Rød, S.K., Hansen, F., Leipold, F., Knøchel, S., 2012. Cold atmospheric pressure plasma treatment of ready-to-eat meat: Inactivation of *Listeria innocua* and changes in product quality. *Food Microbiol.* <https://doi.org/10.1016/j.fm.2011.12.018>

Rodriguez-Romo, L. a, Yousef, A.E., 2005. Inactivation of *Salmonella enterica* serovar

Enteritidis on shell eggs by ozone and UV radiation. *J. Food Prot.*

<https://doi.org/10.4315/0362-028X-68.4.711>

Rose, L.J., O'Connell, H., 2009. UV Light Inactivation of Bacterial Biothreat Agents. *Appl.*

*Environ. Microbiol.* 75, 2987–2990. <https://doi.org/10.1128/AEM.02180-08>

Rowan, N.J., Deans, K., Anderson, J.G., Gemmell, C.G., Hunter, I.S., Chaithong, T., 2001.

Putative Virulence Factor Expression by Clinical and Food Isolates of *Bacillus* spp. after Growth in Reconstituted Infant Milk Formulae. *Appl. Environ. Microbiol.*

<https://doi.org/10.1128/AEM.67.9.3873-3881.2001>

Rutherford, S.T., Bassler, B.L., 2012. Bacterial Quorum Sensing: Its Role in Virulence and

Possibilities for Its Control. *Cold Spring Harb. Perspect. Med.* 2, a012427–a012427.

<https://doi.org/10.1101/cshperspect.a012427>

Ryan, S., Begley, M., Gahan, C.G.M., Hill, C., 2009. Molecular characterization of the

arginine deiminase system in *Listeria monocytogenes*: regulation and role in acid tolerance. *Environ. Microbiol.* <https://doi.org/10.1111/j.1462-2920.2008.01782.x>

Saá Ibusquiza, P., Herrera, J.J.R., Vázquez-Sánchez, D., Cabo, M.L., 2012. Adherence

kinetics, resistance to benzalkonium chloride and microscopic analysis of mixed biofilms formed by *Listeria monocytogenes* and *Pseudomonas putida*. *Food Control* 25,

202–210. <https://doi.org/10.1016/j.foodcont.2011.10.002>

Sagong, H.-G., Lee, S.-Y., Chang, P.-S., Heu, S., Ryu, S., Choi, Y.-J., Kang, D.-H., 2011.

Combined effect of ultrasound and organic acids to reduce *Escherichia coli* O157:H7, *Salmonella Typhimurium*, and *Listeria monocytogenes* on organic fresh lettuce. *Int. J.*

Food Microbiol. 145, 287–292. <https://doi.org/10.1016/j.ijfoodmicro.2011.01.010>

Sala, F.J., Burgos, J., Condón, S., Lopez, P., Raso, J., 1995. Effect of heat and ultrasound on microorganisms and enzymes, in: *New Methods of Food Preservation*. Springer US, Boston, MA, pp. 176–204. [https://doi.org/10.1007/978-1-4615-2105-1\\_9](https://doi.org/10.1007/978-1-4615-2105-1_9)

Saldaña, Z., Sánchez, E., Xicohtencatl-Cortes, J., Puente, J.L., Giron, J.A., 2011. Surface Structures Involved in Plant Stomata and Leaf Colonization by Shiga-Toxigenic *Escherichia Coli* O157:H7. *Front. Microbiol.* 2, 119. <https://doi.org/10.3389/FMICB.2011.00119>

Sanchez-Vizueté, P., Orgaz, B., Aymerich, S., Le Coq, D., Briandet, R., 2015. Pathogens protection against the action of disinfectants in multispecies biofilms. *Front. Microbiol.* 6, 705. <https://doi.org/10.3389/fmicb.2015.00705>

Sarangapani, C., Dixit, Y., Milosavljevic, V., Bourke, P., Sullivan, C., Cullen, P.J., 2017. Optimization of atmospheric air plasma for degradation of organic dyes in wastewater. *Water Sci. Technol.* 75, 207–219. <https://doi.org/10.2166/wst.2016.471>

Sarangapani C, Patange A, Bourke P, Keener K, Cullen PJ, 2018. Recent Advances in the Application of Cold Plasma Technology in Foods. *Annu. Rev. Food Sci. Technol.* 9, 609–629. <https://doi.org/10.1146/annurev-food-030117-012517>

Satoh, K., MacGregor, S.J., Anderson, J.G., Woolsey, G.A., Fouracre, R.A., 2007. Pulsed-plasma disinfection of water containing *Escherichia coli*. *Japanese J. Appl. Physics, Part 1 Regul. Pap. Short Notes Rev. Pap.* <https://doi.org/10.1143/JJAP.46.1137>

Scherba, G., Weigel, R.M., O'Brien, W.D., 1991. Quantitative assessment of the germicidal

- efficacy of ultrasonic energy. *Appl. Environ. Microbiol.* 57, 2079–84.
- Schmid, B., Klumpp, J., Raimann, E., Loessner, M.J., Stephan, R., Tasara, T., 2009. Role of cold shock proteins in growth of *Listeria monocytogenes* under cold and osmotic stress conditions. *Appl. Environ. Microbiol.* <https://doi.org/10.1128/AEM.02154-08>
- Schmidt-Bleker, A., Winter, J., Bösel, A., Reuter, S., Weltmann, K.-D., 2016. On the plasma chemistry of a cold atmospheric argon plasma jet with shielding gas device. *Plasma Sources Sci. Technol.* <https://doi.org/10.1088/0963-0252/25/1/015005>
- Schnabel, U., Sydow, D., Schlüter, O., Andrasch, M., Ehlbeck, J., 2015. Decontamination of Fresh-Cut Iceberg Lettuce and Fresh Mung Bean Sprouts by Non-Thermal Atmospheric Pressure Plasma Processed Water (PPW). *Mod. Agric. Sci. Technol.* 1, 23–39. [https://doi.org/10.15341/mast\(2375-9402\)/01.01.2015/003](https://doi.org/10.15341/mast(2375-9402)/01.01.2015/003)
- Schneider, J., Akbar, M.I., Dutroncy, J., Kiesler, D., Leins, M., Schulz, A., Walker, M., Schumacher, U., Stroth, U., 2009. Silicon Oxide Barrier Coatings Deposited on Polymer Materials for Applications in Food Packaging Industry. *Plasma Process. Polym.* 6, S700–S704. <https://doi.org/10.1002/ppap.200931702>
- Scortti, M., Monzó, H.J., Lacharme-Lora, L., Lewis, D.A., Vázquez-Boland, J.A., 2007. The PrfA virulence regulon. *Microbes Infect.* <https://doi.org/10.1016/j.micinf.2007.05.007>
- Scott, D.B., Leshner, E.C., 1963. Effect of ozone on survival and permeability of *Escherichia coli*. *J. Bacteriol.* 85, 567–76.
- Seeliger, H.P.R., Höhne, K., 1979. Serotyping of *Listeria monocytogenes* and Related Species. *Methods Microbiol.* [https://doi.org/10.1016/S0580-9517\(08\)70372-6](https://doi.org/10.1016/S0580-9517(08)70372-6)



- Setlow, P., 2007. I will survive: DNA protection in bacterial spores. *Trends Microbiol.* 15, 172–80. <https://doi.org/10.1016/j.tim.2007.02.004>
- Setlow, P., 2001. Resistance of spores of *Bacillus* species to ultraviolet light. *Environ. Mol. Mutagen.* 38, 97–104.
- Setlow, P., Johnson, E.A., 2013. Spores and Their Significance, in: *Food Microbiology*. American Society of Microbiology, pp. 45–79. <https://doi.org/10.1128/9781555818463.ch3>
- Seymour, I.J., Burfoot, D., Smith, R.L., Cox, L.A., Lockwood, A., 2002. Ultrasound decontamination of minimally processed fruits and vegetables. *Int. J. Food Sci. Technol.* 37, 547–557. <https://doi.org/10.1046/j.1365-2621.2002.00613.x>
- Sharma, A., Collins, G., Pruden, A., 2009. Differential gene expression in *Escherichia coli* following exposure to nonthermal atmospheric pressure plasma. *J. Appl. Microbiol.* <https://doi.org/10.1111/j.1365-2672.2009.04323.x>
- Shaw, R.K., Berger, C.N., Feys, B., Knutton, S., Pallen, M.J., Frankel, G., 2008. Enterohemorrhagic *Escherichia coli* Exploits EspA Filaments for Attachment to Salad Leaves. *Appl. Environ. Microbiol.* 74, 2908–2914. <https://doi.org/10.1128/AEM.02704-07>
- Shete, B., Shinkar, N.P., 2013. Comparative Study of Various Treatments For Dairy Industry Wastewater. *IOSR J. Eng.* <https://doi.org/10.9790/3021-03844247>
- Shimizu, T., Iwafuchi, Y., Morfill, G.E., Sato, T., 2011. Formation of thermal flow fields and chemical transport in air and water by atmospheric plasma. *New J. Phys.*

<https://doi.org/10.1088/1367-2630/13/5/053025>

Simões, M., Simões, L.C., Vieira, M.J., 2009. Species association increases biofilm resistance to chemical and mechanical treatments. *Water Res.*

<https://doi.org/10.1016/j.watres.2008.10.010>

Sinisterra, J. V, 1992. Application of ultrasound to biotechnology: an overview. *Ultrasonics* 30, 180–5.

Soli, K.W., Yoshizumi, A., Motomatsu, A., Yamakawa, M., Yamasaki, M., Mishima, T., Miyaji, N., Honjoh, K.I., Miyamoto, T., 2010. Decontamination of fresh produce by the use of slightly acidic hypochlorous water following pretreatment with sucrose fatty acid ester under microbubble generation. *Food Control.*

<https://doi.org/10.1016/j.foodcont.2010.02.009>

Solomon, E.B., Niemira, B.A., Sapers, G.M., Annous, B.A., 2005. Biofilm formation, cellulose production, and curli biosynthesis by *Salmonella* originating from produce, animal, and clinical sources. *J. Food Prot.* 68, 906–12.

Spellman, F., 2014. *Water Treatment Operations.*, in: *Handbook of Water and Wastewater Treatment Plant Operations.* CRC Press, Boca Raton, pp. 642–654.

Srey, S., Jahid, I.K., Ha, S.-D., 2013. Biofilm formation in food industries: A food safety concern. *Food Control* 31, 572–585. <https://doi.org/10.1016/j.foodcont.2012.12.001>

Stanley, G., Shaw, K.J., Egan, A.F., 1981. Volatile Compounds Associated with Spoilage of Vacuum-Packaged Sliced Luncheon Meat by *Brochothrix thermosphacta*. *Appl. Environ. Microbiol.* 41, 816–8.

- Stepanović, S., Cirković, I., Ranin, L., Svabić-Vlahović, M., 2004. Biofilm formation by *Salmonella* spp. and *Listeria monocytogenes* on plastic surface. *Lett. Appl. Microbiol.* 38, 428–32. <https://doi.org/10.1111/j.1472-765X.2004.01513.x>
- Stepanović, S., Vuković, D., Dakić, I., Savić, B., Švabić-Vlahović, M., 2000. A modified microtiter-plate test for quantification of staphylococcal biofilm formation. *J. Microbiol. Methods* 40, 175–179. [https://doi.org/10.1016/S0167-7012\(00\)00122-6](https://doi.org/10.1016/S0167-7012(00)00122-6)
- Stewart, P.S., 2015. Antimicrobial Tolerance in Biofilms. *Microbiol. Spectr.* 3. <https://doi.org/10.1128/microbiolspec.MB-0010-2014>
- Sun, S.H., Kim, S.J., Kwak, S.J., Yoon, K.S., 2012. Efficacy of sodium hypochlorite and acidified sodium chlorite in preventing browning and microbial growth on fresh-cut produce. *Prev. Nutr. Food Sci.* 17, 210–216. <https://doi.org/10.3746/pnf.2012.17.3.210>
- Surowsky, B., Bußler, S., Schlüter, O.K., Cullen, P.J., 2016. Cold Plasma Interactions With Food Constituents in Liquid and Solid Food Matrices, in: *Cold Plasma in Food and Agriculture : Fundamentals and Applications*. Academic Press, pp. 179–203. <https://doi.org/10.1016/B978-0-12-801365-6.00007-X>
- Suslow, T., 1997. Postharvest Chlorination: Basic Properties & Key Points for Effective Distribution. University of California, Division of Agriculture and Natural Resources. <https://doi.org/10.3733/ucanr.8003>
- Sutherland, I.W., 2001. The biofilm matrix – an immobilized but dynamic microbial environment. *Trends Microbiol.* 9, 222–227. [https://doi.org/10.1016/S0966-842X\(01\)02012-1](https://doi.org/10.1016/S0966-842X(01)02012-1)

- Swaminathan, B., Gerner-Smidt, P., 2007. The epidemiology of human listeriosis. *Microbes Infect.* <https://doi.org/10.1016/j.micinf.2007.05.011>
- Sztajer, H., Szafranski, S.P., Tomasch, J., Reck, M., Nimtz, M., Rohde, M., Wagner-Döbler, I., 2014. Cross-feeding and interkingdom communication in dual-species biofilms of *Streptococcus mutans* and *Candida albicans*. *ISME J.* 8, 2256–71.  
<https://doi.org/10.1038/ismej.2014.73>
- Tan, C.H., Lee, K.W.K., Burmølle, M., Kjelleberg, S., Rice, S.A., 2017. All together now: experimental multispecies biofilm model systems. *Environ. Microbiol.* 42–53.  
<https://doi.org/10.1111/1462-2920.13594>
- Tapp, C., Rice, R.G., 2012. Generation and Control of Ozone, in: *Ozone in Food Processing*. Wiley-Blackwell, Oxford, UK, pp. 33–54. <https://doi.org/10.1002/9781118307472.ch4>
- Temiz, A., Bağcı, U., Toğay, S.Ö., 2011. Efficacy of different decontamination treatments on microbial population of leafy vegetables. *GIDA* 36, 9–15.
- Tendero, C., Tixier, C., Tristant, P., Desmaison, J., Leprince, P., 2006. Atmospheric pressure plasmas: A review. *Spectrochim. Acta Part B At. Spectrosc.* 61, 2–30.  
<https://doi.org/10.1016/j.sab.2005.10.003>
- The Council of the European Communities, 1991. Council Directive 91/271/EEC of 21 May 1991 concerning urban waste-water treatment.
- Thirumdas, R., Sarangapani, C., Annapure, U.S., 2015. Cold Plasma: A novel Non-Thermal Technology for Food Processing. *Food Biophys.* 10, 1–11.  
<https://doi.org/10.1007/s11483-014-9382-z>

- Tian, Y., Ma, R., Zhang, Q., Feng, H., Liang, Y., Zhang, J., Fang, J., 2015. Assessment of the physicochemical properties and biological effects of water activated by non-thermal plasma above and beneath the water surface. *Plasma Process. Polym.*  
<https://doi.org/10.1002/ppap.201400082>
- Timoshkin, I. V., Maclean, M., Wilson, M.P., Given, M.J., MacGregor, S.J., Wang, T., Anderson, J.G., 2012. Bactericidal Effect of Corona Discharges in Atmospheric Air. *Plasma Sci. IEEE Trans.* <https://doi.org/10.1109/TPS.2012.2193621>
- Toledo-Arana, A., Dussurget, O., Nikitas, G., Sesto, N., Guet-Revillet, H., Balestrino, D., Loh, E., Gripenland, J., Tiensuu, T., Vaitkevicius, K., Barthelemy, M., Vergassola, M., Nahori, M.A., Soubigou, G., Régnault, B., Coppée, J.Y., Lecuit, M., Johansson, J., Cossart, P., 2009. The *Listeria* transcriptional landscape from saprophytism to virulence. *Nature.* <https://doi.org/10.1038/nature08080>
- Tournas, V.H., 2005. Spoilage of vegetable crops by bacteria and fungi and related health hazards. *Crit. Rev. Microbiol.* 31, 33–44. <https://doi.org/10.1080/10408410590886024>
- Tran, N., Amidi, M., Sanguansri, P., 2008. Cool plasma for large scale chemical-free microbial inactivation of surfaces. *Food Aust.* 60, 344–347.
- Travier, L., Guadagnini, S., Gouin, E., Dufour, A., Chenal-Francisque, V., Cossart, P., Olivo-Marin, J.C., Ghigo, J.M., Disson, O., Lecuit, M., 2013. ActA Promotes *Listeria monocytogenes* Aggregation, Intestinal Colonization and Carriage. *PLoS Pathog.* <https://doi.org/10.1371/journal.ppat.1003131>
- Traylor, M.J., Pavlovich, M.J., Karim, S., Hait, P., Sakiyama, Y., Clark, D.S., Graves, D.B.,

2011. Long-term antibacterial efficacy of air plasma-activated water. *J. Phys. D. Appl. Phys.* <https://doi.org/10.1088/0022-3727/44/47/472001>
- Tsegaye, M., Ashenafi, M., 2005. Fate of *Escherichia coli* O157:H7 during the processing and storage of Ergo and Ayib, traditional Ethiopian dairy products. *Int. J. Food Microbiol.* 103, 11–21. <https://doi.org/10.1016/j.ijfoodmicro.2004.12.006>
- U.S. Food and Drug Administration, 2015. Safe Practices For Food Processes [WWW Document]. URL <http://www.fda.gov/Food/FoodScienceResearch/SafePracticesforFoodProcesses/default.htm> (accessed 7.22.16).
- U S Environmental Protection Agency, 2012. 2012 Guidelines for Water Reuse. Development. <https://doi.org/EPA16251R-921004>
- Ulbin-Figlewicz, N., Jarmoluk, A., Marycz, K., 2014. Antimicrobial activity of low-pressure plasma treatment against selected foodborne bacteria and meat microbiota. *Ann. Microbiol.* 65, 1537–1546. <https://doi.org/10.1007/s13213-014-0992-y>
- US EPA, 2004. Effluent Limitations Guidelines and Standards for the Meat and Poultry Products Industry Point Source Category.
- Utratna, M., Shaw, I., Starr, E., O’Byrne, C.P., 2011. Rapid, transient, and proportional activation of  $\sigma$  B in response to osmotic stress in *Listeria monocytogenes*. *Appl. Environ. Microbiol.* <https://doi.org/10.1128/AEM.05732-11>
- Valta, K., Kosanovic, T., Malamis, D., Moustakas, K., Loizidou, M., 2015. Overview of water usage and wastewater management in the food and beverage industry. *Desalin.*

Water Treat. 53, 12. <https://doi.org/10.1080/19443994.2014.934100>

Valta, K., Moustakas, K., Sotiropoulos, A., Malamis, D., Haralambous, K.J., 2016.

Adaptation measures for the food and beverage industry to the impact of climate change on water availability. *Desalin. Water Treat.* 57, 2336–2343.

<https://doi.org/10.1080/19443994.2015.1049407>

van Bokhorst-van de Veen, H., Xie, H., Esveld, E., Abee, T., Mastwijk, H., Nierop Groot, M., 2015. Inactivation of chemical and heat-resistant spores of *Bacillus* and *Geobacillus* by nitrogen cold atmospheric plasma evokes distinct changes in morphology and integrity of spores. *Food Microbiol.* <https://doi.org/10.1016/j.fm.2014.03.018>

van der Steen, J.B., Ávila-Pérez, M., Knippert, D., Vreugdenhil, A., van Alphen, P., Hellingwerf, K.J., 2012. Differentiation of function among the RsbR paralogs in the general stress response of *Bacillus subtilis* with regard to light perception. *J. Bacteriol.* <https://doi.org/10.1128/JB.06705-11>

Van Haute, S., López-Gálvez, F., Gómez-López, V.M., Eriksson, M., Devlieghere, F., Allende, A., Sampers, I., 2015. Methodology for modeling the disinfection efficiency of fresh-cut leafy vegetables wash water applied on peracetic acid combined with lactic acid. *Int. J. Food Microbiol.* <https://doi.org/10.1016/j.ijfoodmicro.2015.05.020>

Van Haute, S., Sampers, I., Holvoet, K., Uyttendaele, M., 2013. Physicochemical Quality and Chemical Safety of Chlorine as a Reconditioning Agent and Wash Water Disinfectant for Fresh-Cut Lettuce Washing. *Appl. Environ. Microbiol.* 79, 2850–2861. <https://doi.org/10.1128/AEM.03283-12>

- Van Haute, S., Sampers, I., Jacxsens, L., Uyttendaele, M., 2015. Selection Criteria for Water Disinfection Techniques in Agricultural Practices. *Crit. Rev. Food Sci. Nutr.*  
<https://doi.org/10.1080/10408398.2012.705360>
- Van Impe, J., Smet, C., Tiwari, B., Greiner, R., Ojha, S., Stulić, V., Vukušić, T., Režek Jambrak, A., 2018. State of the art of nonthermal and thermal processing for inactivation of micro-organisms. *J. Appl. Microbiol.* 125, 16–35. <https://doi.org/10.1111/jam.13751>
- Vandamm, J.P., Li, D., Harris, L.J., Schaffner, D.W., Danyluk, M.D., 2013. Fate of *Escherichia coli* O157: H7, *Listeria monocytogenes*, and *Salmonella* on fresh-cut celery. *Food Microbiol.* <https://doi.org/10.1016/j.fm.2012.11.016>
- Varzakas, T.H., Arvanitoyannis, I.S., 2008. Application of ISO22000 and comparison to HACCP for processing of ready to eat vegetables: Part I. *Int. J. Food Sci. Technol.* 43, 1729–1741. <https://doi.org/10.1111/j.1365-2621.2007.01675.x>
- Venkitanarayanan, K., Upadhyay, A., Nair, M.S., Upadhyaya, I., 2017. The Effects of Environmental Conditions and External Treatments on Virulence of Foodborne Pathogens, in: Gurtler, J.B., Doyle, M.P., Kornacki, J.L. (Eds.), *Foodborne Pathogens: Virulence Factors and Host Susceptibility*. Springer International Publishing, Cham, pp. 305–332. [https://doi.org/10.1007/978-3-319-56836-2\\_10](https://doi.org/10.1007/978-3-319-56836-2_10)
- Villagómez, N.S., Herrera, E.A.N., Orozco R., L., Wild-Padua, G., Iturriaga, M.H., 2010. Effect of storage time on the efficacy of chemical and irradiation treatments to inactivate *Salmonella* on cilantro (*Coriandrum sativum* L.). *J. Food Saf.* 30, 584–598.  
<https://doi.org/10.1111/j.1745-4565.2010.00227.x>



- Vivijs, B., Aertsen, A., Michiels, C.W., 2016. Identification of genes required for growth of *Escherichia coli* MG1655 at moderately low pH. *Front. Microbiol.* 7, 1672.  
<https://doi.org/10.3389/fmicb.2016.01672>
- Vos, P., Garrity, G., Jones, D., Krieg, N.R., Ludwig, W., Rainey, F.A., Schleifer, K.H., Whitman, W., 2011. *Bergey's Manual of Systematic Bacteriology: Volume 3: The Firmicutes*, 2nd ed, *Bergey's Manual of Systematic Bacteriology*. Springer New York.
- Vourch, M., Balannec, B., Chaufer, B., Dorange, G., 2008. Treatment of dairy industry wastewater by reverse osmosis for water reuse. *Desalination* 219, 190–202.  
<https://doi.org/10.1016/j.desal.2007.05.013>
- Wagner, H.-E., Brandenburg, R., Kozlov, K.V., Sonnenfeld, A., Michel, P., Behnke, J.F., 2003. The barrier discharge: basic properties and applications to surface treatment. *Vacuum* 71, 417–436. [https://doi.org/10.1016/S0042-207X\(02\)00765-0](https://doi.org/10.1016/S0042-207X(02)00765-0)
- Wang, J., Zhuang, H., Hinton, A., Zhang, J., 2016. Influence of in-package cold plasma treatment on microbiological shelf life and appearance of fresh chicken breast fillets. *Food Microbiol.* <https://doi.org/10.1016/j.fm.2016.07.007>
- Wang, R.X., Nian, W.F., Wu, H.Y., Feng, H.Q., Zhang, K., Zhang, J., Zhu, W.D., Becker, K.H., Fang, J., 2012. Atmospheric-pressure cold plasma treatment of contaminated fresh fruit and vegetable slices: Inactivation and physiochemical properties evaluation. *Eur. Phys. J. D.* <https://doi.org/10.1140/epjd/e2012-30053-1>
- Warning, A., Datta, A.K., 2013. Interdisciplinary engineering approaches to study how pathogenic bacteria interact with fresh produce. *J. Food Eng.*

<https://doi.org/10.1016/j.jfoodeng.2012.09.004>

Warriner, K., Huber, A., Namvar, A., Fan, W., Dunfield, K., 2009. Recent Advances in the Microbial Safety of Fresh Fruits and Vegetables. *Adv. Food Nutr. Res.*

[https://doi.org/10.1016/S1043-4526\(09\)57004-0](https://doi.org/10.1016/S1043-4526(09)57004-0)

Waters, C.M., Lu, W., Rabinowitz, J.D., Bassler, B.L., 2008. Quorum sensing controls biofilm formation in *Vibrio cholerae* through modulation of cyclic di-GMP levels and repression of *vpsT*. *J. Bacteriol.* 190, 2527–36. <https://doi.org/10.1128/JB.01756-07>

Watson, K., Shaw, G., Leusch, F.D.L., Knight, N.L., 2012. Chlorine disinfection by-products in wastewater effluent: Bioassay-based assessment of toxicological impact. *Water Res.* 46, 6069–6083. <https://doi.org/10.1016/j.watres.2012.08.026>

Wei, W., Wang, X., Xie, Z., Wang, W., Xu, J., Liu, Y., Gao, H., Zhou, Y., 2017. Evaluation of sanitizing methods for reducing microbial contamination on fresh strawberry, cherry tomato, and red bayberry. *Front. Microbiol.* 9, 2397.

<https://doi.org/10.3389/fmicb.2017.02397>

Wells-Bennik, M.H.J., Eijlander, R.T., den Besten, H.M.W., Berendsen, E.M., Warda, A.K., Krawczyk, A.O., Nierop Groot, M.N., Xiao, Y., Zwietering, M.H., Kuipers, O.P., Abee, T., 2016. Bacterial Spores in Food: Survival, Emergence, and Outgrowth. *Annu. Rev. Food Sci. Technol.* 7, 457–482. <https://doi.org/10.1146/annurev-food-041715-033144>

Wemekamp-Kamphuis, H.H., Wouters, J.A., de Leeuw, P.P.L.A., Hain, T., Chakraborty, T., Abee, T., 2004. Identification of sigma factor sigma B-controlled genes and their impact on acid stress, high hydrostatic pressure, and freeze survival in *Listeria monocytogenes*

EGD-e. *Appl. Environ. Microbiol.* <https://doi.org/10.1128/AEM.70.6.3457-3466.2004>

Wiedmann, M., Arvik, T.J., Hurley, R.J., Boor, K.J., 1998. General stress transcription factor sigmaB and its role in acid tolerance and virulence of *Listeria monocytogenes*. *J. Bacteriol.*

Williams, R.C., Sumner, S.S., Golden, D.A., 2005. Inactivation of *Escherichia coli* O157:H7 and *Salmonella* in Apple Cider and Orange Juice Treated with Combinations of Ozone, Dimethyl Dicarbonate, and Hydrogen Peroxide. *J. Food Sci.* 70, M197–M201.  
<https://doi.org/10.1111/j.1365-2621.2005.tb07188.x>

Wu, H., Sun, P., Feng, H., Zhou, H., Wang, R., Liang, Y., Lu, J., Zhu, W., Zhang, J., Fang, J., 2012. Reactive Oxygen Species in a Non-thermal Plasma Microjet and Water System: Generation, Conversion, and Contributions to Bacteria Inactivation-An Analysis by Electron Spin Resonance Spectroscopy. *Plasma Process. Polym.*  
<https://doi.org/10.1002/ppap.201100065>

WWAP, 2012. World Water Assessment Programme. The United Nations World Water Development Report 2012: Managing Water under Uncertainty and Risk. Paris.

WWAP (United Nations World Water Assessment Programme), 2017. The United Nations World Water Development Report 2017. Wastewater: The Untapped Resource, The United Nations World Water Development Report.  
<https://doi.org/10.1017/CBO9781107415324.004>

Xiang, Q., Liu, X., Liu, S., Ma, Y., Xu, C., Bai, Y., 2019. Effect of plasma-activated water on microbial quality and physicochemical characteristics of mung bean sprouts. *Innov.*

Food Sci. Emerg. Technol. 52, 49–56. doi:<https://doi.org/10.1016/j.ifset.2018.11.012>

Xu, Z., Wei, J., Shen, J., Liu, Y., Ma, R., Zhang, Z., Qian, S., Ma, J., Lan, Y., Zhang, H., Zhao, Y., Xia, W., Sun, Q., Cheng, C., Chu, P.K., 2015. Genetic effects of an air discharge plasma on *Staphylococcus aureus* at the gene transcription level. *Appl. Phys. Lett.* <https://doi.org/10.1063/1.4921754>

Yaron, S., Römling, U., 2014. Biofilm formation by enteric pathogens and its role in plant colonization and persistence. *Microb. Biotechnol.* 7, 496–516.  
<https://doi.org/10.1111/1751-7915.12186>

Yildiz, F., 1994. Initial Preparation, Handling, and Distribution of Minimally Processed Refrigerated Fruits and Vegetables, in: Wiley, R.C. (Ed.), *Minimally Processed Refrigerated Fruits & Vegetables*. Springer US, Boston, MA, pp. 15–65.  
[https://doi.org/10.1007/978-1-4615-2393-2\\_2](https://doi.org/10.1007/978-1-4615-2393-2_2)

Yuk, H.-G., Yoo, M.-Y., Yoon, J.-W., Moon, K.-D., Marshall, D.L., Oh, D.-H., 2006. Effect of Combined Ozone and Organic Acid Treatment for Control of *Escherichia coli* O157:H7 and *Listeria monocytogenes* on Lettuce. *J. Food Sci.* 71, M83–M87.  
<https://doi.org/10.1111/j.1365-2621.2006.tb15636.x>

Yusupov, M., Bogaerts, A., Huygh, S., Snoeckx, R., Duin, A.C.T. van, Neyts, E.C., 2013. Plasma-Induced Destruction of Bacterial Cell Wall Components: A Reactive Molecular Dynamics Simulation.

Zeraik, A.E., Nitschke, M., 2012. Influence of growth media and temperature on bacterial adhesion to polystyrene surfaces. *Brazilian Arch. Biol. Technol.* 55, 569–576.

<https://doi.org/10.1590/S1516-89132012000400012>

Zhang, M., Oh, J.K., Cisneros-Zevallos, L., Akbulut, M., 2013. Bactericidal effects of nonthermal low-pressure oxygen plasma on *S. typhimurium* LT2 attached to fresh produce surfaces. *J. Food Eng.* <https://doi.org/10.1016/j.jfoodeng.2013.05.045>

Zhao, C., Ge, B., De Villena, J., Sudler, R., Yeh, E., Zhao, S., White, D.G., Wagner, D., Meng, J., 2001. Prevalence of *Campylobacter* spp., *Escherichia coli*, and *Salmonella* Serovars in Retail Chicken, Turkey, Pork, and Beef from the Greater Washington, D.C., Area. *Appl. Environ. Microbiol.* 67, 5431–5436.  
<https://doi.org/10.1128/AEM.67.12.5431-5436.2001>

Zhu, J., Mekalanos, J.J., 2003. Quorum Sensing-Dependent Biofilms Enhance Colonization in *Vibrio cholerae*. *Dev. Cell* 5, 647–656. [https://doi.org/10.1016/S1534-5807\(03\)00295-8](https://doi.org/10.1016/S1534-5807(03)00295-8)

Zhuang, H., Barth, M.M., HILDEBRAND, D.F., 1994. Packaging Influenced Total Chlorophyll, Soluble Protein, Fatty Acid Composition and Lipoxygenase Activity in Broccoli Florets. *J. Food Sci.* <https://doi.org/10.1111/j.1365-2621.1994.tb14669.x>

Ziuzina, D., Han, L., Cullen, P.J., Bourke, P., 2015. Cold plasma inactivation of internalised bacteria and biofilms for *Salmonella enterica* serovar Typhimurium, *Listeria monocytogenes* and *Escherichia coli*. *Int. J. Food Microbiol.* 210, 53–61.  
<https://doi.org/10.1016/j.ijfoodmicro.2015.05.019>

Zuma, F.N., Lin, J., Jonnalagadda, S.B., 2009. Kinetics of inactivation of *Pseudomonas aeruginosa* in aqueous solutions by ozone aeration. *J. Environ. Sci. Health. A. Tox.*

Hazard. Subst. Environ. Eng. 44, 929–35.

Zuhria, F., Sarto, S., Prasetyo, I., 2018. The influence of electrocoagulation on the reduction of COD, BOD, and TSS of Batik industry wastewater. *J. Environ. Sustain.* 2, 100–107.

## List of Publications

**Patange, A.,** Boehm, D., Zuizina, D., Cullen, P.J., Gilmore, B., Bourke, P., 2019. High voltage atmospheric cold air plasma control of bacterial biofilms on fresh produce. *Int. J. Food Microbiol.*

**Patange, A.,** Boehm, D., Giltrap, M., Lu, P., Cullen, P. and Bourke, P. (2018). Assessment of the disinfection capacity and eco-toxicological impact of atmospheric cold plasma for treatment of food industry effluents. *Science of The Total Environment*, 631-632, pp.298-307.

Sarangapani, C., **Patange, A.,** Bourke, P., Keener, K. and Cullen, P. (2018). Recent Advances in the Application of Cold Plasma Technology in Foods. *Annual Review of Food Science and Technology*, 9(1), pp.609-629.

**Patange, A.,** Boehm, D., Bueno-Ferrer, C., Cullen, P. and Bourke, P. (2017). Controlling *Brochothrix thermosphacta* as a spoilage risk using in-package atmospheric cold plasma. *Food Microbiology*, 66, pp.48-54.

Han, L., Ziuzina, D., Heslin, C., Boehm, D., **Patange, A.,** Sango, D., Valdramidis, V., Cullen, P. and Bourke, P. (2016). Controlling Microbial Safety Challenges of Meat Using High Voltage Atmospheric Cold Plasma. *Frontiers in Microbiology*, 7.

## Under Review

**Patange, A.,** Lu, P., Boehm, D., Cullen, P. and Bourke, P. (2018). Efficacy of Atmospheric cold plasma for fresh produce and wash water treatment. *Food and Bioprocess Technology*, under review.

**Patange, A.,** Boehm, D., O’Byrne., Cullen, P. and Bourke, P. (2018). Assessing Stress effect of Atmospheric cold plasma on bacterial stress responses and virulence using *Listeria monocytogenes* knockout mutants. *Frontier in Microbiology*, under review.

## **Conferences**

Assessing effect of Atmospheric cold plasma on stress responses of *Listeria monocytogenes* mutants. A. Patange, D. Boehm, C. O’Byrne, P.J. Cullen and P. Bourke. Poster presentation at 7<sup>th</sup> International Conference on Plasma Medicine (ICPM), Drexel University, Philadelphia, USA, June 18-22, 2018.

Potential of atmospheric cold plasma treatment for control of bacterial biofilms on fresh produce. A. Patange, D. Boehm, P.J. Cullen, P. Bourke. Oral presentation at International Biodeterioration and Biodegradation Society (IBBS), Manchester Metropolitan University, Manchester, UK, 6–8<sup>th</sup> September 2017.

Atmospheric cold plasma treatment for control of fresh produce bacterial biofilms. A. Patange, D. Boehm, P.J. Cullen, P. Bourke. Oral presentation at 30<sup>th</sup> EFFoST International Conference, Vienna, Austria, 28-30<sup>th</sup> November 2016.

Atmospheric cold plasma treatment of bacterial pathogens in food industry effluent. A. Patange, D. Boehm, P.J. Cullen, P. Bourke. Poster at 18<sup>th</sup> IUFOST World Congress of Food Science and Technology, Dublin, Ireland, 21-25<sup>th</sup> August 2016.

Inactivation of spore forming bacteria and spores by atmospheric cold plasma. A. Patange, D. Boehm, P.J. Cullen, P. Bourke. Poster at 18<sup>th</sup> IUFOST World Congress of Food Science and Technology, Dublin, Ireland, 21-25<sup>th</sup> August 2016.



Atmospheric Cold Plasma treatment of organic constituents and bacterial pathogens in wastewater. A. Patange, C. Sarangapani, D. Boehm, P.J. Cullen and P. Bourke. Oral presentation at ENVIRON 2016, 26th Irish Environmental Researchers' Colloquium, Limerick, Ireland, 22–24th March 2016.

Atmospheric cold plasma treatment of organic constituents and bacterial pathogens in dairy wastewater. A. Patange, D. Boehm, P.J. Cullen and P. Bourke. Poster at 6th Annual Graduate Research Symposium, Dublin Institute of Technology, Dublin, Ireland, 25th November, 2015.

Inactivation of *Brochothrix thermosphacta* by atmospheric cold plasma. A. Patange, D. Boehm, P.J. Cullen and P. Bourke. Poster at FEMS 2015, 6th Congress of European Maastricht, The Netherlands, June 7 – 11, 2015.

## **Awards**

Patange, A., Boehm, D., Cullen, P.J., Bourke, P., 2015. Atmospheric cold plasma treatment of organic constituents and bacterial pathogens in dairy wastewater., in: 6<sup>th</sup> Annual Graduate Research Symposium. [Awarded for Best Poster of 6<sup>th</sup> Annual Graduate Research Symposium]