Masters

Science

2016

Transcutaneous Oximetry (tcpO2) A study to Evaluate the Clinical Role of tcpO2 in the Vascular Patient Cohort and in Particular Those Patients with Foot Ulceration.

Vanessa Tisdall
Technological University Dublin

Follow this and additional works at: <https://arrow.tudublin.ie/scienmas>

Recommended Citation

Tisdall V, (2016) *Transcutaneous Oximetry tcpO2: A study to evaluate the clinical role of tcpO2 in the vascular patient cohort and in particular those patients with foot ulceration*. Masters Thesis, Technological University Dublin, 2016. doi.org/10.21427/54sw-b470

This Theses, Masters is brought to you for free and open access by the Science at ARROW@TU Dublin. It has been accepted for inclusion in Masters by an authorized administrator of ARROW@TU Dublin. For more information, please contact yvonne.desmond@tudublin.ie, arrow.admin@tudublin.ie, brian.widdis@tudublin.ie.



This work is licensed under a [Creative Commons Attribution-Noncommercial-Share Alike 3.0 License](https://creativecommons.org/licenses/by-nc-sa/3.0/)



Transcutaneous Oximetry ($tcpO_2$)

A study to evaluate the clinical role of $tcpO_2$ in the vascular patient cohort and in particular those patients with foot ulceration.

Vanessa Tisdall (Thesis)
Dublin Institute of Technology

Recommended Citation

Tisdall V, $tcpO_2$: A study to evaluate the clinical role of $tcpO_2$ in the vascular patient cohort and in particular those patients with foot ulceration.

Masters Thesis.

Dublin Institute of Technology

2016

This Theses, Masters is brought to you for free and open access by the Science at ARROW@DIT. It has been accepted for inclusion in Masters by an authorized administrator of ARROW@DIT. For more information, please contact yvonne.desmond@dit.ie, arrow.admin@dit.ie.



Transcutaneous Oximetry ($tcpO_2$)

A study to evaluate the clinical role of $tcpO_2$ in the vascular patient cohort and in particular those patients with foot ulceration.

Supervisors: Prof Pat Goodman
Prof Sean Tierney
Ms Bridget Egan

Dept. Of Physics, Dublin Institute of Technology

Submitted to the Dublin Institute of Technology, in partial fulfilment of the requirements leading to the award of MPhil.

2016

Table of contents

Table of contents.....	II
Abstract.....	V
Declaration.....	VII
Acknowledgements.....	VIII
Abbreviations.....	IX
List of Figures.....	X
List of Tables.....	XI
Chapter 1.....	1
Introduction.....	1
Chapter 2.....	4
Diabetes Mellitus and lower limb arterial disease.....	4
Background.....	5
2.0 Diabetes Mellitus – what is it?.....	5
2.0.1 Types of diabetes.....	6
2.0.2 Consequences of diabetes.....	7
2.0.3 Prevalence of diabetes.....	7
2.0.4 Economic cost of diabetes.....	8
2.1 Diabetes and the foot.....	10
2.2 Ulceration.....	11
2.2.1 Atherosclerosis and arterial ulcers:.....	13
Chapter 3.....	15
Lower limb arterial anatomy.....	15
Anatomy.....	16
3.1 Anatomy of the human skin.....	16
3.2 The Macrocirculation.....	20
3.2.1 Anatomy of arteries.....	20
3.2.2 The lower limb arterial anatomy.....	22
3.3 The Microcirculation.....	25

Chapter 4.....	28
Physics and Instrumentation	28
4.0 Physics.....	29
4.0.1 Soundwaves	29
4.0.2 The Doppler Effect	30
4.1 Instrumentation.....	33
4.1.1 Doppler Instruments.....	33
4.1.2 Photo Plethysmography (PPG)	35
4.1.3 The Clark Electrode	37
Chapter 5.....	39
Method of data acquisition.....	39
5.1 Methology.....	40
5.1.1 Patient selection	41
5.2 Demographics	42
5.2.1 Participant demographics.....	42
5.2.2 Test variables	42
5.3 Assessment of Lower limb arterial disease	45
5.3.1 Transcutaneous Oxygen Pressure ($tcpO_2$).....	45
5.3.2 Toe Brachial Indices (TBI's).....	48
Chapter 6.....	52
Comparison of risk factors between $tcpO_2$ versus the absolute toe pressure results. ..	52
6.1 Aim	53
6.2 Method.....	53
6.3 Results	54
6.4 Discussion.....	58
Chapter 7.....	63
Comparison of results between $tcpO_2$ and the TBI tests.....	63
7.1 Aim	64
7.2 Method.....	64
7.3 Results:	64
7.4 Discussion.....	69
7.4.1 Concordant tests	72

7.4.2	Discordant tests	74
Chapter 8	78
Examination of factors affecting ulcer outcomes	78
8.1	Aim	79
8.2	Method.....	79
8.3	Results	79
8.4	Ulceration outcomes	84
8.4.1	Non intervention tests	86
8.4.2	Intervention tests	91
8.5	Discussion.....	93
Chapter 9	96
Conclusion and Recommendations	96
References:	100

Abstract

Introduction: Ulceration is defined as a breakdown of the skin. The treatment of ulcers can be difficult and both time and cost expensive for the patient and health service. Determining what has caused this ulceration and formulating a treatment plan is key. There is no one universally accepted test which can accurately predict if a wound will heal or what treatment will be successful in healing it. Assessing the peripheral arterial system is an important first test to ensure that there is adequate blood perfusion to the ulcerated area. This is carried out by performing a test called Toe Brachial Indices (TBI's).

In 2012 a new test called transcutaneous oximetry ($tcpO_2$) was introduced to the vascular laboratory service in a bid to gain extra information on ulcer diagnosis and potential healing status. This test examines tissue oxygenation levels at a particular site. The purpose of this audit is to determine if $tcpO_2$ provides any additional diagnostic information.

Method: From its introduction in 2012 and for the following three years all results of this test and a set of TBI's were audited. Patients who presented to the vascular service with an active foot ulceration had both tests performed. A medical history was taken to record the risk factors of peripheral arterial disease.

Results: There were a total of 247 patients included in the audit which equated to 310 tests for analysis (a number of patients had tests performed on both feet). The age range was 32 – 94 years old with a mean age of 67.5 years and a median age of 69 years. Both tests were compared. $tcpO_2$ and TBI'S were statistically lower in the smokers in comparison to the non smokers. Absolute toe pressures were statistically lower in the patients on statins and antihypertensives when compared to those not. Neither of these areas are well researched. When all test results were compared 70% of tests had reduced TBI results indicating arterial disease. Of this 70%, 39% had a $tcpO_2$ result which was below a normal threshold suggestive that spontaneous healing was not likely to occur. This group with low TBI's and low $tcpO_2$ had significant numbers of interventions and amputations. More interestingly, the remaining 31% of tests had a $tcpO_2$ test outcome which was above the normal threshold suggestive of spontaneous healing. These tests required a lower number of interventions and amputations when compared to the tests where both results are normal.

Conclusion: In the setting of peripheral arterial disease the addition of $tcpO_2$ does provide additional further diagnostic information that should be taken into consideration with a TBI result when treating foot ulceration. In the absence of a TBI result it is reasonable to consider a $tcpO_2$ test as an alternative source of diagnostic information.

Declaration

I hereby certify that the material which is submitted in this thesis towards award of the **MPhil in Work-based Learning** is entirely my own work and has not been submitted for any academic assessment other than part-fulfilment of the award named above.

Signature of candidate:

Date:

Acknowledgements

Firstly I would like to acknowledge and sincerely thank Lorraine, James and Kay, the wonderful staff of the vascular laboratory in Tallaght hospital, for their endless support and motivation and the numerous times they proof read and re-read the drafts of this thesis. Without their unfailing support and encouragement this work would not have been possible.

I wish to thank Professor Sean Tierney, Department of Surgery, Tallaght Hospital for all his guidance and sharing of knowledge assisting me to complete this work. His input was much appreciated.

My thanks to Dr Pat Goodman, Department of Physics, Dublin Institute of Technology for the guidance and direction he has given me while completing this thesis. I am gratefully indebted for all his helpful comments.

Finally I would like to express my profound thanks to my husband Austin and extend this to our four children Emma, Thomas, Leah and Shane for their patience and encouragement and for all the times (accompanied by cups of tea and chocolate) that they allowed me to retreat to work on this thesis. Their continuous support was invaluable.

This thesis would not have been possible without you all.

Thank you.

Abbreviations

tcpO ₂	Transcutaneous Oximetry
TBI's	Toe/Brachial Indices
IDF	International Diabetes Federation
PAD	Peripheral Arterial Disease
ABI's	Ankle Brachial Indices
CIA	Common Iliac Artery
EIA	External Iliac Artery
IIA	Internal Iliac Artery
CFA	Common Femoral Artery
PFA	Profunda Femoris Artery
SFA	Superficial Femoral Artery
PA	Popliteal Artery
ATA	Anterior Tibial Artery
TPT	Tibio Peroneal Trunk
PTA	Posterior Tibial Artery
PER	Peroneal Artery
O ₂	Oxygen
CO ₂	Carbon dioxide
Hz	Hertz
F _d	Doppler shift frequency
Θ	Angle of insonation
CW	Continuous wave
PW	Pulsed wave
PPG	Photoplethysmography
DFPC	Diabetic Foot Protection Clinic
OPD	Outpatients
ATP	Absolute toe pressure
TMA	Transmetatarsal amputation
BA	Brachial Artery
BKA	Below knee amputation
AKA	Above knee amputation

List of Figures

- Figure 2.1 Islets within the pancreas containing beta cells
- Figure 2.2 A & B Diabetic foot ulceration
- Figure 2.3 Normal versus a diseased artery
- Figure 3.1 Diagram of the skin
- Figure 3.2 Layers of the artery
- Figure 3.3 The iliac arteries
- Figure 3.4 The lower limb arteries
- Figure 3.5 The foot arteries
- Figure 3.6 The microcirculation in the foot
- Figure 4.1 A soundwave
- Figure 4.2 The Doppler effect
- Figure 4.3 The angle θ
- Figure 4.4 Image of CW pencil probe
- Figure 4.5 Image of PPG
- Figure 4.6 PPG waveform
- Figure 4.7 Clark-type electrode
- Figure 4.8 Image of $tcpO_2$ probe
- Figure 5.1 $tcpO_2$ machine
- Figure 5.2 Picture of $tcpO_2$ probe in situ
- Figure 5.3 Picture of TBI and PPG machine
- Figure 5.4 Picture of arm cuff in situ
- Figure 5.5 Picture of toe cuff and PPG in situ
- Figure 7.1 TBI and $tcpO_2$ scatter graph
- Figure 7.2 Summary of statistical analysis per quadrant
- Figure 8.1 Comparisons of risk factors in the ulcer V's non-ulcer tests
- Figure 8.2 Comparisons of ATP's: Healed V Non healed outcomes
- Figure 8.3 Comparisons of $tcpO_2$: Healed V Non healed outcomes
- Figure 8.4 Comparisons of $tcpO_2$: Healed V Non healed outcomes

List of Tables

Table 5.1 Test variables

Table 6.1 Analysis of smokers V's non-smokers

Table 6.2 Analysis of those medicating for hypertension V's those not medicating for hypertension

Table 6.3 Analysis of those on statin therapy V's those not on statin therapy

Table 6.4 Analysis of diabetics V's non-diabetics

Table 6.5 Summary of statistical analysis per risk factor

Table 7.1 Actual % outcomes per group

Table 7.2 Overall results population % outcomes

Table 7.3 Intervention/amputation numbers across all the groups

Table 8.1 $tcpO_2$ and ATP's in the ulcer and non-ulceration group

Table 8.2 $tcpO_2$ and ATP's in tests with ulceration in both the diabetic and non-diabetic group.

Table 8.3 $tcpO_2$ and ATP's in the type 1 versus type 2 diabetics

Table 8.4 Analysis of ATP's: Healed V's Non healed outcomes

Table 8.5 Analysis of $tcpO_2$: Healed V's Non healed outcomes

Table 8.6 Analysis of $tcpO_2$: Healed V's Non healed outcomes

Table 8.7 Analyses of healed Vs non healed test numbers

Table 8.8 Predictive values table
Table 8.9 Average measurements of diabetic ulceration pre and post intervention

Table 8.10 Amputation numbers

List of Flow Charts

Flow Chart 7: Tests with a TBI < 0.6

Flow Chart 8: Breakdown of tests

Chapter 1

Introduction

Introduction

The human foot is a highly complex structure and any problems it develops can result in a deterioration of a patient's overall health and hence quality of life. There are various diseases, both of the foot and within the body, that lead to foot problems. Ulceration is one such problem. Ulceration is where an area of skin, which for whatever reason, has broken down and one can see the underlying tissue. Often in many cases the skin heals quickly, but unfortunately there are some cases where certain disorders or physiological conditions can impede the body's normal healing process.

One particular metabolic disorder that can prevent a quick healing process is diabetes mellitus. Foot ulceration is more common in patients with diabetes because they can develop a number of complications which are discussed in chapter 2, section 2.0. These complications can lead to minor problems such as small cuts, blisters, bruises etc. going undetected which can very quickly become worse and develop into ulceration. The complexity of ulceration can be troublesome and doctors look to many disciplines such as dermatology, podiatry, endocrinology and vascular diagnostics when treating them in the hope of aiding a positive outcome.

Indeed there have been many advances in recent years in terms of both vascular surgery techniques and investigative techniques to evaluate lower limb perfusion. These are in a bid to help improve perfusion, where it is an obstacle to wound healing. Despite these advances there is still no one universally accepted test that can predict wound healing, as it is globally accepted that it is dependent on a number of factors both local and systemic. General consensus would be that it is unlikely that one test will ever achieve 100% accuracy. And so, with this in mind the aim of this thesis is to analyse the results of a new test introduced into our vascular laboratory service – Transcutaneous Oximetry ($tcpO_2$) and to determine if it aids the treatment of patients with active foot ulceration and whether it provides any additional or alternative diagnostic information which alters the outcome or treatment of foot ulceration? Any additional supports this new and non-invasive test can provide to assist in the decision making of treatment planning will be quantified. A total of 247 patients were audited from December 2012 – December 2015. These equated to 310 initial $tcpO_2$ tests with a corresponding TBI test. The cost associated with managing and treating a chronic foot ulceration places a

significant strain on the health service and one that is going to increase with the increasing number of diabetic diagnoses. Cases of diabetes have progressively increased worldwide and it has been noted that there has been a two fold increase in the numbers of adults with diabetes in recent years. (Danaei et al. 2011). With the combination of the excessive costs in treating diabetic foot ulceration, combined with the detrimental effects they have on the patients overall health status, it is becoming increasingly necessary to develop and implement new methods to predict wound healing in this patient cohort.

Chapter 2

Diabetes Mellitus and lower limb arterial disease

Background

2.0 Diabetes Mellitus – what is it?

Diabetes mellitus is a common but chronic condition which causes significant morbidity and mortality if it is not properly diagnosed and managed. It is defined as a group of metabolic disorders which are characterised by too much glucose in the blood, also called hyperglycaemia. The digestive tract breaks down carbohydrates – sugars and starches found in food – into glucose which is a form of sugar that enters the bloodstream. The hormone insulin (made in the pancreas) allows the body to then use that sugar by helping glucose to enter the cells where it can be absorbed and used for energy. The pancreas is located behind the stomach and contains clusters of cells called islets. It is the beta cells within these islets that make insulin and are responsible for its release into the blood.

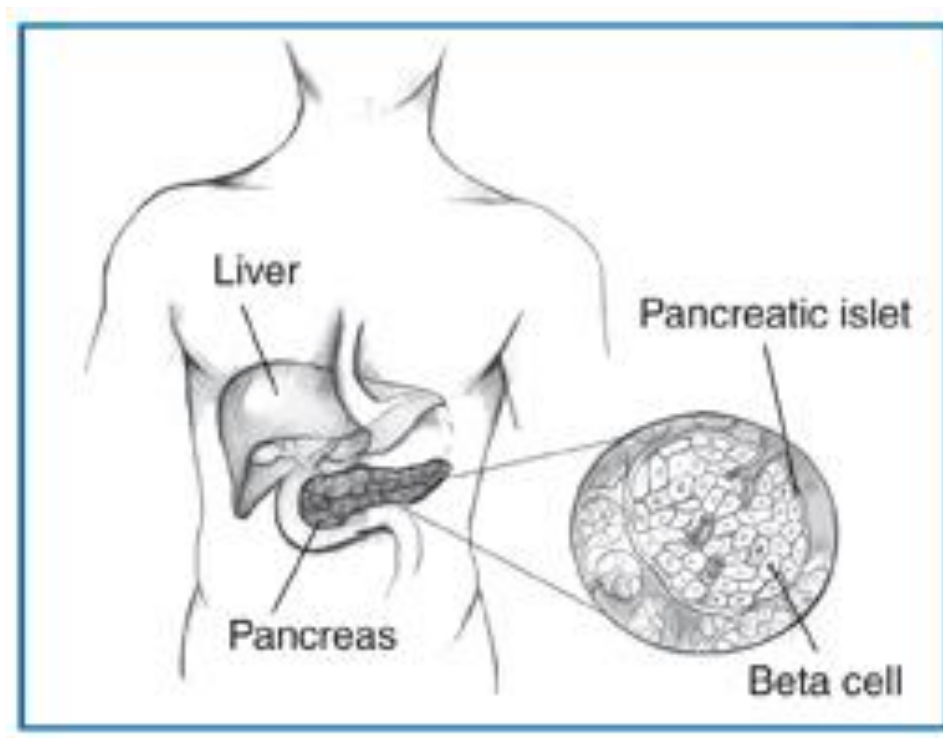

Figure 2.1 Islets within the pancreas containing beta cells

When a person has diabetes, either the pancreas fails to produce enough insulin or the body cannot properly use the insulin it has. As a result there is a build-up of glucose in the blood causing the cells to be starved of energy.

2.0.1 Types of diabetes

There are two types of diabetes:

Type 1:

Type 1 diabetes (previously known as insulin dependent, juvenile or childhood onset) is characterised by a lack or deficiency of insulin in the body (World Health Organization 1999). Normally the immune system protects the body from infection by identifying and destroying bacteria, viruses and other potentially harmful foreign substances. Type 1 diabetes occurs due to an autoimmune disease, where the body's immune system attacks and destroys its own cells, which in the case of Type 1 diabetes is the insulin producing beta cells in the pancreas. Treatment requires the daily administration of insulin (National Institute of Diabetes and Digestive and Kidney Diseases 2016). This type of diabetes occurs most frequently in children, with its cause not known or preventable to date. Symptoms include excessive urination, thirst, constant hunger, weight loss, vision changes and fatigue. Symptom onset may occur suddenly.

Type 2

Type 2 diabetes (previously known as non-insulin-dependent or adult onset) is the most common form of diabetes and is caused by a combination of factors which include insulin resistance. This is a condition in which the body's muscle, fat and liver cells do not use insulin effectively. It develops when the body can no longer produce enough insulin to compensate for the impaired ability to use insulin (National Institute of Diabetes and Digestive and Kidney Diseases 2016). It is largely the result of excess body weight and a lack of physical activity. This type is estimated to affect up to 95 percent of people with the condition. Symptoms may be similar to those of Type 1 diabetes but are often less marked (Irish Health 2003). This type of diabetes was most commonly diagnosed in patients aged 40 or older but it is starting to emerge in the population at a younger age (Chronic Conditions Hub 2016).

Gestational diabetes is hyperglycaemia with blood glucose values above normal but below those diagnostic of diabetes and occurs during pregnancy. Women with gestational diabetes are at an increased risk of complications during pregnancy and at delivery. This type of diabetes is diagnosed through prenatal screening (Diagnostic criteria and classification of hyperglycaemia first detected in pregnancy (World Health Organization 2013)).

2.0.2 Consequences of diabetes

Diabetes places a significant burden of care on the individual, the health care professionals and the wider health system (Zimmet et al. 2001). Individuals with it, over time, can develop problems with many parts of the body including the heart, the blood vessels, the eyes, the kidneys and even the nerves. The following is a list of the most common side effects:

- A combination of reduced blood flow and nerve damage (neuropathy, section 2.1) in the feet increases the chance of foot ulceration, infection and perhaps even lead to eventual amputation (Emerging Risk Factors et al. 2010).
- Adults with diabetes have a 2-3 fold increased risk of heart attacks and strokes (Emerging Risk Factors et al. 2010)
- Diabetic retinopathy is an important cause of blindness and occurs as a result of long term damage to the small blood vessels in the retina (Bourne et al. 2013).
- Diabetes is among the leading cause of renal failure (National Institute of Diabetes and Digestive and Kidney Diseases 2014).

2.0.3 Prevalence of diabetes

In Ireland, there is no diabetes register or surveillance programme and so estimates of prevalence vary. The Institute of Public Health have commissioned a number of reports in recent years looking at the prevalence of diabetes in Ireland. “Making Diabetes Count” 2005, “Making Diabetes Count 2007” and “Making Chronic Conditions count 2010 have all shown increasing rises in the number of diagnosed diabetics in the Republic of Ireland (Balanda et al. 2010, The Institute of Public Health 2006, The Institute of Public Health 2007). Prevalence of the disease has reached all estimated targets set out in these reports. It is important to also note, that there are numerous

people undiagnosed with the disease. According to the International Diabetes Federation (IDF) Diabetes Atlas, sixth edition, there are approx. 70,610 undiagnosed cases in Ireland (International Diabetes Federation 2015).

Diabetes Ireland estimate that during 2011 the number of people, of all age groups, with diabetes in Ireland (Type 1 and Type 2 populations combined) reached 191,000 (Diabetes Ireland 2016).

Currently Diabetes Ireland states that, the IDF Diabetes Atlas (2013) estimate that there are 207,490 people with diabetes in Ireland in the 20 – 79 age group (a prevalence of 6.5% in the population). This is in line with previous estimates that by 2020 there would be 233,000 people with the condition, and by 2030 there would be 278,850 people with the condition (a prevalence of 7.5% in the population) (International Diabetes Federation 2013) in Ireland.

Worldwide statistics say one in twelve of the world population have diabetes which equates to approx. 387 million people with a prevalence of 8.3%. This is expected to increase by 205 million by 2035. It is also suggested that one in two don't know they have diabetes and remain undiagnosed. Every six seconds one person dies from diabetes and there were 4.9 million deaths in 2014 directly attributed to the disease (International Diabetes Federation 2013).

2.0.4 Economic cost of diabetes

Diabetes can cause a variety of health complications for patients. It is responsible for many early deaths, reduced quality of life and significant costs to the health and social care system as well as the overall economy. The life expectancy of people with diabetes is shortened by up to 15 years, and 75% die of macrovascular complications (National Institute for Health Care Excellence 2016b).

It is estimated that 10% of all people with diabetes will have a diabetic foot ulcer at some point in their lives. Diabetes is the most common cause of non-traumatic limb amputation, with diabetic foot ulcers preceding more than 80% of amputations in people with diabetes. After a first amputation, people with diabetes are twice as likely to have a subsequent amputation as people without diabetes. Mortality rates after diabetic foot ulceration and amputation are high, with up to 70% of people dying within

5 years of having an amputation and around 50% dying within 5 years of developing a diabetic foot ulcer (National Institute for Health Care Excellence 2016b).

The budget for the Irish health service in 2014 was €12.774 billion. For 2015 there was an increase of Exchequer funding of €305 million, bringing the budget up to €13.079 billion (Department of Health 2014). It is estimated that approx. In Ireland 10% of the total health budget is spent on diabetes - approx. €1.27 billion with a further estimate of 60% of this being spent annually on complications which includes foot ulcers (Nolan et al. 2006). The increasing economic burden of diabetes on our health care system is becoming a major challenge for the government.

2.1 Diabetes and the foot

Foot ulcers can be complex and difficult to manage. The ever increasing diabetic group are the most complex and difficult patient cohort to manage when it comes to wounds and ulceration.

Patients with diabetes run an increased risk of developing foot problems largely because of either diabetic neuropathy or narrowing of the arteries called peripheral arterial disease (PAD).

PAD leads to a reduction in perfusion to the foot which in turn often leads to skin breakdown – see arterial ulceration, section 2.2. PAD affects 1 in 3 people with diabetes over the age of 50 (National Institute for Health Care Excellence 2016b).

In patients with diabetes, they can often have a higher than normal blood sugar level so that over time nerves can become damaged (National Institute of Diabetes and Digestive and Kidney Diseases 2013). The increased blood sugar interferes with the ability of the nerves to transmit signals. Diabetes also weakens the walls of the small blood vessels (capillaries) that supply the nerves with oxygen and nutrients. This damage leads to a loss of sensation in the peripheries (hands and feet), and an inability to feel pain which is called peripheral or diabetic neuropathy. Peripheral neuropathy can also cause muscle weakness and hence a loss of reflexes, especially at the ankle, which can lead to changes in the way a patient walks. Foot deformities are common.

Some patients have mild symptoms but for others they can be disabling and even fatal. Often symptoms develop gradually, and the patient may not notice problems until considerable damage has occurred. What can start out as a small cut, if it goes unnoticed, can eventually end up becoming severely infected. The risk of infection is high in this patient group, and if it develops to affect the bone, it can lead to tissue death (gangrene). In this case ulcers become impossible to treat and require amputation of a toe, foot or even the lower leg. From the above, it is easy to understand why people with diabetes are more prone to foot ulcers than other patient groups. Early detection of foot and skin sores is vital to help prevent infection and progression into full blown ulceration.

2.2 Ulceration

The skin is tough, pliable and resistant to injury. In the case of it becoming injured or broken, it is generally very resilient and has an amazing ability to self-repair and heal. Despite this resiliency, the skin is unfortunately susceptible to breakdown if subjected to prolonged abuses such as excessive pressure, shear force, friction or moisture. Skin breakdown ranges from minor scrapes, cuts, tears, blisters or burns to the most serious pressure ulcers, with the destruction of tissue down to and even including the bone. Ulcers are wounds, open sores or simply a break in the skin that allow air and bacteria to get into the underlying tissue. They are a direct result of damage or destruction of the epidermis or dermis which can allow infection to manifest. This in turn can often lead to the wound not healing or for the wound to keep returning frequently.



A

B

Figure 2.2 A & B Diabetic foot ulceration

In most people, small wounds or injuries heal up quickly and without any difficulty within a week or two. If there is an underlying problem, the skin does not heal and the area of breakdown can actually increase in size. This then becomes a chronic ulcer. There are many contributing factors for ulcer development including poor nutrition and hydration, weight, impaired circulation and oxygenation, substance abuse, depression, and age. Smoking, diabetes and other vascular conditions can lead to decreased circulation which increases the risk for skin breakdown. Diabetes is a leading underlying contributory factor. Chronic and non-healing wounds are problematic not only for the patient but also for the health care system. They can often lead to long hospitalisation periods due to slow healing. The complex diabetic patient group, with

their many risk factors affecting their ability to heal ulcers, can lead to a very lengthy and also very costly process for both the patient and health service. Research and health initiatives have been developing around foot protection and specifically in the prevention of problems rather than the treatment of them.

One of the most important issues when it comes to ulcers is determining the cause and then ensuring the area is receiving enough nutrients to encourage and promote healing. Arterial disease accounts for approx. 15% of all leg ulcers with the remaining causes being venous disease (approx. 80%) with other causes such as diabetes, rheumatoid arthritis, malignancies and lymphoedema accounting for approx. 5% (Circulation Foundation 2016). In some cases two or more conditions can be attributed to the cause of the ulcer and hence to treat effectively it is important to diagnose at an early stage the type of ulcer present. Arterial ulceration and diabetes go hand in hand and so will be further discussed.

2.2.1 Atherosclerosis and arterial ulcers:

Atherosclerosis is a systemic disease which affects the arteries. Fatty deposits called atheroma build up on the inside lining of the arteries which reduces the lumen of a vessel thus reducing the blood flow through the vessel.

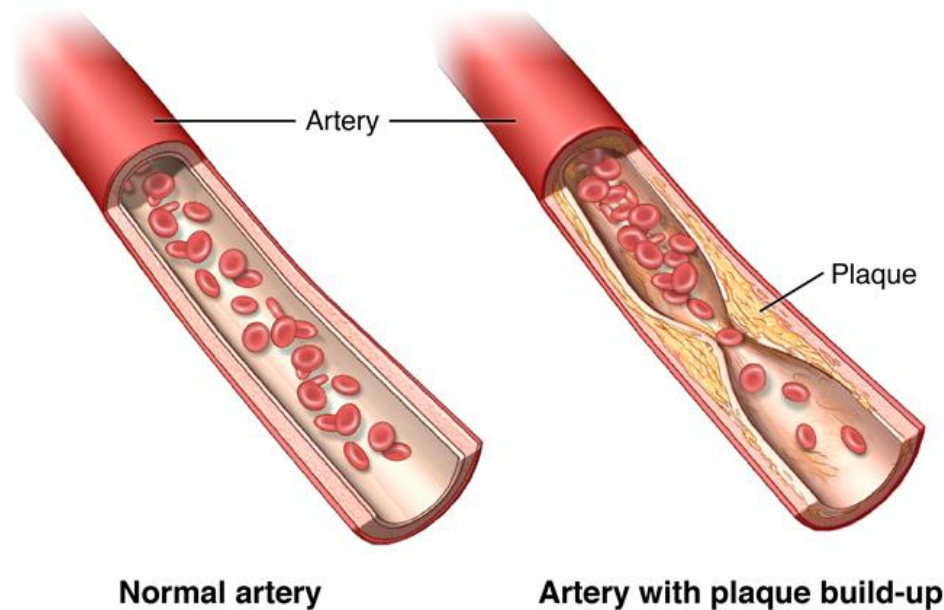

Figure 2.3 Normal versus a diseased artery

A reduction in blood flow to various parts, in turn leads to a decreased oxygen supply to the tissue being supplied by that vessel. Arteries in the legs are commonly affected which in turn leads to poor perfusion of the feet.

What causes atherosclerosis? The most commonly recognised risk factors in the development of atherosclerosis are smoking, diabetes, hypertension, hypercholesterolemia, lack of physical activity, family history, obesity and gender (National Institute of Health 2016).

The restriction of blood flow to the legs and feet due to the build-up of atheroma on the arteries is called peripheral arterial disease (PAD). PAD can vary from mild to severe and it is important to assess prior to treating any patients presenting with ulceration. Patients with ulceration who have been diagnosed with severe PAD or critical lower limb ischaemia may progress to major limb loss unless successful surgical intervention

occurs. Blood pressure measurements are used to produce an index which indicates a percentage of blood flow to the area being examined. The baseline tests for patients suffering with PAD and/or ulceration is Ankle Brachial Indices (ABI's) or Toe Brachial Indices (TBI's). TBI's are the standard test of choice in the diabetic patient group. Often in the diabetic patient group the tibial vessels are affected by calcification causing them to be falsely elevated or incompressible and so TBI's are deemed to be more reliable as a marker of perfusion. This test is detailed in chapter 5, section 5.3.2.

Work done by others has shown that in the diabetic patient group the risk of atherosclerotic disease is markedly increased. It is also noted that it can develop at an earlier age, be more severe and more diffuse making it very difficult to treat successfully (Marso S. P. Hiatt W. R. 2006).

The measurement of TBI's is a reproducible and quantitative test to assess arterial blood flow to the lower extremities. It is non-invasive and can diagnose the presence of PAD and determine its severity.

Chapter 3

Lower limb arterial anatomy

Anatomy

3.1 Anatomy of the human skin

The skin is a vital organ that covers the entire outside of the body making it the body's largest organ. It receives one third of the body's blood circulation. It is comprised of two layers that cover a third fatty layer. These three layers differ in their function, thickness, and strength. The outer layer is called the epidermis - it is a tough protective layer that contains the melanin-producing melanocytes. The second layer (located under the epidermis) is called the dermis - it contains nerve endings, sweat glands, oil glands, and hair follicles. Under these two skin layers is the fatty layer of subcutaneous tissue, known as the subcutis or the hypodermis.

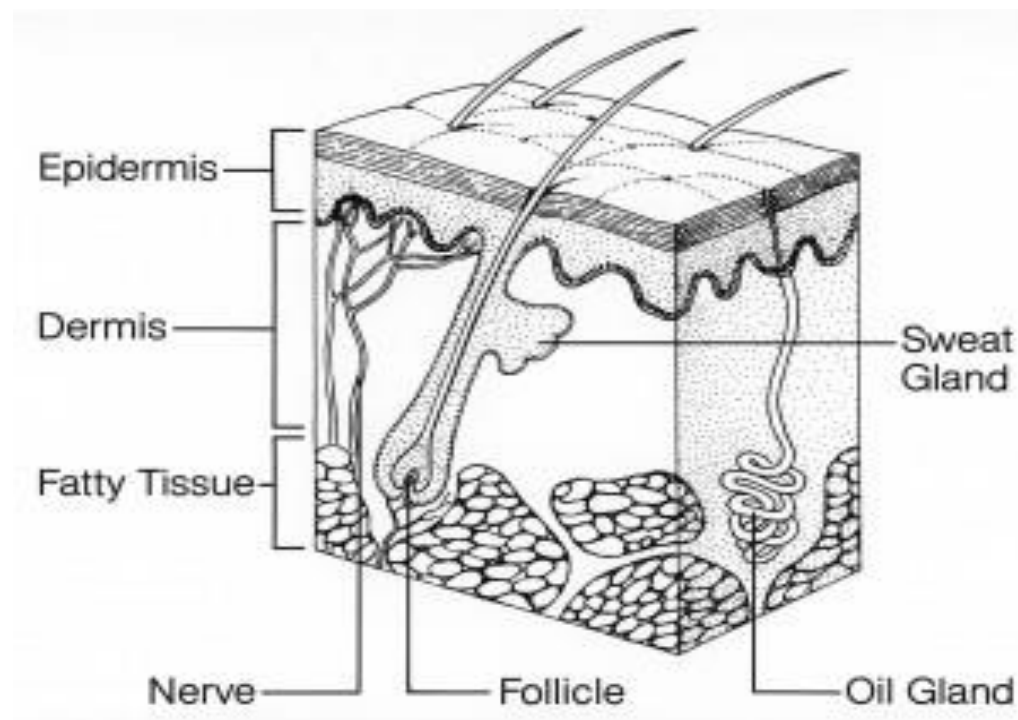

Figure 3.1 Diagram of the skin

1) The Epidermis

This is the outermost layer of the skin. The thickness of the epidermis varies in different types or location of skin. Its role is to form a protective barrier against pathogens and various injuries that could occur due to the environment. It shields the body against heat, light, injury, and infection. It also helps regulate body temperature, gathers sensory information from the environment, stores water, fat, and vitamin D, and plays a role in the immune system protecting us from disease.

The epidermis itself is made up of five sub-layers that work together to continually rebuild the surface of the skin.

The five sub-layers are as follows:

i) The Basal Cell Layer

This contains small round cells called basal cells which continually divide, with new cells constantly pushing older ones up towards the surface of the skin, where they are eventually shed. The basal cell layer contains cells called melanocytes which give the skin its colouring or pigment known as melanin. These also protect the deeper layers of the skin from the harmful effects of the sun.

ii) The Squamous Cell Layer

This is located above the basal layer. The basal cells that have been pushed upward, are maturing and become known as keratinocytes. These produce keratin, which is a tough, protective protein that makes up the majority of the structure of the skin, hair, and nails. This is the thickest layer of the epidermis.

iii & iv) The Stratum Granulosum & the Stratum Lucidum

The keratinocytes from the squamous layer are then pushed up through these two thin layers. As these cells move further towards the surface of the skin, they get bigger and flatter and adhere together, and then eventually become dehydrated and die. This process results in the cells fusing together into layers of tough, durable material, which continue to migrate up to the surface of the skin.

v) **The Stratum Corneum**

This is the outermost layer of the epidermis, and is made up of 10 to 30 thin layers of continually shedding, dead keratinocytes. As the outermost cells age and wear down, they are replaced by new layers of strong, long-wearing cells.

2) **The Dermis**

The dermis is located beneath the epidermis and is the thickest of the three layers of the skin and makes up approximately 90 percent of the thickness of the skin. Its main function is to regulate temperature and to supply the epidermis with nutrient-saturated blood. The dermis layer is made up of two sub-layers. One is called the Papillary Layer which supplies nutrients to the epidermis and regulates temperature and the other is the Reticular Layer which strengthens the skin, to provide structure and elasticity.

Much of the body's water supply is stored within the dermis. This layer contains most of the skins specialised cells and structures, including:

- **Blood vessels** which supply nutrients and oxygen to the skin and take away cell waste and cell products
- **Lymph cells** or capillaries are a network of tiny walled vessels which pick up fluid that leaks into the tissue from the blood stream and which is returned back to the circulatory system.
- **Hair follicles** are a tube-shaped sheath that surrounds the part of the hair that is under the skin and nourishes the hair
- **Sweat glands** which in the armpits and pubic region secrete a milky sweat that encourages the growth of the bacteria responsible for body odour. Other glands over the body regulate body temperature by bringing water via the pores to the surface of the skin, where it evaporates and reduces skin temperature.
- **Sebaceous glands** secrete oil that helps keep the skin smooth and also helps keep skin waterproof and protects against an overgrowth of bacteria and fungi on the skin.
- **Nerve endings** are pain and touch receptors that transmit sensations of pain, itch, pressure and information regarding temperature to the brain for interpretation

- **Collagen** is a protein made by fibroblasts that is found throughout the body in the connective tissues that hold muscles and organs in place.
- **Elastin**, a similar protein that allows the skin to spring back into place when stretched and keeps the skin flexible.

3) **The Subcutis**

This is the innermost layer of the skin. It consists of a network of fat and collagen cells. It functions as both an insulator, conserving the body's heat and as a shock-absorber, protecting the inner organs. It also stores fat as an energy reserve for the body. The blood vessels, nerves, lymph vessels, and hair follicles also cross through this layer.

3.2 The Macrocirculation

The macrocirculation is the circulation of blood through the larger vessels in the body - arteries and veins. The following section will detail the anatomy of the lower limb arteries.

3.2.1 Anatomy of arteries

Arteries are blood vessels within the body whose main function is to deliver oxygen-rich blood from the heart to the various organs and tissues of the body. Arteries, despite their location in the body, have a similar structure. Each artery is a muscular tube lined by smooth tissue with three distinct layers:

- The intima

The intima is the inner layer which is lined by a smooth tissue called endothelium. This is composed of a thin layer of endothelial cells and lines the entire circulatory system from your heart to the large arteries, right all the way down to the very tiny capillary beds.

- The media

The media is composed of a smooth layer of muscle fibres surrounded by fibrous tissue which allows the arteries withstand the high pressures from the heart. This muscular layer permits the arteries to constrict and dilate to adjust the volume of blood needed by the tissues that they feed.

- The adventitia

The adventitia is the outermost layer and it is used to attach the vessel to the surrounding tissue. This layer is composed of connective tissue with varying amounts of elastic and collagenous fibres

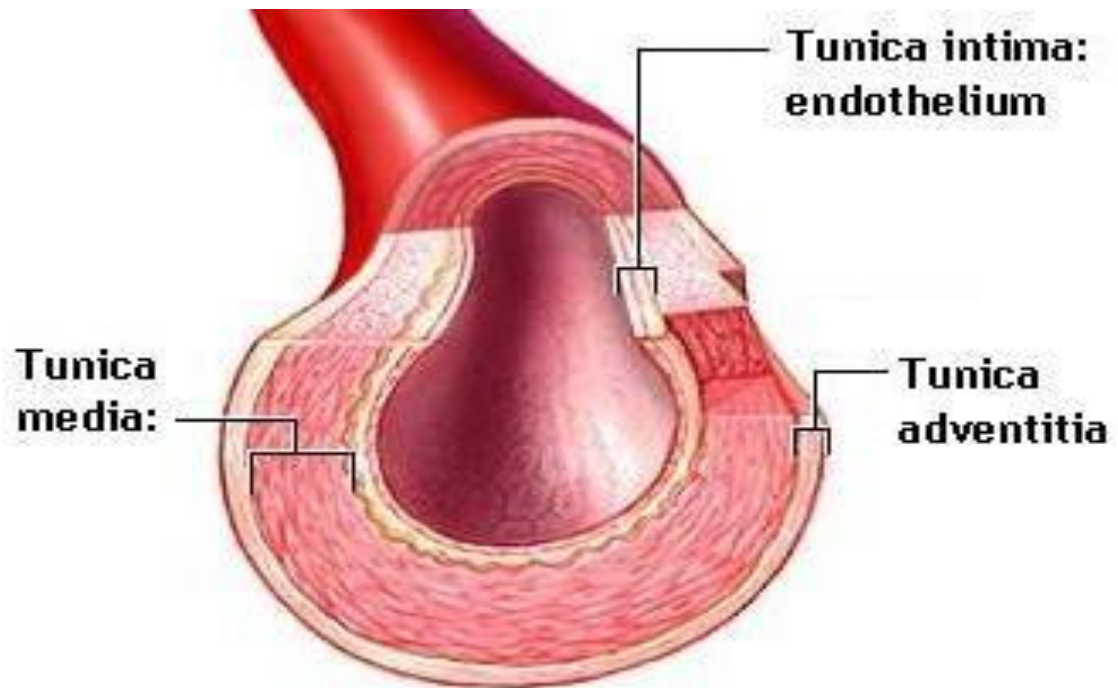

Figure 3.2 Layers of the artery

3.2.2 The lower limb arterial anatomy

The largest artery in the body is the aorta. It is connected to the heart's left ventricle and it carries oxygenated blood around the body. It has many branches which feed all the various abdominal organs. At L4 or the level of the umbilicus, the aorta divides into two main branches – these are called the common iliac arteries (CIA). At the brim of the pelvis the CIA further branches into the internal (IIA) and external iliac arteries (EIA). The IIA supplies the pelvis muscles. The EIA descends to groin level and becomes the common femoral artery (CFA). See figure 3.3 below.

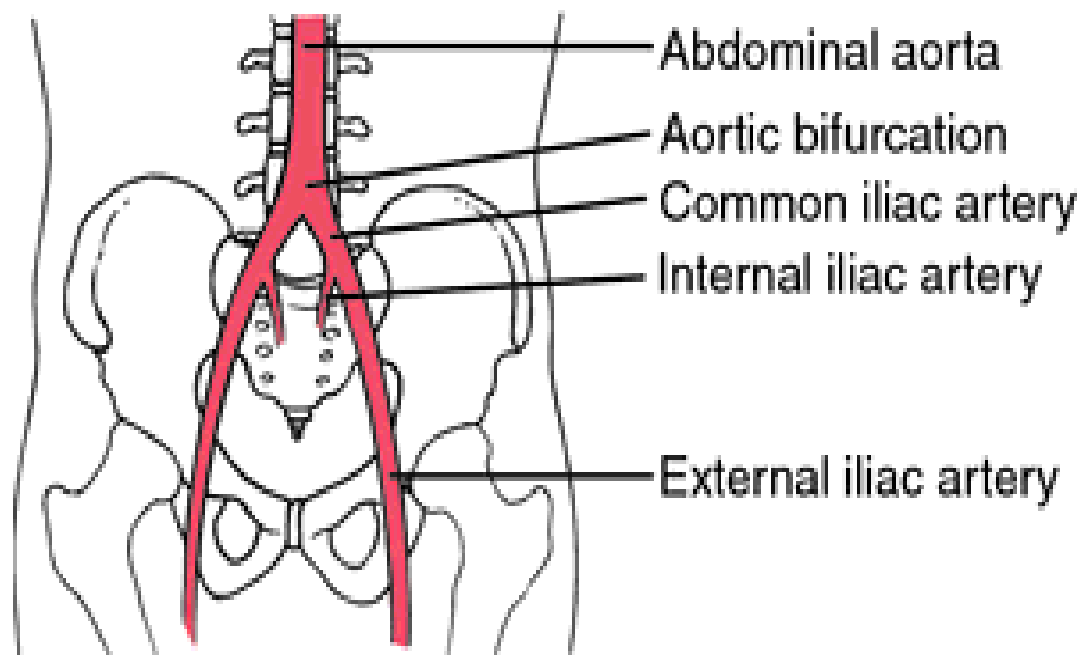

Figure 3.3 The iliac arteries

The CFA just below groin level divides to become the profunda femoris (PFA) and the superficial femoral artery (SFA). The PFA supplies the thigh muscles. The SFA continues to knee level and becomes the popliteal artery (PA). Just below knee crease level, the anterior tibial artery (ATA) arises off the PA and this vessel runs on the lateral aspect of the calf to ankle level where it continues into the foot as the dorsalis pedis artery (DPA). The PA continues after the ATA take off as the tibioperoneal trunk (TPT). The TPT divides into the posterior tibial artery (PTA) and the peroneal artery (PER). See figure 3.4 below.

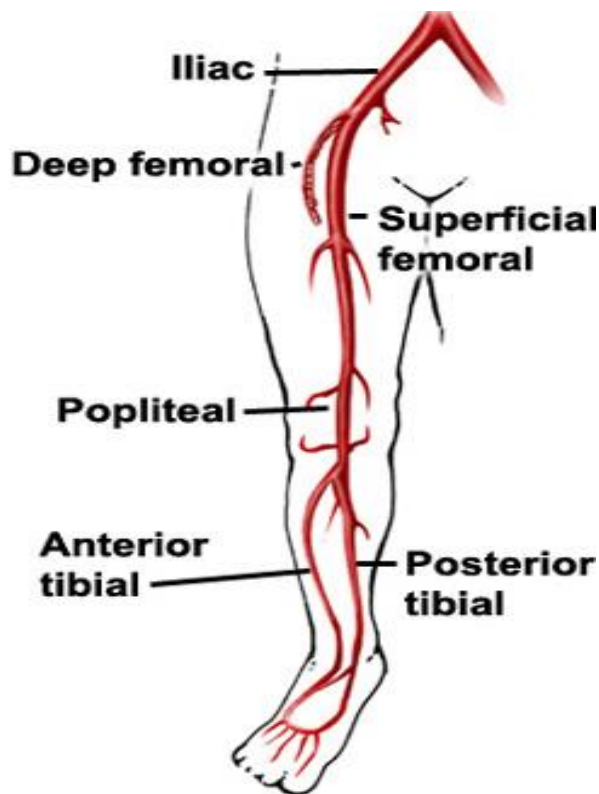

Figure 3.4 The lower limb arteries

The PTA supplies blood to the posterior calf muscles and plantar surface of the foot. It gives rise to the medial and lateral plantar arteries. The PER supplies blood to the calf and ankle muscles. It divides on the lateral aspect of the foot and forms the external malleolus artery, lateral tarsal artery and external plantar artery. The plantar arteries, lateral, medial and deep form a looping web across the foot and down through each toe.

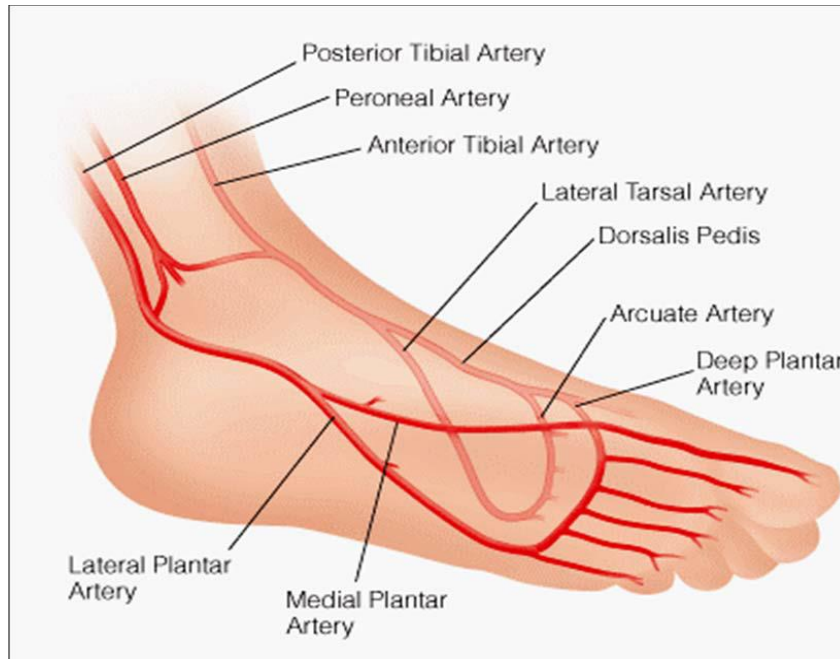

Figure 3.5 The foot arteries

3.3 The Microcirculation

Blood circulates from the heart to the arteries, to arterioles (small arteries), to capillaries, to venules (small veins), to veins and back to the heart. The microcirculation is the circulation of the blood in the smallest blood vessels, the main function of which is to deliver oxygen (O₂) and nutrients and to remove carbon dioxide (CO₂). Essentially it is responsible for the regulation of tissue perfusion. It also serves to regulate blood flow and tissue perfusion which can affect blood pressure and the body's responses to inflammation such as oedema.

It is composed of terminal arterioles, capillaries, and venules that drain capillary blood.

Arterioles: These are the vessels on the arterial side of the microcirculation. They are surrounded by smooth muscle cells and measure approx. 10-100µm in diameter. They contract and relax their diameter in response to a diverse range of stimuli, which means blood flow in the microcirculation remains constant despite changes in systemic blood pressure. They are responsible for carrying the blood to the capillaries.

Capillaries: These have no smooth muscle cells and measure between 5-8µm in diameter. Approximately 7% of the body's blood is in the capillaries and this is where the exchange of substances occurs. Precapillary sphincters control the flow of blood between the arterioles and the capillaries. The displacement of materials between the interstitial fluid and the blood is called the capillary exchange. The precapillary sphincters contain muscle fibres allowing them to contract. If the sphincters are open blood can flow freely to the capillary bed which is where fluids, gasses, nutrients and wastes are exchanged between the blood and the body cells. If the sphincters are closed blood cannot flow through the capillary bed and must flow directly from the arteriole to the venule.

Venules: Blood then flows out of the capillaries and into the venules, which have a little smooth muscle and are approx. 10-200µm in diameter. The blood flows from the venules into the veins. In addition to these blood vessels, the microcirculation also includes lymphatic capillaries and collecting ducts.

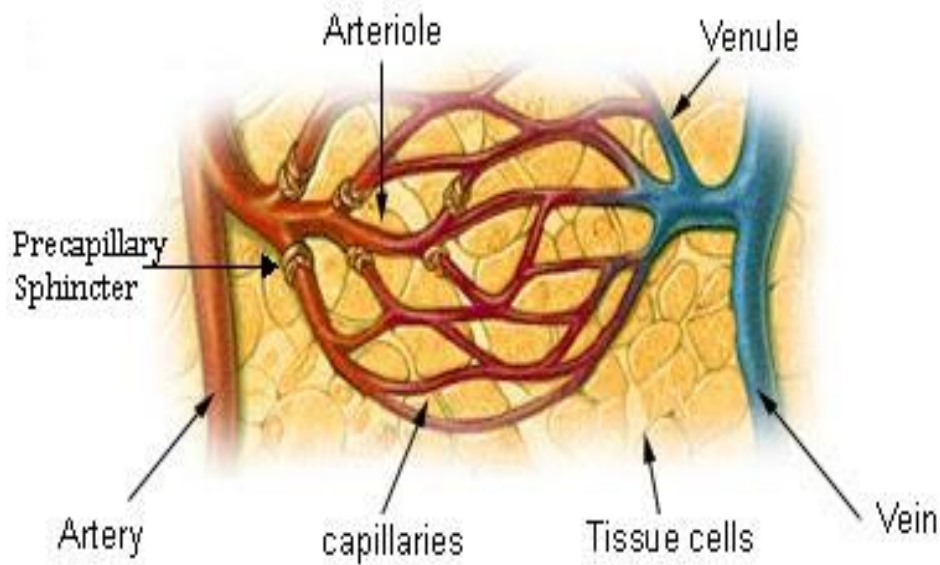

Figure 3.6 The microcirculation in the foot

Blood is supplied to all parts of the body at all times but all capillary beds do not contain blood at all times. Blood is diverted to the various parts of the body that require it most, at a particular time.

One of the most important issues when it comes to ulcers is firstly determining the cause and then ensuring that the area is receiving enough nutrients to encourage and promote healing.

Transcutaneous oximetry ($tcpO_2$) is considered the gold standard for assessment of tissue oxygenation, an essential test in assessing the probability of wound healing (Lee Y.N. et al. 2014). $tcpO_2$ is a local non-invasive measurement reflecting the amount of O_2 that has diffused from the capillaries through the epidermis to a Clark-type electrode at the measuring site. It provides instant continuous information about the body's ability to deliver oxygen to the tissue and thereby measures nutritive blood perfusion at a given site. With the current emphasis on cost savings in the health service, this non-invasive test is gaining importance as a tool for predicting healing. Physicians use this data to aid decision making with regards to treatment plans for their patients. In being able to determine the tissue oxygenation status of a wound area, the physician can out rule any treatment options which would be ineffective and move directly for the quickest most efficacious treatment. The microcirculation is important to consider in the diabetic

patient group especially in the cases where traditional tests such as TBI's aren't possible due to ulceration or previous amputation.

Chapter 4

Physics and Instrumentation

4.0 Physics

The following chapter looks at the physics behind ultrasound and the basic principles used in measuring the flow or velocity of flow in the lower extremities.

4.0.1 Soundwaves

Soundwaves are described as mechanical vibrations of particles or molecules within a medium. The vibration of one particle transmits a corresponding vibration to an adjacent particle and so a wave is passed through a medium. The transmission of a soundwave through a medium occurs at a fixed speed which is determined by the elasticity and density of a particular medium. Frequency or pitch is described as the rate at which an individual particle vibrates. This is measured in Hertz (Hz) and is the number of cycles per second.

Ultrasound is defined as sound which has a frequency above the audible range of humans which is greater than 20 kHz.

Soundwaves have a longitudinal, sinusoidal waveform which varies from high pressures (compression) to low pressure (rarefaction). Wavelength is the distance between identical points in a cycle.

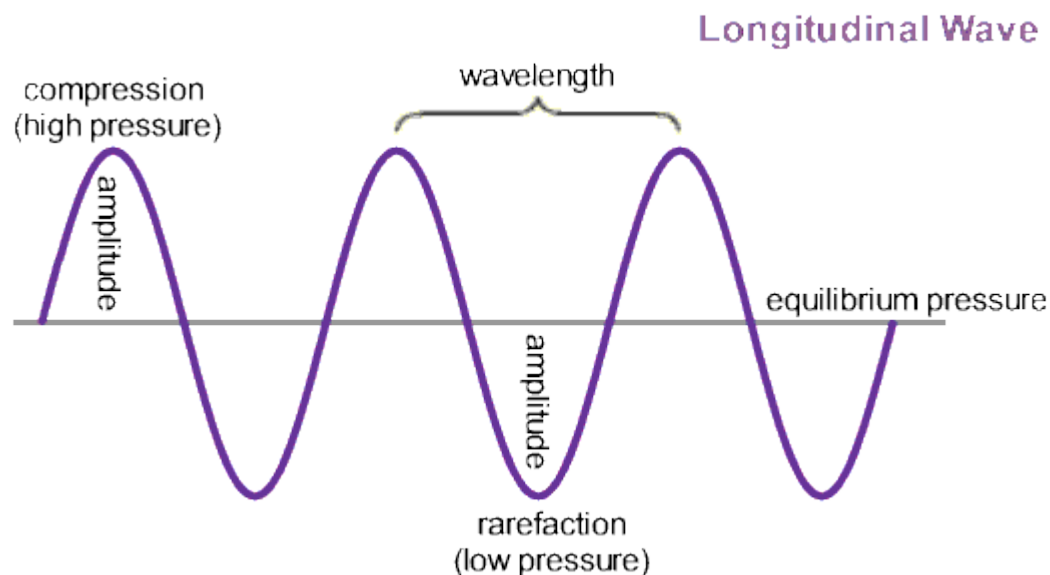
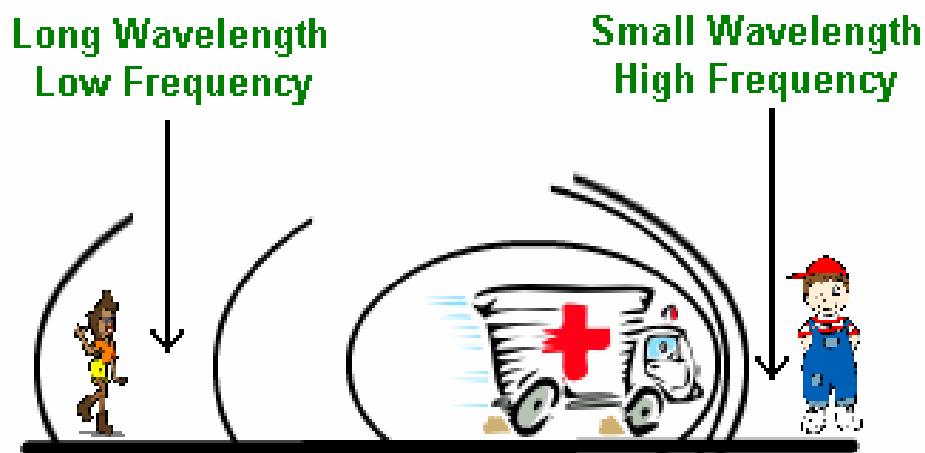

Figure 4.1 A Soundwave

4.0.2 The Doppler Effect

The Doppler Effect was first described by an Austrian physicist, Christian Andreas Doppler in 1842. It is described as a shift in the observed frequency of a radiated wave motion when there is movement between the source of the radiation and the observer. The classic example is an ambulance siren. This sounds higher pitched when it is travelling towards you and lower pitched when travelling away.



The Doppler Effect for a Moving Sound Source

Figure 4.2 The Doppler Effect

If the source and the observer are both stationary, then emitted waves travel through the intervening medium at a constant and regular rate, and pass the observer at the same rate as transmitted. If the source is moving towards a stationary observer, the wavelength becomes shorter as the source gets closer, and even though they pass the observer at the same speed, the observer experiences a higher frequency. Conversely if the source is moving away from the observer, the wavelength is increased and the observer experiences a lower frequency.

If the observer is moving towards a stationary source, the observer intercepts the waves at a faster rate, and experiences a higher frequency. Conversely if the observer is moving away from a stationary source, they intercept the waves at a slower rate, and experience a lower frequency.

In the case of both a moving source and a moving observer, the difference between both the transmitted and received frequencies of the waveforms is called the Doppler Shift.

This can be positive or negative depending on whether the blood flow is going towards the transducer or away from it.

In vascular ultrasound the Doppler shift frequency provides the basis for calculating the velocity of flow in the vessel under investigation. It falls within the audible hearing range of the human ear and so the pitch can be heard by the physiologist. The method of applying the Doppler principle in ultrasound differs from the original theory in that the moving targets are blood cells, so that the transducer is both the source and the receiver. The reflected or scattered waveform and the corresponding change in frequency can be observed with the difference between the transmitted and received frequencies being referred to as the Doppler shift frequency (f_d).

Equation 4.1

The Doppler shift frequency

$$F_d = \frac{2f_t V \cos \theta}{C}$$

f_t = the frequency emitted by the transducer

θ = the angle between the Doppler beam and the direction of flow

C = velocity of sound in the medium – approx. the same in all soft tissue (1540 m s^{-1})

V = the blood cell velocity

The angle of insonation (θ) is very important in the clinical use of Doppler. If $\theta = 0^\circ$, $\cos \theta = 1$ and the maximum Doppler shift frequency is obtained for a given velocity. As θ increases the value of $\cos \theta$ decreases and hence the Doppler shift frequency decreases until at $\theta = 90^\circ$ ($\cos \theta = 0$) and there is no Doppler shift at all and no audible signal. To obtain reliable quantitative Doppler data in clinical practice, θ should not exceed 60° . (The Society for Vascular Technology of Great Britain & Ireland 2001).

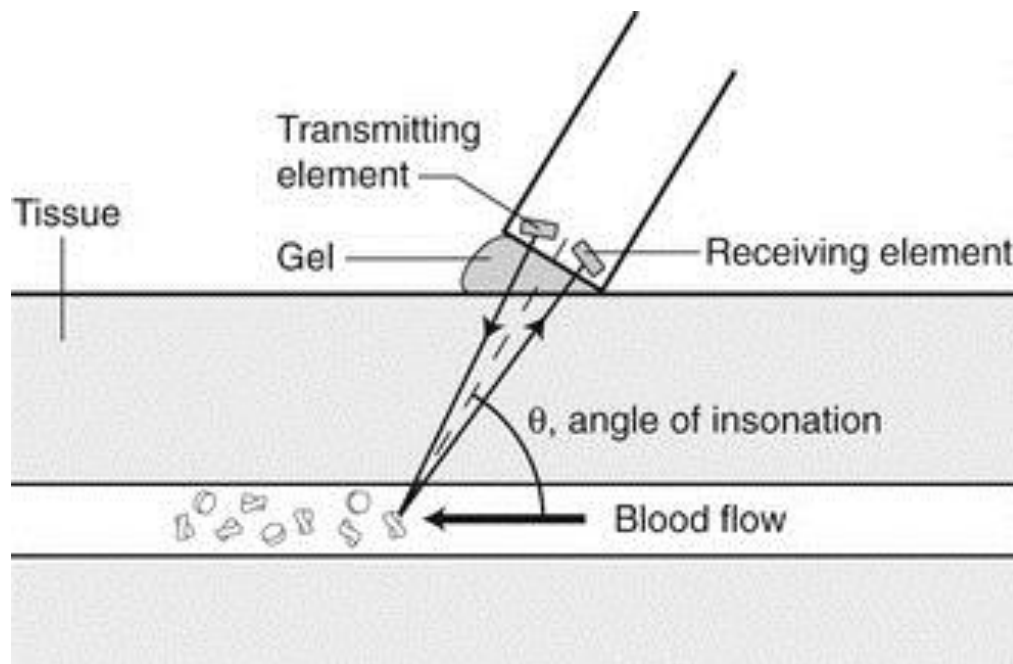

Figure 4.3 The Angle θ

The use of Doppler in clinical investigations was not accomplished until the 1960's with the development of the first Doppler probe by Satomura in 1959 (Coman I.M. Popescu B.A. 2015).

Currently Doppler ultrasound is routinely used as a non-invasive test to examine and evaluate the movement of blood flow through arteries and veins. It enables medical staff to diagnose multiple conditions such as arterial narrowing, deep vein thrombosis, heart and numerous organ defects.

4.1 Instrumentation

This section will discuss the actual equipment used in practice to assess perfusion, both with regards to actual blood flow and also oxygenation of tissue.

4.1.1 Doppler Instruments

In clinical practice there are two types of Doppler instrumentation – continuous wave (CW) and pulsed wave (PW). These can also be described as either imaging or non-imaging. Non-imaging techniques (CW) include the traditional hand held continuous wave Doppler units used in the detection of peripheral pulses. These are used when performing Ankle Brachial Indices (ABI's) or when recording the Brachial systolic pressure for a set of TBI's. Imaging techniques include colour Doppler, power Doppler and spectral pulsed wave Doppler and are always used in conjunction with B-Mode imaging used in general ultrasound.

Continuous Wave Doppler are the simplest Doppler devices available and are typically a hand held unit with a pencil probe attached.



Figure 4.4 Image of CW pencil probe

The pencil probe transducer consists of two piezoelectric elements or crystals mounted on the end. One crystal acts as the emitter and the other one as the receiver. The two

crystals are set at angles to each other so that the emitted and received beams overlap or converge to form a long narrow crossover region. This is where the Doppler signal can be detected. The detected signal is obtained from all the moving targets passing through this region. Continuous wave devices are widely used today and have many clinical applications such as foetal heart monitoring and the detection of peripheral pulses. However, their main disadvantage is that any sound detected in the crossover region can be heard by the operator. For example flow from more than one vessel may be heard at the same time such as an artery and a vein, resulting in a mixed arterial and venous signal being detected. The biggest advantage is that they are inexpensive and easy to use by a skilled operator.

4.1.2 Photo Plethysmography (PPG)

Photoelectric plethysmography is used to obtain the systolic pressures at the toe when performing a TBI exam. The sensor of the PPG contains an infrared light which has an emitting diode and a phototransistor. When this sensor is placed on the limb, the infrared light is transmitted into the superficial layers of the skin and the reflected portion is received by the phototransistor.



Figure 4.5 Image of PPG

The resulting signal is proportional to the quantity of red blood cells in the cutaneous circulation i.e. it measures changes in light absorption (Zwiebel W.J. and Pellerito J. 2000).

A conventional pulse oximeter monitors the perfusion of blood to the dermis and subcutaneous tissue of the skin. PPG is a low cost and simple technique used to detect blood volume changes. It is non-invasive and in recent years there has been a resurgence of interest in the technique and its applications in a clinical setting.

The PPG waveform comprises a pulsatile waveform superimposed on a slowly varying baseline with various lower frequency components. The pulsatile one is attributed to

cardiac changes in the blood volume with each heartbeat, and the second one is attributed to respiration, sympathetic nervous system activity and thermoregulation. The below diagram figure 4.6 shows a typical PPG signal without motion artefact.

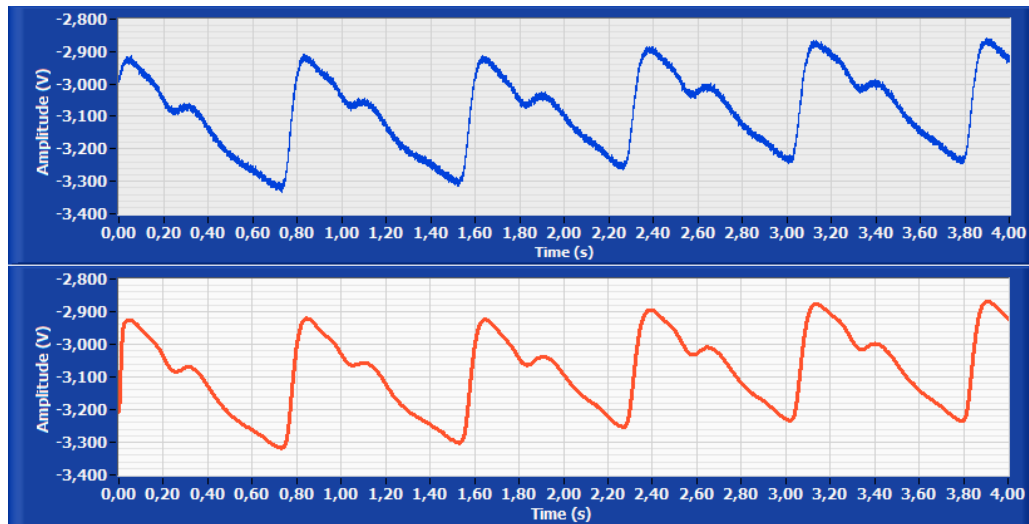

Figure 4.6 PPG Waveform

PPG technology is being used in a wide range of commercially available medical devices for measuring oxygen saturation, blood pressure and arterial stiffness, cardiac output, assessing autonomic function and detecting peripheral vascular diseases (Allen J. 2007). For our purposes we use it for measuring blood perfusion in the toes.

4.1.3 The Clark Electrode

Lealand C Clark is responsible for the development of this electrode and it is used to quantify or measure oxygenation tension at a particular point on the skin. In the field of vascular diagnostics it is used in the $tcpO_2$ test. A transcutaneous oximeter uses a Clark polarographic electrode which is modified to contain both a heating element and a thermistor.

The heating element maintains a pre-set temperature of $42 - 45^\circ\text{C}$.

The role of the thermistor is to continuously monitor this.

A phosphate buffer and a potassium chloride solution is contained between the electrode surface and an oxygen permeable membrane.

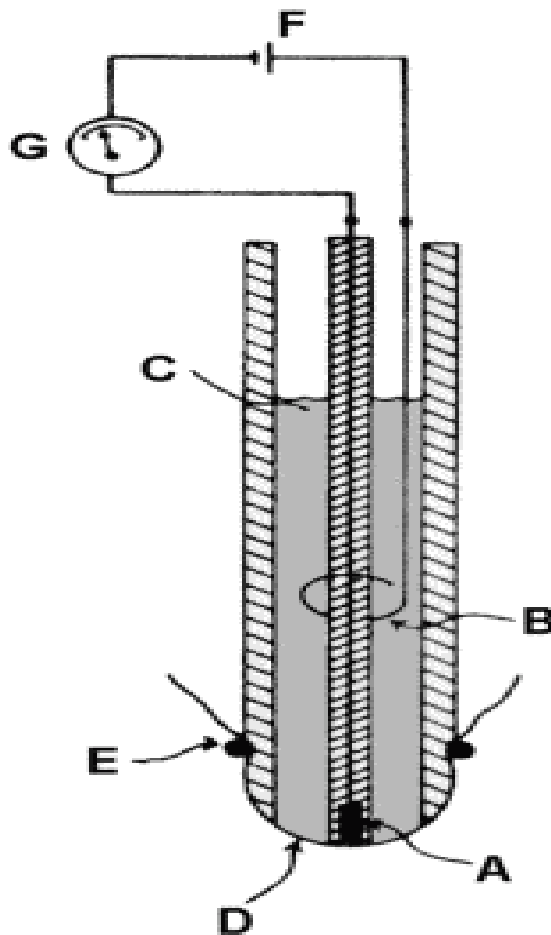

Figure 4.7 Clark-type electrode

(A) Pt- (B) Ag/AgCl-electrode (C) KCl electrolyte (D) Teflon membrane (E) rubber ring (F) voltage supply (G) galvanometer

The electrode is attached to the skin by an adhesive fixation ring which is then filled with the contact solution. This maintains a continuous liquid pathway for the oxygen to diffuse from the skin to the electrode. A constant polarizing voltage is applied to the cathode within the sensor. The polarized oxygen electrode provides electrons to reduce molecular oxygen as it arrives at the electrode surface. Separate to the polarizing voltage an extra current is derived from the reduction of oxygen at the electrode surface as the oxygen is converted to hydroxyl ion. The current generated is directly proportional to the number of oxygen molecules in the solution. Hence the oxygen sensor can be used to determine the oxygen tension in the skin capillaries.



Figure 4.8 Image of tcpO₂ probe

This chapter outlined the basic physics principles and the practical application of both the ultrasound and oximetry modalities. The next section, chapter 5, method of data acquisition, will outline patient selection parameters and the process of the utilisation of these modalities in providing quantitative and qualitative data.

Chapter 5

Method of data acquisition

5.1 Methodology

In 2008 Tallaght hospital introduced a new multidisciplinary diabetic foot protection clinic (DFPC). This clinic focused on treating and managing diabetic patients with existing ulceration. Every patient attending the clinic had access to Endocrinology, Orthopaedic Surgery, Podiatry, Orthotics, Tissue Viability and Vascular Surgery in a “one stop shop” environment. Results from between 2006 and 2010 showed a total of 221 lower limb procedures were performed. The number of amputations decreased from 12 during the control period (2006 – 2008) to 7 in the study period (2008 – 2010). On costing the clinic activity there was an overall saving of €114,063 per years associated with the introduction of the DFPC (Nason G.J. et al. 2012).

In 2012 the vascular laboratory sought to further enhance the diagnostic services it offers, in a bid to improve the support it provides to this clinic and indeed ulcer patients. The complexity of the patients presenting with ulceration was noted to include toe amputations and/or ulcers often preventing the standard TBI test from being performed. This led to an alternative test being sought to help with this patient cohort. There are several factors that can influence the wound healing process and one such factor is tissue oxygenation surrounding the wound, thus an adequate oxygen supply is essential.

This study was undertaken to audit results from a test introduced into the vascular service in December 2012 called transcutaneous oximetry ($tcpO_2$). $tcpO_2$ is a measurement of tissue oxygenation at a particular site. It has been growing in recognition as a test to help aid a doctor’s decision in predicting healing or whether an amputation will be the end result. In practice, patients often require an admission to hospital to observe wound healing and investigate the initial cause of the wound. Those failing to progress during admission, or those who fail to heal post intervention and/or discharge, often require readmission for further procedures. Given the introduction of this test did not cost the hospital with regards additional staffing or space, and only required minimal training, the question is, has the introduction of this test provided any clinical diagnostic value?

5.1.1 Patient selection

For the purposes of this study, patients were selected from a population which presented to both the vascular surgical outpatients (OPD) and the diabetic foot protection clinic (DFPC) with ulceration to a lower limb. Inpatients were also included who were admitted under the care of the vascular team for treatment of an active ulceration. Patients were only included in the audit if they had both tests performed ie. a set of TBI's and a tcpO₂ exam. Both diabetic and non-diabetic patients were included and in some cases both the limb with ulceration and the contra-lateral limb had tcpO₂ performed.

The medical history of all patients was reviewed and noted to include the following details

- i) Smoker / ex-smoker / non-smoker
- ii) Medicating to treat hypertension
- iii) On statin therapy
- iv) Diabetic and if so whether Type 1 or Type 2

It is widely accepted that these characteristics are known to be commonly associated with vascular disease and as previously outlined in chapter 2 section 2.1 vascular disease can be prevalent in the diabetic ulcer patient.

All results have been collated for the three year period and analysed.

Of note it is important to recognise that there may have been limitations within the study with regard to patient compliance with medications. Patients may have been hypertensive or hypercholesteraemic despite attempts at best medical management. It was not possible to quantify patient compliance with medical advice and medication requirements. It also cannot be ruled out if there were undiagnosed diabetics within the study. As discussed in section 2.0.3 there are significant numbers of undiagnosed diabetics in both Ireland and worldwide. There may also be limitations with regard to smoking status within the study. It is difficult to qualify the smoking status of patients and indeed this is a major challenge across many areas of healthcare.

5.2 Demographics

Demographics are divided into two groups

- 1) 5.2.1 analyses participant demographics
- 2) 5.2.2 analyses test variables.

5.2.1 Participant demographics

In the audited time frame, December 2012 – December 2015, there were a total of 247 patients with ulceration which attended the vascular laboratory who had a *tcpO₂* exam performed. This number of patients represented 48% of all ulcer patients that attended the laboratory in this time period. The other 52% of patients had a TBI exam only. There was no formal criteria or protocol established for ordering *tcpO₂* as this was a trial period to investigate the usefulness of the test itself. The placement of requests for *tcpO₂* exams were consultant led and determined by a clinical decision made by the vascular consultant bearing in mind the limited resources, primarily time, available. These patients represented approx. 14% of all patients going through the laboratory for the investigation of peripheral vascular disease. The inclusion criteria for this study was any person with an ulceration presenting to the vascular laboratory between December 2012 – December 2015 who had both a *tcpO₂* test performed and a corresponding TBI test. The age range was 32 – 94 years old with a mean age of 67.5years and a median age of 69 years. Of these patients 163 (66%) were male and 84 were female (34%),

5.2.2 Test variables

Of the 247 patients, 105 of them had tests performed bilaterally accounting for 210 tests. There were 142 single leg tests which resulted in an overall total of 352 tests performed. Of these, 42 tests were excluded from the initial analysis – 30 tests had no corresponding TBI's or absolute toe pressure (ATP) as a result of a toe or transmetatarsal amputation (TMA), incompressible vessels, or due to excessive patient movement. A further 12 tests were excluded as these patients went directly to theatre and were only seen post intervention. This resulted in a total number of 310 *tcpO₂* tests in the three

year period which had a corresponding set of TBI's performed. These were retrospectively analysed.

All statistical analysis was carried out on the total numbers of tests. See table figure 5.2.

	n
Tests for analysis	310
Male	204
Female	106
Current Smoker	77
Current Non Smoker	233
Hypertension	238
No hypertension	72
Statin Therapy	215
No Statin Therapy	95
Ulceration	228
No Ulceration	82
Diabetic	204
Type 1	36
Type 2	168
Non Diabetic	106

Table 5.1 Test variables

Seventy seven (25%) tests were carried out on current smokers and two hundred and thirty three (75%) were current non-smokers with one hundred and twenty five of these being ex-smokers. There were 238 (77%) tests carried out on patients who were medicating for the treatment of hypertension and 215 (69%) on statin therapy. A total of 228 tests (74%) were performed on ulcerated limbs. Two hundred and four (66%) tests were carried out on patients who were diagnosed as diabetic with 36 (18%) who were classed as Type 1 and 168 (82%) as Type 2. There were 106 (34%) tests carried out on non-diabetics.

5.3 Assessment of Lower limb arterial disease

All patients had 2 test performed, $tcpO_2$ and a set of toe Brachial indices (TBI's).

5.3.1 Transcutaneous Oxygen Pressure ($tcpO_2$)

$tcpO_2$ is a well-established non-invasive method which quantifies the amount of oxygen that diffuses from the capillaries and through the skin and only reflects the status of the capillaries i.e. nutritive flow.

Patient Preparation

No specific preparation was required on behalf of the patient for this test. Shoes, socks and any bulky clothing on their upper body were removed. The test was explained in full to the patient and any questions were answered. Patients lay supine on an examination couch.

Equipment

All $tcpO_2$ tests were carried out on a Radiometer TCM400 machine.



Figure 5.1 $tcpO_2$ machine

Electrode prepared / calibrated

All electrodes being used were placed in the channel on the machine and calibrated.

Method for performing tcpO₂

1. Patients were examined while lying supine.
2. The sensor site was located. A single standardised location for positioning of the sensor was chosen on all patients (where possible). This was on the dorsum of the foot. It was important that this site did not directly overlie a bony prominence or any superficial vessels. Flat or convex areas were most reliable. If it was not possible to use this site due to an area of ulceration the site nearest it was used.

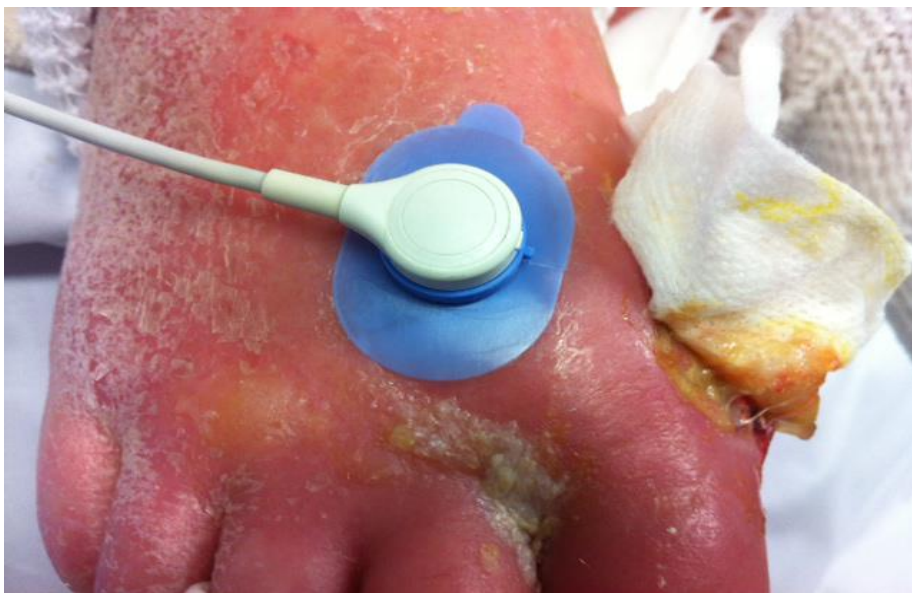

Figure 5.2 Picture of tcpO₂ probe in situ

3. The site was then prepared as follows. The chosen area was stripped with adhesive tape to remove any loose skin cells. Any hair was removed if deemed necessary. The area was cleaned with an alcohol wipe. Any open skin areas were avoided.
4. The fixation ring was then attached using its adhesive backing.
5. The centre of the fixation ring was pressed onto the measuring site with a finger and a finger was ran around the rim circumference.
6. It was important that the placement was completely airtight.
7. Approx. 4 - 5 drops of contact liquid was then placed in the fixation ring and the electrode was then attached by aligning the arrow on the sensor with the mark on the fixation ring.

8. The sensor was turned 90° clockwise to fasten it in place securely. It was important that this connection was also airtight. To increase the permeability of the skin to oxygen molecules at the measuring site, the sensor maintained a pre-set temperature of 43 – 45°C.

9. The test was performed for 20 minutes. As per supplier protocol 20 minutes was adequate physiological stabilisation time for an accurate reading. This time allowed the sensor to heat the skin and encourage the arteries dilate. Results were recorded at the end of this period.

10. In the case where the reading at the end of the 20 minutes period was less than 40mmHg the patient was given 5L of 100% oxygen per minute through a rebreather mask and the test continued for a further 10 minutes.

Results were also recorded at the end of this period.

Interpretation of $tcpO_2$ measurements

A baseline measurement of < 40mmHg was selected as the cut-off below which the test was considered as abnormal and indicative that a wound could be unlikely to heal.

A baseline measurement of > 40mmHg was selected as the cut-off above which there should be spontaneous wound healing.

It has been previously determined that values near the wound that are below 40mmHg are considered to have moderate – severe hypoxia and are potential candidates for aggressive wound healing and / or revascularisation (Sheffield P.J. 2004).

5.3.2 Toe Brachial Indices (TBI's)

Patient Preparation

No specific preparation was required on behalf of the patient for this test. Shoes, socks and any bulky clothing on their upper body were removed. The test was explained in full to the patient and any questions were answered.

Equipment

All TBI's were carried out on an Elcat Vasolab 320 machine.

Two standard blood pressure arm cuffs were used as were two 2.5cm toe pressure cuffs. An 8MHz continuous wave Doppler probe was used to insonate the Doppler waveform in the Brachial artery (BA) in each arm.

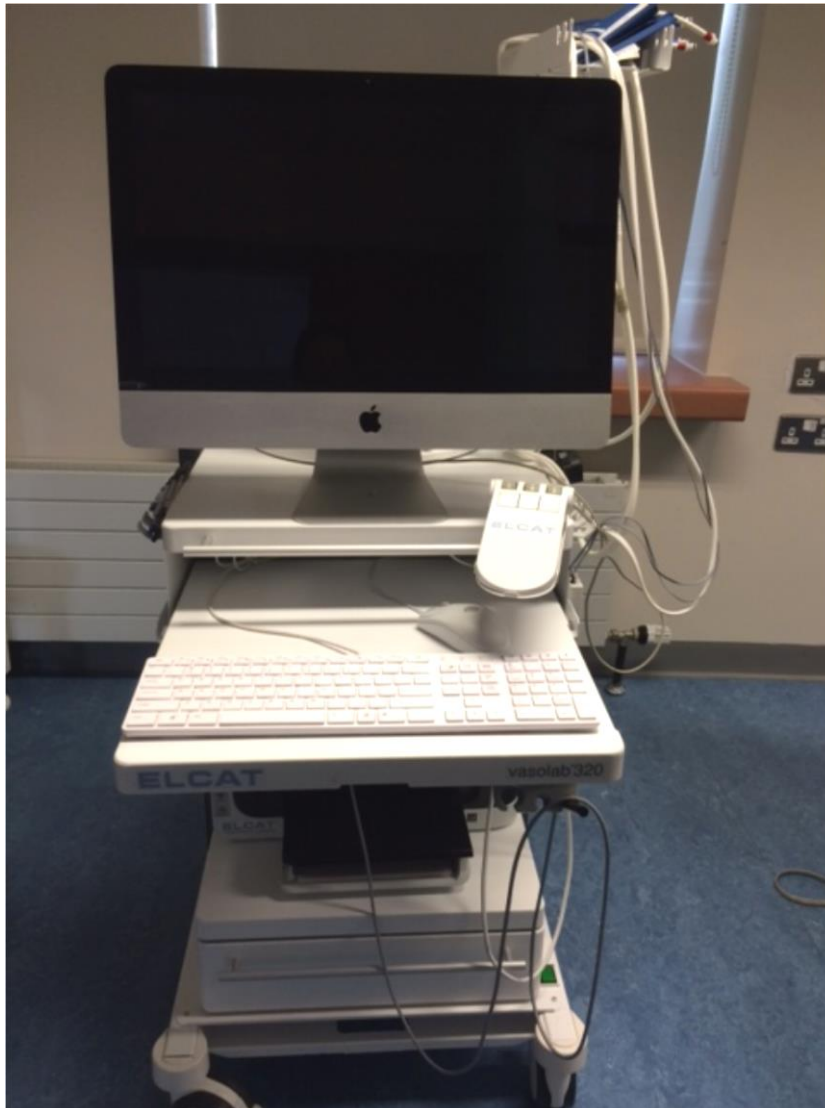

Figure 5.3 Picture of TBI and PPG machine

Method for performing a TBI

1. Patients were examined while lying supine.
2. A pneumatic cuff was carefully placed around each of the patient's arms.



Figure 5.4 Picture of arm cuff in situ

The end of an 8MHz continuous wave Doppler probe was covered in ultrasound gel and the BA in each arm was insonated.

3. While the probe was held static and the physiologist listened to the BA Doppler signal, the pneumatic cuff was inflated until the signal was inaudible. This indicated the occlusion of the artery.
4. The cuff was then slowly deflated until the BA Doppler signal returned sharply. The systolic pressure reading at this point was recorded and the remainder of the air in the cuff was rapidly deflated.
5. Steps 2 to 4 were repeated for the left arm.
6. A toe cuff was attached to each of the patient's hallux and the photoplethysmogram (PPG) sensor was also attached. The pressure in both hallux was recorded simultaneously.



Figure 5.5 Picture of toe cuff and PPG in situ

7. When a steady arterial waveform was displayed on the screen, the cuff was inflated until the waveform was obliterated indicating occlusion of the digital artery
8. The cuff was then slowly deflated until the waveform reappeared. The systolic pressure reading at this point of return was recorded.

Interpretation of Toe Brachial Measurements

In the normal limb the baseline digital index should be greater than or equal to 0.6 (Cole, Norris and Walker. 2000). TBI's are calculated as described in equation 5.1 below. If PAD is present this value will drop accordingly to its severity.

Equation 5.1 **TBI = $\frac{\text{Toe systolic pressure}}{\text{Highest Brachial systolic pressure}}$**

A systolic toe pressure measurement of < 30mmHg indicates the presence of critical ischemia (Society for Vascular Technology of Great Britain and Ireland 2001).

The digital arteries in the great toe are less affected by arterial calcification. However, this test is limited if the great toe has a wound/ulcer or there has been a previous amputation. Interpretation of toe pressure and TBI vary in the literature. In general, an absolute toe pressure (ATP) > 70 mmHg or a TBI > 0.6 is normal, with anything below these are diagnostic of PAD (Society for Vascular Technology of Great Britain and Ireland 2001).

In the diabetic group, the microcirculation often also needs to be assessed and may provide alternative diagnostic information not possible to obtain due to amputation or ulceration from the usual tests such as TBI's. Increasingly the laboratory has more patients attending who have had previous amputations and so this alternative test is required.

Chapter 6

Comparison of risk factors between $tcpO_2$ versus the absolute toe pressure results.

Comparison of risk factors between $tcpO_2$ versus absolute toe pressure (ATP) results

6.1 Aim

The aim of this chapter is to statistically analyse the results from the two tests performed, TBI's and $tcpO_2$, and to assess the various risk factors of smoking, hypertension, statin therapy and diabetes i.e. does a relationship exist between these factors relative to the results?

6.2 Method

Statistical analysis of initial test results looked at all tests in the 3 year period. The objective of this statistical analysis was to determine if the average outcomes of the two sets of data are significantly different from each other.

Initially, the distribution of results was visually assessed for each group being tested. This visual assessment was conducted to understand how best to statistically assess for differences. The distributions of test groups were seen to converge to a normal distribution though slightly skewed in some cases.

It is also important to state that results are applicable to ulcer patients and not to the wider population in general.

Given that the objective remains to compare an outcome and that the assumption of normality is less important as sample size increases (Lumley T. 2002), it was decided to use student's t tests in all cases to test for differences in the means. The tests were evaluated at a 99% significance level (p -value < 0.01) to provide a stronger degree of certainty in the results compared to a more widely used 95% significance level.

All analysis was performed using Microsoft excel 2013.

6.3 Results

All risk factors were assessed and compared with regards to both tests.

Smoking

Test	tcpO ₂ (mmHg)	ATP (mmHg)
Smoker	34	56
Non Smoker	41	72
P-Value	p = 0.006	p = 0.01
Outcome	Indicated difference	Indicated difference

Table 6.1 Analysis of smokers V's non-smokers.

Mean (\pm SD) tcpO₂ between the smokers and the non-smokers were as follows:

Smokers 34 ± 20 mmHg and the non-smokers 41 ± 19 mmHg.

There was an indicated difference (p = 0.006) between the mean tcpO₂ in smokers and the mean tcpO₂ in the non-smokers.

Mean (\pm SD) absolute toe pressures between the smokers and the non-smokers were as follows:

Smokers 56 ± 55 mmHg and the non-smokers 72 ± 46 mmHg.

There was an indicated difference (p = 0.01) between the mean absolute toe pressures in smokers and the mean absolute toe pressures in the non-smokers.

Hypertension

Test	tcpO ₂ (mmHg)	ATP (mmHg)
Hypertension	38	64
Non Hypertension	43	83
P-Value	p = 0.08	p = 0.003
Outcome	No indicated difference	Indicated difference

Table 6.2 Analysis of those medicating for hypertension V's those not medicating for hypertension

Mean (\pm SD) tcpO₂ between patients medicating for hypertension and those not medicating for hypertension were as follows:

Those on anti-hypertensive medications 38 ± 20 mmHg and those not on anti-hypertensive medications 43 ± 18 mmHg.

There was no indicated difference ($p = 0.08$) between the mean tcpO₂ in those on anti-hypertensive medications and those who were not.

Mean (\pm SD) absolute toe pressures between patients medicating for hypertension and those not medicating for hypertension were as follows:

Those on anti-hypertensive medications 64 ± 48 mmHg and those not on anti-hypertensive medications 83 ± 50 mmHg.

There was an indicated difference ($p = 0.003$) between the mean absolute toe pressures in those on anti-hypertensive medications and those who were not.

Statin therapy

Test	tcpO ₂ (mmHg)	ATP (mmHg)
Statin therapy	39	64
Not on statin therapy	40	77
P-Value	p = 0.56	p = 0.03
Outcome	No indicated difference	No indicated difference

Table 6.3 Analysis of those on statin therapy V's those not on statin therapy

Mean (\pm SD) tcpO₂ between patients on statin therapy and those not on statin therapy were as follows:

Those on statin therapy 39 ± 20 mmHg and those not on statin therapy 40 ± 20 mmHg. There was no indicated difference (p = 0.56) between the mean tcpO₂ in those on statin therapy and those not.

Mean (\pm SD) absolute toe pressures between patients on statin therapy and those not on statin therapy were as follows:

Those on statin therapy 64 ± 47 mmHg and those not on statin therapy 77 ± 53 mmHg. There was no indicated difference (p = 0.03) between the mean absolute toe pressures in those on statin therapy and those not. Of note, if the standard p value of <0.05 was used, this may of suggested a difference between the groups

Diabetes

Test	tcpO ₂ (mmHg)	ATP (mmHg)
Diabetic	39	68
Non Diabetic	40	68
P-Value	p = 0.73	p = 0.96
Outcome	No indicated difference	No indicated difference

Table 6.4 Analysis of diabetics V's non-diabetics

Mean (\pm SD) tcpO₂ between patients who are diabetic and those who are not were as follows:

Patients who are diabetic 39 ± 20 mmHg and those who are not 40 ± 19 mmHg.

There was no indicated difference (p = 0.73) between the mean tcpO₂ in the diabetic and the non-diabetic patients.

Mean (\pm SD) absolute toe pressures between patients who are diabetic and those who are not were as follows:

Patients who are diabetic 68 ± 49 mmHg and those who are not 68 ± 50 mmHg.

There was no indicated difference (p = 0.96) between the mean ATP's in the diabetic and the non-diabetic patients.

6.4 Discussion

This diagram, table 6.5, is a summary of the statistical analysis outcomes detailed in the previous section.

Tests	tcpO ₂		ATP	
	Indicated difference	No indicated difference	Indicated difference	No indicated difference
Smokers V non-smokers	√		√	
HTN V's no HTN		√	√	
Statins V's no Statins		√		√
Diabetes V's no diabetes		√		√

Table 6.5 Summary of statistical analysis per risk factor

The analysis in section 6.3, has shown that there is an indicated difference in the mean ATP's and tcpO₂ results between the smoking and the non-smoking groups. When comparing the smokers against the non-smokers with regards outcomes of these two tests, the results in the smokers in both tests are significantly lower than in the non-smokers. This outcome supports evidence that smoking impairs the body's ability to deliver oxygen effectively (Lee C.L. Chang W.D 2013, Nadel J.A. Comroe J.H. 1961) and is a significant factor in PAD due to atherosclerosis of the lower limb arteries. This ultimately can lead to ulceration.

The smoking prevalence in Ireland in 2015 was 19.2%, with the levels of smoking highest in younger adults aged between 18 – 24 years at 27.2% and in the 25 – 34 year olds at 28.5%. The lowest prevalence was in the over 65 year olds at 8.6% (Health Service Executive 2015). There are estimated to be 5500 smokers dying each year from tobacco related diseases (Health Service Executive 2016). This represents approximately 19% of all deaths. Of these deaths, 30% are attributed to circulatory diseases (U.S. Department of Health Human Services 2014).

Cigarettes are known to contain over 4000 toxic chemicals (Ginzel K.H. 2016). Nicotine is one of the main ingredients in a cigarette and this is a highly addictive substance. It is also a vasoconstrictor which is known to increase the adhesiveness of platelets in the blood, hence raising the risk of a microvascular occlusion. This in turn can lead to a reduction in nutritional blood flow to the skin. Another substance in

cigarettes is carbon monoxide. This poisonous gas binds itself to the haemoglobin in the bloodstream and prevents it from carrying enough oxygen around the body.

The association between cigarette smoking and delayed wound healing is well recognised (Silverstein P. 1992) and frequently leads to impaired perfusion. Smoking is also known to raise blood pressure which is a risk factor for other diseases such as stroke and heart attack.

Statistical analysis in Section 6.3 shows that there was an indicated difference noted between the ATP's in those on antihypertensive medications and those not. The ATP's were lower in those tests taking hypertensives. There was no difference noted in the $tcpO_2$ tests in either those medicating or those not, suggesting, that in this study hypertensive medications did not appear to affect oxygenation of the tissue.

Antihypertensives are a drug used to treat hypertension – high blood pressure. There are many classes of this drug type, which are used to lower the blood pressure by different means. The most commonly used drugs are calcium channel blockers, angiotensin-converting-enzyme (ACE) inhibitors, diuretics and beta blockers. The type of medication initially chosen to treat hypertension has been the subject of several large studies and resulting national guidelines such as the AASK trial (African American study of kidney disease and hypertension), ALLHAT trail (antihypertensive and lipid lowering treatment to prevent heart attack trial), NICE (National institute for healthcare and care excellence), and JNC8 (Eight joint national committee on the prevention, detection, evaluation and treatment of high blood pressure) to name a few (Dewland T.A. et al. 2016, James P. A. et al. 2014, National Clinical Guideline Centre 2011, Norris et al. 2006). These trials looked at the various methods used to treat hypertension. They also assessed mono therapy versus dual therapy with regard to the various combinations of treatment in the various patient groups depending on risk factors. Treatment of hypertension needs to be individualised. Antihypertensives reduce cardiac output and/or peripheral resistance. Hypertension is associated with all forms of cardiovascular disease and peripheral arterial disease (PAD). The relative risk for developing PAD is noted to be less for hypertension than other risk factors such as diabetes or smoking (Norgren L. et al. 2007). The interaction between tissue oxygenation and antihypertensives is poorly studied.

The statistical analysis in Section 6.3 shows that there was no indicated difference noted between either the $tcpO_2$ or ATP's in those that were on statin therapy versus those not.

This suggests, that in this study statins did not appear to affect oxygenation of the tissue or blood perfusion. Of note, if the standard p value of <0.05 was used, this may of suggested a difference between the groups.

Statins are described as a lipid lowering drug and can be grouped into either low intensity, medium intensity or high intensity categories (NICE guidelines).

The type of medication initially chosen to treat patients has also been the subject of many studies, with the NICE guidelines advocating all diabetics should be placed on statin therapy (National Institute for Health Care Excellence 2016a). There appears to be no one direct cause for hyperlipidaemia, so the treatment also must be multifaceted.

There is evidence that treatment of hyperlipidaemia reduces both the progression of PAD and the incidence of claudication (Norgren L. et al. 2007). This directly impacts on disease progression which can lead to ulceration. Statins not only lower the risk of vascular events but they also improve the symptoms of PAD. (Coppola G. Novo S. 2007). The Heart Protection Study (HPS) has published evidence that supports the routine use of statins in patients with PAD regardless of their cholesterol levels (Al Mahameed A. 2009, Heart Protection Study Collaborative Group 2002). It has also been suggested that cigarette smoking may enhance the effect of hypercholesterolemia. As is the case with antihypertensives the interaction between tissue oxygenation and statins is poorly studied.

The statistical analysis in Section 6.3 shows that there was no indicted difference noted between either the $tcpO_2$ or ATP's in those that were diagnosed diabetic versus those not.

In general all diabetic patients tend to be medicated tightly in a bid to reduce their long term complications, including arterial disease, renal failure, ocular complications and peripheral neuropathy. Many studies have shown an association between diabetes mellitus and the development of PAD. Claudication is approximately two times more

common in diabetic patients than in non-diabetic patients. In patients with diabetes, for every 1% increase in haemoglobin A1c there is a corresponding 26% increased risk of PAD (Norgren L. et al. 2007). PAD in patients with diabetes is more aggressive compared to the non-diabetics, and coupled with neuropathy this can lead to significant problems as mentioned earlier in chapter 2, section 2.1.

Sixty six percent of tests in the study were diabetic with 74% of tests having an ulcer. The sample patients in this study is based primarily on those with ulcers and/or those referred to a vascular or a foot protection clinic.

Can the majority of ulcers in these patients be considered neuropathic in origin (rather than vascular) and can this account for the absence of a difference between diabetics and non-diabetics in this study population? Is neuropathy the more dominant cause of ulceration in these diabetic patients rather than arterial disease? In addition to this, while the proportion of those with PAD is higher among diabetics than in the normal population, the non-diabetic group in this study presented due to the fact that there was a concern about their peripheral arterial supply (they presented with an ulcer). This will be further discussed in chapter 8.

The outcome of this chapter would confirm smoking as the one single risk factor that has had a negative impact on both tests and hence effects both the macro and micro circulation. In patients who are smokers, the body's ability to heal ulceration is diminished with regards to both blood perfusion and tissue oxygenation. Hypertension and hypercholesterolemia are closely linked to the severity of arterial disease and often medications used to treat them are commonly prescribed with a dual function eg: antihypertensives can also be used as a vasodilator to improve flow to extremities and not just or only for hypertension. The outcomes in this work are suggestive, that these medications have an effect on the macro circulation only, and seem to have spared the micro circulation.

The tests in this audit have a large number of diabetics (66%) and a large cohort of ulcerations (74%), which have a burden of disease that we know will result in the prescribing of the aforementioned medications. International research has shown that these risk factors have a proven negative impact on ATP's and TBI's and the

prescribing of these drugs is performed in a bid to reduce this and its severity. This study has determined that diabetes or the use of antihypertensives and/or on statin therapy does not have a clearly defined impact on $tcpO_2$ results, whereas they do have an impact on ATP's. In a certain patient cohort both tests should be considered. $tcpO_2$ is a non invasive and cheap test, which can provide additional diagnostic information, that can perhaps be equally as valuable as a set of TBI's in assessing perfusion and healing potential. It is also seen in this study that they are not affected by certain risk factors to the same extent as ATP's and TBIs are.

In the following chapter, further analysis was performed by directly comparing the results from the two tests against each other. This will aid in better determining the role of $tcpO_2$.

Chapter 7

Comparison of results between $tcpO_2$ and the TBI tests

Comparison of results between $tcpO_2$ and the TBI tests

7.1 Aim

The aim of this chapter is to analyse initial results of TBI's and $tcpO_2$ examinations in all patients, and the relationship that exists directly between the two tests, if any.

7.2 Method

This study has looked at two different tests performed on a set of patients which have all presented to the vascular laboratory with foot ulceration. TBI's looked at pressure as an indicator of arterial perfusion of a limb/toe and $tcpO_2$ looked at tissue oxygenation at a particular site on the foot. In some cases, the non-ulcerated contralateral limb had both tests also recorded. Firstly a correlation coefficient was performed on the results from both tests in Microsoft excel 2013. Subsequently, the results from all the tests were plotted against each other using an X,Y scatter graph. This was also performed in Microsoft excel 2013.

7.3 Results:

Correlation coefficient: When the TBI's and $tcpO_2$ results were compared, the correlation coefficient was 0.49. When absolute toe pressures and $tcpO_2$ results were compared the correlation coefficient was also 0.49.

Scatter Graph:

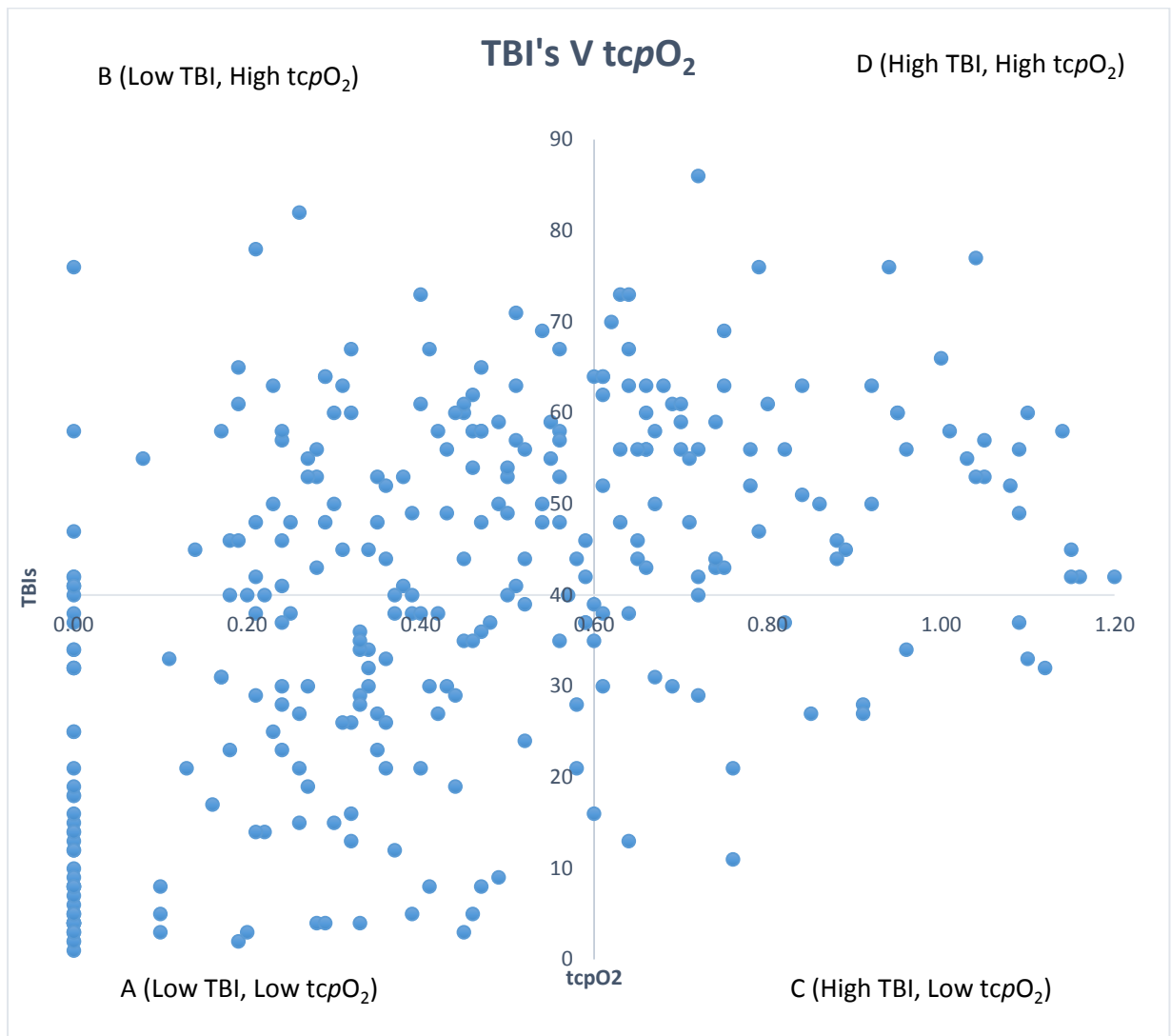

Figure 7.1 TBI & tcpO₂ scatter graph

Graph details:

The two axes were marked as follows;

Centre horizontal axis: TBI's, with the axis intersecting at 0.60 which is the value classed as a normal outcome for a TBI result (Cole, Norris and Walker. 2000).

Centre vertical axis: tcpO₂, with the axis intersecting at 40mmHg which is the marker above which spontaneous wound healing is likely in normal patients (Sheffield P.J. 2004).

Plot area or quadrant A (Low TBI and Low $tcpO_2$ group) are the results from both tests that were below the normal threshold i.e. the TBI was < 0.6 and $tcpO_2$ was $< 40\text{mmHg}$. Results from the tests that fell into this quadrant were both below the normal values and classed as abnormal. 39% of all tests fall into this quadrant.

Plot area or quadrant D (High TBI and High $tcpO_2$ group) are the results from both tests that were above the normal threshold i.e. the TBI was > 0.6 and $tcpO_2$ was $> 40\text{mmHg}$. Results from the tests that fell into this quadrant were both above the normal values and classed as normal. 24% of all tests fall into this quadrant.

Plot area or quadrant B (Low TBI and High $tcpO_2$ group) are the results from both tests were the TBI result is low (<0.6) but the $tcpO_2$ result is above the normal threshold ($> 40\text{mmHg}$). Results from the tests that fell into this quadrant have one test with normal values and the other with abnormal values. 31% of all tests fall into this quadrant.

Plot area or quadrant C (High TBI and Low $tcpO_2$ group) are the results from both tests were the TBI result is high (>0.6) but the $tcpO_2$ result is below the normal threshold ($< 40\text{mmHg}$). Results from the tests that fell into this quadrant have one test with normal values and the other with abnormal values. 6% of all tests fall into this quadrant.

All four quadrants have been statistically compared to the overall population of results using a One Sample Proportion T-Test. A P-value less than 0.05 was considered significant. These tests were performed using Microsoft excel 2013.

The results from these were as follows:

A or Low TBI and Low tcpO₂ group

- There are significantly more tests with ulcers in the low TBI and low tcpO₂ group compared to overall tests (P-value 0.00073). A total of 87.5% of tests in this group have an ulcer compared to overall tests of 73.5% with ulcers.
- There are significantly more tests with hypertension in the low TBI and low tcpO₂ group compared to overall tests (P-value 0.0069). A total of 85.8% of tests in this group have hypertension compared to overall tests of 76.7% with hypertension.
- Of note there was no statistically significant difference in the proportion of non-smoker tests present in the low TBI and low tcpO₂ group compared to the overall tests (P-value 0.078) but it was noted to be borderline. There were only 27.5% non-smokers in this group compared to the overall total of 34.8%.

B or Low TBI and High tcpO₂ group

- There are significantly more tests on statin therapy in the low TBI and high tcpO₂ group compared to overall tests (P-value 0.0452). A total of 77.3% of patients are taking statin therapy in this group compared with the overall total of 69.3%.
- Of note there was no statistically significant difference in the proportion of ex-smokers (P-value 0.0531) or non-smokers (P-value 0.0921) present in the low TBI and high tcpO₂ group compared to the overall tests, but it was noted to be borderline. There were 49.5% ex-smokers in the group with overall total at 40.3% and 27.8% of non-smokers in the group with the overall total at 34.8%. There were slightly less smokers in this group – actual 22.7% versus overall total of 24.8%.

C or High TBI and Low tcpO₂ group

- There were no statistically noted differences in any areas in this group.
- Of note there was no statistically significant difference in the proportion of ulcer tests present in the high TBI and low tcpO₂ group compared to the overall tests (P-value 0.083) but it was noted to be borderline. There were 80% ulcer tests in this group compared to the overall total of 73.5%.

Overall it is important to note that the numbers in this groups are very small.

D or High TBI and High tcpO₂ group

- There are significantly more tests who are non-smokers in the high TBI and high tcpO₂ group compared to overall tests (P-value 0.0000006). A total of 56.2% of tests in this group are non-smokers compared to overall tests of 34.8%.
- There are significantly less tests who are ex-smokers in the high TBI and high tcpO₂ group compared to overall tests (P-value 0.000014). A total of 24.7% of tests in this group are ex-smokers compared to overall tests of 40.3%.
- There are significantly less tests who have ulcers in the high TBI and high tcpO₂ group compared to overall tests (P-value 0.00000022). A total of 53.4% of tests in this group have ulcers when compared to overall tests of 73.5%.
- There are significantly less tests who have hypertension in the high TBI and high tcpO₂ group compared to overall tests (P-value 0.00000044). A total of 57.5% of tests in this group are medicating for hypertension compared to overall tests of 76.73%.
- There are significantly less tests who are on statin therapy in the high TBI and high tcpO₂ group compared to overall tests (P-value 0.012). A total of 57.5% of tests in this group are medicating with statins compared to overall tests of 69.3%.
- There are significantly more tests who are female in the high TBI and high tcpO₂ group compared to overall tests (P-value 0.0413). A total of 43.8% of tests in this group are female compared to overall tests of 34.2%.

7.4 Discussion

Correlation Coefficient

A positive correlation is when the correlation coefficient is greater than 0 with a +1 signifying a perfect positive relationship. This simply means that both variables move in the same direction. It indicates a direct relationship, which means, that as one variable increases the other variable also increases.

Likewise, a 0 indicates no correlation, with a -1 indicating a perfect negative correlation.

The correlation coefficient between the $tcpO_2$ and TBI tests was 0.49. While this is not a perfect correlation it is indeed a positive one. When using either the TBI index or the ATP, both correlation coefficients equated to 0.49. This suggested there was no difference in diagnosis related to the type of perfusion measurement used, TBI or ATP.

Of interest and as stated earlier these tests measure two different functions and can be concluded to perhaps offer different degrees of diagnostic information to the clinician.

Scatter graph:

This diagram, table 7.2, is a summary as per quadrant of the statistical analysis outcomes detailed in the results section of this chapter.

↑statins B (Low TBI, High tcpO ₂)	↓Ulcers ↓Hypertension & statins ↓Ex-smokers ↑Female ↑Non-smokers D (High TBI, High tcpO ₂)
↑Ulcers ↑Hypertension A (Low TBI, Low tcpO ₂)	C (High TBI, Low tcpO ₂)

Figure 7.2 Summary of statistical analysis per quadrant

Quadrant A (low TBI and low tcpO₂ group) and D (high TBI and high tcpO₂ group) account for a combined total of 63% of all test results. Both test results in each quadrant have the same outcome i.e. both with a normal result or both with an abnormal result. One test offers no different information to the other. These are classed as concordant tests.

Quadrant B (low TBI and high tcpO₂ group) and C (high TBI and low tcpO₂ group) account for a combined total of 37% of test results and have two different results i.e. opposite outcomes. One test result is normal and the other abnormal. These are classed as discordant tests and are of most interest because of their discordance. Quadrant B (low TBI and high tcpO₂ group) accounts for 31% of tests while quadrant C (high TBI and low tcpO₂ group) represents only 6% of all tests.

To assist in the discussion of graph analysis, each of the quadrants are detailed in the table below showing the actual percentage of tests in each quadrant and the breakdown of the associated risk factors. The overall percentage outcomes for the entire test group are also shown in table 7.2 for means of comparison.

	A (LL)	B (LH)	C (HL)	D (HH)
Male	71	68	60	56
Female	29	32	40	44
Smokers	30	23	25	19
Ex-Smokers	42	49	40	25
Non-Smokers	28	28	35	56
Ulcers	88	70	80	53
Non-Ulcers	12	30	20	47
HTN	86	82	70	58
No HTN	14	18	30	42
On Statin	71	77	65	58
Not on statin	29	23	35	42
DM	68	70	65	56
No DM	32	30	35	44
T1	17	22	8	15
T2	83	78	92	85
TBI	0.21	0.34	0.78	0.81
tcpO ₂	20	53	29	56

Table 7.1 Actual % outcomes per group

Male	66
Female	34
Smokers	25
Ex-Smokers	40
Non-Smokers	35
Ulcers	74
Non-Ulcers	26
HTN	77
No HTN	23
On statin	69
Not on statin	31
DM	66
No DM	34
T1	18
T2	82

Table 7.2 Overall results population % outcomes

Graph analysis will be divided into two groups, a concordant group where the tests results have the same outcome and a discordant group where the tests have opposite results.

7.4.1 Concordant tests

Low TBI & Low tcpO₂ group (A) – (120 tests or 106 patients - 14 had bilateral tests)

Statistical analysis has shown a significantly higher number of ulcerations in this group. Of all tests in the study where both outcomes are abnormal (i.e. this group), 88% of them presented with ulceration. An abnormal result was diagnosed when the TBI result was less than 0.6 and a tcpO₂ value was less than 40mmHg. Patients have a higher risk of developing ulceration with both a low TBI and low tcpO₂. This often results in the healing of an ulceration being very difficult as both the perfusion and oxygenation of the tissue are compromised. In this case spontaneous healing is difficult and intervention is often required. In this group there were a total of 66 interventions on 61 patients. When broken down there were 38 angioplasty procedures (on 33 patients - 3 patients had bilateral angioplasty's with 2 having 2 redo's), 27 bypass procedures (on 25 patients - 2 patients had bilateral grafts) and 1 common femoral endarterectomy. Amputations can often be a likely final outcome. Within this group there were 48 toe amputation procedures (on 46 patients – 2 patients had 2 toes amputated), 20 TMA's (transmetatarsal amputations - on 20 patients) with 13 of these having had a preceding toe amputation. There were 12 BKA's (below knee amputation on 12 patients) with 6 having a previous TMA and 4 a previous toe amputation. There was 5 AKA's (above knee amputation on 5 patients) with one having a previous TMA and 2 having previous toe amputations. These are a difficult cohort to manage and often have a very complex medical history.

Statistical analysis has also shown a significantly higher rate of tests medicating for hypertension in this low TBI and low tcpO₂ group which is probably likely due to individual medical history and overall risk of disease.

High TBI & High tcpO₂ group (D) (73 tests or 55 patients -18 had bilateral tests)

Conversely to group A, statistical analysis has shown a significantly lower number of ulcerations in this group. Of all tests in the study where both outcomes are normal (i.e. this group) only 53% of them had an ulceration. Both perfusion and oxygenation of tissue is above normal standards in these tests hence reducing the risk of ulceration. Even though ulceration is present despite normal test results, there are other reasons why patients develop ulcers (discussed in chapter 2) such as venous disease,

neuropathy, infection of a wound and foot deformities. With both tests having normal results these patients are more likely to heal their ulcers without interventions and less likely to require amputation. In this group there were no revascularisation interventions. There were 4 amputations, with 2 (2 patients) toe amputation procedures due to osteomyelitis and 1 TMA also due to the same reason. There was 1 BKA due to a Charcot foot with an associated non-healing ulcer in the presence of adequate perfusion. Of note osteomyelitis is an infection which is treated firstly with antibiotics and if this fails requires amputation of the infected area

Statistical analysis did show less tests who were ex-smokers in this group but it also showed significantly more tests who were non-smokers. We know smoking affects peripheral circulation and has a damaging effect on both the arteries and tissue oxygenation, so it is understandable this group has been subjected to less of the damage smoking causes. There were 56% of tests classed as non-smokers in high TBI and high $tcpO_2$ group versus 28% in the low TBI and low $tcpO_2$ group, 28% in the Low TBI and high $tcpO_2$ group and 35% in the high TBI and low $tcpO_2$ group.

Statistical analysis has also shown a significantly lower rate of tests medicating for hypertension and on statin therapy in this high TBI and high $tcpO_2$ group, which is probably likely due to medical history and their overall risk of disease as was seen in the low TBI and low $tcpO_2$ group.

Of note and which was not deemed statistically significant it can be seen that there were less diabetics in the high TBI and high $tcpO_2$ group than in the low TBI and low $tcpO_2$ group, and indeed any other group. There were 56% of test diabetics in the high TBI and high $tcpO_2$ group versus 68% in the low TBI and low $tcpO_2$ group, 70% in the low TBI and high $tcpO_2$ group and 65% in the high TBI and low $tcpO_2$ group.

In these groups both tests have similar outcomes and provide no additional information to aid in the treatment of patients. Perhaps if anything with tests that are just borderline normal or abnormal, perhaps if the other test result is not borderline it may encourage further diagnostic investigation.

7.4.2 Discordant tests

High TBI & Low tcpO₂ group (C) (20 tests or 20 patients)

In comparison to other groups, the statistical analysis of the tests in this group has shown no significant differences with regards risk factors or ulcer numbers.

Group C with a high TBI and a low tcpO₂ result accounts for just 6% of the tests in the study. When this group was further analysed the average TBI was 0.78 with an average ATP of 126mmHg. The average tcpO₂ baseline was 29 mmHg which increased to 58 post 10 minutes O₂ as per the protocol described in chapter 5.3.1. There were noted to be no interventions in this group.

There are two points to be considered here:

1) falsely elevated digital pressures due to calcification. Digital arteries can become incompressible due to medial sclerosis or calcification. Within this group there were 6 tests which had a digital x-ray and were reported as having vascular calcification, but the overall number of patients with digital x-rays is inadequate to be quantified and to draw any conclusion. Further research in this area is required.

2) falsely depressed tcpO₂ must also be considered. This can be attributed to a number of factors including soft tissue infection, oedema, venous hypertension, steroids, other immunosuppressants or inadequate nutrition (Fife et al. 2009).

Of note there were 6 patients who had osteomyelitis with 5 of these requiring a toe or toes to be amputated and one resulting in a BKA. Although the baseline is low the response to the inhaled 100% O₂ was good, which suggests that perhaps many of these patients are not as ischaemic as their baseline values might suggest. Further study in this area should be considered. Perhaps a centrally placed truncal sensor measurement would be helpful in further investigating this.

Low TBI & High tcpO₂ group (B) (97 tests or 82 patients – 15 had bilateral tests)

This discordant group with its low TBI and high tcpO₂ results account for 31% of all tests in the study.

When statistical analysis was carried out on this group, the number of tests on statin therapy (77%), was significantly statistically higher than in comparison to the other groups and also higher than the overall number of tests (69%). It was shown in chapter

3, section 6.3.3 that there is a significant difference in ATP in those on statin therapy versus those not, with there being no difference in $tcpO_2$ results between those on statins versus those not. ATP's are lower in the test group on statin therapy. Although not significantly relevant it was noted that the number of tests medicating for hypertension in this group was also 5% higher than the overall number of tests. It was also shown in chapter 3, section 6.3.2 that there is a significant difference in ATP's in those on antihypertensives versus those not. Likewise, those on antihypertensives had reduced ATP's. This finding concurs with the groups with low TBI's, which have large numbers of tests medicating for either hypertension and/or taking a statin and vice versa in the groups where the TBI's are normal, the number of tests medicating for hypertension and/or taking a statin are reduced.

The number of ulcers in this group stands at 70% giving it a lower number of actual ulcers by 4% than the overall number of ulcers. The number of diabetics in this group also stands at 70% which is 4% higher than the overall number (22% of these diagnosed as Type 1 which is 4% higher than the overall number). In general all diabetic patients tend to be medicated tightly in a bid to reduce the negative impacts it can have on the body.

The average TBI result in this group was 0.34 with 0.6 considered a normal outcome. There were 11 (97 in total in the group) tests that were borderline abnormal, with the results between 0.6 and 0.55. Fifty two tests were above the average TBI of 0.34, with 45 below the average of 0.34.

The average ATP was 55mmHg with the average $tcpO_2$ at 53mmHg.

There were 11 interventions in total which divided into 6 angioplasty's on 6 patients and 5 bypass grafts on 5 patients.

There were 21 toe amputations on 21 patients. There were 7 TMA's with one patient having bilateral TMA's. Within these 6 TMA patients, 4 had a previous toe amputation. There were 6 BKA's on 6 patients with 4 AKA's on 4 patients (one of these being a revised BKA due to infection).

Flow chart 7.1 shows the numbers of tests with a TBI < 0.6, which is divided into two groups - $tcpO_2 < 40$ and $tcpO_2 > 40$. These are subdivided into interventions and amputations.

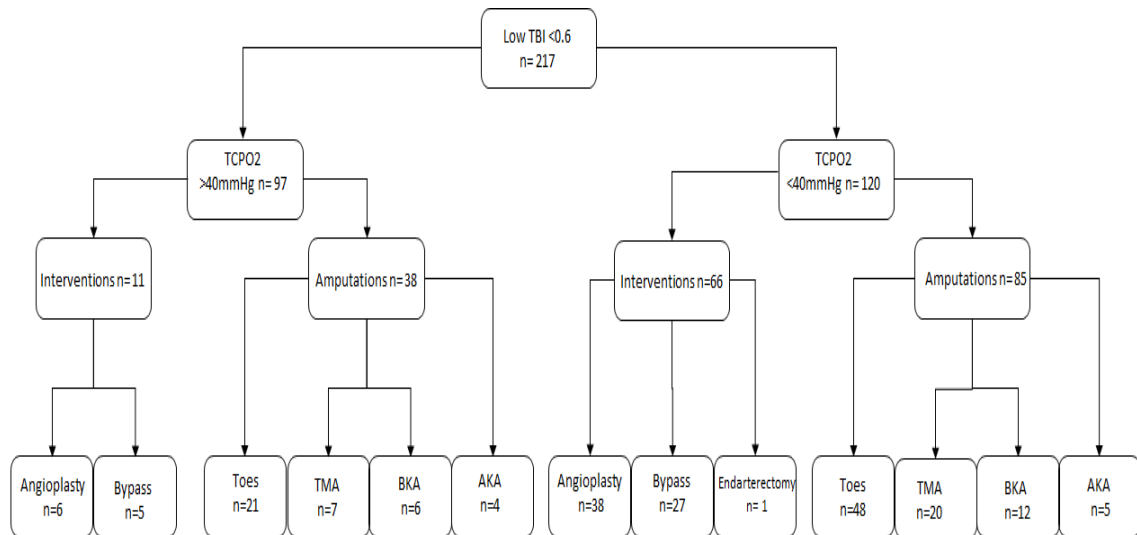

Flow chart 7: Tests with a TBI < 0.6

In summary the numbers in group B (low TBI and high $tcpO_2$) regarding interventions and amputations are relatively large in comparison with the other groups C & D. (See table 7.3 below)

Group	A (LL)	B (LH)	C (HL)	D (HH)
Overall test numbers	120	97	20	73
Interventions	66	11	0	0
Toe/s amputated	48	21	5	2
TMA's	20	7	0	1
BKA's	12	6	1	1
AKA's	5	4	0	0

Table 7.3 Intervention/amputation numbers of tests across all the groups

This table 7.3, looks at numbers of tests with regards to interventions and amputations. In some cases one or more interventions or amputations can be attributed to one patient;

for example a patient may have had an angioplasty or bypass graft and gone on to lose one toe or more which may have then ended in a TMA or BKA.

Groups C (High TBI & low $tcpO_2$) & D (High TBI & high $tcpO_2$) fair best with no interventions and small numbers of amputations, although the overall number of tests in group C are quite low.

Group A, which has low results in both tests, has the largest numbers of both interventions and amputations and also the largest number of actual tests in the study.

Group B which also has a low TBI result, but, has a high $tcpO_2$ result, is noted to be the second largest group in the study. This group has a very obvious lower number of interventions and amputations.

In conclusion the low TBI and high $tcpO_2$ or group B is of particular interest because of its discordant tests and of the numbers of tests that fall into it. It suggests that in this patient cohort both tests are important in their own right. This group although it has a significant incidence of arterial disease and has required a number of interventions, the proportions of these are significantly lower when compared to the low TBI **low** $tcpO_2$ group. This would indicate that even in the presence of proven arterial disease i.e. reduced TBI's, that if the $tcpO_2$ result is $> 40\text{mmHg}$ that intervention does not need to be the first treatment choice. Traditionally in the setting of ulceration with critical ischaemia, reconstructive surgery or even amputation has been required. Now with the emergence of $tcpO_2$ and with its evolving recognition as a valuable diagnostic tool, perhaps a "wait and see" approach can be taken. This low cost test can lead to a reduction in the need for expensive imaging tests and even some primary interventions, resulting in an overall reduction in the financial burden of this cohort on an acute primary care facility. This study has proven that $tcpO_2$ is a valuable and complimentary test to the traditional TBI's in ulcerated patients. Of note, more importantly, in a setting where TBI's can't be performed due to amputation or ulceration of the hallux, $tcpO_2$ should be considered as the alternative first choice test.

The next chapter focuses specifically on the ulcer patients and details the outcomes in relation to these test results.

Chapter 8

Examination of factors affecting ulcer outcomes

Examination of factors affecting ulcer outcomes

8.1 Aim

As this $tcpO_2$ test was introduced to explore the diagnostic options for patients attending the diabetic foot protection clinic, further analysis of data focused on all tests performed on patients who had an active foot ulceration and more specifically those who were diagnosed as diabetic.

8.2 Method

Statistical analysis of all tests in the 3 year period was undertaken and included student's t tests which was used to determine if two sets of data are significantly different from each other. The tests were evaluated at a 95% significance level (p-value < 0.05). These tests were performed using Microsoft excel 2013. Further analysis of data in the chapter used the Fishers exact test. This tests is used to examine the significance of the association (contingency) between the two kinds of classification of data and is more appropriate when sample sizes are small.

8.3 Results

There were 310 tests analysed in which 228 were performed on ulcerated limbs and 82 on limbs without ulceration. The tests labelled as non ulcerated tests were taken from patients who had an ulcer on the contralateral limb.

Figure 8.1 below, shows the breakdown of the risk factors in the ulcer versus the non-ulcer groups. There were more smokers in the ulcer group, 27% versus 19% in the non-ulcer group. There were 83% of the ulcer group medicating for hypertension versus 62% in the non-ulcer group. There were 72% of the ulcer group on statin therapy versus 64% in the non-ulcer group. Finally there were 74% of the ulcer group that were diabetic versus 42% in the non-ulcer group.

Percentage risk factors in the ulcer versus the non-ulcer test groups

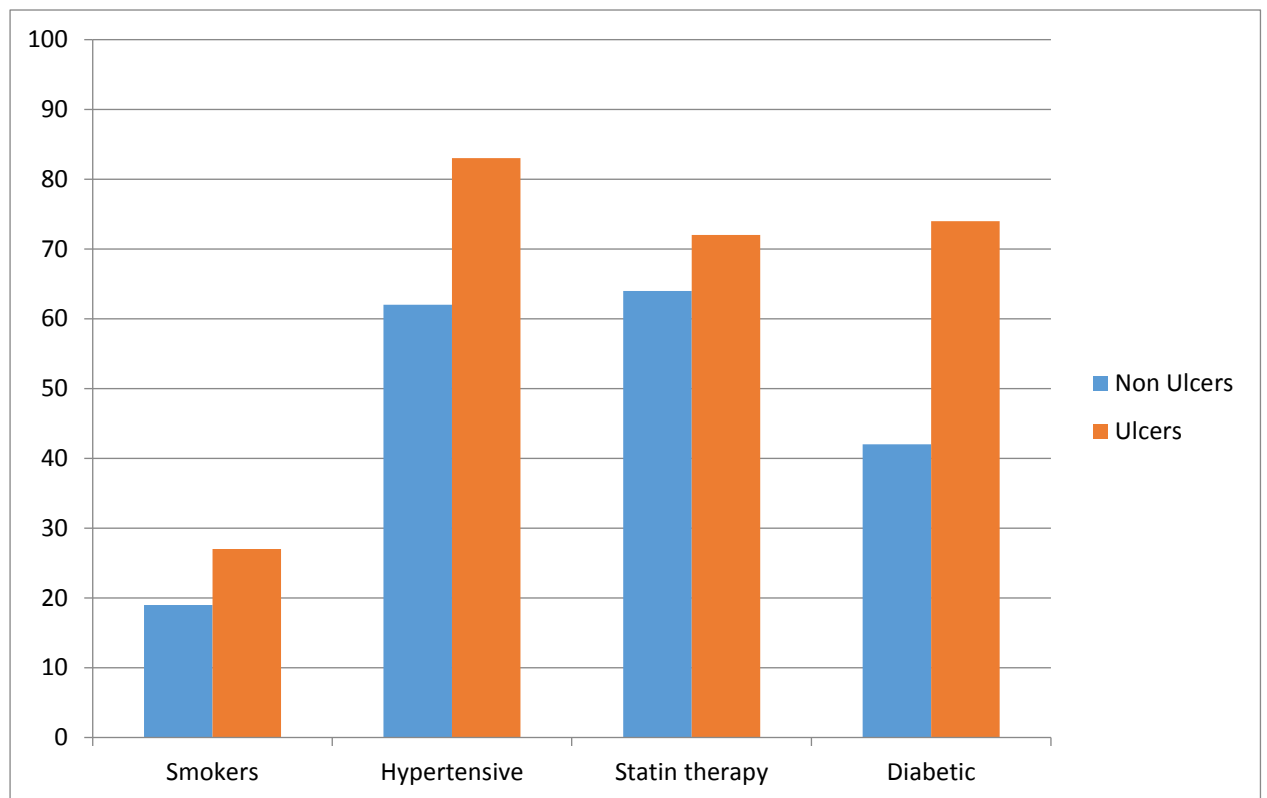

Figure 8.1 Comparisons of risk factors in the ulcer V's non-ulcer tests

8.3.1 Analysis of *tcpO₂* and ATP's in the ulcer and non-ulcer patients

The following chart shows the results when the two tests were compared in patients with an ulcer present versus those with no ulcer.

Test	<i>tcpO₂</i> (mmHg)	ATP (mmHg)
Ulcer	37	63
No ulcer	47	81
P-Value	p = 0.00014	p = 0.005
Outcome	Indicated difference	Indicated difference

Table 8.1 *tcpO₂* and ATP's in the ulcer and non-ulceration group

Mean (\pm SD) *tcpO₂* between tests with ulceration and those with no ulceration were as follows:

Those with ulceration 37 ± 20 mmHg and those with no ulceration 47 ± 17 mmHg.

There was an indicated difference ($p = 0.00014$) between the mean *tcpO₂* in the tests with ulceration and those without.

Mean (\pm SD) absolute toe pressures between tests with ulceration and those with no ulceration were as follows:

Those with ulceration 63 ± 49 mmHg and those with no ulceration 81 ± 47 mmHg.

There was an indicated difference ($p = 0.005$) between the mean absolute toe pressures in the tests with ulceration and those without.

8.3.2 Analysis of patients with ulceration – Diabetic V’s non-diabetic patients and if $tcpO_2$ is significant

Of the total 228 ulcer tests, 170 (75%) of these were diabetics. There were 82% of these diagnosed as Type 2 and 18% as Type 1. The non-diabetic group were patients who were classified as not having diabetes at the time of presentation.

Test	$tcpO_2$ (mmHg)	ATP (mmHg)
Diabetic	39	66
Non diabetic	32	55
P-Value	p = 0.04	p = 0.16
Outcome	Indicated difference	No indicated difference

Table 8.2 $tcpO_2$ and ATP’s in tests with ulceration in both the diabetic and non-diabetic group.

Mean (\pm SD) $tcpO_2$ in ulcer tests that were diabetic and those that were not were as follows:

Ulcer tests in the diabetic group 39 ± 20 mmHg and those ulcers that were not diabetic 32 ± 19 mmHg.

There was an indicated difference (p = 0.04) in the mean $tcpO_2$ between the diabetic and non-diabetic patient tests in the ulcer group.

Mean (\pm SD) absolute toe pressures in ulcer tests that were diabetic and those that were not were as follows:

Ulcer tests on those that were diabetic 66 ± 49 mmHg and those ulcers that were not diabetic 55 ± 49 mmHg.

There was no indicated difference (p = 0.16) between the mean absolute toe pressures in the ulcer group between the diabetic and non-diabetic patient.

8.3.3 Analysis of diabetic tests with ulceration – Type 1 V's Type 2 tests

Test	tcpO ₂ (mmHg)	ATP (mmHg)
Type 1	40	61
Type 2	38	67
P-Value	p = 0.84	p = 0.39
Outcome	No indicated difference	No indicated difference

Table 8.3 tcpO₂ and ATP's in the type 1 versus type 2 diabetics

Mean (\pm SD) tcpO₂ in ulcer tests who were Type 1 diabetic and those who were Type 2 diabetic were as follows:

tcpO₂ on ulcer tests with Type 1 diabetics 40 ± 19 mmHg and those ulcers who were Type 2 diabetic 38 ± 21 mmHg.

There was no indicated difference ($p = 0.84$) between the mean tcpO₂ in the ulcer Type 1 diabetic and ulcer Type 2 diabetic patient tests.

Mean (\pm SD) absolute toe pressures in ulcer tests who were Type 1 diabetic and those who were Type 2 diabetic were as follows:

Absolute toe pressures on ulcer tests with Type 1 diabetes 61 ± 48 mmHg and those ulcers who were Type 2 diabetic 67 ± 49 mmHg.

There was no indicated difference ($p = 0.39$) between the mean absolute toe pressures in the ulcer Type 1 diabetic and ulcer Type 2 diabetic patient tests.

8.4 Ulceration outcomes

The final analysis was focused on the smaller subgroup of patients with diabetes and active foot ulceration in an attempt to identify the potential utility of $tcpO_2$ in (1) determining the likelihood that an ulcer will heal without the need for revascularisation; (2) in identifying those patients who are likely to require operative revascularisation and (3) identifying the success or otherwise of a vascular intervention in altering tissue oxygenation levels. The flow chart below details the breakdown of test numbers.

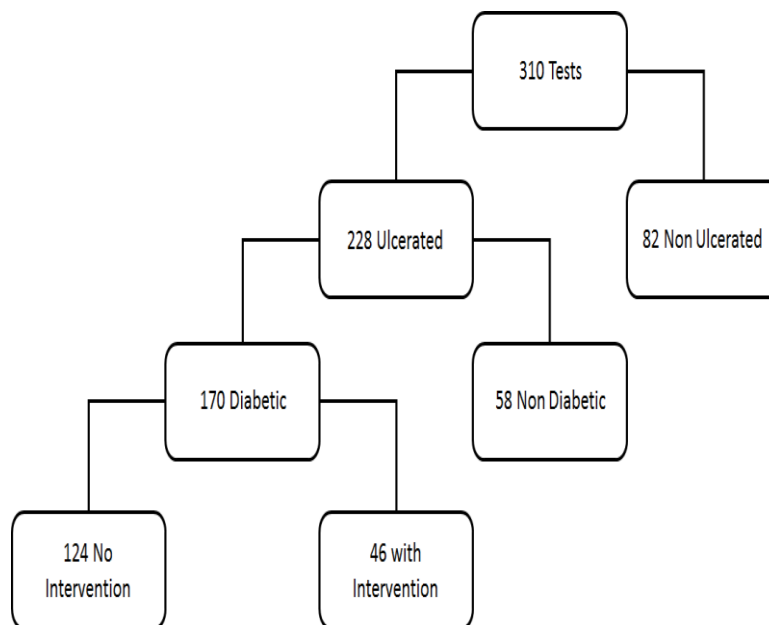

Flow Chart 8: Breakdown of tests

The total patient population of 170 with diabetes and foot ulceration were followed in the clinic during the period of the study. The outcome of each ulcer at the conclusion of the study was categorised into two groups as below:

- 1) those who had no revascularisation interventions such as an angioplasty, endarterectomy or bypass procedures
- 2) those who had some form of intervention carried out.

Each of the groups were further broken down into two distinct categories. These categories were determined as per a review of the patients chart post an outpatient appointment during treatment or follow up of their ulceration. These were as follows:

- Healed – skin closed over and ulcer completely healed
- Non – healed – no significant improvement noted in ulcer size/area and ongoing ulcer dressings required +/- a vascular intervention. For the purposes of analysis, these were treated as non-healed as the final outcome could not be determined.

The following two sub-sections will analyse the tests separately with regards those which had an intervention and those which didn't.

8.4.1 Non intervention tests

Of the 170 diabetic ulcer tests, 124 had no interventions within the time line of the study and these were evaluated and monitored until the end of the treatment period with regards to their treatment/outcome.

Two analyses were performed comparing the healing/non-healing groups using $tcpO_2$ and absolute toe pressures (ATP's). Based on the literature, a cut off of 30mmHg was used for ATP's and 40mmHg for $tcpO_2$. Using Fishers exact test (which is better for small numbers) the following tables illustrates the $tcpO_2$ and ATP baselines in the patient cohort with diabetic foot ulcers (DFU).The tests were evaluated at a 95% significance level (p -value < 0.05).

Table 8.4 below compares absolute toe pressures to healed / non healed outcomes using a threshold of 30mmHg.

ATP's	>30	<30	TOTAL
HEALED	73	12	85
NON HEALED	34	5	39
			124

Table 8.4 Analysis of ATP's: Healed V's Non healed outcomes

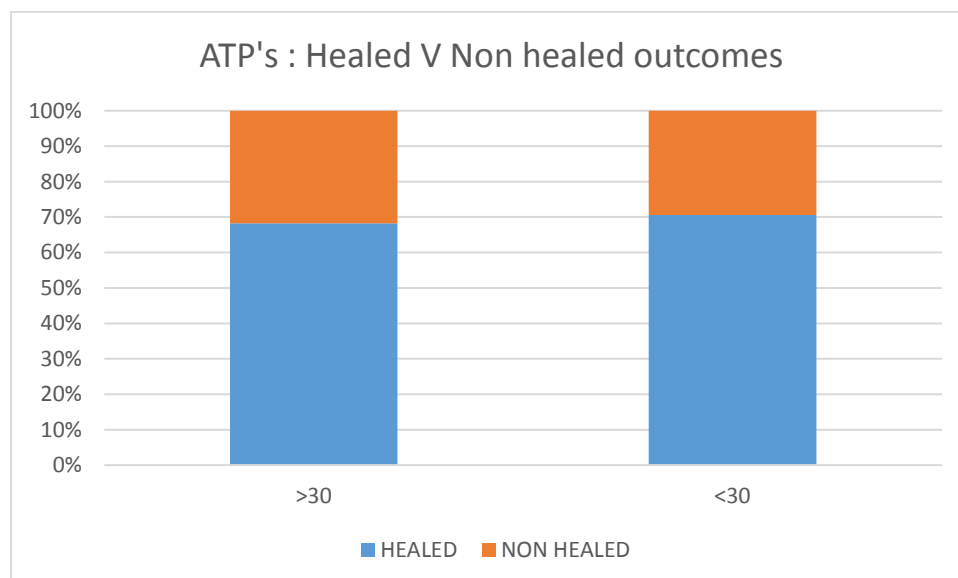

Figure 8.2 Comparisons of ATP's: Healed V Non healed outcomes

A Fishers exact test was performed to compare expected outcome and actual outcome in this test group. There was no significant difference ($p = 0.84$) in the ATP threshold of 30mmHg to indicate healed / non healed outcomes.

Table 8.5 below compares the $tcpO_2$ values to healed / non healed outcomes using a threshold of 40mmHg.

TCPO2	>40	<40	TOTAL
HEALED	53	32	85
NON HEALED	18	21	39
			124

Table 8.5 Analysis of $tcpO_2$: Healed V's Non healed outcomes

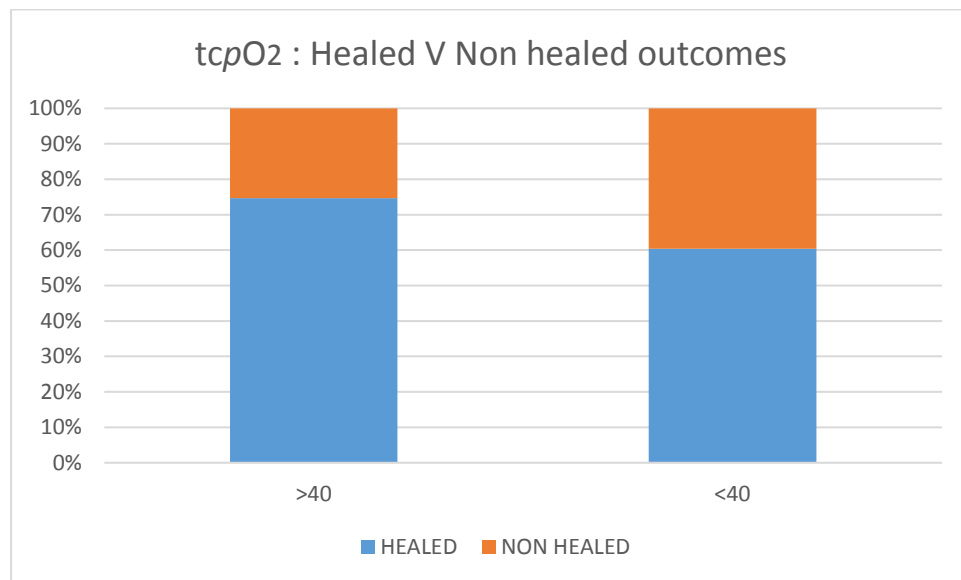

Figure 8.3 Comparisons of $tcpO_2$: Healed V Non healed outcomes

A Fishers exact test was performed to compare expected outcome and actual outcome in this test group. There was no significant difference ($p = 0.11$) in the $tcpO_2$ threshold of 40mmHg to indicate healed / non healed outcomes

It was decided to investigate if using a different $tcpO_2$ cut off value to the literature (40mmHg) would provide more diagnostic discrimination. The $tcpO_2$ test results were analysed at 35mmHg, 30mmHg, 25mmHg and 20mmHg with the threshold value of 30mmHg being the only value to be significantly statistically different.

Table 8.6 below compares $tcpO_2$ to healed / non healed outcomes

TCPO2	>30	<30	TOTAL
HEALED	69	16	85
NON HEALED	25	14	39
			124

Table 8.6 Analysis of $tcpO_2$: Healed V's Non healed outcomes

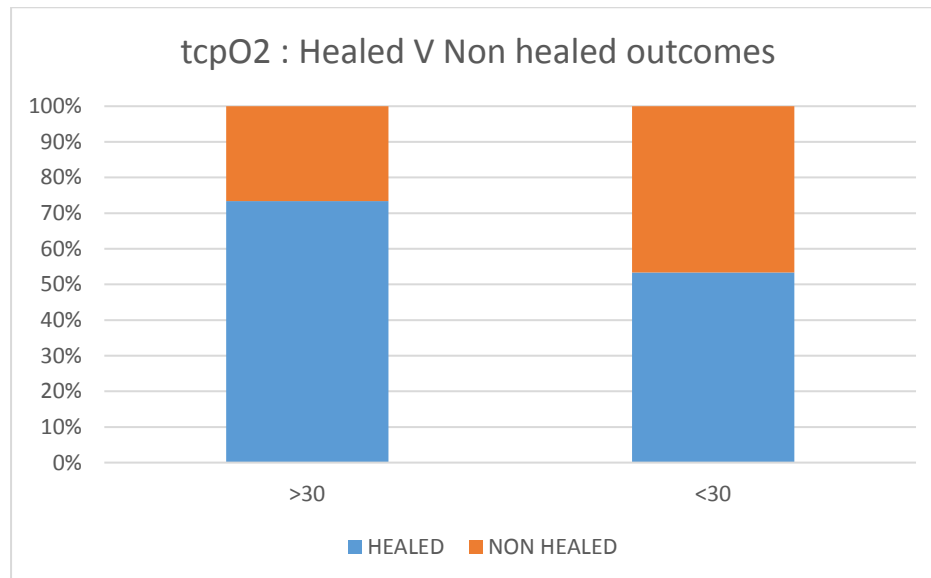

Figure 8.4 Comparisons of $tcpO_2$: Healed V Non healed outcomes

A Fishers exact test was performed to compare expected outcome and actual outcome in this test group. There was a significant difference ($p = 0.04$) in the $tcpO_2$ threshold of 30mmHg to indicate healed / non healed outcomes.

In further evaluating the significance of the reduction in $tcpO_2$ to 30mmHg, and to aid in the predication of outcomes, the sensitivity / specificity of the two tests were analysed. A $tcpO_2$ threshold of 30mmHg was used with an ATP threshold of 30mmHg also used.

The following table 8.7 details the breakdown of the tests for this analysis.

	Non Healed Disease present (Ischaemia)	Healed Disease absent (No Ischaemia)
$tcpO_2$ <30 Positive test	14 (a)	16 (c)
>30 Negative test	25 (b)	69 (d)
ATP < 30 Positive test	5 (a)	12 (c)
>30 Negative test	34 (b)	73 (d)

Table 8.7 Analyses of healed Vs non healed test numbers

For the purposes of analysis, a test was deemed to be "positive" if the pressure was < 30mmHg i.e. low pressure = ischaemia = expected non-healing. A test was deemed to be "negative" if the pressures was >30mmHg i.e. high pressure = not ischaemic = expected healing.

Test	Positive Predictive Value (PPV) $\frac{a}{a + c}$	Negative Predictive Value (NPV) $\frac{d}{b + d}$
$tcpO_2$	46.67%	73.40%
ATP	29.41%	68.22%

Table 8.8 Predictive values table (For a, b, c & d values refer to table 8.7 above)

Based on the breakdown of test numbers (124 diabetic ulcer tests), a test showing a $tcpO_2$ of greater than 30mmHg was deemed a "negative test" for ischaemia and indicated a 73% chance that the ulcer will heal (NPV). Conversely, a value of less than

30mmHg (a "positive test" for ischaemia indicated a 46% chance that the ulcer will fail to heal (NPV).

Likewise with the ATP tests, a test greater than 30mmHg was deemed a "negative test" and less than 30mmHg was deemed a "positive test". Both the negative (68%) and positive (29%) predictive values are lower in the ATP's when compared to $tcpO_2$.

The analysis of the data from Table 8.6 shows that a $tcpO_2$ level of 30mmHg is statistically significantly associated with subsequent healing/non-healing of ulcers ($p = 0.04$). A $tcpO_2$ of <30mmHg is associated with ulcer non-healing in 46% of cases. From this data $tcpO_2$ was a more accurate indicator of healing rather than ATP's, which had a non-healing predictive value of 29%.

8.4.2 Intervention tests

A large majority of diabetic foot ulcers are superficial and related primarily to neuropathy. These are managed by offloading and often do not require any vascular intervention.

Those that are ischaemic or neuroischaemic who may benefit from intervention were identified by clinical assessment (depth of ulcer, measures of osteomyelitis, pain, extent of tissue loss, healing response to offloading), measures of perfusion (tcpO₂, TBI), consideration of comorbidities and fitness for surgery, previous surgical history and known extent of vascular disease, anatomy of disease based on duplex, CT or angiogram, and patient preference.

There was no one factor that decided intervention. The decision may also have been revised/changed over time where, for example, the ulcer failed to respond or got deeper or more extensive despite therapy.

The group of non-healing patients who had an intervention (46) performed were analysed. These patients were subsequently followed to determine whether their ulcer had healed at the conclusion of the observation period. This cohort had pre and post test data collected using both modalities. Unfortunately a number of patients were excluded from the data analysis (23) due to a number of reasons – they had been discharged and not seen prior to leaving the hospital or before the end date of the study and/or they had a hallux or TMA amputation at the time of intervention meaning a post procedure TBI/ATP was not possible and they only had a tcpO₂ test performed.

The following table looks at the outcomes of the diabetic tests (23 tests) which had a revascularisation procedure in a bid to aid healing or prevent amputation.

	HEALED (12)		NON HEALED (11)	
	Pre	Post	Pre	Post
tcpO ₂	29	37	23	20
ATP	24	36	21	22
TBI	0.17	0.27	0.13	0.15

Table 8.9 Average measurements of diabetic ulceration pre and post intervention

Of the healed ulcers post intervention (12) there was an increase in both test results in comparison to the non healed interventions. Unfortunately for this study the numbers were deemed too small for any significant analysis to be performed.

The amputations levels where noted to be significant in this group in comparison to the non intervention group. The table below 8.10 details the number in each group.

	Non Intervention group (124)	Intervention group (23)
AKA	2	2
BKA	9	3
TMA	20	5
Toe	41	16
Total	72	26

Table 8.10 Amputation numbers

The percentage of proximal or major amputations in the non intervention group versus the intervention group are 15% and 19% respectively. Of note in the non intervention group 3 or 27% of these AKA/BKA’s were due to Charcot foot.

There was a larger incidence of distal or minor amputations in the intervention group with some having more than one amputation procedure during the treatment period.

8.5 Discussion

As in previous chapters it is known that smoking has a negative effect on the body, and affects both the micro and macro circulation, with a significant reduction shown in $tcpO_2$ and in the TBI test results in smokers. In the ulcer test group 27% of tests were noted to be smokers. Cessation is extremely important in the ulcer patients.

Student t tests carried out earlier in the chapter on all tests, show that the mean $tcpO_2$ and ATP's are significantly lower in those with ulceration versus those with no ulcers. This is understandable as ulceration may result from reduced perfusion and/or oxygenation to a limb resulting in abnormal test results. Ulceration is a multifactorial process with nutrient supply to the ulcerated area a key component which can be measured by either or both the microcirculation (Via ATP's) and the micro circulation (Via $tcpO_2$).

Further analysis in the chapter focused specifically on the ulcer test group only (section 8.3.2), and on the diabetic tests versus the non-diabetic tests – 75% of ulcers were diabetics. There was an indicated difference in the $tcpO_2$ in the diabetics versus the non-diabetics. There was no indicated difference in the ATP's in the diabetics versus the non-diabetics. Can it be suggested that $tcpO_2$ in the ulcerated diabetics offers alternative information? It is evident that although PAD is present in both the ulcerated diabetic and non-diabetic groups with no statistical difference noted between them, diabetic ulcers have better micro circulation than non diabetic ulcers. These results suggest that in the non-diabetic group the ulcers are the result of ischaemia due to their low TBI/ATP and $tcpO_2$ results, while in the diabetic group there are a greater proportion of neuropathic ulcers due to their higher TBI/ATP and $tcpO_2$ results. In patients with diabetes, the presence of neuropathy is also an important risk factor for the development of ulceration. Neuropathy can and frequently does occur without the presence of significant ischaemia. In the overall ulcer population – especially among the subset with diabetes - there may be a substantial number of patients with ulceration whose perfusion is normal or near normal. These results have shown that $tcpO_2$ can help identify patients with adequate perfusion in the presence of ulceration and therefore $tcpO_2$ is a valid alternative test in the absence of being able to perform a TBI/ATP in the diabetic patient.

Further statistical analyses focused on the diabetic ulcerations due to the large proportion of these in the study cohort (124). The main concern with ulceration is healing, how long it will take, if it will occur and if any interventions will be required. With regards to $tcpO_2$ measurements and the predication of wound healing outcomes, the consensus in published literature suggests that cut off values above 40mmHg are required for adequate wound healing and that those below 40mmHg have uncertain healing outcomes with a large majority of wounds failing to heal (Sheffield P.J. 2004, Yang C. et al. 2013). Analysis using 40mmHg in this study showed no significant difference in healing / non healing outcomes however other values were explored. This body of work would suggest that $tcpO_2$ with a threshold of 30mmHg is the best predictor of wound non-healing in this patient cohort. Statistical analysis has shown that there was a significant difference ($p = 0.04$) in $tcpO_2$ using the 30mmHg threshold with regards to healing / non healing outcomes. ATP's at 30mmHg and $tcpO_2$ at 40mmHg when analysed showed no significant difference in healing outcomes. Further evaluation of the 30mmHg threshold for $tcpO_2$ showed that $tcpO_2$ is more specific and sensitive in predicating wound healing versus ATP's (see figure 8.8).

There were 23 tests who had pre and post intervention tests for analysis, but for this study the numbers were too small for any significant statistical analysis purposes.

In summary this piece of work has illustrated that $tcpO_2$ can assist the treating physician in the prediction of wound healing and provides valuable information in the ulcerated patients. Importantly, the use of $tcpO_2$ (even in the presence of PAD) allows for the identification of a group of patients with adequate skin perfusion but with an active ulcer, suggesting the presence of an alternative cause. This additional information provides the attending medical professional with more options in the treatment of these ulcers i.e. in the presence of PAD, these patients ulcers may heal without revascularisation intervention. This information is unavailable in the absence of $tcpO_2$.

The $tcpO_2$ test has proven itself as a complimentary and valuable diagnostic test to a TBI / ATP. Given the complexity of many of the diabetic patients presenting to vascular clinics in recent times, it has become more difficult to treat ulceration successfully. This is a complex patient group, many of which are well known to the service. Amputations can be high in this cohort and in the absence of a hallux to record a TBI/ATP it is

essential to be able to rely on another testing modality to assess perfusion or ability to heal wounds. $tcpO_2$ has had a positive impact on their treatment and has proven to be a very beneficial test.

Chapter 9

Conclusion and Recommendations

9.0 Conclusion and Recommendations

Ulcers are very problematic for both the patient and healthcare provider with there being no one universally accepted test that can predict wound healing. The aim of this thesis was to audit results of a new test, (*tcpO₂*), that was introduced into the vascular laboratory service over a three year period.

Chapter 6 compared the risk factors of smoking, diabetes, hypertension and the use of statin therapy on the results of the two tests, TBI's and the newly introduced *tcpO₂*. The results from both tests were significantly reduced in smokers, with ATP's only reduced in those medicating for hypertension. This audit did not show any differences in the *tcpO₂* levels between those on medications (antihypertensive and statins) and those not. The interaction between tissue oxygenation and the use of antihypertensives and statin therapies are poorly studied and warrants further investigation.

This study did confirm that smoking is the one single risk factor that has a negative impact on both tests and as such affects both the micro and macro circulation and those patients with ulceration should be very strongly advised against its use.

Chapter 7 was a direct comparison between the results of both tests. A correlation coefficient of 0.49 was achieved, and although not a perfect correlation it is a positive one. Analysis of the data highlighted one cohort of most interest. This group (31% of total tests) contained the tests where the TBI's were reduced or abnormal but where there was a normal *tcpO₂* i.e. > 40mmHg. When this group is compared to the other group with both an abnormal TBI and also an abnormal *tcpO₂*, the number of interventions and amputations are significantly lower in the former i.e. the group with the normal *tcpO₂*. This implies that having a normal *tcpO₂* in the setting of PAD will lead to a higher level of ulcer healing and a lower incidence of intervention and amputation. It is therefore valid in these patients to take a "wait and see" approach rather than perform further immediate diagnostic tests, admissions or interventions. *tcpO₂* is a valuable and complimentary test to the traditional TBI. Further investigation of this group is highly recommended and was outside the scope of this study.

Chapter 8 examined diabetic ulcer healing outcomes. Of note there was a statistical difference in the *tcpO₂* tests only, between the diabetic and non diabetic patients. The

differing aetiology of ulceration in the diabetic and non-diabetic populations is an important consideration in the treatment of these patients. In the non-diabetes most ulcers are ischaemic and although some patients may have neuropathy, it is less common. In those with diabetes a significant number of ulcers are due to neuropathy, with little or no ischaemic component, so average perfusion values appear better as was seen in section 8.3.2. A comprehensive assessment of these patients including the evaluation of and documentation of their neurological status would be very informative, but in this instance was beyond the scope of the vascular laboratory assessments carried out and this data was not available for the purpose of this study.

Finally further statistical analysis in the chapter focused on the healing outcomes of the diabetic ulcers. It can be suggested that a threshold level of 30mmHg is the best predictor of wound healing /non-healing in this patient cohort. Further evaluation of the 30mmHg threshold for $tcpO_2$ showed that $tcpO_2$ is more specific and sensitive in predicating wound healing versus ATP's.

In conclusion this thesis has led to a number of observations:

- Smoking is the single risk factor proven to effect both $tcpO_2$ and ATP's, and should be strongly advised against in all ulcer patients.
- The use of $tcpO_2$ and its comparison to TBI's, has led to the identification a previously unknown group of patients, where the TBI result was reduced but the $tcpO_2$ result was normal. This group had significantly less interventions and amputations.
- Neuropathy is a significant factor when dealing with diabetic patients with ulceration, which vascular physiologists may not always be aware of the importance of.
- A $tcpO_2$ threshold level of 30mmHg is the best predictor of wound healing in this diabetic ulcer patient cohort. It can be suggested that $tcpO_2$ is more specific and sensitive in predicating wound healing versus ATP's

Recommendations following this thesis are as follows:

- Further detailed analysis of the group with reduced TBI's and a normal $tcpO_2$ test result is recommended.
- Although it is widely recommended that a neurological lower limb assessment of diabetic ulcer patients on initial presentation should be performed, and that there should be widespread active multidisciplinary management programmes in place to focus on education, prevention and early intervention in the diabetic population, there is a variation in practice across Ireland.
- $tcpO_2$ is a valuable and complimentary test to the traditional TBI and should be a considered test in all patients who present with an ulcer. Given the complexity of the diabetic patient cohort $tcpO_2$ is an important and beneficial test which should be performed when deciding on treatment.
- Subsequent to the completion of this body of work and resulting indication of the usefulness of $tcpO_2$ as a valuable test, the laboratory protocol has now evolved to include a simultaneous trunk $tcpO_2$ measurement. This allows a systemic factor to be considered via the calculation of an RPI (Regional Perfusion Index). The ability of this RPI to better predict healing potential is currently being investigated in Tallaght University Hospital.

References:

References:

Al Mahameed A. (2009) Peripheral Arterial Disease. *Cleveland Clinic Center for Continuing Education*.

Allen J. (2007) Photoplethysmography and its application in clinical physiological measurement. *Physiol Meas*,28(3), pp. R1-39.

Balanda, K. P., Barron, S., Fahy, L. and McLaughlin, A. (2010) Making Chronic Conditions Count: Hypertension, Stroke, Coronary Heart Disease, Diabetes. *The Institute of Public Health*.

Bourne, R. R., Stevens, G. A., White, R. A., Smith, J. L., Flaxman, S. R., Price, H., Jonas, J. B., Keeffe, J., Leasher, J., Naidoo, K., Pesudovs, K., Resnikoff, S., Taylor, H. R. and Vision Loss Expert, G. (2013) Causes of vision loss worldwide, 1990-2010: a systematic analysis. *Lancet Glob Health*,1(6), pp. e339-49.

Chronic Conditions Hub (2016) Diabetes.

Circulation Foundation (2016) Leg Ulcers.

Coman I.M. Popescu B.A. (2015) Shigeo Satomura: 60 years of Doppler ultrasound in medicine. *Cardiovascular Ultrasound*,13, pp. 48.

Coppola G. Novo S. (2007) Statins and peripheral arterial disease: effects on claudication, disease progression, and prevention of cardiovascular events. *Arch Med Res*,38(5), pp. 479-88.

Danaei, G., Finucane, M. M., Lu, Y., Singh, G. M., Cowan, M. J., Paciorek, C. J., Lin, J. K., Farzadfar, F., Khang, Y. H., Stevens, G. A., Rao, M., Ali, M. K., Riley, L. M., Robinson, C. A., Ezzati, M. and Global Burden of Metabolic Risk Factors of Chronic Diseases Collaborating, G. (2011) National, regional, and global trends in fasting plasma glucose and diabetes prevalence since 1980: systematic analysis of health examination surveys and epidemiological studies with 370 country-years and 2.7 million participants. *Lancet*,378(9785), pp. 31-40.

Department of Health (2014) Varadkar and Lynch secure modest Budget increase in health service funding for first time in 7 years. in *Budget 2015 brings stability but savings still necessary in year ahead*.

Dewland T.A., Soliman, E. Z., Davis, B. R., Magnani, J. W., Yamal, J. M., Piller, L. B., Haywood, L. J., Alonso, A., Albert, C. M. and Marcus, G. M. (2016) Effect of the Antihypertensive and Lipid-Lowering Treatment to Prevent Heart Attack Trial (ALLHAT) on Conduction System Disease. *JAMA Intern Med*,176(8), pp. 1085-92.

Diabetes Ireland (2016) Are you at risk of Diabetes?

Emerging Risk Factors, C., Sarwar, N., Gao, P., Seshasai, S. R., Gobin, R., Kaptoge, S., Di Angelantonio, E., Ingelsson, E., Lawlor, D. A., Selvin, E., Stampfer, M., Stehouwer, C. D., Lewington, S., Pennells, L., Thompson, A., Sattar, N., White, I. R., Ray, K. K. and Danesh, J. (2010) Diabetes mellitus, fasting blood glucose concentration, and risk of vascular disease: a collaborative meta-analysis of 102 prospective studies. *Lancet*,375(9733), pp. 2215-22.

Fife, C. E., Smart, D. R., Sheffield, P. J., Hopf, H. W., Hawkins, G. and Clarke, D. (2009) Transcutaneous oximetry in clinical practice: consensus statements from an expert panel based on evidence. *Undersea Hyperb Med*,36(1), pp. 43-53.

Ginzel K.H. (2016) Have You Ever Wondered What's In a Cigarette? *Quit Smoking Support*.

Health Service Executive (2015) Cigarette Smoking Prevalence in Ireland.

Health Service Executive (2016) Smoking - The Facts.

Heart Protection Study Collaborative Group (2002) MRC/BHF Heart Protection Study of cholesterol lowering with simvastatin in 20,536 high-risk individuals: a randomised placebo-controlled trial. *Lancet*,360(9326), pp. 7-22.

International Diabetes Federation (2013) *IDF Diabetes Atlas*.

International Diabetes Federation (2015) *IDF Diabetes Atlas*.

IrishHealth (2003) The diabetes epidemic.

James P. A., Oparil, S. and Carter, B. L. (2014) 2014 evidence-based guideline for the management of high blood pressure in adults: Report from the panel members appointed to the eighth joint national committee (jnc 8). *JAMA*,311(5), pp. 507-520.

Lee C.L. Chang W.D (2013) The effects of cigarette smoking on aerobic and anaerobic capacity and heart rate variability among female university students. *International Journal of Women's Health*,5, pp. 667-679.

Lee Y.N., Kim H.S., Kang J.A. and Han S.K. (2014) Can macrocirculation changes predict nonhealing diabetic foot ulcers? *Journal of wound, ostomy and continence nursing*,Sep-Oct(41), pp. 430-5.

Lumley T., Diehr P., Emerson S., Chen L. (2002) The importance of the Normality assumption in large public health data sets. *Annual review of public health* (23), pp. 151-69

Marso S. P. Hiatt W. R. (2006) Peripheral arterial disease in patients with diabetes. *J Am Coll Cardiol*,47(5), pp. 921-9.

Nadel J.A. Comroe J.H. (1961) Acute effects of inhalation of cigarette smoke on airway conductance. *J Appl Physiol*,16, pp. 713-6.

Nason G.J., Strapp, H., Kiernan, C., Moore, K., Gibney, J., Feeley, T. M., Egan, B. and Tierney, S. (2012) The cost utility of a multi-disciplinary foot protection clinic (MDFPC) in an Irish hospital setting. *Irish Journal of Medical Science*, 201(2), pp. notIr J Med Sci.

National Clinical Guideline Centre (2011) National Institute for Health and Clinical Excellence: Guidance. in *Hypertension: The Clinical Management of Primary Hypertension in Adults: Update of Clinical Guidelines 18 and 34*, London: Royal College of Physicians (UK) National Clinical Guideline Centre.

National Institute for Health Care Excellence (2016a) *Cardiovascular disease: risk assessment and reduction, including lipid modification*. NICE guidelines [CG181]: NICE.

National Institute for Health Care Excellence (2016b) *Diabetic foot problems: prevention and management*. NICE guidelines [NG19] NICE.

National Institute of Diabetes and Digestive and Kidney Diseases (2013) Nerve Damage (Diabetic Neuropathies). *Preventing Diabetes Problems*.

National Institute of Diabetes and Digestive and Kidney Diseases (2014) Kidney Disease of Diabetes. *Health Topics*, 14–3925.

National Institute of Diabetes and Digestive and Kidney Diseases (2016) *Causes of Diabetes*, Available: <https://www.niddk.nih.gov/-/media/Images/Diabetes/Pancreatic-islet.jpg?la=en&hash=4FD03969A39ECB9A5501FC44B7E2FA8097A86FA1> 2016].

National Institute of Health (2016) Who Is at Risk for Atherosclerosis? *National Heart Lung and Blood Institute*.

Nolan, J. J., O'Halloran, D., McKenna, T. J., Firth, R. and Redmond, S. (2006) The cost of treating type 2 diabetes (CODEIRE). *Ir Med J*, 99(10), pp. 307-10.

Norgren L., Hiatt, W. R., Dormandy, J. A., Nehler, M. R., Harris, K. A. and Fowkes, F. G. R. (2007) Inter-Society Consensus for the Management of Peripheral Arterial Disease (TASC II). *Journal of Vascular Surgery*,45(1), pp. S5-S67.

Norris, K., Bourgoigne, J., Gassman, J., Hebert, L., Middleton, J., Phillips, R. A., Randall, O., Rostand, S., Sherer, S., Toto, R. D., Wright, J. T., Jr., Wang, X., Greene, T., Appel, L. J. and Lewis, J. (2006) Cardiovascular outcomes in the African American Study of Kidney Disease and Hypertension (AASK) Trial. *Am J Kidney Dis*,48(5), pp. 739-51.

Sheffield P.J. (2004) Wound Care Practice. in A.P.S, S., E, C. and M.D, F., (eds.): Best Publishing Company. pp. 814

Silverstein P. (1992) Smoking and wound healing. *The American Journal of Medicine*,93(1), pp. S22-S24.

The Institute of Public Health (2006) Making diabetes count. A systematic approach to estimating population prevalence on the island of Ireland in 2005.

The Institute of Public Health (2007) Making diabetes count. What does the future hold? *A systematic approach to forecasting population prevalence on the island of Ireland in 2010 and 2015.*

The Society for Vascular Technology of Great Britain & Ireland (2001) *Vascular Laboratory Practice*, England:Institute of Physics and Engineering in Medicine.

U.S. Department of Health Human Services (2014) *2014 Surgeon General's Report. The Health Consequences of Smoking—50 Years of Progress: Centers for Disease Control and Prevention.*

World Health Organization (1999) *Definition, diagnosis and classification of diabetes mellitus and its complications.* Geneva: WHO.

World Health Organization (2013) *Diagnostic criteria and classification of hyperglycaemia first detected in pregnancy*. Diabetes Programme.

Yang C., Weng H., Chen L., Yang H., Luo G., Mai L., Jin G. and Yan L. (2013) Transcutaneous oxygen pressure measurement in diabetic foot ulcers: mean values and cut-point for wound healing. *Journal of wound, ostomy and continence nursing*,40(6).

Zimmet, P., Alberti, K. G. and Shaw, J. (2001) Global and societal implications of the diabetes epidemic. *Nature*,414(6865), pp. 782-7.

Zwiebel W.J. and Pellerito J. (2000) *Introduction to Vascular Ultrasonography*, 4th ed.

Figure references (last accessed June 2016)

2.1

<http://www.niddk.nih.gov/health-information/health-topics/Diabetes/causes-diabetes/Pages/index.aspx>

2.2

A) <http://www.footandanklecg.com/diabetic-foot-ulcers.html>

B) J. Monroe Laborde, MD, MS, Is Tendon Lengthening The Best Treatment For Diabetic Foot Ulcers? Podiatry Today, Volume 25 - Issue 5 - May 2012

2.3

<http://www.vhcephysianguroup.com/cardiology/conditions/vascular-disease/carotid-artery-disease/>

3.1

https://www.wpclipart.com/medical/anatomy/skin/skin_diagram.png.html

3.2

http://www.homepages.ucl.ac.uk/~zchab6a/v2/ssm_yr1_1/heartanatomy.htm

3.3

<https://quizlet.com/11250340/blood-vessels-flash-cards/>

3.4

<https://quizlet.com/11250340/blood-vessels-flash-cards/>

3.5

<https://www.studyblue.com/notes/note/n/arterial-supply-to-the-foot/deck/5184701>

3.6

<http://biology.about.com/od/anatomy/ss/microcirculation.htm>

4.1

https://www.google.ie/search?q=the+doppler+effect&biw=1280&bih=683&source=lnms&tbm=isch&sa=X&sqi=2&ved=0ahUKEwjS6fSqvLTLAhVBKg8KHbXQBSIQ_AUIBigB&dpr=1#imgrc=_Bvq8hf6VXhVaM%3A

4.2

https://www.google.ie/search?q=angel+of+interrogation+between+doppler+beam+and+direction+of+blood+flow&biw=1440&bih=794&source=lnms&tbm=isch&sa=X&ved=0ahUKEwia_u_80bHPAhVoD8AKHXHsB9QQ_AUIBigB&safe=active&ssui=on#imgdii=9nchWqFL1QSiYM%3A%3B9nchWqFL1QSiYM%3A%3BFqE2rrHnxYVVbM%3A&imgrc=9nchWqFL1QSiYM%3A

4.5

<http://www.intechopen.com/books/adaptive-filtering-applications/adaptive-filtering-by-non-invasive-vital-signals-monitoring-and-diseases-diagnosis>

4.7

https://en.wikipedia.org/wiki/Clark_electrode#/media/File:Clark_Electrode.png