

2006-1

Holographic Recording in Nanoparticle-doped Photopolymer

Izabela Naydenova

Technological University Dublin, izabela.naydenova@tudublin.ie

Hosam Sherif

Technological University Dublin

Svetlana Mintova

University of Munich

Suzanne Martin

Technological University Dublin, suzanne.martin@tudublin.ie

Vincent Toal

Technological University Dublin, vincent.toal@tudublin.ie

Follow this and additional works at: <https://arrow.tudublin.ie/cieocon2>



Part of the [Condensed Matter Physics Commons](#), and the [Optics Commons](#)

Recommended Citation

Naydenova, I. et al. (2006) Holographic recording in nanoparticle-doped photopolymer. *SPIE proceedings of the International Conference on Holography, Optical Recording and Processing of Information, V 6252*, pp.45-50, doi:10.1117/12.676503

This Conference Paper is brought to you for free and open access by the Centre for Industrial and Engineering Optics at ARROW@TU Dublin. It has been accepted for inclusion in Conference Papers by an authorized administrator of ARROW@TU Dublin. For more information, please contact yvonne.desmond@tudublin.ie, arrow.admin@tudublin.ie, brian.widdis@tudublin.ie.



This work is licensed under a [Creative Commons Attribution-Noncommercial-Share Alike 3.0 License](#)



2005-01-01

Holographic recording in nanoparticle-doped photopolymer

Izabela Naydenova

Dublin Institute of Technology, izabela.naydenova@dit.ie

Hosam Sherif

Dublin Institute of Technology

Svetlana Mintova

University of Munich

Suzanne Martin

Dublin Institute of Technology, suzanne.martin@dit.ie

Vincent Toal

Dublin Institute of Technology, vincent.toal@dit.ie

Recommended Citation

I. Naydenova, H. Sherif, S. Mintova, S. Martin, V. Toal, "Holographic recording in nanoparticle-doped photopolymer", SPIE proceedings of the International Conference on Holography, Optical Recording and Processing of Information, V 6252, 45-50, 2006. doi:10.1117/12.676503

This Conference Paper is brought to you for free and open access by the Centre for Industrial and Engineering Optics at ARROW@DIT. It has been accepted for inclusion in Articles by an authorized administrator of ARROW@DIT. For more information, please contact yvonne.desmond@dit.ie, arrow.admin@dit.ie.



Holographic recording in nanoparticle-doped photopolymer

I. Naydenova^{a*}, H. Sherif^a, S. Mintova^b, S. Martin^a, V. Toal^a

^aCentre for Industrial and Engineering Optics, Dublin Institute of Technology,
Kevin Street, Dublin 8, Ireland

^bDepartment of Chemistry, University of Munich (LMU), 81377 Munich, Germany

ABSTRACT

A nanoparticle-doped acrylic photopolymer is characterised as a material for holographic recording. The influence of nanoparticles on the photopolymer dynamic range, dynamics of recording, temporal stability and mechanical stability in terms of shrinkage has been studied. The dynamics of recording and the temporal stability are investigated by real time monitoring of the build up of diffraction gratings of spatial frequencies of 200 to 2000 1/mm. The shrinkage has been characterised by recording slanted transmission gratings and observation of the change in the Bragg angle.

Keywords: holography, photopolymers, inorganic nanoparticles, shrinkage of photopolymers.

1. INTRODUCTION

Target characteristics of photopolymer materials for optical applications are high sensitivity and resolution, good optical quality, large dynamic range, temporal and dimensional stability, and low scattering. In addition to all these features self-development and the relatively low cost make the photopolymers an attractive candidate for holographic applications, such as holographic memories, holographic optical elements and spectroscopic devices. Acrylamide based photopolymer systems are known to exhibit most of the above mentioned characteristics¹⁻³. A main drawback of these systems is their relatively large shrinkage, observed after photopolymerisation of the material⁴. In the present paper we adopted a previously proposed approach⁵⁻⁷ for suppressing the level of shrinkage by incorporation of an inorganic nanoparticle component. In addition we demonstrate that the photopolymer containing porous Si-MFI nanoparticles has improved diffraction efficiency at spatial frequencies of 1000 1/mm and 2000 1/mm.

2. THEORY

2.1. Optical recording in photopolymers

The basic formulation of a dry photopolymer system is a photoinitiator and a monomer that are dispersed in a binder matrix. In most of the photopolymers the photoinitiator system consists of at least two components –a sensitizing dye and an electron donor¹⁻³. The desired operational wavelength range can be easily optimised by the choice of the sensitizing dye. The process of photopolymerisation can be divided into three steps. The first step, the initiation of the photopolymerisation, consists of initial production of free radicals after a photon has been absorbed by the sensitizing dye and the excited dye molecule has interacted with the electron donor. The initiation is followed by chain propagation during which free radicals and monomer molecules interact and the polymer chains grow. During the last step, termination, chain growing stops due to disproportionation or combination reactions. The molecular refractivity changes during the polymerization reaction. In addition, when the illuminating pattern is spatially inhomogeneous, a diffusion of some of the components of the photopolymer system can occur due to the creation of a concentration gradient. This leads to space modulation of the material's density that follows the original light pattern. As a result the local refractive index of the photopolymer changes and a spatial modulation of refractive index occurs.

2.2. Inorganic nanoparticle dopant - lower shrinkage and larger dynamic range

* izabela.naydenova@dit.ie

The incorporation of additional components with considerably different refractive index from that of the origin photopolymer was proposed first by Dahr et al⁸. If the non-reactive component can be spatially redistributed during the holographic recording, and it has the appropriate refractive index, this can lead to significant improvement in the ultimate refractive index modulation. Suzuki et al⁵⁻⁷ implemented this idea by using TiO₂ and SiO₂ nanoparticles in methacrylate photopolymers. They demonstrated that in the presence of nanoparticles the dynamic range is significantly improved and the shrinkage in their photopolymer is suppressed. Recently⁹ they were able to present evidence of nanoparticles redistribution using the running fringe method of Kondilenko¹⁰. The increased refractive index modulation in the system containing SiO₂ is explained by diffusion of nanoparticles from the bright to dark fringe areas⁹. The proposed process is in the opposite direction to monomer diffusion, which is known to occur from dark to bright fringe.

3. EXPERIMENTAL

3.1. Materials

The inorganic nanoparticles used in this study are porous Si-MFI crystals prepared from clear precursor solutions with molar composition: 9TPAOH: 25SiO₂: 530H₂O: 100EtOH. Tetraethoxysilane [TEOS, 98%] (Aldrich) tetrapropylammonium hydroxide [TPAOH] (Aldrich) and doubly distilled water were used as starting materials. The precursor solution was aged on an orbital shaker (180 rpm) at room temperature from 24 h to 30 days. Further crystallization was carried out in polypropylene bottles at 90°C for up to 6 h. Prior to use, the resulting nano-sized crystals were separated from the parent liquid by two-steps centrifugation at 20,000 rpm for 1 h, and redispersed in an ultrasonic bath in doubly distilled water for 2 h.

Dynamic light scattering (Fig.1) was used to determine the mean hydrodynamic diameter of the crystalline zeolite particles (ALV-NIBS/HPPS) upon hydrothermal treatment. The back scattering geometry (scattering angle 173°, HeNe laser with 3 mW output power at 632.8 nm wavelength) permitted measurements at high sample concentration, because a complete penetration of the incident light through the sample was not required.

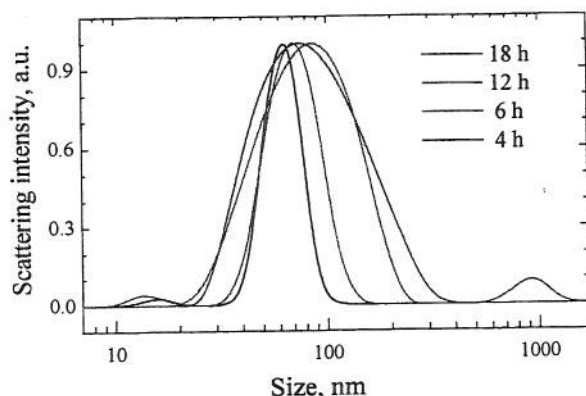

Fig. 1 Particle size distribution of colloidal Si-MFI synthesized from pure silica precursor solution.

HRTEM micrographs were recorded using a Philips CM 20 FEG TEM operated at 200 kV (Fig.2).

The composition of the basic photopolymer was prepared previously described [1]. It consisted of a polyvinyl alcohol binder, two monomers - acrylamide and N,N-methylenebisacrylamide, Erythrosin B as a sensitising dye and triethanolamine as an initiator. The photopolymer system is water-soluble. All components were mixed on a magnetic stirrer for 30 min. Zeolite suspensions with solid content 1.5 wt. % were mixed with the photopolymer. In addition, samples with a concentration of nanoparticles from 0.3 wt.

to 1.2 wt. % were prepared as well. Taking into account that before the drying process approximately 85 % of the photopolymer solution is water, most of which evaporates during the drying process, one would expect that the actual concentration of the nanoparticles in the dry photopolymer layer would be much higher. The dye was added at the first stage of photopolymer preparation and mixed for 5 min. The solution was then spread on 50 x 50 mm glass plates. The samples were dried for 24 - 36 hours. Depending on the amount of the photopolymer solution used, layers with thickness between 20 and 80 μm were obtained. In order to prepare thicker layers, 20 % instead of 10 % PVA solution was used. Layers with maximum thickness of approximately 1 mm were prepared in Petri dishes after drying for 1 week. In order to keep the same optical density as that of the thin layers, 0.3 OD, the dye concentration was adjusted in every case.

3.2. Experimental set-up

3.2.1. Real time measurement of the diffraction efficiency

The dynamics of recording were studied by measuring the light intensity in the first order of diffraction of a transmission grating. The grating was recorded using a Nd:YVO₄ laser (Verdi 05) λ=532 nm. Recording times were from

100 to 120s and the total recording intensity was varied between 5 and 100 mW/cm². A He - Ne laser, $\lambda=633\text{nm}$, was used for real time observation of the grating formation. The photopolymer absorption is negligible at 633nm and the investigated gratings are considered as phase gratings, i.e. due to photoinduced change in the refractive index. Transmission gratings at different spatial frequencies in the range 200 - 2000 l/mm were recorded. Diffracted intensities in the +1 order were recorded using a Newport Model 840 optical power meter. A Laplace Instruments data acquisition system was used to transfer the signal from the photodetector to a computer. The data were recorded using 20 ms time resolution. The refractive index modulation Δn , at higher spatial frequencies where the gratings can be considered as being thick volume gratings, was calculated using the measured diffraction efficiency η according to Kogelnik's theory¹¹ according to the following formula:

$$\Delta n = \frac{\lambda \cos \theta \cdot \text{Arcsin} \sqrt{\eta}}{\pi \cdot d}, \quad (1)$$

where d is the grating's thickness, λ - reading beam wavelength and θ - reading beam incidence angle.

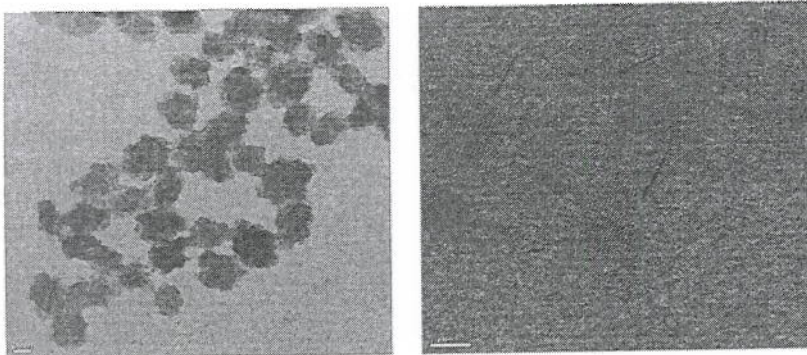

Fig. 2 Si-MFI nanoparticles obtained after 2 h hydrothermal synthesis of pure silicate precursor solutions. Scale bar is 20 nm (a) and 10 nm (b).

3.2.2. Shrinkage investigation

A preliminary study of the photopolymer shrinkage was carried out by recording a single slanted holographic grating in a photopolymer layer. A slant angle, between the photopolymer layer normal and the bisector of the recording beams of 6° was used.

This is a relatively small slant angle; for more detailed characterization of the shrinkage slant angles up to 40° have to be used. Restrictions originating from the present geometry of the optical set-up (Fig. 3) didn't allow recording at higher slant angles. The spatial frequency of the grating used to estimate the material's shrinkage was 1300 lines/mm. An exposure energy of 8 mJ/cm² was delivered from an Argon ion laser operating at 514 nm. Once the grating was recorded, it was probed at the same wavelength of 514 nm and attenuated intensity of 80 $\mu\text{J}/\text{cm}^2$. The dependence of the intensity of the diffracted light on the incident angle was measured and the level of shrinkage was determined from the angular shift in the read-out angle from the exact Bragg angle of recording.

4. RESULTS AND DISCUSSION

4.1. Study of the dynamics of recording at different spatial frequencies

The dynamics of recording were studied at 200, 1000 and 2000 l/mm spatial frequencies. The results of recording at a low spatial frequency of 200 l/mm are shown in Fig. 4. It is seen that at this spatial frequency no improvement of the refractive index at saturation was achieved when the recording intensity was 5 mW/cm². The highest diffraction efficiency was achieved for the reference layer without nanoparticles. The situation was reversed when the recording intensity was increased to 20 mW/cm². In this case the diffraction efficiency in the layers containing Si-MFI nanoparticles was higher than that of the reference sample. The highest improvement of 43 % was observed for the maximum concentration of nanoparticles, i.e., about 1.2 wt. %. This result implies that at such a low spatial frequency, redistribution of nanoparticles occurs only when the recording intensity is high. As the refractive index of the nanoparticles is significantly lower ($n_{\text{sil}}=1.21\div 1.39$) than the refractive index of the photopolymer layer ($n_{\text{ph}}=1.5$) a positive effect on the final refractive index modulation could be expected when the nanoparticles are excluded from the bright fringe areas and relocated in the corresponding dark fringe areas. Such diffusion process is in the opposite direction to the monomer diffusion, which takes place from dark to bright fringe areas and is mainly driven by monomer concentration gradient. At the same time such rearrangement of nanoparticles will be facilitated by diffusion of oligomers and/or short polymer chains from bright to dark fringe areas^{12, 13}.

One explanation for the observed improvement of the diffraction efficiency of the nanoparticle-containing photopolymers at high intensity of recording could be that at higher intensity the number of shorter polymer chains is expected to be higher and consequently a larger number of oligomers and/or short polymer chains would diffuse and

sweep the nanoparticles in the desired direction. Another possible explanation could be that the presence of porous silic nanoparticles slows down diffusion and restricts loss of short polymer chains¹³ into dark fringe areas thereby improving the diffraction efficiency. Future work on the influence of Si-MFI on the diffusion properties of the photopolyme system will bring more light into this matter.

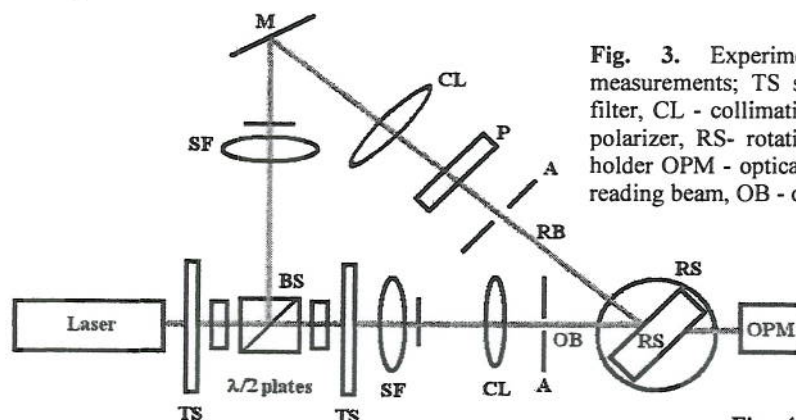

Fig. 3. Experimental set-up for shrinkage measurements; TS stands for shutter, SF -spatia filter, CL - collimating lens, BS - beam splitter, P polarizer, RS- rotational stage, PS - photopolyme holder OPM - optical power meter, M- mirror, RB reading beam, OB - object beam, and A - aperture.

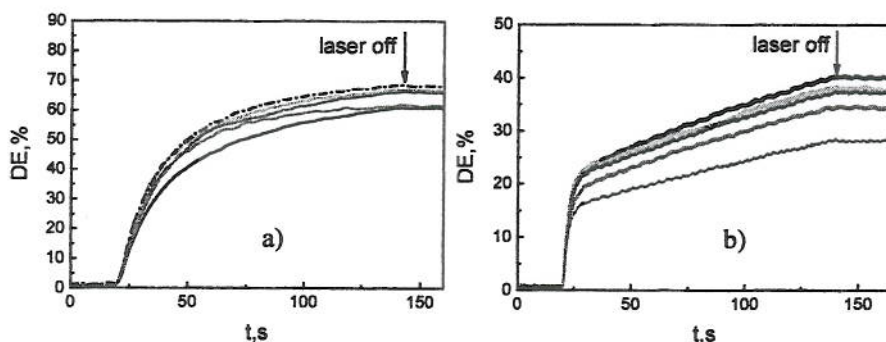

Fig. 4 Dynamics of recording in 6 μm thick layers at spatial frequency o 200 l/mm. Recording intensity is : mW/cm² a) and 20 mW/cm² b). The concentrations of the Si-MFI in photopolymer solution are as follows 0% w/w (dash-dotted black), 0.3 wt. % (solid grey), 0.6 wt. % (solid dark grey), 0.9 wt. % (solid light grey), 1.2 wt. % (solid black).

efficiency at 20 mW/cm², the overall diffraction efficiency at this intensity of recording is smaller than that when the gratings are recorded at 5 mW/cm². This is in line with the normal behaviour of a material under high intensity exposure. High intensity produces high termination rates and therefore short chains, and low diffraction efficiency for the same exposure. The limited improvement of the diffraction efficiency at 20 mW/cm² implies that if a redistributor of nanoparticles takes place only a small number of particles are redistributed at this low spatial frequency of recording. The positive effect on the refractive index modulation due to redistribution of Silicalite 1 nanoparticles will compete with the effect of unbalanced polymerisation and diffusion rates during the holographic recording. The significance of the balance between the polymerisation and diffusion rates is well explained by theoretical models for holographic recording in photopolymers¹⁴⁻¹⁷. A decrease of the overall diffraction efficiency with the increase of the recording intensity was observed in all samples; an example for a case with the highest Si-MFI concentration is shown in Fig 5. Recording at intensities from 5 to 100 mW/cm² in layers containing 1.2 wt. % Si-MFI nanoparticles shows a pronounced decrease in the overall refractive index modulation with increase of the recording intensity. The picture is changed considerably when the recording was performed at 1000 l/mm. The improvement of the ultimate refractive index modulation is much more pronounced at this spatial frequency. The results are presented in Fig. 6. It was observed that the increase of the concentration of Si-MFI nanoparticles leads to an increase of the saturated value of the refractive index modulation. Recording at a spatial frequency of 2000 l/mm has shown that there is an optimum concentration of Si-MFI nanoparticles. As it is seen in Fig. 7 when a very small amount of nanoparticles is added, there is an increase of the refractive index modulation at saturation. Further increase of the Si-MFI concentration decreases this effect. We don't know the exact origin of this observation, but one possible explanation could be that at this high spatial frequency of recording, where the fringe spacing is 500 nm, if any aggregation or clustering of nanoparticles occurs and as the size of a single nanoparticle is approximately 60nm at some point the size of the clusters may approach the size of the fringes. This would decrease the contrast of the refractive index modulation profile and decrease the ultimate diffraction efficiency.

It must be noticed that although the presence of nanoparticles improves the final diffractor

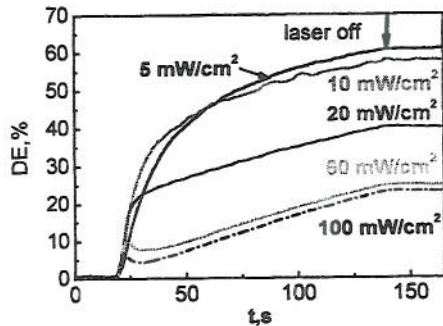

Fig. 5 Dynamics of recording in 60 μm layers at 200 l/mm. Si-MFI concentration is 1.2 wt. %; recording intensity is 5 (solid black), 10 (solid grey), 20 (solid dark grey), 50 (solid light grey) and 100 mW/cm^2 (dotted black curve).

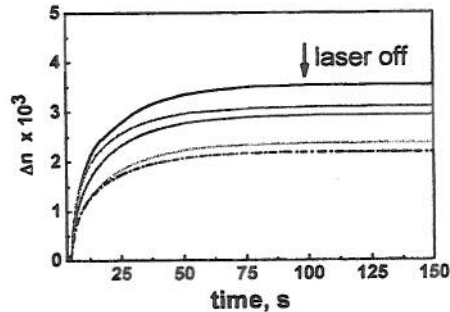

Fig. 6 Dynamics of recording in 40 μm thick layers at spatial frequency of 1000 l/mm. Recording intensity is 5 mW/cm^2 . The concentrations of the Si-MFI nanoparticles are as follows: 0 wt. % (dash-dotted black), 0.3 wt. % (solid light grey), 0.6 wt. % (solid dark grey), 0.9 wt. % (solid grey), 1.2 wt. % (solid black).

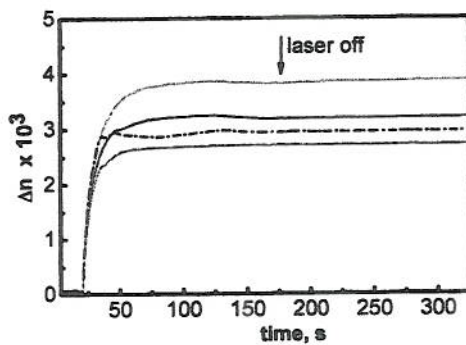

Fig. 7 Dynamics of recording in 60 μm thick layers at spatial frequency of 2000 l/mm and recording intensity is 10 mW/cm^2 . The concentrations of Si-MFI 1 nanoparticles are as follows: 0 wt. % (dash-dotted black), 0.3 wt. % (solid light grey), 0.6 wt. % (solid dark grey), 0.9 wt. % (solid grey).

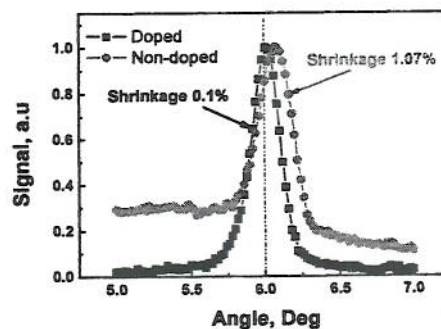

Fig. 8 Angular selectivity curves for Si-MFI-containing (0.9 wt. %) photopolymer thick sample ($\sim 650 \mu\text{m}$) (black) and non-doped sample (grey).

4.2. Temporal stability

The temporal stability of the recorded gratings was studied by measuring the diffraction efficiency after the samples were stored at ambient temperature, humidity and light conditions. It was observed that after more than 30 days the diffraction efficiency of these samples was changed by less than 5 %. The monitoring of the samples diffraction efficiency with time of storage is in progress.

4.3. Study of shrinkage

The study of the level of shrinkage shows that the incorporation of Si-MFI nanoparticles leads to a significant decrease of the shift of the angular selectivity curve (see Fig. 8). The fractional change Δd in a material with thickness d_0 can be obtained by knowing the initial slant angle of the grating (ϕ_0) and the final slant angle (ϕ_1), i.e.:

$$\Delta d = d_0 [\tan \phi_1 / \tan \phi_2 - 1] \quad (2)$$

It was also observed that there is dependence between the level of shrinkage and the sample thickness of the examined layers; the percentage shrinkage increases as the sample thickness decreases. In all of the cases the percentage shrinkage of the layers containing nanoparticles was significantly lower than in the pure photopolymer samples. Continuous studies of the shrinkage properties at larger slant angles and shrinkage thickness dependence are in progress.

CONCLUSIONS

The study of the holographic properties of acrylamide-based photopolymer doped with Si-MFI nanoparticles shows a significant increase of material's dynamic range at spatial frequencies of recording between 1000 and 2000 l/mm. This effect could possibly be due to redistribution of the porous silica nanoparticles during the holographic recording and/or to the restriction of diffusion caused by the nanoparticle structures. As the refractive index of the Si-MFI nanoparticles is lower than that of the photopolymer such an increase of refractive index modulation would be expected if the nanoparticles are excluded from the bright fringes and concentrated into the dark fringes. However, no improvement of the light induced refractive index modulation at low spatial frequency of 200 l/mm was observed. This observation implies that at such large fringe spacing of 5 μm no significant redistribution of the nanoparticles occur. Moreover, shrinkage studies show significantly lower levels of shrinkage of acrylamide-based photopolymer in the presence of silica nanoparticles. This is probably due to increased mechanical stability of the photopolymer system containing nanoparticles. Further study will quantify diffusion rates and determine the role of the nanoparticle in this improvement process.

ACKNOWLEDGMENTS

COST Action P8 "Materials and Systems for Optical Data Storage and Processing", FOCAS Institute - funded under the Programme for Research in Third Level Institutions (PRTL), Arnold F. Graves Postdoctoral Programme, DIT

REFERENCES

1. Martin, S., Leclere, P., Renotte, Y., Toal, V. and Lion, Y., "Characterisation of an acrylamide-based dry photopolymer holographic recording material" *Optical Engineering*, **33** (12), 3942-3946 (1995).
2. Blaya S, Carretero L, Mallavia R, Fimia A, Madrigal RF, Ulibarrena M, Levy D, "Optimization of an acrylamide-based dry film used for holographic recording", *Appl. Opt.*, **37** (32), 7604-7610 (1998).
3. S. Gallego, C. Neipp, M. Ortuno, A. Marquez, A. Belendez and I. Pascual, "Diffusion-based model to predict the conservation of gratings recorded in poly vinyl alcohol-acrylamide photopolymer", *Appl. Opt.*, **42**, (29), 5839 - 5845 (2003).
4. H. Sherif, I. Naydenova, S. Martin, C. McGinn, and V. Toal, "Characterisation of an acrylamide-based photopolymer for data storage utilizing holographic angular multiplexing," *J. Opt. A: Pure Appl. Opt.*, **7**, 255-260 (2005).
5. N. Suzuki, Y. Tomita, T. Kojima, "Holographic recording in TiO₂ nanoparticle-dispersed methacrylate photopolymer films", *Appl. Phys. Lett.*, **81**, 4121 (2002).
6. Y. Tomita and H. Nishibiraki, Improvement of holographic recording sensitivities in the green in SiO₂ nanoparticle-dispersed methacrylate photopolymers doped with pyromethene dyes", **83**, (3), 410-412, (2003).
7. Suzuki N, Tomita Y, "Silica-nanoparticle-dispersed methacrylate photopolymers with net diffraction efficiency near 100%", *Appl. Opt.*, **43** (10), 2125-2129 (2004).
8. Dhar L, Hale A, Katz HE, Schilling ML, Schnoes MG, Schilling FC, "Recording media that exhibit high dynamic range for digital holographic data storage", *Opt. Lett.*, **24**, 487-489 (1999).
9. Suzuki N, Chikama K, "Holographic manipulation of nanoparticle distribution morphology in nanoparticle-dispersed photopolymers", *Opt. Lett.* **30** (8), 839-841 (2005).
10. V. Kondilenko, V. Markov, S. Odulov and M. Soskin, "Diffraction of coupled waves and determination of phase mismatch between holographic and fringe pattern", *Optica Acta*, **29**, (2), 239-251 (1979).
11. H. Kogelnik, *Bell Syst. Tech. J.* **48**, 2909-2947 (1969).
12. I. Naydenova, S. Martin, R. Jallapuram, R. Howard, V. Toal, "Investigations of the diffusion processes in self-processing acrylamide-based photopolymer system," *Applied Optics*, **43** (14), 2900- 2905 (2004).
13. S. Martin, I. Naydenova, R. Jallapuram, R. Howard, V. Toal, "Two way diffusion model for the recording mechanism in a self developing dry acrylamide photopolymer", *SPIE Proceeding of HOLO'5*, 21-25 May, Varna (2005).
14. G. Zhao and P. Mourolis, "Diffusion model of hologram formation in dry photopolymer materials", *J. Mod. Opt.* **41**, 1929-1939 (1994).
15. J. H. Kwon, H. C. Hwang and K. C. Woo, "Analysis of temporal behaviour of beams diffracted by volume gratings formed in photopolymers", *J. Opt. Soc. Am. B* **16**, 1651-1657 (1999).
16. S. Piazzolla and B. Jenkins, "First harmonic diffusion model for holographic grating formation in photopolymers", *J. Opt. Soc. Am. B* **17**, 1147-1157 (2000).
17. J. Lawrence, F. O'Neill and J. Sheridan, "Adjusted intensity nonlocal diffusion model of photopolymer grating formation", *J. Opt. Soc. Am. B* **19**, 621-629 (2002).