

2012-8

An Audit in Respect of the Electrical Safety Implications for Domestic Electrical Installations

Noel Masterson [Thesis]

Technological University Dublin, noel.masterson@tudublin.ie

Follow this and additional works at: <https://arrow.tudublin.ie/schfsehoth>



Part of the [Pharmacology, Toxicology and Environmental Health Commons](#)

Recommended Citation

Masterson, N. : An Audit in Respect of the Electrical Safety Implications for Domestic Electrical Installations, Dissertation, MSc. in Environmental and Safety Management, Technological University Dublin, 2012.

This Theses, Masters is brought to you for free and open access by the School of Food Science and Environmental Health at ARROW@TU Dublin. It has been accepted for inclusion in Other resources by an authorized administrator of ARROW@TU Dublin. For more information, please contact yvonne.desmond@tudublin.ie, arrow.admin@tudublin.ie, brian.widdis@tudublin.ie.



This work is licensed under a [Creative Commons Attribution-Noncommercial-Share Alike 3.0 License](#)

An Audit in respect of the Electrical Safety Implications for Domestic Electrical Installations

By

Noel Masterson

SUBMITTED IN PARTIAL FULFILMENT OF THE REQUIREMENTS FOR THE AWARD OF
MASTER OF SCIENCE (ENVIRONMENTAL AND SAFETY MANAGEMENT)

SCHOOL OF FOOD SCIENCE AND ENVIRONMENT HEALTH
COLLEGE OF SCIENCES AND HEALTH
DUBLIN INSTITUTE OF TECHNOLOGY
Programme Code: DT442T



Supervisor: Mr. Victor Hrymak

Submitted to Dublin Institute of Technology – August 2012



DUBLIN INSTITUTE OF TECHNOLOGY
COLLEGE OF SCIENCES AND HEALTH
SCHOOL OF FOOD SCIENCE AND ENVIRONMENT HEALTH

Programme Code: DT442T
Student Number

Declaration

The substance of this thesis is the original work of the author and due reference and acknowledgement has been made, where necessary, to the work of others. No part of this thesis has already been submitted for any degree and is not being concurrently submitted in candidature for any other degree.

Noel Masterson

Candidate, D10120199
School of Food Science and Environmental Health
September 2012

Abstract

Ireland, throughout the years known as the “Celtic Tiger” experienced a level of growth which culminated in many new developments in the construction sector. The building “boom” of those years, was not solely monopolised by the Industrial sector; many owner/occupiers of domestic premises were in a position to develop or upgrade their existing dwellings. Current literature indicates that the poor condition of domestic electrical installations throughout Europe has raised concerns in respect of the safety of the owner/occupier.

This study addresses:

- The quality of Domestic electrical installations, periodic testing, inspection and verification
- The Rules and regulations as developed by relevant stakeholders within the sector and enforced by the statutory bodies
- Testing requirements in domestic electrical installations which underpin safety for the occupier.
- The occupancy and the environmental conditions of the premises as this is an important factor, dictating the frequency of periodic inspection and verification

This research complies with the National Rules for Electrical Installations ET 101:2008 4th Edition and this study will also conform to the standard norms custom and practice across the sector. There are certain steps to the verification and testing procedure: from inspection, incorporating all of the senses, to the actual tests, which address deficits not identified in the inspection process. Such regimes are implemented with fully calibrated testing equipment thereby ensuring safety and functionality in ascertaining the quality of the electrical installation. The research poses a series of questions, directed at industrial practitioners and stakeholders in the electrical services engineering sector involving the following: The owners /occupiers A cohort of electrical apprenticeship students/Registered electrical contractors

Qualitative and quantitative analysis was undertaken to ascertain the concerns and views of these important stakeholders. Statistical data collected from 15 domestic electrical installations collected and reviewed

Acknowledgements

I would like to convey my appreciation to the following for their kindness, support, helpful suggestions, and positive feedback, without which this work would not be possible.

Thank you.

Project Supervisor:	Mr. Victor Hrymak School of Food Science and Environmental Health, Dublin Institute of Technology.
Family members	To my wife; Sarah and my Children; Sean and Sorcha without their constant help and support it would not have been possible to complete this work.
DIT Staff Training and Development	This research has been approved under the fee support scheme for advanced qualifications through DIT Staff Training and Development.
Readers:	Members of staff, School of Electrical; Engineering Systems, DIT, Kevin Street, Dublin 8. Mr. Dick O'Rourke Mr. Thomas Shannon
Register of Electrical Contractors of Ireland	Mr. Paul Waldron, General Manager of RECI/RGII, for providing access to the RECI web-site which facilitated the distribution of the verification and testing survey, without which the completion of the research would be impossible.
Buildings Maintenance Supervisor	Mr. Colm Gillen, Buildings Maintenance Manager, Dublin Institute of Technology, Kevin Street, Dublin 8 I wish to acknowledge the help and support of Colm; who took the time to provide information and encouragement which was vital across the duration of the MSc. Programme.

<p>Respondents to the Questionnaire:</p>	<p>Students on their Phase 6 programme of their Standards-Based Apprenticeship and to members of the SSB's who took the time to complete the questionnaires and who provided feedback on the condition of various electrical installations in respect of the housing survey.</p>
<p>Owner/Occupiers of Surveyed Premises</p>	<p>A final word of thanks to the residents and home owners who participated and facilitated the author while conducting this research</p>

Table of Contents

1.1 Public awareness in respect of Electricity	1
1.2 Fires in electrical installations	1
1.3 Fire as a significant danger	2
1.4 Improved health and safety practices	4
1.5 Electrical Fatalities 1995 to 2012	4
2.1.0 Chapter Two – Introduction to Review of Literature	7
2.1.1 Introduction to Section No. 1	10
2.1.2 Index of Equipment and Machinery	11
2.1.3 Safety, Health and Safety at Work Act 2005 – No. 10 of 2005	12
2.1.3 Safety, Health and Welfare at Work (General Application) Regulations 2007	14
2.1.5 Residual Current Devices (RCDs) – Introduction	16
2.1.6 Residual Current Devices (RCDs) – Shock & Fire Protection	18
2.1.7 Residual Current Devices (RCD) –	19
2.1.8 Residual Current Devices (RCD) – Testing	19
2.2.0 Section.No.2	21
2.2.2 Fire Prevention in Buildings (electrical)	22
2.2.3 Physiological Effects of Fire on the Human Body	23
2.5.1 Legislation and Guidance	25
2.5.2 Dangers associated with electricity	25
2.5.3 Electro-Technical Council of Ireland (ETCI)	25
2.5.4 Inspection and Testing of Installations	26
2.5.5 Commission for Energy Regulation (CER)	27
2.5.6 Role of the Safety Supervisory Bodies (SSB's)	28
2.5.7 Regulatory Framework	30
2.5.8 The Criteria Document consists of a series of Common Procedures	30
2.5.9 Qualified Certifier's Requirements	31
2.5.10 National Rules for Electrical Installations ET101:2008	32
2.5.11 National Rules for Electrical Installations in Potentially Explosive Atmospheres ET105:2011	35
3.1 Chapter Three – Objectives of the Study	37

4.1 Chapter Four – Details of Study	39
4.2 The Objectives of the Study	39
4.3 Verification and testing Phase 4 Module	40
4.4 Verification and testing Phase 6 Module	40
4.5 Survey of Electrical Apprentices Phase 6 Students	41
4.6 Ethical considerations	43
4.7 An introduction to primary data collection	43
4.8 Assumptions with Primary Data	44
4.9 Questionnaire and Data composition	44
4.10 Survey of Registered Electrical Contractors	45
4.11 Questionnaire distribution	46
5.1 Chapter Five –Q1 Importance of retesting a domestic installation	51
5.3 Q3 What is the maximum Disconnection time for a 20A Type B MCB on socket circuit	62
5.4 Q.4 when checking a 20A C Type MCB on a domestic socket circuit what is the maximum value of fault loop impedance	66
5.5 Q5 What is the maximum Disconnecting of a 30 milli ampere RCD	69
5.6 Q 6 what are the two main post-connection tests for an installation	71
5.7 Q 7According to the ETCI why are Wiring Rules so strict for bathrooms	77
5.8 Q 8According to the ETCI why does the Wiring Rules place so much importance on the location of the Distribution Board	85
5.9 Q 9What is a TN-C System of protection	91
6.1 Chapter Six – Audit of (Domestic) Electrical Installations	97
6.2 Introduction	97
6.3 Rationale	97
6.4 Analysis	97
6.4.1 Categorisation of the domestic dwellings	98
6.4.2 Outcomes of Domestic Installation Audit	99
6.5 Conclusion	102
7.1 Chapter Seven – Discussion – Introduction	104
7.2 Existing Regulation of Electrical Contractor Safety	104
7.3 Existing Regulatory Model	105
7.4 Scale of Current System	109
7.5 Legislative Requirements Concerning the New Regulatory Model	109

7.6 Energy (Miscellaneous Provisions) Act 2006 – No. 40 of 2006	109
8.1 Chapter Eight – Conclusion and Recommendations	113
8.2 Main Findings of Dissertation	113
8.3 Summary report of Audit on domestic electrical installations	115
8.4 Further research into Verification and Testing	123
8.5 Role of CER in Verification and Testing	123
Formcentral Questionnaire Distributed online--- RECI website]	136
Appendix B	139
Summary Report on Survey of Registered Electrical Contractors	139
Results of Survey	139
Appendix C	147
Reference Address	147

List of Tables

Table 1.3.1 – Attributed Cause (Domestic Fires involving a fatality 2004-2008)	3
Table 1.3.2 – Attributed Cause (Domestic Fires involving a fatality 2004-2008)	3
Table 1.4.1 – Electrical Fatalities 1995 to 2010	5
Table 2.1.1 – 8 Parts and 89 Sections of 2005 Act	13
Table 2.1.2 – Schedules of the 2005 Act	13
Table 2.1.3 – 8 Parts and 151 Regulations S. I. 299 of 2007	14
Table 2.1.4 – 10 Schedules of S. I. 299 of 2007	15
Table 2.1.5 – Verification of operation of G-Type RCDs	20
Table 2.1.6 – Verification of operation of S-Type RCDs	20
Table 2.2.1 – Fire Preventative Measures in ET101:2008	22
Table 4.4.1 – Pre connection Tests	41
Table 4.4.2 – Post connection Tests	41
Table 4.5.1 – Survey Questions	42
Table 5.1.1 – Response to question No. 1 – Raw data	51
Table 5.1.2 – Response to question No. 1 – cleansed data	54
Table 5.2.1 – Response to question No. 2 – Raw data	56
Table 5.2.2 – Response to question No. 2 – Cleansed data	57
Table 5.2.3 – Routine Check requirement in the United Kingdom	60
Reference Key:	60
Table 5.3.1 – Response to question No. 3 – Raw data	62
Table 5.3.4 – Response to question No. 3 – Cleaned data	65
Table 5.4.1 – Responses to question No. 4 – Raw data	66
Table 5.4.2 – Responses to question No. 4 – Cleansed data	68
Table 5.4.3 – Correct solution to question No. 4 (Source: ET101:2008 page 35)	68
Table 5.6.1 – Response to question No. 6 – Raw data	71
Table 5.6.4 – Response to question No. 6 – Cleansed data	75
Table 5.7.1 – Response to question No. 7 – Raw data	77
Table 5.8.1 – Response to question No. 7 – Raw data	85
Table 5.8.2 – Response to question No. 8 – Cleansed data	90
Table 5.9.1 – Response to question No. 9 – Raw data	91
Table 5.9.2 – Response to question No. 9 – Cleansed data	94

Table 6.4.1 – Breakdown of installation demographics	98
Table 6.4.2 – Summary Results concerning installation compliance	98
Table 6.4.3 – Residential type summary	98
Table 6.4.4 – Range of contraction year across sample of domestic electrical installations	99
Table 6.4.5 – Quality observed within the installation sample set	99
Table 6.4.6 – Cross-referencing bonding standards against the age of the installation	100
Table 6.4.7 – Cross-referencing main earthing requirements against the age of the installation	100
Table 6.4.8 – Distribution board audit & associated (sample) compliance	101
REFERENCES	124

List of Figures

Figure 2.1.1 – Three phase RCD	17
Figure 2.1.2 – Physical Appearance of a Single Phase and a Three Phase RCD	17
Figure 2.5.2 – Safe Electric Logo	28
Figure 2.5.4 – National Rules for Electrical Installations in Potentially Explosive Atmospheres – ET105:2011	35
Figure 4.10.1 – Safety Supervisory bodies	45
Figure 4.10.2 – Register of Electrical Contractors of Ireland	46
Figure 4.11.1 – Adobe Life Cycle Data Sheet	47
Figure 4.11.2 – Adobe Fromcentral grid	48
Figure 5.1.1 – Response to question No. 1 – Raw data	51
Figure 5.1.2 – Response to question No. 1 – Cleansed data	55
Figure 5.2.1 – Response to question No. 2 – Raw data	56
Figure 5.2.2 – Response to question No. 2 – Cleansed data	57
Figure 5.3.1 – Response to question No. 3 – Raw data	62
Figure 5.3.2 – Response to question No. 3 – Cleaned data	65
Figure 5.4.1 – Responses to question No. 4 – Raw data	66
Figure 5.4.2 – Responses to question No. 4 – Cleansed data	68
Figure 5.5.1 – Responses to question No. 5 – Raw data	70
Figure 5.6.1 – Response to question No. 6 – Raw data	71
Figure 5.6.2 – Response to question No. 6 – Cleaned data	76
Figure 5.7.2 – Response to question No. 7 – Raw data	77
Figure 5.7.3 – Example of Zone Dimensions –Plan view (Source ET101 :2008 – page 171)	80
Figure 5.7.4 – Examples of Zone Dimensions – Elevation view	81
Figure 5.7.5 – Prefabricated Shower Unit (Source ET101:2008 – page 173)	81
Figure 5.7.6 – Response to question No. 7 – Cleansed data	83
Figure 5.8.1 – Response to question No. 8 – Raw data	85
Figure 5.8.2 – Diagram of a fuse board in a domestic dwelling	87
Figure 5.8.3 – Diagram of a distribution board in a domestic dwelling	87
Figure 5.9.1 – Response to question No. 9 – Raw data	91
Figure 5.9.2 – TN-C system of earthing	92
Figure 5.9.3 – TN-C-S system of earthing	93
Summary of results	95
Figure 6.34.1 – Parameterisation within SPSS (screen shot)	102
Figure 8.3.1 – Pre 1960’s fuse board with coin metre	116
Figure 8.3.3 – Pre 1980’s fuse board with service cut-out and metre	117
Figure 8.3.4 – Post 1980’s distribution board (consumer unit)	118
Figure 8.3.6 – Post 1980’s distribution board (consumer unit); Unacceptable	118
Figure 8.3.7 – 1990’s distribution board (consumer unit) with warning label attached	119
Figure 8.3.8 – Circuit functionality and protective devices	120
Figure 8.3.9 – Circuit functionality and extract fan	120
Figure 8.3.10 – Circuit functionality compromised by over load	121
Figure 8.4.11 – Earth clamp connection	122
Figure 8.4.12 – Earth clamp connection with anti-vibration device	122

Glossary of Terms

ACCESSIBILITY of ELECTRICAL EQUIPMENT: (1) Electrical equipment should be arranged so as to afford, sufficient space for the initial installation and later replacement of individual items of electrical equipment (2) accessibility for operating, testing, inspection, maintenance and repair

AIE: European Association of Electrical Contractors

AEC: Association of Electrical Contractors

AUTHORISED PERSON: A person who is competent for the particular purposes of these Rules in relation to which the expression is used and who is also either the occupier, or a contractor who is for the time being under contract with the occupier or such contractor, to carry out work or duties incidental to the generation, transformation,

ATEX: Atmospheres Exposable (i.e. Explosive Atmospheres).

BASIC INSULATION: Insulation applied to live parts to provide basic protection against shock

BREAKING CAPACITY: A value of current that a protective device is capable of breaking at a specified voltage and under prescribed conditions of use and voltage

CABLE: An insulated conductor with an outer protective covering against external influences

CER: Commission for Energy Regulation.

CENELEC: European Committee for Electrotechnical Standardisation.

CIRCUIT: Part of an electrical installation supplied from the same origin and protected against overcurrent by a single protective device

CIRCUIT BREAKER: A mechanical device capable of making, breaking and carrying current under normal circuit conditions and also capable of making and carrying for a specified time and breaking currents under specified abnormal circuit conditions such as those of short circuit

CURRENT CARRYING CAPACITY (of a conductor): The maximum current that can be carried continuously by a conductor under specified conditions of external influences

DISTRIBUTION BOARD: An assembly of protective devices, including two or more fuses or circuit breakers, arranged for the distribution of electrical energy to final circuits or other distribution boards.

DESIGN CURRENT (of a circuit): A current intended to be carried by a circuit in normal service

ECBL: The European Confederation of National Associations of Manufacturers of Insulated Wire and Cable Euroclass

ECI: European Copper Institute

ET 101:2008: National Rules and Regulations for Electrical Installations. (4thEdition).

EARTHING: The connection of the exposed conductive parts of the installation to the main earthing terminal or bar

EARTHING CONDUCTOR: A conductor connecting the main earthing terminal or bar to the earth electrode

EARTHING RESISTANCE: The resistance between the main earthing terminal and earth

EARTH -FAULT CURRENT: A fault current that flows to earth, either directly or through a protective conductor

ECSSAI: Electrical Contractors Safety & Standards Association (Ireland).

ELECTRICAL INSTALLATION: An assembly of associated electrical equipment to fulfil a specific purpose or purposes and having co-ordinated characteristics

ETCI: Electro-Technical Council of Ireland Limited (ETCI).

EUEW: European Union of Electrical Wholesalers

EQUIPOTENTIAL BONDING: Electrical connections intended to maintain exposed conductive parts and extraneous conductive parts at the same or approximately the same potential, but not at intended to carry current in normal service

EQUIPOTENTIAL BONDING CONDUCTOR: A protective conductor for ensuring equipotential bonding

EXPOSED CONDUCTOR PART: A conductive part of electrical equipment, which can be touched and is not normally live, but may become live under fault conditions

EXTRANEOUS CONDUCTIVE PART: A conductive part, not forming part of the electrical installation liable to introduce a potential, generally the earth potential (i.e. Metalwork of a structure gas, heating or water pipes. non-electrical apparatus such as metal sinks, gas or coal fired ranges)

EXTERNAL INFLUENCE: Any influence external to an installation which effects the design or safety of the installation

FAULT: Contact of a live part with exposed or extraneous conductive part which is caused by accident or failure of insulation

FAULT CURRENT: A current resulting from an insulation failure or bridging of insulation

FAULT LOOP IMPEDANCE: The impedance of the fault current loop (phase to earth loop) starting and ending at the point.

FEEDS: Forum for European Electrical Domestic Safety

FELV; Extra low voltage that does not satisfy the safety requirements of SELV or PELV

HSA: Health and Safety Authority.

HAZARDOUS LIVE PART: A live part which under certain conditions give electric shock

INITIAL VERIFICATION: Electrical installations including modifications and extensions shall be tested and inspected before being placed in order to verify compliance with the National Rules for Electrical Installations

INSPECTION: Examination of an electrical installation using all the senses in order to ascertain the correct selection and proper erection of electrical equipment

LEAKAGE CURRENT (in an installation): A current that flows to earth or to extraneous conductive parts in an electrically undamaged circuit

LOW VOLTAGE: .A nominal voltage exceeding 50V.ac or 120 V.dc but not exceeding 1000 V.ac or 1500 V.dc

MCB: Miniature Circuit Breaker.

MAIN EARTHING TERMINAL or BAR: A terminal or bar provided for the connection of protective conductors, main equipotential bonding conductors for functional earthing if any, to the means of earthing

NOMINAL VOLTAGE: A voltage by which an installation or part of an installation, is designated

NEUTRAL CONDUCTOR (symbol N) : A conductor connected to the neutral point of a system for the purpose of transmitting electrical energy

PERIODIC INSPECTION and TESTING: It is recommended that every electrical installation be impedance inspected and tested periodically as appropriate to the use and external influences to ensure it complies with the National Rules for Electrical Installations

PELV: Any voltage not exceeding 50V.a.c or 120Vd.c between conductors at any point of the circuit which is separated from circuits with higher voltages by insulation at least equivalent to that for Class I or which has equivalent protective means and where one point in the circuit is connected to earth for functional purposes

POINT (in wiring): A termination of the fixed wiring intended for the connection of current using equipment

PROSPECTIVE SHORT CIRCUIT CURRENT: The value of short circuit current that would flow if the current-limiting device were replaced with a conductor of negligible impedance

PROTECTIVE CONDUCTOR (symbol PE): A conductor required for certain measures of protection against electric shock which- electrically connects any of the following parts

- (a) Exposed conductive parts
- (b) Extraneous conductive parts
- (c) Main earthing terminal
- (d) earthed point of the source or artificial neutral

REC: Registered Electrical Contractor.

RECI: Register of Electrical Contractors of Ireland.

RCD: A mechanical switching device intended to disconnect a circuit when the residual current attains a stated value under specific conditions

RCCB: Residual current –operated circuit breaker, a mechanical switching device designed to make, carry and break currents under normal service conditions and to cause the opening of the contacts when the residual current reaches attains a stated value under specified conditions

RCBO: Residual current –operated circuit breaker designed to perform the functions of protection against overloads and /or short circuits.

SELV: A voltage not exceeding 50V.a.c or 120Vd.c between conductors at any point of the circuit which is separated from circuits with higher voltages by insulation at least equivalent to that for Class I or which has equivalent protective means.

SERVICE SHORT-CIRCUIT BREAKING CAPACITY (of a circuit breaker): A breaking capacity for which the prescribed conditions according to the specified test sequence include the capability of the circuit-breaker to carry its rated current continuously

SHORT CIRCUIT CURRENT: An overcurrent resulting from the fault of negligible impedance between live conductors having a difference of potential under normal operating conditions

S.I.: Statutory Instrument.

SSB: Safety Supervisory Body.

Chapter One

Introduction

1.1 Public awareness in respect of Electricity

The awareness of the public in regard to electrical safety seems to suggest that a greater understanding may be needed and further input from the institutional bodies in charge of electrical regulations be intensified.

Since the 5th January 2009 the Commission for Energy Regulation (CER) is responsible for the regulation of Registered Electrical Contractors with respect to safety. Only a “*Qualified Certifier*” is entitled to issue completion certificates and sub-system certificates for *Controlled Works*. According to the regulations a *Qualified Certifier* must have completed a recognised training course on Verification and Certification of Electrical Installations within the previous three years.

The requirements, with respect to verification and testing of electrical installations are set out in the Safety, Health and Welfare at Work General Application), Regulations (2007) S.I. 299 part 3. Verification and Certification of Electrical Installations must be in accordance with the National Rules for Electrical Installations ET 101: 2008 – 4th Edition and any amendments to the rules. The Commission for Energy Regulation (CER) will regulate enforcement through the safety supervisory bodies. This means that a significant number of electricians working in the industry are now required to attend a recognised Verification and Certification course periodically (as prescribed by CER) to fulfil the requirements of the regulatory system.

1.2 Fires in electrical installations

The greatest danger of under-maintained electrical installations is fire. An investigation of the Merseyside Fire and Rescue Service (UK) from 17 April 2008 to 8 December 2008 showed that 79% of the accidental primary fires were caused by faults in the electrical installation(Leonardo Energy, January.2010)

When considering purchasing a house or apartment or any dwelling for residence, one of the major issues should be that it is electrically safe to live in. To this end personal safety and

that of other residents should be assured in the knowledge that all appliances, electrical systems and components are functioning correctly. This safety aspect if checked on a regular basis also combines to save the purchaser in energy costs during the lifetime of the system.

When reviewing the safety of a domestic installation there are quality requirements which must be attained, the main starting point would be the previous and current condition of the installation if it was rewired or renovated. The point being, safety at all times must be to the forefront of the occupants thoughts. One good reason for prioritising electrical safety in the home is the increasing use and abundance of modern electrical appliances. Overloading of circuits in a house is now a serious concern for most households due to the fact that when the house was designed the electrical outlet condition was never perceived to have the growth that it has achieved.

1.3 Fire as a significant danger

This view is echoed by (Barrett. M and O'Connell. K, 2010) who quote a UK study by (Samuelson-Brown and Thornton, 1997) of home renovation highlighted the fact that even when some dwellings are renovated the required level of safety is not necessarily achieved, the study findings revealed that just around 20% invested in a new consumer unit while 15% got the dwelling completed rewired .It would seem that the public consider that just adding on to existing installations does not affect the installation in any great way. Constant reminders of the dangers and the need to maintain a safe environment can only help to reduce the levels of accidents and deaths. The risk of electrical shocks and faulty electrical appliances possibly causing fire would be the significant dangers in any domestic installation

On the 10th November 2009 the then Minister of State with special responsibility for Housing and Local Services, Mr Michael Finneran (Finneran et al., 10 Nov 2009) provided the Dáil with a “written answer” query, with statistics supplied to is department by fire authorities to indicate that there were 157 domestic fatal fires which resulted in 179 fatalities in the period 2004 - 2008. The attributed cause of these fatalities, as reported by the fire authorities and the presence or otherwise of smoke alarms at these incidents, are indicated in Table 1.3.1 and Table 1.3.2 below. Over half the fatal fire incidents occurred where there was no smoke alarm or no working smoke alarm on the premises. Electrical appliances and wiring faults which are included as causes of fire amount to 15% or 23 fatalities

Attributed Cause	Case Number.	Percentage
Unknown Cause	54	34%
Cigarette / Smoking materials	31	20%
Under Investigation by An Garda Siochana	25	16%
Electrical Appliance	19	12%
Candle	6	4%
Chip Pan	4	3%
Electrical Wiring	4	3%
Open Fire	3	2%
Chimney Fire	3	2%
Solid Fuel Appliance	3	2%
Other causes	3	2%
	TOTAL 157	15%

Table 1.3.1 – Attributed Cause (Domestic Fires involving a fatality 2004-2008)

No Smoke Alarm	78	50%
Not Known	32	20%
Smoke alarm installed and working	25	16%
Smoke alarm installed and not working	13	8%
Smoke alarm installed working status unknown	9	6%

Table 1.3.2 – Attributed Cause (Domestic Fires involving a fatality 2004-2008)

(An aside: A simple battery driven smoke alarm may have helped reduce the high fatality rate over these years. These high rates instigated a campaign during the all island “National Fire Safety Week” to encourage the necessity of smoke alarms in domestic dwellings.)

1.4 Improved health and safety practices

Health Safety and Welfare practices have changed in no large way across all areas of society emanating from early Barrington reports, (Barrington, J. (1983) which is now embedded into every Safety, Health and Welfare at Work Act.

But the evidence shows fatalities from suspected electrical faults are high when you consider that electrical and fire safety plays a major part in the policies of successive governments, fire authority, electrical bodies and health and safety organisations in Ireland.

Mandatory re-testing and verification of electrical installations may have significant role in reducing fatalities

The quality of domestic electrical installations and the appliances which are installed and used in most dwellings should be subject to regular investigation, simply because, the dangers of electricity and the severe damage it can cause cannot be underestimated or ignored. Poor quality installations, non-maintained components, faulty appliances and general lack of understanding of electricity contribute to accidents and deaths in the workplace and at home.

1.5 Electrical Fatalities 1995 to 2012

Data provided the Electro-Technical Council of Ireland (ETCI) has indicated that electrical fatalities in Ireland since 1995 -2010 shows, there have been 60 incidents from the explosive/burning effects of electricity since 1995 up to 2010.

Statistics related to work activity indicated 39 fatalities with 21 fatalities relating to domestic situations. Fatalities can be attributed to trespassing, vandalism and a single report relating to fallen overhead power lines.

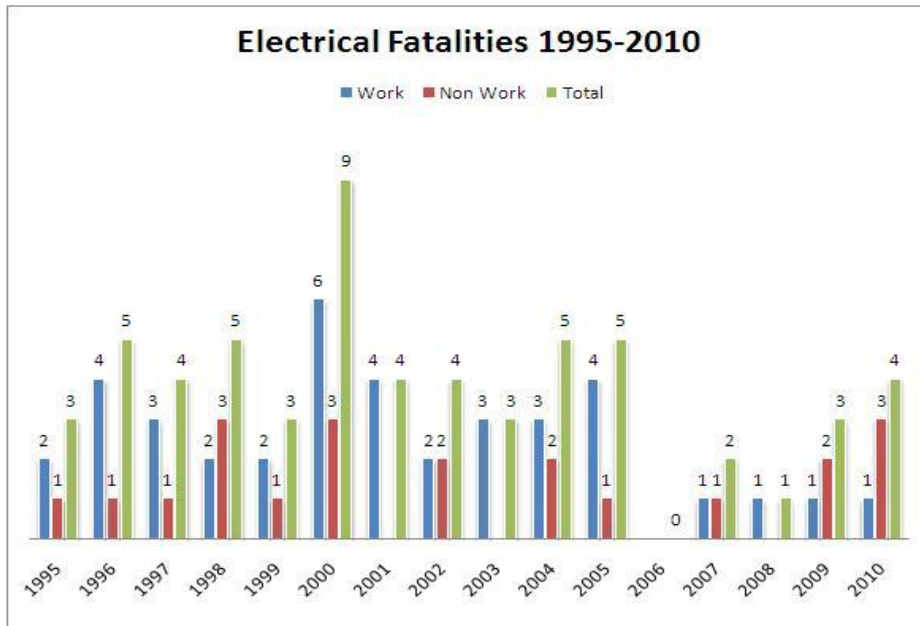

Table 1.4.1 – Electrical Fatalities 1995 to 2010

The statistics indicate in industry or domestic settings people can encounter inferior electrical installations systems or numerous faulty appliances, leading to fatality or injury. The statistics above show both work related and non –work fatalities but even minor electrical accidents can have major repercussions such as shocks or burns causing damage and injury ranging from mild, severe to permanent disability.

This study will focus on a sample of domestic electrical installations and will discuss broadly the rules, regulations and codes of practice pertaining to testing and verification of a sample of electrical installations in Ireland

Chapter 2 will show a wide variety of legislation and literature and regulations which covers many of the constituents that form domestic and elements of industrial electrical supply conditions.

Chapter Two

Review of Literature

2.1.0 Chapter Two – Introduction to Review of Literature

The review of literature in respect of Electrical Safety undertaken examined the current situation in respect of the utilisation of electrical energy,; the literature available is extensive it can be reviewed in five sections.

For the purpose of this methodology, **Sections 1, Section 2** and **Section 5** will be the main areas of interest giving focus to the practical aspects of electrical safety.

Section 1 – Safety, Health and Legislative requirements in relation to Electricity and Construction;

- An outline of the Safety Health and Welfare at Work Act 2005 – No 10 2005
- Safety, Health and Welfare at Work (General Application) Regulations 2007 S. I. 299 2007
- (Part III regulations 74 to 93)
- Safety, Health and Welfare at Work (Construction) Regulations 2006 S. I. 504 2006
- Compliance with the relevant Code of Practice (COP) in relation to electricity
- Knowledge of the operation and application of the RCD
- ETCI requirements in respect of the RCD and comprehend compliance with testing of the RCD – Annex 61G of the ETCI rules.

Section 2 – Introduction to the Prevention of Fire-Spread in Buildings;

- Fire Services Act 1981
- “Code of Practice for the Management of Fire Safety in Places of Assembly (1991)” published by the Department of the Environment.
- Disability Act 2005 No 14 of 2005 – Part III
- Part M of the Building Regulations 1997 (S.I. No. 497 of 1997)
- Psychological effects of combustion gasses
- Use of First Aid Fire Safety Equipment, Extinguishers, Hose Reels etc.

- The introduction of regular inspections and the identification and elimination of fire hazards.
- The operation of an appropriate programme of emergency fire training for all staff.
- The display of floor plans in prominent locations, which clearly indicate escape routes from all locations in the buildings.
- The establishment of an effective evacuation procedure to assembly areas outside the buildings.
- The provision and maintenance of fire-fighting equipment.
- Evacuation procedures for inambulant persons
- Access and Egress for inambulant persons
- Personal Emergence Egress Plans for inambulant persons

Section 3 – SHWW (Construction) Regulations S. I. 504 of 2006

- Design and Management regulations 6 to regulation 23 (inclusive)
- Safety File Regulation 13 (page 39) and Regulation 21 (page 52)
- Contents of the Safety File
- What information should be included in the safety file?
- What happens the safety file when the project is completed?
- During the construction stage what emergency plans are required for the site?
- Outline the requirements in respect of COPS in relation to electricity.
- Outline the contents of the safety statement relating to the construction stage of the project.
- Contractors and Sub-contractors insurance requirements in respect of protection of site workers.
- Atex Regulations
- List of forms required for the SHWW (Construction) Regulations 2006 – SI 504 of 2006

Section 4 – Introduction to Risk Management and Safety Technology

- Introduction to risk management and safety technology
- Identify and classify hazards.
- Apply hazard assessment and evaluation tables and calculate hazard rating numbers
- Evaluate incidents in terms of risk level and action time required to eliminate risk
- Carry out risk assessments.
- Interpret and analyse information relevant to safety at work.

Section 5 – The roles of the Health and Safety Authority (I), the Electro-Technical Council of Ireland (ETCI), the Commission for Energy Regulation (CER) and the Safety Supervisory Bodies (SSB) in respect of electrical safety and in particular the process of Verification and Testing of Electrical Installations.

- Legislation and Guidance in respect of Electricity
- Dangers associated with electricity
- Electrical Fatalities – 1995 to 2011
- Inspection and Testing of electrical installations
- CER’s Criteria Documents
- The role of the Commission for Energy Regulation
- The National Rules for Electrical Installations – ET101:2008
- The National Rules for Electrical Installations in Potentially Explosive Atmospheres – ET105:2011
- Electrical Installation work needing Certification

2.1.1 Introduction to Section No. 1

The Safety, Health and Welfare Act 2005, together with the various updates and amendments to the Act has established a comprehensive system of law relating to all matters of safety, health and welfare at work. Statutory requirement in respect of Electrical Services Engineering can be obtained from the following sources:

- Acts of the Óireachtas
- Safety, Health and Welfare at Work Act 2005 – No. 10 of 2005
- Regulations made under Safety, Health and Welfare at Work Act 2005
- European Union Legislation
- Miscellaneous Regulations and Orders
- Approved Codes of Practice
- Codes of Practice

Statutory Inspections

Checks, inspections or tests specified in a Statutory Instrument i.e. Act and/or Regulation that is a legal requirement.

(2) Code of Practice

Codes of practice typically give practical guidance on their subject matter. They are not legally binding and as such do not have to be followed exactly. However, where the code of practice gives practical guidance on relevant statutory provisions then compliance or non-compliance with those provisions of the code may be admissible in evidence in any criminal or civil proceedings.

A person may also be able to comply with the law by adopting alternative measures to those set out in a Code of Practice, provided that those alternative measures achieve the objective of the statute or Regulation to which the Code of Practice relates. However, in a safety and health prosecution or a civil liability claim the onus of proof would rest with the defendant to show that he/she was not negligent and /or in breach of a statutory duty and that all reasonable measures were adopted to prevent against injury.

(3) Irish Standard (IS)

Refers to Irish Standards published by NSAI, which operates under the National Standards Authority of Ireland Act, 1996, on behalf of the Minister for Enterprise, Trade and Employment. These standards are standard specifications for their topic area and conformance with the standard as certified by NSAI provides proof of compliance with requirements of national standard specifications approved by The Minister for Enterprise, Trade and Employment.

(4) Irish Standard EN (IS EN)

European Norms (EN) standards aim to establish a European wide standard in a given subject area. European Standards are typically produced by European technical committees and must be given the status of a national standard, either by publication of an identical text or by endorsement and conflicting national standards must typically be withdrawn. These standards when transposed into an Irish context are denoted as IS EN.

(5) British Standard (BS)

Standards produced by the British Standards Institute. These are referenced in this text only where an applicable Irish Code of Practice or Standard (either IS or IS EN) does not exist IS; IS EN or Irish Codes of Practice should always take precedence over BS.

2.1.2 Index of Equipment and Machinery

Section 1 – Inspections covered in Statute

Passenger/Goods Lift

Work Equipment

X-Ray Units

Dental X-Ray Equipment

*Fire Detection and Alarm Systems

*Break Glass Units

Section 2 – Inspections Required by Codes of Practice

Electric Power Generators

*Residual Current Devices (RCDs)

*Earth Loop Impedance System

Section 3 – Inspections covered in Standards

*Emergency Lighting

*Please note that the sections out-lined in blue are in respect of electrical engineering systems

2.1.3 Safety, Health and Safety at Work Act 2005 – No. 10 of 2005

The Safety, Health and Welfare at Work Act 2005 (No. 10 of 2005) (hereafter called the 2005 Act) applies to employers, employees in all employments and to the self-employed. In the interests of securing a preventive approach to occupational health and safety, it also has implications for persons who control places of work and those who supply articles or substances for use at work.

The 2005 Act contains provisions for securing and improving the safety, health and welfare for all workers. It updates, repeals and replaces its predecessor, the Safety, Health and Welfare at Work Act 1989. Relevant provisions of the Safety, Health and Welfare at Work (General Application) Regulations 2001 (S.I. No. 299 of 2001) which transposed, in part, requirements of Council Directive 89/391/EEC of 12 June 1989 on the introduction of measures to encourage improvements in the health and safety of workers in the workplace and of Council Directive 91/383/EEC of the 25 June 1991 or measures to improve the safety and health at work of workers with a fixed-duration or temporary employment relationship are now included in the Safety, Health and Welfare at Work Act 2005 Act as primary legislation. The central thrust of the 2005 Act is encapsulated in the 9 General Principles of Prevention, which are set out in Schedule 3 to the Act, as follows:

1. The avoidance of risks.
2. The evaluation of unavoidable risks.
3. The combating of risks at source.
4. The adaptation of work to the individual, especially with regard to the design of places of work, the choice of work equipment and the choice of systems of work, with a view, in particular, to alleviating monotonous work and work at a predetermined work rate and to reducing the effect of this work on health.
5. The adaptation of the place of work to technical progress.

6. The replacement of dangerous articles, substances or systems of work by safe or less dangerous articles, substances or systems of work.
7. The giving of priority to collective protective measures over individual protective measures.
8. The development of an adequate prevention policy in relation to safety, health and welfare at work, which includes technology, organisation of work, working conditions, social factors and the influence of factors related to the working environment.
9. The giving of appropriate training and instructions to employees.

The Act is organised into 8 Parts and 89 Sections and 1 Schedules as follows:

Part:	Description:	Sections:
1	Preliminary and General	01 to 01 inclusive (01)
2	General Duties	08 to 11 inclusive (10)
3	Protective and Preventive Measures	18 to 24 inclusive (01)
4	Safety Representatives and Safety Consultation	25 to 31 inclusive (01)
5	The Authority	32 to 56 inclusive (25)
6	Regulations, Codes of Practice and Enforcement	51 to 16 inclusive (20)
7	Offences and Penalties	11 to 85 inclusive (09)
8	Miscellaneous	86 to 89 inclusive (04)

Table 2.1.1 – 8 Parts and 89 Sections of 2005 Act

1 Schedules as follows:

Schedule:	Description:
1	Associated Statutory Provisions
2	Existing Enactments
3	General Principles of Prevention
4	Safety Committees
5	The Authority
6	The Chief Executive
7	Regulations

Table 2.1.2 – Schedules of the 2005 Act

2.1.3 Safety, Health and Welfare at Work (General Application) Regulations 2007

The Safety, Health and Welfare at Work (General Application) Regulations 2007

(S. I. 299 of 2007) sets out how to apply the main provisions of Safety, Health, and Welfare Act 2005 from an electrical perspective there are two particular parts of the regulations that merit mention; Part 3 which deals with electricity and Part 8 which cater for Explosive Atmospheres at Work.

The health and safety authority has produced guides which ensure that the provisions of part 3 and part 8 are completely understood and these should be consulted in conjunction with the regulations themselves, part 3 consists of extracts from the National Rules for Electrical Installations ET101:2008 – 4th Edition. It must be emphasised that the regulations have legal status and must be complied with, unlike the National Rules for Electrical Installations ET101:2008 – 4th Edition which are a voluntary code.

The SHWW (General Application), Regulations 2007 are organised into 8 Parts and 115 Regulations and 10 Schedules as follows:

<i>Part:</i>	<i>Description:</i>	<i>Regulations:</i>
1	Interpretation and General	01 to 03 inclusive (03)
2	Personal Protective Equipment	04 to 11 inclusive (13)
3	Electricity	14 to 93 inclusive (20)
4	Work at Height	94 to 119 inclusive (26)
5	Physical Agents	120 to 142 inclusive (23)
6	Sensitive Risk Groups	143 to 151 inclusive (15)
7	Safety Signs and First Aid	158 to 166 inclusive (09)
8	Explosive Atmospheres at Places of Work	161 to 115 inclusive (09)

Table 2.1.3 – 8 Parts and 151 Regulations S. I. 299 of 2007

10 Schedules as follows:

Schedules	Description:	
1	Requirements for Work Equipment	
2	Personal Protective Equipment	
3	Risk Factors for Manual Handling of Loads	
4	Minimum Requirements for all Display Screen Equipment Particulars to be included in a Report of Inspection	
5	Hand-arm Vibration and Whole-body Vibration	
6	Protection of Children and Young Persons	
7	List of Agents, Processes and Working Conditions relating to	
8	Pregnant, Post Natal and Breastfeeding Employees	
9	Safety and Health Signs at Work	
10	Explosive Atmospheres	

Table 2.1.4 – 10 Schedules of S. I. 299 of 2007

Explosion prevention Document

- As a result of the European Union directive 1999/92/EC there will be by 2003 (2006 for existing workplaces) a legal duty to prepare and maintain an Explosion Protection Document with risk assessment and hazardous area classification.
- There will also be a duty to verify the overall safety of workplaces containing potentially explosive atmospheres before they are put into operation
- A competent person must carry out this verification.
- Permit to work systems will be required for all work in Hazardous Areas and suitable signs will be required at all entry points to the areas.
- Details of the Explosion Protection Document is available in the National Rules for Electrical Installations in Potentially Explosive Atmospheres ET105:2010 – 3rd Edition

2.1.5 Residual Current Devices (RCDs) – Introduction

There are two main reasons for RCD use;

- i. To comply with the ETCI rules for electrical installations.
- ii. To provide additional and a higher level of protection than that given by direct earthing, against electric shock and also against fire risk caused by earth leakage currents. Where fuses and miniature circuit breakers (MCB's) are the only means of earth fault protection, it is possible for earth fault currents to flow undetected and cause fire risk (or touch voltage problems). The use of an RCD will prevent the flow of a sustained leakage current above the sensitivity of the RCD thus greatly reducing shock and fire risk. RCD's should disconnect all live conductors in the protected circuits in the event of earth leakage current flowing.

Terms associated with RCD

The term RCD covers a variety of Residual Current Devices;

- RCCB: Residual Current Circuit Breaker used in distribution boards to protect individual or groups of circuits
- RCBO: Residual Circuit Breaker with overcurrent protection. This is a combined MCB/RCD and provides overload, short circuit and earth fault protection in one unit
- SRCD: Socket outlet with combined RCD
- PRCD: This is a portable RCD unit with an inbuilt plug top and socket outlets

Sensitivity:

This is commonly called the operation or tripping current of the device and it is the value of leakage current at which the RCD will operate. The choice of sensitivity depends on the application and must be chosen in compliance with the ETCI Rules (section 531 page 100 ET101:2008 – 4th Edition)

Sensitivity levels ($I_{\Delta n}$) in compliance with IEC 1008 are: 10, 30, 100, 300, and 500mA.

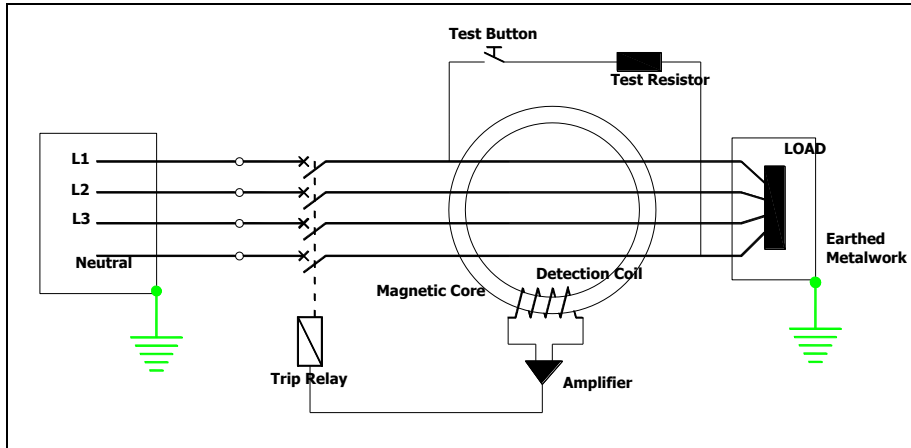

Figure 2.1.1 – Three phase RCD

Figure 2.1.1 illustrates a four pole (three-phase) RCD. This unit has four coils wound in such a way that under healthy circuit conditions there is no resultant magnetic field. A differential between any of the phase conductors will produce a magnetic field and current in the search/detection coil and cause the device to trip.

Figures 2.1.2 illustrate the physical appearance of a single phase and three-phase Residual Current Devices (RCD's).



Figure 2.1.2 – Physical Appearance of a Single Phase and a Three Phase RCD

2.1.6 Residual Current Devices (RCDs) – Shock & Fire Protection

The RCD is intended to provide protection against electric shock, which can result from a person touching an exposed live conductor (Direct Contact) or touching exposed metalwork which has a dangerous touch voltage (Indirect Contact). According to IEC 60419, two key levels of electric current need to be considered with regard to shock protection.

Level 1 Is the “let-go” level, which is generally accepted to be around 1mA. At or above this level, muscles may seize, and a person touching or holding a live part may not be able to let go of the live part. RCDs rated up to 10mA are intended for protection against “let-go” currents, and are recommended for use in hospitals and old peoples’ homes, moist or damp environments, or similar locations.

Level 2 Is the “fibrillation” level, which is generally accepted to be around 50mA. Higher than this level, heart fibrillation is likely to occur in an RCD rated up to 30mA are the upper limit for RCD intended to provide protection against fibrillation. It follows that RCDs rated >30mA are not suitable for personal protection. An RCD could provide protection against fires derived from earth fault currents, but cannot be guaranteed to prevent such fires in all cases. For example, AC Type RCD will not provide protection against pulsating DC currents flowing to earth even though such currents could result in an electrical fire.

Where an RCD is fitted to reduce the risk of fire arising from an electrical fault, the following factors should be taken into account;

IEC has specified an upper limit of 300mA for an RCD intended for fire protection.

- This is based on a power level of about 60 watts which is considered to be sufficient to cause an electric fire. This level would be exceeded at 230V for a 300mA residual current. Any RCD with a rated residual operating current not exceeding 300mA will meet this requirement.

ET101:2008 requires that any RCD used in areas of fire hazard

- Shall be limited to a maximum rated residual operating current of 300mA and that they shall disconnect all live poles of the protected circuits. (See National Rules for Electrical Installations, Third Edition, ET101, sub-clause 532.1).

Type AC RCD will only provide protection against full wave AC fault currents

- But fires can be caused by pulsating DC fault currents, and such fault currents can only be detected by Type A or Type B RCDs.

2.1.7 Residual Current Devices (RCD) –

The following RCD characteristics need to be taken into account when selecting an RCD for a particular application:

- Rated voltage & frequency
- Rated load current (I_n)
- Rated residual operating current ($I_{\Delta n}$)
- Rated making & breaking capacity (I_m)
- General or S Type
- Residual current protection, Type AC, Type A or Type B
- Number of poles to be broken
- Type of Poles, solid neutral, switched neutral or fully rated pole
- Response to loss of supply and restoration of supply

2.1.8 Residual Current Devices (RCD) – Testing

All electrical installations must be tested in accordance with the National Rules for Electrical Installations ET101:2008 – 4th Edition, Annex 61G on page 318 provides details of specific tests for the RCD. These tests should be carried out by introducing a residual current at the end of every sub-circuit downstream of the RCD. They are fitted with a test button to verify their operation. Testing of the RCD by operation of the test button should be carried out on a regular basis, e.g. every three months. However, arrangements should also be made for regular testing by application of an external residual current.

Operation of the test button results in the flow of a residual current within the RCD, causing it to trip. However, tripping of the RCD in response to operation of the test button does not verify that the RCD will provide protection as specified. For example, protection will not be assured in the case of a neutral to earth fault. Verification of the ability of the RCD to provide protection can only be assured by external testing as set out above.

By definition, AC current comprises of positive and negative half cycles with respect to a zero reference point, and an AC fault current can start to flow to earth at any point during either half cycle. An AC Type RCD will only trip in response to either the positive or

negative half cycles of the AC earth fault current, whereas an A Type RCD will respond to both half cycles. As the AC Type RCD is blind to either the positive or negative half cycles of an AC fault current, the fault current could flow for up to 10mS before the RCD will see the fault current. This 10mS will be added to the response time of the device.

RCD testers are usually provided with a switch to enable the user to start the flow of the test current at 0 degrees or 180 degrees, i.e. starting on a positive going or a negative going half cycle respectively. By starting the testing of the RCD at both settings of the test current conduction angle, the user will be able to determine the maximum trip time of the RCD.

This can be done at different test current levels.

Testing of 'G' Type & 'S' Type RCD

The operating characteristics of RCD should be ensured by injecting a test residual current through the device and recording the time of operation by using an appropriate instrument which is designed for this use. All values which are recorded should be in compliance with the tables below (National Rules for Electrical Installations ET101:2008 – 4th Edition – Amendment No. 1 ET101:2008/A1:2011

Standard Value of Operating Time for RCD – General Type

Test Current	$0.5 \times I_{\Delta n}$	$1 \times I_{\Delta n}$	$5 \times I_{\Delta n}^*$
Maximum Operating Times:	Must not operate	0.3s	0.04s

Table 2.1.5 – Verification of operation of G-Type RCDs

Standard Value of Operating Time for RCDs – Special Type S

Test Current	$0.5 \times I_{\Delta n}$	$1 \times I_{\Delta n}$	$5 \times I_{\Delta n}^*$
Maximum Operating Times:	Must not operate	0.5s	0.15s
Maximum non actuating Times:	Must not operate	0.13s	0.05s

Table 2.1.6 – Verification of operation of S-Type RCDs

$I_{\Delta n}$ is the rated residual operating current e.g. (30mA or 300mA).

For RCDs rated 30mA or less, 0.25A may be used instead of $5 I_{\Delta n}$

2.2.0 Section.No.2

2.2.1 Introduction to Section No. 2

The Fire Service Act of 1981, together with the various updates and amendments to the Act has established a comprehensive system of law relating to all matters of fire safety in respect of Electrical Services Engineering in buildings, statutory requirements can be obtained from the following sources:

- Fire Services Act 1981 – No 30 of 1981 –
- Management of Fires in Places of Assembly – Code of Practice
- Disability Act 2005 No. 14 of 2005
- Guide to the Disability Act 2005
- Technical Guidance Document M 2000
- Safety, Health and Welfare at Work (Construction), Regulations S. I. 504 of 2006
- IR1 Form – Accident Report Form
- IR3 Form – Dangerous Occurrence Report Form

2.2.2 Fire Prevention in Buildings (electrical)

In relation to fire spread in buildings the National Rules for Electrical Installations ET101:2008 – 4th Edition lists requirements which are considered best practice in respect of the prevention of the products of combustion and smoke. These requirements must be adhered to in respect of the general duties of designers, manufacturers, importers and suppliers of articles and substances; see Section 16 of the Safety, Health and Welfare at Work Act 2005 No. 10 of 2005.

Fire Element	ET101:2008 Entry
Fire alarms	563.3.3
Fire barriers	521.2, 563.1
Fire hazards	105.422
agricultural areas	563.3
equipment	421
external influences	422
distribution boards	530.1
protective measures	422, 530.5.5, 521, 563
switching	539
wiring systems	521, 563
Fire-resistant cable	563.3
Fire-retardant cable	521.1
Fire-segregated areas	521.1
Fire-sealing	521.2
Fire-fighter's lift	564.3
Fire-fighter's switch	539.4, 559.14
Fire propagating structure	422.5

Table 2.2.1 – Fire Preventative Measures in ET101:2008

2.2.3 Physiological Effects of Fire on the Human Body

In pleasant surroundings, especially in daylight, it is difficult to fully accept that something, non-solid could kill or incapacitate you. Yet we usually accept the effects of anaesthetics in hospitals – a few whiffs of the gas and we are virtually dead to the world. When the operation is over the gas mixture is varied and we are allowed to wake. If we should be knocked unconscious in a fire situation there is no kind doctor hanging around to ensure that we awaken unless we are extremely fortunate. Most people are dead or unconscious as a result of breathing the fire gases before the severe heat or flames strike them – this can be a blessing in certain circumstances.

As people who may be responsible for the fire safety of others in an emergency situation we need to have some knowledge about these fire gases; what burning materials will give rise to these gases, how we are likely to detect such gases, and what effect the gases have on people

A description how the severe effects of gases can disable people is outlined below;

The effect is similar to a clamping force around the chest, a momentary inability to breathe, a strong fear of suffocating and a sense of deep physical weakness. Even if you are attempting to rescue children instincts take over and you will attempt to bolt or stampede to fresh air. In a serious fire situation the gases driven by thermal energy may move along corridors and up stairs at a speed equal to a fast walking pace of a physically fit young man.

Physiological effects of fire on people are caused by:

- (a) Breathing toxic gases and smoke;
- (b) Contact with flames and hot gases;

Main Toxic Gases

1. Carbon Monoxide
2. Carbon Dioxide
3. Hydrogen Chloride
4. Hydrogen Cyanide

1) Carbon Monoxide – Has a greater attraction for blood than blood has for oxygen and so interferes with the supply of oxygen to the brain. The nervous system is affected causing paralysis while the brain is still alert. ½ % of carbon monoxide in air causes rapid collapse. Average car exhaust gases contain 3% CO.

2) Carbon Dioxide – Small concentrations of carbon dioxide (CO₂) are used in surgery to promote deeper and faster breathing. This is an automatic reflex action and possibly the worse thing to happen in an area where there are toxic gases >10% CO₂ immediately hazardous to life.

3) Hydrogen Chloride (H.Cl) – Evolves from PVC upholstery, floor tiles and wall coverings. Causes sharp attack sensation in nose and throat. >1/100 % of H Cl in air is practically intolerable to breathe.

4) Hydrogen Cyanide (H CN) Produced from wool, silk and polyurethane foam > 1/40 % in air immediately fatal. >1/40 % confusion caused by brain damage, physical weakness, severe headaches.

Normally air contains 21% of oxygen – the remainder is nitrogen. In general oxygen is used up during combustion and the oxygen level falls below the 21% level.

Effects on Humans

12 – 16% - Increased pulse and breathing rate.

6 – 10% Nausea, vomiting, difficulty in moving about, faulty judgment and irrational conduct.

4 6% Survivors may suffer permanent brain damage.

Heat and Smoke and Burns

The effects can cause damage to the throat and lungs. Similarly, hot/wet gases more dangerous than hot, dry gases, which can cause pneumonia and survivors likely to have permanent damage to lungs. Above skin temperature of 43⁰C pain increases rapidly and victim may be unable to act rationally due to pain. Very badly burned victims may be in less pain than a lightly burned person – due to nerve ends being destroyed.

2.3.0 Introduction to Section 5

This section examines the roles of the Health and Safety Authority (I) and the Commission for Energy Regulation (CER) in respect of the regulation of the electricity activities in the Republic of Ireland.

2.5.1 Legislation and Guidance

While the use of electricity at work is regulated by several pieces of legislation, the specific piece of legislation where electricity is addressed most directly is in Part 3 (Regulation 74 to 93) of the 2007 Safety Health & Welfare at Work (General Application) Regulations. Comprehensive guidelines on these Regulations are available on the H.S.A. website

Core of this legislation is the risk assessment approach, and the legal duty on employers to ensure the safe interaction of his or her employees with all items associated with electricity.

While the use of electricity at work in respect of Potentially Explosive Atmospheres is regulated by several pieces of legislation, the specific piece of legislation where electricity is addressed most directly is in Part 8 (Regulation 167 to 175) of the 2007 Safety Health & Welfare at Work (General Application) Regulations.

2.5.2 Dangers associated with electricity

Working with electricity can be dangerous. Engineers, electricians, and other workers deal with electricity directly, including working on overhead lines, electrical installation and circuit assemblies. Others, such as office workers, farmers, and construction workers work with electricity indirectly and may also be exposed to electrical hazards.

2.5.3 Electro-Technical Council of Ireland (ETCI)

The Electro-Technical Council of Ireland Limited (ETCI) is a voluntary body of nineteen organisations representative of all aspects of electro-technology in the Republic of Ireland. Formally constituted in 1972, the Council is the national body responsible for the harmonisation of standards in the Electrotechnical field in collaboration with the National

Standards Authority of Ireland (NSAI). ETCI was incorporated as a company limited by guarantee in April 2000. The Company is registered with the Companies Registration Office, Dublin;

The governing body of ETCI is its Council which is comprised of one representative from each of the member organisations. ETCI operates through a process of consultation leading to consensus through the agency of a number of executive sub-committees and technical committees. The organisation chart shows the relationship between the Council of ETCI and its various committees. Contribution to ETCI is made at organisation level through full elected membership or by sectional interest in participating in the work of the relevant Technical Committee

The Electro-Technical Council of Ireland Limited (ETCI), is a voluntary body of nineteen organisations representative of all aspects of electro-technology in this country.. A representative from each of the nineteen organisations forms the Council of ETCI.

The Technical Management Committee (TMC) first introduced ETCI Manual of Procedures in 1997 with the aim of regularising ETCI activities and of standardising procedures. The purpose of these procedures is to equip members in understanding the modus operandi of ETCI.

ETCI has a range of publications which cater for the electrical safety requirements of the electrical industry in the Republic of Ireland, a visit to their publications section of their website is recommended; see web link below

2.5.4 Inspection and Testing of Installations

The Safety Health & Welfare at Work (General-Application-Regulations) 2007 sets out general duties for the testing of new and existing installations Regulation 89 of the legislation states;

“An employer shall ensure that”

(a) a new electrical installation and a major alteration of, or extension to, an existing electrical installation is, after completion, inspected and tested by a competent person

(b) an existing electrical installation is tested by a competent person in an appropriate manner—

(i) from time to time where required having regard to the nature, location and use of the installation, or

(ii) if an inspector so requires, and a report of the test is completed by the competent person carrying out the test,

(d) all defects found during the testing and inspection of an electrical installation are rectified promptly so as to prevent danger.

Testing and certification should only be carried out by persons competent to do so.

Every new installation and every major alteration or extension to an existing installation, after completion and before being made live, must be inspected and tested so as to verify that the requirements of this part of the Regulations have been fulfilled. However, certain types of test may only be made after an installation has been made live. All the appropriate information, including diagrams of connections, wiring diagrams, charts, tables, schedules, equipment ratings and the like, must be available to the person or persons carrying out the verification. Precautions must be taken to ensure the safety of persons and to avoid damage to the installation and equipment during inspection and testing.

Where the installation is an extension or alteration of an existing installation, it must be verified that the extension or alteration complies with this part of the Regulations and does not impair the safety of the existing installation.

2.5.5 Commission for Energy Regulation (CER)

In addition to the Health and Safety Authority (H.S.A.), the Commission for Energy Regulation (C.E.R.) has a key role in regulating the safety of all electrical installations. Unlike the H.S.A., the CER regulates installations in domestic as well as workplace environments. Following the enactment of the Energy (Miscellaneous Provisions) Act 2006 in December 2006, the CER's functions were expanded in a number of areas. Significantly, the 2006 Act assigns the Commission responsibility for the regulation of electrical contractors with respect to safety. In accordance with the 2006 Energy (Miscellaneous

Provisions) Act, the CER is allowed designate bodies to carry out its function to monitor contractors.

The Commission has now concluded the designation process and has appointed both the Electrical and the Register of Electrical Contractors of Ireland (RECI) to carry out the function of regulating electrical contractors on its behalf. Both designated bodies are required to carry out this new function for seven years. Both designated bodies will be subject to ongoing audit and inspection to verify compliance with the requirements of the legislation.

Pursuant to the enactment of the Energy (Miscellaneous Provisions) Bill in 2006, the CER was given the statutory authority to “regulate the activities of electrical contractors with respect to safety”. In order to carry out the day to day operation of the scheme, the CER proposed to appoint party/parties to act as an electrical Safety Supervisory Body.

Following the completion of a formal designation process, both the Electrical Contractors Safety & Standards Association Ireland Ltd (ECSSAI Ltd) and the Registered Electrical Contractors of Ireland Ltd (RECI Ltd) were appointed in 2008, as electrical Safety Supervisory Bodies by the CER.

Both Safety Supervisory Bodies are required to fulfil the safety function on behalf of the CER (on a not-for-profit basis) for a period of seven years, whilst the CER remains responsible for policy decisions regarding electrical safety. The operation of the statutory regulatory framework for electrical safety by the CER commenced on the 5th of January 2009, replacing the self-regulatory model operated previously by both RECI and ECSSA (now ECSSAI).



Figure 2.5.2 – Safe Electric Logo

2.5.6 Role of the Safety Supervisory Bodies (SSB's)

In November 2008 the CER appointed the Electrical Contractors Safety & Standards Association (Ireland) Ltd (ECSSA Ltd) and the Register of Electrical Contractors of Ireland Ltd (RECI Ltd) as electrical safety supervisory bodies. Both bodies are responsible for the regulation of the activities of Registered Electrical Contractors and are carrying out this function on behalf of the CER.

Both RECI and ECSSAI are required to comply with the requirements as stated within the Criteria Document, which include the following:

1. Receipt, processing and evaluation of Applications for Registration;
2. Registration of electrical contractors and publication of a Register of Electrical Contractors;
3. Monitoring, Inspection and Audit of electrical contractors registered with the Body;
4. Investigation of complaints received and the disciplining of electrical contractors registered with the Body;
5. Inspection of works of Third Parties;
6. Management of the distribution, sale, recording, control and the validation of Certificates;
7. Public and industry awareness activities;
8. Interaction and co-ordination of activities with other Bodies and such other agencies, bodies, committees and Government Departments, as the Commission may direct from time to time;
9. Maintaining records of, and reporting on, the activities of the Body;
10. The operation, and use, of the Brand in accordance with the requirements specified by the Commission.

2.5.7 Regulatory Framework

The CER published a Vision Document (CER/07/203) in 2007, which provided a blueprint for the creation of the regulatory model for electrical safety. Subsequent to the publication of the Vision Document, the CER published the 2008 Criteria Document (CER/08/071), which detailed the rules and obligations for participants operating within the electrical safety regulatory framework.

A central part of the electrical safety framework is the concept of Regulated Electrical Works. Essentially, Regulated Electrical Works require the issuance of a Certificate by a Registered Electrical Contractor (see the Controlled and Restricted Works sections for further details).

When engaging the services of a Registered Electrical Contractor to complete a Regulated Electrical Work, the consumer is entitled to receive a Certificate, which confirms that appropriate safety tests have been carried out on the installation and that the electrical installation is safe.

2.5.8 The Criteria Document consists of a series of Common Procedures

The Criteria Document is fundamental to the operation of the electrical safety regulatory framework, as it sets out the rules and responsibilities of stakeholders involved in electrical safety including the Safety Supervisory Bodies and Registered Electrical Contractors, whilst also outlining the disciplinary and appeals process for Registered Electrical Contractors.

1. **Certification:** The Certification Common Procedure outlines the process to be followed by Safety Supervisory Bodies, Registered Electrical Contractors and the Distribution System Operator during the certification of an electrical installation.
2. **Third Party Inspections:** The provision of the Third Party Inspection service by the SSBs is designed to facilitate the Certification of Controlled Works carried out by Non-Registered Electrical Contractors.
3. **Change of Contractor:** A Change of Contractor event refers to a situation whereby a customer requires another contractor to complete and/or certify an electrical installation, which was partially or totally completed, by a different contractor.

4. **Transfer of Registrations:** The Transfer of Registration Common Procedure details the process for transferring Registered Electrical Contractors details when switching Safety Supervisory Bodies.
5. **Enforcement:** details the role of the Safety Supervisory Body, the Registered Electrical Contractor, ESB Networks and the customer in ensuring electrical safety.
6. **Modifications:** details the process for making modifications to the Criteria Document.

2.5.9 Qualified Certifier's Requirements

Section C – 1.2.7 be a principal or employee of the REC who is available on a fulltime basis;

(ii) be an electrically-competent person, satisfying the criteria specified in Clauses 1.2.13 to 1.2.15 (Training and Competence of Qualified Certifier), responsible for, on a day-to-day basis, the safety, quality and certification of the electrical installation works of the REC with regard to the Technical Rules;

(iii) be a party who may carry out Certification on behalf of the REC;

(iv) be responsible for safeguarding unused Certificates in their possession against loss, theft and/or unauthorised use;

(v) ensure that results of Inspection and testing are properly recorded on the appropriate prescribed forms of Certification and reporting, and reviews and confirms the results for compliance with the Technical Rules;

(vi) complete up-to-date training courses as specified by the Body (failure to complete required training courses without reasonable cause may result in the person being in breach of the requirements of this section and, therefore, they shall not be entitled to act as Qualified Certifier); and (vii) is required to have successfully completed a recognised course in “Testing, Verification and Certification” in the previous three (3) years.

2.5.10 National Rules for Electrical Installations ET101:2008

The Electro-Technical Council of Ireland (ETCI) produces a full set of rules for Electrical Installations. These give a comprehensive set of requirements for the electrical engineering requirements for the electrical installations at voltages of 400 Volt AC. An updated 4th edition of this document was published in 2008. The standards set out in these rules should be applied for all new installations under construction and all extensions.

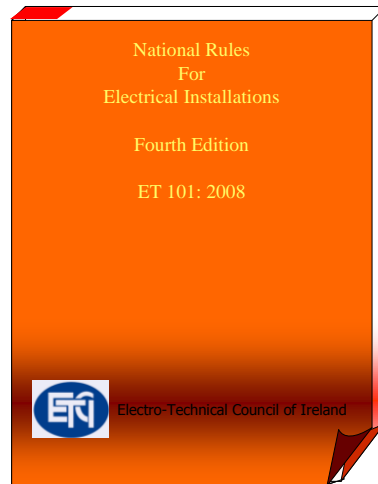

Figure 2.5.3 – National Rules for Electrical Installations – ET101:2008

The testing requirements for installations are also set out and should be applied when carrying out inspection and testing in accordance with the 2007 General Application Regulations. Among the areas updated in the new wiring Regulations are sections on agriculture, temporary structures (such as marquees and fairgrounds) bathrooms and several others. In addition, the regulations set out a revised structure for certification and testing of installations, which should be adhered to. If you are commissioning an electrical works in your premises, then you should check and specify that the installation is being carried out in accordance with the up to date Wiring Regulations.

National Rules for Electrical Installations

(Reference to Chapters, Sections, Paragraphs, Tables and Annexes correspond to those contained in the National Rules for Electrical Installations, Fourth Edition ET101:2008.

This summary of the Rules, based on the Fourth Edition, lays down the requirements for the design, erection and proper functioning of electrical installations so as to ensure safety of persons, livestock and property against dangers and damage that may arise in the reasonable use of electrical installations.

Scope

These Rules apply to electrical circuits supplied at nominal voltages up to and including 1000V a.c. or 1500V d.c. which form part of installations in residential, commercial, industrial or public premises, or of installations contained in prefabricated buildings, caravans and halting sites, as well as installations for specialised purposes, such as those in agricultural and horticultural holdings.

They do not apply to electrical equipment for traction in automobiles or aircraft or on board ships, to installations in mines and quarries, systems for distribution of electrical energy to the public, power generation or transmission for such systems, radio interference suppression equipment or lightning protection of buildings.

The ETCI, as the Irish National Committee of CENELEC, the European Committee for Electrotechnical Standardisation, participates in the work of harmonising the rules for electrical installations which must be implemented by all countries concerned. More than half of the technical content of the Rules is now harmonised throughout the CENELEC region.

The Rules format is in line with is the European format comprising of seven distinct sections as shown below;

Part 1 Scope, Object and Fundamental Principles

Part 2 Definitions

Part 3 General Characteristics

Part 4 Protection for Safety

Part 5 Selection and Erection of Equipment

Part 6 Verification and Certification

Part 7 Requirements for Special Installations of Locations

Part 4 contains the fundamentals of safety for installations. These include measures for protection against shock, earthing, thermal effects generated by installations, short-circuits, overloads, fire and earth faults.

Part 5 contains the practical requirements for design and construction of installations. These include comprehensive rules for wiring systems and a substantial set of tables giving current ratings for various types of cables in differing situations. Earthing and bonding are covered.

Part 6 specifies the tests that must be carried out on the completed installation in order to verify compliance.

Part 7 contains rules for special situations – bathrooms, swimming pools, saunas, farms, earthing of IT equipment, caravans and caravan parks.

Fundamental Principles for Safety of Electrical Installations

These Rules are intended to protect persons, livestock and property against risks arising from the reasonable use of electrical installations, particularly against shock currents and excessive temperatures likely to cause fires, burns and other injurious effects, including risks of physical injury from electrically-driven mechanical equipment

2.5.11 National Rules for Electrical Installations in Potentially Explosive Atmospheres ET105:2011

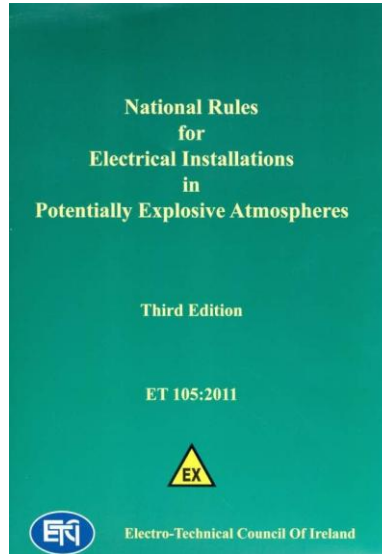

Figure 2.5.4 – National Rules for Electrical Installations in Potentially Explosive Atmospheres – ET105:2011

Electro-Technical Council of Ireland (ETCI) Technical Committee 6 (Equipment for Potentially Explosive Atmospheres) has prepared the National Rules for Potentially Explosive Atmospheres, ET105. This publication specifies the requirements for electrical installations in potentially explosive atmospheres. This Edition replaces the Second Edition.

The ETCI Technical Group 6 (TC6) are in the process of a revising ET105 to update and bring it to present national and international practice coordinating the publication with the provisions of the Fourth Edition of the National Rules for Electrical Installations (ET 101: 2008) and the legal requirements of the Safety, Health and Welfare at Work (General Application) Regulations (S.I.2999 of 2007)

The TC6 have also undertaken another revision in the area of Subsystem Completion of Certificates and Test Records for Electrical Installations in Potentially Explosive Atmospheres. The Implementation for the new Rules is 3rd January 2012. At that point the National Rules for Electrical Installations in Potentially Explosive Atmospheres the Second Edition and ET105:2001 will be withdrawn on this date.

Chapter Three

Objectives

3.1 Chapter Three – Objectives of the Study

The objectives of the study were as follows:

1. To determine to what extent the impact of the quality of Verification and Testing process on Electrical Installations is having in terms of electrical safety and the prevention fire spread within Electrical Installations in domestic premises.
2. To develop a series of questionnaires to assess, from a quantitative and qualitative perspective the primary concerns of practitioner's in the electrical services industry; to carry out a series of surveys to ascertain the concerns and views of the following:
 - (i) Phase 4 and Phase 6 Standards-Based Apprenticeship (electrical) apprentices
 - (ii) Registered electrical contractors
 - (iii) Measurement of the performance of pre-connection and post-connection tests of domestic electrical installations.
3. Perform an analysis of the questionnaire results with special interest on the views and attitudes of students; registered electrical contractors and performance indicators of the current trends in respect the electrical safety in domestic electrical installations.

Chapter Four

Methodology

4.1 Chapter Four – Details of Study

The focus of the study is to carry out an investigation of the efficiency of verification and testing of electrical installations in domestic premises in Ireland.

It was decided to take a holistic approach to this important topic; following discussions with members of staff in the Dublin Institute of Technology, School of Electrical Engineering Systems and in particular the Department of Electrical Services Engineering (DESE). It was decided to use the links with DESE;

DESE have been directly involved in craft education and training since before the first-world-war WWI. An examination of the Standards-Based Apprenticeship (electrical) reveals that verification and inspection of electrical is mentioned in the following sections of the syllabus

Standards-Based Apprenticeship stages:

Phase 2	Phase 3	, Phase 4	Phase 5	Phase 6
---------	---------	-----------	---------	---------

4.2 The Objectives of the Study

1. The objectives of the study were as follows:

To determine to what extent the impact of the quality of Verification and testing process on Electrical Installations is having in terms of electrical safety and the prevention fire spread within Electrical Installations in domestic premises.

2. To develop a series of questionnaires to assess, from a quantitative and qualitative perspective the primary concerns of practitioner's in the electrical services industry; to carry out a series of surveys to ascertain the concerns and views of the following:

- (i) (Phase 4 and Phase 6 Standards-Based Apprenticeship (electrical) apprentices
- (ii) Registered electrical contractors
- (iii) (Measurement of the performance of pre-connection and post-connection tests of domestic electrical installations.

3. Perform an analysis of the questionnaire results with special interest on the views and attitudes of students; registered electrical contractors and performance indicators of the current trends in respect the electrical safety in domestic electrical installations.

4.3 Verification and testing Phase 4 Module

The Department of Electrical Services Engineering (DESE) in DIT Kevin Street college are directly involved with the Phase 4 and Phase 6 in which the practical aspects of the verification and testing are specifically mentioned in the Phase 4 syllabus.

For the purposes of educational administration the Phase 4 syllabus is divided into various sections; an examination of Electrical Craft Theory 7 – Unit 4.2.7 deals with the Testing and Verification of electrical installations (practical) see page(s) 45 and 46 of the Phase 4 syllabus.

Earthing and testing is also catered for in the measurements laboratory Module 2 – Power Distribution 1 see page 45 of the Phase 4 Syllabus

4.4 Verification and testing Phase 6 Module

If a search is conducted on the Phase 6 syllabus 16 entries can accessed, they are listed; the main areas relating to verification and testing are contained in the following:

- I. Electrical Craft Practice – Earthing and testing, Module 4, Unit 3
- II. Measurements Laboratory – Earthing, Verification and Testing, Module 4, Unit 3

Since verification and testing is a fundamental part of the electrical installation process, DESE has invested in the production of specialist test-rigs with the facility of demonstrating the various tests; testing can be hazardous, both to the tester and to others who are within the area of the installation during the test. The danger is compounded if a sequence or approach to the tests is not adhered to. For example, the continuity, and in particular the effectiveness, of protective conductors must be confirmed prior to the insulation resistance test. The high voltage used for insulation testing could appear on all extraneous metalwork associated with the installation in the event of an open-circuit protective conductor if insulation resistance is very low.

Also, the earth-fault loop impedance test cannot be conducted before an installation is connected to the supply. The danger associated with such a connection before verifying polarity, protective system effectiveness and insulation resistance should be obvious. Any test which fails to produce an acceptable result must be repeated after remedial action has been taken and if such failures impact on previously performed tests, they must be repeated to affirm the integrity of associated results.

The following tests

Pre-Connection of the Supply	
1	Continuity of protective conductors and Bonding Conductors
2	Continuity of ring final circuit conductors
3	Resistance of the Earth Electrode
4	Resistance of the Protective Conductor
5	Insulation Resistance of Cables and Insulated Wires
6	Polarity Tests

Table 4.4.1 – Pre connection Tests

Post-Connection of the Supply	
7	Fault Loop Impedance Tests
8	Verification of Operation of Residual Current Devices
9	Correct operation of residual current devices
10	Correct operation of switches and isolators

Table 4.4.2 – Post connection Tests

4.5 Survey of Electrical Apprentices Phase 6 Students

The first part of methodology consisted of carrying out an Electrical Safety Survey in May 2012 involving Phase 6 students who were attending their Standards-Based Apprenticeship and to elicit their views on the verification and testing process. 112 Respondents were surveyed using the Turning Point Clicker response device system undertaken over the Academic year.

This enabled respondents to answer the questions on a controlled anonymous basis non intimidated environment) Covering basics of checks covering visual, installation practice & theory.

Ref:	Academic Topic
Q1	Importance of retesting a domestic installation
Q2	Frequency of retesting domestic dwellings
Q3	General Services & Disconnection
Q4	General Services & max fault loop impedance
Q5	Main post-connection tests of an installation
Q6	ET101:2008 & Safety Requirements within Bathrooms
Q7	ET101 & Safety Requirements of Distribution Boards
Q8	Types of Earthing System (TNC-S)
Q9	Did you complete Phase 2 at a Fás Training Centre?
Q10	What IT College did you complete SBE Phase 4?

Table 4.5.1 – Survey Questions

4.6 Ethical considerations

Ethical recommendations regarding research activity involving human participants were complied with, in terms of informed consent, confidentiality of personal information and medical confidentiality. The requirements of the Data Protection Act 1988, No. 35 of 1988 and the Freedom of Information Act 1997, No. 13 of 1997 and any amendments to these acts, was complied with. The design, distribution and analysis of the questionnaire were conducted in such a way that anonymity was assured.

In order to ensure anonymity some of the questions 9 and 10 were regarded as spurious as it might be possible to trace the identity of some of the students.

4.7 An introduction to primary data collection

The most commonly used primary data collection methods include: extensive interviews, intensive interviews, focus group sessions, and primary document analysis, extensive interviews are otherwise known as surveys (B.Phillips, 1971)Surveys are generally used to obtain data on a trend or opinion within a large, relatively homogenous population. Most questions on a survey are close ended, ranked questions (Fink, 1995). Intensive interviews are conducted on a one-on-one basis, generally using open-ended questions, in order to maintain a conversational flow (Seidman, 1998).

Intensive interviews are conducted with key informants, such as professionals in a field, or regular informants, which are usually general members of the study population. Focus groups are similar to intensive interviews, but they are conducted within groups of eight to ten key informants or regular informants. Focus groups are often used to identify issues of concern within a study population to guide the scope and focus of the researcher (Singleton, 1998).

Survey distribution in the form of a questionnaire was the chosen method of primary data collection for this study. The distribution of the questionnaire was chosen to acquire data on trends within the study population.

4.8 Assumptions with Primary Data

A number of assumptions were made as follows:

1. The survey was carried out assuming that there was 100% attendance on the day; this will lead to a statistical error as it is unlikely that there was no absenteeism on the day of the surveys.
2. Since five values were available to the students e.g. 1.5 Ω , 0.5 Ω , 0.05 Ω , 5 Ω and None; there is a chance that some of the students would simply guess the correct answer; this would reduce the probability of a student being correct to a ratio of 1:4 of 80% which is 20%
3. During conversion of percentages in Table No. 4A to actual student numbers in Table No. 4B rounding occurred which gives a larger number of students; if there were no absentees there would be 112 students this is because there are 16 students per class ($7 \times 16 = 112$).
4. There is ambiguity in the question; Question No 4 – When checking a 20A C Type MCB on a domestic socket circuits what is the maximum value of fault loop impedance?
5. A comparison of the two graphs Figure No. 4A and Figure No. 4B shows a slight variation in the data this can be explained by the methodology uses in taking the data in Table No. 4 which is percentages format; take a figure of 43% of 32 students; the number of students is obtained by the following methodology (32×0.43) = 13.76 this number is rounded up to become 14 since there is no such thing as 0.76 of a student (see figures shown in blue). Similarly rounding down occurs when the number is below 0.5.

Chapter 5 – Analysis and results shows Tables and Graphs which contain raw and cleansed data which endeavours to take some of the assumptions into account.

4.9 Questionnaire and Data composition

The questionnaire has in effect 9 questions in total and took approximately 35 minutes to complete, and based on fundamentals of combining qualitative and quantitative methods (Morgan, D.L. 1998) the questionnaire was designed so that the responses were close-ended and categorical in nature and were qualitative in nature and intended to elicit personal opinions and experiences, the questionnaire was designed to show patterns or trends if they were relevant to the focus of the study. The results are contained in Chapter 5 of this study.

4.10 Survey of Registered Electrical Contractors

Objective number two was to ascertain the views of Registered Electrical Contractors (REC) who are members of the Electrical Contractors Safety & Standards Association (ECSSAI) and Register of Electrical Contractors of Ireland (RECI).

The survey was carried out with a questionnaire containing 20 questions:

- 14 questions were quantitative in nature – 70%
- 6 questions were qualitative – 30%

The purpose of the questionnaire was to elicit the opinions and views of Registered Electrical Contractors in respect Verification and Testing of Electrical Installations in the Republic of Ireland.

Letters were sent out the SSB seeking their help and support (see Appendix A for details of letters and questionnaire).



Figure 4.10.1 – Safety Supervisory bodies

4.11 Questionnaire distribution

The survey was in the form of an electronic questionnaire; the questionnaire was distributed through the web-site of the register of Electrical Contractors of Ireland



The screenshot shows the website of the Register of Electrical Contractors of Ireland (RECI) on Thursday, June 14, 2012. The page features the RECI logo and the 'SAFE ELECTRIC' logo. A navigation menu includes Home, Contractor Services, Consumer Services, Latest News, and Contact Us. The main content area displays a news item titled '21 May 2012: Survey in respect of Verification & Testing of Electrical Installations in the Republic of Ireland'. The text of the news item describes a survey conducted by Noel Masterson, a member of staff in the School of Electrical Engineering Systems, Department of Electrical Services Engineering, DIT Kevin Street, Dublin 8. The survey aims to determine the extent and effectiveness of the verification and testing process for electrical installations. The questionnaire is designed to be completed in approximately 25 minutes and is strictly confidential and anonymous. It can be completed online or downloaded and returned by post. The survey results will form part of the requirements for a Master of Science in Environmental Health and Risk Management at the Dublin Institute of Technology.

Find An Electrician
If you are looking for an Electrician click here.

BESS Register
Click here to access the Register.

RGII
Register of Gas Installers of Ireland
Go to web site >

21 May 2012: Survey in respect of Verification & Testing of Electrical Installations in the Republic of Ireland

Noel Masterson, a member of staff in the School of Electrical Engineering Systems, Department of Electrical Services Engineering, DIT Kevin Street, Dublin 8, is undertaking a survey into :

"Verification and Testing of Electrical Installations in the Republic of Ireland"

The results of the research will form part of the requirements for a Master of Science in Environmental Health and Risk Management - Dublin Institute of Technology.

The primary objective of the research is to determine to what extent the process of verification and testing of electrical installations is carried out and the effectiveness of the testing process.

The survey will attempt to capture the perceptions and the views of Registered Electrical Contractors on this important topic.

The questionnaire was designed for ease of completion while at the same time collecting the maximum data, it should take approximately 25 minutes to complete. We would be grateful if you could take the time to complete and return the questionnaire at your soonest convenience (by early June if possible).

The questionnaire itself is strictly confidential and anonymous; the participant's identification will not appear on the questionnaire.

The questionnaire can be completed online by clicking **here**. Alternatively the questionnaire can be downloaded by clicking **here**. You can then, print it and return the filled-in questionnaire to the address specified on the first page.

Thank you for your help and co-operation.

Figure 4.10.2 – Register of Electrical Contractors of Ireland

Results of the survey are contained in Chapter 5 of this study.

4.11.2 Domestic Electrical Installations Housing Data.

The data obtained from the audits was collated and for consistency and validity using several software programmes, Adobe Life Cycle, MS Excel and finally SPSS were used to process and configure the data.

A data sheet was in set up in Adobe Life Cycle for ease of distribution and collection. (See fig 4.11.1)

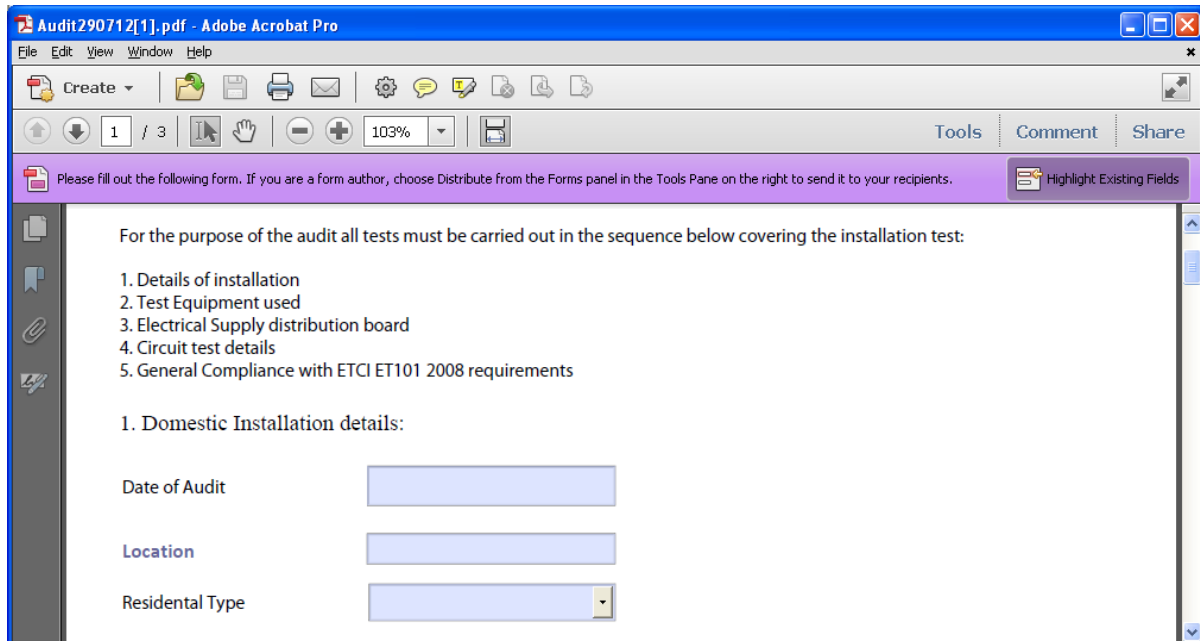

The screenshot shows the Adobe Acrobat Pro interface with a PDF form open. The form title is 'Audit290712[1].pdf'. The toolbar includes 'File', 'Edit', 'View', 'Window', and 'Help'. The main content area contains the following text:

Please fill out the following form. If you are a form author, choose Distribute from the Forms panel in the Tools Pane on the right to send it to your recipients.

For the purpose of the audit all tests must be carried out in the sequence below covering the installation test:

1. Details of installation
2. Test Equipment used
3. Electrical Supply distribution board
4. Circuit test details
5. General Compliance with ETCI ET101 2008 requirements

1. Domestic Installation details:

Date of Audit

Location

Residential Type

Figure 4.11.1 – Adobe Life Cycle Data Sheet

The audit test sequence is shown below covering the installation test;

1. Details of installation all tests must be carried out in
2. Test Equipment used
3. Electrical Supply distribution board
4. Circuit test details
5. General Compliance with ETCI ET101 2008 requirements

Each form was completed and submitted Adobe package and the form was reengineered to be then exported and processed by the SPSS statistics package, the programme selected too best review and interrogate the results.

The datasheets for all the audits were then exported to Adobe Formcentral grid as seen in fig.4.11.2

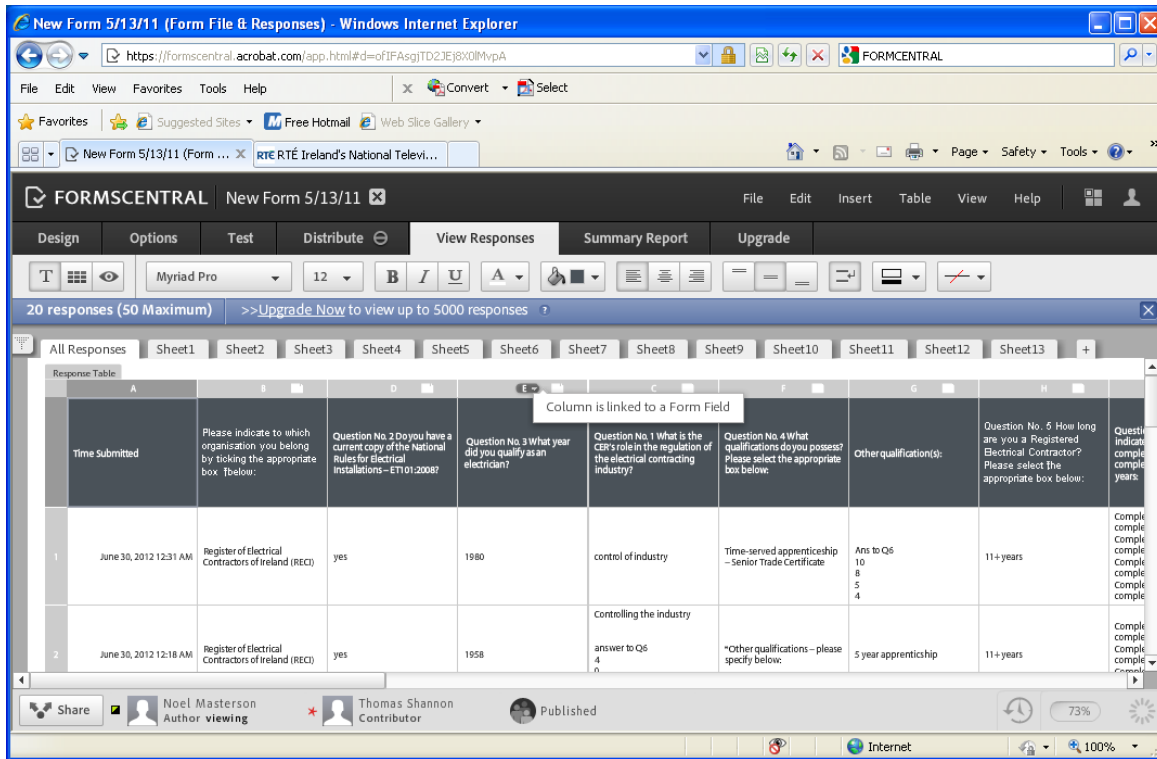

Figure 4.11.2 – Adobe Formcentral grid

The responses were prebuilt in the programme which allowed easy export to MS Excel the information from the tests was quite varied and for the reader to understand the documented information the naming convention of each step was vital for comprehension of the overall study.

Chapter Five

Analysis and Results

Chapter Five – Questions Analysis and Results

Ref:	Academic Topic
Q1	Importance of retesting a domestic installation
Q2	Frequency of retesting domestic dwellings
Q3	General Services & Disconnection
Q4	General Services & max fault loop impedance
Q5	Main post-connection tests of an installation
Q6	ET101:2008 & Safety Requirements within Bathrooms
Q7	ET101 & Safety Requirements of Distribution Boards
Q8	Types of Earthing System (TNC-S)
Q9	Did you complete Phase 2 at a Fás Training Centre?
Q10	What IT College did you complete SBE Phase 4?

5.1 Chapter Five –Q1 Importance of retesting a domestic installation

2010/2011	Class	Important	Not Reqd.	No Opinion	Total
Semester 1	6A & B	57	32	11	100
Semester 1	6C & D	90	10	0	100
Semester 2	6A & B	79	21	0	100
Semester 2	6C	97	0	3	100
Total		323	63	14	400
Percent %		80.75	15.75	3.5	

Table 5.1.1 – Response to question No. 1 – Raw data

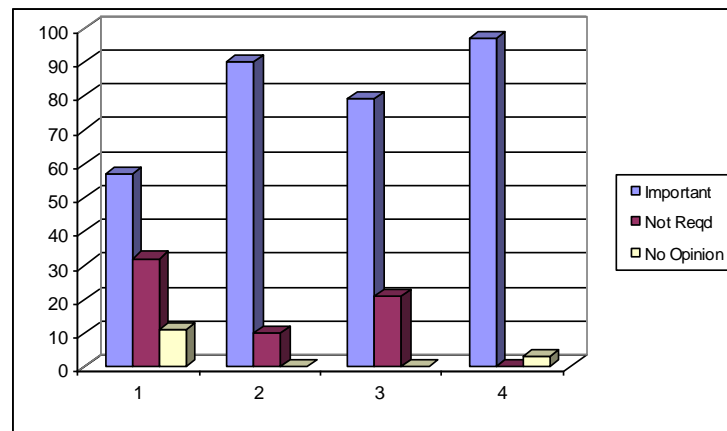

Figure 5.1.1 – Response to question No. 1 – Raw data

Guidelines for testing and certification and alteration of existing electrical installations are provided in Annex 63B of the National Rules for Electrical Installations – ET101:2008 4th Edition.

Clause 611.5 of the Rules states “It shall be verified that an extension, addition or alteration to an existing installation complies with the Rules, and that it does not impair the safety of that installation, and that the safety of the new installation is not impaired by the existing installation”. These Guidelines are intended to explain the necessary procedures that should be followed by the installer.

Basic principles

New work must comply with the current Rules. Before commencing new work, the installer should assess the existing installation to ensure that it will not impair the safety of the proposed new work, and likewise that the new work will not impair the safety of the existing installation.

Should the installer become aware of any defect in any part of the installation that would impair the safety of the new work, the client must be informed in writing thereof. No new work should commence until these defects have been made good.

Classification of New Work

For the purposes of this Annex, new work comprising alterations to an existing installation is classified as follows:

A) Major alteration to an existing installation, requiring a completion certificate to be provided by the installer and given to the client.

Major alteration includes the following:

1. An extension: The provision of one or more additional circuits.
2. Replacement of a distribution board.
3. Replacement of the wiring for a circuit.
4. Replacement of a protective device.
5. Relocation of a distribution board.

B). Minor alteration to an existing installation, requiring a Declaration of Compliance when requested by the client.

Minor alteration includes the following:

1. Addition to an existing circuit of an accessory or similar item e.g. a socket-outlet, a wall-switch or a lighting outlet.
2. Replacement of an accessory or similar item e.g. a socket-outlet, a wall-switch or a lighting outlet.
3. Relocation of an accessory or similar item e.g. a socket-outlet, a wall-switch or a lighting outlet

C) Loading

Where an extension is planned, the installer should ensure that the main supply wiring and the distribution board have sufficient capacity to carry the total load including any additional load due to the extension or addition.

Distribution Boards

4.1 Replacement

Where a distribution board is to be replaced, it should comply with the following:

1. clause 530.5 of these Rules, and
2. Where applicable, ET 205: “Code of Practice for the Design, Selection and Erection of LV Distribution Boards for Residential Applications.

All protective devices fitted to the replacement distribution board should be correctly selected to provide the required protection for existing circuits and any new circuits, in accordance with the current Rules. This should be verified in the same way as for a new installation, i.e. by tests for fault-loop impedance and RCD operation as specified in Chapter 61 of the Rules.

The conductors connecting the replacement board to the incoming supply should be of at least 16 mm² copper; replacement may be necessary. The main bonding conductors and main protective conductors should be checked for compliance with the Rules and replaced where necessary.

Cables and their terminations should be checked for signs of damage, e.g. heat or mechanical damage, and replaced where necessary.

4.2 Relocation

Where a distribution board is to be relocated, cables should be checked for signs of damage and replaced where necessary.

4.3 Wiring

Where replacement of wiring is necessary due to the replacement or relocation of a distribution board, the new work is deemed to be equivalent to an extension.

5. Minor Alteration

When replacing or relocating an accessory or similar items, cables and their terminations should be checked for signs of damage and replaced where necessary. It is recommended that where relocation is intended, the item should be replaced.

6. Testing

New work must be tested in accordance with Chapter 61 of the Rules.

7. Certification or Declaration of Compliance

Documentation should be prepared by the installer for all new work as follows:

- for a major alteration, a completion certificate Type 1 or Type 2 in accordance with Annex 63A,
- for a minor alteration, a Declaration of Compliance for Minor Electrical Works.

All entries on the Completion Certificate or Declaration of Compliance should be filled in by the installing electrical contractor MPRN is the Meter Point Reference Number of the installation.

The tests are those relating to the new work and the parts of the existing installation that are relevant to the new work. A copy of the certificate or declaration of compliance should be given to the client as an assurance that the new work complies with the current edition of the Rules. A Declaration of Compliance may not be used to obtain an electricity supply from the DSO.

Test Record Sheets

Test record sheets should be completed by the installer and held in his or her records.

2010/2011	Class	Important	Not Reqd.	No Opinion	Total
Semester 1	6A & B	18	10	4	32
Semester 1	6C & D	29	3	0	32
Semester 2	6A & B	25	7	0	32
Semester 2	6C	15	0	1	16
Total		87	20	5	112
Percent %		77.68	17.86	4.46	

Table 5.1.2 – Response to question No. 1 – cleansed data

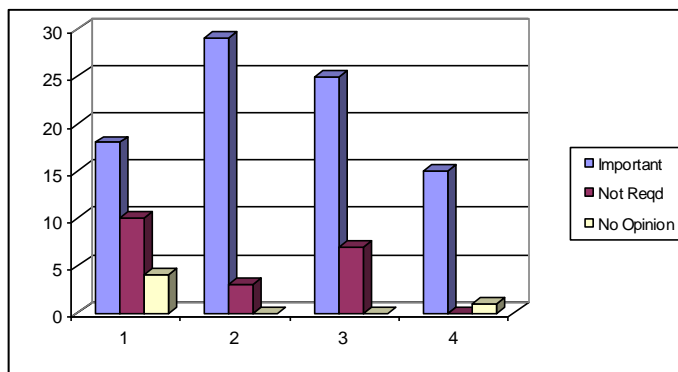

Figure 5.1.2 – Response to question No. 1 – Cleansed data

82.14% of respondents were correct, 17.86% were incorrect re-testing is required to satisfy the requirements of the National Rules for Electrical Installations – ET101;2008 4TH Edition.(See Annex 63B (pages 328 and 329)

Virtually all electrical work carried out in a domestic installation requires re-testing, see details below:

1Major alteration

2Minor alteration

3Additional loading

4Alteration to a distribution board

5Relocation of a distribution board

6 Other

5.2 Q2 what is the current required Frequency of retesting domestic dwellings

		2 years	5 years	10 years	20 years	Not Reqd.	Total
Semester 1	6A & B	7	11	4	4	75	101
Semester 1	6C & D	16	42	29	3	10	100
Semester 2	6A & B	0	7	0	0	93	100
Semester 2	6C	24	31	10	3	31	99
Total		47	91	43	10	209	400
Percent %		11.75	22.75	10.75	2.5	52.25	100

Table 5.2.1 – Response to question No. 2 – Raw data

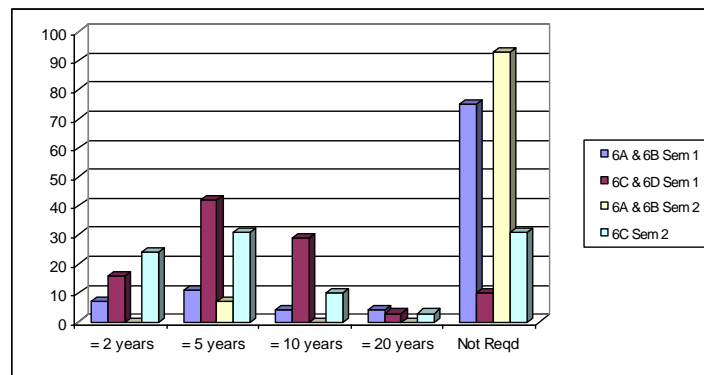

Figure 5.2.1 – Response to question No. 2 – Raw data

The National Rules for Electrical Installations – ET101:2008 4th Edition the criteria relating to testing of an electrical installation is very clear, and is catered for in Part 6 of ET 101:2008.

Part 6 is divided into three chapters as follows:

3. Chapter 61: Initial Verification
4. Chapter 62: Periodic Inspection and Testing
5. Chapter 63 :Certification

The frequency of retesting of an electrical domestic installation; the selection available to participants:

1. 2 years
2. 5 years
3. 10 years
4. 20 years
5. Not Required

The majority of the students 52.25% opted for the apparently correct response. This is not a simple question since it depends on the functionality of the domestic electrical installation. In respect of a private dwelling the response is correct; 47.75% of respondents were incorrect.

2010/2011	Class	2 years	5 years	10 years	20 years	Not Reqd.	Total
Semester 1	6A & B	2	4	1	1	24	32
Semester 1	6C & D	5	13	9	1	4	32
Semester 2	6A & B	0	2	0	0	29.76	32
Semester 2	6C	4	5	2	0	5	16
Total		11	24	12	2	62.76	112
Percent %		9.82	21.64	10.71	1.79	56.04	100

N = 112 – 52.2% answered correctly; 47.75% answered incorrectly - *rounding normally 16 students per class group

Table 5.2.2 – Response to question No. 2 – Cleansed data

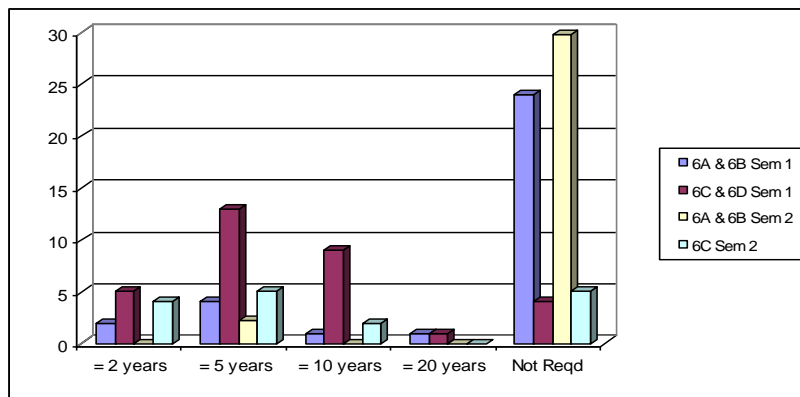

Figure 5.2.2 – Response to question No. 2 – Cleansed data

In the case of a domestic dwelling which is used for Rented Accommodation there are minimum standards as set out below:

The Residential Tenancies Act 2004

The Residential Tenancies Act 2004 introduced a major reform of landlord and tenant legislation and the quality and choice of rental accommodation has improved generally in line with the huge investment in new accommodation. The progress made in the development and regulation of the private residential rented sector has made it more attractive both to those seeking housing and to

accommodation providers; however, the elimination of substandard accommodation, particularly from the lower end of the rental market remains a critical step in achieving a well balanced housing market in which renting is seen as a viable and attractive long term housing option.

Regulations setting out minimum standards for private rented accommodation generally were first set out in the Housing (Standards for Rented Houses) Regulations 1993. However it became clear in recent years that these standards no longer reflected the requirements of the modern rental sector and in the Partnership Agreement *Towards 2016*, the Government committed to updating and effectively enforcing the minimum standards regulations for rented houses in order that they should reflect the general quality of life improvements over the last number of years.

Regulatory Framework

In September 2006, the Department of the Environment, Heritage and Local Government launched the programme *Action on Private Rented Accommodation Standards*. Arising out of this programme new regulations prescribing minimum standards for rented housing, the Housing (Standards for Rented Houses) Regulations 2008 (S.I. 534/2008), came into effect on the 1st of February 2009 with certain provisions being phased in for existing r^{en}tal properties over a 4 year period.

A number of further measures, including a strengthened sanctions regime, required primary legislation and this was delivered by means of the Housing (Miscellaneous Provisions) Act 2009 (No. 22 of 2009).

The Housing (Standards for Rented Houses) (Amendment) Regulations 2009 made minor amendments to the 2008 Regulations for compatibility with the 2009 Act and completed the new regulatory code. Under the Housing Acts 1966 to 2009, responsibility for the enforcement of the regulations prescribing minimum standards for rented accommodation rests with the relevant housing authority.

Article 13 of the Housing (Standards for Rented Houses) Regulations 2008 (S.I. 534/2008)

Article 13 provides that all electricity and gas installations be maintained in good repair and safe working order. It also provides that there must be, where necessary, provision for the safe and effective removal of fumes to the external air. (See also ventilation). Where an inspector is not satisfied that the installations in the house for the supply of electricity and gas are maintained

correctly, current Periodic Inspection Reports from the Electro-Technical Council of Ireland (ETCI) for electricity installations and compliance with NSAI guidelines for gas installations will prove compliance with the Regulations.

Requirement under article 13 of the Regulations

Installations in the house for the supply of electricity and gas shall be maintained in good repair and safe working order with provision, where necessary, for the safe and effective removal of fumes to the external air.

The following will prove compliance with the Regulations:

1. A current ETCI Periodic Inspection Report by a registered electrical contractor for the electrical installation in the house. The result of the tenancy inspection shall show a standard which requires that “no remedial work is required”.
2. A current Declaration of Conformance for an IS 8133 annex E inspection by a Registered Gas installer for the gas installation in the house.
3. Annex E of the National Standard for Domestic Gas Installation 813 (IS813:2002). This standard is issued by the National Standards Authority of Ireland (NSAI).

The requirement for the ETCI’s inspection report will be on foot of an improvement notice and is issued by the Local Authorities; in the case of Dublin City the relevant authority is Dublin City Council and the appropriate department resides with the Housing & Residential Services, Civic Offices, Wood Quay, and Dublin 8

Re-testing in the United Kingdom

General electrical installations			
Type of Installation	Routine check sub clause 3.5	Maximum period between Inspections	References see notes below.
Domestic	Sellers pack	any change/10 yrs	0.0
Commercial	1 year	any change/5 years	1.2
Educational establishment	4 months	3 years	1.2
Hospitals	1 year	3 years	1.2
Industrial	any change / 1 year	5 years	1.0
Residential accommodation	1 year	5 years	1.2
Offices	1 year	5 years	1.2
Shops	1 year	5 years	1.2
Laboratories	1 year	5 years	1.2

Table 5.2.3 – Routine Check requirement in the United Kingdom

Reference Key:

- Particular attention must be taken to comply with SI 1988 No1057. The electricity supply regulations 1988(as amended)
- The electricity at work regulations 1989 (Regulation 4 & memorandum). SI 1989 No 635
- Code of practice for the emergency lighting of premises other than cinemas and certain specified premises used for entertainment .BS 5266: Part1: 1988
- Other intervals are recommended for testing operations of batteries and generators.
- Code of practice for system design installation and servicing (Fire detection and alarm systems for buildings). BS5839:Part1: 1988
- Local authority conditions of license.
- The cinematograph (Safety) Regulations. SI 1995 No 1129 (Clause 27)

The frequency of re-testing domestic installations in the Republic of Ireland is not specified, however in the United Kingdom, a domestic premises; routine checks are required for the following conditions:

1. On the re-sale of a domestic dwelling – the electrical installation must be inspected, tested and verified, documentation forms part of the Seller's pack.
2. Any change of use – if a domestic dwelling is being converted into apartments
3. At a frequency of 10 years.

5.3 Q3 What is the maximum Disconnection time for a 20A Type B MCB on socket circuit

2010/2011	Class	.4 sec	.2 sec	.5 sec	4 sec	5 sec	Totals
Semester 1	6A & B	43	14	36	4	4	101
Semester 1	6C & D	16	42	29	3	10	100
Semester 2	6A & B	43	57	0	0	0	100
Semester 2	6C	33	13	53	0	0	99
Totals		135	126	118	7	14	400
Percent %		33.75	31.5	29.5	1.75	3.5	

Table 5.3.1 – Response to question No. 3 – Raw data

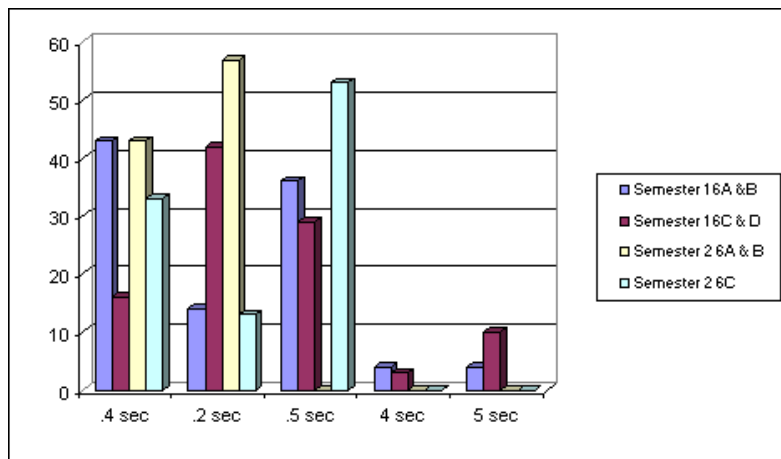

Figure 5.3.1 – Response to question No. 3 – Raw data

Reference to disconnection times can be found in the National Rules for Electrical Installations ET101:2008 see the index on page 342 – Table A61-1 (page 316), Table 41A (page 35), Table A61C – 2 (page 317), Table 41B (page 36), Rule No. 613.4 (page 152) and Annex 61G (page 318) in respect of Residual Current Devices (RCD's).

The correct answer in respect of a 20A B Type MCB on Domestic Socket Circuit the maximum disconnection time is cited at 0.4 seconds if the circuit is operating at 230 volts and this is deemed to be the correct answer. See Table No. 3A which indicated that 33.75% of respondents are correct; this means that 66.25% were incorrect.

Upon closer inspection of Table 41A there are three further factors to be considered as follows:

1. What system of protection is being utilised?
2. The nominal voltage U_0
3. Whether the system is an alternating current or a direct current system (a.c. system or a D.C. system).

The nominal voltage U_0 is a very important factor from an electrical safety perspective –

The nominal voltage is inversely proportional to the disconnection time.

U_0 Volts	Disconnection time (seconds)	
	a.c. systems	d.c. systems
> 50 – 120	0.8	-
> 102 – 230	0.4	5
> 230 – 400	0.2	0.4
> 400	0.1	0.1

Table 5.3.2 – Maximum disconnection times for TN Systems (Source: ET101:2008 page 35)

Examination of Table No. 3B shows an inverse relationship – the lower the value of U_0 the longer the disconnection time. For nominal voltages between 120 volts and 230 volts the disconnection time is 0.4 seconds.

Notice also the disconnection time is 5 seconds for a d. c. system. A close look at the small print see Note 1 and Note 2 see below:

Note 1: For voltages that are within the tolerances stated in EN 50160 the disconnection time appropriate to the nominal voltage applies, e.g. for 230V, the time is 0.4 s.

Note 2: Disconnection may be required for reasons other than protection against electric shock.

Uo Volts	Disconnection time (seconds)	
	a.c. systems	d.c. systems
> 50 – 120	0.3	-
> 102 – 230	0.2	0.4
> 230 – 400	0.07	0.2
> 400	0.04	0.1

Table 5.3.3 – Maximum disconnection times for TT Systems (Source: ET101:2008 page 36)

Examination of Table No. 3B shows an inverse relationship – the lower the value of Uo the longer the disconnection time. For nominal voltages between 120 volts and 230 volts the disconnection time is 0.2 seconds. Notice also the disconnection time is 0.4 seconds for a d. c. system.

A close look at the small print sees Note below:

(Note: For voltages that are within the tolerances specified in I.S. EN 50160, the disconnecting time appropriate to the nominal voltage applies)

For the students question No 3 was more complex then it first appeared; this complexity has lead to encouraging the students to take a holistic view of the national rules and to seek further information without jumping to a quick solution.

The solution which was accepted by 33.75% of respondents would be acceptable if the respondents were Phase 4 students, it would be expected that Phase 6 students might question the selected values much more carefully.

the question in respect of the 0.4 seconds and the 0.2 seconds would involve a deeper understanding of the TN and TT Systems of earthing.

2010/2011	Class	.4 sec	.2 sec	.5 sec	4 sec	5 sec	Totals
Semester 1	6A & B	13	4	12	1	1	31
Semester 1	6C & D	5	13	9	1	3	31
Semester 2	6A & B	14	18	0	0	0	32
Semester 2	6C	5	2	9	0	0	16
Totals		37	37	30	2	4	110
Percent %		33.64	33.64	27.27	1.82	3.64	

Table 5.3.4 – Response to question No. 3 – Cleaned data

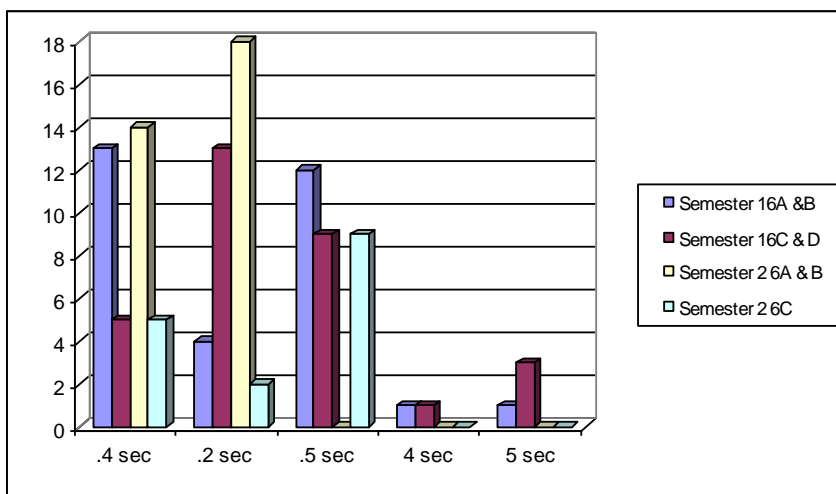

Figure 5.3.2 – Response to question No. 3 – Cleaned data

5.4 Q.4 when checking a 20A C Type MCB on a domestic socket circuit what is the maximum value of fault loop impedance

2010/2011	Class	1.5 Ω	0.5 Ω	0.05 Ω	5 Ω	None	
Semester 1	6A & 6B	43%	14%	36%	4%	4%	101%
Semester 1	6C & 6D	45%	32%	13%	6%	3%	99%
Semester 2	6A & 6B	7%	57%	36%	0%	0%	100%
Semester 2	6C	3%	79%	14%	3%	6%	105%
Totals		98%	182%	99%	13%	13%	405%
Percent %		24.20%	44.94%	24.44%	3.21%	3.21%	

Table 5.4.1 – Responses to question No. 4 – Raw data

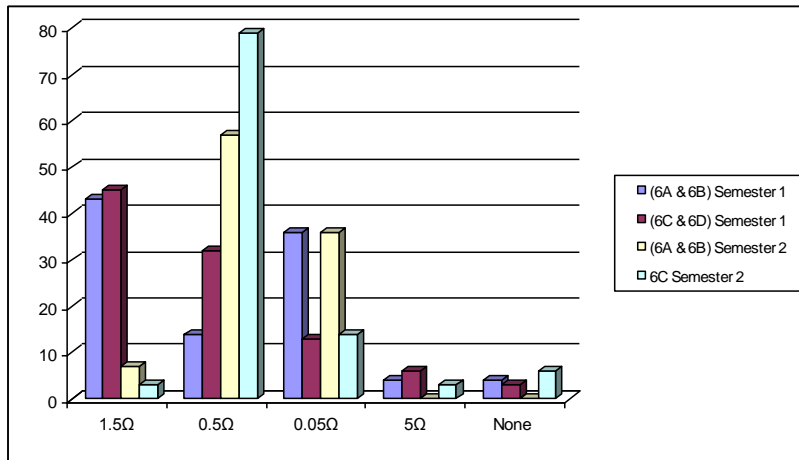

Figure 5.4.1 – Responses to question No. 4 – Raw data

The methodology used in the analysis of the data; relates to the earth fault impedance path – this is the earth fault path that an earth fault current would take in the event of a low or a high impedance earth fault current. Four values were presented to the participants. The participants were required to use basic understanding to predict the correct response.

112 respondents were queried using the Turner Pointing Clickers response device system over a full academic year spanning two semesters – this enabled the respondents to answer the questions in a controlled anonymous basis on a non-intimidating environment.

The Turner Pointing Clickers system allows immediate proactive feedback from students indicating that the subject matter was not comprehended. This facilitated an interactive discussion within the various groups thus enabling the subject matter to be comprehensively explored leading to deep seated learning being achieved and a reversal of the misconception occurred.

The responses to the question indicated that 3.21% of the participants correctly answered the question while 96.79% were incorrect.

A further analysis of the raw data was carried out converting the percentages given in Table No 4 to actual student numbers see Table No. 5.

Question 4 Statistical Analysis								
2010/2011	Class	1.5 Ω	0.5 Ω	0.05 Ω	5 Ω	None	Totals	
Semester 1	6A & 6B	14	4	12	1	1	32	
Semester 1	6C & 6D	14	10	4	5	1	*34	
Semester 2	6A & 6B	2	18	12	0	0	32	
Semester 2	6C	0	13	2	0	2	*17	
Students		31	46	29	7	4	*117	
Percent %		26.50	39.32	24.79	5.98	3.42	100.00	
		*7 class groups = (16 x 7) = 112						

N = 112 – 3.42% answered correctly; 96.58% answered incorrectly - *rounding normally 16 students per class group

Table 5.4.2 – Responses to question No. 4 – Cleansed data

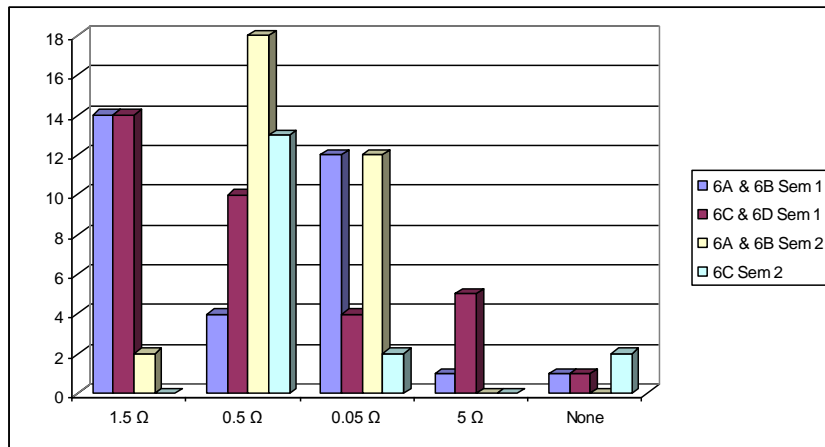

Figure 5.4.2 – Responses to question No. 4 – Cleansed data

A further examination of the National Rules for Electrical Installations – ET101:2008 4th Edition clearly shows the correct solution is 0.77 Ω since this value is not given in the selected values, the solution “None” is correct. See page 317 of the National Rules for Electrical Installations – ET101:2008 4th Edition

MCB Type C (I.S.EN 60898 and RCBO Type C: (I.S.EN 61009) Motors, lighting systems						
Rating A:	6	10	16	20	25	32
Z_L Ω	2.5	1.6	0.9	0.77	0.51	0.5

Table 5.4.3 – Correct solution to question No. 4 (Source: ET101:2008 page 35)

The responses to the question indicated that 3.42% of the participants correctly answered the question while 96.58% were incorrect.

It is important to view the data as a general trend rather than an accurate statistical result.

5.5 Q5 What is the maximum Disconnecting of a 30 milli ampere RCD

Residual Current Devices (RCD's – Operating Times

RCDs fall into two categories in terms of the time taken to respond to and clear residual currents, as follows:

i) **General Type** These RCDs have no specified minimum response time but have specified maximum response times as follows.

$$I_{\Delta n} < 300\text{mS}$$

$$5 I_{\Delta n} < 40\text{mS}$$

ii) **S Type** These RCDs, commonly known as delayed types, have specified minimum and maximum response times, as follows.

$$I_{\Delta n} \geq 130 - 500\text{mS}$$

$$5 I_{\Delta n} \geq 50 - 150\text{mS}$$

Delayed response (S Type) RCDs are commonly fitted upstream of General Type RCDs, but General Type RCDs should never be fitted upstream of Delayed types. (See 5.1.4 Discrimination).

The term “**upstream**” refers to proximity to the origin of the installation and “**downstream**” refers to proximity to the load.

Sensitivity:

This is commonly called the operation or tripping current of the device and it is the value of leakage current at which the RCD will operate. The choice of sensitivity depends on the application and must be chosen in compliance with the ETCI Rules (section 531 page 100 ET101:2008 – 4th Edition)

Sensitivity levels ($I_{\Delta n}$) in compliance with IEC 1008 are: 10, 30, 100, 300, and 500mA.

See details contain in 2.1.6 Residual Current Devices (RCDs) – Introduction (Review of Literature)

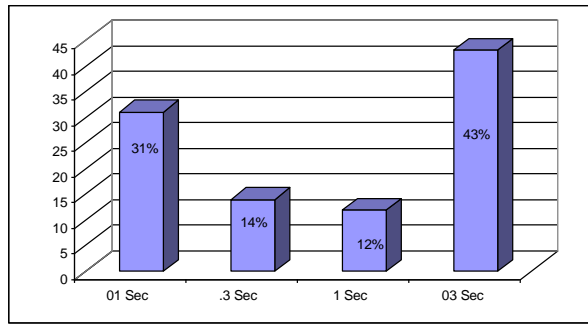

Figure 5.5.1 – Responses to question No. 5 – Raw data

The results are illustrated in Figure 5.5.1 the results are unexpected as question five was non-specific in terms of what type of residual current device is used; there are five types of residual current device in common use.

The five common RCD's in general use have an $I_{\Delta n}$ as follows:

1. 10 mA – ordinary type RCD
2. 30mA – general type RCD
3. 100 mA
4. 300 mA } special type RCD's
5. 500 mA

Since only one of the above categories is applicable this is the **General Type** These RCDs have no specified minimum response time but have specified maximum response times as follows.

$$I_{\Delta n} < 300\text{mS}$$

$$5 I_{\Delta n} < 40\text{mS}$$

This implies that the general type RCD has a maximum response time of $I_{\Delta n} < 300\text{mS}$

14% of respondents were correct whilst 86% were incorrect.

5.6 Q 6 what are the two main post-connection tests for an installation

2010/2011	Class	*1	*2	*3	*4
Semester 1	6A & B	32	14	43	11
Semester 1	6C & D	42	10	45	3
Semester 2	6A & B	20	40	40	0
Semester 2	6C	43	13	40	3
Totals		137	77	168	17
Percent %		34.34	19.30	42.11	4.26

Table 5.6.1 – Response to question No. 6 – Raw data

Legend to Table No. 6A:

*1	Earth Fault Loop Impedance & RCD trip time
*2	RCD trip time & Insulation test
*3	Earth Fault Loop Impedance & Polarity
*4	Insulation Test

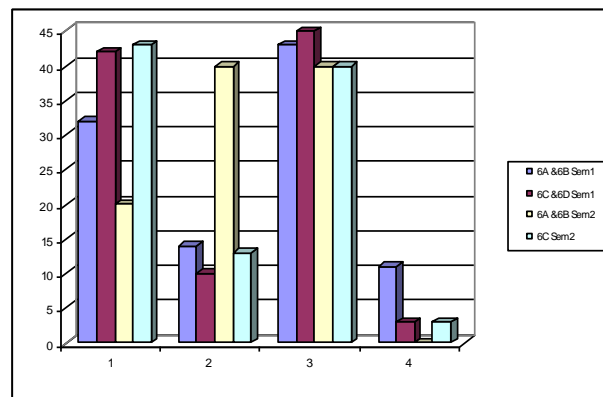

Figure 5.6.1 – Response to question No. 6 – Raw data

The National Rules for Electrical Installations – ET101:2008 4th Edition the criteria relating to testing of an electrical installation is very clear, this is catered for in Part 6 of ET 101:2008.

Part 6 is divided into three chapters as follows:

6. Chapter 61: Initial Verification
7. Chapter 62: Periodic Inspection and Testing
8. Chapter 63 :Certification

Testing of electrical installations is specified in Part 6 of the national Rules for Electrical Installations – ET101:2008 – 4th Edition (see page 151)

The general approach to testing is to divide the tests into two specific groups;

1. pre-connection tests
2. post-connection tests

The test methods specified in this chapter 61 are reference methods. Other methods are not precluded provided they give no less valid results.

Pre-connection tests: i.e. before the installation is energised

The following tests shall be carried out where applicable and preferably in the following sequence:

a) Before the installation is energised:

- Continuity of protective and bonding conductors (613.2.1),
- Continuity of all conductors of final ring circuits (613.2.2),
- Insulation resistance of the electrical installation (613.3),
- Detection of erroneous connections between circuits (613.4),
- Separation of circuits: SELV, PELV, electrical separation (613.5),
- Conditions for protection (automatic disconnection of supply), earthing & equipotential bonding, (613.6),
- Floor and wall resistance (613.7),
- Polarity (613.8), - phase sequence (613.9),
- Voltage drop (where desired) (613.10),
- Electric strength tests for assemblies built or modified on site (613.11),
- Functional tests (613.12).

Post-connection tests after the installation is energised

b) After the installation is energised:

- Fault-loop impedance measurement (613.13),
- Verification of operation of RCDs (613.14).

Should the installation fail a test, that test and any preceding tests that might have been influenced by the fault indicated, shall be repeated after the fault has been rectified The correct solution – Earth Fault Loop Impedance & RCD trip time

From an electrical safety perspective verification and testing of an electrical installation is crucial to the safety of an installation. Stringent regulation is required in this respect.

Fault Loop Impedance measurement is required in respect of every part of the electrical installation; actual measurement is required. Since the earth fault loop can vary greatly the regulations give detailed guidance.

The measurement of earth-fault loop impedance of circuits is given in Annex 61F

The fault loop impedance should be measured using a proprietary instrument having a facility for measuring low values of impedance.

In TN systems, the main protective conductor (“neutralizing link”) must be left in place.

Measurements are made as follows:

- a) At the location of the main fuse, the instrument is connected between the phase conductor and the main earthing terminal.
- b) For a final circuit, the instrument is connected at the furthest point of the circuit between the phase conductor and the corresponding point on the associated protective conductor, e.g. at a socket outlet.

Selecting the appropriate overcurrent device depends on the value of the fault loop impedance.

Table 61C-1 gives the maximum values of fault loop impedance for a range of fuses and MCBs for all circuits of rating up to 32A inclusive (0.4 s disconnection time)

Table 61C-2 gives the maximum values of fault loop impedance for circuits of rating exceeding 32A (5 seconds disconnection time).

The values given in the tables are those for a nominal voltage to earth of 230V a.c. r.m.s.

For any other voltage V , the values should be multiplied by the factor $V/230$

For other types of fuse or MCB, the values of fusing or tripping current I_f may be obtained from the characteristic curves for the times of 0.4 sec or 5 sec as appropriate. The characteristic curves for fuses and MCBs are available from all reputable manufacturers.

The maximum fault loop impedance Z_L corresponding to the tripping current I_f is obtained from the formula:

$$Z_L = \frac{230}{I_f} \times 0.67 \Omega$$

0.67- is a factor that takes account of the rise in temperature and resistance when the measurement is made when no current has been flowing. Annex 61G – Verification of Operation of RCDs (page 318)

For compliance with 613.14, the operating characteristics of an RCD should be verified by injecting a test residual current and recording the time of operation by means of a proprietary instrument specifically designed for the purpose. The values obtained should be in accordance with the tables below. Alternatively, any point on the characteristic curve may be verified, but the value obtained must be compatible with those in the tables.

Standard Values of Operating Time for RCDs – GENERAL TYPE

Test current	$I_{\Delta n}$	$2I_{\Delta n}$	$5I_{\Delta n}$
Maximum operating times:	0.03s	0.15s	0.04s

Table 5.6.2 – Type G Residual Current Device (Source ET101:2008 page 31)

Test current	$I_{\Delta n}$	$2I_{\Delta n}$	$5I_{\Delta n}$
Maximum operating times:	0.5s	0.2s	0.15s
Minimum non-actuating times	0.13s	0.06s	0.05s

Standard Values of Operating Time for RCDs – SPECIAL TYPE S

Table 5.6.3 – Type S Residual Current Device (Source ET101:2008 page 318)

$I_{\Delta n}$ is the rated residual operating current e.g. 30mA or 300mA.

*For RCDs rated 30mA or less, 0.25A may be used instead of 5 $I_{\Delta n}$

The load should be disconnected during testing in order to interrupt the normal earth leakage currents from equipment. Disconnection should be made at the permanent terminations. Insulated connectors should be used for injecting current.

Residual Current Devices (RCD's) are electro-mechanical devices which are crucial for electrical safety in terms of electric shock hazards and fire hazards. The Electro-Technical Council of Ireland (ETCI) has published a detailed study of RCD' and this can be down-loaded free of charge from the ETCI's website.

This Guide is intended to provide specifiers, installers and users who have better understanding of the application, selection and use of such products.

This publication is intended for use as a guide only, and has no regulatory or statutory status and should therefore be used in conjunction with the current issue of the National Rules for Electrical Installations (ET101), relevant product standards, and I.S. EN60439 – Low Voltage Switchgear and Control Gear Assemblies, where applicable. T

The Guide is limited to RCDs intended for domestic and similar use, having a rated voltage not exceeding 400V AC and a rated current not exceeding 125A.

Table 5.6.4 – Response to question No. 6 – Cleansed data

2010/2011	Class	*1	*2	*3	*4	Totals
Semester 1	6A &B	10	4	14	4	32
Semester 1	6C & D	13	4	14	1	32
Semester 2	6A & B	6	13	13	0	32
Semester 2	6C	7	2	6	0	16
Totals		37	23	47	5	112
Percent %		32.95	20.40	42.23	4.42	100

Legend to Table No. 6B:

*1	Earth Fault Loop Impedance & RCD trip time
*2	RCD trip time & Insulation test
*3	Earth Fault Loop Impedance & Polarity
*4	Insulation Test

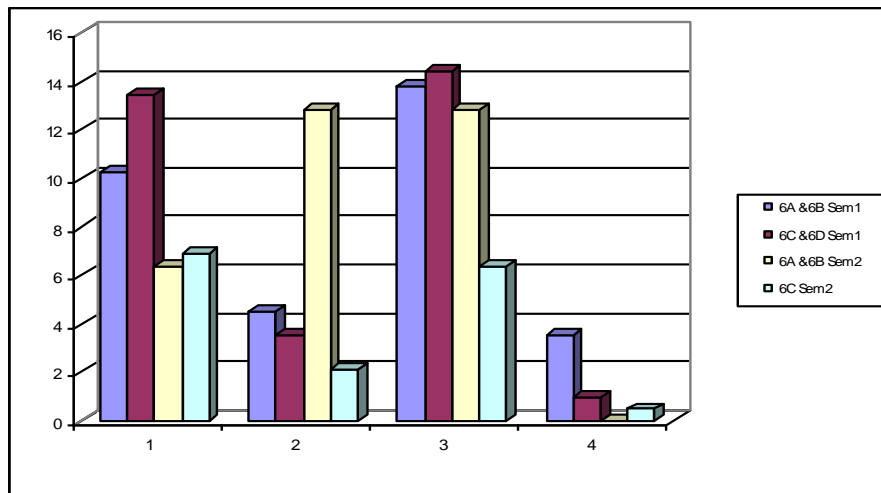

Figure 5.6.2 – Response to question No. 6 – Cleaned data

5.7 Q 7 According to the ETCI why are Wiring Rules so strict for bathrooms

2010/2011	Class	*1	*2	*3	*4
Sem 1	6A &B	7	71	14	7
Sem 1	6C & D	13	83	0	3
Sem 2	6A & B	7	67	13	13
Sem 2	6C	10	83	7	0
Totals		37	304	34	23
Percent %		9.30	76.38	8.54	5.78

Table 5.7.1 – Response to question No. 7 – Raw data

Legend to Table No. 7A:

*1	Nearly every year someone is electrocuted in a bathroom because of breaches in the wiring RCD trip time & Insulation test
*2	It is classified as a zone 4 protection area
*3	Higher Insulation requirements
*4	None of above

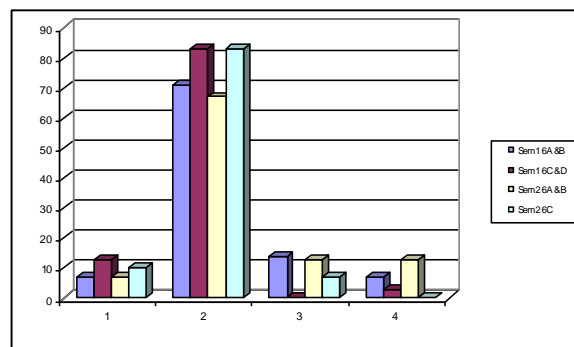

Figure 5.7.2 – Response to question No. 7 – Raw data

The National Rules for Electrical Installations ET101:2008 4th Edition the criteria relating to testing of an electrical installation in a bathroom is catered for in locations containing a bath or a shower – Section 701 page 164 of ET 101:2008.

Location containing a bath or shower basin – 701

The particular requirements of this section apply to the electrical installations in locations containing a fixed bath or shower and to the surrounding zones as described in this section. This section does not apply to emergency facilities, e.g. emergency showers used in industrial areas or laboratories.

Note 1: For locations containing a bath or a shower unit for medical treatment, or for disabled persons, special requirements may be necessary.

Note 2: For prefabricated bath or shower units see EN 60335-2-105

Classification of Zones – 701.30

701.30.01 The zones specified below shall be taken into account. For fixed prefabricated bath or shower units, the zones are applied to the situation where the bath or shower unit is in its usable configuration. Horizontal or inclined ceilings, walls with or without windows, doors, floors and fixed partitions may limit the extent of rooms containing a bath or shower as well as the zones. Where the dimensions of fixed partitions are smaller than the dimensions of the relevant zones, e.g. partitions having a height lower than 2.25m, the minimum distances in the horizontal and vertical directions shall be taken into account.

For electrical equipment in parts of walls or ceilings limiting the zones specified, but being part of the wall surface of that wall or ceiling, the requirements of the respective zones apply. A cupboard or closet opening directly into a location containing a bath or shower-basin shall be deemed to form part of the appropriate zone or zones for the purposes of this section.

701.30.02-- Zone 0 is the interior of the bath or shower- basin.

In a location containing a shower- unit without a basin, Zone 0 is limited by:

- The floor and the plane 100 mm above the finished floor level, and
- The vertical plane at a radius of 600 mm, measured horizontally, from the fixed water outlet at the wall or overhead.
-

701.30.03 --Zone 1 is limited by:

- The upper plane of Zone 0, and

- The horizontal plane 2.25 m above the finished floor level of the bathroom, and the vertical plane circumscribing the bath.

In a location containing a shower unit, Zone 1 is limited by:

- The horizontal plane corresponding to the highest fixed shower- head or water-outlet, whichever is higher, and
- The vertical plane circumscribing the shower base, or
- For a shower without a basin, with a demountable head, the vertical plane at a radius of 1200mm, measured horizontally, from the water outlet on the wall, or for a shower without a basin and with a fixed head, the vertical plane at a radius of 600 mm measured horizontally, from the shower- head.
- Zone 1 includes the space below the bath or shower basin if the space is accessible without a tool.

701.30.04 --Zone 2 is limited by:

- the vertical plane(s) external to Zone 1 and the parallel vertical plane at a distance of 600 mm, measured horizontally, from Zone 1, and
- for a bath, the finished floor level and the horizontal plane 2.25 m above the finished floor level, or
- for a shower, the horizontal plane 2.25 m above the finished floor level or the horizontal plane corresponding to the highest fixed shower- head or water outlet, whichever is higher.

701.30.05 --Zone 3 is limited by:

- The vertical plane(s) external to Zone 2 and the parallel vertical plane(s) 2.40 m, measured horizontally, from Zone 2, and
- The floor and the horizontal plane 2.25 m above the finished floor level. In addition, where the ceiling height exceeds 2.25 m above the finished floor level, the space above Zones 1 and 2 up to the ceiling or to a height of 3.0 m above the finished floor level, whichever is lower, is in Zone 3.
- Zone 3 also includes the space below the bath or shower basin if it is accessible only by means of a key or tool.

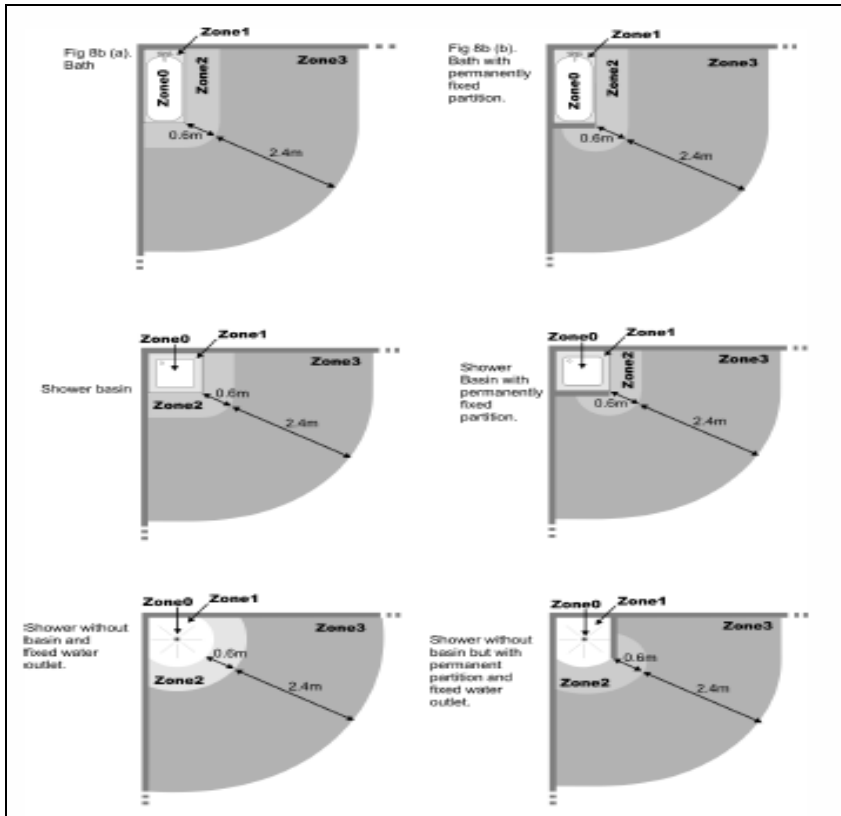

Figure 5.7.3 – Example of Zone Dimensions –Plan view (Source ET101 :2008 – page 171)

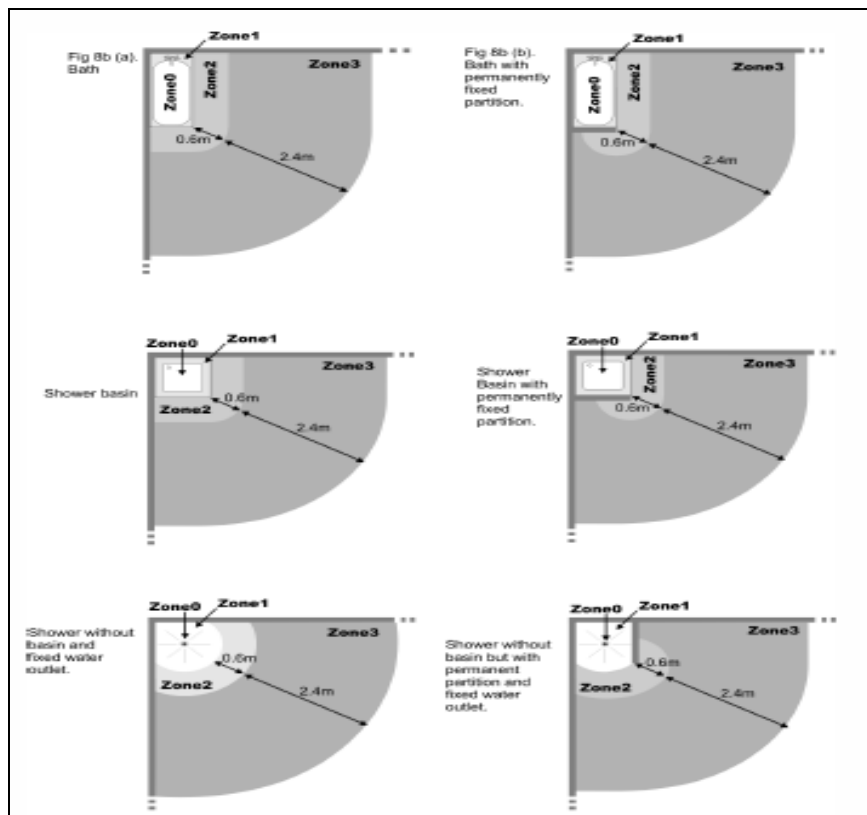

Figure 5.7.4 – Examples of Zone Dimensions – Elevation view

(Source ET101 :2008 – page 172+)

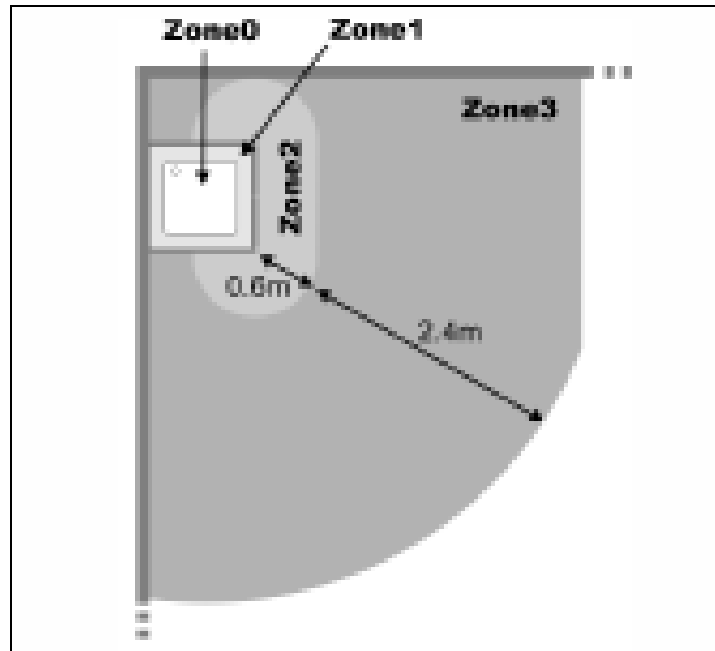

Figure 5.7.5 – Prefabricated Shower Unit (Source ET101:2008 – page 173)

Electrical Equipment permissible in rooms containing a bath or shower

Zone	Switchgear and accessories	Fixed Appliances etc.
0	None	IPX7 Appliances to EN suitable for use in Zone 0 Appliances for SELV 12V a.c.
1	Switches and accessories up to SELV 25V a.c. max. Wall-outlet boxes for Zone 1 appliances	IPX4 As in Zone 0, and in addition: Appliances to EN suitable for Zone 1 e.g. water heaters Appliances for SELV 25V a.c.
2	As in Zone 1, and in addition: Shaver outlets Switches and accessories up to SELV 25V a.c. Accessories for signalling and control equipment for SELV. Wall-outlet boxes for Zone 2 Appliances.	IPX4 As in Zone 2, and in addition: Appliances to EN suitable for Zone 2 Luminaires in accordance with (701 :559).
3	As in Zone 2, and in addition: Accessories and equipment in Zone 3 Wall-outlets for appliances in Zone 3 Socket-outlets at SELV only Wall-switches at SELV only Cord-operated switches at 2.25 m only	No special requirements except for luminaires (701 :559).

Table 5.7.2 – Electrical Equipment permissible in rooms containing a bath or shower (Source ET101:2008 – page 173)

Table 5.7.3 – Response to question No. 7 – Cleansed data

2010/2011	Class	*1	*2	*3	*4
Sem 1	6A & B	2	24	4	2
Sem 1	6C & D	4	27	0	1
Sem 2	6A & B	2	22	4	4
Sem 2	6C	2	14	0	0
Totals		10	87	8	7
Percent %		8.93	77.68	7.14	6.25

Legend to Table No. 7C:

*1	Nearly every year someone is electrocuted in a bathroom because of breaches in the wiring RCD trip time & Insulation test
*2	It is classified as a zone 4 protection area
*3	Higher Insulation requirements
*4	None of above

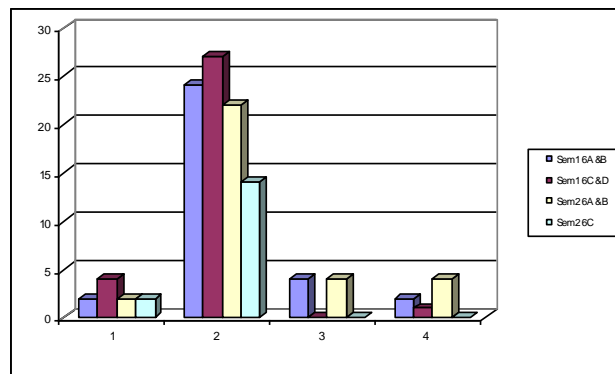

Figure 5.7.6 – Response to question No. 7 – Cleansed data

77.68% of respondents answered correctly while 22.32% were incorrect; most respondents were confused with the fact that bathrooms are classified into 4 Zones – the confusion arose by the fact that an examination of Figures 7B, 7C and 7D clearly shows the following zones:

1. Zone 0
2. Zone 1
3. Zone 2
4. Zone 3

The students queried Zone 0 – Zone 0 is the interior of the bath or shower- basin.

In a location containing a shower- unit without a basin, Zone 0 is limited by:

- The floor and the plane 100 mm above the finished floor level, and
- The vertical plane at a radius of 600 mm, measured horizontally, from the fixed water outlet at the wall or overhead.

Additional safety precautions in Zone 2:

- Protection by #SELV, the safety source being installed outside Zones 0, 1 and 2; or
- Protection by automatic disconnection of supply by means of an RCD with a rated residual operating current not exceeding 30mA in accordance with 416.1

SELV – Safety extra low voltage

A voltage not exceeding 50 V a.c. or 120 V d.c. between conductors at any point of a circuit which is separated from circuits with higher voltages and from earth by insulation at least equivalent to that for Class II or which has equivalent protective means.

5.8 Q 8 According to the ETCI why does the Wiring Rules place so much importance on the location of the Distribution Board

Table 5.8.1 – Response to question No. 7 – Raw data

2010/2011	Class	1	2	3	4
Sem 1	6A & B	17	24	59	0
Sem 1	6C & D	7	17	70	7
Sem 2	6A & B	7	0	93	0
Sem 2	6C	14	7	68	11
Totals		46	50	293	22
Percent %		11.19	12.17	71.29	5.35

Legend to Table No. 8A:

1	Closest to entrance and exit point
2	For identification of tripped circuits
3	It must be readily accessible at all times and it must properly ventilated
4	None of the above

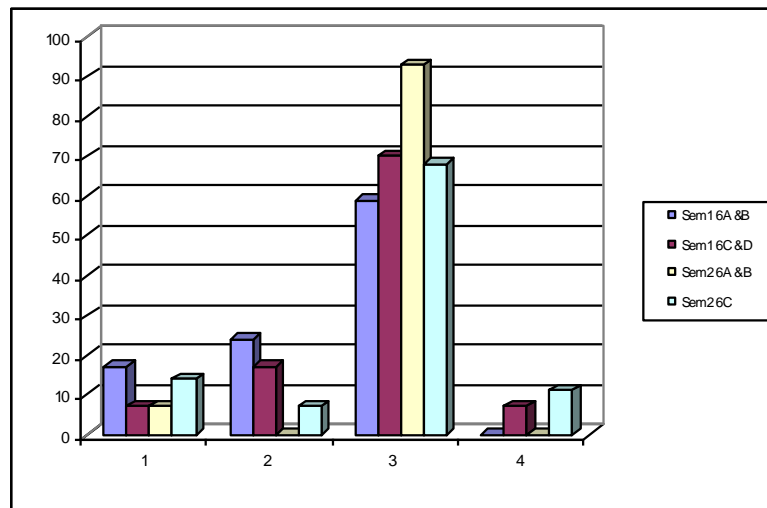

Figure 5.8.1 – Response to question No. 8 – Raw data

The National Rules for Electrical Installations ET101:2008 4th Edition the criteria relating to distribution boards in an electrical installation the definition of a distribution board is located on page 12 of ET 101:2008.

Distribution Board: An assembly of protective devices, including two or more fuses or circuit breakers, arranged for the distribution of electrical energy to final circuits or to other distribution boards.

To the non-electrical fraternity distribution boards are also known as fuse boards, since the distribution board or fuse board contains the protective devices and is effectively the centre of the electrical installation, acting as a hub which permits the distribution cable feeding the electrical installation to be connected to all other circuits; in addition to protective devices the distribution board or fuse board contains a means of electrical safety isolation.

In older housing stock pre 1980's fuse boards were in common use, see Figure 5.8.2 the typical fuse board contained an electrical isolator (main switch) and a series of fuses. Residual Current Devices (RCD's) were not generally installed.

Figure 5.8.2 also depicts the arrangement for the DSO distribution cable connected to the service cut-out containing a 80 ampere HRC fuse and the metering arrangement.

The fuse board consists of an electrical isolator, a 63 ampere DZ fuse and a selection of sub-circuit fuses; note the fuse board does not contain a Residual Current Device (RCD).



Figure 5.8.2 – Diagram of a fuse board in a domestic dwelling

Figure 5.8.3 illustrates a distribution board (also known as consumer units), this is the modern equivalent of a fuse board with fuses being replaced by miniature circuit breakers (MCB's) the unit contained an electrical isolator which incorporates an neozed fuse which provides back-up protection. The inclusion of a Residual Current Device (RCD) is now mandatory in all domestic electrical installations in the Republic of Ireland.



Figure 5.8.3 – Diagram of a distribution board in a domestic dwelling

Electro-Technical Council of Ireland (ETCI) requirements are summarised below in respect of the location of distribution boards or more importantly where it is prohibited to locate a distribution board – this information can be viewed on page 99 of ET101:2008.

Rule number 530.5 Erection of distribution boards

530.5.1 A distribution board shall be adequately protected against adverse environmental conditions such as dust, moisture, corrosive or polluting substances, excessive temperatures, impact, vibration and other mechanical stresses.

530.5.2 A distribution board shall be suitably located or protected so as to avoid possible damage arising from a fault in another service or in the course of maintenance. This may be achieved by supplementary measures such as barriers or separation.

530.5.3 A distribution board shall be located in a location where it is readily accessible. A wall-mounting distribution board shall be mounted at a height not exceeding 2.25 m measured from the floor to the top surface of the board or 1.4 m measured from the floor to the bottom of the board. A distribution board located in a switch-room shall in addition comply with 539.

530.5.4 A distribution board shall not be installed in the following locations:

- Storage or airing cupboards,
- Under timber staircases,
- Where it may be covered by garments or similar articles.
- In a bathroom, washroom or WC.

A distribution board shall not be mounted over a cooking or heating appliance.

A distribution board installed in areas of increased fire hazard shall in addition comply with 422.2.1

530.5.5 A distribution board shall not be located in an escape route such as a stairway or corridor, unless supplementary fire protective measures are provided. This requirement does not apply to single occupancy buildings and similar premises outside the scope of the fire authority's requirements.

530.5.6 A distribution board shall not be located within 400 mm in any direction from a gas meter or a gas appliance. This shall not apply where the gas meter is located within a separate gas-tight enclosure.

Distribution board safety campaign – Push the button – on the hour!

Pushing a button this weekend could save a life. Householders and businesses have been asked to use the occasion of the switch to winter time to carry out a simple safety test. The ETCI strongly urges householders and workplaces to regularly check that their Residual Current Devices (RCDs) are working correctly. ETCI recommends that RCDs are checked at least twice yearly. An ideal time to do this is at the spring and autumnal equinox time change, e.g. when the clocks change to winter time this weekend. RCDs, also known as earth leakage circuit breakers or safety switches, are essential for electrical safety and can prevent electrocution.

They can be found on the electrical distribution boards in houses and workplaces. The design of RCDs means they immediately switch electricity off when electricity “leaking” to earth is detected at a level harmful to a person using electrical equipment. Regularly checking RCDs using the test button provided is essential to ensuring they are working correctly. The warning is issued in time with the changing of the clocks. The message is clear: “For your sake as well as family members and fellow workers use the changing clocks back an hour as a reminder to check your RCD”.

How to test an RCD can be viewed on the ETCI website the purpose and operation of RCD shown on a video clip [“RCDs Saving Lives”](#)

The: ETCI strongly urges householders and workplaces to regularly check that their Residual Current Devices (RCDs) are working correctly. ETCI recommends that RCDs are checked at least twice yearly. An ideal time to do this is at the spring and autumnal equinox time change.

RCD’s, also known as earth leakage circuit breakers or safety switches, are essential for electrical safety and can prevent electrocution. They can be found on the electrical distribution boards in houses and workplaces.

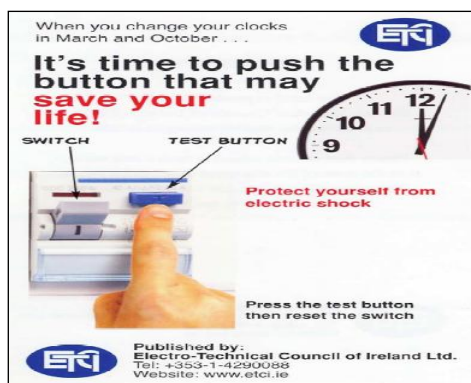

5.8.4-RCD Test Sticker on Your Distribution Board

The design of RCDs means they immediately switch electricity off when electricity “leaking” to earth is detected at a level harmful to a person using electrical equipment. Regularly checking RCD’s using the test button provided is essential to ensuring they are working correctly.

The correct solution to the question is that the distribution board must be readily accessible at all times and it must properly ventilated – 70.49% of respondents were correct while 29.51% were incorrect

Table 5.8.2 – Response to question No. 8 – Cleansed data

2010/2011	Class	1	2	3	4	Totals
Sem 1	6A & B	5	8	19	0	32
Sem 1	6C & D	2	5	23	2	32
Sem 2	6A & B	2	0	30	0	32
Sem 2	6C	2	1	11	2	16
Totals		12	16	86	8	122
Percent %		9.84	13.11	70.49	6.56	100

Legend to Table No. 8B:

1	Closest to entrance and exit point
2	For identification of tripped circuits
3	It must be readily accessible at all times and it must properly ventilated
4	None of the above

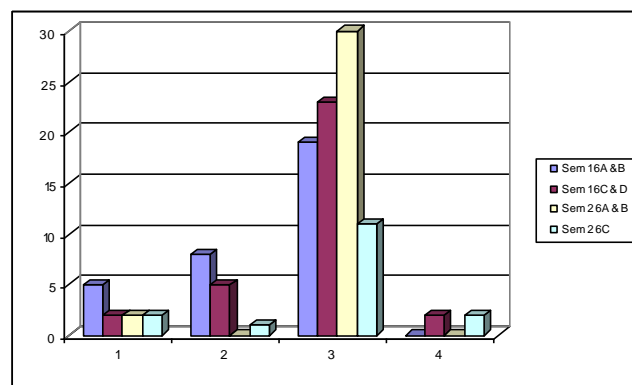

Figure 5.8.5 – Response to question No. 8 – Cleansed data

5.9 Q 9 What is a TN-C System of protection

Table 5.9.1 – Response to question No. 9 – Raw data

2010/2011	Class	1	2	3	4	Totals
Sem 1	6A & B	29	39	18	14	100
Sem 1	6C & D	23	57	13	7	100
Sem 2	6A & B	33	53	7	7	100
Sem 2	6C	21	50	25	4	100
Totals		106	199	63	32	400
Percent %		26.5	49.75	15.75	8	100

Legend to Table No. 5.9.1:

1	Terra Neutral Conductive path
2	Neutral & Protective conductors combined
3	Terra Neutral Conductor
4	Terra Neutral Circuit

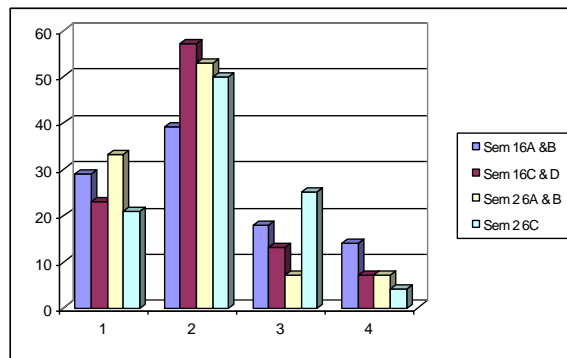

Figure 5.9.1 – Response to question No. 9 – Raw data

The National Rules for Electrical Installations ET101:2008 4th Edition the criteria relating to the TN – C are located on page 28 of ET 101:2008.

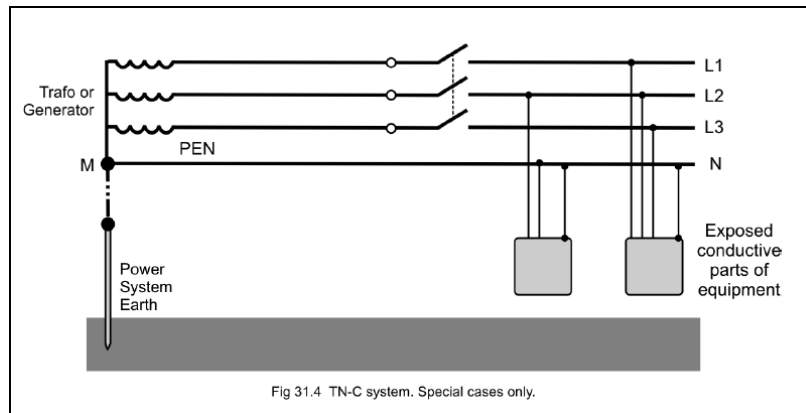

Figure 5.9.2 – TN-C system of earthing

(ETCI) – see page 22 of ET101:2008 --312.2 Types of system earthing

The types of system earthing listed below are recognised for the purposes of these Rules:

The code used is as follows:

First letter: Relationship of the supply system to earth

T = Direct connection of one point to earth.

I = All live parts isolated from earth, or one point connected to earth through an impedance.

Second letter: Relationship of the exposed conductive parts of the installation to earth.

T = Direct electrical connection of exposed conductive parts of the installation to earth, independently of the earthing of any point of the supply system;

N = Direct electrical connection of the exposed conductive parts to the earthed conductor of the supply system. In a.c. systems, the earthed conductor is normally the neutral conductor;

Third letter: Relationship of the neutral conductor to the protective conductor.

S = Separate neutral and protective conductors;

C = Neutral and protective functions combined in a single conductor (PEN)

312.2.1 TN systems (neutral connected to earth)

In TN power systems, one pole, usually the neutral, is directly earthed at the origin. The exposed conductive parts of the installation are connected to that pole by a protective conductor (e.g. the main protective conductor). Three types of TN earthing system are recognised, according to the arrangement of neutral and protective conductors as follows:

- a) TN-C-S: Neutral and protective conductor functions are combined in a single conductor in part of the system. (Figures 31. 1 and 31.2).
- b) TN-S: Separate neutral and protective conductors run throughout the system (Figure 31.3).
- c) TN-C: Neutral and protective conductors' functions are combined in a single conductor throughout the system. (The TN-C system is not normally used in installations in Ireland). (Figure .3.1.4).

Where the installation is supplied from more than one source, account shall be taken of operating currents that may flow through unintended paths and which might cause fire, corrosion or electromagnetic interference.

The most common earthing system used in the Republic of Ireland is the TN-C-S earthing system.

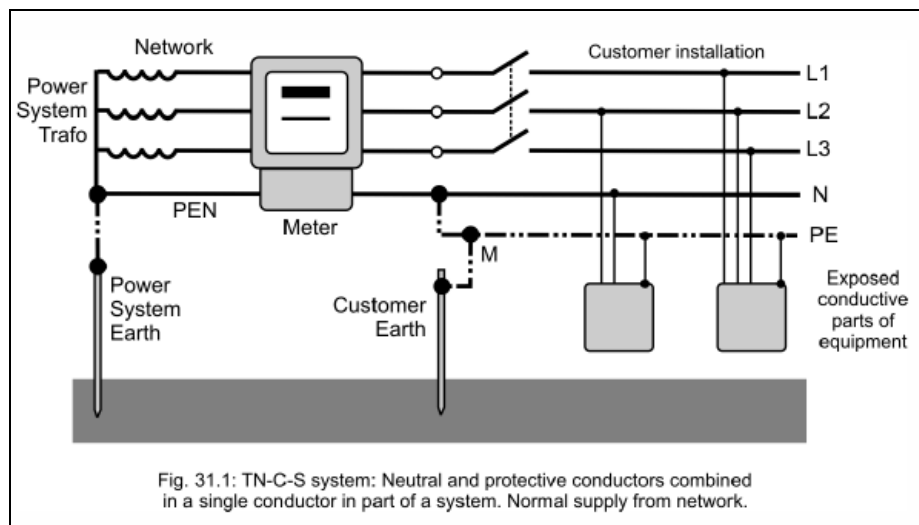

Figure 5.9.3 – TN-C-S system of earthing

Note the subtle difference between Figure 5.9.2 and Figure 5.9.3 – In Figure 5.9.2 there is only one earth electrode on the supply-side of the network; in Figure 5.9.3 an additional earth electrode is provided on the consumer's side of the network and in addition the electrical supply is neutralised – this has major significance in respect of electrical safety.

The earthing system is combined in the form of a PEN (protective earth and neutral) conductor for part of the electrical installation and the protective earthing conductor and the neutral conductor are separate in the most of the electrical installation.

A characteristic of the system is that the system is neutralised [the neutral and the earthing terminal (M) are electrically connected together]

The correct solution to the question is 49.11% of respondents were correct while 50.89% were incorrect

Table 5.9.2 – Response to question No. 9 – Cleansed data

2010/2011	Class	1	2	3	4	Totals
Sem 1	6A &B	9	12	7	4	32
Sem 1	6C & D	7	18	5	2	32
Sem 2	6A & B	11	17	2	2	32
Sem 2	6C	3	8	4	1	16
Totals		30	55	18	9	112
Percent %		26.79	49.11	16.07	8.04	100

Legend to Table No. 9B:

1	Terra Neutral Conductive path
2	Neutral & Protective conductors combined
3	Terra Neutral Conductor
4	Terra Neutral Circuit

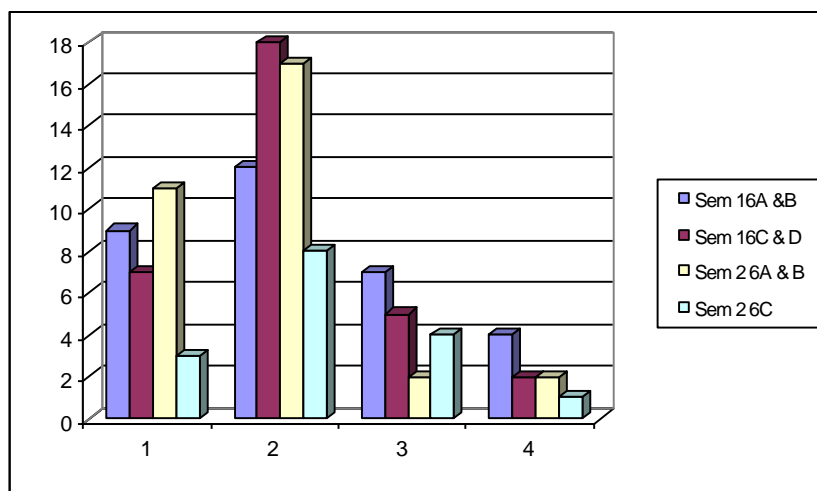
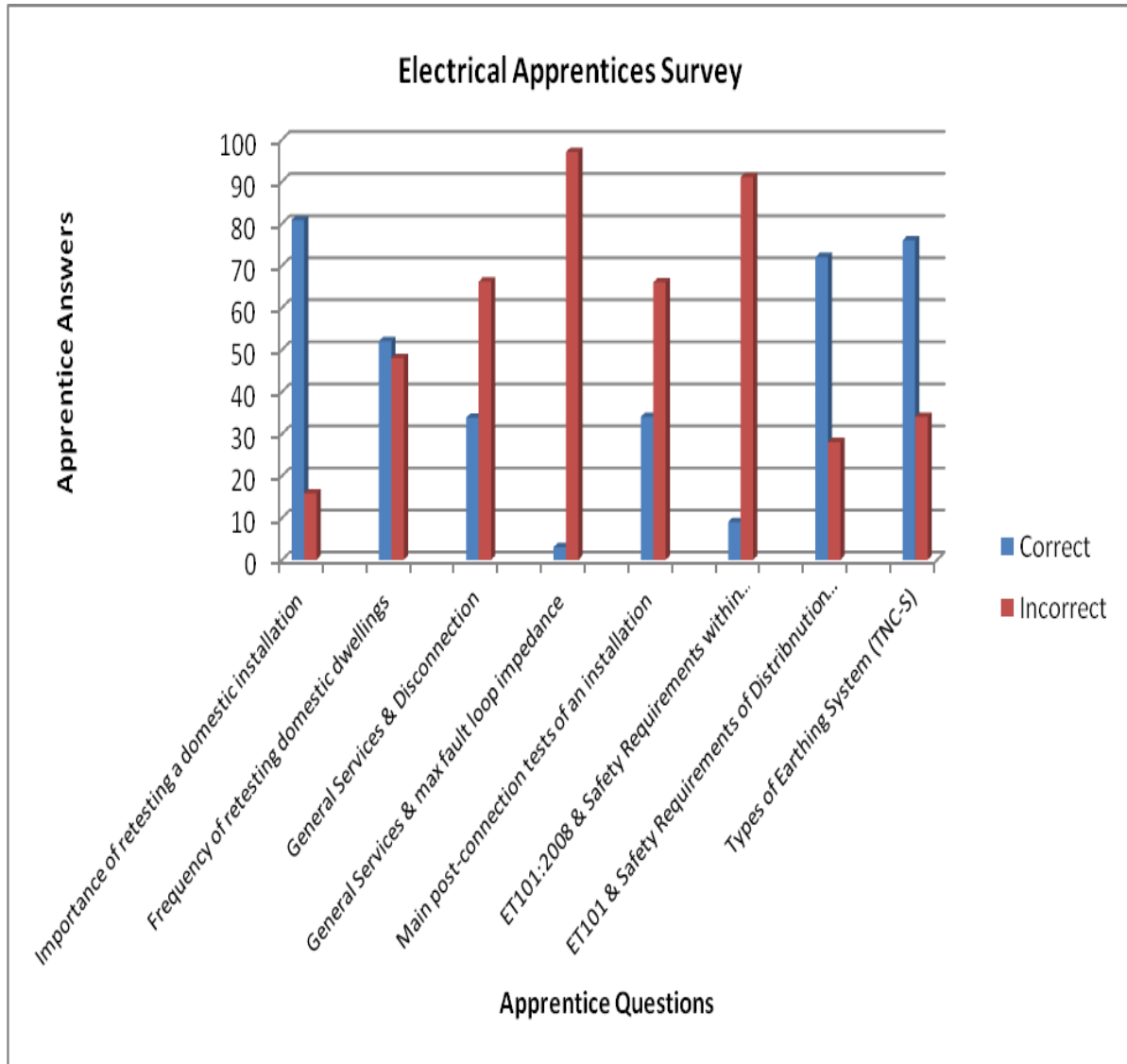

Figure 5.9.4 – Response to question No. 9 – Cleansed data

Summary of results



Chapter Six

Audit of (Domestic) Electrical Installations

6.1 Chapter Six – Audit of (Domestic) Electrical Installations

6.2 Introduction

This section will outline how a number of domestic installations were evaluated with respect to compliance with the requirements of ET101:2008. The inspection/testing regimes were designed so as to identify breaches in the required practices as defined in ET101:2008. Analysis of the results was implemented using a range of software (Adobe professional, Form Central, SPSS)

6.3 Rationale

The context of the audits was to identify the quality of the electrical installations and safety breaches which could create a potential to cause harm to the occupier. It is important to point out that the audit was undertaken with assistance from a registered electrical contractor. Where breaches were identified during the audit, said breaches were relayed on to the owner/occupier so that they could engage professional services to have said breaches addressed.

The tests themselves were divided into three categories:

1. *Low Level of non-compliance*

These include peripheral aspects such as visual quality and the age of the installation.

2. *Medium level of non compliance*

A medium level of non-compliance is defined as piece of equipment or part of the electrical installation which doesn't comply with the current standard ET101:2008, but does not present (with reasonable likelihood or probability) in its own right a high degree of risk or potential to cause (fire) danger or harm

3. *High level of non-compliance*

In such instances, breaches defined under this category need to be addressed and/or corrected immediately. An example of which would be deficits in the earthing system or malfunctioning RCDs

A range of scenarios are presented in 6.4 and the tabulated results are examined on this basis.

6.4 Analysis

The following is a sample interpretation of the acquired results. The analysis was implemented using the SPSS statistical package. The SPSS programme allows for basic results and also some cross tabulation of the results. The results will consider a range of areas associated with the dwellings and gauge the frequencies found.

The naming convention in the tables within SPSS, data and variable views was considered necessary for the non -electrical readers of this study who would be unaware of what the variables were and what they represented in the context of the dwelling.

6.4.1 Categorisation of the domestic dwellings

The first analysis will consider the overall level of compliance within the 15 domestic dwellings as found. Table 6.3.1 outlines the context of the installations across Dublin.

Table 6.4.1 – Breakdown of installation demographics

Location		Frequency	Percent	Valid Percent	Cumulative Percent
Valid	Dublin 15	1	6.7	6.7	6.7
	Dublin 11	3	20.0	20.0	26.7
	Dublin 12	2	13.3	13.3	40.0
	Dublin 6	1	6.7	6.7	46.7
	Dublin 9	2	13.3	13.3	60.0
	Dublin 7	1	6.7	6.7	66.7
	Dublin 16	2	13.3	13.3	80.0
	Dublin 5	3	20.0	20.0	100.0
	Total	15	100.0	100.0	

Table 6.4.2 illustrates that with respect to the number of installations involved in the audit, 40% of said installations are found to be not in compliance with ET101:2008

Table 6.4.2 – Summary Results concerning installation compliance

Compliance Final Result		Frequency	Percent	Valid Percent
Valid	Pass	9	60.0	60.0
	Fail	6	40.0	40.0
	Total	15	100.0	100.0

Next, the analysis focused on the level of compliance with respect to the house type. Table 6.3.3 details the make-up of dwelling type, whereas Table 6.3.4 details the level of compliance with respect to the installation year of construction.

Table 6.4.3 – Residential type summary

Residential Type		Frequency	Percent	Valid Percent
Valid	Semi-detached	9	60.0	60.0
	Terraced	4	26.7	26.7
	Apartment	2	13.3	13.3
	Total	15	100.0	100.0

Table 6.4.4 – Range of contraction year across sample of domestic electrical installations

Year of Construction		Frequency	Percent	Valid Percent	Cumulative Percent
Valid	Pre 1960	2	13.3	13.3	13.3
	1960-1980	9	60.0	60.0	73.3
	1981-1990	1	6.7	6.7	80.0
	1991-2000	1	6.7	6.7	86.7
	2000-2008	2	13.3	13.3	100.0
	Total	15	100.0	100.0	

6.4.2 Outcomes of Domestic Installation Audit

The quality of workmanship or installation is considered an important parameter underpinning electrical safety. Table 6.4.5 outlines how this consideration with respect to the degree of non-compliance.

Table 6.4.5 – Quality observed within the installation sample set

Quality of Electrical Installation		Frequency	Percent	Valid Percent
Valid	Low Level of non-compliance	5	33.3	33.3
	Medium Level of non-compliance	8	53.3	53.3
	High Level of non-compliance	2	13.3	13.3
	Total	15	100.0	100.0

SPSS facilitates statistical cross-referencing of results. Table 6.4.6 presents the age of the installation with respect to the level of bonding prevalent in the installations. Related to this consideration is the age of the installation with respect to the age of earthing systems (as illustrated in Table 6.3.7), both of these safety systems are of paramount importance with respect to protection of life.

Table 6.4.6 – Cross-referencing bonding standards against the age of the installation

Bonding and Protection:			Age of Wiring				Total
			1960 to 1980	1980-1990	1991 -2000	2001-2008	
Pass	Residential Type	Semi-detached	1	4	1	0	6
		Terraced	3	0	0	0	3
		Apartment	0	0	0	1	1
	Total	4	4	1	1	10	
Fail	Residential Type	Semi-detached	3		0	0	3
		Terraced	0		1	0	1
		Apartment	0		0	1	1
	Total	3		1	1	5	
Total	Residential Type	Semi-detached	4	4	1	0	9
		Terraced	3	0	1	0	4
		Apartment	0	0	0	2	2
	Total	7	4	2	2	15	

Table 6.4.7 – Cross-referencing main earthing requirements against the age of the installation

Main Earthing:			Age of Wiring				Total
			1960 to 1980	1980-1990	1991 -2000	2001-2008	
Pass	Residential Type	Semi-detached	2	4	1	0	7
		Terraced	3	0	0	0	3
		Apartment	0	0	0	2	2
	Total	5	4	1	2	12	
Fail	Residential Type	Semi-detached	2		0		2
		Terraced	0		1		1
	Total	2		1		3	
Total	Residential Type	Semi-detached	4	4	1	0	9
		Terraced	3	0	1	0	4
		Apartment	0	0	0	2	2
	Total	7	4	2	2	15	

The distribution boards at each installation were tested for compliance. Table 6.4.8 outlines the level of compliance observed with the sample.

Table 6.4.8 – Distribution board audit & associated (sample) compliance

Compliance Final Result:			Distribution Board Result		Total
			Pass	Fail - Did Not Trip	
Pass	House Audit	House	1		1
		House	1		1
		House	1		1
		House	1		1
		House	1		1
		House	1		1
		House	1		1
		House	1		1
		House	1		1
	Total			9	
Fail	House Audit	House	0	1	1
		House	0	1	1
		House	0	1	1
		House	0	1	1
		House	1	0	1
		House	0	1	1
	Total			1	5
Total	House Audit	House	1	0	1
		House	0	1	1
		House	0	1	1
		House	0	1	1
		House	1	0	1
		House	0	1	1
		House	1	0	1
		House	1	0	1
		House	1	0	1
		House	0	1	1
		House	1	0	1
		House	1	0	1
		House	0	1	1
		House	1	0	1
		House	1	0	1
		House	1	0	1
	Total			10	5

	HouseAudit	DateofAudit	Location	ResidentialType	ConstructionType	YearofAudit
1	House 1	15/03/2011	Dublin 11	Terraced	Block	
2	House 2	31/03/2011	Dublin 12	Terraced	Block	
3	House3	06/05/2011	Dublin 6	Semi-detached	Block	
4	House 4	22/08/2011	Dublin 12	Terraced	Mass Concrete	
5	House 5	11/02/2012	Dublin 16	Semi-detached	Block	
6	House 6	26/02/2011	Dublin 16	Semi-detached	Block	
7	House 7	29/11/2011	Dublin 15	Apartment	Block	
8	House 6	03/03/2012	Dublin 11	Apartment	Block	
9	House 9	19/03/2011	Dublin 15	Semi-detached	Block	
10	House 10	07/04/2012	Dublin 9	Terraced	Block	
11	House 11	10/03/2012	Dublin 9	Semi-detached	Block	
12	House 12	21/04/2012	Dublin 7	Semi-detached	Block	
13	House 13	05/05/2012	Dublin 5	Semi-detached	Block	
14	House14	19/05/2012	Dublin 5	Semi-detached	Block	
15	House 15	19/05/2012	Dublin 5	Semi-detached	Block	

Figure 6.34.1 – Parameterisation within SPSS (screen shot)

6.5 Conclusion

Of the 15 domestic installations that underwent the auditing process, 60% of them were found to have at least one safety concern. In the majority of instances, the RCD was found to be missing and therefore no supplemental earthing provision protection was provided. This presents a very serious situation as in the context of an aging building stock, it was obvious that the age of installations and therefore the integrity of the associated systems (including earthing) could become compromised in the near future.

Chapter Seven

Discussion

7.1 Chapter Seven – Discussion – Introduction

This section sets out, as a background to the development of the new regulatory model, an overview of the current regulatory model in operation. It presents the key elements of this regulatory model and the key strengths and weaknesses of this as identified by the Commission and industry stakeholders. These are key factors influencing the Commission’s approach to the objectives for, and design of, the new regulatory model.

7.2 Existing Regulation of Electrical Contractor Safety

It should be noted that the term “electrical contractors” and/or “registered electrical contractors” in this document refer to an electrical contracting entity. This may be either an individual sole trader operating as the electrical contractor or may be a larger operation, constituting many individual operatives. The terms relate to the party with whom the customer will have, or has, entered into the contract for the carrying out of electrical works.

The electrical contracting industry, at the low voltage level, has been self-regulated since 1992, with industry standards in place since 1972.

In 2000, a review was carried out by an Interdepartmental/Agency Review Group on Public Safety concerning the regulation of electrical contractors. At the subsequent request of the then Minister for Public Enterprise, the Commission recommended a regulatory system for electrical contractors that:

- built on the strengths of the voluntary system;
- addressed the weaknesses that existed; and,
- provided the Commission with statutory authority to act as Supervisory Regulator with the power to issue licenses to self-regulatory bodies in the then upcoming Electricity Bill.

Until such statutory authority was provided, the Commission agreed to assume the role of Supervisory Regulator.

In August 2002, an implementation timetable for the new approach was agreed and published. A working group was established and was tasked with developing detailed draft criteria, for approval by the

Commission, for the issue of a regulatory license by the Commission to Electrical Contracting Regulatory body or bodies who met these criteria. Draft Criteria were published on the 6th November 2002.

Following review by key industry stakeholders and a number of consequent amendments, the Criteria Document was approved by the Commission on 18th June 2004. It was also agreed at that time that the proposed new regulatory model be implemented on a voluntary basis by all stakeholders to further improve safety and standards in electrical installation work in advance of legislation which put the system on a firm statutory basis. This voluntary approach to the regulation of the industry was formally launched by the Minister for Communications, Marine and Natural Resources on the 23rd September 2004.

Since June 2004, the voluntary system has continued to operate with self regulatory bodies taking on board the requirements of the Criteria Document, with the Commission acting in an oversight role.

Those self-regulatory bodies currently operating within this voluntary system are:

The Registered Electrical Contractors of Ireland, or RECI; and, the Electrical Contractors Safety and Standards Association, or ECSSA.

7.3 Existing Regulatory Model

This existing regulatory model, as prescribed by the current Criteria Document is posited on three key elements:

1. Electro-Technical Standard

- The industry standard, “*ET 101 – the National Rules for Electrical Installations*,” (it being the latest published version, “the National Wiring Rules”) has been developed and published by the Electro-Technical Council of Ireland (“ETCI”) - the national body responsible for the harmonisation of standards in the Electrotechnical field, operating in collaboration with the National Standards Authority of Ireland (NSAI);
- This industry standard provides the fundamental basis upon which the existing regulatory system is founded given that it is the standard which electrical contractors must adhere to in the course of their work;

- The scope of these Rules apply to electrical circuits supplied at nominal voltages up to and including 1000V a.c. or 1500V d.c. which form part of installations in residential, commercial, industrial or public premises, or of installations contained in prefabricated buildings, caravans and halting sites,
- as well as installations for specialised purposes, such as those in agricultural and horticultural holdings.
-

2. Connection Policy and Supervisory Bodies - Self-Regulatory Bodies

- Currently, the primary incentive for adherence to the provisions of the National Wiring Rules is that the connection policy of the Distribution System Operator (DSO) requires that, in order for any new installation to be energised, it must be certified as being in accordance with the National Wiring Rules. Furthermore, the Building Regulations require that all installations be in compliance with the National Wiring Rules;
- Certification can only be provided under circumstances where:

(1) Members of the two self-regulatory bodies, being RECI and ECSSA, have carried out the work in accordance with the requirements of their regulatory body and certified it further to testing the installation; or,

(2) Where, further to testing and inspection of the installation by an inspector of one of the regulatory bodies, the inspector endorses/authenticates the certification of an installation carried out by a non-member of a regulatory body;

- The self-regulatory bodies only accept electrical contractors as members of their body if their operations meet certain minimum requirements which include

(1) having appropriate training and qualifications to undertake, test and certify electrical work and

(2) having suitable insurance to cover their work. Members are obliged to always work in conformance with the National Wiring Rules;

- Thus, the self-regulatory bodies currently provide a mechanism of confirming that their members possess the necessary training and competence to undertake electrical work in accordance with the National Wiring Rules. They undertake an inspectorate role to ensure members conform to the above minimum requirement and standards. Members who are found to contravene above requirements are subject to disciplinary proceedings by the self regulatory body;

- The self-regulatory bodies also undertake other functions with respect to dealing with customers and handling complaints relating to Registered Electrical Contractors.

3. Certification System

The current system requires that only certificates in the form of the ETCI Completion Certificate are valid. This forms a declaration to the customer that the installation has been installed and tested in accordance with the required standard by a member of one of the self-regulatory bodies.

The Completion Certificate system has been successful in providing this confirmation to customers and improving the overall standards of electrical works in Ireland given that:

- The sale of ETCI Completion Certificates is restricted by the ETCI to the self-regulatory bodies only;
- The subsequent issuance of ETCI Completion Certificates by the self regulatory bodies is restricted to its members only;
- The connection policy requirement of the DSO to only energise new installations on receipt of a valid Completion Certificate from members of the self-regulatory bodies, thereby incentivising customers to only use registered members of the self-regulatory bodies, and electrical contractors to become members of the bodies;
- Only members of a self-regulatory Body have the right to self certify his/her own work in accordance with the National Wiring Rules and the issuance of an ETCI Completion Certificate for such;
- The Completion Certificate itself provides the audit trail for the self regulatory body to undertake the follow up audit and inspection of the work of a registered member and, thus, a means to assess the competence of that member.

Figure 7.3.1 – Illustrates the operation of the current regulatory model.

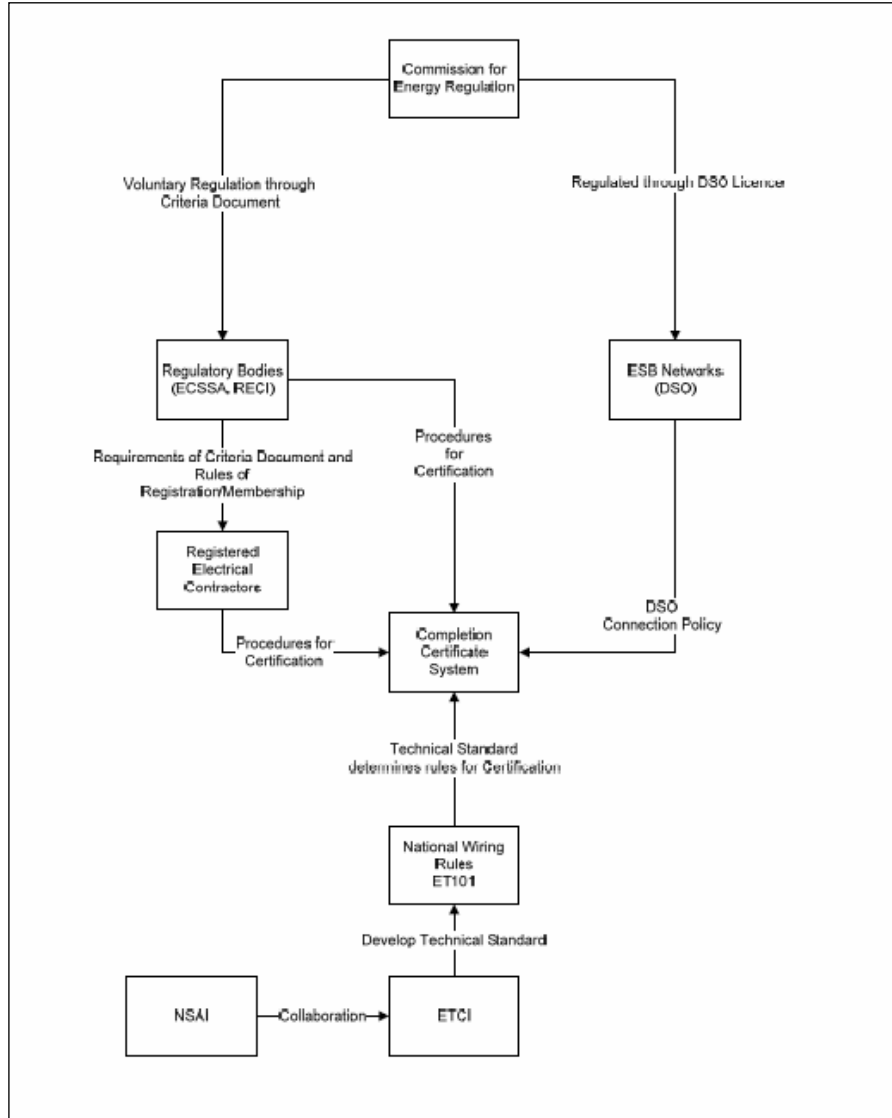

7.4 Scale of Current System

It is estimated that approximately 120,000 Completion Certificates are issued annually by Registered Electrical Contractors or further to direct inspections carried out by the self-regulatory bodies.

Furthermore, there is the region of 5,200 Registered Electrical Contractors in Ireland currently. These are individuals (sole traders) or collective entities (partnerships/companies) registered with either of the current self-regulatory bodies.

7.5 Legislative Requirements Concerning the New Regulatory Model

There are a number of Acts and Regulations which are relevant to the regulation of the electrical contractors with respect to safety. However, the single most important piece of legislation relating to this area is the *Energy (Miscellaneous Provisions) Act 2006* as this places direct requirements on the Commission concerning the regulation of electrical contractors.

The main requirements arising from the relevant legislation as relating directly to the regulation of electrical contractors are set out in this Section. These provisions and requirements will form the blueprint for the Commission's design of the new regulatory model.

7.6 Energy (Miscellaneous Provisions) Act 2006 – No. 40 of 2006

This Act places several new duties and functions on the Commission including specific functions concerning the regulation of both electrical installers and gas installers with respect to safety.

With respect to the regulation of electrical contractors with respect to safety, Section 4, sub-section (9) (C) of the Act states that:

“It shall be a function of the Commission to regulate the activities of electrical contractors with respect to safety”.

The Act includes specific provisions and responsibilities in broadly seven areas:

1. The role of the Criteria Document within the regulatory system;
2. The designation, functioning, operation, and monitoring of Electrical Safety Supervisory Body or Bodies (“the Designated Body”);
3. Obligations on electrical contractors who are registered with a Designated Body;

4. The implementation and operation of appeals procedures relating to a decision made by a Designated Body to suspend or revoke membership;
5. The determining of class or classes of work as works which require a Completion Certificate. Furthermore, the form and procedures relating to the issuance of a Completion Certificate, and the development of regulations by the Commission which makes it an offence for non-registered electrical contractors to undertake certain Restricted Works;
6. Third party inspections and Certification of Electrical Installations; and,
7. The appointment and powers of Authorised Officers and Appeals Officers;

7.7 Other Legislation concerning Electrical Safety

The following are other areas of legislation which will influence the new regulatory model:

Electricity Regulation Act 1999 – No. 23 of 1999

The Commission was established under the Electricity Regulation Act, 1999.

Under that Act, Section 9, sub-section (4) the Commission have the responsibility to *“have regard to the need...to promote safety and efficiency on the part of electricity undertakings”*

Thus, the Commission, in discharging its function to regulate the activities of electrical contractors with respect to safety, may support this approach via the promotion of safety and efficiency on the part of electricity undertakings.

Any new requirements which may be placed upon the DSO as part of the new regulatory model can be addressed in its license.

Other Legislation

Whilst there are other pieces of legislation which will influence the operation of the new regulatory model, they may not necessarily influence the design of the new regulatory model and, hence, are not discussed here.

Such legislation includes the following:

- Safety, Health and Welfare at Work Act 2005;
- Qualifications (Education & Training) Act 1999;
- National Standards Authority of Ireland Act 1996,
- Building Control Act 1990 and the Building Regulations.

The Commission will take cognisance of this other legislation in operating the new regulatory model and will engage with the parties with responsibilities for the enforcement of such legislation to ensure that there is no duplication of functions.

Chapter Eight

Conclusions & Recommendations

8.1 Chapter Eight – Conclusion and Recommendations

These sections will summaries the work in terms of the defined goals and object provided in the introduction to the thesis.

8.2 Main Findings of Dissertation

The audit undertaken provided an insight into the quality of the 15 installations examined. It showed a number of things relating to age of the wiring, year of construction and quality of the installation in relation to compliance with the present National Rules for Electrical Installations. The results showed that 60 % of houses carried a certain level of fault while 40% were considered to be up to standard

The focus of this study was to ascertain the opinion and views of electrical practitioners' from both educational and practical perspectives and the processes underpinning the Verification and Certification of Electrical Installations. Two questionnaires and a survey were conducted that engaged the following stake holders in the electrical services industry

1. *Standards-Based Apprenticeship (electrical) – Phase 6 students – N = 112*
2. *Registered Electrical Contractors – N = 19, 100%*
(ECSSAI – N = 5, 26%; RECI – N = 7, 37% Unknown – N = 7, 37%)
3. *Audit of Domestic Electrical Installations – N = 15*

A summary of the findings therein are as follows:

- The general awareness of the participants in respect of the CER's criteria documents was moderate to good. 83% of respondents were qualified certifiers,
- 100% reported that they attended a course to update their knowledge and skills in the previous five years. 1
- 8% reported that they were trained to perform artificial respiration and trained in the use of AED
- 73% had a basic knowledge of first aid.
- 23% of respondents reported that they had received accredited training in verification and testing of electrical installations in Potentially Explosive Atmospheres

Respondents reported that had knowledge of the following documentation in respect of electricity;

<i>Ref:</i>	<i>Document:</i>	<i>Responses</i>
1	CER Criteria Documents	77%
2	Safety, Health and Welfare at Work Act 2008 – No.	92%
3	10 of 2005	62%
4	SHWW (General Application), Regulations S.I. 299 of 2007	69%
	SHWW (Construction), Regulations S.I. 504 of 2006	N =14

Respondents reported that had an awareness of electrical safety responsibility:

<i>Ref:</i>	<i>Document:</i>	<i>Responses</i>
1	Electrical risk assessment	91%
2	Safety statement preparation (electrical Hazards)	91%
3	Explosion prevention document	18%
4	National Rules for Electrical Installations in Potentially Explosive Atmospheres – ET105:2011	45%
		N =12

The educational aspects of Verification and Testing were carried out in a diligent manner and with academic rigor. The Phase 6 students surprisingly failed to appreciate the depth of knowledge required to conduct Verification and Testing.

In fact the questionnaires suggest that the details required for the Verification and Testing process were not fully appreciated until the post qualification period; when the electrician had acquired adequate practical experience and had attained the opportunity to have the responsibility for the Verification and Testing process and is required to sign-off completion certificates and sub-system completion certificates.

Verification and Certification of Electrical Installations must be in accordance with the National Rules for Electrical Installations ET 101: 2008 – 4th Edition and any amendments to the rules.

Regulation S.I. 299 (part 3) of the Safety, Health and Welfare at Work General Application), Regulations (2007) outlines requirements with respect to verification and testing of electrical installations. It is also suggested that the training of Qualified Certifiers be carried out post apprenticeship when the electrician has acquired three year post apprenticeship experience, the responsibility of ensuring that adequate training in respect of Verification and Testing should continue to be the responsibility of the Safety Supervisory Bodies. Since the 5th January 2009 the Commission for Energy Regulation (CER) is responsible for the regulation of Registered Electrical Contractors with respect to safety. Only a “Qualified Certifier” is entitled to issue completion certificates and sub-system certificates for Controlled Works. According to the regulations a *Qualified Certifier* must have completed a recognised training course on Verification and Certification of Electrical Installations within the previous three years

The Commission for Energy Regulation (CER) will regulate enforcement through the safety supervisory bodies. This means that a significant number of electricians working in the industry are now required to attend a recognised Verification and Certification course periodically (as prescribed by CER) to fulfil the requirements of the regulatory system.

8.3 Summary report of Audit on domestic electrical installations

The focus of the study was to ascertain the quality of existing domestic electrical installations; N = 15 domestic electrical installations in the Dublin area were inspected and a number of specific parameters were identified as follows:

- (i) Residential type and age of installations
- (ii) Distribution Board protection Fuses, MCB's and RCD's
- (iii) Functional performance of protective devices
- (iv) Circuit functionality
- (v) Earthing system, Earth fault loop impedance, prospective fault currents and workmanship in respect of earthing.

The following detail summarises findings from these (domestic) wiring installation inspections

(ii) Distribution Board protection Fuses, MCB's and RCD's

An inspection of 15 domestic dwellings revealed that there is a marked difference between the workmanship and functionality of electrical distribution boards. Figure 8.3.1 illustrates the arrangement in pre 1960's dwellings. The entire electrical distribution control is located with a fuse board which typically serves the dwelling. A main isolator is located to the right of the fuse board.

Electrical protection is provided by two DZ fuses. The absence of Residual Current Devices (RCD's) is evident. The electrical fuse board is mounted on a timber structure with no fire retardant material backing the fuse board. There is no labelling present to indicate to the consumer the functionality of the protective devices.



Figure 8.3.1 – Pre 1960's fuse board with coin metre

There is a significant difference in an early 1980's distribution fuse board – particularly as same has dramatically increased in size which is evident in Figure 8.3.6.

The fuse board lay-out which consists of an isolator and a variety of fuse sizes is located beside the ESB's service cut-out containing an 80 amp. HRC fuse.

The distribution fuse board contains a 63 amp. Main fuse, a 35 amp cooker circuit, and adequate lighting and socket circuits. A bell transformer is located adjacent to the fuse board. An attempt has been made to label the electrical circuits and the fuse board is mounted on a fire-resistant base.

This fuse board was consistent type found in the pre 1970 housing during the study



Figure 8.3.2a



Figure 8.3.3 – Pre 1980's fuse board with service cut-out and metre

Once again it is evident that there is no RCD protection associated with this fuse board.

Post 1980's electrical installations

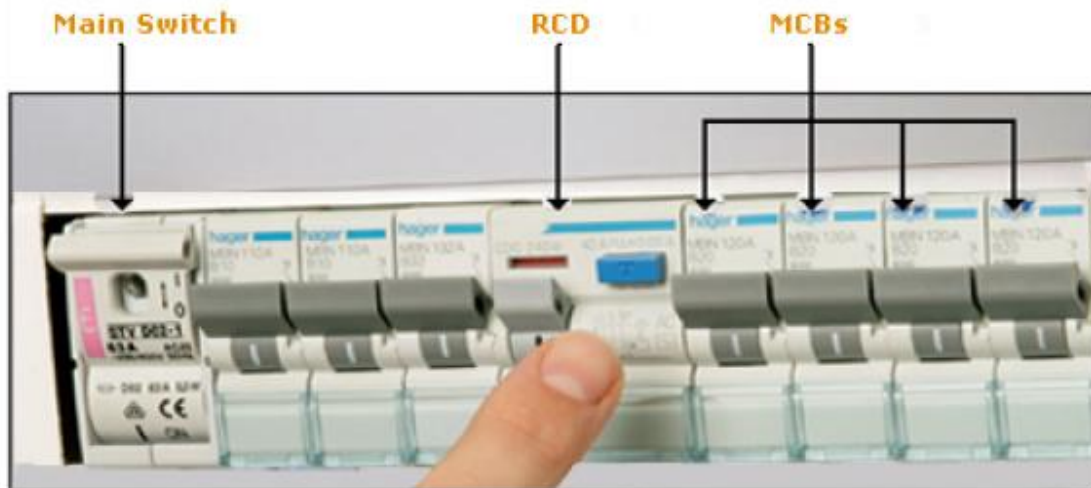

Figure 8.3.4 – Post 1980’s distribution board (consumer unit)

RCD are now mandatory in all domestic electrical installation; Figure 8.3.4 above is for illustrative purposes. It must be noted that all electrical work in domestic electrical installations involving distribution boards must be carried out by a Registered Electrical Contractor.

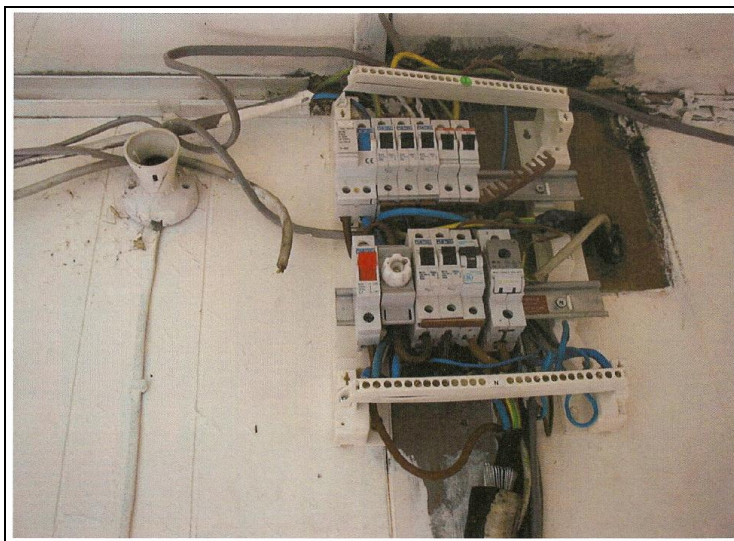

Figure 8.3.6 – Post 1980’s distribution board (consumer unit); Unacceptable

(iii) Functional performance; the use of modern distribution boards does not necessarily mean that the functional performance of protective devices are adequate in respect of electrical safety. Figure 8.3.6 is a post 1980’s installation; the distribution board contains all the necessary protective devices including an RCD and a variety of MCB’s etc. however, even to the non-electrical expert this distribution board is clearly an electrical hazard. The workmanship is clearly inadequate, a variety

of omissions e.g. no fire retardant material, exposure to shock with the enclosure cover missing, no labelling etc. the need to use Registered Electrical Contractors cannot be overstated



Figure 8.3.7 – 1990's distribution board (consumer unit) with warning label attached

(iv) Circuit functionality and their protective devices are intrinsic to electrical safety; consider Figure 5.11.8 this shows cooker control unit incorporating a 13 amp. socket-outlet in the pre 1960's electrical installations this unit would be protected by a 35 amp. DZ fuse; no RCD protection was required.

The cooker control unit is located in a kitchen; an additional flexed-outlet has been added, the cooker circuit has no mechanical protection and is draped across the cooker which is an added fire hazard. Circuit functionality has been compromised rendering the electrical protection void and the circuit has become a shock and fire hazard.



Figure 8.3.8 – Circuit functionality and protective devices

Circuit functionality is compromised as depicted in Figure 8.3.9 the details relate to a bathroom setting; the offending circuit shows an extract fan with an electrical pendant “hooked-into –the-circuit”.

The circuit is located directly above a shower stall (see curtain rail directly below the fixture); this is contrary to the requirements of the National Rules for Electrical Installations – ET101:2008. Not only is the circuit protection compromised; it is likely that the earthing system is inadequate and even to the untrained eye this is obviously an extremely dangerous situation.

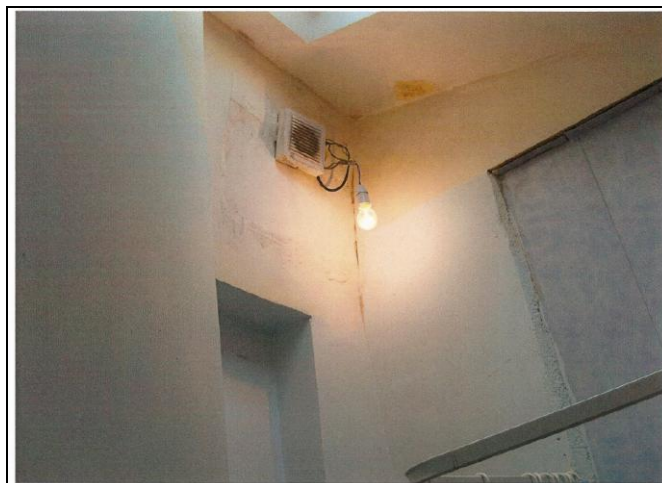

Figure 8.3.9 – Circuit functionality and extract fan

In modern day electrical installations circuit functionality may be compromised by the wide-spread deployment of technological services.

Circuits as depicted in Figure 8.3.10 where one socket-outlet is used to serve a multitude of devices, such as multi-media apparatus, in work station applications serving desk-top computers and multiple peripheral devices such as printer, scanner, speaker systems and a array of support equipment as now common-place.

Inadequate design parameters can lead to circuit over load and this may give rise to fire hazards in addition to electrical hazards – in an industrial application such devices are subject to portable appliance testing (PAT); in a domestic electrical installation the concept of PAT is not required.



Figure 8.3.10 – Circuit functionality compromised by over load

(v) Earthing System and the use of anti-vibration earth clamps; Earthing and equipotential bonding are intrinsic in terms of electrical safety. Figure 8.3.11 illustrates a common fault found in pre 1980's premises. It is well established that water-pipes are subject to vibration due to the flow of water through them. Earthing clamps used for earthing and equipotential bonding purposes must be adequately installed to withstand this vibration.

Earthing clamps may be rendered useless if water-pipes are painted...paint may run between the pipe and the clamp connection, since most paints have insulating properties this can in effect reduce

electrical conductivity and prevent fault current and spurious faults currents from flowing; these fault currents enable protective devices to operate.

It has been demonstrated that the need for re-testing of electrical installations is imperative in order to protect owner/occupiers. Figure 8.3.12 illustrates the correct application of an earth clamp incorporating the correct anti-vibration connection with the “Safety electrical earth “do not remove” label is clearly visible on the earth clamp.



Figure 8.4.11 – Earth clamp connection

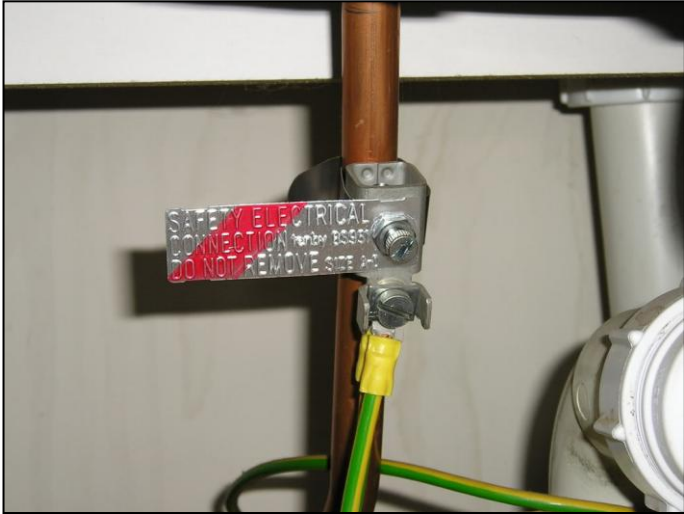

Figure 8.4.12 – Earth clamp connection with anti-vibration device

Details of the technical results can be obtained in Annex D of this study and recommendations in respect of survey in Chapter 7 – conclusions of the study.

8.4 Further research into Verification and Testing

Following on from Results and Analysis of the questionnaires and the survey, a significant finding from the study is that the whole area of Verification and Testing needs to be fully investigated to ensure that training providers are aware for the need to provide a standard approach to ensure that training is adequate and fit for purpose.

8.5 Role of CER in Verification and Testing

Following a study of CER's criteria documents and in particular Section C – The Registered Electrical Contractor, a significant finding of the study was a recommendation that the relevant part of the criteria document be altered to change the wording from recognised course to an accredited course. This finding is explored further in section 1.2.13 below.

1.2.13 Training and Competence of Qualified Certifier

1.2.13 A Qualified Certifier is required to satisfy the basic requirement of having:

- (i) Served a recognised apprenticeship as an electrician and having been awarded a National Craft Certificate; or,*
- (ii) another suitable electrical award, equivalent to Level 6 or higher on the National Framework of Qualifications; and is required to have successfully completed a recognised course in “Testing Verification and Certification” in the previous 3 years.*

Details of the Questionnaire and results can be obtained in Annex A of this study.

Results and recommendations in respect of two questionnaires and a survey can be found in Chapter 5 Analysis and Results and in Chapter 7 Conclusions of the study

REFERENCES

B Phillips 1971 Social Research, Strategy and Tactics. 2nd ed.

(Electricity:; S. -, et al. (1993 - 2007). "Safety Health and Welfare at Work (General Application Regulations) ": Part VIII- Part III.

Barrett and e. a. O'Connell (2010). "Analysis of electrical accidents in UK domestic properties." "Building Services Engineering Research Technology (accepted for publication)2010.

Barrington (1983). "Report of the commission of inquiry on safety, health and welfare at work."

CER "The Commission for Energy Regulation. Ireland."

ECSSAI "Electrical Contractors Safety & Standards Association Ireland Ltd."

ESB ""THE SAFE USE OF ELECTRICITY IN THE HOME"." Electricity Supply Board
www.esb.ie/esbnetworks

ESC (2011). "Electrical safety ignorance 'puts millions at risk'." <http://www.bbc.co.uk/news/uk-15741770> 16 November 2011(Electrical Safety Council.UK).

ET101:, E.-T. C. o. I. E. (2006). "National Rules for Electrical Installations, Third Edition,."

ETCI "The Electro Technical Council of Ireland."

ETCI (ET 101:2008). "National Rules and Regulations for Electrical Installations." (Fourth Edition).

FEEDS (2008 January 31st). "6th EΦA ROUNDTABLE " (Forum for European Electrical Domestic Safety).

Fink, A. (1995). "*How to ask survey questions*". Thousand Oaks, CA: Sage Publications.

Finneran, M., F. Statistics, et al. (10 Nov 2009). "House Fire Statistics: House Fire Statistics " (John Cregan: ...373: To ask the Minister for the Environment, Heritage and Local Government the main causes of house fires here, where lives have been lost; and if he will make a statement on the matter. [40420/09]

HSA "Electrical Fatalities in Ireland 1995.-2010" Health and Safety Authority Ireland.

Leonardo Energy (January.2010). "Electrical Safety in the home." The Global Community for Sustainable Energy Professionals(http://www.leonardo-energy.org/webfm_send/3651).

RECI "Registered Electrical Contractors of Ireland Ltd."

RECI/news (October 2011). JOURNAL OF THE REGISTER OF ELECTRICAL CONTRACTORS OF IRELAND Voltimum.

Samuelson-Brown, G. and M. Thornton (1997). "Repair, maintenance & improvement in housing - electrical supply, the supply side." BSRIA.

R. Belmans, H. De. Keulanaer, J. Manson, and E. Schellekens, "Towards improved electrical installations in European homes," European Copper Institute, 2004.

Cadick, M. Capelli-Schellpfeffer, and D. Neitzel, *Electrical safety handbook*, 3rd ed. New York, United States of America: McGraw Hill Companies, 2006.

British Standard Institution, "Code of Earthing Practice," BSI, Milton Keynes, Standard BS7430, 1998.

T. Bernstein, "Electrical Shock Hazards and Safety Standards," *IEEE Transactions on Education*, vol. 34, no. 3, pp. 216-222, August 1991.

Morgan, D.L. (1998) 'Practical Strategies for Combining Qualitative and Quantitative Methods: Applications for Health Research', *Qualitative Health Research* 8: 362-76.

Section 1 – Safety, Health and Legislative requirements in relation to Electricity and Construction;
<http://www.hsa.ie/publisher/index.jsp?jSectionid=3e30244131141489192812> (date accessed 27 May 2012)

Code of Practice for the Management of Fire Safety in Places of Assembly (1991)” published by the Department of Environment. -
<http://www.environ.ie/en/LocalGovernment/FireandEmergencyServices/RHLegislation/FileDownload,2175,en.doc-35.0KB> –

Guide on Statutory Inspections – Scheduling Tool – State Claims Agency – 11th November 2009
<http://www.stateclaims.ie/Publications/GuidanceOnStatutoryInspectionsSchedulingTool.pdf>
Date accessed 28th May 2012

http://www.hsa.ie/eng/Topics/ATEX_and_Electrical_Apparatus/
(This web-site was accessed on 28th May 2012)

http://www.hsa.ie/eng/Publications_and_Forms/Publications/Retail/Gen_Apps_Explosive_Atmospheres.pdf
(This web-site was accessed on 28th May 2012)

http://www.hsa.ie/eng/Legislation/Acts/Safety_Health_and_Welfare_at_Work/
(This web-site was accessed on 28th May 2012)

ET214:2005 Application Selection of RCD <http://www.etcie.ie/docs/ET214.pdf>
(This web-site was accessed on 28th May 2012)

Fire Services Act 1981 – No 30 of 1981 –
<http://www.irishstatutebook.ie/1981/en/act/pub/0030/index.html>

The Criteria Document consists of a series of Common Procedures <http://www.cer.ie/en/electrical-safety-criteria-document.aspx> (Date accessed 5 June 2012)

<http://www.etcie.ie/docs/ET214-2005.pdf>

(This web-site was accessed on 28th May 2012)

<http://www.environ.ie/en/Publications/DevelopmentandHousing/Housing/FileDownload,19428,en.pdf>

(Date accessed: 23 April 2012)

Physiological Effects of the Combustion Products and Fire Hazard Assessment, Purser, David,
European Seminar “Safety during Fire” Brussels 6th may 2009

“RCDs Saving Lives” <http://www.etcie.ie/safety/videos.html> (Date accessed: 20th May 2012)

RCD Test Sticker on Your Distribution Board

<http://www.etcie.ie/images/rcdsticker.pdf> (Date accessed 20th May 2012)

CER – Definition of Controlled Works – CER/09/009 – 30th January 2009
CER – Section A – Introduction and Interpretation – CER/08/071A
CER – Section B – The Body – CER/08/071B
CER – Section C – The Registered Electrical Contractor – CER/08/071C
Code of Practice for Fire Safety of Furnishings and Fittings in Places of Assembly
Code of Practice for Safety at Indoor Concerts – Department of the Environment and Local Government
Code of Practice for the Management of Fire Safety in Places of Assembly
Criteria Document issued by the Commission for Energy Regulation
Electricity (Supply) Acts 1927 to 2004
Explosive Atmospheres at Places of Work – I
Fire Services Act 1981 No. 30 of 1981
Forum for European Electrical Domestic Safety Volume 1 – March 7th 2003
Guide to the Safety, Health and Welfare at Work
Guide to the Safety, Health and Welfare at Work (General Application) Regulations 2007 – Part 3 I
Guide to the Safety, Health and Welfare at Work (General Application) Regulations 2007 – Part 8 I
Guide to the Selection & Use of Residual Current Devices ET214:2005 February 2005 ETCI
National Rules for Electrical Installations ET101:2008 ETCI
National Rules for Electrical Installations in Potentially Explosive Atmospheres ET105:2011 ETCI
National Standards Authority of Ireland Act 1996 No. 28 of 1996
Safety, Health and Welfare at Work Act 1989 No. 7 of 1987
Safety, Health and Welfare at Work Act 2005 No. 10 of 2005
SHWW (Construction), Regulations 2006 S. I. 504 of 2006
SHWW (General Application), Regulations 2007 S. I. 299 of 2007

Appendix A

Contents of Appendix A

1. Letter to ECSSAI dated 24th April 2012
2. Letter to RECI dated 24th April 2012
3. Questionnaire

Michael Marshall,
General Manager,
Electrical Contractors Safety and Standards Association, (Ireland Limited)
Coolmore House, Park Road,
Killarney
County Kerry Email: info@ecssa.ie

24 April 2012

Re. Survey in respect of Verification and Testing of Electrical Installations in the Republic of Ireland

Dear Mr Marshall,

By way of introduction my name is Noel Masterson; I am a member of staff in the School of Electrical Engineering Systems, Department of Electrical Services Engineering, DIT Kevin Street, Dublin 8.

I am undertaking a survey into:

"Verification and Testing of
Electrical Installations in the
Republic of Ireland"

The results of the research will form part of the requirements for a Master of Science in Environmental Health and Risk Management – Dublin Institute of Technology.

The primary objective of the research is to determine to what extent, the process of verification and testing of electrical installations is carried out and the effectiveness of the testing process.

The survey will attempt to capture the perceptions and the views of Registered Electrical Contractors on this important topic.

I would be most grateful to you if you would circulate the questionnaire to Registered Electrical Contractors who are members of the Electrical Contractors Safety and Standards Association and I would appreciate it if you would encourage the REC's to complete the questionnaire.

The questionnaire was designed for ease of completion while at the same time collecting the maximum data. It should take you approximately 25 minutes to complete. I would be very grateful if your REC's could take the time to complete the questionnaire and to return it as soon as possible, but not later than Thursday, 24th may 2012.

The questionnaire itself is strictly confidential and anonymous: The participant's identification will not appear on the questionnaire.

Thank you for your help and co-operation

Noel Masterson,
Postgraduate student,
MSc in Environmental Health and Risk Management
Telephone: +353-1-402 4670
Fax: +353-1-402 4986
Email: noel.masterson@dit.ie

Paul Waldron,
General Manager,
Register of Electrical Contractors of Ireland,
Unit 9, KCR Industrial Estate,
Ravensdale Park,
Kimmage, Dublin 12. Pwaldron@reci.ie
24 April 2012

Re. Survey in respect of Verification and Testing of Electrical Installations in the Republic of Ireland

Dear Mr Waldron,

By way of introduction my name is Noel Masterson; I am a member of staff in the School of Electrical Engineering Systems, Department of Electrical Services Engineering, DIT Kevin Street, Dublin 8.

I am undertaking a survey into:

"Verification and Testing of
Electrical Installations in the
Republic of Ireland"

The results of the research will form part of the requirements for a Master of Science in Environmental Health and Risk Management – Dublin Institute of Technology.

The primary objective of the research is to determine to what extent, the process of verification and testing of electrical installations is carried out and the effectiveness of the testing process.

The survey will attempt to capture the perceptions and the views of Registered Electrical Contractors on this important topic.

I would be most grateful to you if you would circulate the questionnaire to Registered Electrical Contractors who are members of the Register of Electrical Contractors of Ireland and I would appreciate it if you would encourage the REC's to complete the questionnaire.

The questionnaire was designed for ease of completion while at the same time collecting the maximum data. It should take you approximately 25 minutes to complete. I would be very grateful if your REC's could take the time to complete the questionnaire and to return it as soon as possible, but not later than Thursday, 24th May 2012.

The questionnaire itself is strictly confidential and anonymous: The participant's identification will not appear on the questionnaire. Thank you for your help and co-operation.

Noel Masterson,
Postgraduate student,
MSc in Environmental Health and Risk Management
Telephone: +353-1-402 4670
Fax: +353-1-402 4986
Email: noel.masterson@dit.ie



College of Engineering & Built Environment,
School of Electrical Engineering Systems
Department of Electrical Services Engineering

Survey Into
"Verification and Testing of
Electrical Installations in the
Republic of Ireland"

Confidential

Thank you for taking the time to complete this questionnaire. The information that you volunteer is purely for Research Purposes and will be strictly **confidential**.

The questionnaire consists of 20 questions; it was designed for ease of completion and should take about 25 minutes.

The questionnaire is strictly confidential and anonymous: it will be coded upon receipt, your e-mail contact details will be removed and the researcher will not be aware of your identity when analysing the data.

The questionnaire should be returned to:

Noel Masterson, Postgraduate Student
Survey – “Verification and Testing”
Dublin Institute of Technology,
College of Engineering & Built Environment,
Department of Electrical Services Engineering,
Kevin Street, Dublin 8, Republic of Ireland

Please return the questionnaire on or before Thursday, 24th May 2012

IMPORTANT NOTICE:
PLEASE DO NOT INCLUDE YOUR NAME OF ANY
INFORMATION THAT CAN LEAD TO YOUR
IDENTITY ON THIS QUESTIONNAIRE

Please indicate to which organisation you belong by ticking the appropriate box ✓
 Below:

Commission for Energy Regulation (CER)	<input type="checkbox"/>
Electrical Contractors Safety & Standards Association (ECSSA)	<input type="checkbox"/>
Register of Electrical Contractors of Ireland (RECI)	<input type="checkbox"/>

Question No. 1

What is the CER's role in the regulation of the electrical contracting industry?

<p>Outline the role of the Commission for Energy Regulation (CER) below:</p>

Question No. 2

Do you have a **current copy** of the National Rules for Electrical Installations – ET101:2008?

Yes No

Question No. 3

What year did you qualify as an electrician?

Question No. 4

What qualifications do you possess; please tick ✓ the appropriate box below?

Time-served apprenticeship – Senior Trade Certificate	<input type="checkbox"/>
Standards-Based Apprenticeship National Craft Certificate (Electrical)	<input type="checkbox"/>
*Other qualification – please specify	<input type="checkbox"/>

<p>Other qualification (s):</p>
--

Question No. 5

How long are you a Registered Electrical Contractor; please tick ✓ the appropriate box below?

One to five years	<input type="checkbox"/>
Six to ten years	<input type="checkbox"/>
Over eleven years	<input type="checkbox"/>

Question No. 6

Please indicate the number of completion certificates completed in the following years:

Completion Certificates	Insert Number below
Completion certificates completed in respect of 2008	<input type="checkbox"/>
Completion certificates completed in respect of 2009	<input type="checkbox"/>
Completion certificates completed in respect of 2010	<input type="checkbox"/>
Completion certificates completed in respect of 2011	<input type="checkbox"/>

Question No. 7

Are you a qualified certifier of electrical installations?

Yes No

Question No. 7

If yes please indicate the number of years by ticking the appropriate box below:

One to five years	<input type="checkbox"/>
Six to ten years	<input type="checkbox"/>
Over eleven years	<input type="checkbox"/>

Question No. 8

When did you last attend a CPD course in up-dating your electrical Knowledge and skills please tick the appropriate box below?

Less than five years	<input type="checkbox"/>
Six to ten years	<input type="checkbox"/>
Over eleven years	<input type="checkbox"/>

Question No. 9

Are you aware of the following documents in respect of electricity? Please tick the appropriate Box below:

--	--

CER Criteria Documents	<input type="checkbox"/>
Safety, Health and Welfare at Work Act 2005 – No. 10 of 2005	<input type="checkbox"/>
SHWW (General Application) Regulations, S. I. 299 of 2007	<input type="checkbox"/>
SHWW (Construction) Regulations, S. I. 504 of 2006	<input type="checkbox"/>

Question No. 10

Have you received training in the procedures to be adapted in the event of an electrical accident, such as; please tick the appropriate box below?

Disconnection from the supply in the event of an electrical accident	<input type="checkbox"/>
How to call for emergency assistance	<input type="checkbox"/>
How to apply Artificial Respiration and the use of AED's	<input type="checkbox"/>
Basic first aid in the event of an electrical accident	<input type="checkbox"/>

Question No. 11

Have you received accredited training in Potentially Explosive Atmospheres?

Yes No

Question No. 12

If the answer to Q11 is yes please indicate the appropriate level of training by ticking the appropriate box below:

Basic Atex awareness course	<input type="checkbox"/>
Foundation course in Hazardous Areas	<input type="checkbox"/>
Accredited CompEx Training Course	<input type="checkbox"/>
Accredited IECEx Training Course	<input type="checkbox"/>

Question No. 13

Are you aware of your electrical safety responsibility in respect of the following please tick the appropriate box below?

Electrical risk assessment	<input type="checkbox"/>
Safety statement preparation (electrical hazards)	<input type="checkbox"/>
Explosion prevention document	<input type="checkbox"/>
National Rules for Electrical Installations in Potentially Explosive Atmospheres	<input type="checkbox"/>

Question No. 14

Do you have a current copy of the National Rules for Electrical Installations in Potentially Explosive Atmospheres – ET105:2011?

Yes No

Question No. 15

Do you believe that you are qualified to carryout work in Hazardous Areas or in Potentially Explosive Atmospheres with the need for further accredited training?

Yes No

Further Information

It would help the research considerable to have your brief comments on the following questions (please add additional sheets of paper if you feel the need to do so

Question No. 15

What is your opinion of the existing quality of the Inspection, Testing, Verification and Certification of electrical installations in the Republic of Ireland?

Question No. 16

Is the activity in respect of the Inspection, Testing, Verification and Certification of electrical installations in the Republic of Ireland of good quality?

Is the activity in respect of the Inspection, Testing, Verification and Certification of electrical installations in the Republic of Ireland carried out in a credible manner?

Question No. 18

Is the training and assessment of qualified certifier's in respect of the Inspection, Testing, Verification and Certification of electrical installations in the Republic of Ireland of good quality and credible?

Question No. 19

What changes would you like to see in respect of the training and assessment of qualified certifier's in respect of the Inspection, Testing, Verification and Certification of electrical installations in the Republic of Ireland?

Question No. 20

In relation to the frequency of training courses for qualified certifier's do you feel that a 3-year cycle is appropriate?

THANK YOU FOR COMPLETING THE QUESTIONNAIRE!

Formcentral Questionnaire Distributed online--- RECI website]

New Form 5/13/11 (Form File & Responses) - Windows Internet Explorer

https://formscentral.acrobat.com/app.html#d=ofIFAsgJD2JEj8X0lMvpA

adobe formcentral

FORMSCENTRAL New Form 5/13/11

Design Options Test Distribute View Responses Summary Report Upgrade

Arial 14 B I U A Labels on Top

College of Engineering & Built Environment,
School of Electrical Engineering Systems
Department of Electrical Services Engineering

A Survey Into:
"The Verification and Testing of
Electrical Installations in the
Republic of Ireland"

Confidential

Thank you for taking the time to complete this questionnaire. The information that you volunteer is purely for Research Purposes and will be strictly **confidential**.

The questionnaire consists of 20 questions; it was designed for ease of completion and should take about 10 minutes.

The questionnaire is strictly confidential and anonymous: it will be coded upon receipt, your e-mail contact details will be removed and the researcher will not be aware of your identity when analysing the data.

The questionnaire should be returned to:

Noel Masterson, Postgraduate Student
Survey – "Verification and Testing"
Dublin Institute of Technology,
College of Engineering & Built Environment,
Department of Electrical Services Engineering,
Kevin Street, Dublin 8, Republic of Ireland

IMPORTANT NOTICE:

PLEASE DO NOT INCLUDE YOUR NAME OF ANY
INFORMATION THAT CAN LEAD TO YOUR IDENTITY ON THIS QUESTIONNAIRE

Share Noel Masterson Author viewing Thomas Shannon Contributor Published

Done Internet 100%

Preview

DIT Email ... Window... New Form 5/13/11 (F... EN 10:17



Search

- [→ My Profile](#)
- [→ MY BASKET](#)
- [→ Log off](#)

- [Home](#)
- [Product Information](#)
- [Electrical News](#)
- [Technical Expertise](#)
- [Training](#)
- [Wholesalers](#)
- [Partners](#)

You are here: Home > Electrical News

- Manufacturers News [+](#)
- Industry News [+](#)
- News from Industry Partners [-](#)**
 - Latest News
 - [\) Browse by Industry Partners](#)
- Newsletters [+](#)
- Voltimum Out and About [+](#)

Survey in respect of Verification & Testing of Electrical Installations in the Republic of Ireland

11.06.2012



Noel Masterson, a member of staff in the School of Electrical Engineering Systems, Department of Electrical Services Engineering, DIT Kevin Street, Dublin 8, is undertaking a survey into:

"Verification and Testing of Electrical Installations in the Republic of Ireland"

The results of the research will form part of the requirements for a Master of Science in Environmental Health and Risk Management - Dublin Institute of Technology.

The primary objective of the research is to determine to what extent the process of verification and testing of electrical installations is carried out and the effectiveness of the testing process.

The survey will attempt to capture the perceptions and the views of Registered Electrical Contractors on this important topic.

The questionnaire was designed for ease of completion while at the same time collecting the maximum data. It should take approximately 25 minutes to complete. We would be grateful if you could take the time to complete and return the questionnaire at your soonest convenience (by early June if possible).

The questionnaire itself is strictly confidential and anonymous: the participant's identification will not appear on the questionnaire.

The questionnaire can be completed online by clicking [here](#). Alternatively the questionnaire can be downloaded by clicking [here](#). You can then, print it and return the filled-in questionnaire to the address specified on the first page.

Thank you for your help and co-operation.

[→ Back](#)

RELATED INFORMATION

- [→ Related links](#)
- [→ Related contacts](#)

MORE NEWS...

- [Qualified Certifier](#)
[→](#)
- [Draft I.S. 3217 on Emergency Lighting for Public Comment](#)
[→](#)
- [Emergency Lighting course in May 2012](#)
[→](#)
- [Training & Competence of Qualified Certifier](#)
[→](#)
- [Update on BESS Scheme for IS 3217](#)
[→](#)
- [Contractor Insurance](#)
[→](#)
- [Top 10 breaches of the ET101 National Rules for Electrical Installations](#)
[→](#)
- [Autumn 2011 training course schedule is now available](#)
[→](#)

Appendix B

Summary Report on Survey of Registered Electrical Contractors

Results of Survey

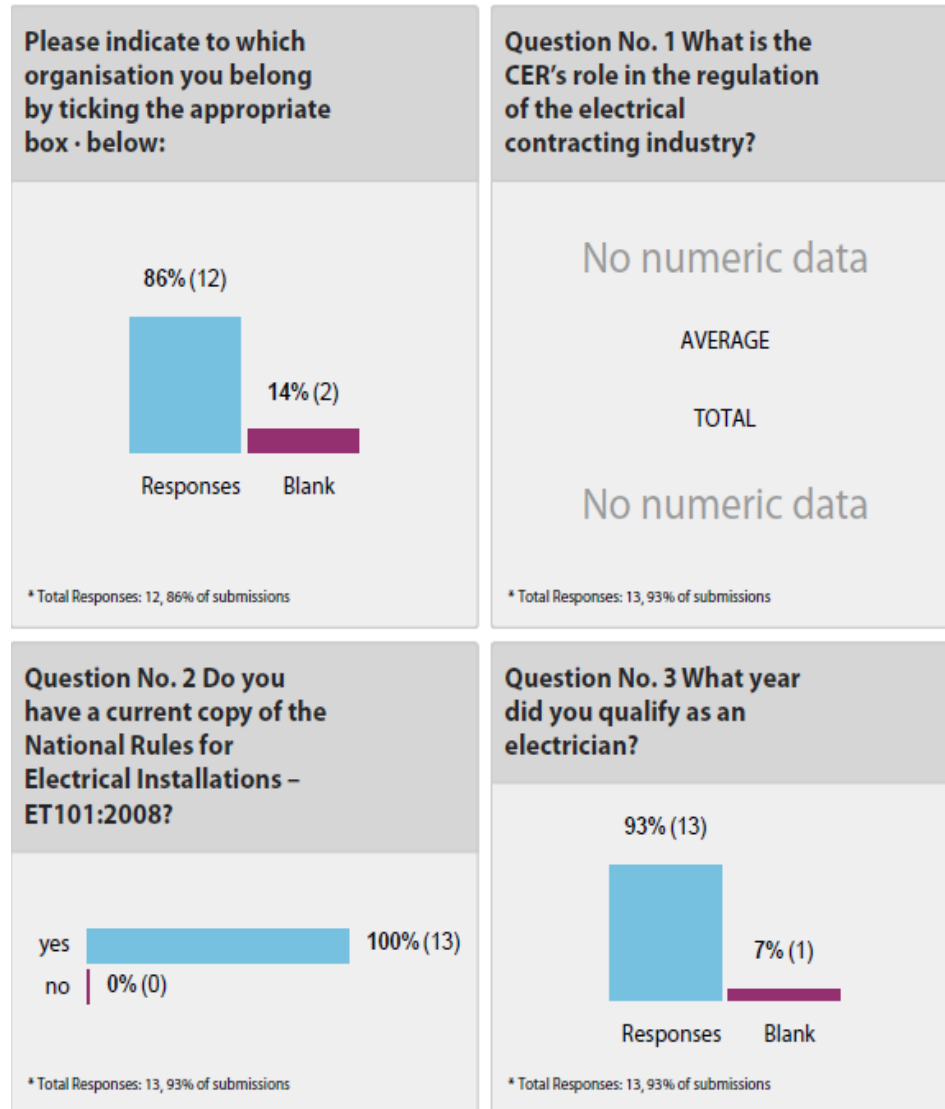

Question No. 4 What qualifications do you possess? Please select the appropriate box below:

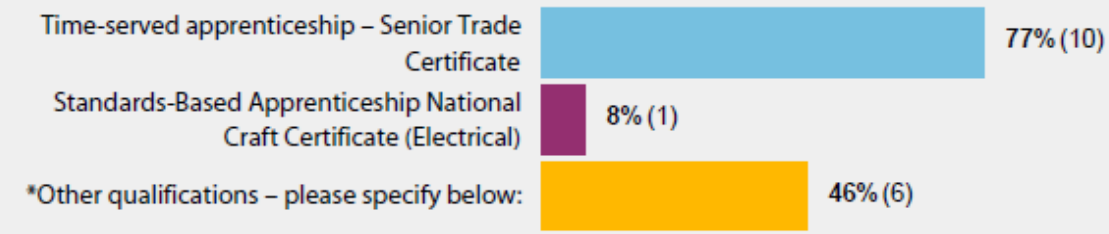

* Total Responses: 13, 93% of submissions

Other qualification(s):

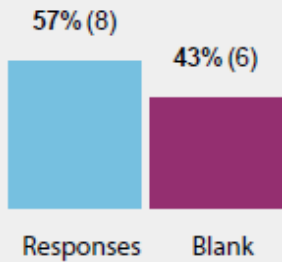

* Total Responses: 8, 57% of submissions

Question No. 5 How long are you a Registered Electrical Contractor? Please select the appropriate box below:

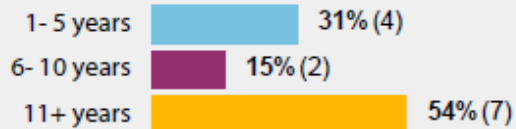

* Total Responses: 13, 93% of submissions

Question No. 6 Please indicate the number of completion certificates completed in the following years:

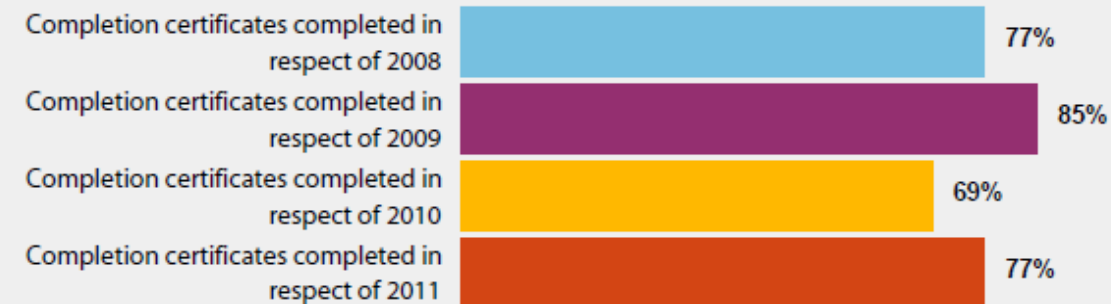

* Total Responses: 13, 93% of submissions

Question No. 4 What qualifications do you possess? Please select the appropriate box below:

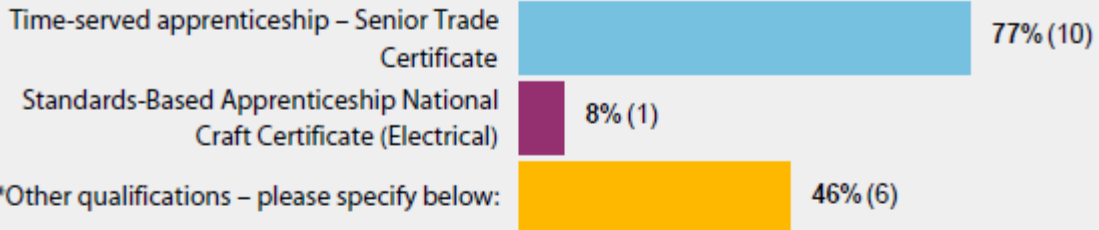

* Total Responses: 13, 93% of submissions

Other qualification(s):

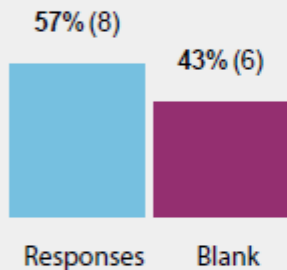

* Total Responses: 8, 57% of submissions

Question No. 5 How long are you a Registered Electrical Contractor? Please select the appropriate box below:

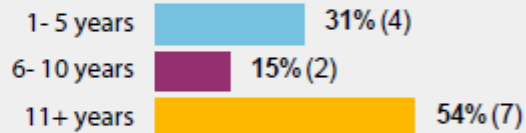

* Total Responses: 13, 93% of submissions

Question No. 6 Please indicate the number of completion certificates completed in the following years:

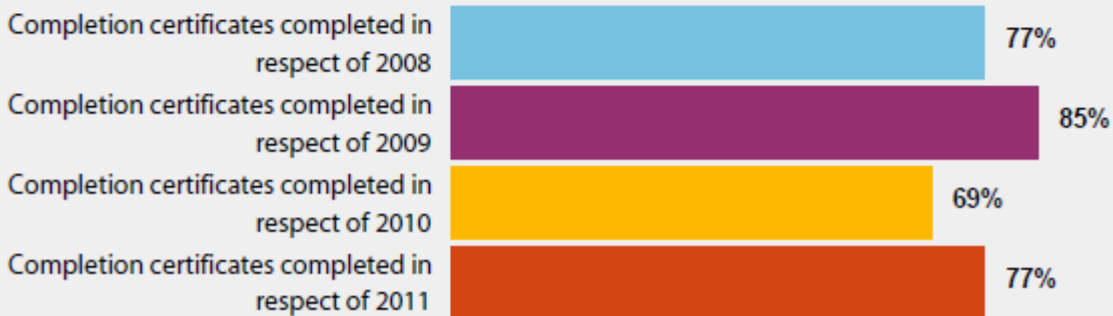

* Total Responses: 13, 93% of submissions

Question No. 7 Are you a qualified certifier of electrical installations?



* Total Responses: 12, 86% of submissions

Question No. 8 If yes, please indicate the number of years by ticking the appropriate box below:

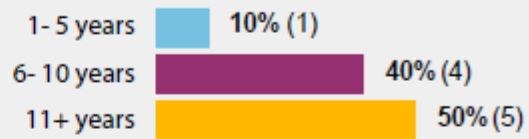

* Total Responses: 10, 71% of submissions

Question No. 9 When did you last attend a CPD course in up-dating your electrical Knowledge and skills? please select the appropriate box below?

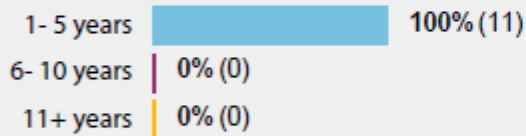

* Total Responses: 11, 79% of submissions

Question No. 10 Are you aware of the following documents in respect of electricity? Please select the appropriate box below:

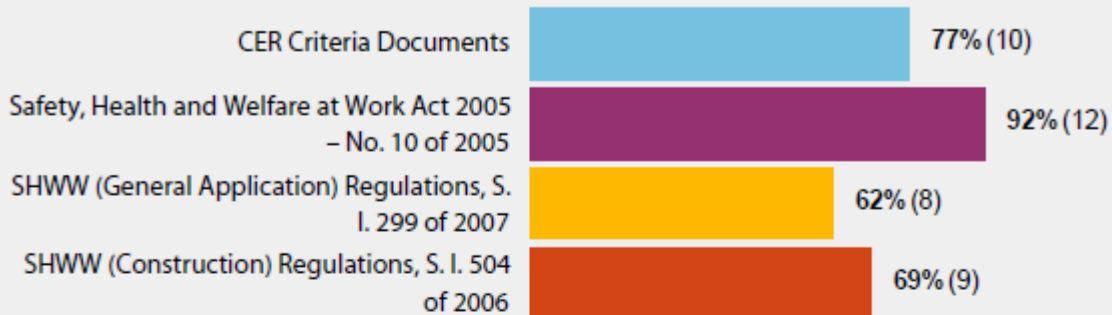

* Total Responses: 13, 93% of submissions

Question No. 11 Have you received training in the procedures to be adapted in the event of an electrical accident as outlined below? Please select the appropriate box:

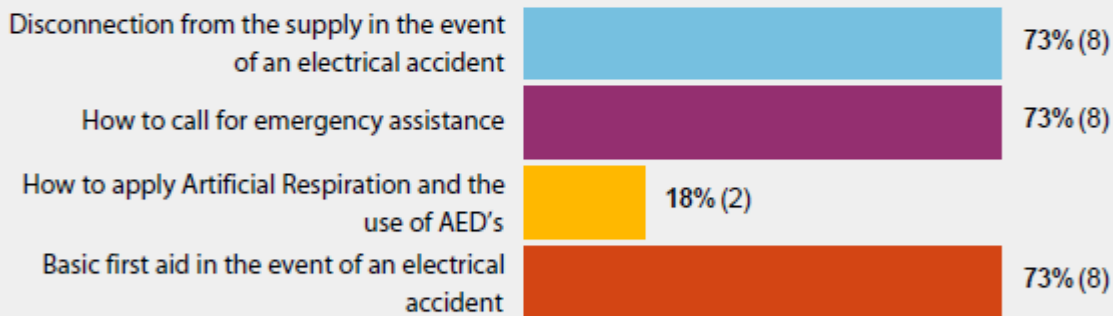

* Total Responses: 11, 79% of submissions

Question No. 12 Have you received accredited training in Potentially Explosive Atmospheres?

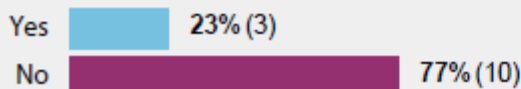

* Total Responses: 13, 93% of submissions

Question No. 13 If the answer to Q11 is yes, please indicate the appropriate level of training by ticking the appropriate box below:

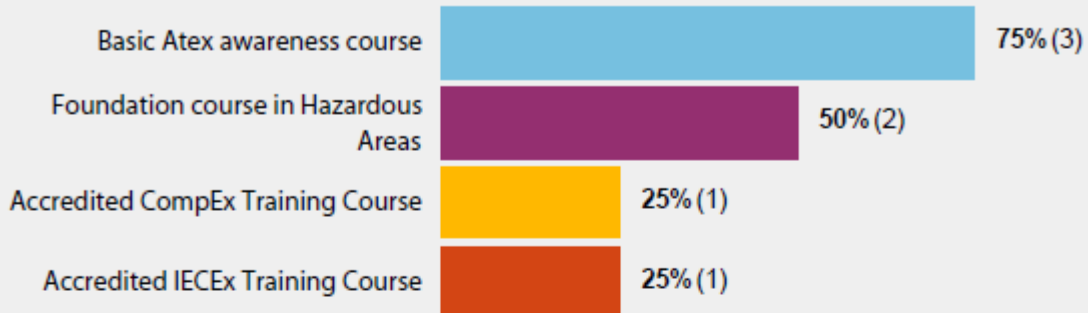

* Total Responses: 4, 29% of submissions

Question No. 14 Are you aware of your electrical safety responsibility? In respect of the following please select the appropriate box below?

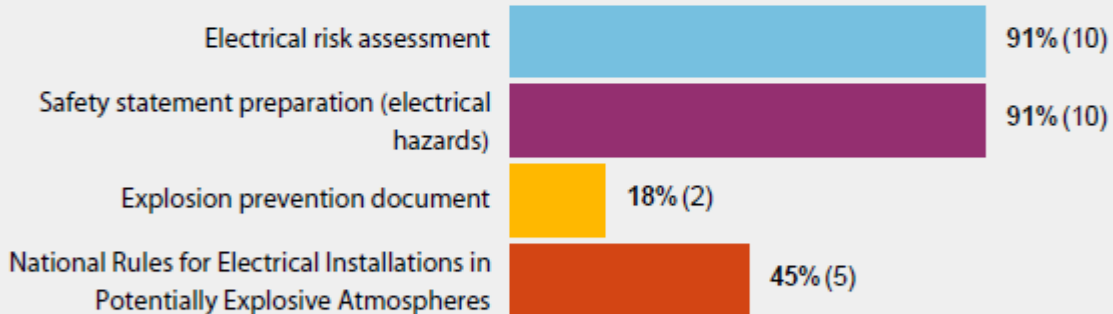

* Total Responses: 11, 79% of submissions

Question No. 15 Do you have a current copy of the National Rules for Electrical Installations in Potentially Explosive Atmospheres – ET105:2011?



* Total Responses: 12, 86% of submissions

Question No. 16 Do you believe that you are qualified to carry out work in Hazardous Areas or in Potentially Explosive Atmospheres with the need for further accredited training?

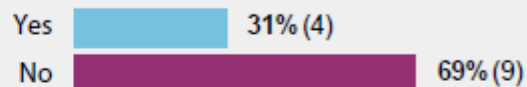

* Total Responses: 13, 93% of submissions

Question No. 21 What changes would you like to see in respect of the training and assessment of qualified certifier's in respect of the Inspection, Testing, Verification and Certification of electrical installations in the Republic of Ireland?

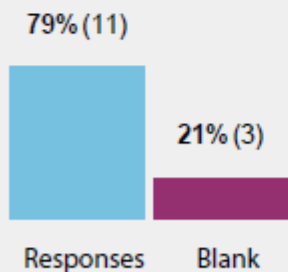

* Total Responses: 11, 79% of submissions

Question No.17 What is your opinion of the existing quality of the Inspection, Testing, Verification and Certification of electrical installations in the Republic of Ireland?

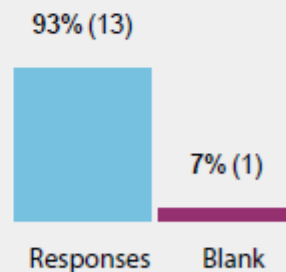

* Total Responses: 13, 93% of submissions

Question No. 18 In your own opinion, is the activity in respect of the Inspection, Testing, Verification and Certification of electrical installations in the Republic of Ireland of good quality?

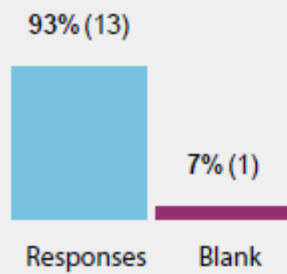

* Total Responses: 13, 93% of submissions

Question No. 19 Is the activity in respect of the Inspection, Testing, Verification and Certification of electrical installations in the Republic of Ireland carried out in a credible manner?

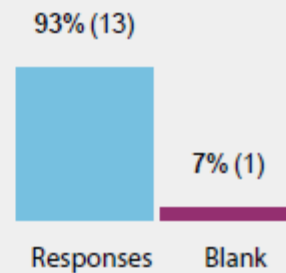

* Total Responses: 13, 93% of submissions

Question No. 20 Is the training and assessment of qualified certifier's in respect of the Inspection, Testing, Verification and Certification of electrical installations in the Republic of Ireland of good quality and credible?

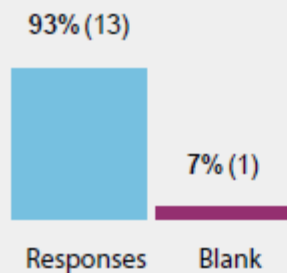

* Total Responses: 13, 93% of submissions

Question No. 22 In relation to the frequency of training courses for qualified certifier's do you feel that a 3-year cycle is appropriate?

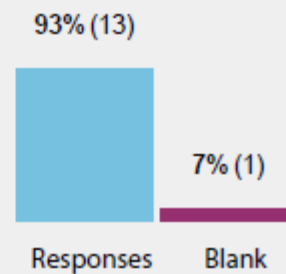

* Total Responses: 13, 93% of submissions

Appendix C

Contents of Appendix

Reference Address

Electro-Technical Council of Ireland Ltd,

ETCI Offices, Unit H12,

Centrepoint Business Park,

Oak Road, Dublin 12, Ireland

Tel :+353-1-4290088

Fax :+353-1-4290090

Email : info@etci.ie

Appendix D

Photographs Samples



