



2004

Modelling a Mechatronic System using "Matlab/Simulink" and "Dyanst"

Paul Dillon

Institute of Technology Tallaght, Tallaght, Dublin., Paul.Dillon@it-tallaght.ie

Follow this and additional works at: <https://arrow.tudublin.ie/itbj>

 Part of the [Computer Engineering Commons](#)

Recommended Citation

Dillon, Paul (2004) "Modelling a Mechatronic System using "Matlab/Simulink" and "Dyanst"," *The ITB Journal*: Vol. 5: Iss. 1, Article 10.

doi:10.21427/D7FX76

Available at: <https://arrow.tudublin.ie/itbj/vol5/iss1/10>

This Article is brought to you for free and open access by the Journals Published Through Arrow at ARROW@TU Dublin. It has been accepted for inclusion in The ITB Journal by an authorized administrator of ARROW@TU Dublin. For more information, please contact yvonne.desmond@tudublin.ie, arrow.admin@tudublin.ie, brian.widdis@tudublin.ie.



This work is licensed under a [Creative Commons Attribution-Noncommercial-Share Alike 3.0 License](#)



Modelling a Mechatronic System using “Matlab/Simulink” and “Dyanst”

Paul Dillon

Institute of Technology Tallaght, Tallaght, Dublin.

Paul.Dillon@it-tallaght.ie

Abstract

This paper presents the process of modelling a mechatronic system using two modelling methods. One the well known Matlab/Simulation package the other, Dynast, uses a novel energy based approach. The system modelled is a single axis positioning system driven via an armature controlled DC motor. The model consists of the main items in the system; pulse width modulated amplifier, DC motor, pulley and belt drive, and ball screw thread. Effects of inertia of parts and also frictional effects are also accounted for in the models. The problems of combing different disciplines within each method are shown. Simulation results are presented from the two methods. Dynast was found to have significant advantages over Matlab.

Introduction

Computer simulation has reached a certain maturity with a wide range of software packages available to simulate different disciplines e.g. pSpice in electrical electronics, Matlab-Simulink (Mathworks 2004) for control systems. There still remains the problem of integrating different engineering disciplines within one software package. Such a package would have distinct advantages for the technician or engineer who works with Mechatronic Systems as it would negate any transfer of data from separate simulation packages or having to learn the process of modelling within different packages. Also possibility of using the computer as a tool to formulate the equations underlying systems is becoming more wide spread with “Dynast” (Dynast 2004) and “Mathworks-Power Systems Blockset” (Mathworks 2004), being just two examples amongst others, (Virtual Action Group 2004, Job van Amerongen et al 2003). By investigating two separate approaches to modelling of a mechatronic system, and comparing the process and results achieved in each, a designer would appreciate any differences and advantages one system has over the other.

Mechatronic System

Mechatronics has been defined as the “synergetic integration of physical systems with information technology and complex decision making in the design, manufacture and operation of industrial processes and products”, (Tomizuka 2002).

In this paper we are concerned with the modelling, simulation and operation of an industrial process namely a positioning system in a single axis, that would be typical as found in

computer numerical control (CNC) machines. The system consists of single axis drive based on a linear ball screw, driven by an armature controlled DC motor supplied by a “Servopack”, using velocity feedback, therefore incorporating many aspects of a mechatronic system. The schematic layout of the system is given Figure 1 while a photograph of the pulley end is shown in Figure 2. The table mass consists of a plate, which is mounted on the ball screw nut. The plate also is supported on two slide bearings. The ball screw nut is driven via the screw thread, by a large pulley, which in turn is driven via a toothed belt from a small pulley, mounted on the motor shaft. The motor is slung underneath the support table, thus allowing for tensioning of the belt by the weight of the motor. The motor has an integral tachogenerator and encoder for use as velocity feedback and position control in a digital controlled system respectively. The control box consists of the Yaskawa “Servopack”, main power supply and protection circuits. The physical systems that will be considered are the “Servopack”, the DC Armature Controlled Motor, the pulley and belt drive, the linear ball screw and the mass of the table, the position of which is the end measured variable.

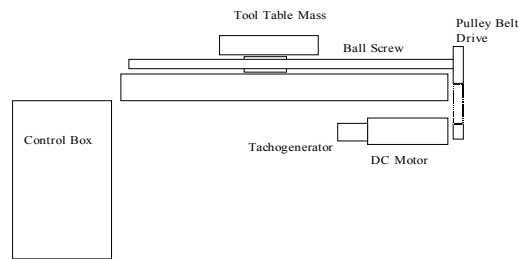

Figure 1 Schematic Layout

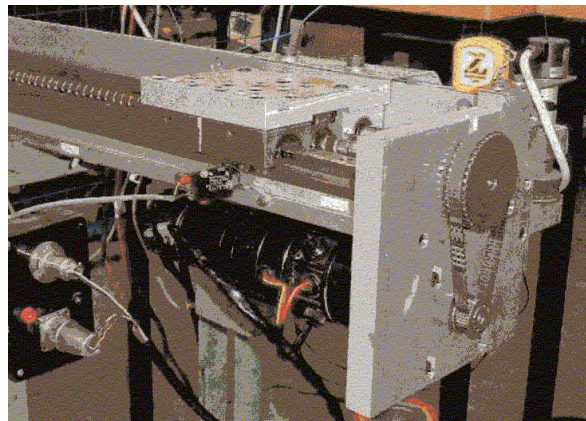

Figure 2 Pulley end of the Positioning System

Motor

The motor is a Yaskawa DC motor; the complete specifications are given in the motor technical bulletin (Yaskawa Electric Miniertia 1985). In order to understand and simulate the motor, the process followed would be to start with a sketch of the schematic arrangement of the motor main parts, as in Figure 3. Then work towards a mathematical model of the system in as much

detail as possible. The model here neglects higher order effects such as commutator contact resistance and windage effects. It would be usual to use differential equations for the relationships and then process these using Laplace Transforms.

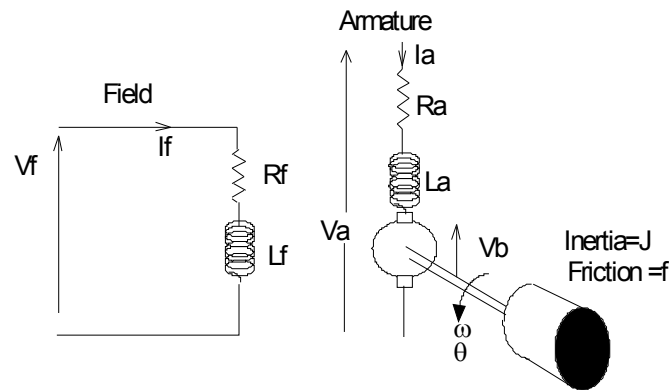

Figure 3 Schematic of a DC Motor (Dorf 1989)

One such model derived is as follows

$$G(s) = \frac{\omega(s)}{V_a(s)} = \frac{K_m}{(R_a + L_a s)(Js + f) + K_b K_m} \text{ Eq. 1 (Dorf 1989)}$$

The transfer function expresses the output $\omega(s)$ as a function of the input armature voltage $V_a(s)$ and the transfer function consisting of motor parameters. The values of the motor parameters as required for Eq. 1 are sourced from the motor specification sheet (Yaskawa 1985). $K_m=0.119$ [NmA⁻¹], $R_a=0.41$ [Ω], $J_M=0.000168$ [kgm²], $L_a=0.0006$ [H], $f=0.0000253$ [Nm (rad/sec)⁻¹], $K_b=0.0124$ [V/rpm]

Note the units used are inconsistent (but typically expressed in such a manner) and would have to be altered for use in a modelling package.

Servopack (Yaskawa Electric DC Servomotor Controllers 1987)

The Servopack allows the motor to develop approximately 190W and operate with a maximum speed of 3000rpm either in forward or reverse mode. The electronic controls supplied with the unit include over travel protection and a proportional and integral (PI) control of speed, based on a tachogenerator feedback signal from the DC motor. Separate to the actual Servopack, are a line filter, mains transformer, and thermal relay. The schematic of the circuit within the Servopack is shown in Figure 4.

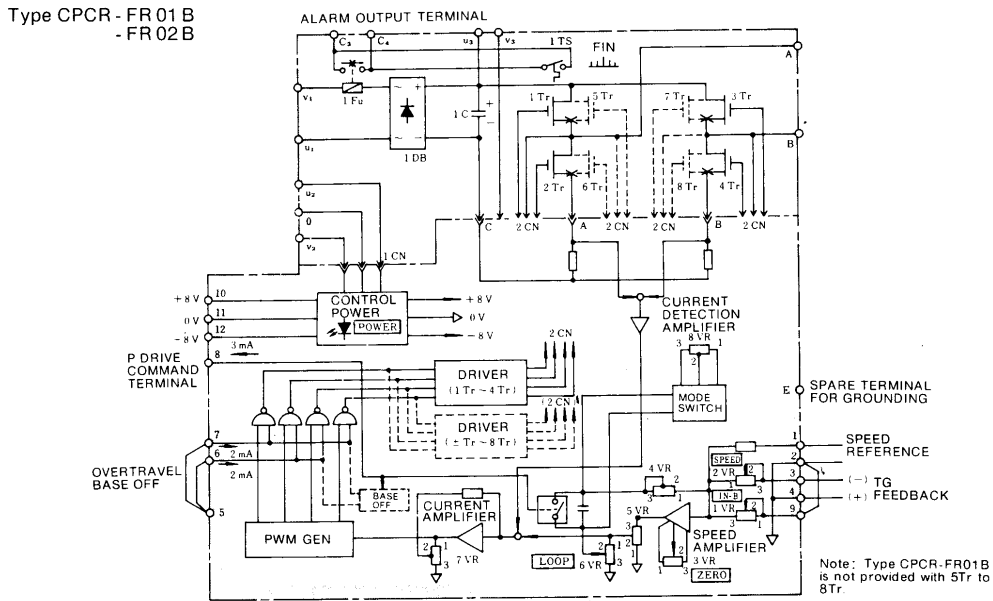

Figure 4 Schematic of Internal Connections of Yaskawa Servopack CPCR-FR02B (Yaskawa 1987)

A designer would start with a circuit design and work on sizing the parts for the application, possibly using a different software package. At the time that this work was carried out (Brehens 1997, Price 2001) access was kept to Matlab/ Simulink which had no direct way of modelling such an electronic circuit within the modelling package. As can be seen from the schematic, the main circuit consists of a H-Bridge circuit based on power FETs, which are driven by a pulse width modulated (PWM) signal. The schematic giving qualitative but not quantitative information, part values and other circuit information could be obtained by back engineering the unit. For this reason the behaviour of the circuit was only considered.

To obtain a system model, it was therefore decided to take a decision to assume that the dynamic behaviour of the PWM drive circuit was faster than that of the mechanical motor and so a simple look up table was produced mimicking the voltage output of the drive circuit. This look up table was arrived at by testing the circuit to derive the control relationship between the inputs, which were a voltage signal representing a desired speed, a feedback voltage from the tachogenerator and the output drive voltage which was pulse width modulated Figure 5. The values of the potentiometer were varied in order to look at the motor output voltage. The test was conducted with a 7V feedback signal, from the simulated tachogenerator.

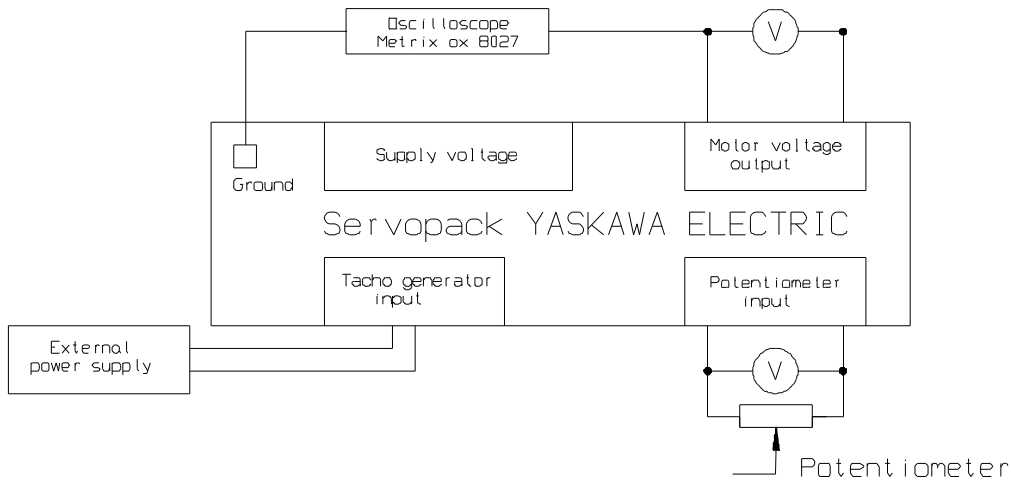

Figure 5 Test Setup for deriving the Control and Drive Relationships for Servopack. (Brehrens 1997)

The results, in Figure 6, showed that the drive voltage has a narrow proportional band based on the difference between the desired input voltage and the feedback voltage and also there is a proportional relationship between the desired input voltage and feedback voltage from the tachogenerator. The tachogenerator voltage being 3.5 times that of the input voltage. This plot is representative for the motor output voltage behaviour for the other tests at 14V and 20, merely showing that the curve is moved along the input voltage axis.

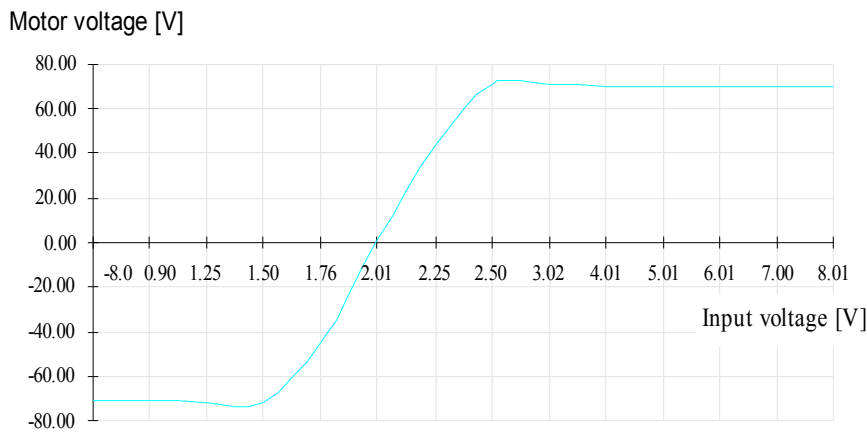

Figure 6: Control behaviour of the Servopack

Transmission System

The transmission system consists of a pulley drive, which has a ratio of 2.892. The belt is toothed in order to minimise the possibility of backlash. The pulleys, ball screw and tool table mass are considered to have a certain reflected inertia to the motor. The calculation of which is covered by Gross 1983. The total reflected inertia excluding the motor inertia J_{xt} can be then calculated by the following

$$J_{ext} = J_{sp} + \frac{J_{lp} + J_{bs} + J_{lin}}{i^2} \quad \text{Eq 2}$$

$$J_{sp} = \text{Inertia of small pulley wheel} = 7.482 \times 10^{-6} \text{ kgm}^2$$

$$J_{lp} = \text{Inertia of large pulley wheel} = 6.7991 \times 10^{-4} \text{ kgm}^2$$

$$J_{bs} = \text{Inertia of ballscrew} = 3.2 \times 10^{-5} \text{ kgm}^2$$

$$J_{lin} = \text{Inertia of the driven linear element} = 5.75 \times 10^{-6} \text{ kgm}^2$$

$$i = \text{Pulley ratio} = 2.892$$

$$J_{ext} = 9.329 \times 10^{-5} \text{ kgm}^2$$

The motor inertia as given by Yaskawa (Yaskawa 1985) is $J_M=0.000168$ [kgm²]. The motor is directly attached to the small pulley wheel.

The total inertia reflected back to the motor can then be included in the block diagram of Figure 3 by

$$J = J_m + J_{ext} \quad \text{Eq 3}$$

$$J = 1.68 \times 10^{-4} + 9.329 \times 10^{-5} \text{ kgm}^2$$

$$J = 2.610 \times 10^{-4} \text{ kgm}^2$$

Apart from the inertia loading on the motor, we have to consider the frictional load exerted by the transmission elements. Friction is generated in a number of locations, friction in slide guides, frictional losses in the feed screw bearing, frictional losses in the feed screw nut and finally pulley and belt drive losses.

The influences of the friction torque and losses from the feed screw drive can be described as the sum of T_f [Nm] the friction torques. We obtain the friction torques reflected on the motor by equation 4.

$$\sum T_f = \frac{\left(\frac{T_{fsg}}{\eta_{fsn}} \right) + T_{fsb}}{\eta_p \cdot i} \quad \text{Eq. 4. (Gross 1983)}$$

Where, T_{fsg} = friction torque in the slide guides

η_{fsn} = efficiency of feed screw nut

η_p = efficiency of pulley drive

T_{fsb} = friction torque of feed screw bearing

i = ratio of pulley drive

Friction in slide guides. Gross (1983) states that the friction in the slide guides can be taken as

$$T_{fsg} = \mu_f \cdot \frac{P_{bs}}{2\pi} \left[(m_T + m_{wp}) \cdot g + F_c \right] \quad \text{Eq. 5 (Gross 1983)}$$

Where, μ_f = the speed dependent friction factor

m_t = mass of tool table [kg]

- m_{wp} = mass of workpiece [kg], which is zero because it does not exist
- p_{bs} = pitch of ball screw [m]
- g = 9.81[ms⁻²], gravitational acceleration
- F_c = force of cutting [N], which is not present

The speed dependent friction factor μ_f , of the actual friction guide, is difficult to decide on. Therefore we assume a mean value a factor between 0.05 and 0.1.

$$T_{fsg} = 0.075 \cdot \frac{0.01}{2\pi} \cdot 2.268 \cdot 9.81 = 2.656 \cdot 10^{-3} [Nm]$$

Frictional losses in the feed screw bearing are again accounted by referring to Gross 1983, page 127. The feed screw is supported with two ball thrust bearings. If there was a force working against the tool table, in the direction of the bearings, the load on the bearings become larger, due to the force. This load causes a greater friction in the bearings and therefore a friction torque which has an effect on the motor. According to the INA company this friction torque is approximately

$$T_{fsb} = \mu_{sb} \cdot 0.5 \cdot d_m \cdot F_{al} \quad \text{Eq. 6 (Gross 1983)}$$

- where, μ_{sb} = speed dependent frictional factor of the feed screw bearing
- d_m = mean value of the bearing diameter [m]
- F_{al} = axial feed screw load [N]

For the speed dependent frictional factor of the feed bearings μ_{sb} a mean value can be taken and is chosen to be between 0.003 and 0.005, according to Gross, page 228. The mean value of the diameter is 0.019[m]. The axial feed screw load is described, according to Gross, as a machining force. For the modelled system no machining force exists and therefore the equation would reduce to zero, the force F_{al} is not present. Therefore we assume a force caused by *Newton's law of motion*. We get

$$F_{al} = m_t a_t \quad \text{Eq. 7}$$

- where, m_t = mass of tool table [kg]
- a_t = acceleration of table [ms⁻²]

If we substitute the above equation for F_{al} into the T_{fsb} equation we obtain the friction torque of the feed screw bearings T_{fsb} [Nm] as follows

$$T_{fsb} = 8.618 \times 10^{-5} \cdot a_t [Nm] \quad \text{Eq. 8}$$

Taking the frictional losses in the feed screw nut next. The feed screw nut in the original model, is a ball screw nut, these type of nuts are commonly used, because less friction results.

Nevertheless, we will consider the efficiency of the ball screw nut. This coefficient η_{fsn} can be calculated approximately as below

$$\eta_{fsn} \approx \frac{1}{1 + 0.02 \cdot \frac{d_{bs}}{p_{bs}}} \quad \text{Eq. 9 (Gross 1983)}$$

where, d_{fs} = diameter of ball screw [m]
 p_{bs} = pitch of the ball screw [m]

The pitch p_{bs} is given with 0.01[m]. The ball screw has a diameter of 0.015 [m]. By applying eq. 9 we get

$$\eta_{fsn} \approx \frac{1}{1 + 0.02 \cdot \frac{0.015}{0.01}} \approx 0.971$$

Finally taking pulley and belt drive losses, the efficiency of the belt and pulley system can be taken to be 95 to 98% under correct operating conditions.

Applying Equation 4 we obtain the sum of the friction torques T_f [Nm] reflected on the motor, shown below.

$$\sum T_f = \frac{0.00273532 + 0.00008162 \cdot a_t}{2.83416} \quad \text{Eq. 10}$$

Modelling Packages

Matlab Simulink

If we now consider the problem of modelling the complete system within the chosen software package. Taking the Matlab/Simulink system first, the complete system is shown in Figure 7.

A number of submodels are shown within the block diagram. The motor submodel is shown in Figure 9. This is a direct application of the block diagram Figure 8, resulting from the transfer function for the DC motor, equation 3.

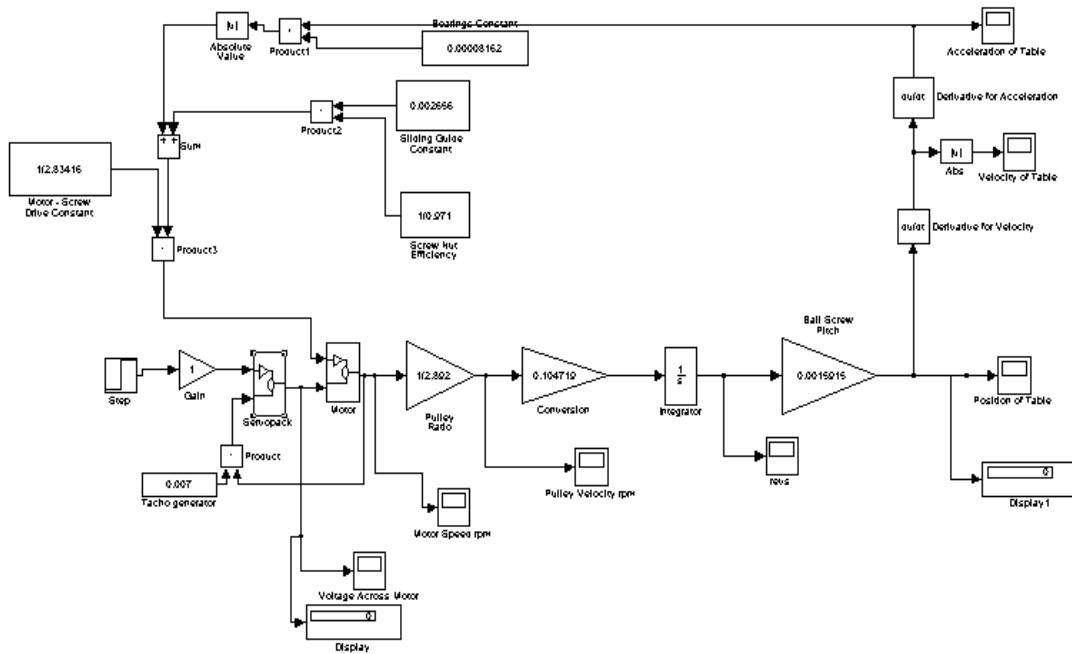

Figure 7 Complete Matlab Simulink Model of the Motor Pulley Screw Drive

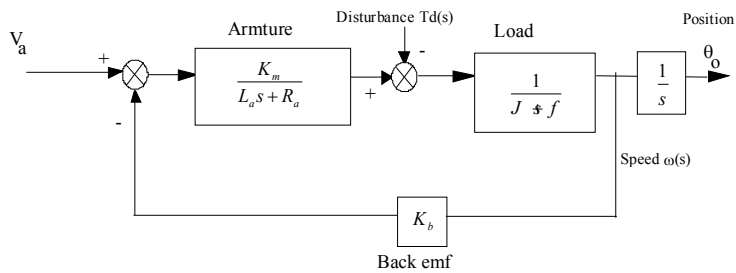

Figure 8 Block Diagram of Motor (Dorf 1989)

The block diagram allows for the influence of an external disturbance torque $T_d(s)$ to be included, which in our case will simulate the frictional torques. By substituting in the motor parameters the resulting simulation block diagram is shown in Figure 9.

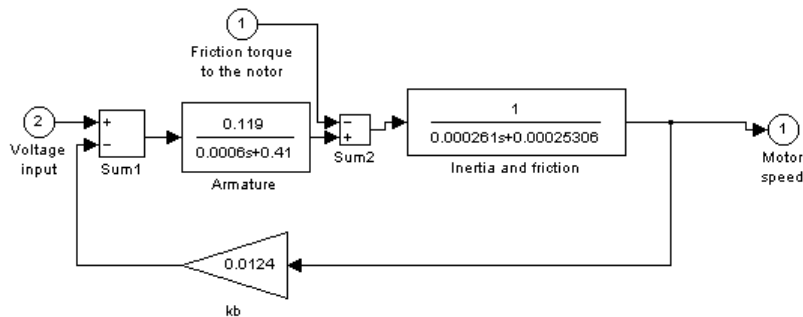

Figure 9 Simulink Diagram for DC Motor Transfer Function

The motor “Voltage Input” point, derives from the model of the Servopack which is set up as a look up table. Figure 10. The “Friction torque to the motor” point depends on from the acceleration of the tool table mass. This is accounted for in the simulation by taking a signal of the position of the table and completing a double derivative to generate an acceleration signal. This is then used to implement equation 10 as derived. The other submodel is the servopack. Figure 10. This is quite simple, the two inputs are the desired motor speed” and the feedback voltage from the tachogenerator. These are summed to provide an input to the look up table which generates a voltage output, such as given in Figure 6.

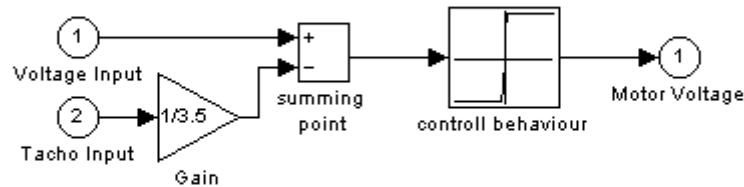

Figure 10 Simulink Block Diagram representing Servopack operation.

Dynast (Dynast 2004)

To contrast the above process. Dynast (Dynast 2004) uses a novel method of modelling, the concept of “multipole” modeling. This allows the integration of different engineering disciplines within the one modelling package. Multipole modelling is similar to the nodal analysis approach in electrical systems. The basic procedure is to break up the proposed model into disjointed subsystems. Similar to forming free body diagrams in mechanics. The disjointed subsystem can then be analysed under the assumptions that the mutual energy interactions between subsystems take place at a limited number sites such as electrical connections, pipe connections (fluid systems), or mechanical contacts. The energy flow through each contact point can be expressed by a product of two complementary power variables such as voltage and current, force and velocity. The energy entry point is modeled as a pole associated with a pair of power variables. Individual physical elements such as an electrical resistor can then be expressed as a two pole model, with the power consumed being governed by

$$P_e(t) = i_e(t) \cdot v_e(t)$$

where i_e is the through variable flowing through the element and v_e is the across variable between the element poles.

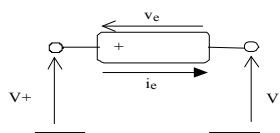

Figure 11 Variables associated with a generic physical element (Dynast 2004, Mann 1999)

Once a multipole model for an element has been developed, it can be contained within a library for further use, allowing the user to build up a resource of increasing complexity and sophistication. Simulation models of real systems can then be built by including these multipoles within a complete diagram. The user can start with a simple model based on simple elements then add in more elements to represent behaviours of higher order or smaller effects. Figure 12 shows just one variation of multipole diagram as crude representation of the mechatronic system. This includes the PWM circuit, a complex multipole model of the DC motor, the multipole model of the transmission system. Included is a PID block with the I and D turned off. This block gives feedback control of the PWM circuit. As can be seen the Dynast representation allows the use of symbols that schematically look like the physical element concerned. The PWM circuit is built up from resistors, capacitors and op amps. The Transmission section is constructed of multipole elements representing inertias, and damping elements for rotational and linear motions. The transmission structure also has transformer elements to represent the pulley and belt ratio and the transformation from rotary motion to linear translation motion.

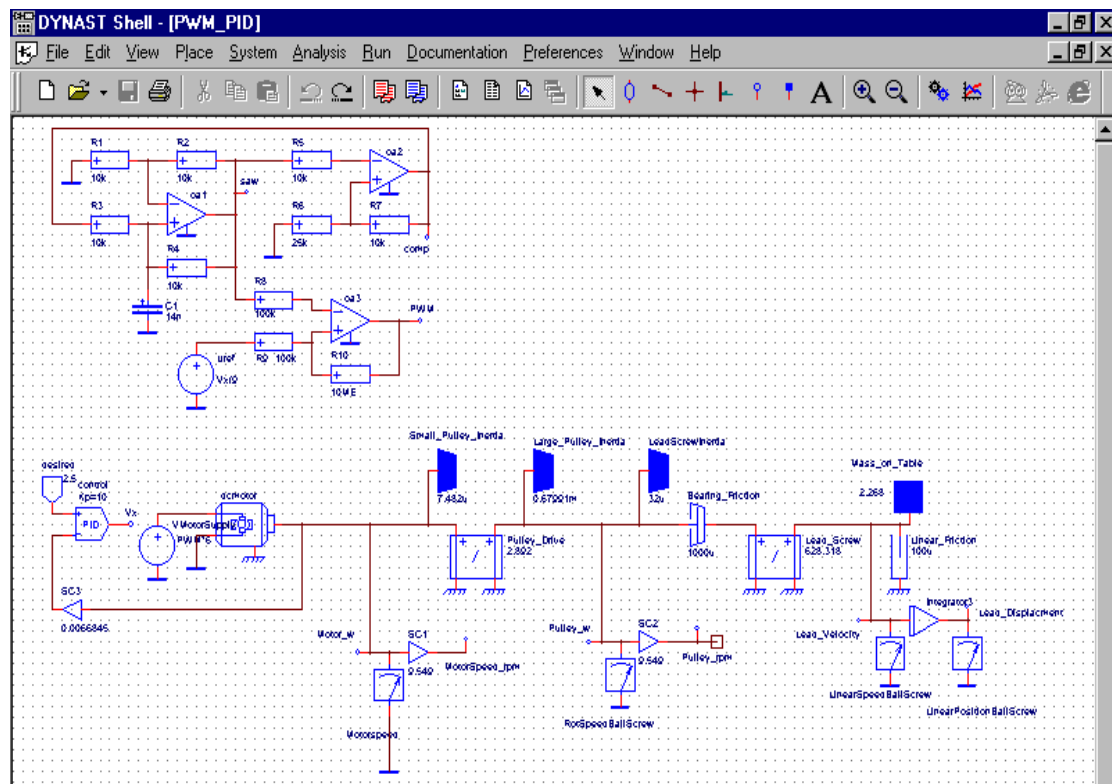

Figure 12 Dynast Representation of the System Including PWM Circuit, DC motor and Transmission System, along with Proportional Control of Speed.

Results

Figures 13 and 14 show the results for simulations run using the Matlab/Simulink model and the Dynast model, for a time of 0.5 seconds. The aim being to compare the resulting calculations for the motor speed (rpm) and the lead screw displacement (m).

We are interested in the lead displacement output in this paper for comparison. (Other parameters within Dynast would be available such as the PWM voltage output wave). From Figure 13 one can see that the simulations compare well in the end result. The slight difference in lead displacement is due to the difference in motor speed as shown in Figure 14. One can see that the Matlab model achieves a steady state speed of 1200rpm by 0.02 seconds while the Dynast model responds faster and has a higher final speed. This difference is due to tuning of the parameters on the PWM and the proportional control values. By re-tuning of values and investigation of the PWM circuit as well as incorporation of an H Bridge circuits it is hoped to approach a closer model to the real system. Variations on circuits have not been shown here.

Future Work and Conclusion

Further work will have to be completed on the design of the PWM circuit to allow for direct application of the velocity feedback on the pulse width, with an electronic circuit rather than a block diagram. Consideration will be given to modelling a commercial PWM driver such as the HIP4081 or the UC3637 and changing the BJTs to MOSFETs in the H Bridge. Considering the approach used for each model, derivations of physical values of mechanical parts were common to both, although Dynast applied them singly in direct relation to where the inertias were in the real system and also the frictional effects are handled in the same manner. Also Dynast was able to bring both the electronic and mechanical aspects in the one environment, the PWM circuit, the multipole model of the DC motor, the mechanical transmission system. A designer of electronic circuits would no doubt make more appropriate circuit for the PWM than the author. The Matlab model was assembled from equations representing the behaviour of the system. Dynast has some advantages over Matlab, one being able to incorporate the different disciplines the most obvious. The modelling method Dynast uses of directly generating the model rather than generating equations is also significant. Dynast can also be used as a toolbox for Matlab for modelling and control (Mann et al 2000). Dynast is freely available to use across the Internet thereby making it useful from a teaching/student perspective. A course on Modelling and Control with toolboxes for designing "Virtual Experiments" is currently being developed for support of teaching in the area using Dynast, (DynLAB 2004). Investigations of other multidiscipline simulation tools such as 20 Sim (van Amerongen et al 2003), which uses Bond Graphs (Karnopp 2000), along with extensions to the Matlab toolbox/blockset will be carried out, for future support of Mechatronic courses.

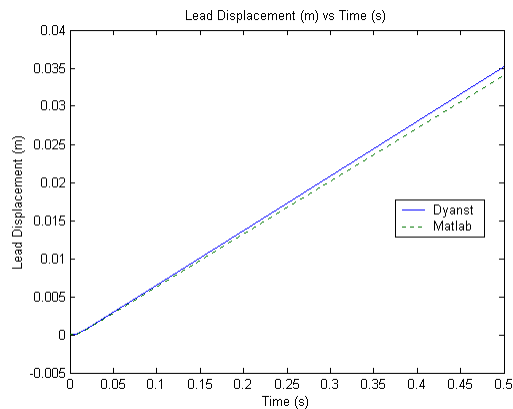

Figure 13 Lead Displacement (m) V's Time (s)

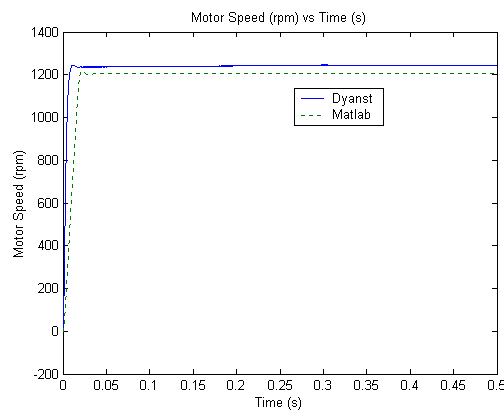

Figure 14 Motor Speed (rpm) V's Time (s)

Acknowledgements

The author would like to gratefully acknowledge the support of the Leonardo da Vinci Program of the European Union for the “DynLAB” project.

References

- Brehrens, M.**, *Simulation and Construction of a Machine Tool Feed Drive*, 1997, Project Thesis, IT Tallaght.
- Dorf R. C.**, *Modern Control Systems*, 5th Edition 1989 pp 49 to52
- Dynast**, Website for Modelling System <http://virtual.cvut.cz/dyn/> 2004
- DynLAB**, Website of the DynLAB the Leonardo da Vinci Vocational Training Programme Pilot Project at <http://icosym.cvut.cz/dynlab/> 2004
- Gross, H.**, *Electrical Feed Drives for Machine Tools*, John Wiley and Sons 1983.
- Karnopp D., Margolis D., Rosenberg R.**, *System Dynamics*, Wiley Interscience, 2000
- Mann H.**, *Support for Efficient Modelling of Multidisciplinary Systems*, Proceedings of the ASME Vol. 67. Nashville, 1999.
- Mann H., M. Ševčenko, J. Pavlík.** *Dynast – modeling toolbox for Matlab formulating equations automatically* Proc. 8th Conf. on Matlab 2000, Prague 2000, pp. 416-420.
- Mathworks** <http://mathworks.com/> 2004
- Price, A.**, *Instrumentation of a Motor Drive Rig and Comparison with a Simulink*, 2001, Project Thesis Degree, IT Tallaght
- Tomizuka, Masayoshi**, *Mechatronics: from the 20th to the 21st Century*, Control Engineering Practice 10 (2002) pp877-886.

van Amerongen Job, Breedveld Peter, *Modelling of Physical Systems for the design and Control of mechatronic systems*, Annual Reviews in Control 27, 2003 pp87-117

Virtual Action Group for Multidisciplinary System Simulation Technical Committee on Computer Aided Control System Design of the IEEE Control Systems Society at <http://icosym.cvut.cz/cacsd/dyn/> 2004

Yaskawa Electric DC Servomotor Controllers “Servopack™” Transistor PWM Reversible Type CPR-FR01B to FR05C TSE-C717-11G Bulletin January 1987

Yaskawa Electric Miniertia® Motor RM Series Type UGRMEM TSEC 253-10C Bulletin August 1985