

2004

Design of a Wear Test Machine for Diamond Saw Segment

D. Nulty

Department of Mechanical Engineering, Institute Technology Tallaght, Dublin 24.

J. Dwan

Department of Mechanical Engineering, Institute Technology Tallaght, Dublin 24.

Y. Blake

*Department of Mechanical Engineering, Institute Technology Tallaght, Dublin 24.*Follow this and additional works at: <https://arrow.tudublin.ie/itbj> Part of the [Civil and Environmental Engineering Commons](#)

Recommended Citation

Nulty, D.; Dwan, J.; and Blake, Y. (2004) "Design of a Wear Test Machine for Diamond Saw Segment," *The ITB Journal*. Vol. 5: Iss. 1, Article 3.

doi:10.21427/D7C45W

Available at: <https://arrow.tudublin.ie/itbj/vol5/iss1/3>

This Article is brought to you for free and open access by the Journals Published Through Arrow at ARROW@TU Dublin. It has been accepted for inclusion in The ITB Journal by an authorized administrator of ARROW@TU Dublin. For more information, please contact yvonne.desmond@tudublin.ie, arrow.admin@tudublin.ie, brian.widdis@tudublin.ie.



This work is licensed under a [Creative Commons Attribution-NonCommercial-Share Alike 3.0 License](#)

Design of a Wear Test Machine for Diamond Saw Segment

D. Nulty J. Dwan and Y. Blake

Department of Mechanical Engineering, Institute Technology Tallaght, Dublin 24.

Abstract

Diamond tools are used in a wide range of industrial areas such as construction industry, metal machining and exploration drilling. The diamond impregnated tools used in the stone and construction industry are metal matrix composites. Diamond saw blades are the most commonly used tools.

The optimum operation of diamond saw blades is determined by the cutting action of the diamond grit and the bounding of the metal matrix. However the wear behavior of the diamond saw has been less studied. Currently in the blade development, actual full blade tests often have to be conducted for optimization and the testing process is very slow and expensive to carry out. So the development of a testing machine that could reduce the blade development time would be very advantageous.

This paper describes the design and construction of a wear apparatus which simulates the wear conditions that a diamond impregnated saw blade experiences by using just a single segment. It is also our intention to present single segment wear tests on ceramic-based materials, which can be used for the testing and developing of a full blade diamond saw.

1. Introduction

Diamond tools are used in a wide variety of applications of which the most important include the drilling and sawing of rocks and concrete, grinding of glass or metals, polishing of stone. The most dramatic increase in the importance and growth of industrial diamonds have been the advent of synthetic diamonds and the use of diamond tools into the stone and construction industries [1]. Nowadays synthetic diamond holds the largest share at 90% of the industrial diamond tool market [2].

1.1 Diamond saw blades

Diamond impregnated tools consists of randomly dispersed and orientated diamond crystals in a metal matrix which bonds diamond together. As the tool cuts the matrix erodes away from the diamond. This exposes the diamond and gives the diamond crystals clearance for penetrating the material and also allows the cuttings to be flushed out. For proper operation the metal bond must wear away progressively so that new diamonds are exposed to continue the cutting action during the life of the diamond tool.

The key factors that determine the choice of matrix metal include (a) the wear resistance of the matrix; (b) the type and size of diamonds to be used and (c) the tool fabrication process.

For a particular application, currently the blade is selected by picking a stock item recommended by the tool manufacturer. However, often an off-the-shelf blade does not fully fulfill the requirements of blade life and cutting performance. At this stage, the diamond tool manufacturer has to develop a new matrix either by modifying the existing matrix or by designing a completely new matrix. Where full scale blade testing is carried out on different

types of stone or concrete materials, it can be very expensive as well as time consuming when one considers that on a typical 600 mm diameter blade there can be 40 segments. Substantial cost savings could be made if this type of testing could be carried out using single segments with different matrices and diamond combinations [3].

1.2 Design Requirements

The cutting performance of the saw blade can be related to segment wear and blade life. It is also important that a blade being capable of “free-cutting”. A “free-cutting” blade is a blade that cuts without too much difficulty. If the matrix is too soft, or excessively “free-cutting”, the blade life can be prematurely short. The opposite of “free-cutting” is a blade matrix that is too hard or has high wear resistance.

The design requirements of the machine are that it accommodates the normal range of blade diamond matrices, cutting speeds and feeds as closely as possible to that found in the field. The following are the typical test conditions which are normally encountered:

- (a) Peripheral blade speeds, ranging from 25 to 60 m/s, which are typical blade speeds used in industry.
- (b) Variable normal force applied on the saw segment.
- (c) Range of diamond concentrations, grit sizes and grades
- (d) Different matrix compositions
- (e) Range of different types of stone and concrete for testing.

2. Design analyses

The analysis initially examined the cutting action of a multi-segment blade and compared it to a single-segment ‘flywheel’ type blade. The analysis also examined the scenario of a segment-on-disc arrangement and compared it to the single-segment ‘flywheel’ and multi-segment blades. The investigation was approached from the perspective of examining the cutting action of the diamonds. The assumption was that the single-segment is identical to that of the multi-segment.

Bütner [4] developed an equation which described the cutting process that takes place in grinding wheels. These grinding wheels are similar to saw blades in that the diamond used has similar crystal shapes, and the matrix is a metal bond. Bütner proved for a grinding wheel that the ‘average area cut by each diamond, $\overline{A_{ps}}$ ’ was given by,

$$\overline{A_{sp}} = \frac{u_1}{v_1} \frac{1}{N_k} \sqrt{\frac{a_1}{D_1}} \dots\dots\dots(1)$$

where u_1 = feed rate

v_1 = blade speed (peripheral blade speed)

a_1 = depth of cut

D_1 = diameter of blade

N_k = No. of effective cutting grits per unit area

Normally though diamond impregnated sawblades are made up of segments. The spaces between each segment are called gullets. However a grinding wheel is a continuous rim which has diamond all around its circumference, but in a sawblade there is a reduction in the diamond cutting area because of these gullets. Bienert [5] modified Büttner's equation to take this into account by including a quotient ($\lambda_1 = l_2 / l_3$) which compared the length of the segment to the length of the segment plus the gullet length.

Bienert's equation for a segmented sawblade is

$$\bar{A}_p = \frac{u_1}{\lambda_1} \frac{1}{v_1 \cdot N_k} \sqrt{\frac{a_1}{D_1}} \dots\dots\dots(2)$$

According to Bienert [5] the cutting action of each individual diamond grit is the same for both the multi-segment blade and the single segment blade. The only difference is the amount of material removed, the multisegment, having more segments, will remove more than the single segment wheel. The feed rate for the single segment blade is slower to take account of the reduced cutting surface.

The proposed wear testing is a pin-on-disc type wear machine, in which the diamond impregnated segment plays the role of 'pin' and the material to be tested forms the disc. In order to compare a segmented sawblade with the proposed testing machine, the cutting action of the diamonds is examined. The test segment used here is equivalent to that used in a multi or single segment blade. Using Bienert's[5] statement that the effective cutting performance of each cutting diamond is the same, then the following equation for calculating the feed rate ' u_2 ' of the segment into the stone disc was derived for the downward feed rate of the test segment on the test machine:

$$u_2 = \frac{u_1 \cdot l_4}{\lambda_1 \cdot \pi \cdot D_2} \sqrt{\frac{a_1}{D_1}} \dots\dots\dots(3)$$

where, ' u_2 ' = axial feed rate of the segment into the stone disc,

' u_1 ' = feed rate of multisegment blade,

' l_4 ' = POD segment length,

' D_2 ' = diameter of stone track on stone disc,

- ' D_1 ' = diameter of sawblade,
- ' a_1 ' = depth of cut using multisegment blade,
- ' λ_1 ' = segment quotient of multisegment blade.

The derived above equation (3) gives the downwards feed rate for the single segment into the tone disc which is equivalent to the cutting action of a multisegment sawblade.

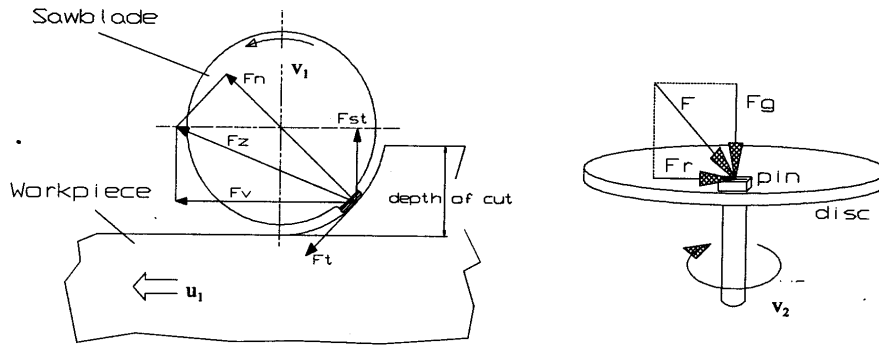

Figure 1 Single segment sawblade and pin-on-disc machine

3. Machine Design and Construction

After investigation on several of designs of pin-on-disc machines the following is the specific descriptions of the chosen design. The diameter of the stone disc was calculated from data determined from 'cutting arcs' which different sized blades would describe if cutting in a downward mode of cutting. From the initial analysis, a saw blade range was chosen from 500 mm to 850 mm in diameter. From these sawblade diameter ranges, a percentage range of depth of cut (a_1) was selected. It started at 10% of blade diameter, increasing by 5% to a maximum depth of cut of 45% of blade diameter.

From the various ranges for 'depth of cut' for each blade size, the different angles for α , the angle of engagement, were calculated. These values for the angle of engagement, α , gave the lengths (l_1) of the different cutting paths or trochoids which different blade sizes and 'depths of cut' would generate when sawing.

Translating these values for the cut path lengths (l_1) to the wear testing machine, the cut lengths ' l_1 ' are represented as half the circumference of different diameters on the disc. To separate each ' l_1 ' a slot is cut in the stone disc. From this, the diameters of the cutting tracks on the disc were calculated with each track representing twice the ' l_1 ' cut path for each depth of cut for each blade diameter combination,

The corresponding peripheral blade speeds for the different wear track diameters and the motor rpm were calculated. The motor (4 kW) had a capability of rotating from 1000- 3500 rpm through a speed inverter controller. A spreadsheet was developed which related the ‘% depth of cut’ with the peripheral blade speed. Two different blade sizes could have the same cutting track, but it would only differ by the % depth of cut in actual practice in the field.

Measurement of the input to the electric motor of a machine tool provides a convenient method of measuring the power consumed in cutting. An approximate method is given by Black et al. [6] where if the value of the power supplied when the machine is running idle is subtracted from the power reading taken under the cutting load, a reasonable estimate of the power consumed in cutting is obtained. A wattmeter is used so that the power consumed can be recorded as the different segment compositions are used and the different stone materials tested

As the cutting forces in action can be considered to be similar to those in a drilling machine, a hydraulic cylinder with a load cell to measure the vertical axial cutting force is used. It would therefore be possible to monitor the cutting action of the diamond saw segment. It is intended to measure the frictional force resulting from the cutting action of the test segment on the stone disc. Two methods were investigated, one using a load cell, the other using strain gauges. Strain gauges were chosen and are mounted on the cantilever segment holder. A multiplexer with a PC with a data acquisition card is connected to the circuit with signal capture at 1/1000 times a second. From the calculated forces resulting from the bending of the cantilever the frictional force can be measured. The final design is shown in Figure 2. A pin-on-disc type machine was designed to simulate the cutting action of the diamonds in a diamond impregnated tool.

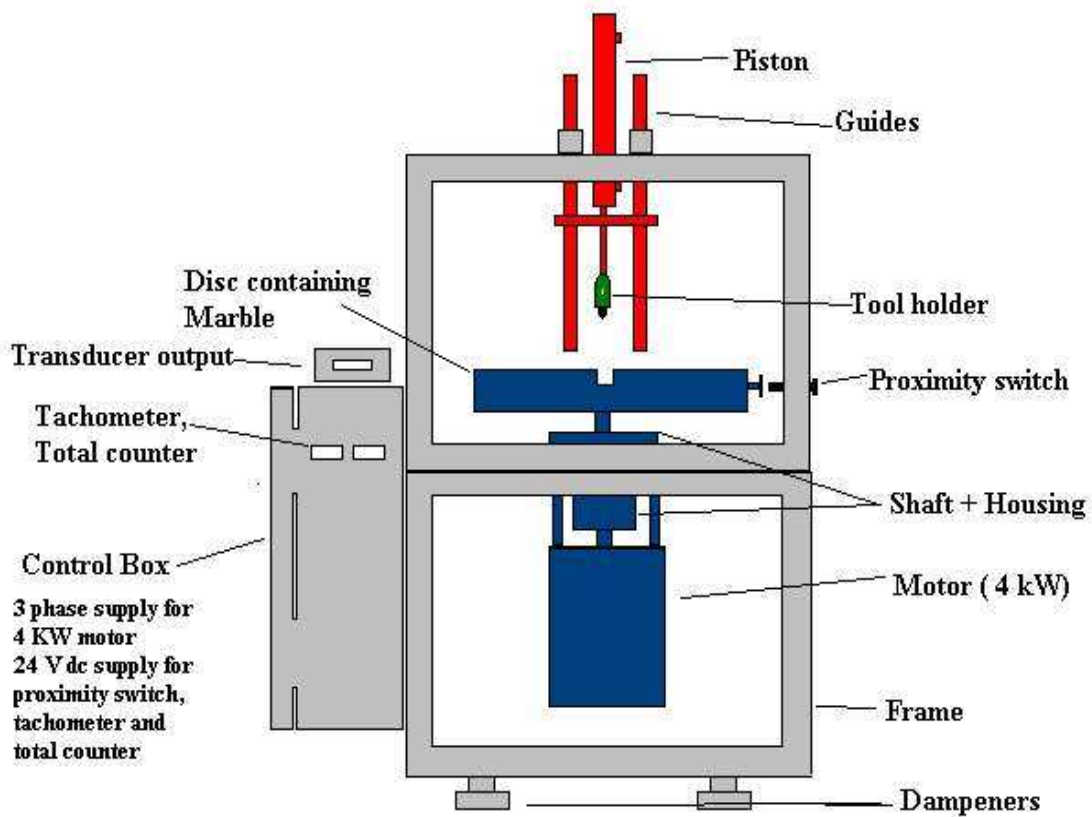

Figure 2. Pin-on-disc type testing Machine with dimensions base 500mm by 500mm and height 990mm.

The construction of the machine was carried out according to the design specification. The preliminary tests were conducted and the following modifications were provided to improve the testing performance:

- An inverter was added to alter the frequency to the motor thereby controlling the speed
- A hydraulic pump which is restricted through a pressure relief valve
- Pressure transducer was used to indicate the load applied to the disc
- Transducer digital output unit indicated the load applied
- A proximity switch was used to indicate speed and revolutions via a tachometer and total counter
- Safety measures were implemented.

4. Experimental results and discussions

On completion of the testing machine experimental work were conducted on two materials: marble and limestone. Diamond impregnated segments were used for various diamond sizes, concentrations and metal matrix compositions. In the table below listed the details of these diamond saw segments:

	Diamond Crystal Size	Diamond Concentration
Segment A	US Mesh 30/35	DC10
Segment B	US Mesh 30/35	DC40
Segment C	US Mesh 40/45	DC10
Segment D	US Mesh 50/60	DC40

4.1 Test results on Marble

Marble discs were tested by using two different diamond specimens. The testing was performed under the normal load 200 N and the speed of the disc was 2000 rpm. Figure3 shows the test results.

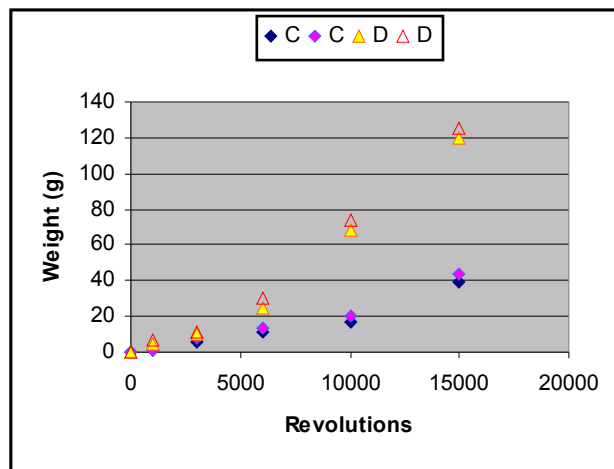

Figure3. The weight removed from marble sample against the revolutions of the marble disc.

Plotting the revolution of the tool segment travelled on the marble disc against the weight removed from the disc we can see an approximate linear relationship of the two parameters. The upper lines show the cutting performance of segment D, for which the size of the diamond is US mesh 50/60 and the diamond concentration is DC 40. It is obvious that this segment removes marble faster than the other type of segment, which is C. The test results show that under similar cutting condition the cutting performance is related to the diamond grit size and the concentration. The higher concentration and larger grit size are more efficient for removing of marble.

4.2 Test results on Limestone

Limestone discs were tested by using three different diamond specimens. The testing was performed under the normal load 200 N and the speed of the disc was 2000 rpm. The test results are showing in Figure4.

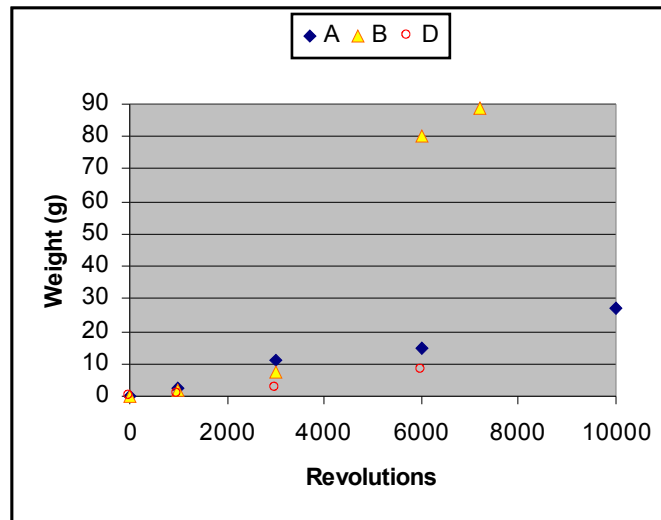

Figure 4. The weight removed from marble sample against the revolutions of the limestone disc.

The top line gives the cutting performance of segment B, for which the size of the diamond is US mesh 30/35 and the diamond concentration is DC 40. This segment removes marble most efficient in comparison with the other two segments. The middle line displays the results from segment A, and the bottom line are the results from segment D. Among three of them segment B has the highest concentration of diamond. The influence of the concentration on the cutting efficiency is most apparent. For the segments A and D, with the same concentration of diamond crystals, segment A, which has smaller grit size is more favourable for the cutting operation.

5. Conclusions

The pin-on-disc wear testing machine provides a possibility of simulating the cutting performance of a single saw segment, which can be used for the selection and development of diamond saw blade under variable conditions.

The method described enables different diamond segments to be tested at desired normal load at variable rotating speed.

The experimental results obtained provide valuable information on the performance of the single saw segment, which is related to the grit size and diamond concentration.

Further tests should be carried out on different types of diamond segment in order to predict their wear behaviors.

References

- [1] Jennings M., Wright. D., Guidelines for sawing stone, Industrial Diamond Review 2/89
- [2] Boothroyd G., Fundamentals of Metal Machining and Machine Tools, McGraw-Hill, Washington, 1982.
- [3] Dwan, J. D., A Design of a wear test machine for diamond impregnated tools. IMC-13, Cork, Ireland, Sept. 1996
- [4] Büttner, A., Das Schleifen sprödharter Werkstoffe mit Diamanttopfscheiben unter besonderer Berücksichtigung des Tiefschleifens, Diss. TU Hannover, 1975
- [5] Bienert, P. Dipl.-Ing., Kreissägen von Beton mit Diamantwerkzeugen, Hannover, Dissertation, Technische Universität Hannover, 1978.
- [6] Black S. C., Chiles V., Lissaman A.J., Martin S.J., Principles of engineering manufacture, 3rd Edit. Arnold. London, 1996