

8-1-2002

BS News

Follow this and additional works at: <https://arrow.tudublin.ie/bsn>

 Part of the [Civil Engineering Commons](#), [Construction Engineering Commons](#), and the [Construction Engineering and Management Commons](#)

Recommended Citation

(2002) "BS News," *Building Services News*: Vol. 41: Iss. 7, Article 1.

Available at: <https://arrow.tudublin.ie/bsn/vol41/iss7/1>

This Article is brought to you for free and open access by the Journals at ARROW@TU Dublin. It has been accepted for inclusion in Building Services News by an authorized administrator of ARROW@TU Dublin. For more information, please contact yvonne.desmond@tudublin.ie, arrow.admin@tudublin.ie, brian.widdis@tudublin.ie.



This work is licensed under a [Creative Commons Attribution-NonCommercial-Share Alike 3.0 License](#)

BSN News

MECHANICAL & ELECTRICAL BUILDING SERVICES

AUGUST 2002

**Calorifiers & Heat Exchangers
Systemair — The Straight Way!
Myson Heating Controls**



**Don Collins
Remembered**

Innovation in Pumping Technology



★ Wilo-BL, DL and IL range

This new range of glanded pump is suitable for mechanical building services applications such as Heating, Air Conditioning and Refrigeration. (-10 to +140°C). Available in single, twin or end-suction configuration, the new hydraulic design enables high efficiency operation and lower operating costs. Features include: standard frame IEC motors, bi-directional mechanical seals, cast iron impellers and IP 55 rating throughout the range.

WILO ENGINEERING LTD

Enterprise Centre, Childers Road, Limerick, Ireland
Tel: 061-410963 Fax: 061-414728
E-mail: sales@wilo.ie Internet: www.wilo.ie



BL



IL

Pumping-Perfection
and more...



BSNews

MECHANICAL & ELECTRICAL
BUILDING SERVICES

ISSN 0791-0878

Published by:
Pressline Ltd,
Carraig Court,
George's Avenue,
Blackrock, Co Dublin.
Tel: 01-288 5001/2/3 Fax: 01-288 6966
ISDN: 01 - 211 2338/9
eMail: bsnews@pressline.ie
Website: www.buildingservicesnews.com

Editor: Pat Lehane
Advertisement Director: Joe Warren
General Manager: Louise Byrne

Origination and Design:
Pressline Ltd. Tel: 01 - 288 5001

Subscription: One Year —€45

Printed by: Kilkenny People Printers.

© All editorial contents and all advertisements prepared by the publishers, Pressline Ltd.

* Incorporating Irish Heating & Ventilating News.

Readership Data

Irish Building Services News (formerly Irish H&V News) is Ireland's only Building Services magazine providing coverage of heating, ventilating, air conditioning, refrigeration, sanitaryware, plumbing, maintenance and environmental industries. It is the only publication catering exclusively for these industries and its circulation includes members of the following:-

Chartered Institution of Building Services Engineers (CIBSE); The Mechanical Engineering & Building Services Contractors' Association (MEBSCA); The Association of Consulting Engineers of Ireland (ACEI); The Mechanical Engineering Contractors' Association; The Institute of Domestic Heating Engineers (IDHE); The Registered Heating Contractors Association; The Maintenance, Energy & Environmental Technology Association (MEETA) which incorporates energy managers and maintenance managers; The Energy Conservation & District Heating Association; The Institute of Plumbing; The Irish Home Builders Association (IHBA); Builders Merchants/Trade Supply Outlets; Irish Property & Facilities Managers Association.

In addition, Irish Building Services News circulates to independent building services contractors and key executives in industry, Government, Semi-State and local authority bodies. Essentially, our circulation is virtually saturation coverage of all those with an interest and/or involvement in the industry.

O P I N I O N

Don Collins Remembered

The untimely death of Don Collins earlier this month has left his many friends and colleagues stunned. A gentleman of the old school, Don was not just liked and respected by all who knew him, but actually loved, especially by the close-knit group who were privileged to count him as a true friend. Here, and inside on page 44, he is fondly remembered.

I worked closely with Don for the past 12 years and my memories of him are of a consummate professional. Each task was tackled with diligence, flair and enviable organisation. He embodied the principle that the customer always comes first no matter what and he lived that principle. My special memories of Don are of a wonderful colleague and friend with a wicked sense of fun and mischief.

We often changed the ringing tone of his mobile and it frustrated him because he never quite mastered the menu to enable him to change it back. We'd untidy his desk to the response, "Ah Jeez! Donohoe that's messing — leave it alone, I don't want anyone to confuse it with yours."

His track record at getting one up on me is a legend within Barlo, Veba and Merriott. He planned his attacks weeks in advance. It was even more fun if he could tell everyone else what he was up to so they all knew except me.

A group of us got together six or eight weeks ago and he got me again to which I replied, "I'll get you Collins," and I set my plan afoot. Sadly, fate intervened.

Even now I can visualise him looking down from a perfect green, grinning broadly, licking his index finger and chalking another imaginary victory line in the sky with the words — Gotcha Again Donohoe!

Frank Donohoe

I N T H I S I S S U E

Product Review: Calorifiers & Heat Exchangers	2
Myson Heating Controls ... From Metal Bashing to High-tech Innovators	18
Trade News	20
Solar Energy — The Sun Never Sends A Bill!	40
BTU Results From Malahide and Old Conna	41
Property and Facilities Management	42
Don Collins: An Appreciation	44

'Europak' Fully Packaged Heat Transfer Unit

While Eurofluid Handling systems is a relatively small company, it has a wealth of in-house experience and technical know-how. Moreover, through its principal trading partners — Sondex, Grundfos and ACV — it has instant access to the enormous resources these multi-national corporations represent.

This is especially true in respect of Eurofluids' Europak fully-packaged heating transfer unit. This unique product is supplied complete with a Sondex gasketed plate heat exchanger capable of recovering the contents of a buffer vessel within a specified time period when supplied with primary boiler water. Boiler load available — up to 1 megawatt.

Europak comes complete with the following:

- Grundfos twin head in-line primary pumpset;
- Grundfos single in-line bronze circulator type;
- 3-port lift-and-lay motorised valve with control sensor fitted to buffer return line;
- All isolating gate valves and non-return valves;
- Fully pre-piped and pre-wired;
- Fully-automatic control panel, c/w digital controller, run/trip pump and power-on lamps;
- Panel-mounted digital temperature indication.

The completely packaged unit is mounted on a common baseframe, primed, painted and tested prior to despatch.

As for the Sondex heat exchangers themselves, these are world-class, highly-compact, high-performance heat exchangers which are based on the corrugated plate concept. By combining various numbers of high-precision, standardised plate designs into complete, extremely-compact units with various connection configurations and sealing techniques (gaskets, brazing, glue, welding etc), Sondex achieves almost infinite flexibility to meet the needs of each individual customer.

The construction of the inlet part makes a perfect distribution of the liquids across the heating part. The inlet part is increased and supplied with grooves preventing "dead spots" which may cause the growth of bacteria in the plate heat exchanger. The inlet with grooves secures a strong inlet part with a minimum of contact points.

The inlets are constructed with a leakage drainage zone fulfilling the 3A specifications.

The plate pattern is available in two designs with different angle sizes giving high respectively low turbulent flow.

Combining these in a plate

pack, an optimal composition can be calculated.

In order to strengthen the gasket groove Sondex "sonder flex line" is supplied with deep speed-edged grooves giving perfect hold of the gasket. This means a long durability for gaskets as well as for plates.

The gasket is placed in the total protected gasket groove. This construction secures the elasticity of the gasket, even after long time of assembling. The new generation of Sondex plate heat exchangers is developed with the glueless "Sondex Lock" gasket. This is fixed by strong rubber buttons which, contrary to most glueless gaskets of today, really fix the gasket in the groove.

The economical advantages are clear: performance optimised to a particular application, combined with the use of standardised parts and manufacturing procedures, and amazingly-compact design.

Sondex's continuous research and development work is customer-driven, designed to anticipate customer requirements and exceed their expectations. The bottom line for Sondex is to provide tailor-made solutions in a cost-effective manner, using standardised components.

Sondex heat exchangers are typically up to just one-tenth the size of conventional shell-and-tube exchangers for any given performance rating. That means correspondingly less heat transfer medium, smaller pumps; less piping; and less energy consumption.

Eurofluid Handling Systems will devise a customised solution, whether the request is on HVAC or industrial applications.

Contact: Bernard Costello, EHS.
Tel: 01 - 450 3884;
Fax: 01 - 450 7634;
email: eurofluid@tinet.ie



Examples from the extensive Sondex range distributed by Eurofluid

Assos Calorifiers

exclusively available from heatmerchants

- Assos exclusively manufacture calorifiers for the production and storage of hot water.
- Assos calorifiers are the most modern and technically advanced in Europe today.
- They are manufactured to German DIN standards.
- Assos calorifiers are high pressure, high recovery, hot water systems.



2 types available

Wall mounted models

Sizes available are 100 & 120 ltrs., c/w coil and optional 4kW. immersion.

Floor mounted models

Various options from 150 ltrs. to 1000 ltrs., in 1 or 2 coil options.



heatmerchants

incorporating **Gas & Oil Parts**

Branches Nationwide

www.heatmerchants.ie

The ACV Tank-in-Tank and Delta Concepts

ACV International has been making boilers and domestic hot water products for more than 75 years. Increasingly, large-scale applications have

become a speciality. Wherever hot water is needed and reliability is paramount, ACV is the answer.

Over the years ACV

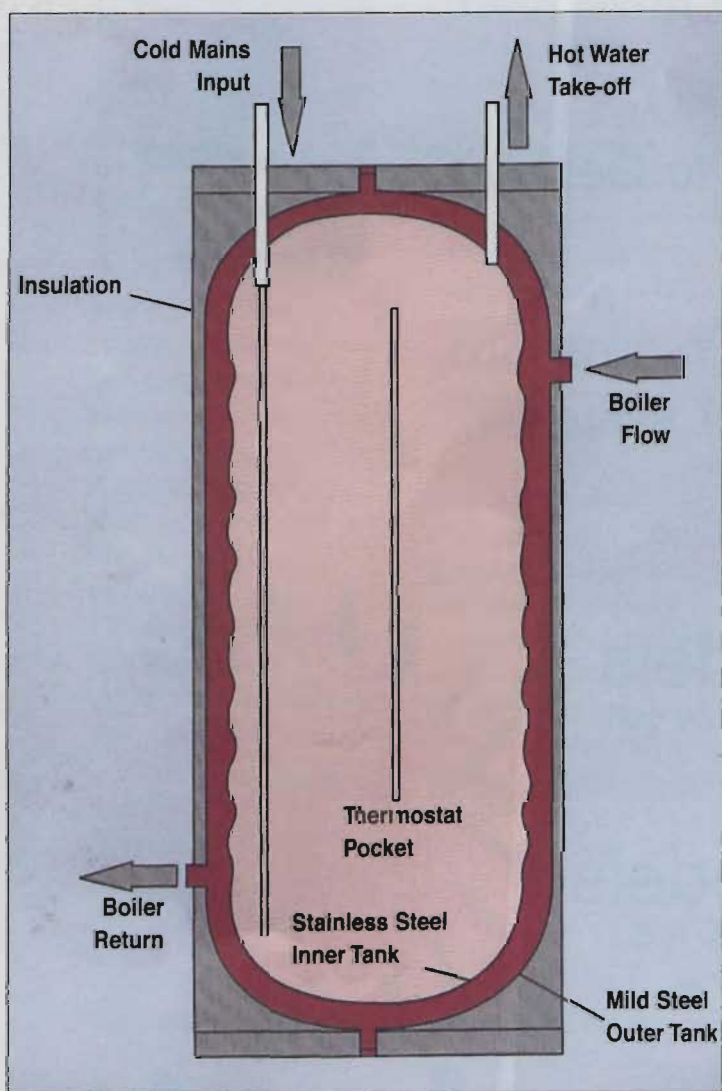

has been responsible for quite a number of inventive and innovative industry "firsts", the most notable being the Delta and Tank-in-Tank concepts.

Delta

The "Delta" was conceived in 1974 and is, in effect, a domestic hot water (DHW) generator which is also capable of providing central heating. It operates equally well with gas or oil firing, and is available over a wide range of outputs.

The ACV-developed Delta is probably the first appliance to put the accent on domestic hot water generation. Its concept is the complete opposite to the traditional system where the cylinder is simply considered to be an accessory of the boiler. The Delta is nothing but a hot water generator which has solved the problems associated with lime deposition by introducing a primary circuit. From this it was only one step to use it as a boiler. An extensive model choice is now available.

A typical example is the Heat Master dual-function direct-fired water heater ... and boiler.

Tank-in-Tank

The name "Tank-in-Tank" was coined at the beginning of the 1980s to describe a type of tank which could not be classified either as a cylinder with a coil, or as a twin-wall tank.

The difference between ACV tanks (cylinders) and those with coils is clear, because in the ACV tank the primary fluid heats the domestic hot water (DHW) from the outside in, while the others heat from the inside out.

The decision to use stainless steel for the manufacture of the Tank-In-Tanks was made because of its well-established reliability over other materials. It is stable at elevated temperatures, which is not always the case for cylinders manufactured from mild steel and protected by a coating. ACV tanks are capable of storing domestic hot water at elevated temperatures of up to 85°C. Applications for the ACV Tank-In-Tank principle are widespread and include district heating schemes, solar energy systems and even connected to a heat pump.

Contact

C&F Quadrant.

Tel: 01 - 630 5757; Fax: 01 - 630 5706;
email: sales@cfquadrant.ie

Contact

Bernard Costelloe, Eurofluid Handling Systems.

Tel: 01 - 460 0352; Fax: 01 - 450 7634;
email: eurofluid@tinet.ie

BOSS/Albion Storage and Non-Storage Calorifiers

Commercial Range

BSS are pleased to introduce a new range of BOSS/Albion Storage Calorifiers to their extensive range of heat exchange products.

The BOSS/Albion Storage Calorifier Range has been developed to reduce the time taken in gaining drawing approval.

They are available in 13 standard sizes ranging from 280 litres capacity to 2000 litres.

The BOSS/Albion Commercial Range is manufactured to a commercial standard and is available as an optional extra with insulation which would need to be specified at the time of ordering.

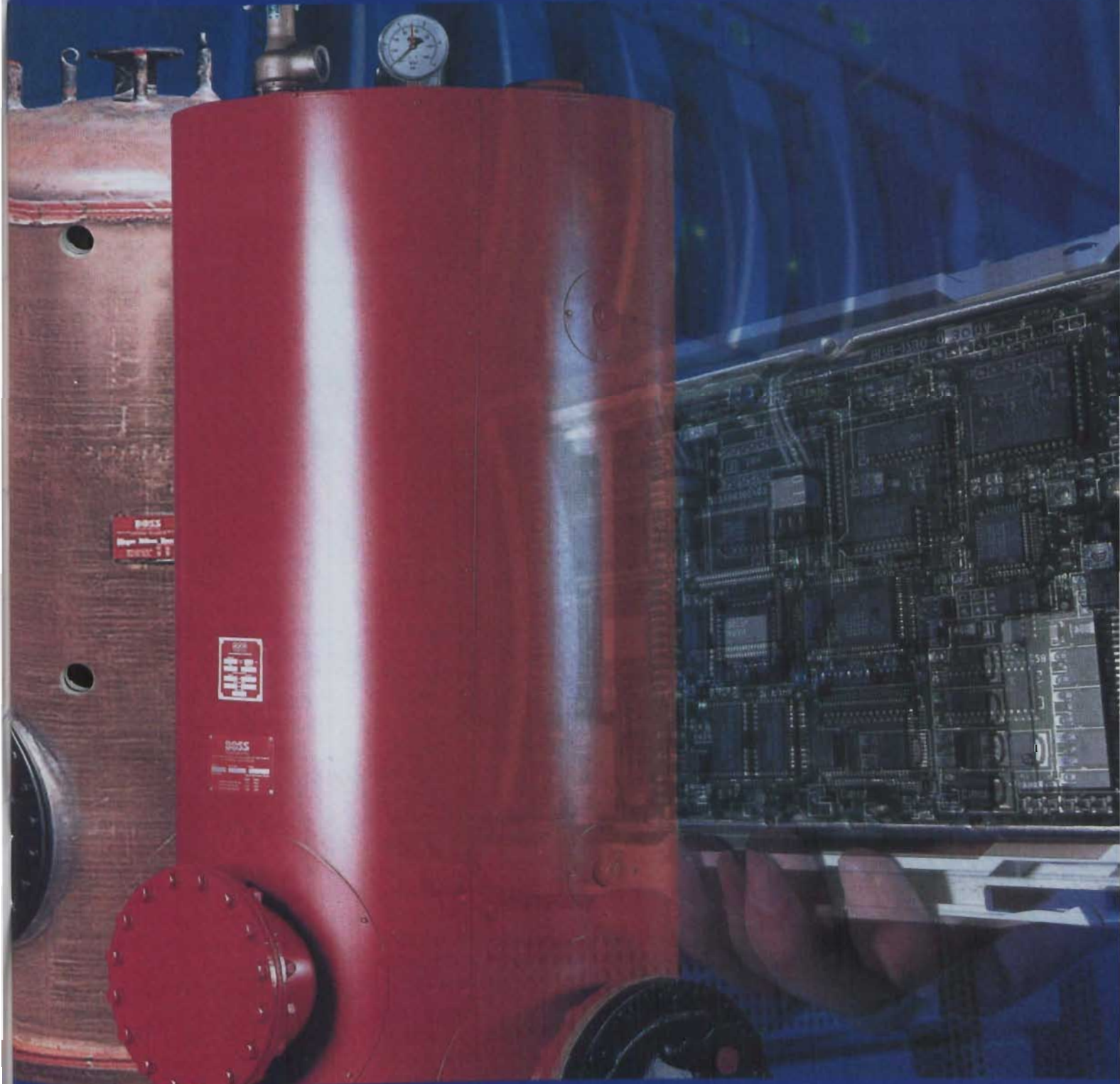

Published by ARROW@TU Dublin, 2002

BSS (Ireland) Ltd,
White Heather Industrial Estate, 301 South Circular Road, Dublin 8
Tel: 01 - 416 5100; Fax: 01 - 416 5165;
email: 1930.sales@bssgroup.com

'For Post Installation Peace of Mind, Use Copper'

Since the 1940s copper has become the pre-eminent plumbing and heating material in many countries of the world. A correctly-designed and properly-installed copper system will stay almost maintenance-free for the lifetime of the building, giving peace of mind and confidence, writes *Conor Lennon of Irish Metal Industries*.

Post installation responsibility for the plumbing and heating system lies with the specifier. Copper systems have a number of benefits to ensure that post installation problems are minimised.

Copper systems are strong and durable ... the tensile strength of annealed copper tube is at

least 200N/mm² and more than 300N/mm² for hard drawn tubes.

Copper offers a combination of properties that makes it unique. Copper handles extremes of heat with no problems, side effects or long-term degradation. In fact, copper and its alloys maintain acceptable physical, chemical and mechanical properties between -196°C and 205°C, which means that it is used in applications as diverse as cryogenics and steam lines.

Copper also has a low coefficient of linear expansion. For example, a 6m length of copper tube joined to a boiler with a working temperature of 82°C will only increase in installed length by about

7mm. Certain plastic materials expand 10-15 times more than copper.

Copper offers excellent resistance to fire and does not generate toxic fumes. As a result, it is now approved in the UK for domestic fire sprinkler systems by the Loss Prevention Council.

Copper is ideal for use with sprinkler systems. It's inherent strength ensures that it has excellent flow rate benefits. As small diameter pipes are used, installers benefit from copper's lightness, manoeuvrability and easy jointing.

Copper and its alloys are well known to have excellent corrosion resistance, not only from their surroundings, but also to the many different water quantities conveyed.

A copper plumbing and heating system offers a high level of safety and reassurance due to its ability to withstand high system working pressure, including pressurised hot water and sealed central systems.

Some central heating systems are vulnerable to oxygen ingress, which causes corrosion in steel radiators and iron boilers. Oxygen is known to pass through certain other materials and into the circulating water with highly-corrosive results on ferrous components.

Copper is the most commonly-used plumbing material that offers complete impermeability to oxygen.

As a homogeneous metal, copper is the most extensively used plumbing material which is completely impermeable to hydrocarbons. Copper plays a vital role in maintaining the integrity of the water supply. Copper systems keep out viruses and bacteria; oxygen; harmful fluids; herbicides/insecticides; and fats, oils and solvents.

Remember, certain plastic materials are susceptible to permeation by many commonly-found hydrocarbons, which may cause water to be contaminated and pipework to deteriorate.

Finally, certain other plumbing and heating systems are only being developed in a limited variety of sizes. They are not universally available from plumbing and heating stockists. If retrofitting is an important part of your work, you need to be sure of the availability of product well into the future. If you use a copper system you can be sure that the parts you need for retrofitting will be readily available when needed.

Contact: *Conor Lennon, Irish Metal Industries*.
Tel: 01 - 295 2344;
Fax: 01 - 295 2163.
Email: conor.lennon@irishmetaliindustries.com

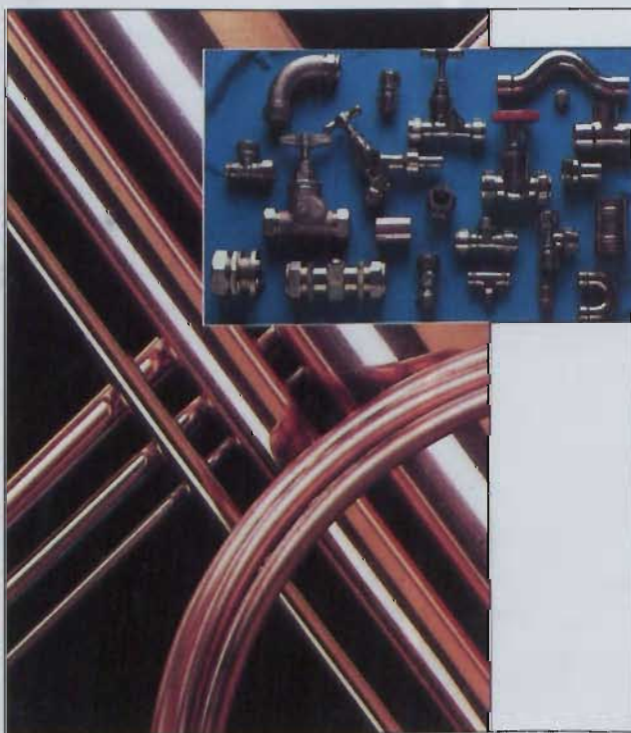

Full Range!

Each application demands its own type of Heat Exchanger. Pressure, temperature and the type of fluid are all critical. Whatever your application, SWEP PHE has a solution. Together with Tranter Inc. we represent one of the worlds largest range of Heat Exchangers.



Conventional types

- Ultra Flex types
- Wide Gap types
- Semi-welded types
- Double Wall types
- Max connection size 500 mm

Fully welded

- Maxchanger
- Supermax
- Ultramax
- Max connection size 150 mm

Platecoil

- Single Coils
- Manifolded banks
- Clamp on
- Complete vessels

Discover the full range at
www.swepphe.com



SWEP International PHE



RSL Ireland Ltd

Belfast: 048 - 9037 0595; Cork: 021 - 431 7221; Dublin: 01 - 450 8011; Galway: 091 - 757 818
 email: info@rslireland.com

CALORIFIERS & HEAT EXCHANGERS

Boss Albion Commercial Calorifiers

BSS has introduced a new range of Boss Albion storage calorifiers to its extensive range of heat exchanger products. Developed to reduce the time taken in gaining drawing approval, units are available in 13 standard sizes, ranging from 280 litre to 45000 litre capacities. Manufactured to BS 853 1966 Part 1 Grade A and M&E 3, insulation can be specified as an optional extra at the time of ordering.

The Boss Albion range comprises a comprehensive choice of commercial sizes to suit a variety of

applications. Units can be designed to work at different pressures and manufactured for main pressure, vented or unvented, use. There is also a range of calorifiers with a quick recovery. The AQR ranges gives 20-minute recovery at 60°C from 10°C using primary water at 76.5°C mean water temperature (82°C flow / 71°C return). These units are fully insulated with either CFC-free ecofoam insulation or 50mm fibre insulation cased in aluminium or galvanised steel sheet.

Boss Albion has a long history in designing and manufacturing



BSS has an extensive range of Boss Albion fast-recovery calorifiers

calorifiers and has been involved in many prestigious developments for leading blue-chip companies. These include Abbots, Shell, BBC, Natwest Bank, etc, along with

specialty-tailored designs for use in prisons, hotels, schools, leisure centres and golf clubs. Certified drawings can be issued with all calorifiers, as well as test certificates.

Shell and heater units are tested to a minimum of one and a half times working pressure independently, and insurance inspections are welcome by prior appointment.

Boss Albion offers a full design service and is able to respond promptly and efficiently to specifiers, contractors and engineers who require a flexible approach to individual customer requirements.

Contact: John Brophy, BSS Ireland (Dublin).
Tel: 01 - 416 5100;
Fax: 01 - 416 5165;
email: 1930.sales@bssgroup.com
Michael Quinlan, BSS Ireland (Cork).
Tel: 021 - 432 1588;
Fax: 021 - 432 1595;
email: 1960.sales@bssgroup.com

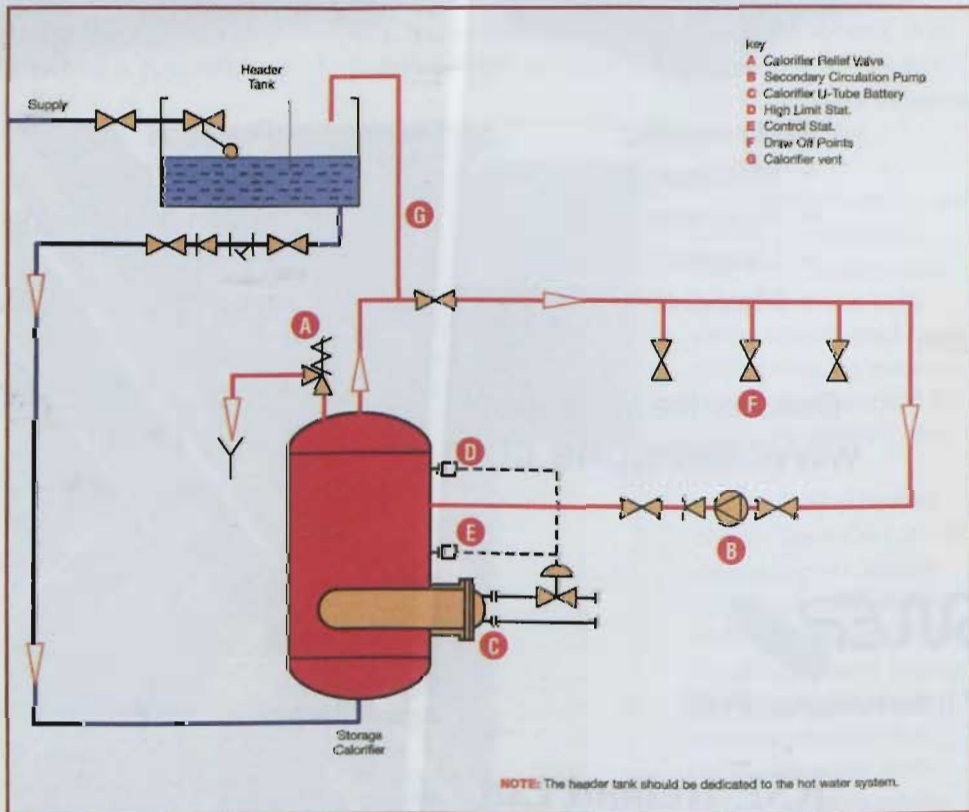

Schematic showing a Boss Albion storage calorifier fitted in a typical unvented DHW system



All our tubes are up to the Mark

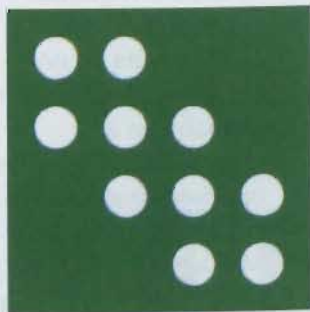

**IRISH METAL
INDUSTRIES**

Irish Metal Industries supply a complete range of copper tube for hot and cold water installations, gas services, sanitation, central heating and numerous other building and engineering applications.

All our tubes are manufactured to the stringent requirements of EN : 1057 and we are licensed to engrave them with the coveted Irish Standard Mark which is the registered mark of the National Standards Authority in Ireland. What's more we give a unique **25 year guarantee** against manufacturing defect. So what ever your requirements you'll receive nothing but the best quality, service and reliability with copper tube from Irish Metal Industries.

Service Line: For orders and further information.

Telephone: (01) 295 2344/295 2137.

Fax: (01) 295 2163

Irish Metal Industries Ltd, 25 Spruce Avenue,
Stillorgan Industrial Park, Blackrock, Co Dublin.

IMI
A subsidiary of IMI plc.

CALORIFIERS & HEAT EXCHANGERS

Assos Glasslined Calorifiers

Assos exclusively manufacture calorifiers for the production and storage of hot water. They are the most modern and technologically-advanced in Europe today, offering the highest operational security, a very efficient and economical operation, and a variety of models able to fulfil all consumer needs.

The Assos calorifier provides improved safety and economy in the consumption of heat energy because:

- It is designed and constructed according to the international and European safety and efficiency standards (ISO, EN, DIN, ELOT);
- It has the CE approval;
- A thicker steel sheet able to withstand pressure of 13-bar constructs the calorifier;
- The calorifier is enamelled using the advanced double direct method fired at 850°C ensuring a more effective protection thus providing Assos calorifiers with a long-lasting life even in a hard water environment;
- The larger magnesium anode provides additional protection for the calorifier and complies

- with all health standards;
- The large "Manhole" (cleaning door) allows easier access for the cleaning process, enhancing its durability while at the same time ensuring the supply of purer water, thereby improving the quality for our lives;
- The insulation, which is 2.5cm thick and has a density of 40 Kg/m³, is made from environmentally-safe

polyurethane, which helps maintain the temperature for a longer period of time.

The calorifiers can be broken down into two main types — wall/floor-mounted models and floor-mounted models. Brief details are as follows.

Wall/floor-mounted models — These are available in two sizes, 100litre and 120litre, complete with coil and optional 4kW immersion. The units can be sited horizontally or can be wall-mounted by using the attached brackets.

Floor-mounted models — The floor-mounted models are available in a range of models ranging from 150lts to 1000lts in a 1-coil or 2-coil option. The calorifiers are supplied with a high recovery coil, which enable the unit to recover in the shortest time possible.

All Assos calorifiers can operate up to 10bar max @ 95°C, which is ideal for houses where a large quantity of high pressure hot and cold water is required to run baths, showers etc. Unvented kits are sold with calorifiers that are required for such systems. The unvented kit makes the calorifier safe while having pressurised water at the same time. An optional heat source is available to boost the heating of the water. The immersions are available in two sizes — 4kW single-phase and 6kW 3-phase. Also fitted on the calorifier is a secondary return connection which can be used if required.

The 800lts and 1000lts units do not come insulated and are available in a galvanised material as opposed to glasslined.

Contact: Macartan McCague, Heatmerchants Dublin. Tel: 01 - 616 0510; Mobile: 086 259 3085, email: macartan.mccague@heatmerchants.ie



An example from the Heatmerchants' range of glasslined calorifiers by Assos



Tank-in-Tank & Delta

Unique water
heating
concepts

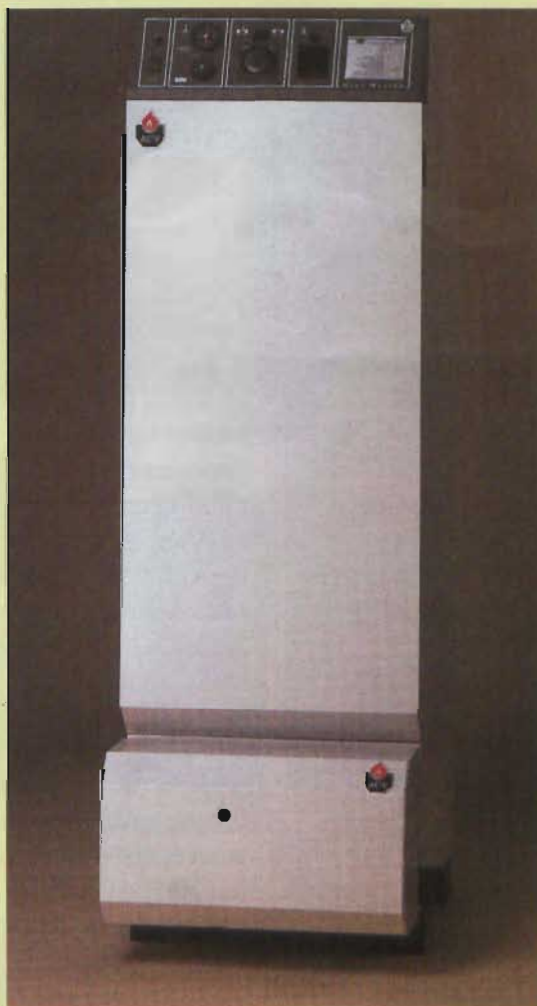

Direct fired water heater ... and boiler
the dual function HEAT MASTER
from ACV

Contact

EHS
Eurofluid Handling Systems

Unit 12, The Westway Centre,
Ballymount Avenue, Dublin 12.
Tel: 01 - 450 3884/460 0352/460 0353;
Fax: 01 - 450 7634



Tel: 01 - 630 5757;
Fax: 01 - 630 5706;
email: sales@cfquadrant.ie

CALORIFIERS & HEAT EXCHANGERS

Taney Combines A O Smith with Vaillant ...

In recent years A O Smith has recognised the trend towards indirect storage tanks in the industrial water heater sector. A O Smith has been a pioneer in the development of the storage water heater and calorifier markets.

Its range of indirect storage tanks, range in capacities from 300 to 1007 litres suitable for installation with a variety of heat sources. The tanks can be supplied ready assembled with insulation and jacket factory-fitted, or as an insulated tank with separate jacket to be

fitted on site. The latter option avoids possible damage during transportation and installation. The jackets are available in blue and stainless steel effect. Insulation is provided in a choice of CFC-free PU foam or melamine.

All internal surfaces are glass-lined to prevent corrosion. Additional protection is provided by a sacrificial magnesium anode. Each IT storage tank is fully tested to a maximum working pressure of 10 bar (maximum test pressure 12 bar) and guaranteed for three

years against leakage caused by material or manufacturing defect.

A O Smith products are distributed in Ireland by Taney Distributors, who have provided a sales, technical and service facility for the American manufacturer for over 20 years. Taney has been able to complement the A O Smith indirect storage tanks with Vaillant wall hung gas boilers, the latter providing a very efficient source for the tanks. Vaillant is recognised as among the most efficient, reliable and technically

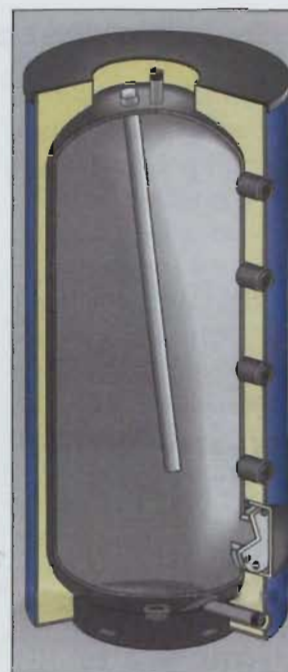

A O Smith storage tanks suitable for installation with direct fired glass-lined water heaters, plate heat exchangers and other semi-storage or instantaneous sources of heat.

innovative products in the gas boiler market.

Contact: Neil Gaffney, Taney Distributors.
Tel: 01 - 450 8120/456 5475/456 6742;
Fax: 01 - 450 0051.;
email: taneydist@eircom.net



The drop-down control box provides easy access to all components, facilitating service work.



Vaillant Teomax condensing, combination, and system boilers are available from Taney Distributors.



SONDEX

World of Heat Exchangers



By means of technological innovation SONDEX has developed and designed a new generation of plate heat exchangers and freshwater generators.

With a wide range of plate heat exchangers SONDEX has got the optional technical solution for any possible task.

Our product range for freshwater generators covers capacities from 1-1000 tons per 24 hours.

Brazed Plate Heat Exchanger

- District heating, heating and ventilation
- Solar heating and airconditioning units
- Heating pumps and heat recovering units
- Hydraulic and fuel oil units



EHS
Eurofluid Handling Systems

Unit 12, The Westway Centre, Ballymount Avenue, Dublin 12.

Tel: 01 - 450 3884/460 0352/460 0353; Fax: 01 - 450 7634;

Email: eurofluid@tinet.ie

SWEP Plate and Frame Heat Exchangers for HVAC Applications

There are many applications in the building services industry for heat exchangers. Here Alan Ashton of SWEP Ltd PHE (Irish distributors RSL Ireland) examines some of these and discusses the advantages of plate heat exchangers over the traditional shell and tube.

The market for heat exchangers has grown

out of the need to control environments while reducing energy bills. To match the best heat exchanger to the exact application, a specifier must have a choice of heat exchanger equipment, taking into account efficiency, operating temperatures and pressures, the product's fluid properties, space, maintenance,

multiproduct usage on the same equipment and price.

Cooling tower applications

Cooling tower water circuit isolation —

Cooling tower water is usually contaminated with solids and corrodents, and so it is undesirable to pump it through expensive chillers or unitary heat pumps. Plate and frame heat exchangers (PHEs) are regularly installed between the cooling tower and the cooling equipment. They are easily cleaned, corrosion-resistant, and more efficient than shell-and-tube units because of their close temperature approach characteristics.

Free cooling during moderate temperatures (chiller bypass) —

Through the years there are many periods when the wet bulb or ambient temperature is low enough to provide adequate cooling using cooling tower water directly. Whenever such conditions exist a plate and frame heat

exchanger used in a bypass circuit allows the chiller to be shut down, resulting in sizeable savings.

Isolations of river, lake, waste or seawater coolants —

Even after filtration, river lake waste or seawater normally contain solids that may be corrosive. The use of anti-corrosive PHEs will protect the equipment.

Static head isolation in tall buildings —

Tall buildings can be divided into several zones for chilled water piping. By using the several zones with plate and frame heat exchangers at different elevations, the pressure from the static head is eliminated. This allows the use of lower pressure piping and valves, while the close approach temperatures possible with the units result in superior efficiency, compared to a shell-and-tube system.

Thermal storage: isolation of storage tank —

It is becoming increasingly common to utilise spare chiller capacity at times of low demand to cool water in a storage tank for use when the load is heavy. Stored water often develops a high solids content or may be otherwise

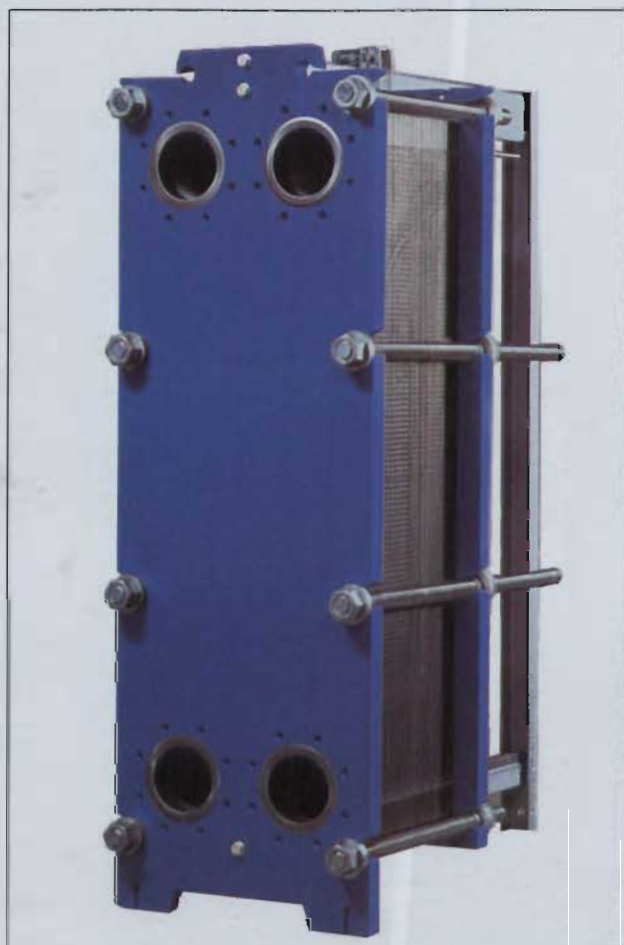

IT Storage Tanks

- A range of indirect storage calorifiers with capacities between 300 and 1007 litres
- Outputs 47 to 145kW
- Glass-lined steel tank with sacrificial anode for maximum resistance to corrosion
- Manufactured in the Netherlands
- ISO 9002
- Choice of jacket materials, available in two colours
- CFC free foam insulation or soft melamine heat retention and durability
- Range of options, ancillaries, and electrical heating elements



TANEY DISTRIBUTORS

LIMITED

Unit 4, Riversdale Industrial Estate, Bluebell Avenue, Dublin 12
 Tel: 01 - 450 8120/456 5475/456 6742; Fax: 01 - 450 0051
 email: taneydist@eircom.net



Manufacturers of quality ventilation products



Tel: 01 882 8411 Fax: 01 882 8412
 BRENDAN O'TOOLE : Mobile: 0872 572099
 DAVE CONNELL : Mobile: 0879 198388

"Knowledge in Ventilation"

Unit 13, Tolka Valley Business Park, Ballyboggin Road, Dublin 11
fantech@eircom.net www.fantechventilation.com

CALORIFIERS & HEAT EXCHANGERS



contaminated, and the PHE is ideal to isolate this water from the rest of the system.

Water source heat pump pre-cooler with isolation

— The return water from the air conditioning load can often be cooled considerably by use of the water source directly, reducing the load on the chiller. The isolation PHE unit prevents contamination of the condenser.

Heating & Heat Recovery

Heating potable hot water (instantaneous heater) — PHE units offer very high heat transfer rates, allowing a smaller, more compact water heater than would normally be required, and are excellent for heating

potable water with low pressure steam or hot water. The stainless steel plates provide a clean, smooth surface for use with potable water.

Waste heat recovery from condenser water —

Water going to a cooling tower from a condenser is frequently warm enough to be useful for preheating make-up water or winter air. A PHE can reduce heating costs by recovering this “free heat”.

Water source heat pump isolation —

Heat pumps are being increasingly used as energy costs go up. Water used as the heat source, or heat sink for such systems, is generally contaminated with solids or scaling tendencies, etc. The PHE, with its close

temperature approach characteristics, efficiently isolates this water from the heat pump system exchangers.

Waster heat recovery from condensate or boiler blow-down —

Condensate frequently requires cooling so that it will not flash, and in some instances, condensate is not returned to the boiler. In both situations, heat can be recovered with a PHE unit to save fuel. Heat is also frequently recovered, and savings realised, from boiler blow-down.

Waste heat recovery from overheated areas —

Water used for cooling overheated areas, such as computer rooms, is frequently warm enough to allow heat recovery. This is more practical with a PHE unit than with a shell-and-tube system, because of its close approach temperatures.

Heating water/glycol fluids for space heating

— Non-freeze water/glycol heating media are often used where heating coils can freeze in cold weather when a pump or steam supply fails. These are ideally heated with PHE units. Typical uses are for heating underground garages and for perimeter heating near ground

floor doors that are opened frequently.

Summary

The above outlines just some of the common applications for heat exchangers in the building services industry. Depending on the climate heat and environment, heat exchangers are used with solar panels, geothermal heating and many varied heat recovery applications.

The plate and frame heat exchanger is increasingly replacing traditional tubular storage and non-storage exchangers, because of its compact nature and weight, its ability to be cleaned easily and to expand the number of plates as demand increases.

The economic use of high grade corrosion-resistant materials, ease of maintenance, a space-saving design and the provision of locally trained service engineers, is ensuring that the SWEP plate and frame heat exchanger is the natural choice for the building services industry.

Contact: Gerry McDonagh, RSL.
Tel: 01 - 450 8011;
email: info@rslireland.com
Website: www.rslireland.com

HAIER MRV — MULTI-SPLIT AIR CONDITIONING FROM CORE AC

As the fifth largest manufacturer of consumer goods in the world and with sales of approximately €7.5 billion in 2001, Haier is fast becoming a leading worldwide brand across all market segments. This is particularly true of air conditioning where last year alone the company produced six million units. New products are produced at a rate of 1.3 per day with an average of 2.5 patents being registered per day. Design expertise and manufacturing quality are the cornerstone of the company's success. Moreover, this quality excellence is provided at exceptionally competitive prices, the massive buying and manufacturing power of the company making for very low unit cost production.

A typical example is the new MRV multi-split air conditioning system. This a high-quality, low-cost, mini VRF system with a host of unique features providing innovative end-user benefits.

6 Indoor To 1 Outdoor

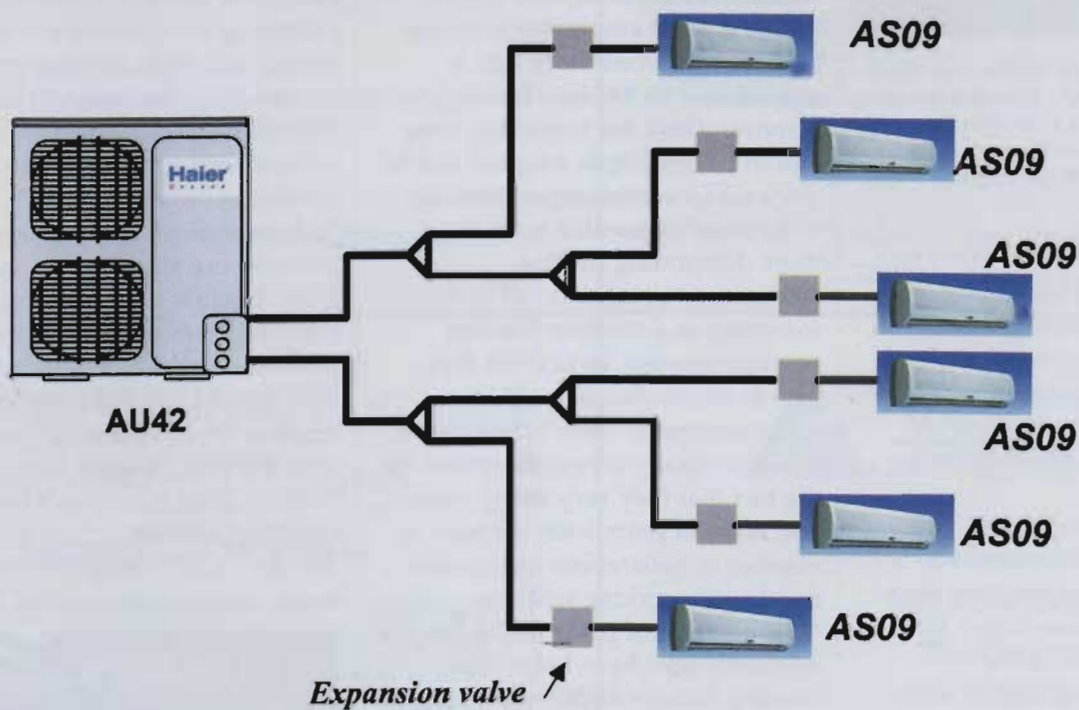

Only wall mounted types are connected with expansion valves

- Up to six indoor units to one outdoor unit
- Single-phase supply
- Option of 3-phase also available
- Latest inverter compressor technology
- 100 metre linear pipe separation (50 meters to each circuit)
- Variable capacity — indoor units only deliver the amount of cooling or heating required
- Individual remote controls
- R22/R407C
- Energy efficient
- Low start current
- Quiet outdoor operation



Unit C1, Three Rock Road,
Sandyford Industrial Estate, Dublin 18.
Tel: 01 - 294 3110; Fax: 01 - 294 3115
email: info@coreac.com



From Metal Bashing to High-Tech Innovators



Myson Heating Controls' Plastic Pipe Valve (PPV) concept is simple ... the valve has an integral 90° elbow with push-fit collet assembly. As can be seen above, it is the perfect solution, both technically and aesthetically.

When first established 33 years ago, the forerunner to what is now Myson Heating Controls was a typical, traditional, "metal-bashing" operation. It was low-tech and fundamental with basic, simple, aspirations. So it continued for the next decade or so.

However, 21 years ago Sean Hanratty entered the frame. He joined as accountant but very soon his dynamic influence began to permeate all aspects of the company's activities. Within seven years he was appointed Managing Director and thus began in earnest Myson's transformation from a mere metal-bashing operation into one of

One To Look Out For

A major breakthrough in controls technology will be unveiled next month. It is highly-sophisticated, technologically-advanced, multi-functional, and fully tested and quality approved.

the most high-tech, innovative, manufacturing operations in Europe. That is not to suggest that it was all plain sailing. Far from it. Over the years the company has experienced the usual array of traumatic events one would expect for such a long-established business. Nonetheless, the focus has always remained steadfast, as indeed has the vision — and determination — of Sean Hanratty and his management and shopfloor colleagues.

"More than anything else", says Sean, "it is the employees who are behind the success story that is represented by Myson Heating Controls. Over the years they have had to be flexible; to adapt to and to embrace new production methods; to be more responsive to an ever-more demanding trading environment; and to do all of the foregoing in a constructive and positive manner. To say that they rose to the challenge is an understatement. Their commitment to the company is best illustrated by the fact that they very rarely leave and now, 33 years later, we have a number of generations of the same family still working with us.

"It is a source of pride for us that the engineers who have helped us develop today's highly-sophisticated and innovative products are all local, most of them coming to us from the NIHE in Limerick. In that sense it is a truly home-grown success story with Myson heating Controls devising and bringing to the marketplace far-reaching new product solutions which have worldwide applications. An added bonus is that much of the components we use are also manufactured here in Ireland, thereby providing additional employment."

From a management point of view the loyalty of the workforce has been rewarded and fostered by a

programme of continuous investment in plant and equipment, product development, staff training, and market development. Myson Heating Controls enjoys significant market shares in the various product categories served. These are as high as 80% in some market segments here in Ireland, while they are also growing rapidly on the export front, especially in the UK.

Something like €35 million has been invested in the Newcastle West plant over the last 10 years and this process of re-investment of profits — people and plant and equipment will continue into the future. The objective is to develop even higher value-added controls products which can be produced efficiently and to the most exacting quality and performance standards.

It is a formula which has proven extremely successful over the last 21 years and one which will be pursued with equal vigour and enthusiasm by all at Myson Heating Controls over the next 21 years.

Contact: Sean Hanratty, Myson Heating Controls.

Tel: 069 - 62277; Fax: 069 - 62488.

email: enquiries@myson.ie

Product Range

- Thermostatic Radiator Valves
- Plastic Pipe Valves
- Morotised Valves
- Manual Valves
- Automatic By-pass Valves
- Combination Boiler Filling Loop
- Double-Check Valves
- Cylinder Stats
- Myson Electronic Programmers (1-circuit and 2-circuit)
- Programmable Room Stats
- Cylinder Stats

**IN-LINE DUCT FANS
VENT SERIES
CENTRIFUGAL FANS**

et al.: BS News



Sizes from 100 - 315 mm \varnothing

Airflow rates from 290 — 1890m³/hr

WIDE RANGE OF ACCESSORIES AVAILABLE

**CYLINDRICAL CASED AXIAL
FLOW FANS
TRB-TREB Series**



Sizes from 200 - 350 mm \varnothing

Airflow rates from 845 — 3070m³/hr

**"IN-LINE" AND "IN-WALL"
VERSIONS ARE AVAILABLE**

**ROOF MOUNTED FANS
MIXVENT— TH Series
Mixed Flow Fans**



Sizes from 150 — 315mm \varnothing

Airflow rates from 355 — 1725m³/hr

Two speed motors as standard, suitable for supply or extract
and for variable speed control

WIDE RANGE OF ACCESSORIES AVAILABLE



Fitzwilliam House
Industrial Estate
Blessington
Co Wicklow

*Call our Sales Team
TODAY*

Tel: 045 - 851 500

Fax: 045 - 851 501

Web: www.ventac.com

Email: sales@ventac.com

For full Ventac price list

email: mmoran@ventac.com

Systemair Goes Direct



Systemair, one of the world's leading HVAC manufacturers, has just opened its new dedicated sales and distribution centre in Dublin. Located at Unit 02 Furry Park, Santry, Dublin 9, Systemair (Ireland) Ltd offers basic product range items within 24 hours and all others within 72 hours from its central warehouse. Pictured above are Mark Russell, Area Sales Manager, with Raymond Graham, Sales Office Manager; Niall Horgan, Managing Director; and Anne Forrest, Administration/Order Processing. See also page 32 of this issue.

Construction Industry Committed to Recycling

"The Irish construction industry has targets to reduce construction and demolition waste by 85% over the next 13 years and the industry will put in a concerted effort to meet these ambitious targets", said Construction Industry Federation Director, Don O'Sullivan, at the inaugural meeting of the National Construction & Demolition Waste Council (NC&DWC last month.

"However", he went on, "it is unreasonable to expect the industry to shoulder all the costs of meeting these specific targets. While the industry accepts responsibility to ensure that waste generated must be minimised, it can only achieve this if all of the partners within the sector — including

clients, architects, engineers, material producers, suppliers, local authorities, Government and the entire building team — play their part".

According to Mr O'Sullivan, incentives are needed to help the industry develop more environmentally-friendly re-use, recycle and prevention methods. Financial resources from the Environmental Fund should be provided to fund initiatives and projects associated with C&D waste. Processing centres, transfer stations and basic re-cycling facilities will be necessary so that materials can be brought to one site for sorting and segregation. Skips which facilitate segregation of waste are also needed.

Ventac Motorised Automatic Swirl Diffusers

Traditionally, adjustable swirl diffusers are used in applications where, depending on ambient conditions, they may be required to supply cold or warm air at different times. As the supply air changes, the blade angle of the diffusers has to be adjusted in order to achieve the required comfort conditions within the occupied zone.

This would normally mean manually adjusting the blade angle which is time-consuming and often imprecise. However, Ventac now supplies an innovative range of Motorised Swirl Diffusers, together with duct and room temperature sensors and an ADT-1 controller, which automatically senses the room conditions and adjusts the diffusers to suit a cooling

or heating cycle.

The OD11-V diffusers are available in six sizes (from 200 to 630mm ø) and are capable of handling volume flow rates from 400 to 6,000m³/hr each. The



Ventac Motorised Automatic Swirl Diffusers.

ADT-1 controller can be used to control up to 10 units at any one time.

Contact: Ventac Sales Office.

Tel: 045 - 851500;

email: sales@ventac.com

Core has Carrier on Disc

Carrier Air Conditioning — which is currently celebrating its centenary year — now has a full electronic catalogue detailing its entire product portfolio, with all technical specifications and installation details.

Copies are available directly from Carrier's distributors in Ireland, Core Air Conditioning.

Contact: Austin McDermot/Andrew McEvitt, Core AC. Tel: 01 - 294 3110; email: infor@coreas.com



FÖHN

Oil or gas-fired high output cabinet
air heaters 30-415 kW

mark

et al.: BS News

**ECOFAN**

Recirculation/ventilation
destratification unit

Mark Éire BV, Coolea, Macroom, Co Cork.

Tel: 026 - 45334; Fax: 026 - 45383

INFRA LINE

Suspended flexible radiant
heating system 50-100 kW

INFRA

Suspended radiant heaters
12-32,4 kW

TANNER

Indirect hot water, steam or thermal oil
fueled air heater from 7.5-87 kW

ECOFAN

Reduces by recirculation the temperature
difference between the roof and the floor

ECOFAN

Reduces by recirculation the
temperature difference between
the roof and the floor

ROOFTOP

Direct gas-fired air heater, with atmospheric
burner and centrifugal fan; 20-370 kW,
bigger capacities are available on request

CALFLO

Direct gas-fired make up air heater,
with a fully modulating burner
with 100% efficiency; 71-996 kW

GS

Direct gas-fired air heater with
atmospheric burner and axial fan;
20.4-95.8 kW

GC

Direct gas-fired air heater with
atmospheric burner and centrifugal fan;
20.4-95.8 kW

G

Direct gas-fired duct heatexchanger
module with atmospheric burner;
20.4-95.8 kW

PIPE BENDER

The pipe bending machines bends
everything up to 4" both manually or
electrically operated machines available

INFRA AQUA

Flat radiant panels for ceiling suspension;
capacities are available on request

...not all VRF systems

Orbital Scroll Compression

- Scroll profiles separate to allow liquid refrigerant slugs to pass ensuring no damage
- Suction gas enters the scroll chamber not the sump ensuring no oil dilution
- Scroll tips utilise oil as the tip seal, not neoprene, to ensure reliability
- No thrust washers or springs required to force scroll tips to seal



Inverter Motor

- Unique stepless speed control, fully linear operation
- 30-115hz operation matching load requirements precisely
- High temperature motor design ensuring greater operating tolerance



Regional offices:

Kilkenny: 056 21310
Co. Cavan: 042 9665460
Limerick: 061 316797

ardline@vtr.com.net / bsn/vol41/iss7/1

Hitachi believe that truly inspirational design leads to the most innovative and effective product technologies, and an integral underpinning of the design and manufacturing procedure, is our belief in the need to protect the global environment. Performance, cost and environmental responsibility are not mutually exclusive considerations but rather a powerful combination.

That's why we invest over 6% of our total global sales turnover directly into research and development, with almost 17,000 of our 330,000 employees focused exclusively on the development of technologically advanced products, you can be sure Hitachi Air Conditioning will continue to lead where others follow - Hitachi Inspiration.

Hitachi VRF technology has been designed to fulfil the parameters of good system design; occupant comfort, ease of installation, speed of response, the ability to cope with evolving building layouts, and of course environmental considerations.

Systems are inverter.



Main Compressor Body

- Heavy steel construction acts as a noise muffler ensuring very quiet operation
- No oil pump required, differential gas pressure system utilised, resulting in greater reliability
- Compressor shell designed to act as effective oil separator
- Unique high-pressure design enables an oil less sump resulting in increased reliability

For example the unique Hitachi Pressure Scroll Compressor, fitted in the Set Free VRF range, meets the design criteria we set our engineers: reliability, performance and energy efficiency. The result...a linear controlled inverter, high-pressure scroll compressor, constant lubrication through differential pressure control, robust construction and only 5 moving parts.

A truly inspired design.

To find out more about the Hitachi High Pressure Scroll Compressor and our range of Set Free VRF systems (Heat Pump: 5,8,10,12,16,20HP and Heat Recovery: 8, 10HP) please contact your local Hitachi distributor to receive a catalogue or arrange a visit.

As we say, not all VRF systems are inverter; indeed not all inverter systems are the same.

For more information visit our website at www.hitachiaircon.com

HITACHI
Inspire the Next

Fläkt (Ireland) at Newlands

To celebrate the launch of their new company Fläkt (Ireland) Ltd recently hosted a golf outing for customers and staff at Newlands Golf Club. Over 50 consultants, mechanical contractors and staff took part in a stapleford competition, in what turned out to be one of the better days of summer. All had a great day and it has already been decided that the outing will continue to be an annual event. A range of prizes were presented in the usual categories after dinner.

Results are as follows.

Overall Winner
Pat Curley, Curley Smith Design

Runner-up
Colin Murphy, Homan O'Brien & Associates

Class 1:
1st Prize
Sammy Kerr, VMRA

2nd Prize
Noel Kelly, H.A O'Neill

3rd Prize
Michael White, EEL

Class 2:
1st Prize:
Derek Brogan, Curley Smith Design



Mark Grimes, Fläkt (Ireland), presenting overall winner Pat Curley, Curley Smith Design, with his prize.

2nd Prize:
Richard Flaherty, H.A.O.Neill

3rd Prize:
Tony Gannon, Cylon

Class 3:
1st Prize
Sean Flynn, OPW

2nd Prize
Paul Boylan, PKS

3rd Prize
Pat Barry, McCarrick Woods

Nearest The Pin:
George Francis, EEL

Staff Prize:
Robert Kenny, Fläkt (Ireland) Ltd.

Niels Due Jensen Retires from Grundfos

Grundfos CEO and Group President, Niels Due Jensen, will turn 60 in the spring of 2003 and, as a consequence, has decided to retire from his position. The Board of Directors of Grundfos Management A/S has appointed Executive Vice President, Jens Jørgen

Madsen as Group President and CEO of Grundfos Management A/S, effective from 1 January 2003.

He knows how to listen to customers as well as employees, he thinks strategically and acts accordingly and, most importantly, he represents

the values and the culture that have made Grundfos the world's leading pump manufacturer, says Mr Niels Due Jensen.

In his new position Mr Madsen will be responsible for a corporation with 11,000 staff around the world, working in 58 companies in 43 countries, and with a turnover of €1.36 billion in 2001.

Together with his wife, Mrs Minna Due Jensen, Mr Due Jensen will continue to work as an ambassador in relation to the Grundfos companies around the world where Mr and Mrs Due Jensen will focus on meeting the employees, hereby contributing to strengthening the Group's corporate culture which is so rich in tradition and has a unique set of values.

Since its establishment in February of this year, Fläkt (Ireland) has continued its long-running relationships with established customers, and carried over all brands that were previously associated with ABB. Products included are air handling units; fan coil units; air terminal devices; Dirivent warehousing systems; and Climaveneta chillers.

Woods Fans have been added to the portfolio. Fläkt's relationship with its two main business partners — Cylon and Siemens — have continued.

Fläkt (Ireland) Ltd continues to trade from its existing headquarters at Belgard Road, Tallaght, Dublin 24, and currently employs 35 people.



Outgoing Grundfos CEO and Group President, Niels Due Jensen



Jens Jørgen Madsen, who will take over as Group President and CEO of Grundfos Management A/S from January 2003.



AquaStream²

The Ultimate in technology and simplicity.



The new AquaStream²® range of liquid chillers and reversible units from Trane provides:

- The proven reliability of TRANE Scroll Compressors
- HFC R407C refrigerant
- Low Noise Levels
- Extra low noise option for sensitive areas
- Integral hydraulic module
- Simple installation

The integral hydraulic module saves design time, saves space and saves installation time - and has the benefits of single source supply. Simply connect to water supply and electrical mains and start.

With a wide capacity range from 50 to 250 kW, AquaStream²® provides the answer for most applications.

Simply, efficiently, reliably, environmentally and economically.

To receive full documentation on our new AquaStream²® range,

CONTACT TRANE IRELAND TEL : 01 4606030
FAX : 01 4606039



TRANE[®]
AIR CONDITIONING

BE > THINK > INNOVATE >

DON'T REPLACE

A TRADITIONAL PUMP

NOT JUST A PUMP – A NEW STANDARD

Grundfos Alpha is something of a revolution. A major breakthrough in automatic controlled circulators. A pump that pumps when necessary – otherwise not. Some call it intelligent. We call it reduced power consumption, a better environment, less radiator noise, faster installation. Get ready for a new standard!





UPGRADE

TO A COMPLETELY SILENT MODEL

Fantech Launches Domestic & Commercial Ranges

Fantech Ventilation has introduced a comprehensive new range of Elta domestic and commercial fans. With ten categories and more than 100 different product variations, the domestic and commercial range boasts a number of innovations, including a collection of slim profile axial and centrifugal fans. Fantech's Managing Director Brendan O'Toole

correct selection and application of Elta products can resolve such problems and substantially improve air quality."

The Domestic and Commercial range incorporates a selection of SA axial and SC centrifugal fans suitable for toilets, bathrooms, utility rooms and kitchens. Both have standard, low voltage and

Elta has also developed a new commercial axial range — SAX — for applications where new-build, refurbishment or replacement fans are required, such as offices, pubs, restaurants, shops or leisure centres. Their high performance rates make SAX fans extremely cost effective for installations where previously two or more fans would have been



Fantech Ventilation stocks a complete range of Elta commercial and domestic fans.

says: "This new range provides outstanding quality while maintaining value for money. It features fans developed specifically for a host of domestic and commercial applications, from bathrooms, toilets and utility rooms, to sports halls, public houses and offices.

"Inadequate ventilation can result in dampness, condensation and stale or unpleasant odours. Over time, it can also contribute to a building's deterioration and create health problems for the occupants. We believe the

executive options, the latter meeting particularly high standards in aesthetic design with a minimum protrusion of just 8mm on the axial model and 19mm on the centrifugal model — an industry first, according to Elta.

Fans are quiet in operation and come with unique features to make installation and maintenance easier, including locking rings for ceiling mounting on SA units and side removable access plates for ease of wiring on SC fans.

required and, in some cases, can facilitate compliance with the leisure and hospitality industry's self-regulatory Public Places Charter on smoking.

SAX fans are designed for installation into windows, panels and ceilings, as well as solid or cavity walls. They are available in two standard sizes with 9" and 12" fans giving duties from 824 m³/h up to 1,900 m³/h.

Completing the range are: — Elta's SPE industrial wall fans, which provide effective

ventilation for more demanding applications including gymnasiums and squash courts; — SM and SMT in duct units designed to be installed with rigid or flexible ducting and provide the necessary pressure development to overcome resistance of many ducted applications; — SJ in-line centrifugal fans, for installations where increased pressure development to overcome resistance is needed, and SH in-line centrifugal boxed fans, designed for internal use where space is at a premium and low breakout noise is required;

— SMF 'Miniflow' axial roof extract units developed to provide roof extract for small to medium sized rooms including domestic bathrooms, offices and changing rooms;

Brendan O'Toole says: "To make product selection quicker and easier we have allocated every domestic and commercial product in the catalogue a 'Selection Symbol'. The symbol represents a particular application or characteristic of the product so it is instantly recognisable for the user."

The entire range is available ex-stock in Dublin.

Contact: Brendan O'Toole, Fantech Ventilation. Tel: 01- 882 8411; Mobile: 087 2572099; email: Fantech@circom.net

Fans

Dampers

Diffusers

Grilles

Ductwork

Fantech
VENTILATION

Tel: 01 882 8411 Fax: 01 882 8412
 BRENDAN O'TOOLE DAVE CONNELL
 0872 572099 0879 198388

"Knowledge in Ventilation"

Unit 13, Tolka Valley Business Park, Ballyboggin Road, Dublin 11
 fantech@eircom.net www.fantechventilation.com

Space Heating & Building
Temperature Control Solutions
From One Source

AMBIRAD

heatmiser™
Effective Temperature Control

For complete catalogue information, technical support,
or for an immediate quotation contact:

Thermelec Ltd, Old Naas Road, Bluebell, Dublin 12
 Tel: 01 - 456 8111; Fax: 01 - 456 8108; email: sales@thermelec.ie

THERMELEC

Air Conditioning 100 Years Old!

As sweltering temperatures roast the USA from coast to coast, Americans — and people across the entire world — are thankful that 100 years ago Dr Willis H. Carrier invented modern air conditioning. On July 17, 1902, the gifted young engineer's invention — encompassing the first system to provide man-made control over temperature, humidity, ventilation and air quality — was first designed as a solution to the quality problems experienced at a Brooklyn printing plant.

It not only spawned a company and an industry, but also brought about profound economic, social and cultural changes. By the end of the 20th century, 80% of US homes were air conditioned.

Perhaps the most dramatic impact of air conditioning has been in previously "inhospitable" climates.

Carrier Corporation, which today still bears its founder's name, is the industry leader, having manufactured some 100 million air conditioning units in the past 100 years. Carrier Corporation is



heralding the 100th anniversary with a celebration designed to achieve widespread recognition for its founder — an "unsung hero."

"Despite the immense impact of air conditioning on humankind, Willis Carrier is still surprisingly unknown," said Austin McDermot of Irish distributors Core Air Conditioning. "Carrier believes he should rightfully be viewed by historians and the public as one of the world's greatest inventors."

To honour its founder, Carrier Corporation is partnering with the New York City Board of Education to establish The Willis H. Carrier Academy at Brooklyn's W.E. Grady Technical High School. Carrier Corporation is donating funds to the Board of Education to purchase equipment and renovate classroom space at Grady devoted to the Willis H. Carrier Academy. The Academy's faculty will have access to Carrier's training programme. In addition, Carrier will host student groups at its facilities.

Aircontec to Return to ISH

Representatives of major companies in the air conditioning and ventilation industry have officially informed Messe Frankfurt that, in the future, they would like to exhibit at the ISH again. In 2000, the industry moved from the ISH to the new Light + Building — International Trade Fair for Architecture and Technology — to make their presentations in association with house and building automation, as well as electrical and engineering and lighting.

Four years ago, integrating the industry

into Light + Building appeared to be the best possible solution. However, the planners and fitters who plan and install not only heating but also air-conditioning and ventilation systems, continue to see the ISH as being the most important fair for them.

Thus, since the end of Light + Building 2002, the consensus of opinion has been that air-conditioning and ventilation technology should return to the ISH under the Aircontec brand name. This will now happen at 2003.

Dublin Wastewater Treatment Most Advanced in the World

Dublin is set to have the most advanced wastewater treatment system in the world when the €300 million Dublin Bay Project is up and running in less than six months time.

The Dublin Bay Project consists of a new pumping station at Sutton which will be completed in October. Final alignment of the 10.5km pipeline under Dublin Bay is underway and the hi-tech wastewater treatment plant at Ringsend is due to be completed in December. Wastewater from the Northside will be pumped from Sutton Pumping Station, via the submarine pipeline under the Bay, across to Ringsend for treatment.

The Treatment Works at Ringsend will provide primary, secondary and tertiary treatment for wastewater (rainwater, sewage and effluent from factories) to create three products — Biofert, a high-grade agricultural fertiliser; Biogas to supply 60% of the plant's energy needs; and clean water in Dublin Bay.

The mammoth project, managed by Dublin City Council, is financed by the EU Cohesion Fund and the National Development Plan.

THE HONEYWELL ENTERPRISE BUILDINGS INTEGRATOR™

**LIFESAFETY
MANAGEMENT**

**SECURITY
MANAGEMENT**

**BUILDING
MANAGEMENT**



ADVANCING PRODUCTIVITY AND EFFICIENCY ACROSS YOUR ENTERPRISE

Decisions that can effectively improve the safety, security and productivity of your total enterprise, depend on the quality of information available and the speed at which it can be accessed.

The need to protect assets, see trends, analyse data, put realtime and historical information into perspective and reduce costs, places an ever increasing demand on facility management teams.

Now Honeywell provides the total solution – The Enterprise Buildings Integrator™ system.

The EBI system pulls together all core building systems and integrates information from many

different enterprise subsystems, to provide quality information that can lead to more cost-effective solutions to critical decisions – faster.

The Honeywell EBI system provides a powerful window into your entire operation – enabling you to boost productivity, improve safety standards, maximise assets and drive down costs.

Invest in the future for your organisation, call 0044 1344 656000 NOW for more details. Or write to Honeywell Control Systems Ltd, Honeywell House, Arlington Business Park, Bracknell, Berkshire RG12 1EB.

Honeywell



Systemair

The Straight Way



delivery reliability underpin these strengths, with customer confidence further boosted by the assured top-quality service at all times. Systemair also has a comprehensive education programme. The Systemair Academy is a training programme which is run a number of times a year in Sweden for both the company's own staff and customers.

During the year a number of Irish customers are expected to attend the Academy where they will learn about Systemair and its products. Systemair offers the most comprehensive range of ventilation equipment for the Irish market. A copy of the new 500-page catalogue is available on request. Brief details illustrating the scope of the range are as follows:

Systemair, one of the world's largest HVAC manufacturers, has just opened its new sales and distribution centre in Dublin. Located in Santry, Systemair will deliver its basic product range within 24 hours and any products not in stock will be delivered within 72 hours from a central warehouse. There is also a 3-year guarantee on all products within the range. Systemair is a group of 32 companies located in Europe, North America and Asia and with headquarters in Sweden. Production facilities are located in Sweden, Norway, Denmark, Germany and Canada and

the total production surface area is over 60,000 sq m. It employs over 1,000 people worldwide. The automated sheet metal production facility in Sweden is one of the most modern in Northern Europe. Due to the high level of inward investment by the group, similar automated production lines are being installed in all production facilities. This further increases the capacity and productivity of the group. With its easy-to-use product catalogues and electronic selection programmes, Systemair offers customers a reliable and professional service. Good product design and

Contact:

Niall Horgan, Managing Director. email: niho@systemair.ie

Mark Russell, Area Sales Manager. email: maru@systemair.ie

Raymond Graham, Sales Office Manager. email: ragr@systemair.ie

Anne Forrest, Administration/Order Processing. email: anfo@systemair.ie

Tel: 01-8624544; Fax: 01-8628030

<https://arrow.tudublin.ie/bsn/vol41/iss7/1>

Square Duct Fans

MUB – A plug fan in a sound-absorbing casing suitable for multiple airflow directions
Maximum duty
16,000m³/hr vs 1,100 Pa.



Ancillaries

Attenuators, filter boxes, clamps, mounting brackets, flexible connectors, iris dampers, back draft shutters etc.

Kitchen Extract Fans

KBT/KBR – A forward and backward curved blade with 50mm insulation and a hinged access door. Maximum duty 7,000m³/hr vs 2,400 Pa

Roof Fans

DHS/DVS – A centrifugal roof fan in an aluminium casing and a maximum duty of 16,250m³/hr vs 550 Pa;



DVSI – As above however with a sound-absorbing cover;
DVN – A high temperature roof extract fan up to 120°C. Maximum duty 36,500m³/hr vs 850 Pa;
DVNI – With a sound-absorbing cover;
DVV – A smoke extract fan rated for 400°C for 2 hours and 600°C for 2 hours. Maximum duty 45,000 m³/hr vs 1,400 Pa



Air Terminal Devices

Sinus, Elegant, SPI, EFF, TFF – A wide range of supply and extract grilles.

Air Handling Units

All units are manufactured using a solid metal framing system with double walled panels complete with heavy 50mm layer of mineral fibre. Maximum duty 200,000m³/hr vs 10,000Pa.



Circular Fans

K type – A galvanized steel-cased fan with a maximum duty of 1,700m³/hr vs 700 Pa; RVK type – Plastic casing same performance as above; KD type – A mixed-flow impeller with a powder-coated steel casing and a maximum 8,500m³/hr vs 530 Pa; KVK type – In a metal sound absorbing casing and a maximum duty of 2,600m³/hr vs 390 Pa; KVKF/KVO type – A compact design in a sound-absorbing casing. Maximum duty 2,700 m³/hr vs 430 Pa;

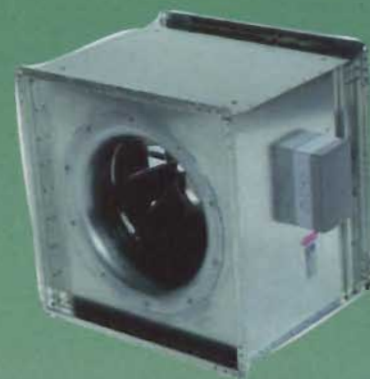

KVKE type – A backward curved impeller in a sound absorbing casing. Maximum duty 2,200m³/hr vs 1,000 Pa.

Rectangular Duct Fans

KE/KT type – A forward curved impeller fan with a maximum duty of 8,900m³/hr vs 1,100 Pa; RS type – A backward curved impeller with a swing out door. Maximum duty 13,600m³/hr vs 850 Pa; RSI type – A backward curved impeller with a sound-absorbing casing and a swing out door. Maximum duty 13,600 m³/hr vs 850 Pa



Heat Recovery Units

Rotovex – A modular heat recovery unit with a rotary heat exchanger and electronic controls. Maximum duty 5,200m³/hr; VX,VM,MAXI – A 90% efficient heat recovery unit complete with a plate heat exchanger. Maximum duty 4,000 m³/hr.

Heating Products

Electric Heater Batteries – Both circular and rectangular with a maximum duty of 75 kw. Door Curtains – Recessed and surface mounted door curtains for industrial and commercial use.



Speed Controllers

RE, RTRD, MTY, RDT ... Both electronic and transformer type speed controllers.

Systemair (Ireland) Ltd, Unit 02 Furry Park, Santry, Dublin 9.
Tel: 01-8624544; Fax: 01-8628030; Web: www.systemair.com

Sanyo's First W-Eco installation in Ireland

Elverys Sports are a quality sports retail chain with approximately 40 stores around the country. The air conditioning solution for the large Fonthill Road store offers over 180kw of outdoor

excellent." "Sanyo is the fastest-growing Japanese manufacturer of air conditioners and enjoys major brand status in Europe", says Barry Hennessy, who heads up



Interior of the new Elverys superstore in Fonthill Road in Dublin.

capacity utilising the Sanyo 20hp W-Eco units combined with 10hp add units. The indoor units used were Sanyo UR above-ceiling ducted units.

Alan Carson, Managing Director of CFC Refrigeration, and an established Sanyo customer, was the contractor for the project and explains why Sanyo was the preferred choice. "We have been impressed with the flexibility of Sanyo's range using the same indoor units for VRF and split system installations and their strong service record. With Sanyo you know you can rely on the quality and their support at design and commissioning stage is

Sanyo's Irish operation. "In response to strong growth in Ireland its new direct sales operation based in Dublin was set up earlier this year. The solution for the high

street store is based upon a higher duty of indoor units to outdoor units. This diversity ensures that the client gains maximum energy efficiency from the system. This is typical of Sanyo, which, as a multinational manufacturer, takes a responsible attitude towards environmental issues. We were delighted to work with CFC Refrigeration on this project as Sanyo units are remarkably quiet making them ideal for use in a retail environment."

The units themselves had significant benefits from Alan's point of view. "Because the indoor units come with prefitted discharge spigots, the UR units made the installation quick and simple." He continues. "Sanyo units also come with lift pump as standard, simplifying condensate removal and keeping costs down."

Sanyo Ireland's Sales Manager, Barry Hennessy worked closely with Alan

and his team throughout the design and installation.

Contact: Barry Hennessy, Sanyo Air Conditioners.
Tel: 01 - 456 8910;
Web: www.sanyoaircon.com

Rice Appointed RECI Chairman

Jim Rice has been appointed Chairman of the Register of Electrical Contractors of Ireland. He has been an active board member since 1996 and has contributed to the development of RECI during its formative years.



Jim is currently General Manager of Schneider Electric Ireland, based in Celbridge, Co Kildare. He is a past Chairman of the Electro-Technical Council of Ireland (ETCI) and is currently Chairman of the ETCI Switchgear Committee TC4.



The Sanyo W Eco multi outdoor units serving the UR ducted indoor units at Elverys new superstore in Dublin.



There are fittings . . .

**Don't settle for cheap imitations
that leave you knee deep
just when you least expect it!**

**Conex is the established brand name
for quality that plumbers know and trust!**

**So when it comes to quality
just ask for Conex.**

The name for quality fittings!

then there's
CONEX

THE NAME FOR QUALITY TRIFLOW SOLDER RING AND COMPRESSION FITTINGS



Ireland's No. 1 Service Provider

Muirfield Drive, Naas Road, Dublin 12. Tel: (353) 01 - 419 1919. Fax: (353) 01 - 458 4806. email: karlc@hevac.ie

Furry Park, Santry, Dublin 9. Tel: (353) 01 - 842 7037. Fax: (353) 01 - 842 7045

South Ring West Business Park, Cork. Tel: (353) 021 - 432 1066. Fax: (353) 021 - 432 1068.

Hitachi Unveils Radical Distribution Shake-up

To underpin its aggressive growth plans in Ireland, Hitachi Europe Ltd has announced a very significant development in its sales channel strategy. With immediate effect, Ardline Aircon Ltd will distribute the full range of Hitachi split system air conditioning products throughout Ireland. The directors of Ardline Aircon have extensive experience

Ltd to the Hitachi family and are confident that our two great names will bring technology, efficiency, quality and customer support directly to the market."

In his response to the announcement of the new agreement, John Brogan, Chairman for Ardline Aircon Ltd, was equally enthusiastic: "It was time to re-evaluate our product offering and Ardline has

together of a number of Irish-owned refrigeration companies with a combined turnover in excess of €20 million. "The Group Arrangement," John Ryan, Managing Director for Ardline Group Holdings, explains: "allows us to maximise buying power and

technical resources and to provide a comprehensive service to clients with a multi-location operating network."

Contact: Ardline Aircon Ltd.
Kilkenny: 056 - 21310;
Cavan: 042 - 9665460;
Limerick: 061 - 316797
email: ardline@eircom.net



working with major air conditioning brands in Ireland over the past 15 years.

In commenting on the agreement, Des Kinsella, European Sales and Marketing Manager for Hitachi Air Conditioning, stressed the significance of the move: "Hitachi offers a much-expanded and improved product range, from single split inverter models with R410A, a full range of R407C premium brand heat pump and cooling only Utopia range, and of course our advanced engineering R407C 2 and 3-pipe VRF offering. These products — now allied to the strength and commitment of Ardline — will greatly enhance our position in the market place.

"We are pleased to welcome Ardline Aircon

taken the time to survey the marketplace and what is on offer to the customer. We identified the real added value that a truly premium brand brings, and also of course the need for that product to be supported by a strong and reliable distribution network. In Hitachi we have found an opportunity to realise a number of synergies which will ultimately benefit our customers. Nobody will be surprised with the quality and reliability of Hitachi equipment, but what may pleasantly surprise many is the extensive Hitachi range, the advanced features, the on-board technology and of course the competitive prices." Ardline Aircon Ltd, a subsidiary of the Ardline Group Holdings, represents the coming

Rapid-Response Temperature Humidity Transmitter

Dwyer Series HU Temperature/Humidity Transmitter from Manotherm offers quick-response, stable, repeatable and accurate ($\pm 2\%$) temperature and humidity readings.

Operating temperature range for the unit is -30 to 130°F (-35 to 55°C). Relative humidity range is 0-100% RH. The

transmitter's 4 to 20 mA output signal is fully conditioned and temperature compensated.

Employing a polymer capacitance sensor, this transmitter is available for duct mounting in a NEMA 4 (IP56) cold-rolled steel enclosure. Humidity-only models are also available, either with the steel enclosure for duct mounting or with an ABS plastic enclosure for wall mounting.

All models feature non-interacting zero and span adjustments ($\pm 15\%$) and short circuit and reverse polarity protection. Duct-mount models weigh 1.0lbs (.45kg). The wall-mount model weighs 0.5lbs (.25kg). All models are available ex-stock.

Contact: Bob Gilbert/Brian Harris, Manotherm.
Tel: 01 - 452 2355; email: manotherm@eircom.net



Dwyer Series HU rapid-response temperature/humidity transmitter from Manotherm.

Trane Close Control

Trane's range of precision air-conditioning units are specifically designed to provide advanced, reliable technological solutions for high specification clean rooms, laboratories, telecommunication centres, and internet sites. Trane Mercury and Jupiter Precision AC units

and Eurovent standards.

In this high-tech, high-specification market sector, it is critical to keep ahead of market needs and changes through continuous product development. That is why 5% of the sales turnover is invested into research and development, and over 800m² has been dedicated to laboratories and test rooms. In addition, Trane can simulate design operating conditions for internet and telecom centres in a purpose-built test facility.

Supplying over 90 telecom companies worldwide, Trane's precision air conditioning units are well reputed for their quality and reliability. Its confidence in the range is such that the

company offers a 3-year parts warranty on all Mercury and Jupiter units.

Compact, modular and equipped with different microprocessor systems selected to suit the application, Trane systems can be configured and re-configured as required to suit changing capacities, building layouts, and client demands.

Contact: Trane Ireland.
Tel: 01 - 460 6030;
Web: www.trane.com

Drying and Heating Equipment From Mark Eire

Mark Eire designs, manufactures, installs and commissions a wide range of process drying and process heating equipment suitable for the food industry. Foodstuff products that can be dried by Mark equipment include milk powder, cereal products, breadcrumbs, chocolate granules, nuts, rice and soya products. In addition to the food industry, the company also supplies equipment to the pharmaceutical, chemical and waste industries enabling drugs, chemicals and by-products, ferris sulphate polymers, paints, sludge, animal waste and meat scraps to be dried. Aggregate materials such as gravel and granules and powder-cement, clay, metal parts and castings can also be handled.

All these systems are custom built and employ one or more of the following: fluidised beds; spray driers; ovens; drums; conveyor lines; cyclone and hopper.

Mark Eire adopts an integrated approach in designing such systems involving product, process, environment and company objectives.

Contact: Paraic O'Conaola, Mark Eire BV.
Tel: 026 - 45334; email: poconaola@markeire.com



Mark Eire drying and heating system are custom-built to meet specific needs

Trane's precision air conditioning units are specifically designed to provide advanced, reliable technological solutions for all manner of high-specification applications

are available in upflow and downflow configurations with either DX or chilled water cooling. The option of air or water cooled condensing units provides the complete solution. All Trane units are manufactured to ISO

Stealth Pump from Wilo

Wilo Engineering has available a range of "stealth" pumps that are up to 20dB(A) quieter than pumps with traditional fan-ventilated motors. The latest centrifugal multi-stage pumps are ideal for boosting water in buildings where noise may be an issue. Typical examples include hotels, libraries, museums, theatres, and other public areas.

Known as the Wilo-Multivert MVIS series, the high pressure centrifugal pumps have no noisy fans to

keep their motors cool. Instead, the shaft and bearings are constantly exposed to — and cooled by — the water they are pumping. This type of wet rotor design not only removes the need for a noisy fan but is also an extremely efficient means of cooling the motor. Unlike some other low noise pumps, the Wilo-Multivert MVIS series can be mounted vertically. As a result, it is easy to install MVIS series pumps wherever it is most convenient and efficient.

"Maintenance free" has been a guiding principle in the development of the Wilo-Multivert MVIS series. The pumps

are ruggedly constructed with stainless steel impellers, diffusers and pressure casings, and the wet rotor design — with a single shaft for both motor and pump — is effectively "sealed for life". Also, there are none of the external moving parts normally associated with fan-cooled motors.

The Wilo-Multivert MVIS series boasts a flow rate up to 14m³ per hour and up to 110m head. The pumps are available in three ranges — the MVIS 200, MVIS 400 and MVIS 800 — and can be supplied with either the standard female threaded or Victaulic connections.

Contact: Wilo Engineering, Tel: 061 - 410 963; e-mail: sales@wilo.ie Web: www.wilo.ie



The "Stealth" pump from Wilo combines high pressure with minimum noise.

Lennox Slimline Fan Coil Units

Lennox has launched a new slimline range of fan coil units called the Compact Slimline Waterside. Three units are available across the range — the WSL 300; WSL 500; and WSL 800. Each model stands 172mm tall and 773mm long, with lengths of 604mm, 1104mm and 1604mm respectively.

While each comes in a condensed size, the Compact Slimline Waterside includes separate heating and cooling coils, coils for low and high water temperatures, electrical enclosure housing valve controls, optional condensate pump kit, electrical mains lead (two metres) and plug, as well as a filter to EU2 specifications.

Additional features are:

- low noise, high performance single inlet, single width fans;
- coils manufactured using solid drawn copper tubes and aluminum fins;
- casing consisting of durable 1.2mm (18 gauge) galvanised steel reinforced to form a rigid monoque construction;
- discharge plenum wholly lined with Class 0 acoustic insulation;
- a fully insulated drip tray designed such that pools of water cannot form;
- a total of 27 speed options.

Contact: Philip McEvitt, Airconditioning Technology Ltd. Tel: 01 - 820 5590; email: aircond@iol.ie

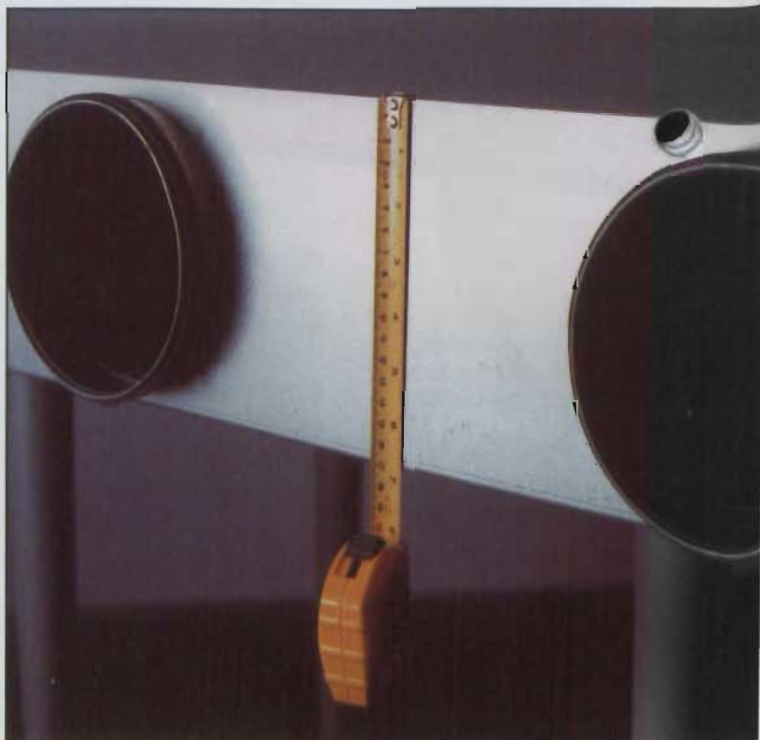

The new Lennox Compact Slimline Waterside fan coil unit from Airconditioning Technology.

Sirrus & Siemens At Mount Juliet

Sirrus and Siemens hosted a corporate day for customers and their guests at Mount Juliet recently. The occasion proved extremely successful, the beautiful grounds, excellent golf course and additional sports facilities such as shooting, archery, the swimming pool and gym ensuring that everyone had a multiple choice of activities to choose from.

As always though, the golf dominated. Winners on the day were as follows:

- First** — Mark Poland, UCC with 36pts;
- Second** — Martin McSherry, McCarrick Woods with 36pts;
- Third** — Tony Crocock, FCM with 34pts.
- Longest Drive** — Peter Ryan, SEHB;
- Best Back Nine** — Billy Matthews, Bausch & Lomb
- Nearest the pin** — Peter O'Shea, HA O'Neill.
- Archery Winner** — Ken McIlhenny, McCarrick Wood.
- Shooting** — Sean McGuinness, Jacobs Engineering.



Peter Hoyle, Sales Director, Siemens Fire Safety presenting overall winner Mark Poland, UCC, with his prize. Also in the picture is James Byrne, Managing Director, Sirrus Engineering Systems.



Peter Hoyle with Peter Ryan, SEHB, winner of longest drive, with James Byrne.



Peter Hoyle with nearest the pin winner Peter O'Shea, HA O'Neill and James Byrne.



Peter Moyle with James Byrne and Billy Matthews, winner, best back nine.

Get Specified

Realise Decent Profit Margins

Get Listed In the Specifier's
Purchasing BIBLE

Advertise in the
BSNews Buyer Guide 2003/4

Contact Joe Warren
Tel: 01 - 288 5001

Email: joe@pressline.ie

The sun has been the source of energy and life on earth since the beginning of time. It is, in effect, a huge nuclear reactor at 6,000 °C that provides our planet with heat and light. Today, solar energy can provide cost-effective solutions to fight climate change and reduce our dependency on expensive and polluting fuels, writes Paul Dykes, Marketing Manager Renewable Energy Information Office:

Solar energy in Ireland is not a myth, and contrary to what many people may think, we are not short of solar energy resources.

At current energy prices the average Irish family will spend over €40,000 in the next 30 years to heat their homes. Reducing that bill by 50% can be achieved cost-effectively by harnessing energy from the sun. The sun is a very intense source of free, eco-friendly energy that will always be available. Moreover, it is carbon dioxide (the main greenhouse gas) free, and will never send a bill!

Passive solar design is an architectural approach that seeks to maximise solar gains, reduce heat losses and provide natural day-lighting and ventilation. The key elements of a passive solar building are south-facing orientation, a high level of insulation, a comparatively large area of glazing on the south facade, controlled ventilation, shading to avoid overheating and wind sheltering.

Active solar thermal heating is a mature technology for space and, more commonly, water

heating. Currently it is used by over 2.5 million households across Europe and increasing number of families across Ireland have opted for solar water heaters to cover a large proportion of their heating requirements. In

combines space heating and domestic hot water production. A so-called solar combi-system can cost between €8,000 and €10,000 and reduce the total heating and hot water bill by 40%.

A renewable energy

THE SUN WILL NEVER SEND A BILL!

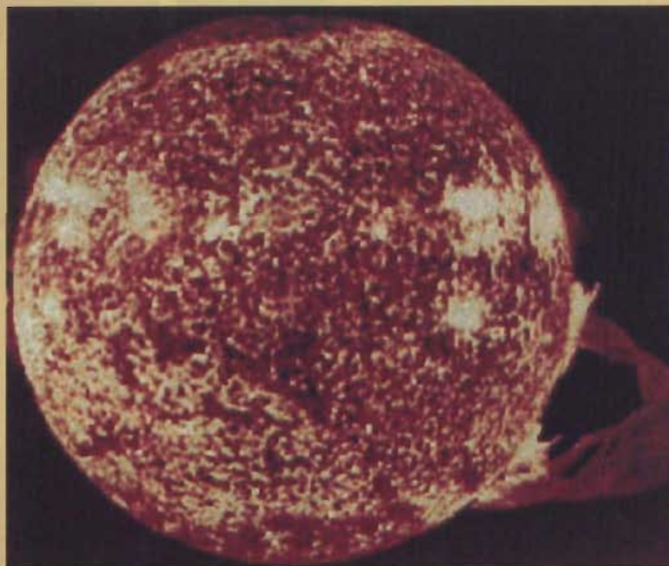

2001, a network of professional installers in Ireland installed nearly 200 solar water or air heaters and that trend is continuing this year.

High quality products are now available, solar systems are reliable and their productivity can be guaranteed. For an investment of between €3,000 and €5,000, a solar water heater will effectively reduce the average hot water bill by over 50%.

Solar thermal collectors can also be used in a larger system that

heat pump extracts ambient heat from low temperature sources (ground, air and water), upgrades it to a useful level of temperature, and releases it when and where required. These ambient heat sources are available in very large quantities all around us and are constantly replenished by the sun, rain and wind. Electricity is required to drive the heat pump. However, for every unit of electricity used it will generate three to five units of useful heat.

In both domestic and

commercial buildings, energy demand is dominated by heating requirements – ground source heat pumps are one of the most efficient ways to heat and cool buildings and provide hot water. This well-established technology offers benefits for all, including a healthier and more comfortable working and living environment; reduced energy consumption; and financial savings of up to 70% on energy bills and maintenance costs.

In larger buildings, individual heat pumps can be placed and used in different areas, each sized to meet the needs of the area it serves. Providing the installed system is fully integrated, the heat pump system can recover excess heat in one area (computer rooms for example) and transfer it via a pipe loop to those areas of the building requiring heating. On those occasions when demand for heat exceeds the available reclaimed energy, a ground source heat pump can supply the central loop with heat from the ground underneath or around the building.

The same heat pump can, in reverse, extract excess heat from the central loop and store it in the ground for use at a later stage.

Renewable heat pumps are a mature technology that have proved their financial and environmental benefits around the world, with close on 100 million heat pumps now installed in commercial buildings.

Contact: Paul Dykes, Renewable Energy Information Office. Tel: 023 42193; email: renewables@reio.ie

Malahide 20 June

Sponsor: Dublin Providers

Overall Winner	Jim Bollard	(20)	35.5 Points
2nd Overall Winner	Mick Matthews	(7)	35 Points
Class 1	1-12		
	1 Des Prendergast	(8)	31 Points
	2 Eamonn Walsh	(11)	31 Points
	3 Brendan Keaveny	(6)	30 Points
Class 2	13-18		
	1 Jim Nolan	(13)	34 Points
	2 Dave Cranston	(14)	30.5 Points
	3 Vincent Broderick	(13)	30 Points
Class 3	19-28		
	1 John Duignan	(24)	33 Points
	2 Gerry Tobin	(16)	30 Points
	3 Noel McKeon	(16)	30 Points
Front 9	Jerry Maher		
Back 9	Eamonn Vickers		
Visitor	Pat Maher		



Old Conna: Overall winner Graham Fay receiving his prize from BTU Captain Des Prendergast.



John Lavelle receiving the "Past Captains" prize from Michael Murphy, Fläkt Ireland, who sponsored the Old Conna outing.

Old Conna 12 July

Sponsor: Fläkt Irl Ltd

Overall Winner	Graham Fay	(7)	41 Points
Class 1	0-11		
	1 Shay Kearney	(10)	38 Points
	2 Pat Gormley	(5)	37 Points
	3 Mick Matthews	(8)	35 Points
Class 2	12-15		
	1 Eamonn Walsh	(12)	40 Points
	2 Brian Keaveny	(14)	38 Points
	3 Jim Smith	(14)	38 Points
Class 3	16-28		
	1 John Ennis	(16)	36 Points
	2 Tom Scott	(19)	34 Points
	3 Niall Ryan	(20)	34 Points
Visitors	Brendan Burke	(9)	41 Points
	Dick Gleeson	(12)	35 Points
Past Captain's	John Lavelle		33 Points
Longest Drive	John White		
Nearest Pin	Bernard Sweeney		
Front 9	Dave Harris	(20)	
Back 9	Gerry Phelan		
Next Outing	BTU Weekend		31 August
President's Prizes	Trim		13 September



Sinking Funds and Reserve Provisions



Peter Birthistle, FCA,
Finance Director
with Irish Estates,
Ireland's largest
Property and Facilities
Management Company.
Tel: 01 - 704 1400

How do you allow for the considerable expenditure involved in the refurbishment and replacement of building and plant?

There is nothing new in this question but the frequency of this question being asked by both landlord and tenant alike has increased due to the rising costs of building in general and related new plant and equipment. The most usual methods are the creation of either Sinking Funds or Reserve Provisions.

Sinking Funds and Reserve Provision have been in existence in one form or another since the advent of formal leases. There has always been the understanding that provision is required for the replacement or refurbishment on expenditure on large items of plant and equipment and building fabric.

The terms sinking fund and reserve provision are often used to describe the same thing but they are different.

A sinking fund is set up for the replacement or refurbishment of specific assets and can only be used for this purpose.

In the case of a reserve provision this is a general fund which can be used to cover any major works that fall outside of the normal service charge type items.

Most leases will stipulate which fund is to operate and what is covered by the fund, thereby determining whether it is a sinking fund or reserve provision. Please be aware that whether there is a specific clause in the lease or not the obligation usually exists to "repair and keep in good and substantial repair and condition the demised premises". This also includes rebuilding, renewing or reinstating all or part of the demised premises.

A lot of leases, while silent on either funds or reserve provisions, give the landlord a discretionary right to operate to "best estate management practices" and to incur any

reasonable expenditure on the property. This could, depending on the specific wording and content of the lease, be used to build up funds or for the purpose of providing for major works required in the future.

If there is no fund or reserve provision in place, the cost of replacement will either be charged in one lump sum through the service charge and the tenants will become liable forthwith, or some form of financing may be put in place. Any financing would then be charged to the tenants over the period of the facility.

Obviously, the first of these two approaches causes major problems for tenants, as they will be required to pay the unanticipated charge in one lump sum.

The second, which will still cause hardship, is at least charged over a few years. It is also more expensive as there will be a financing facility cost. Further, there is the problem of raising the finance — the lenders may wish the facility to be secured and an issue may arise regarding who is prepared to offer this security.

The setting up of sinking funds and reserve provisions ensures funds are accumulated in advance to cover these major items of expenditure as they arise. These funds should be managed and accounted for independently of the annual service charge. In some cases the lease stipulates that the sinking fund or reserve provision is to

be audited separately each year. These funds, once received, can be put on deposit to earn interest, which should be added back into the fund. This approach reduces the potential for large increases in charges in any one particular year.

Tenants' resistance to building up funds of this nature, even if they are specifically mentioned in the wording of the lease, stems from a belief that they may not be tenants when the property's equipment needs major refurbishment or replacement and therefore would never benefit from the new equipment. There is also the opinion that, depending on the business and financial strength of the tenants, they will fund the expenditure as and

funds raised for either a sinking fund or a reserve provision are an asset of the property and, if the property is sold, the balance in the fund should transfer with the property.

The benefits to both the tenants and the landlords of having a fund in place is that it can aid in assigning a lease to new tenants' as it reduces the new tenants potential exposure. It is not unusual for value consideration to be given to the assignor by the assignee for their contributions to the fund to the date of transfer.

For the landlord the situation is the same. Should new tenants feel that major refurbishment is required to the building, their concerns may be allayed if there is already a fund in place for

The life expectancy or major pieces of plant and equipment vary depending on the particular item in question. Examples being 15 years in the case of boilers to 25 years for lifts. The expected useful life of any piece of plant and equipment and building fabric can be further influenced by:

- Type and level of maintenance carried out on the particular item in question;
- Technological advances, which may make an asset obsolete or very difficult to maintain;
- Legislation, particularly in the area of Health and Safety.

Factors such as inflation must be borne in mind when calculating the total future replacement costs of plant, equipment and building fabric. Once a final estimate of replacement cost has been arrived at, this cost is then divided by its expected useful life to give an annual charge for each item to be apportioned among the tenants.

This calculation should be reviewed on an ongoing basis as technological advances, actual expenditure and cost inflation may materially effect the initial calculation and revisions may be necessary.

While at first reading both sinking funds and reserve provisions may seem like an additional onerous annual burden, the alternative of one-off large expenditure charges for fiscally-managed entities maybe more concerning.

In all cases it is worth bearing in mind when entering into leases the obligations attached to them; especially what you may be expected to fund, and how this will be administered.

While at first reading both sinking funds and reserve provisions may seem like an additional onerous annual burden, the alternative of one-off large expenditure charges for fiscally-managed entities maybe more concerning

when it arises, and that they can make better use of their funds in the meantime.

The other side to this is that should a property have no fund, a new tenant to the property will be required to pay their share of the cost of replacing or refurbishing equipment that they have never used. The new tenant could attempt to address this as part of their lease negotiations prior to signing.

It should be noted that the

these works, although whether the level of the fund is sufficient to meet the needs of the property requirements will have to be assessed.

The most usual method of establishing the level of fund required is to prepare an asset register of major plant, equipment and building fabric. The life expectancy and replacement cost of each item contained within the register is then estimated.

Don Collins Remembered

While I remember Don most for his generosity of spirit — be it in business matters or personal issues — my abiding memories inevitably turn to his sense of fun, his sense of mischief, and his penchant for playing pranks on people. Indeed, I'm convinced now that he's the first up there at the table looking down on us that, while undoubtedly keeping a space for us, he is planning some devilish trick to put one over on us on arrival. I was privileged to be part of Don's circle of close friends. We had the obvious more formally-arranged gatherings such as golfing trips around Ireland and abroad but, what we'll miss most is the almost casual way he telephoned a couple of times a month and arranged for the group members to meet for a quick sandwich, simply to keep in touch.

A thorough gentleman of the old school, Don was a friend to all, especially in times of need. While always there with a smile and a grin to celebrate the good times, his presence and support was even more obvious when things were not going so well for you.

That said, he loved stirring it and was always on the look out to put one over on you.

While his untimely departure is a severe blow, he will remain forever with us. I'm certain that he will be on the tee with us at our next outing and that, as I step up to hit off, he'll ruin my shot by shouting Hey Fatsoooo! Not that I would want it any other way.

Brendan Pluck



Having lost my mother in March and my father in July, both in their 80's, though hard to accept, I was happy in the knowledge that they had both lived long and fruitful lives, which contrasts greatly with the sudden passing of a very close and dear friend, Don Collins.

Growing up we make friends in childhood, school, college or through sport, but not very often through business. Though for me there have been exceptions, Don Collins being one of these, the other Jim O'Reilly, another great friend and associate of Don's, also taken from us before his time. We did not grow up together, but such was Don's personality it felt like we had known each other all our lives. Having worked with him for some 25 years perhaps we did grow up together without really knowing it.

I will always remember his sense of humour, to laugh when times were hard, that knowing smile when things were going well and the ability to keep things simple, play the game by the rules and everybody goes away happy, which always appealed to people like myself. To say we all miss Don is understating the obvious. His untimely death so close to my parents has left me feeling like I have lost another family member — which indeed I have.

Tony Callaghan

Don and I were work colleagues for the last 27 years, but he was more of a friend for a greater part of that time. Being practically the same age we shared so much of life's journey together. I will remember him for his loyalty and dedication to his work and to the people around him. His attention to detail and the planning and preparation he undertook are inspiring. He believed that if something was worth doing it should be done well.

I will remember him for his neatness, good taste and his love of things cultural. He enjoyed the natural beauty of the countryside and the ruggedness of Kerry and West Cork where he spent many happy times with his beloved Ann and David.

It was Don's personality and good humour and his natural ability to engage with people that endeared him to so many. I will remember him especially for his great humanity. He rejoiced with you in good news and fortune and when you were hurting he shared your pain. His great sensitivity enabled him to put things in perspective and assisted you in moving on. I will remember him and miss him dearly.

Oliver Fitzpatrick

THE 2-WAY

THE NEW MYSON TRV 2-WAY IS SET TO MAKE YOUR LIFE SO MUCH EASIER,
SINCE THERE'S NO NEED TO CHECK THE DIRECTION OF THE WATER FLOW.

THAT'S

COSTLY CALL-BACKS DUE TO "SNAGGING" WON'T BE PUTTING PRESSURE ON YOUR TIME
OR YOUR BUSINESS. BUT HERE'S WHY THE COMPETITION IS REALLY RATTLED.

GOT THE

ONLY THE NEW MYSON TRV 2-WAY'S UNIQUE ENGINEERING ALLOWS THE VALVE TO OPERATE CORRECTLY AT
ALL DIFFERENTIAL PRESSURES, IN EITHER FLOW DIRECTION, WITHOUT LOSS OF PERFORMANCE.

COMPETITION

SEND WATER THE WRONG WAY THROUGH AN ORDINARY TRV AND IT'LL RATTLE.
WHO NEEDS THAT KIND OF PRESSURE? FIT THE NEW MYSON TRV 2-WAY AND ENJOY A QUIETER LIFE.

RATTLED



MYSON
TRV 2WAY



Available in Polished Chrome, Satin Brass or Nickel finishes, in a full range of sizes. For more information contact Myson Heating Controls Ltd,
Newcastle West, Co Limerick. Tel: 069 - 62277; Fax: 069 - 62448; email: enquiries@myson.ie Website: www.myson.ie

TINYTAG TRANSIT



AUTOMATIC TEMPERATURE LOGGING AT AN INCREDIBLE LOW PRICE!

Designed to meet the stringent high standards of temperature monitoring in the food transportation field, this little stand-alone battery-operated temperature logger is the perfect solution in most applications which range between -30 to +50°C. Capable of recording approximately 1800 readings with a 1 sec. to 10-day interval, and combining the flexibility of a push button or delayed start, you'll be amazed at how little it costs.

The software and cable that are included will allow the recorded information to be downloaded and presented in numerical or graph format. Data can also be transferred to other windows applications for presentation with reports. Since additional loggers can be purchased at a reduced cost due to no further software being required, businesses needing multiple locations monitored will benefit even further from the TINYTAGTRANSIT's low cost.

- 1800 readings approx.
- Two programmable alarms
- 1 second to 10-day logging interval
- Timed and push-button start available
- Offload data when stopped or when at 1-min logging intervals
- Battery life up to two years
- Min/Max/Actual readings
- Memory size 2k (non volatile)
- Three stop options
- Software and cable included

For further information or a demonstration contact:

Manotherm Limited
 THE CONTROL CENTRE
 4 Walkinstown Road, Dublin 12.
 Tel: 01 - 452 2355; Fax: 01 - 451 6919
 email: manotherm@eircom.net

