

2016

GA Based Optimal Control for Maximizing PV Penetration at Transmission

Chittesh Veni Chandran

Dublin Institute of Technology, chitteshvc@gmail.comFollow this and additional works at: <https://arrow.tudublin.ie/sjer> Part of the Oil, Gas, and Energy Commons

Recommended Citation

Veni Chandran, Chittesh (2016) "GA Based Optimal Control for Maximizing PV Penetration at Transmission," *Student Journal of Energy Research*: Vol. 1: No. 1, Article 3.

doi:10.21427/D7WM9W

Available at: <https://arrow.tudublin.ie/sjer/vol1/iss1/3>

This Article is brought to you for free and open access by the Journals Published Through Arrow at ARROW@TU Dublin. It has been accepted for inclusion in Student Journal of Energy Research by an authorized administrator of ARROW@TU Dublin. For more information, please contact yvonne.desmond@tudublin.ie, arrow.admin@tudublin.ie, brian.widdis@tudublin.ie.



This work is licensed under a [Creative Commons Attribution-NonCommercial-Share Alike 3.0 License](https://creativecommons.org/licenses/by-nc-sa/3.0/)

GA BASED OPTIMAL CONTROL FOR MAXIMIZING PV PENETRATION AT TRANSMISSION

Chittesh VC*

*Postgraduate Researcher, Dublin Institute of Technology
Email: chitteshvc@gmail.com

Abstract

Utilization of distributed energy resources(DER's) like photo-voltaic generators, is one of the possible solution for present scenario of energy crisis. Most of the study suggest the implementation of PV power stations at distribution level. In this paper detailed theoretical analyses of the impact of large scale PV on transmission level is analysed. The preliminary section of this paper provides literature review with specifications of IEEE-14 bus network. Two methodology ie, constant load method and maximum loading method is implemented here. A test study is done in IEEE 14 bus to find out the optimal location of solar photo-voltaic generator (SPVG)and to find the maximum safe instantaneous penetration with both method using genetic algorithm (GA). Maximum penetration is achieved by adjusting grid parameters subjected to various power system stability and security constraints. Finally it can be concluded that GA based optimal control of large scale PV penetration allows us to utilize SPV power efficiently.

1. INTRODUCTION

Recently lot of researches are going on in the field of distributed energy resources(DER's). Governments of all nations are prompting implementation and utilization of DER's. This scenario arises to the well known fact that the increased demand cant be met by conventional energy resources only. So there has been a quest in finding new renewable resource and to make them more efficient. Of all DER's more concern is given to photovoltaic (PV) generators as it is easy to set up and can be distributed through out. Hence we can see that this has been the beginning of a solar revolution. But as the share of DER's(PV) increases various stability and security concern arises. As to this fact a through investigation and study is needed to find the impact of PV penetration on stability and security of power system even before considering the installation. Optimally placing and sizing of SPVG in power system would lead to attainment of numerous potential benefits and hence, an suitable algorithm is required to maximize these potential benefits without violating the stability or security constraints[13]. A large-scale PV generation system includes photovoltaic array, DC/AC converter and the associated controllers. On the basis of technology, applications, controlling techniques, the free running pollution free PV generators has been a worthy topic for power system researchers[5,7,4,8]. Various MPPT techniques used for producing maximum out put from solar PV generators(SPVG) has been discussed in [5]. Interfacing PV system to grid is being analysed in[10, 4]. In [11]

new control approach for hybrid feeding the power system with PV and conventional generators is discussed. Detailed mathematical and simulation modelling of PV are presented in[14, 15].Due to efforts from researchers the efficiency of PV has increased dramatically and the price has reduced to affordable limit.

Design and operation of system with high PV penetration will require improved understanding of PV behavior since its a multivariate non linear system and its performance depends on environmental conditions.Technical concerns with integrating higher penetrations of photovoltaic (PV) systems include grid stability, voltage regulation, power quality (voltage rise, sags, flicker, and frequency fluctuations), and protection and coordination. Now, the current power system was build for unidirectional power flow ie, from generating station to distribution, but increased PV penetration will challenge this classical paradigm.Most of the distribution system components like relay protection systems etc were not designed to operate with bidirectional power flow and would require resetting or replacement. And again, the reactive power support in the transmission system reduces as conventional generation is decommitted[2]. But still, by increasing PV penetration the line loss is reduced, voltage profile is improved, power quality is improved, the cost of power reduces, decreases peak power requirements, increases reliability, increases efficiency, and reduces environment impacts[1, 12, 9, 3]. Also increased PV penetration will reduce load on conventional generators and again the

low voltage ride through capability of PV would help to overlook the negative impact on system reliability.

Rest of the paper is organized as follows. Section 2 explains the basic modelling of SPV. In section 3 IEEE 14 bus test system and analysis tool box are explained. In 4 the Objective and constraints are formulated. 5 gives the methodology used. Results and conclusions are presented in the subsequent sections.

2. MODELLING OF SPVG

Equivalent circuit of solar PV module is given in the Fig 1 and the electrical circuit is described by the following equations

$$i_{dc} = i_L - i_D - V_D/R_{sh} \quad (1)$$

$$0 = v_D - v_{dc} - R_{se}i_{dc} \quad (2)$$

$$0 = i_s(\theta)(e^{v_D/(\gamma v_\theta(\theta))} - 1) - i_D \quad (3)$$

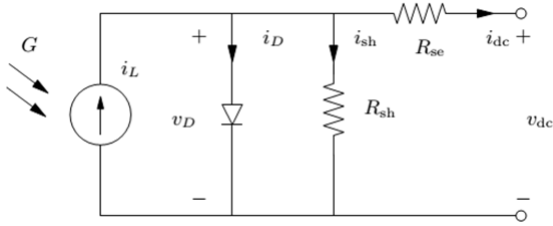

Fig. 1. Equivalent circuit of SPV

where i_L is the photo-current generated by solar panel, v_D and i_D are the PN junction voltage and current, respectively, v_θ is the thermal potential, i_s is the reverse saturation current. The variables v_θ and i_s can be expressed as:

$$v_\theta(\theta) = \frac{k_B \theta}{q_e} \quad (4)$$

$$i_s(\theta) = i_{s0} \left(\frac{\theta}{\theta_a} \right)^3 e^{\varphi(\theta)} \quad (5)$$

where θ is the cell temperature and the function $\varphi(\theta)$ is:

$$\varphi(\theta) = \frac{q_e}{\gamma K_B} \left(\frac{E_g(\theta_a)}{\theta_a} - \frac{E_g(\theta)}{\theta} \right) \quad (6)$$

and $K_B = 1.381 \times 10^{-23} J/K$ is the Boltzmanns constant, $q_e = 1.602 \times 10^{-19} C$ is the electron charge, and E_g is the energy band gap. The light-generated current can be linearized around a temperature of 298K and an irradiance(G) of $1000 W/m^2$:

$$0 = (A_a \rho_e G + C_\theta(\theta - 298)) \frac{G}{1000} - \frac{S_n}{V_{dc,n}} i_L \quad (7)$$

Finally, the model is completed by an energy-balance differential equation that regulates the cell heat transfer with

the ambient. There are different type of modelling approach for modelling solar PV module efficiently [14][15]. The modelling approach used here is relevant to the simulation software used (PSAT) and was developed by Fedrico milano in his book[7].

3. TEST SYSTEM AND TOOL

IEEE-14 bus test system, which is typically used for low frequency oscillation studies, has been used in this work.

1) *IEEE-14 Bus Test System* : Single line diagram of IEEE-14 bus test system is depicted in Fig 2. The bus system consists of 5 generators, of which one is slack and there are 20 lines. Bus 2, 3, 6 and 8 are PV buses and 3, 6 and 8 are synchronous compensator buses. It has generators located at buses 1, 2, 3, 6, and 8 and four transformers with off-nominal tap ratio in lines 4-7, 4-9, 5-6 and 8-9. The lower voltage magnitude limits at all buses are 0.9 p.u. and the upper limits are 1.1 p.u. Total real and reactive power of load is 259 MW and 81.4 MVar respectively. Total generation includes real power generation of 272.6 MW and 108.83 MVar of reactive power. Load bus voltages are maintained to be between 0.9 and 1.1 p.u. Total active power loss is 13.597 MW. PV generator is connected to the system to study the impact of increasing loading level, position and penetration level.

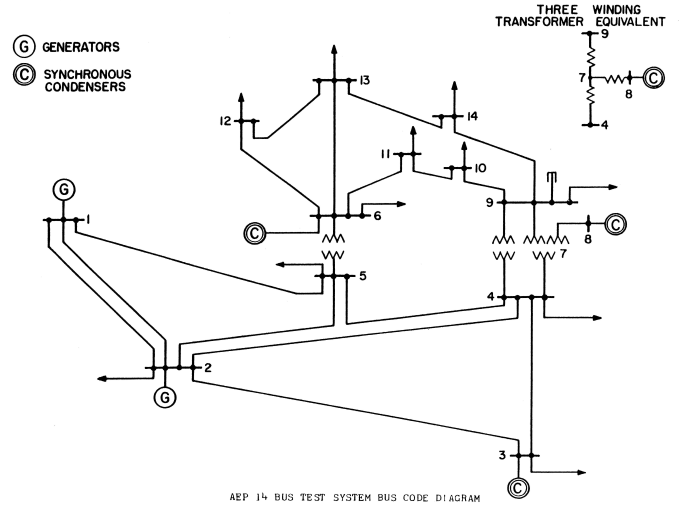

Fig. 2. A schematic diagram of grid connected PV system

A. Tool

Results presented in the paper were produced by MATLAB (R2010a)-based software PSAT [6]. PSAT 2.1.8 version was used to develop the PV based generator function file.

4. PROBLEM FORMULATION

Penetration of PV power in the proposed system has to be increased to the maximum to find the optimal location, and meanwhile, should not violate the stability of the system. Maximum value of PV power depends on various stability constraints associated to the grid and other power system components. By increasing the PV power we are reducing the use of conventional generators and in effect we are able to reduce the generation cost. Further, by reducing the conventional generation we are able to reduce the carbon production and reduce the environmental impact of energy plant.

A. Objective function

For a generalized model, increasing PV penetration means to increase the power output of all distributed PV generators connected to the system. Here system with single PV generators is considered. So maximization of output of single generators done which is the objective function. Accordingly the objective function will be

$$\text{Maximize } F(x) = \sum_{i=1}^n x_i \quad (8)$$

where $F(x)$ is the total capacity of grid-connected PV power stations; x_i is the capacity of each PV power station, which is decision variable; n is the number of PV power stations. The output of the PV depends on the irradiation and the ambient temperature, but, in this study we are considering that solar PV is able to of infinite capacity as we are keen to find the maximum possible penetration.

B. Generators and system operation constraints

The constraints are the operating boundaries of the system and they define the stable operating condition. The constraints of proposed problem include voltage limits, real and reactive power balance, stability limits. The constraints are basically two types :

Equality constraints:

$$P_{Gi} = P_{Li} + V_i \sum_{j=1}^{N_b} V_j (G_{ij} \cos \delta_{ij} + B_{ij} \sin \delta_{ij}) \quad (9)$$

$$Q_{Gi} = Q_{Li} + V_i \sum_{j=1}^{N_b} V_j (G_{ij} \sin \delta_{ij} - B_{ij} \cos \delta_{ij}) \quad (10)$$

$i = 1, 2, \dots, N_b$

where i and j are numbers of power grid buses; P_{gi} and Q_{gi} are active power and reactive power of conventional units; P_{Li} and Q_{Li} are active and reactive load; P_{pi} and Q_{pi} are active power and reactive power of PV power stations; V_i , V_j and δ_{ij} are voltage magnitudes and phase angle; G_{ij} and B_{ij} are elements of admittance matrix. And, N_b is the number of buses in the system.

Inequality constraints: They are the limits of maximum and minimum allowable operating values for stable operation of power systems. They include Generator active power P_{Gi} , reactive power Q_{Gi} , voltage V_i , and phase angle δ_i which are restricted by their limits as follows:

$$P_{Gi}^{min} \leq P_{Gi} \leq P_{Gi}^{max} \quad i = 1, \dots, m \quad (11)$$

$$Q_{Gi}^{min} \leq Q_{Gi} \leq Q_{Gi}^{max} \quad i = 1, \dots, m \quad (12)$$

$$V_{i min} \leq V_i \leq V_{i max} \quad i = 1, \dots, N_b \quad (13)$$

$$-0.9 \leq \delta_i \leq 0.9 \quad i = 1, \dots, N_b \quad (14)$$

m is the number of generator buses The constraint of transmission loading P_{ij} is represented as

$$|P_{ij}| \leq P_{ij}^{max} \quad ij = 1, \dots, N_l \quad (15)$$

The load factor λ_f is constrained by its limits as:

$$1 \leq \lambda_f \leq \lambda_f^{max} \quad (16)$$

Other than these security constraints, various stability limits were also accounted by evaluating defined indices using the robust controllers.

1) *Fast Voltage Stability Index:* Fast Voltage Stability Index (FVSI) proposed by Musirin [8] is utilized in this paper to assure the safe bus loading.

$$FVSI_{ij} = \frac{4Z^2 Q_j}{V_i^2 X} \quad (17)$$

The line that exhibits FVSI close to 1.00 implies that it is approaching its instability point. If FVSI goes beyond 1.00, one of the buses connected to the line will experience a sudden voltage drop leading to the collapse of the system. FVSI index incorporation in the controller assures that no bus will collapse due to overloading.

2) *Line Stability Factor:* System Stability Index is also assured by Line Stability Factor (LQP) proposed by A Mohamed et al [8]. The LQP should be less than 1.00 to maintain a stable system.

$$LQP = 4 \left(\frac{X}{V_i^2} \right) \left(\frac{X}{V_i^2} P_i^2 + Q_j \right) \quad (18)$$

LQP assure the controller that no line is over loaded under any grid condition.

5. METHODOLOGY

Initially, Newton-Raphson based conventional power flow is conducted on IEEE 14 bus system at fundamental frequency to calculate the voltage, real and reactive power flow which forms the base case without controller.

A. Constant load Method

In constant load method(Generation Displacement method) loads are kept constant but the SPV generations are controlled using controller. In IEEE 14 bus the slack generators are not controlled and participate in supplying the load. GA finds the optimal location in both IEEE 14 bus system for maximum penetration taking into account the power balance constraints and stability constraints.

B. Maximum load Method

Here the load is increased to the maximum using GA and the SPV generator output is also controlled. The SPVG will contribute maximum to the increased load without violating any security or stability limits. This is achieved on both system using the controller. Optimal location is found by placing SPVG at random bus location and then increasing the generation till there is a violation of any stability or security limits. The controller finds a location for SPVG which will be the optimal location for maximizing the penetration. To find the maximum penetration for a system the load is increased to a maximum value by utilizing a load factor and then the maximum load is shared by the SPV system. Here the load is varied according to the equation

$$P_{Li}(\lambda) = \lambda P_{Li} \quad (19)$$

$$Q_{Li}(\lambda) = \lambda Q_{Li} \quad (20)$$

where, $i = m + 1, \dots, N_b$

and m is the total number of generator buses. λ is the load increase factor which will be used to increase the load in step by step manner and when it is 1 indicates the base load case.

6. GENETIC ALGORITHM

Genetic algorithm (GA) is a soft computing based search technique used to find out the optimum value of an optimization problem. The GA technique is invented by John Holland from the inspiration of biological population. Since the GA can handle both discrete and continuous objective function and constraints, it can be used to solve complex design optimization. A typical GA requires a solution domain and a fitness function. The different entities of genetic algorithm are encoding, evolution, constraints, and different operators like crossover and mutation. The detailed explanation of genetic algorithm is not included in this paper due to space constraints [12,13] and is as well out of its scope. The workflow of a genetic algorithm is shown in the flowchart given below.

7. RESULTS AND DISCUSSIONS

Initially, the solar PV is connected to a separate bus which is the 15th bus. The 15th bus is considered and modelled as a $V\theta$ bus and maximum amount of load is supplied by the solar PVG resulting in minimum participation by

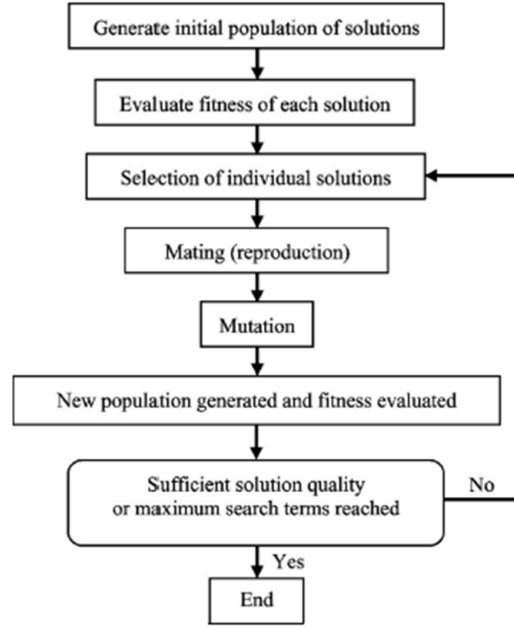

Fig. 3. Basic GA flowchart

conventional generators. This arrangement is considered as the SPV bus for reference. This SPV bus is randomly connected to different feasible locations in the network and power flow is conducted. The algorithm will vary the power injection and load in the system and different locations of SPVG gives different power flow results. Maximum instantaneous penetration will depend on various factors which are considered as the constraints or limitations by the algorithm, for eg: location, load centers, line loading capacity, reactive power demand etc. The load on the buses is kept constant for constant load method and generation by SPVG is increased to the maximum by controlling the voltage and angle of SPV bus. But the load generation balance is maintained always by adjusting the output from the SPVG and conventional generation. Also by placing the SPVG nearer to the intermittent generator like wind turbine generators, it can be made to absorb most of the oscillations caused due to the fluctuating output from the wind generator as SPVG is less volatile considering the instantaneous power production compared to wind. In this work the control variables considered are the slack bus voltage and angle settings to control the load sharing between the SPVG and the conventional generators which are at buses 1 & 2. Using Genetic Algorithm, the optimal location of SPVG for maximum penetration at transmission level was found to be at bus 4. This was the optimal location even if the distribution side was also considered. Bus no 1,2 and 3 were not considered as feasible location since, they have generators already connected to them and the load center in

IEEE 14 bus system is near to the 4th bus(almost 50%). The base case load was 2.66pu, ie 266 MW and this load was kept constant in 1st method. Initially without SPVG total load was supplied by the generators 1 & 2. when SPVG was connected at 4th bus the 2.02pu of the total generation ie, about 73.18% is shared by it. With GA this increased to 2.32pu that is about 84.05% of the total generation was done by SPVG at its optimal location.

Now with maximum load method the load is increased to the maximum possible value and the contribution of SPVG in supplying this is found out. The loading of the IEEE 14 bus test system without integration of SPVG can only be increased to 1.2 times the base case loading beyond which the system drives into instability and collapses. With the optimal placement and setting of SPVG the loadability can be increased from the base case loading of 260 MW to 627MW. This is done using GA. The load is randomly varied and with that the SPVG voltage and angle is controlled to get maximum possible penetration. The optimal location was found to be at 4th bus and SPVG was producing 556MW which is 83.10% of total generation which is equal to 669MW. The maximum system loading was 241% by considering stability constraints. Total generation and load at maximum system loading is given in Table. I. From the

TABLE I
GENERATION AND LOAD OF IEEE 14 BUS

	P_G (p.u)	Q_G (p.u)	P_L (p.u)	Q_L (p.u)
BASE CASE	2.85	1.308	2.664	0.856
CONSTANT LOAD	2.764	1.033	2.664	0.856
MAXIMUM LOAD	6.687	3.074	6.273	1.611

table it is evident that with optimal placement & setting of SPVG, maximum penetration can be obtained. From fig 4 and fig 5 it can be observed that with base case load, constant load and maximum load the voltages at all buses are within the specified limits ie, 1.1 to 0.9.

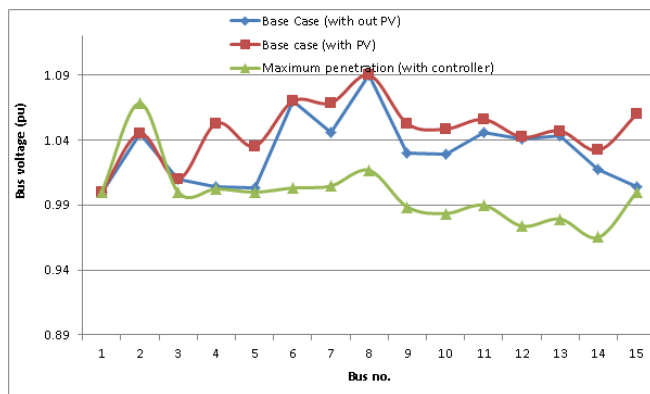

Fig. 4. Voltage levels with and without SPVG(Constant Load)

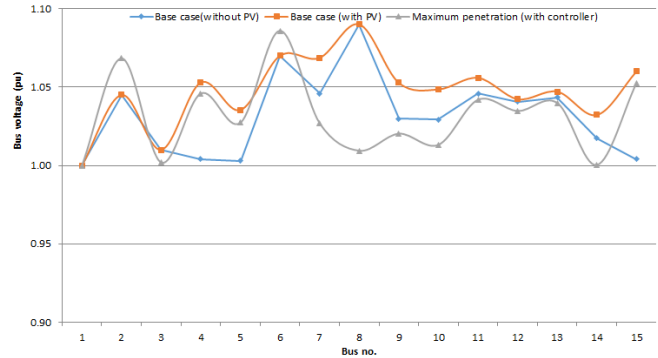

Fig. 5. Voltage levels with and without SPVG(Maximum Load)

Fig. 6 and 7 shows the Generations at different buses. It can be seen that with optimal placement and setting of SPVG at bus 4, the conventional generations can be reduced and the whole load disturbance is absorbed by the SPVG. Bus 3 has the largest load share and GA is able to accurately locate the best suitable location for placement of SPV bus at bus 4 which is near to the load center. Also with optimal placement and setting of SPVG at bus 4, the load on the conventional generator at bus 1 (Mpthr Slack) has considerably reduced and most of the load increase is shared by the SPVG in maximum load method.

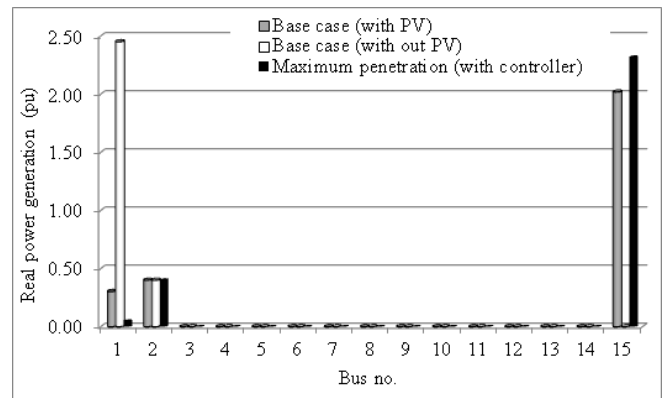

Fig. 6. Generations with and without SPVG(Constant Load)

Loads at different buses are given in fig 8. In maximum load method the load has increased upto 240%.

In fig. 9 & fig 10 line power flows with and without SPVG is shown. For constant Load the line flows are different from base case as generation has been displaced. The line active power flows increases as the system loading is increased but the stability constraints assures that the increase is within the stability and security margins of the power system.

From the figures 4 to 10 it is proved that the GA algorithm together with the stability constraints is better

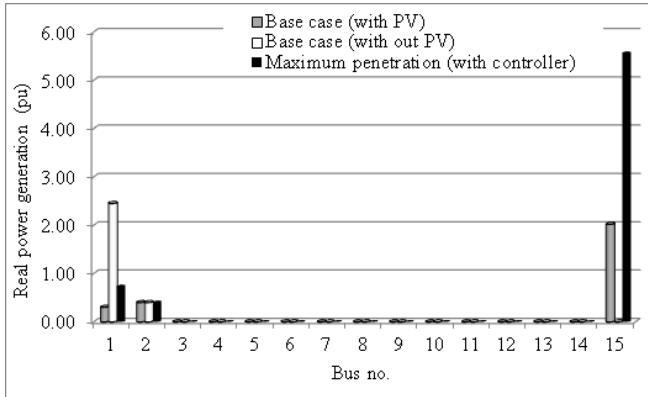

Fig. 7. Generations with and without SPVG (Maximum Load)

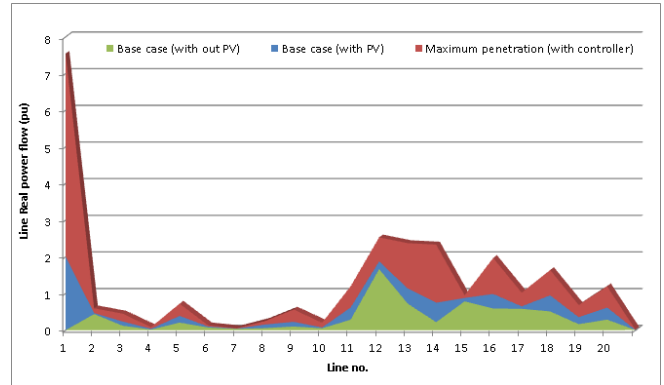

Fig. 10. Line flow with and without SPVG(Maximum Load)

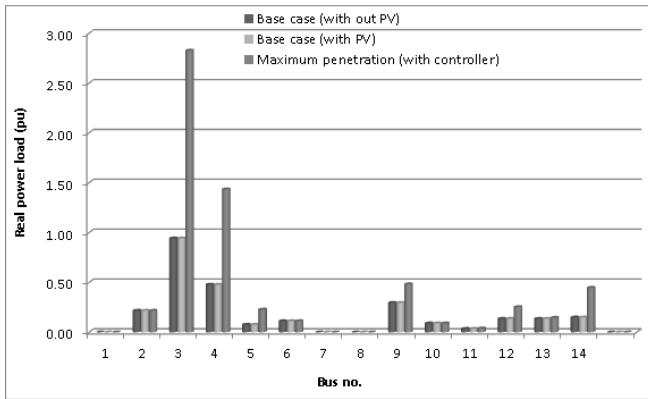

Fig. 8. Loads with and without SPVG(Maximum Load)

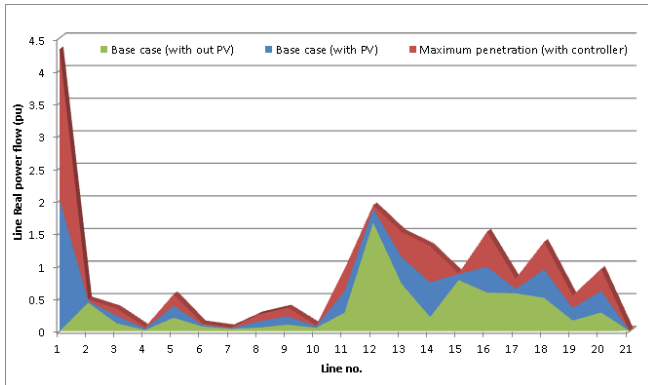

Fig. 9. Line flows with and without SPVG(Constant Load)

able to optimally place the SPVG at transmission level to maximize penetration assuring grid stability at all levels of system loading.

8. CONCLUSION

A clinical system level analysis is presented in this paper which is useful for design and installation of solar

PV generator. In the current scenario, where utilities are encouraging the installation of renewable solar PV, the result from this analysis will help to decide the maximum possible penetration with stable system operation. The paper utilizes two methodologies (generation displacement method and maximum load method) to find the best location as well as to decide the maximum possible rating of proposed PVG. Genetic algorithm based stochastic optimization method is used as the tool to find optimal location and maximum rating using two methods and to implement the proposed algorithm to find the same. Table II gives maximum penetration of solar power in IEEE 14 bus standard test system with two methods. Incorporation of Fast voltage stability index (FVSI) and Line stability factor (LQP) constraints in the optimization problem ensures grid stability at various levels of system loading. If optimal placement of SPVG near to load center is considered, then major part of the load disturbance can be accommodated by the SPVG by implementing an intelligent control. The applicability of the proposed scheme was tested on a standard IEEE 14-bus system at constant load and maximum load using Newton Raphson power flow method. This method of analysis can be utilized before installing any form of generation system and based on this result economic calculation can be carried out.

TABLE II
MAXIMUM PENETRATION IN IEEE 14 BUS

METHOD	PENETRATION (WITHOUT CONTROLLERS) %	PENETRATION (WITH CONTROLLERS) %
CONSTANT LOAD	73.18	84.05
MAXIMUM LOAD	73.26	83.10

REFERENCES

- [1] The Potential Benefits of Distributed Generation and the Rate- Related Issues That May Impede Its Expansion. 2005.
- [2] S Achilles, S Schramm, and J Bebic. Transmission System Performance Analysis for High-Penetration Photovoltaics Transmission System Performance Analysis for High-Penetration Photovoltaics. (February), 2008.
- [3] Thomas Ackermann, Göran Andersson, and Lennart Söder. Distributed generation: a definition. *Electric Power Systems Research*, 57(3):195–204, April 2001.
- [4] Aggelos S Bouhouras, Antonios G Marinopoulos, Dimitris P Labridis, and Petros S Dokopoulos. Installation of PV systems in GreeceReliability improvement in the transmission and distribution system. *Electric Power Systems Research*, 80(5):547–555, May 2010.
- [5] Trishan Eram and Patrick L Chapman. Comparison of Photovoltaic Array Maximum Power Point Tracking Techniques. 22(2):439–449, 2007.
- [6] Federico Milano. psat-manual. 2008.
- [7] Federico Milano. *Power system modelling and scripting*. Springer Science & Business Media, 2010.
- [8] I Musirin and TKA Rahman. Novel fast voltage stability index (FVSI) for voltage stability analysis in power transmission system. *Research and Development*, 2002, pages 265–268, 2002.
- [9] Belmans R Pepermans G , Driesen J , Haeseldonckx D , D haeseleer W . DISTRIBUTED GENERATION : DEFINITION , BENEFITS AND ISSUES. 32(0):0–21, 2003.
- [10] Dash PP. Design methodology and stability analysis for a photovoltaic (PV) plant interfaced with a distribution network. 2008.
- [11] Mohamed Rashed, a Elmitwally, and Sahar Kaddah. New control approach for a PV-diesel autonomous power system. *Electric Power Systems Research*, 78(6):949–956, June 2008.
- [12] A A Bayod Rújula, J Mur Amada, J M Yusta Loyo, and Domínguez Navarro. Definitions for Distributed Generation : a revision Keywords :.
- [13] R Shah, N Mithulanathan, a Sode-Yome, and K Y Lee. Impact of large-scale PV penetration on power system oscillatory stability. *IEEE PES General Meeting*, pages 1–7, July 2010.
- [14] Yun Tiam Tan, Student Member, Daniel S Kirschen, Senior Member, and Nicholas Jenkins. A Model of PV Generation Suitable for Stability Analysis. 19(4):748–755, 2010.
- [15] W Xiao and FF Edwin. Efficient approaches for modeling and simulating photovoltaic power systems. *Photovoltaics, IEEE*, 3(1):500–508, 2013.