

11-1-1964

The Irish Plumbing and Heating Engineer, November 1964 (complete issue)

Follow this and additional works at: <https://arrow.tudublin.ie/bsn>



Part of the [Civil Engineering Commons](#), [Construction Engineering Commons](#), and the [Construction Engineering and Management Commons](#)

Recommended Citation

(1964) "The Irish Plumbing and Heating Engineer, November 1964 (complete issue)," *Building Services News*: Vol. 4: Iss. 8, Article 1.

doi:10.21427/D7SX3S

Available at: <https://arrow.tudublin.ie/bsn/vol4/iss8/1>

This Article is brought to you for free and open access by the Journals at ARROW@TU Dublin. It has been accepted for inclusion in Building Services News by an authorized administrator of ARROW@TU Dublin. For more information, please contact yvonne.desmond@tudublin.ie, arrow.admin@tudublin.ie, brian.widdis@tudublin.ie.



This work is licensed under a [Creative Commons Attribution-Noncommercial-Share Alike 3.0 License](#)



ENGINEER



BOSS RAD 66. and 100.

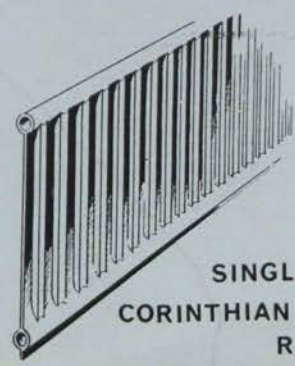

SINGLE & DOUBLE
CORINTHIAN COPPER
RADIATORS

**THE
BRITISH STEAM
SPECIALTIES
LTD.**

supply heating and pipeline
equipment for factories, stores,
offices and public buildings
B.S.S. Ltd. can supply complete
equipment for heating installations
and all ancillary equipment for steam,
water, gas, oil and compressed air
pipelines.
B.S.S. Ltd. have large stocks available
from branches at Dublin and Belfast.

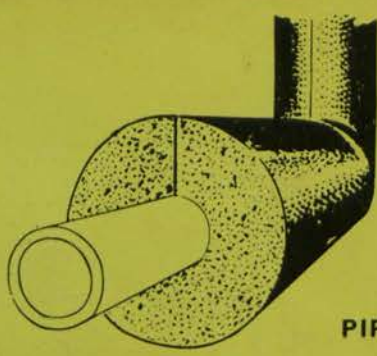

FOAM FLEX
1/4" - 4" PIPES
PREFORMED
PIPE INSULATION



DUBLIN

33 Leeson Park
Dublin, 6
Dublin 66961-2-3-4
Telex 317

BELFAST

Distillery Street
Belfast, 12
Belfast 28031 (3 lines)
Telex 74561



BOSS WHITE

BOSS TANK
Contents GAUGES



CLAUDO
VALVES



for Water,
Oil and Air.

GLENFIELD & KENNEDY S.&S.
DIAPHRAM
VALVES



for use on
Water, Oil,
Air and Gas

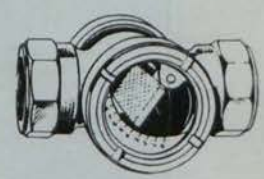

RHODES
Sight Flow
INDICATORS



perfection
in
plastic

The cistern which is *different* — not only in its elegant form and brilliant finish, but also in hidden values; in its built-in strength and mechanical excellence.

ETERNA by **Fordham**

FORDHAM PRESSINGS LTD., DUDLEY RD., WOLVERHAMPTON. Tel: WOLVERHAMPTON 23861/2
Other Factories at Earlsfield (London), Hinckley (Leics.), Sedgley (Staffs.)

EASY COMPACT INSTALLATION FOR WATER SUPPLY



Self-priming with a suction lift of 25 feet, the electric driven M range of Mono Pumps are compactly constructed, flange mounted to a motor of very low power consumption. Its silent operation permits installation in any convenient position and the non-pulsating, steady flow will not transmit noise through the pipeline. No oiling or greasing of the pumping element is required and no foot valve necessary.

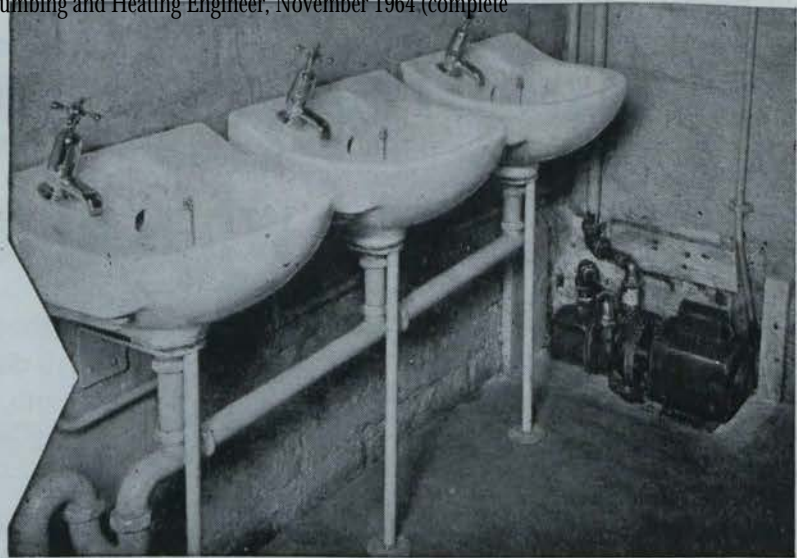

The **MONO** pump

Attractive terms to Dealers

MONO PUMPS LIMITED, 31b CENTRAL HOTEL CHAMBERS, 7/9 DAME COURT, DUBLIN.
Telephone Number: Dublin 70843. MP251

A Newcomer To The Irish Market

RENNERT & CO., Gmbh., Dusseldorf

Manufacturers of Sanitary Fittings since 1919

● MAKERS OF QUALITY
FITTINGS FOR BATHS,
BASINS, SINKS, ETC.

● **temperfix**
THERMOSTATIC VALVES

Agent for Ireland:



G. F. MORLEY Ltd.
45 Quinn's Lane,
Fitzwilliam Square,
Dublin 2. Tel. 66949.

Cocks & Mixers

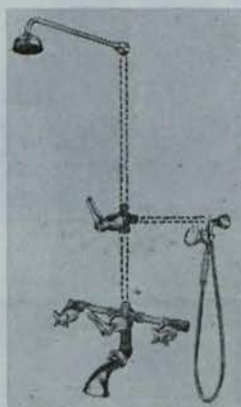

ABOVE — No. 615 NMG.IV. Combined Bath Mixer with overhead shower and shampoo attachment. (Concealed piping).



ABOVE—Pillar Cock.
BELOW — Highneck sink pillar cock with raised nose giving 4" clearance.

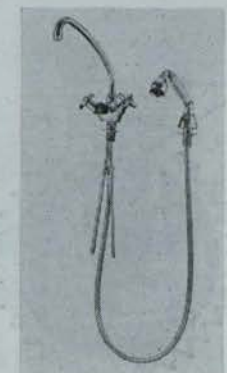

ABOVE — No. 325 NMG. Combined Sink Mixer with spray attachment. Suits normal sink tapholes.

Specify **FISHOLOW** and get exactly what you want

The range of FISHOLOW Stainless Steel Sinks is wide and the prices are low. The table below gives evidence for these statements. Their distinctive multi-fluted draining boards give efficient draining, great strength, good sound-deadening qualities and are easily cleaned. Top quality British stainless steel is the basis of their good looks and lifetime durability. A range of Vitreous Enamel sinks is also available. Please ask for fully descriptive literature. Barbour Index No.227

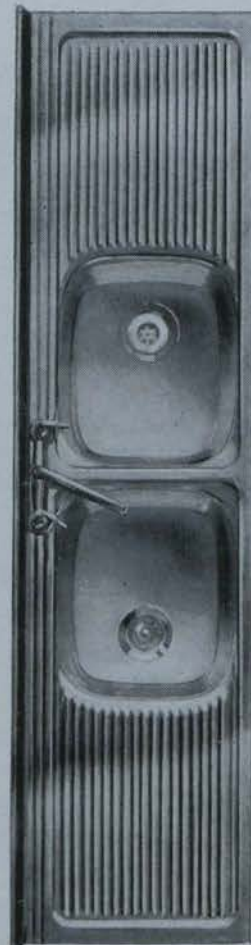
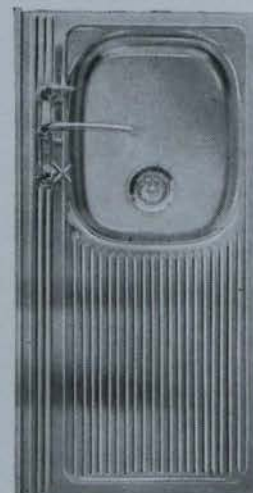

**for
EFFICIENT
DRAINING**

**for
GREAT
STRENGTH**











**for
BETTER
SOUND
DEADENING**

**EASILY
CLEANED
HYGIENIC**

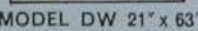

For Life

FISHER & LUDLOW LIMITED
(Dept. TSV) · BIRMINGHAM 24

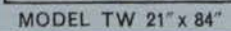
<p>MODEL L 18" x 36"</p> 	<p>MODEL DL 18" x 54"</p> 	<p>MODEL N 18" x 42"</p>  <p>MODEL W 21" x 42"</p> 	<p>MODEL WN 18" x 63"</p>  <p>MODEL WW 21" x 63"</p> 
<p>MODEL WL 18" x 54"</p> 	<p>MODEL TL 18" x 72"</p> 	<p>MODEL DN 18" x 63"</p>  <p>MODEL DW 21" x 63"</p> 	<p>MODEL TN 18" x 84"</p>  <p>MODEL TW 21" x 84"</p> 

ENGINEERING

THE ASBESTOS WAY

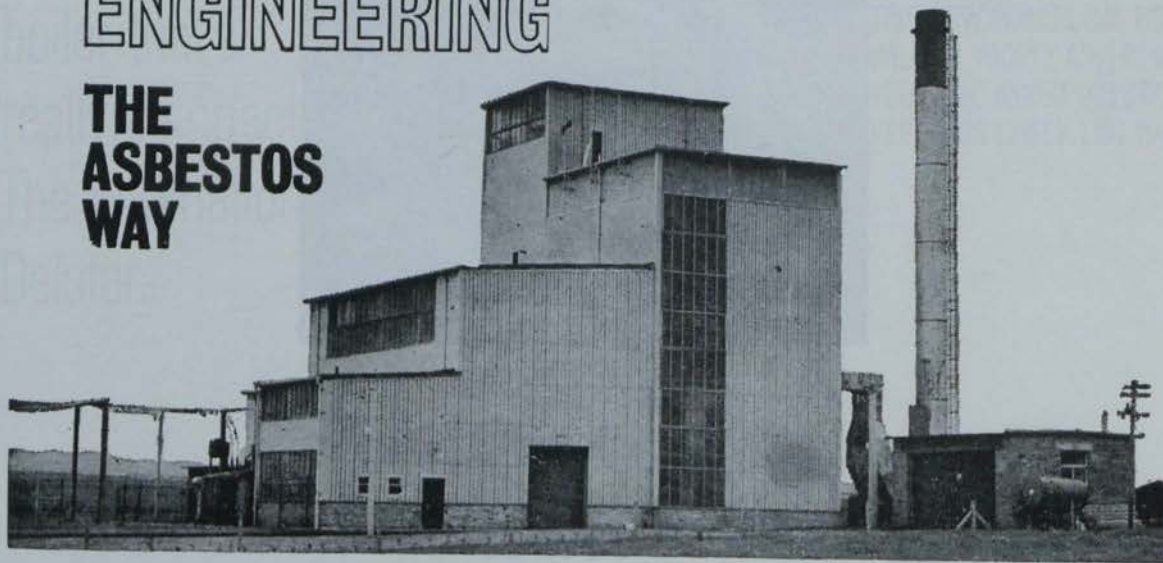

Asbestos Cement building materials are ideally suited for all engineering work.

These materials will not corrode, rust, or rot and are fire resisting.

Once fixed in position, being maintenance-free, they require no further attention.

For these reasons and because they are economical, engineers specify asbestos cement building materials, and furthermore they are approved by the Department of Local Government for grant purposes.



Asbestos

*OUR TECHNICAL ADVISORY DEPARTMENT
WILL GLADLY ADVISE YOU ON ANY
BUILDING PROBLEM.*

ASBESTOS CEMENT LIMITED, 19 LOWER PEMBROKE STREET, DUBLIN 2.

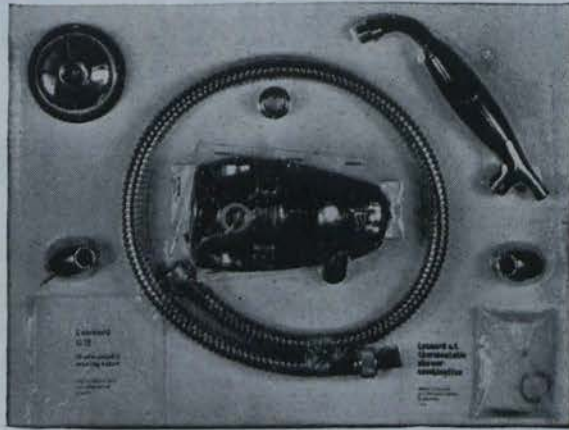

choose a packaged Leonard shower



Leonard-bif
The Leonard 72B built-in thermostatic mixing valve with flexible tube fitting.



Leonard-ef
The Leonard 72 with flexible tube fitting.

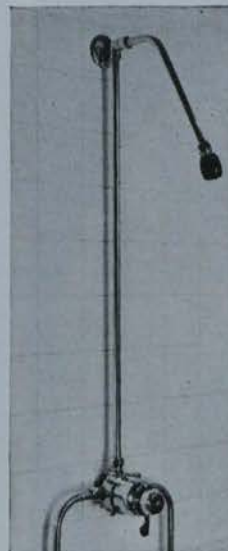

Leonard-er
Leonard 72 with two-position rigid fitting and low-head shower rose.



Leonard-bir
The Leonard 72B built-in thermostatic mixing valve with shower arm for use with concealed piping.

Leonard thermostatic showers are easy to choose, easy to buy, easy to install. Each shower combination is complete down to the fixing screws,

and cunningly packed for safe, whole and convenient delivery. The Leonard shower you choose is thermostatic. It includes a separate choice of the force of

the shower; it works off water pressures as low as 3' head. Leonard showers give you a choice from four standard combinations.

the sole distributors in Eire
Modern Plant Limited
Crumlin Road Dublin
Tel 54251/2/3
or any builders and plumbers merchant

At last! An oil boiler that's really compact. The International Delstar.

Delstar's design beats the rest on size, looks—and the programmer is standard equipment.

Clip this ad.

THIS NEW WALLFLAME BOILER WILL BE WIDELY ADVERTISED YOU'LL BE ASKED QUESTIONS SO KEEP THIS CHECK LIST HANDY.

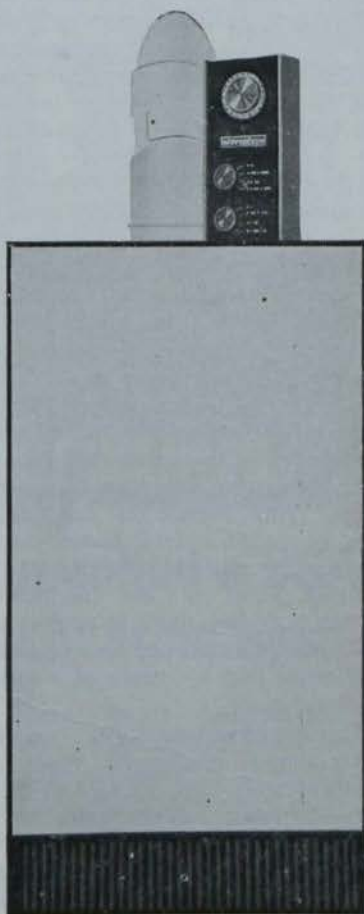
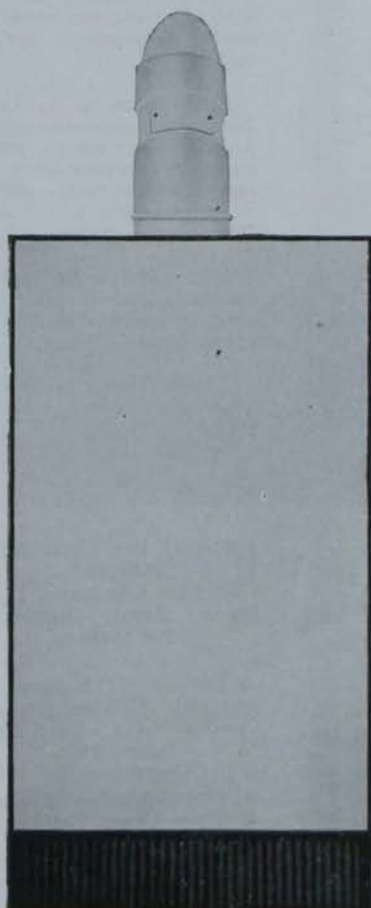

- 1 It measures only 36" high, 20" wide, 21" deep. It is smaller than any comparable wallflame boiler on the market.
- 2 The 10 position programmer is standard equipment. It controls independently the timed operation of the central heating and hot water systems. The programmer is designed for wall mounting and can be situated in any part of the house.
- 3 There are two models, 50,000 and 70,000 B.t.u./h.
- 4 Efficiency exceeds 80%.
- 5 Its quiet operation makes it suitable for installation in kitchens.
- 6 Maintenance is extremely simple—it was designed for easy servicing.
- 7 International Heatmiser for maximum fuel economy is available as an optional extra.

SEND FOR FULL DETAILS

International

BOILERS AND RADIATORS LTD

Park House, Park St., Croydon, Surrey. Tel: MUN. 3581/5

trade Topics

STEWARTS & Lloyds of Ireland Ltd., East Wall Road, Dublin, have added

S. & L. ADD TO THEIR PLASTICS RANGE

to their range of plastic products for the plumbing and water industry.

The range of the coiled High Density Polyethylene pipe has been increased to 3" and 4" nominal bores in continuous lengths wound on steel drums.

This is an ideal pipe for those special applications where corrosion is a problem—the pipe can be unreeled rapidly and very few joints are required. Recently 2,000 ft. of 3" n.b. pipe was laid in a prepared trench in 20 minutes. 5" and 6" pipes in straight lengths are also available.



Good example

ONE of the washrooms at the new factory recently opened by Lesney Products & Co. Ltd.—makers of the famous Matchbox toy series—is one of the most advanced buildings of its kind in design, layout and staff amenities.

The warm spray taps are foot-controlled and the temperature of the water is blended and thermostatically maintained at a preset level by the Leonard mixing valve, which can be seen mounted on the end wall.

Altogether, twenty-eight Leonard valves of various sizes (made by Walker Crossweller & Co. Ltd., of Cheltenham) are installed in the washrooms at this factory. Irish agents are Modern Plant Ltd.

The Company now markets P.V.C. pipe in sizes up to and including 6" n.b. The S. and L.P.V.C. pipe system from 2" upwards is based on the Ehri Socket Joint. Jointing and laying is extremely fast and the heavy rubber joint ring ensures leak tightness in all conditions. A full range of special is available.

* * *

RHEEM Glow-Worm Limited have introduced a new range of larger pressure jet oil fired central heating boilers

NEW, LARGER PRESSURE JET BOILER RANGE

—to be known as the "C" Series. Ratings, over five models, rise to 256,000 B.t.u./hr.

Waterways are of sectional cast iron construction and standard controls consist of a Nu-Way ZL2 burner, Danfoss 57F control box and Danfoss KT 59B thermostat.

All models, including the biggest, are surprisingly compact and all are enclosed in a pressed steel, fibre-glass insulated cabinet. Agents in Ireland: Monsell Mitchell & Co. Ltd.

* * *

THERMOSTATIC temperature controllers for small bore central heating systems enabling the radiator supply to be kept at a lower temperature than the domestic supply when both are off the same system, are manufactured by Meynell & Sons Ltd., Montrose St., Wolverhampton, and have been re-designed so that a thermometer is now included in the basic retail price.

REDESIGN OF MEYNELL'S MIXING VALVE

Meynelmix thermostatic hot and cold water mixing valves for showers, etc., with automatic safety device. A feature which is claimed to be unique in the design of the valves has recently been introduced to the Meynelmix range. This feature is designed to give an added safety factor to the thermostatic system whereby, in the unlikely event of the thermostatic system breaking, there is now an immediate and automatic opening of the cold water port by means of a spring-loaded piston.

This piston safety device is a relatively simple mechanism which the manufacturers have decided to incorporate without adding extra to the selling price. It is claimed that the feature incorporated into Meynelmix introduces a new era of special safety for schools, hospitals, hotels, etc., by means of thermostatic and automatic safety control.

IRISH PLUMBING & HEATING

ENGINEER

Vol. 4 No. 8. NOVEMBER, 1964
THE IRISH PLUMBING AND HEATING ENGINEER is the only publication produced in Ireland catering exclusively for the heating, plumbing and ventilation industries with a guaranteed circulation covering the Republic of Ireland and Northern Ireland every month.

W. J. R. Couchman has another part of his Seven Deadly Sins series for domestic heating installers. In this seventh part of the series he continues his discussion on heat requirements.

This month our Special Review feature deals with domestic hot water supply equipment and boilers.

In addition to A. L. Townsend's introductory article we carry an equipment review of recent introductions and developments in the fields under review.

Allen McDowell, our Northern correspondent, contributes another Northern Notes column.

Trade Topics review the month's news.

Editorial and advertising offices:
Callaghan Chambers, 13/15
Dame Street, Dublin 2.
Tel. 56465-6.

London: J. T. Robson & Son Ltd., 30 Fleet Street, London, E.C.4. Tel.: Fleet Street 4438.

Belfast: Allen McDowell, 43 Horn Drive, Belfast 11. Phone 614606.



NOT WANTED

-after you've installed a BSA Harford central heating system

You will not believe us if we tell you that you will **never** be called out to repair a B.S.A. Harford central heating system. (A really idiot-proof one has yet to be invented, but we're working on it).

We do claim—with experience to back us—that B.S.A. Harford systems need less attention than any others you can install. This

is partly because they're designed and made to B.S.A. standards, and partly because we satisfy ourselves that every single item is working before it leaves the factory. We don't do sample checks. Every single boiler, every pump, every valve and radiator, gets an *in-use* test, as exacting as we can make it.



IF YOU'D LIKE TO KNOW MORE, TURN ON 

The Irish Plumbing and Heating Engineer.

THE British Government's imposition of the 15 per cent. levy on imports is falling heavily on the manufacturers of space heating equipment. Last year exports of these items to Britain were worth £1.7 millions.

However, so far managements have been able to carry on without laying off staffs or seriously cutting production.

The recent Dail statements by the Taoiseach, Mr. Lemass, and the pass-

ing of the token estimates for aid where-necessary to industry hit by the levy and for a new "Buy Irish" campaign have been of some encouragement to manufacturers.

* * *

HEATOVENT Supply Co., who have moved to extensive new offices and stores at 379 St.

THREE NEW AGENCIES FOR HEATOVENT

appointment as agents in the Republic for Thermalrad convector radiators,

Circular Road, Rialto, Dublin, have now announced their ap-

trade Topics

Ranco valves, Sunstrip radiant heating and Solacoust heated acoustic ceiling.

Richard Crittal & Co. Ltd., manufacture Sunstrip overhead radiant panel heating system which features flexibility of design, simplicity in construction and maximum heating effect with high efficiency.

Solacoust heated ceilings provide heat by low temperature radiation. This system possesses low heat storage and thus satisfactorily responds to thermostatic control and changes in temperature of the heating medium. Both these products will be dealt with in detail in our December issue special feature on radiators and convectors.

Also accommodated at 379 S.C.R. are John R. Taylor Limited, agents in Ireland for Thomas Potterton Ltd., and Nu-Way Heating Plants Ltd., and O.B.C. Ltd.

Star *Stream*

2496 Deck Pattern Pillar Cock

Sperryn

Bath, Sink & Basin Fittings

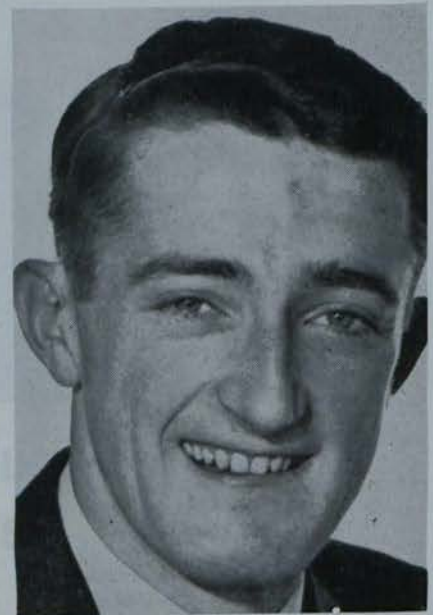

Twenty-one-year-old Mr. Brendan Bracken, who has joined Heatovent Supply Co. as a technical representative. Mr. Bracken worked with H. A. O'Neill Ltd. for two years and then with Matthews & Yates Ltd. of Manchester, where he completed a course in fan engineering.



SPERRYN & CO. LTD.

MOORSOM STREET WORKS · BIRMINGHAM 6

C. B. SHERIDAN.

10, Herbert Place, Dublin, 2.

Agents for the Republic of Ireland
Telephone 66283.

Telephone: ASTon 4011 (6 lines)
Telex: 33724. Grams: 'Sperryn' Telex B'ham.
London Office and Warehouse:
131 Great Suffolk St., London, S.E.1.
Telephone: HOP 0131. Telex 24797.

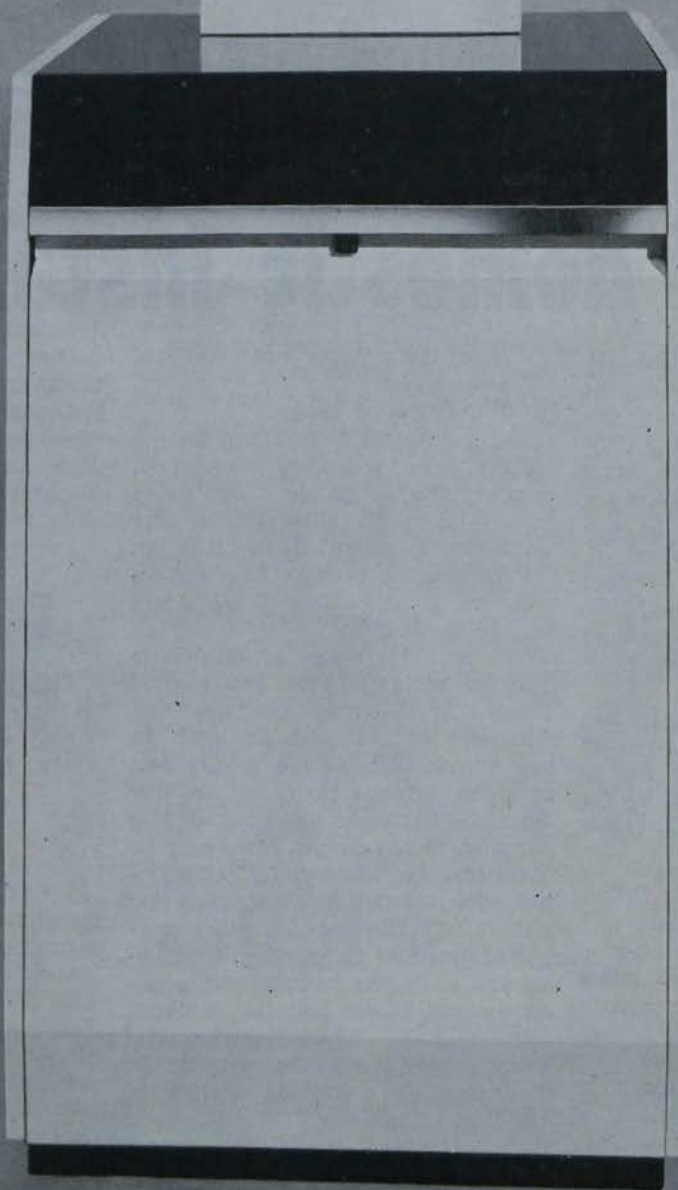

BIGGER INSIDE - SMALLER OUTSIDE

**The BSA Hotspur boiler gives easier access for maintenance
— yet takes up less room**

Once you've installed a B.S.A. Hotspur boiler, bid it a fond farewell. You're unlikely to see it again for a very long time.

B.S.A. Hotspur boilers stay alight. They go on and on like the pub bore (except that you can stop them when you want to and they don't make a noise). For the rare occasions when they need attention, the Hotspur is designed to give really easy access to all parts. Remarkably, it's also smaller.

The heart of the Hotspur is the Torridheet wall-flame burner with built-in draught stabilizer. B.S.A. are the only boiler manufacturers who make their own burners. Its ingenious design uses the fuel-oil as a lubricant, giving years of trouble-free life.

The Hotspur is styled to take pride of place in the kitchen, not to be hidden away in a dark hole. And did we mention that every single B.S.A. Harford boiler is *individually* fired and tested...?

B.S.A.
HARFORD
Northside House,
Mount Pleasant,
Cockfosters,
Herts.

BSA
HARFORD

the 7 deadly sins of domestic installation



IN my last article we established that, in the system under discussion, the heat requirements for the forced circulation and radiators were 33,909, say 34,000, B.t.u./hr. To this figure must be added the emission figure for the bathroom radiator and the circulating pipework that serves it. When this is added, the revised figure becomes approximately 38,500 B.t.u./hr. To refresh your memory the system design is reproduced below.

Once the hot water requirement has been established we will know the precise load that the boiler has to carry, therefore this seems to be the right moment for a little digression into hot water allowances.



Most people allow too much for hot water requirements, 20,000 B.t.u./hr. in a small household is not uncommon. These high allowances used not to matter, but with modern boilers, underloading can be a grave error. The hot water allowance should cover:

(a) The constant or "standby" losses

from the cylinder and associated pipework.

(b) The estimated usage.

Small domestic installations do not usually have secondary circulation, certainly this design does not; losses from a lagged 40 gallon cylinder may be taken as about 2,000 B.t.u./hr. In this case the primary flow and return are so short that these losses may be ignored.

The probable usage is difficult to estimate accurately; the best method I know is based on the size and frequency of the peak demand. In any household there are usually two or three different hours of the day when the hot water system is used to capacity. For example, there may be two baths, i.e., about thirty gallons of hot water, needed between seven and eight a.m. Allowing a further margin of one-third for shaving, washing-up and so on, we find that our greatest demand in one hour is for about forty gallons. There might not be another peak until the evening, or there might be a washing machine in use later in the day. For domestic work, except in special cases, most designers work on a four-hour peak frequency or recovery period.

Our allowance, therefore, would work out as follows:—

Peak demand=40,000 B.t.u./hr. (i.e., 40 gallons).

Time allowed for recovery—4 hours.

Therefore hourly input should be $40,000 = 10,000$ B.t.u./hr.

4

Plus standby losses — 2,000
Total hourly allowance—12,000 B.t.u./hr.

This is a nice tidy, logical method, certainly its the best I know. There is only one thing wrong with it—the answer is not really correct!



Digressing still further, many years ago I was involved in the installation of solid fuel cookers, of a particular type, which had a very limited hot water output—rather less than 5,000 B.t.u./hr. With a short flow and return, and a well-lagged cylinder, one of these units would comfortably supply hot water for a family of four. Or take the homely immersion heater; a 3 k.w. heater gives just over 10,000 B.t.u./hr.—have you got one and how many hours a day do you need to have it on?

Taking it a stage further, I can think of at least one leading boiler manufacturer and at least one impartial official authority who has stated that in certain circumstances the hot water allowance may be completely omitted. Space does not permit a full discussion of pro's and con's; a reasonable allowance, and a compromise between the two extremes, in this case, would be about 8,000 B.t.u./hr. This, added to the rest of the load on the boiler, gives us 46,500 B.t.u./hr.

And now, what boiler do we connect?

Oddly enough, this depends on the fuel. Long ago, when only solid fuel was used for domestic heating, the

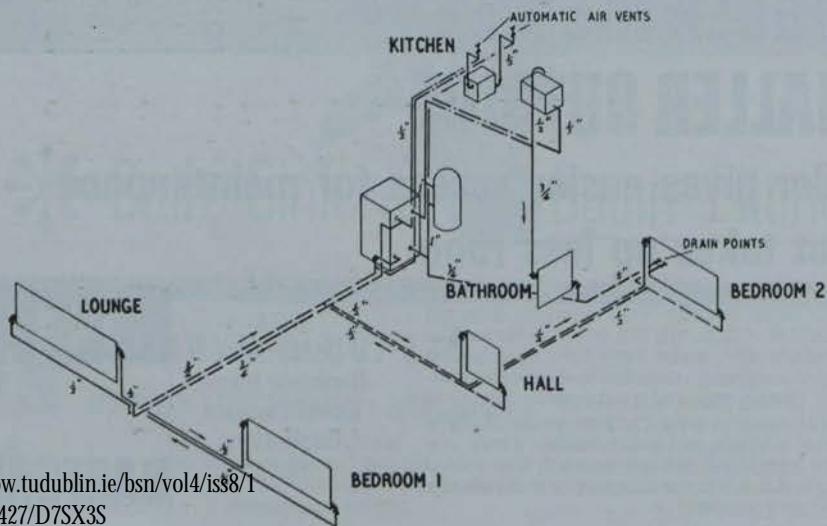

practice arose of allowing a "margin," usually 25%, on the boiler. This was, and still is, perfectly reasonable for most cases where solid fuel boilers are used. Gravity, or magazine, feed boilers do not normally need such a margin but in other cases some allowance must be made for irregularities in stoking or ash clearance, quite apart from minor variations in the ash content and calorific value of the fuels employed. It is unfortunate that, although oil and gas-fired boilers are so widely used now, many designers still allow the margin that was intended for solid fuel. It is sometimes argued that a large margin provides for quick recovery of the system, or for increased output in particularly cold weather. But a boiler can only release heat via the radiators, so a margin in excess of the radiator emission capacity can never be used.



If we look more closely at what happens in an underloaded oil or gas-fired system, especially if the boiler is fully automatic, it becomes evident that the boiler will generate heat rather faster than the system can accept it. The temperature will rise in the circulating water, not necessarily

domestic installation

from page ten.

in the house, and the boiler will cut out after quite a short run. This cycle will be repeated at short intervals; what happens to the overworked ignition system is nobody's business, and combustion conditions will be generally unsatisfactory.

Another digression (this subject fascinates me); one of the problems with modern boilers is the **control medium**. By this, I mean that it is a bit hard on a boiler if one tries to control it by the temperature of the water within the boiler itself; this is especially true if the boiler is underloaded, so that the temperature rises before the heat can be dispersed via the system. Years ago, boilers were massive cast iron affairs with a large water content. These were incapable of the rapid temperature changes which can occur with modern steel boilers containing, perhaps, less than a gallon. The best control medium is the end product in terms of heat, either the air in the house or the water in the cylinder;

ideally, the boiler thermostat should be used as a high limit control only. I shall say more about this in a forthcoming section on controls but this point will bear repetition.

In short, therefore, oversized automatic boilers do nobody any good, unless the radiators can accept the output it can never be used; if the radiators can accept the output, then, by definition the boiler cannot be oversized.



Getting back to this particular design, obviously we have to work to catalogue sizes which are normally in increments of five or ten thousand B.t.u./hr. So, with our loading of 38,500 B.t.u./hr. plus 8,000 B.t.u./hr., i.e., 46,500 B.t.u./hr., the nearest sizeup is 50,000 B.t.u./hr., and we would, in fact, be quite safe in using a 45,000 B.t.u./hr. boiler provided it was "up to its rating." A 50,000 B.t.u./hr. boiler would not be too large; one rated at sixty thousand would be, in my opinion, unless, of course, it was a hand fired solid fuel appliance.

And now, with our design complete, next month we can talk in general terms about controls.

(TO BE CONTINUED)

INTERNATIONAL **Capital** PRESSED STEEL RADIATORS

In Single and Double Panels

- ★ Manufactured in accordance with British Standard BS 3528 and tested to 100 lbs. per square inch (7 Kg/cm²).
- ★ Suitable for use on closed circuit heating installations only, and should not be used on direct domestic hot water circuits or on steam.
- ★ Made from 18 swg (1.219 mm) steel specially supplied for the purpose.

EX STOCK DUBLIN

- ★ Also — THERMOPAK, SILENTFLO, MULTIFLO and THERMOFLO Accelerator Pumps from stock.
- ★ We also carry large stocks of Radiator Valves by all leading makers.

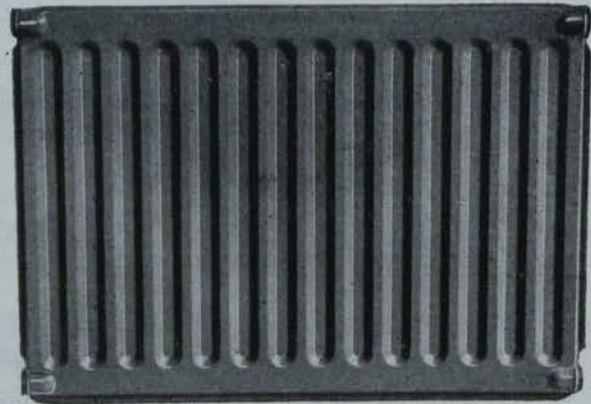

Price list and illustrated leaflets on request

Sole Agents for Republic of Ireland:

MONSELL MITCHELL & CO., LTD.

67-73 TOWNSEND STREET, DUBLIN, 2. 'Phone 76282.

The Irish Plumbing and Heating Engineer.

Unanimous-Whichever way you look at it the **LYNX** is today's most popular cistern

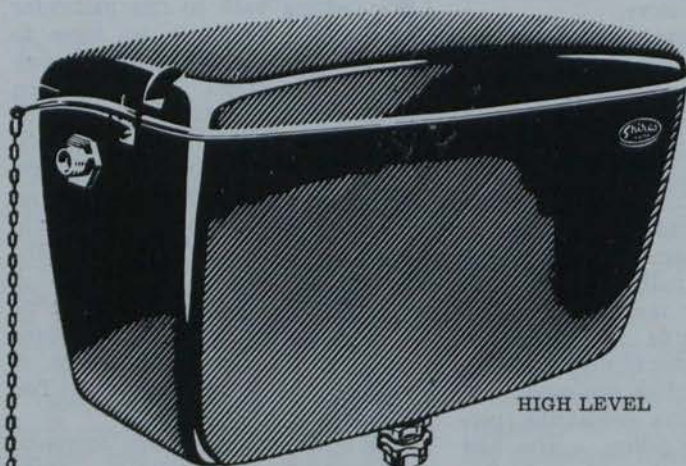

GOOD LOOKING
The Lynx's clean cut lines are an example of contemporary styling at its very best.

PRACTICAL
The Lynx is the easiest to install; the concealed fitting is neat and simple.

EFFICIENT
Discreetly quiet with the most dependable mechanism ever.

Lynx high and low level cisterns are made of tough durable black Duranite that won't craze, is non-corrosive. The Kingfisher siphon mechanism, made of polythene, gives a powerful flush, is non-corrosive, unbreakable. It can be used in both hard and soft water areas. The Lynx conforms to BSS 1125 and Water Works specifications.

Every genuine Lynx has the name engraved on the cistern

Other Shires products are the Uni-Lynx close-coupled suite, cistern fittings, plastic flushpipes and the Polyfloat cistern float.

Available from all recognised builders' providers in the Republic.



made by
Shires
in Ireland

SHIRES (IRELAND) LIMITED Stannaway Drive Crumlin Dublin

trade Topics

WHAT is claimed to be the first surface thermometer on the market designed specifically for small bore central heating systems is introduced by

the British Rototherm Co. Ltd. Using this instrument, it is a simple matter to check on boiler efficiency or heat loss from circulating pipes. It is also helpful when calculating radiator output and balancing systems to the desired value.

The thermometer—Model 907—has a saddle grooved to fit the $\frac{1}{2}$ in. or $\frac{3}{4}$ in. B.S.S. 659 small bore pipe diameters. A special feature of this saddle is that it can be rotated to keep the dial upright whatever the angle of the pipe. A phosphor bronze spring clip, curved to fit flush to these pipe sizes, clamps to the sides of the saddle, holding the instrument in place.

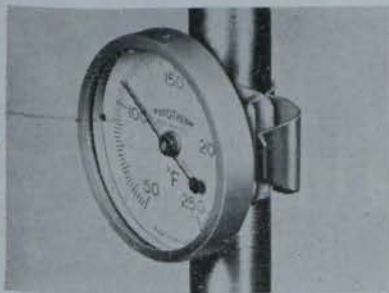

The new thermometer.

It has a clearly marked $1\frac{1}{4}$ in. diameter dial with a stainless steel case. The thermometer is easy to use even in restricted spaces as the spring clip is slipped round the back of the pipe and the thermometer clamped on from the front. The standard temperature range is $50^{\circ}/250^{\circ}\text{F}$ ($10^{\circ}/120\text{C}^{\circ}$). Irish office: The Rototherm Precision and Instrument Co. Ltd.

* * *

PATTON Engineering Enterprises, 30 St. Anne's Road, Drumcondra, Dublin 9, announce that they have been appointed agents in the Republic of Ireland for Perry Heating Appliances Limited, manufacturers of Supermatic

oil fired radiators.

The Supermatic range of Wall Flame oil-fired boilers includes 13 standard models plus 5 de luxe versions and their outputs vary from 44,000 to 300,000 B.t.u./hr. The Supermatic industrial oil fired air heaters are rated

from 250,000 B.t.u./hr. output to 500,000 B.t.u./hr. output and will provide heating by means of warm air circulation for premises from 55,000 to 110,000 cubic feet capacity.

They don't let you D O W N at Wilsons

Every Wilson oil-fired boiler is fired and tested for you before it leaves the works. The outputs are guaranteed, tested outputs into water. Every Wilson radiator has a guaranteed emission figure—a figure calculated to B.S. : 3528 : 1962 by the Heating and Ventilating Research Association, Bracknell. All boilers are very accessible for your checking and cleaning—saves you time on the job. And if there is trouble with a Wilson installation, we do want to hear about it. Because it is not our custom to assume that the installer must be at fault.

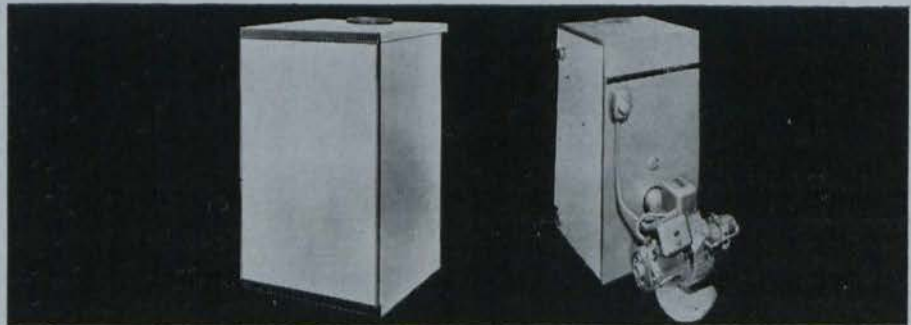

Wilson Wallflame. Five models available with outputs from 45 to 150 thousand B.T.U. Advanced technical design without frills. The biggest selling wallflame boiler in the country.

Wilson Boiler/Burner Units. Pressure-jet fired. Outputs from 70 to 800 thousand B.T.U. Larger models now with Wilson Cosytube baffle for maximum corrosion-free life.



Wilson Radiators. Their extra slim design makes them favourites with housewives. 816 sizes, with standard popular range for quick delivery.



Full details from

Henry Wilson & Co. Ltd.
Sales & Service Office, George A. Reid Esq.,
16, Fade Street, Dublin.
Telephone: 76009.

*The warm hearted tale
of 280 old folk
5 gardener-handymen
and 15 boilers named Allied*



County Architect R. F. FAIRHURST, Dipl. Arch. (L'pool) A.R.I.B.A.,
A.M.T.P.I. Installed by T. H. HASKETT, LITTLEDEAN.

It happened when the Gloucestershire County Council built five homes to house 280 old people—like this one at Arle, near Cheltenham. Old people need warmth more than the young. Like the young they need constant hot water. These homes had to make sure they got both—without heavy fuel bills. Because each has only one gardener-handyman to do all the man's work from fuse mending to flower raising, these homes also had to have a heating and hot water system as work-free as possible. This was the tall order the County Architect Department handed to Allied Ironfounders. They chose Allied for many reasons—not the least being that Allied offer the biggest choice of large boilers—oil-fired, gas or solid fuel. And that they could rely on Allied for the most experienced advice. The happy ending to the story came in the form of 15 Allied Automatic Magazine anthracite boilers—one for hot water and two for central heating in each home. Over the past year, with its terrible winter, each set of boilers has never needed more than one hour's attention each day and has used much less fuel than expected. (In Arle House the total consumption was just over 82 tons for the year.) *Similar Allied boilers have recently been installed in 31 Schools, 8 Welfare buildings, 6 Police Stations, 5 Council Buildings, 10 Clubs, 17 Factories, 19 Hotels and 13 Churches.*

INDUSTRIAL BOILERS ARE MADE BY ALLIED IRONFOUNDERS 

<https://arrow.tudublin.ie/bsn/vol4/iss8/1>
DOI: 10.21427/D7SX3S

Allied Ironfounders Ltd Industrial Heating Division Cadbury Road Sunbury-on-Thames Middlesex Tel: Sunbury 5577

BELFAST OFFICE: M A Graham Esq 20 Bedford Street Belfast 2 Telephone: 29087

industrial heating & ventilating

IN IRELAND



No. 11—Presented with the November, 1964, issue of the Irish Plumbing and Heating Engineer.

A UNIQUE BOILER-TUBE CLEANING UNIT!

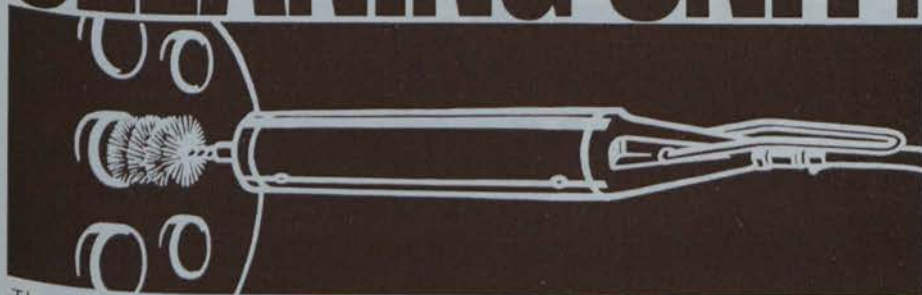

The Ferret is a completely unique type of boiler-tube cleaning unit. Attach it to a standard tube brush and it will creep along the tube—without revolving—and without any need for manual pushing and pulling! When it reaches the tube end, the double thrust action then reverses and the Ferret returns—ready for the next tube!

- THE FERRET**
- *Cuts labour time—no manual pushing and pulling
 - *Does away with extension rods.
 - *Gives cleaner tubes.
 - *Works quickly.

For Publication No. 208, or a demonstration in your own plant, contact:

HALPIN & HAYWARD LTD.,

Published by ARROW@TU Dublin, 1964

16/17 Lower O'Connell Street, Dublin, Eire. Dublin 48638/9.

Last month the Department for Transport and Power, in conjunction with the National Industrial Fuel Efficiency Service, London, organised a successful three-day fuel efficiency conference in Dublin.

A picture-report of the event appears in this industrial section together with observations from the many interesting papers delivered at the conference.

This month's Special Review deals with dust and waste collecting plant. The introductory article to this review has been compiled in two parts, the second of which will be published next month.

An equipment review in conjunction with this Special Survey deals with introductions and developments in the fields covered.

*

EDITORIAL AND ADVERTISING OFFICES:

Callaghan Chambers, 13/15
Dame Street, Dublin 2.
Tel.: 56465-6.

London: J. T. Robson &
Son, Ltd., 30 Fleet Street,
London, E.C.4. Tel.: Fleet
Street 4438.

Belfast: Allen McDowell, 43
Horn Drive, Belfast 11.
'Phone 614606.



The Irish Plumbing and Heating Engineer.

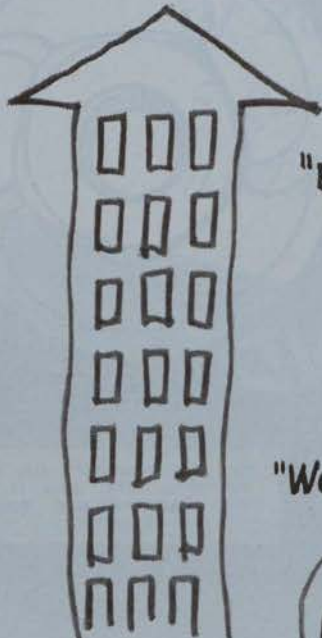

"Booster pumps"
they said—

"Worthington-Simpson"
they said



... because they know that there's no substitute for experience. Many installations point to our specialisation in booster pumps for high density buildings and flats. Dependability, ease of installation, and low maintenance are high on the list of reasons why Worthington-Simpson 'Monobloc' and centrifugal pumps are specified. We also have a wide range of pumps for boiler feed, hot water circulation and other services.

Full information and literature is available on request.

Worthington-Simpson Ltd

20 HERBERT PLACE DUBLIN

**Pumps • Compressors
Heat Exchange Equipment**



P9335

**6 BRANCHES
THROUGHOUT
IRELAND**



You can now take advantage of six service branches in Ireland. Another addition to the extensive after sales network throughout Ireland.

CLYDE

**GEN-O-THERM
AIR HEATERS**

- FULLY AUTOMATIC • RAPID TEMPERATURE RISE • FLEXIBLE HEAT DELIVERY • CONTROLLED AIR CIRCULATION • RELIABLE AND EFFICIENT • THE MOST EFFECTIVE METHOD OF HEATING LARGE BUILDINGS
- HORIZONTAL UNITS USING LIGHT OR HEAVY FUEL OILS CAN ALSO BE SUPPLIED

SIZES AVAILABLE

Heat output	Model
150,000 BTU's/Hour	CH 1
250,000 BTU's/Hour	CH 2
400,000 BTU's/Hour	CH 3
550,000 BTU's/Hour	CH 3A
700,000 BTU's/Hour	CH 4

For full details write to:—

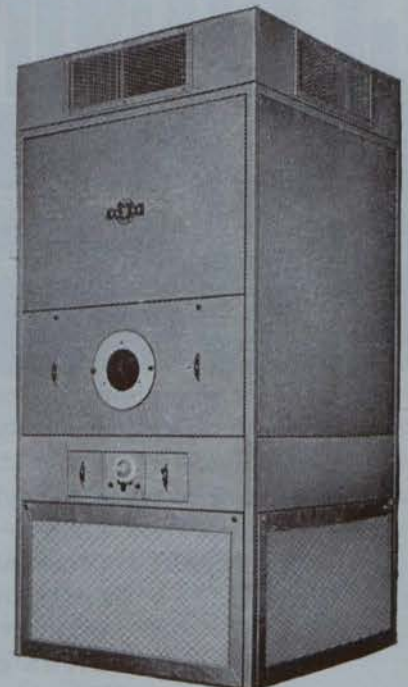

CLYDE FUEL SYSTEMS LTD.

80 Hollywood Road, Belfast. Tel.: Belfast 65365/6.

Branch at Londonderry.

CLYDE FUEL SYSTEMS (IRELAND) LTD.

6 Mount Crescent, Dublin. Tel.: Dublin 66489.

Branches at Cork, Limerick and Longford.

TROX *air distribution equipment*

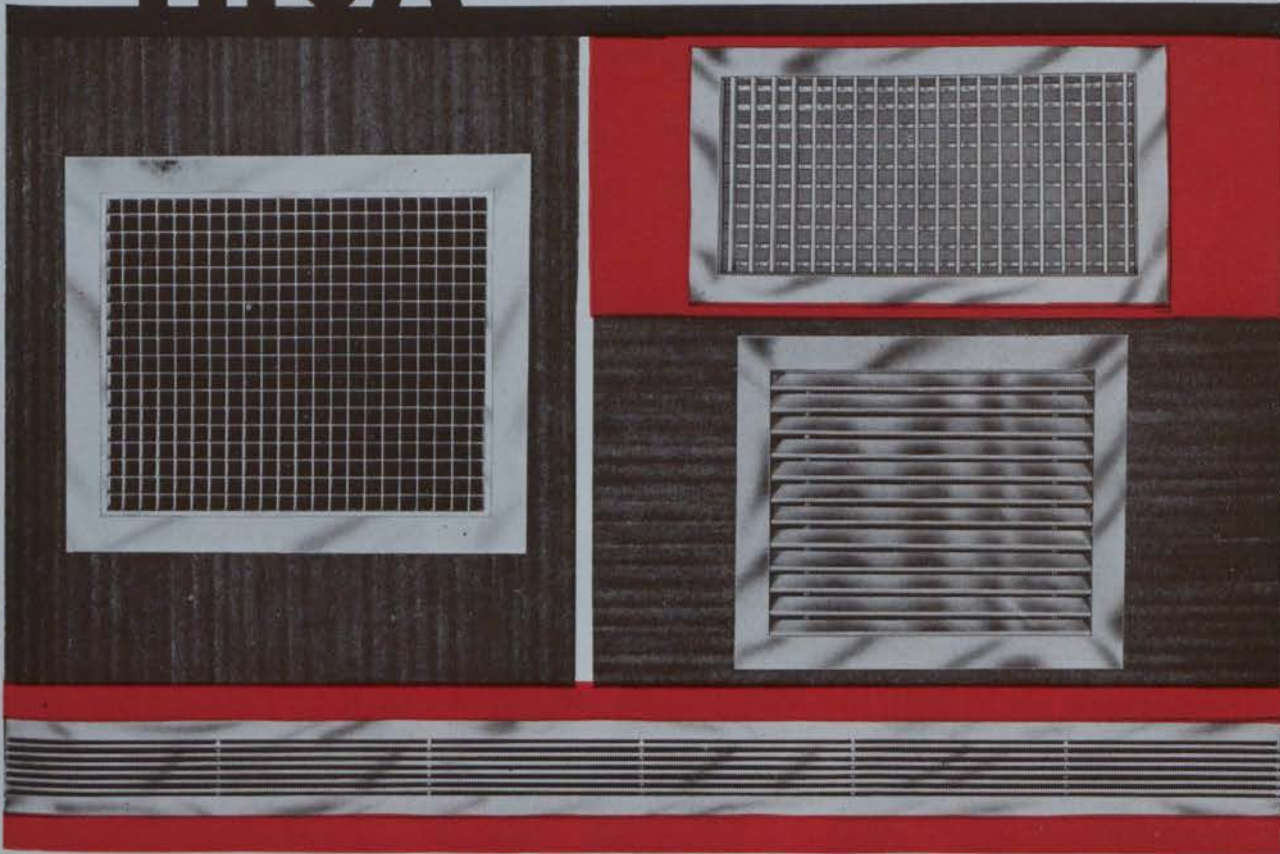

EXTRUDED ALUMINIUM GRILLES WITH SECRET FASTENING

Manufactured from solid extrusions, TROX high quality aluminium registers and grilles feature the unique TROX secret fastening device. Their fine finish and elegant design enhance the architectural merit of any modern building, while their performance versatility enables the most critical air distribution requirements to be fulfilled.

Every item in the comprehensive range of TROX equipment is a well designed, high quality product. TROX technical facilities are available to offer recommendations for all special requirements.

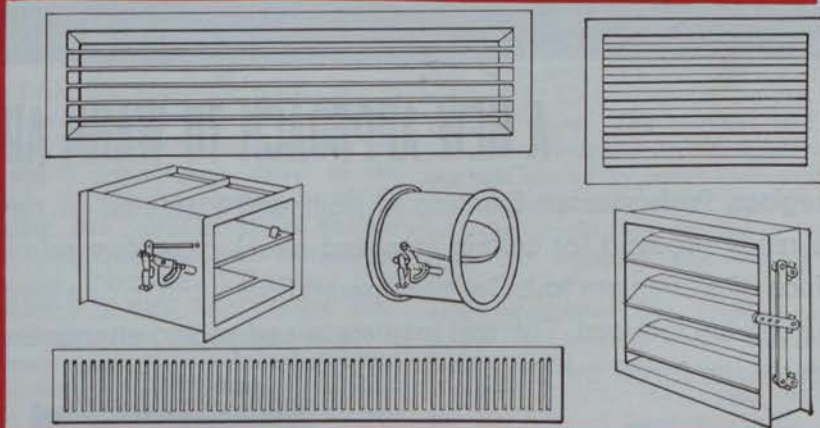

TROX

TROX BROTHERS LTD 238-240 Bethnal Green Road, London, E2
 Agents for Ireland: W. Finucane & Co. 5 Upper Pembroke St., Dublin Tel: 63634
 AUSTRIA · BELGIUM · FRANCE · HOLLAND · ITALY · SCANDINAVIA · SWITZERLAND · W. GERMANY



A NEW APPROACH TO WARM AIR DUCTING

Fibreglass Prefabricated Ducting is built and insulated in one operation. It's a rigid slab (available ready grooved for certain standard sizes) or preformed circular duct, with an attractive outer surface of aluminium foil. On-site operations are cut to one simple assembly, so installation costs are considerably reduced. Thermal insulation and sound attenuation properties are excellent.

Please write for all the details to:



**Fibreglass
Limited**

21, MERRION SQUARE NORTH, DUBLIN

MONSELL MITCHELL & CO LTD

Sole Distributors of Fibreglass Heat Insulation Products in the Republic of Ireland.

JAMES RYAN (DUBLIN) & CO LTD

Sole Stockists of Fibreglass Air Filters in the Republic of Ireland.



Mr. Erskine Childers, Irish Minister for Transport and Power, pictured opening the Conference. It was the first time such a conference has been held in Ireland. Also in the picture are (from left): Mr. N. O'Brien, Principal Officer, Fuel and Power Division, Department of Transport and Power; Sir Leslie Hollinghurst, Chairman of N.I.F.E.S.; Mr. S. C. Ginn, Managing Director of N.I.F.E.S. **SECOND PICTURE** shows (left to right): W. C. Beattie, Assistant Engineer to N.I.F.E.S.; H. Brown, Area Manager for Ireland, N.I.F.E.S.; T. David, Spirax-Sarco Ltd.; M. J. Dickson, Senior Engineer, N.I.F.E.S.; Mr. P. Liuzzi, Halpin & Hayward Ltd.

FUEL EFFICIENCY CONFERENCE WAS WELL ATTENDED

At least £1,000,000 could be sliced off the national fuel bill by the use of more up-to-date systems in such places as hospitals, schools, hotels, factories and even in the domestic sphere.

The Minister for Transport and Power, Mr. Childers, said this when he opened the highly successful three-day conference on Modern Techniques in Fuel Efficiency in the Dublin Intercontinental Hotel last month.

The conference was sponsored by the Department under the direction of the National Industrial Fuel Efficiency Service (NIFES), London. The Government's fuel efficiency campaign being operated with the aid of NIFES, has been running since 1961. Grants of up to half the cost of fuel efficiency surveys are available.

MR. CHILDERS was introduced by the conference chairman, Sir Leslie Hollinghurst, G.B.E., K.C.B., D.F.C., chairman of NIFES. The Minister's theme was the importance of fuel efficiency in the future as a means of keeping costs as low as possible.

The object of the conference, said Mr. Childers, was to give industrialists a chance to exchange views and discuss modern developments on fuel technology. In this country, we produced relatively little fuel, considering our population. Fuel imports were at the rate of £25,000,000 a year, and we could expect an increase of about one-

third of this figure, in the next ten years. This meant, said Mr. Childers, that fuel efficiency had become very important, to keep bills as low as possible, and he hoped that fuel engineers would study the problem very thoroughly.

The Minister also spoke on the programme for economic expansion, and said that a deep study had been made of each industry and its expansion. They could not afford to have wasteful fuel systems, and at least £1,000,000 a year fuel costs could be saved by the use of more modern systems, in such places as hospitals, hotels, schools, offices and even in the domestic sphere. In the home, he said, economy grates could keep down costs.

SPEAKING about the work done in promoting greater fuel efficiency since 1961, the Minister said this included a promotional drive in the course of which an inspection of the heating and power plants of various industrial firms had been carried out by the National Industrial Fuel Efficiency Service, and reports confirmed the scope for saving fuel costs, in some cases showing that they could be achieved by inexpensive modification of existing plants, and by improved boiler house procedures.

In order to encourage firms to avail of the advisory services, provided by fuel efficiency consultants, Mr. Childers said grants of up to one half of the

cost of surveys were available from his department. He wished to emphasise that this consultancy work was open to all, and he would like to see Irish consultancy firms play a full part in the surveys. If these showed that substantial expenditure was called for on adaptation or replacement of plant, the firm might qualify for a grant from An Foras Tionscal, or a special loan from the Industrial Credit Company.

IN the majority of cases, the capital expenditure needed to achieve better performance was not great, and would be recovered in a few years by saving on fuel. Since May, 1962, 40 applications for survey grants had been approved, compared with a total of 22 applications in the preceding five years. The Minister said he felt sure delegates would appreciate the role played by boiler operators in the efficient operation of plants, and said they might be interested to learn that the National Industrial Fuel Efficiency Service were making available throughout this country their course for training boiler operators, which would bring them up to a standard at which they would qualify for the City of London Guilds Institute certificate. The first course was now being organised in Galway.

Sir Leslie Hollinghurst thanked the Minister.

During the three-day conference a series of most informative and interesting papers were read. Here we publish observations from these papers.

The Scope for Fuel Efficiency In Ireland (H. Brown, Esq., A.M.Inst. Gas. E., M.Inst. F., Area Manager, N.I.F.E.S., Belfast, 1).

Potential Savings.—A yard-stick for the determination of optimum efficiencies was given, also the skills required in a fuel engineer to interpret the findings and produce a comprehensive report. Reference was made to various visible signs of inefficiency: steam vapour to atmosphere, heat losses, water analysis, air vents and combustion losses.

Fuel Efficiency and Productivity (R. Clare, Esq., B.Sc., M.Inst.F., Area Manager, N.I.F.E.S., Manchester).—It was stressed that although a reduction in fuel consumption is extremely important as a means of keeping down costs, it is often more important to obtain increased production for the same fuel consumption. The fallacy of assessing the importance of fuel in terms of the percentage of total manufacturing costs was discussed.

The Industrial Uses of Peat (F. Lunny, Esq., B.E., M.Inst.F., Chief Fuel Technologist, Bord Na Mona).—An outline was given on the origin and use of fuels down through the ages and its conversion into high grade heat. The physical structure of turf was discussed and the chemical and physical properties supplied in tabulated form. Basic requirements for efficient combustion were enumerated and heat outputs per unit were spotlighted. The development and methods of mechanical stoking were gone into.

Coal and the Commercial Consumer (J. Menheneott, Esq., M.B.E., Deputy Director General of Marketing, National Coal Board, Dublin).—The benefits which British Coal now has to offer were stated and the part played by mechanisation and its contribution to an increase in productivity were discussed in terms of benefits for the industrial consumer. It was shown that in order to compete with oil it has been the intention to make coal more competitive in terms of price, quality and service. A market of 200 million tons per year is the target. Mention is made of co-operation between the Board, manufacturers and the British Coal Utilisation Research Association so that new boiler plant and handling equip-

ment capable of high efficiency and a high degree of automation should be developed. Particular reference is made to the development of Corner Tube boilers.

Modern Oil Burning (by C. A. Roast, Esq., A.M.I.Mech.E., A.M.I.E.E., F.Inst.F., Esso Petroleum Company, Ltd.).—The approach to choice of fuel was dealt with. Diversification of sources of supply was discussed. The characteristics of the four basic grades of fuel oil were given in tabular form. Resolving of problems relating to flue gas losses was gone into and conversion from solid fuel to oil fuel firing was examined. Recommended grades of oil fuel for various boiler ratings were quoted.

Interpretation and Analysis of Works Records (R. Clare, Esq., B.Sc., M.Inst.F., Area Manager, N.I.F.E.S., Manchester).—Stress was laid on the necessity of analysing collected data in the form of charts, records, log sheets, internal statistics and cost records. Too often, such data is only given a cursory glance and then stock piled. It is only by critical examination with an expert eye that daily, weekly or annual trends can be estimated. The first problem should be to consider the relationships between the various items of information recorded.

Waste Heat Recovery (H. B. Weston, Esq., A.M.I.Mech.E., M.Inst.F., Deputy Area Engineer, N.I.F.E.S., Manchester).—This paper dealt with brewing, low temperature processes, textiles and furnaces. The utilisation of waste heat from brewing coppers, wort coolers, barrel and cask washing and boiler flue gases was among the subjects examined.

Town's Gas and Its Industrial Uses (Thomas E. Dunphy, M.E., A.M.I. Mech.E., A.M.I. Chem.E., M.I.Gas.E., General Manager, Metal Products Limited, Cork).—Only the more interesting points in a relatively long history of utilization and application were gone into. In the last few years a come-back has been staged in the field of motivation by Thermo electric cells, Gas Turbines and the modern high speed internal combustion engine. On a thermal basis, a comparison was shown between gas, electricity and oil. The overall efficiency was shown as the

heat transferred into work as a percentage of the heat of combustion of fuel used. Factors governing heat transfer were also enumerated. The basic considerations which must be satisfied in any industrial problem were discussed, likewise the relevant points which can be made in favour of gas.

Utilisation of Electricity In Industry (C. H. O'Reilly, Esq., B.E., A.M.I.E.E., Electricity Supply Board).—Various aspects in the utilisation of electrical energy in which greater efficiency may be obtained were discussed. Low tension and high tension distribution were discussed along with the requisite equipment. The economics in relation to distribution costs were dealt with as were the various necessary protective devices in primary and secondary circuits. Other aspects dealt with were: motors, power factor, heating, lighting, and load factor.

Hot Water Central Heating Plants (W. Short, Esq., B.Sc., M.Inst.F., A.M.I.H.V.E., Area Engineer, N.I.F.E.S., Cardiff).—The relationship between thermal efficiency, thermal rating and load variation was illustrated. Gravity feed, oil fired and combined domestic hot water-heating boilers, etc., were fully described. Acid dew point corrosion problems peculiar to hot water boilers and methods of prevention were also considered.

Medium Sized Boiler Plant (H. Pollard, Esq., A.M.I.Mech.E., A.M.Inst.F., Deputy Area Manager, North Eastern Area, Leeds).—The term "medium sized" was chosen to cover boilers in the range of 4,000 lb./hr. to 60,000 lb./hr., and developments during recent years, which have been more rapid on the Continent, were referred to. These developments, both by improving conventional designs and producing new appliances, have had the objects of improving efficiency, reducing capital costs, conserving space and reducing operational costs. In Britain, the Clean Air Act has accelerated developments and research by manufacturers, the fuel industries and others has led to packaged coal and oil fired plants, incorporating simplicity, reliability and automatic control being produced.

Revolutionary!



is the NEW Buderus P22

***Revolutionary also the delivery position of
Buderus boilers: over twenty different outputs from
Dublin stock in domestic to large factory sizes.
And—Steel Column Radiators in Nine Different Heights
and Widths!***

★ For Heating In A Hurry

Telephone 693940 and 693943 Telegrams Halo Dublin.

QUADRANT ENGINEERS

167 STRAND ROAD, MERRION GATES, SANDYMOUNT, DUBLIN 4.





MONTHLY
**SPECIAL
REVIEW**

DUST AND WASTE
COLLECTING PLANT

INCINERATION MOST ADVANCED WASTE DISPOSAL METHOD

THE disposal of refuse of almost any kind by incineration is acknowledged to be the most advanced method, both from an economic as well as from a sanitary point of view. The opportunities to effect incineration or the combustion of refuse we call an "Incinerator" or "Destructor."

Regarding the difference between an Incinerator or Destructor, there is no scientific or technical difference between both. Either can be called or named a "refuse furnace." What one person calls a destructor, another calls an incinerator, or someone else calls a "refuse furnace" or "disposal furnace." The word Incinerator is generally accepted as the most appropriate term for the apparatus used for the disposal of refuse garbage, etc. The word "Incinerator" is our preference as it hits the nail squarely on the head and will be used together with "refuse furnace" no matter whether the small household incinerator or the flue fed incinerator or the large forced draught installation is referred to.

The only distinction between the various sizes and types of incinerators are the means used to provide proper conditions necessary to assure the most complete incineration of combustion process.

IN our description we will refrain from going into any technical details as they may only cloud the issue and take from the purpose of the details.

Incineration is a combustion process subject to the same principles as prevail in combustion of any other substance. It is a combination of oxygen contained in the air with the combustible products contained in the refuse or waste. Whether the refuse is wet or dry or whether it is mixed with non-combustible material does not alter the

case as far as the fundamental requirements are concerned. The mixtures of wet and dry only render it more difficult to provide favourable combustion conditions and so requires a more careful and close observation of all conditions basic to a complete combustion process. The recognition of this fact is most important and must be clearly understood by anyone connected with the design or specification of incineration. There is nothing mysterious or secretive about incineration as often the layman or even the Engineer believes or is made to believe.

WHAT Is An Incinerator?—The incinerator is simply a furnace designed to provide proper conditions for the combustion process of a material having a low fuel value and a mixture of a large portion of incombustible material or moisture.

To obtain efficient complete combustion three very salient points must be considered:—

1. Oxygen must be present in the right amount to combine with incombustible matter.
2. Combustible matter and oxygen must be in the closest possible contact to effect a combustible combination.
3. Sufficiently high temperature must prevail to assure the complete combination of oxygen and combustibles (ignition and combustible temperatures).

Each and all of these requirements must be met even in adverse conditions in order to assure completeness of the combustion process. Complete and rapid combustion is of the utmost importance to an efficient odourless combination process.

Development of modern incinerator design.—The original conception of incinerator design was based upon the thought that the refuse, especially the

wet portion, should at least be partially dried out before it was placed on the grate for burning. The heat generated by the burning of the pre-dried portion should be utilised to dry the freshly fed material by leading the furnace gases over or under the wet material. While this may be possible, it cannot be achieved in an incinerator without endangering the completeness of the combustion process, resulting in an inefficient and incomplete incineration.

A closer look at this process will reveal the inefficiency of the method. The flue gases from the burning material in the space chamber travelling over the wet refuse have to give up a great part of their heat to evaporate the moisture and also to distil out the volatiles contained in the fresh material. Thus the temperature is lowered to such an extent that ignition of the rising gases is at least very uncertain.

THIS condition is aggravated by the fact that the malodorous gases are liberated before the moisture is evaporated. The distillation of these volatiles takes place at the far end of the drying arch, at the point where the flue gases are the coolest. These gases pass out of the combustion chamber or furnace unburnt, since they lack sufficient high temperature necessary for combustion.

The oxygen necessary for the combustion of the volatiles has to enter through the furnace chamber. This additional amount of air has to be heated to the furnace temperature, which again causes a decided reduction of the temperature in the combustion chamber.

These defects were recognised. There were attempts made to overcome the defects by placing the drying arch in such a position that the

continued page twenty-four

'UNIVEX' PACKAGE BOILER

Steam or Hot Water

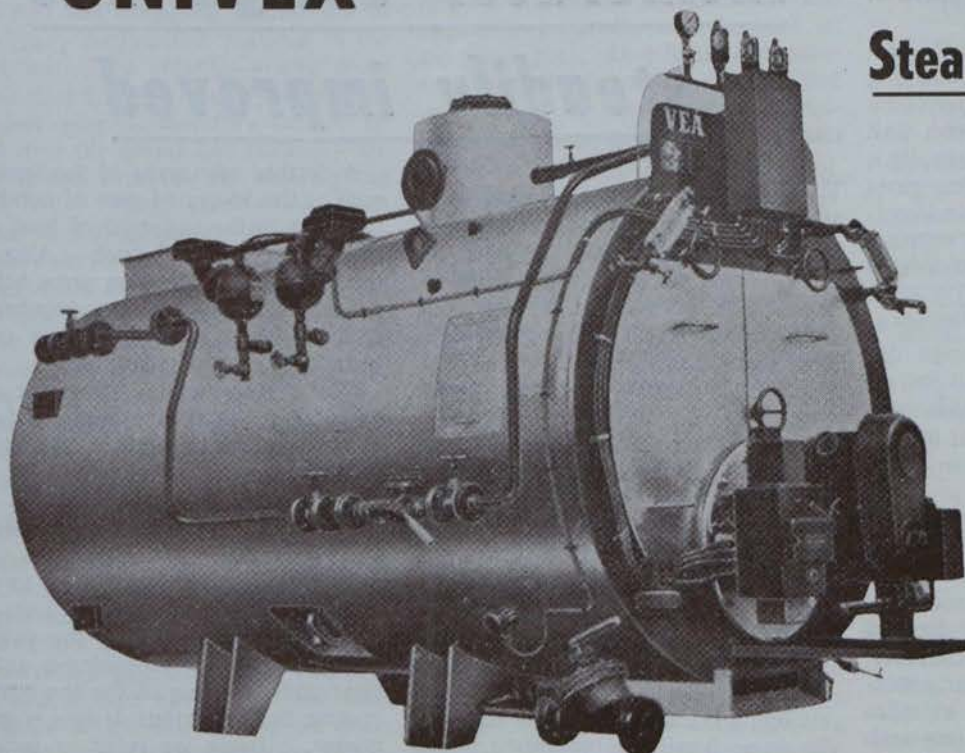

- ★ "Packaged" Unit. Simplified installation.
 - ★ Automatic Safety Equipment.
 - ★ Efficiency up to 90% obtained.
 - ★ Minimum operating attention.
 - ★ Simplified Boiler maintenance.
 - ★ Burns 200 secs. oil without pre-heating.
 - ★ Flanged steel fittings.
- SERVICE** — Factory trained personnel for service.
- ★ Over 40 installations operating satisfactorily in this country.

GOLDEN VALE ENGINEERING DEPT.,
Charleville, Co. Cork. Telephone 255

Ideally suited for
Central Heating
Installations.

compressed air
pipeline filters

by

VOKES

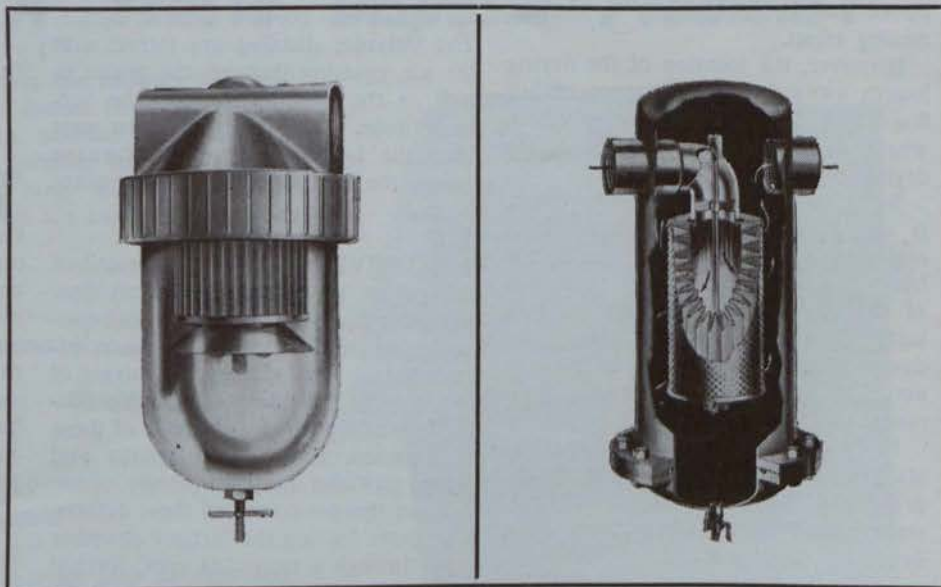

Vokes compressed air pipeline filters are available for vertical or horizontal installation in seven standard sizes to cover lines from $\frac{1}{2}$ in. to 4 in. and pressures up to 500 p.s.i. Custom built filters are also available to meet specific requirements. Vokes also manufacture a filter for use in $\frac{1}{4}$ in., and $\frac{3}{8}$ in. air lines fitted with a transparent bowl to enable the need for servicing to be quickly seen. Write for details.

The Irish Plumbing and Heating Engineer.

from page twenty-two

gases arising from the fresh material had to travel over the fire.

Alfred Fryer of England in 1875 recognised the basic faults of the drying arch and endeavoured to overcome them. In his effort, a partition wall was placed upon the drying arch. This arrangement prevented the flue gases from passing over the refuse and cooling off before they met the volatiles from the raw material. This step was one of the most important solutions in the proper design of incinerators. Unfortunately this design did not give adequate attention to the air admission and failed to provide conditions or means assuring a mixing of the flue gases and air.

THE Fryer design was improved later by Horsfall. Instead of returning the gases alongside the drying arch he passed the flue gases and unburnt volatiles through a laterally located flame port into a combustion chamber. He further provided for an early mixture of the flue gases and volatiles through the use of a low hung arch disposed over the lower end of the drying hearth. Thus he secured a longer travel and better mixture of the distillates with flue gases and air in the furnace chamber. He then introduced the forced draught to aid the mixing effect.

However, the location of the drying hearth away from the passage of hot flue gases defeated the drying effect, which was the original purpose of the drying arch.

So in the next step of development, it was practically omitted. With omission of the drying hearth, the heavy fire beds increased the resistance of the air passage through the fuel bed. To overcome this deficiency, the designers used forced draught. In actual fact this proved more of a hindrance.

In larger plants for municipal installations, etc., the use of forced draught is beneficial. In smaller installations, however, it is more of a detriment than a help.

The step grate design, adapted by

Incinerator design was steadily improved

Joseph Goder of America, to incinerators offered a means of overcoming the hindrance of a heavy fuel bed as both the large spaces between the steps, as well as the inclined position, permitted a progressive drying of the refuse before final burning of the fixed fuel took place.

The material is deposited on the upper part of these grates. The radiation from the burning material on the lower portion affects the drying of the wet material. The inclination of the grate surface permits the use of large spaces between the horizontal grate members without danger of the passage of unburnt material into the ashpit. It also reduces the resistance of the fuel bed, due to its variable thickness.

Comparing this design with the earlier ones, it will be recognised that a furnace of this type in its operation is practically the reverse of the older type. The fuel on the upper portion of the grate area is exposed to the radiant heat from the burning material on the lower portion of the grate. The volatiles distilled are mixed with the air, entering through the grates as well as the opening through the furnace door. The mixture must pass over the hottest part of the furnace where the ignition of the gases takes place.

HOWEVER, the furnace described falls short of being the perfect one, since the distilled volatiles are not concentrated in the area of the most intense heat. Furthermore, the mixing of the air with the flue gases is not sufficiently accomplished. Because of these deficiencies, bad odours, smoke and flying particles may frequently occur.

Later designs corrected these defects. The gases leaving the furnace chamber pass through a restricted area, formed on three sides by projections of the brickwork (so called deflecting surfaces) and on the fourth side by the arch (ignition arch). This restriction of area assures an intimate mixture of the gas streams leaving the furnace chamber, thus assuring closest contact of unconsumed flue gases with air present at the point of highest temperature.

A further advantage of the ignition arch is the increased rate of combustion due to the radiation of heat directly upon the fresh fuel. Also the longer travel of the flue gases before entering the combustion chamber is a decided step towards a most complete and efficient combustion.

We might mention here, at this stage, that one of the best proofs as to the accuracy of these statements is the historical development of the incinerator.

Principles of smokeless and odourless operation.—To determine the probability of an incinerator to operate efficiently and trouble free, the basic features underlying the various designs must be considered and a clear understanding of the combustion process in the various designs is paramount. (Here we refer to incinerators of the Destructor type). These incinerators may be divided into two major classes:—

- (a) Incinerators having drying arches or drying hearths interposed between the actual grate surface and the secondary chamber or flue.
- (b) Incinerators without drying arches or hearths between grate surface and secondary combustion chamber.

THIS distinction is important as their influence on the combustion process is decidedly different. These varied conditions demand a different treatment, primarily of the amount and arrangement of the secondary air admission.

The smoke reduction problem is based on the fundamental principles underlying a complete combustion process, namely:—

- (i) Presence of proper oxygen (air) supply.
- (ii) Intimate contact or mixture of oxygen (air) with both fixed and volatile combustibles.
- (iii) Maintenance of proper ignition temperatures.
- (iv) Sufficient combustion space to provide time completion of the combustion process.

Incinerators of the first type have a restricted primary air supply (air admission).
Continued page twenty-five



This special review article was compiled by . . .

Mr. J. L. Fitzgerald.

mitted through fuel bed) and a comparatively lower temperature in the furnace chamber. This restriction of primary air admission, and the fact that air is only admitted to a part of the fuel bed limits the combustion of the ready combustible material in the fuel bed. The volatiles arising from the refuse lying on the drying hearths do not pass it, therefore cannot ignite over the grates and naturally are not mixed with the air entering the fuel bed. Then combustion takes place at a later point. Also, the necessary air for the combustion of these gases must either travel through the primary combustion chamber, cooling same, or be admitted near or in the secondary combustion chamber. Thus, it is evident that the furnaces of this type demand a larger amount of secondary air than is necessary for incinerators relying on a greater amount of primary air admitted under and into the fuel bed by means of appropriate grates.

The afore-mentioned differences between the two types of incinerators also effect the around and position of auxiliary gas burners. The drying hearth type having a lower temperature at the entrance of the gases into the secondary combustion chamber, demands a source of heat to ig-

SPECIAL REVIEW

from previous page

nite the flue gases. Thus, the demand of auxiliary burners at or in back of the flame port. Due to the comparatively low temperature of the flue gas-air mixture entering the combustion chamber, this secondary heat source must be considerable.

Conditions in the second class of incinerators are entirely different. As the furnace temperature is decidedly higher and the volatiles arising from the fuel bed are already mixed with air admitted through the grate spaces, a favourable condition for combustion of these gases exists at their exit from the fuel bed and their early ignition is thus assured. Any auxiliary heat and oxygen necessary to ignite the volatiles should be applied in the primary chamber.

Thus pre-requisite temperatures and air being present in the primary furnace chamber, it remains to provide an adequate mixing medium to bring air and volatiles in close contact. This can be most efficiently solved by the use of a checkerwork splitting the gas stream into multiple smaller streamlets. This feature will be en-

hanced when the velocity of the gases through the checker opening is suddenly lowered by the expansion of the gases entering a spacious combustion chamber.

(TO BE CONTINUED).

IN this equipment review

we take a long look at new

developments in the fields

covered by this special review.

(All claims are those of the manufacturers).

INCINERATORS manufactured by the famous Joseph Goder firm are designed to meet special conditions such as capacities over 1,500 pounds per hour or other special wastes, wire burning, special space requirements, mechanical charging, etc. Joseph Goder incinerators are now represented in this country by Hendron Bros. (Machinery) Ltd., Little Denmark St., Dublin.

The incinerators, from the firm, now in operation include conveyor charging and travelling chain grate

Continued overleaf

Have You A Waste Disposal Problem?

If you have this problem, we have the answers in Joseph Goder Incinerators. There is a Joseph Goder Incinerator for every waste disposal problem, whether small or large. Joseph Goder Incinerators are designed for Schools, Hospitals, Veterinaries, Supermarkets, large stores, institutions, etc., etc. Joseph Goder Incinerators are designed for perfect incineration by—

- 1 Step Grates**
- 2 Fire brick lined incinerators**
- 3 Inclined charging door with integral cast hopper**
- 4 Sliding grates**
- 5 Cyclo-vane fly ash control**

● Your waste disposal problem is as near as your telephone. We shall be only too pleased to discuss your problem and offer you the perfect solution.

HENDRON BROS. (Machinery) LTD.

9 Little Denmark Street, Dublin. Tel. 40846.



Twenty-five

PRODUCT REVIEW

units. These special units may be combined with standard firing chambers to dispose of ordinary wastes as well.

Gas washers or dry dust collection can be supplied, although emphasis is on the forced draught. The Company manufacture incinerators of every type, ranging from the smallest domestic type to the largest municipal ones. Of the 150 different models available, there is one for every purpose, whether domestic, hospital use, or for supermarkets, etc. The units are supplied completely packaged and incorporate an oil or gas burner as standard equipment, together with safety controls.

* * *

BAHCO Workshop Fan unit FKB, is intended for local exhausting and blasting purposes. The fan can be used either as a fixed or portable unit. The mounting frame is made in such a way that the fan can be located with any face to the floor, wall or ceiling. The frame can also be used as a carrying handle when the unit is being transported.

An important application for this fan is the extraction of welding fumes. For this purpose the fan is supplied with reinforced rubber hoses and a suction hood. The fan is manufactured entirely from sheet steel. The inside of the fan casing is reinforced with a liner of 10 gauge toughened steel. This enables the workshop fan to be used for handling air containing reasonable amounts of abrasive materials, e.g., dust extraction from grinding wheels.

In standard form the fan is provided with an inlet spigot piece for the connection of a hose or a pipe. An inlet wire grille is available as an optional extra should the fan be required for free suction. The fan is directly driven by a totally enclosed, squirrel cage motor for a 220/240 V., 1 ph., 50 c/s. electrical supply.

The Bahco workshop fan, FKB 8, is easily moved between various working sites and can also be used in small and inaccessible places, where the need for effective extraction is especially necessary, e.g., in tanks and pipework. Bahco Ltd. are at Bahco House, 23 Goswell Road, London, E.C.1.

* * *

THE SANIGUARD "Barrywald" type incinerator is a fully automatic unit—all that is required is the depression of the lever on the left hand side of the unit. A most important and essential feature is that under no circumstances can contact be made

from previous page

with the combustion chamber when articles are inserted.

The dimensions of the Barrywald W-2 wall mounting unit are: width, 19"; height, 18"; and depth, 10". The loading is 1 kw. The net weight of the unit is 36.5 lb. and the gross weight is 46.2 lbs. The unit capacity is approximately 220 cu. in. The unit's material is fully cast aluminium and it is finished in stove enamel. The agents in Ireland are Roper Bros. Ltd., 5 South Anne St., Dublin.

* * *

WITH THE range of Bering Kleenaire incinerators, incineration is rapid, hygienic and economical. Bering incinerators, which have been recently improved in minor details, are keenly priced and can smokelessly burn up to 14 cwt. of rubbish daily, even that which is almost completely saturated with moisture.

The principle that enables the Kleenaire range to perform so well is that of reheating the waste. A plentiful supply of primary air is provided to which is added secondary air



A Bahco workshop fan being used to extract welding fumes. The collecting hood is one of the Standard range of accessories.

through ports in the side walls to dispose of unburnt hydro-carbons. Dry rubbish, however, burns naturally at great speed. Dense smoke from damp moisture may be prevented by using a paraffin fuelled reheat booster which is placed beneath the air inlet. The faster burning causes a rapid rise in temperature which dries out the moisture. From Bering Engineering Limited, Doman Road, Camberley, Surrey.

FLOATSWITCHES

for

controlling electrically driven pumps
Limit switches
Liquid level alarms
Motorised valve controls
etc., etc.

MERCURY TUBE and SILVER CONTACT types. Indestructible polystyrene floats. Floatgear also in stainless steel, copper, mild steel and polythene. Deliveries ex stock.

Generous discounts to the trade.

Stocked by most Electrical Wholesalers

Available from the Manufacturers



GIRDLESTONE PUMPS LTD
WOODBRIDGE, SUFFOLK, ENGLAND
Tel.: WOODBRIDGE 660.

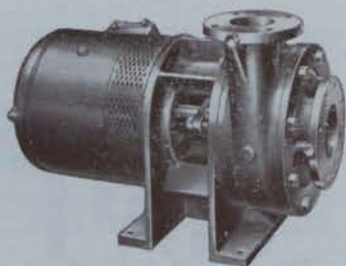

PUMPS

for heating installations of all sizes



Heating engineers find, in the range of Safran Pumps, units exactly adapted to their purpose whether it be for m a m o t h office block, country mansion or two bedroom bungalow systems.



S.C.E. Self contained Electric Sets for horizontal or vertical installation. 9 sizes, duties from 28 to 1,000 g.p.m.

C.C.E. Circulators. Fullway direct-in-pipeline type. 8 sizes, duties up to 110 g.p.m.

SAFRAX C.S.E.G. Circulators. Silent, glandless units for small-bore systems. 4 sizes, duties up to 16 g.p.m.

SAUNDERS VALVE COMPANY LIMITED

Safran Pump Division

DRAYTON STREET, WOLVERHAMTON. Phone: 25531.

smail PUMP SPECIALISTS

FOR ALL YOUR PUMPING REQUIREMENTS CONSULT THE EXPERTS

smail, sons & co., ltd.
21 BRIDGEND, BELFAST
TELEPHONE: BELFAST 51255



THE Tuttle & Bailey Company, Connecticut, U.S.A., have introduced

A NEW EXTRUDED DIFFUSER

the Imperialine 5000 extruded aluminium slot diffuser which is eminently suitable for supply or return air. The Imperialine 5000 is designed for installation in ceilings, walls or cill mounted positions to fit any architectural scheme. It is available from Van den Bosch.

The Imperialine 5000 diffuser is 1½ inches wide x feet long with a slot opening of ¼ inch. The outer margin is a 1" wide flat to overlap the adjacent mounting surface. Wider diffuser units can be assembled in 2, 3 and 4-slot widths which extend up to a 6" nominal width. The number of air openings of slots may be arranged in one way and two-way patterns.

Extended diffuser lengths may be obtained by butting and keying together 8 ft. long units to provide the required length. Air volume is regulated by adjusting the equalising deflector, which is accessible through the slot opening in the diffuser face, or with an inlet duct damper in a rectangular air plenum. The pattern deflector may be adjusted through the slot opening with a removable key for horizontal or vertical air pattern control. * * *

INTRODUCING Continental convection heating by the foremost German

QUADRANT INTRODUCE NEW UNIT

firm, GEA, for the first time in Ireland, Quadrant Engineers can offer very quick delivery of convector elements and unit heaters. The GEA finned tube (illustrated) has many radically new features for the Irish market, especially in its ease of mounting, by robust simple brackets.

The continental concept of total design, opposed to piecemeal assembly

Continued overleaf



from previous page

on site-made fittings, allows these elements to register simply and easily with any architectural fittings or furniture, for example, under or behind seating fixtures, under plate glass windows, or behind wooden wall panels, for which special instant mounting brackets are available at low cost.

Outstanding is the high heat release per foot run available from these compact elements, which are produced in widths from 2" to 12". Details on the new GEA range are available from the sole representatives, Quadrant Engineers, 167 Strand Road, Sandymount, Dublin 4.

* * *

A COMPLETE range of general purpose gauges for the measurement of differential liquid or gas pressures under all normal industrial conditions are now available from ARIC Ltd.

NEW ARIC PRESSURE GAUGES

For the higher static pressure ranges, 6" gauges are used utilising two Bourdon tube pressure elements acting in opposition through a differential rack and pinion mechanism, to operate a balanced pointer. This range extends from 0-3.5 lbs./in.² to 0-1,200 lbs./in.². For the lower static pressure instruments the Bourdon tubes are replaced by a pair of brass bellows. Both types of system are mounted on rigid base plates.

This range also includes 4" gauges for a maximum static pressure of 15 lbs./in.² on both inputs. These smaller gauges make use of a diaphragm capsule mounted on a specially constructed steel cradle, which also carries the gauge movements. Irish office: ARIC (Ireland) Ltd.

* * *

TO MEET the increasing demand for combined electric light and air diffusers RCM (Air

COMBINES LIGHT, AIR DIFFUSER

Distribution) Ltd. have introduced their Varivent with light fitting. This unites the well-known Varivent adjustable air diffuser with an integral tungsten lamp. The result is not only pleasing in appearance but functional.

The Varivent outer cone, light housing and bezel, are in aluminium, while the light diffuser is of sand blasted obscured glass and the lamp suspension brackets are made of mild steel.

The iris blades are manufactured in laminated plastic with brass hinge and fitting pins, the whole being housed



This is RCM Varivent air diffuser with light fitting.

in cadmium-plated mild steel enclosure. Standard finish is in stove enamel white.

More detailed information regarding the RCM Varivent can be obtained

from RCM Publication No. 209, which should be read in conjunction with RCM Publication No. 216—RCM Varivent Diffuser with light fitting. (Irish agent: Heatovent Supply Co.).

IT PAYS TO KNOW WHAT'S IN A TANK

The best High Divers rely on Normond tank content gauges. Others have run into trouble. The best Heating Engineers also refuse unnecessary risks and specify Normond for all oil-fired installations.

Send for serious technical literature and prices

NORMOND INSTRUMENTS LTD
HYDREX WORKS, PARADISE ROAD, RICHMOND, SURREY, Telephone: RICHmond 1128



1965

Directory of Manufacturers, Agents, Representatives and Distributors

- Readers are requested to notify this office of any additions, alterations or amendments for entries in the 1965 Directory.
- A limited number of copies of this year's edition are available on request for checking.
- Address correspondence to: "Irish Plumbing & Heating Engineer", 13/15 Dame Street, Dublin, 2.

in brief...

HENDRON Brothers (Machinery) Ltd., Little Denmark Street, Dublin, are inviting applications for literature and details of the Columbia Oiled Fired Heating Unit—completely packaged with 20 years manufacturers'

guarantee; Columbia Tubeless Packaged Steam Boilers, automatic, sizes 5 HP—25 HP; Powermaster Steam and Hot Water Packaged Boilers which are available in all sizes from 30 HP to 600 HP and pressures up to 250 p.s.i.

* * *

FENTON Byrn & Company Limited have recently announced that there

has been a price reduction in the list prices of their whole range of propeller pans. This reduction is made possible by the greatly increased volume of business which has enabled the Company to adopt advanced production techniques without in any way impairing the widely recognised quality of their products. Irish agents: Wm. Finucane & Co.

TRIANCO boiler installation at the Tregenna Castle Hotel

TWO WAY SAVINGS EFFECTED

By replacing the four sectional Cast Iron Coal Fired Boilers with the three Trianco 1 million B.t.u. Oil Fired Boilers, considerable savings in running costs and maintenance have been made at the Tregenna Castle. The new installation is automatically controlled and proving exceptionally efficient and economic. Trianco Boilers also saved physically on space in the Hotel enabling British Transport Hotels Limited to profitably increase their accommodation.

The installation was designed by the Chief Works Officer's Dept., of British Transport Hotels Ltd., and installed by G. N. Haden & Sons Ltd. of Torquay. The boilers operate on 35 sec gas oil. Trianco Boilers: Oil Fired from 75,000 B.t.u. to 2 million B.t.u. and Solid Fuel from 55,000 B.t.u. to 2 million B.t.u.

TRIANCO
automatic boilers

BARBOUR INDEX NO. 91



Write for brochures to:

TRIANCO LTD. Dept. No. XXX, IMBER COURT, EAST MOLESEY, SURREY. EMBERBROOK 3300 (8 lines)

HEATOVENT SUPPLY COMPANY, 5 Upper Fitzwilliam Street, Dublin, 2. Phone 63061.

Stockists and Distributors:

Messrs. Thomas Helton & Co. Ltd., 18 Westmoreland St., Dublin 2, and Messrs. Baxendale & Co. Ltd., Capel St., P.O. Box 56, Dublin.

Twenty-nine

The Irish Plumbing and Heating Engineer.

THE KINNIS & Brown Group of Bromley have now developed a range of seven Aqua-Clear Feedettes for automatically protecting small capacity water-carrying equipment from scale and corrosion. The range covers water capacities varying between a mere drip or trickle up to 200, 300 and 400 gallons an hour.

SCALE AND CORROSION PREVENTION

These new Feedettes are ideal for low-cost scale and corrosion prevention, in equipment such as small refrigeration units and boilers.

Each is a toughened Perspex cylinder half-filled with Aqua-Clear inhibitor crystals. The Feedette is plumbed direct into existing pipework and the water flows through it to carry a harmless solution of the crystals throughout the system. The Aqua-Clear solution forms a microscopically thin, protective film on all metal surfaces in contact with water and also holds the mineral salts, which normally cause scale build up, in suspension or solution.

* * *

THE latest addition to the range of



equipment for heating, ventilating and

NEW ROLL TYPE AUTO AIR FILTER

The filter is a horizontal roll-type unit with an extended filtering surface, enabling over 50 per cent. more air volume to be handled than conventional roll type filters.

Simplicity and compact design enables the unit to be offered at a low capital cost and also effect substantial saving in the size and cost duct connections.

The new filtering medium gives efficiency of 96 per cent. and a dust holding capacity of 130 grams/sq. ft. (tested in accordance with BS.2831) when handling air at a velocity of 500 ft. min. through the filter medium.

Keith Blackman also manufacture

air conditioning manufactured by Keith Blackman Ltd., is the Conomat-X auto-

self-contained T Type Dust Collecting units for individual application to general grinding and polishing machines, Series TF Filter Dust Collectors catering for the larger dust collecting plant; Automatic self-cleaning filters, high efficiency cyclones collecting dust particles down to 5 microns, Hydro Precipitation and fans with paddle type impellers for handling materials.

in brief . . .

CORRIE, MacColl & Son, Ltd., have moved to their new address at 761, Henley Road, Trading Estate, Slough, Bucks. Telephone: Slough 27436. As the company now supply oil and gas burners, the Division has been re-designated Elco Burner Division.

* * *

FOLLOWING the current trend for lightness with rigidity, RCM (Air Distribution) Limited have recently announced that their Fixed Blade Louvres are now standard in extruded aluminium. In addition, the range has been extended to include the new narrow and wide sharpline models. RCM Publication No. 203 describes in full the functions, full technical data, etc., of the Fixed Blade Louvres.

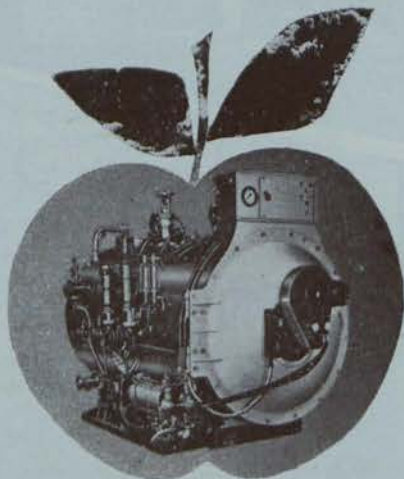

A BOILER A DAY . . . leaves John Thompson Glasgow Works for installation somewhere in the British Isles. There are more Thompson package boilers currently being commissioned than any other type or make. These are the facts behind Britain's most successful range of oil-fired package boilers—the best-selling 'Multipac' and 'Demipac' Ever since their arrival on the steam raising scene, these fully-automatic oil-fired units have consistently proved first choice for many thousands of consulting, heating and maintenance engineers. The 'Demipac'—supplying from 500 to 3,500 lb/hr of steam—is designed for the manufacturer who wants a relatively small amount of steampower but who still requires the benefits of completely automatic control. Ideal for garages, greenhouses, laundries, hotels and all types of small process and heating duties. For complete facts and figures of the highly successful 'Demipac' Package Boiler, write JOHN THOMPSON PACKAGE BOILER DIVISION, LILYBANK WORKS, LONDON ROAD, GLASGOW, E.1.



NEW ARIC TANK CONTENTS GAUGE WITH REMOTE READING UP TO 100 FT.

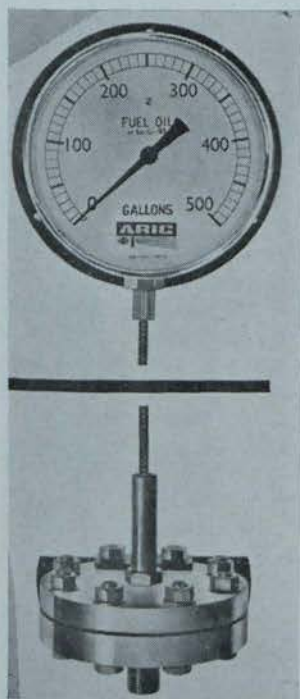

ARIC TRANSMITTING PRESSURE GAUGE WITH STAINLESS STEEL DETACHABLE DIAPHRAGM



★ **YOU HAVE INSTRUMENTATION PROBLEMS OR REQUIREMENTS?**

Our wide range of ARIC Instruments cover all types of measurement and control of pressure and temperature.

★ **YOU HAVE INSTRUMENTS FOR REPAIR ?**

Why not call in ARIC and make use of our wide repair facilities here in Dublin.

★ **YOU HAVE INSTRUMENTS ON SITE THAT REQUIRE MAINTENANCE ?**

Our highly skilled outside maintenance unit can repair on site.

ARIC (IRELAND) LTD., 6 MONTAGUE STREET, DUBLIN 2. TEL.: 53821/55510

ISOPAD ELECTRIC SURFACE HEATING

For raising and maintaining elevated temperatures, Isopad products offer distinct advantages. Electric surface heating is clean, economical and gives exact temperature control over large or small areas, evenly, or in gradients.

Isopad products can be used for metal or glass pipes, tanks and vessels of any shape or size. Where flame-proof operation is necessary, the special Isopad design is accepted by the authorities. Installation is simple and costs little.

Isopad standard products are made for all purposes within the range—100°C. to 800°C. and m.f. induction heating is available when required. We are also able to offer individual advice and working plans right through to controls and installation, from basic details of your requirements. Please write for comprehensive catalogues.

ONE OF MANY FORMS

Tanks storing edible fat at 110°F heated by Isopads giving 4kW per tank. Farna Cream Products Ltd. London.



**ISOPAD LIMITED · BOREHAM WOOD · HERTS · Telephone: ELStree 2817 (6 lines)
Midlands: Tel: Hanbury 415 N. England: Tel: Horsforth 2511 Lancashire and Cheshire:
Tel: Ringway 6467 Scotland: Tel: Glasgow City 4704 Eire and N. Ireland: Tel: Belfast
612141 S.W. England: Weston-Super-Mare 2945 S.E. England and London: Head Office**

trade Topics

A SPECIAL version of the unique Leonard 72 dual-control, thermostatic mixing valve has

SPRAY UNIT FOR HYGIENIC HAND WASH

been developed for use in surgeons' scrubbups, clinics, medical units and similar locations where non-contamination of the hands after washing is essential. Though offering many advantages over similar units previously made by the same manufacturer, the new product is less costly.

The principle of operation is that hot and cold water is blended to an outlet temperature which is preset by the user then thermostatically maintained by the valve and delivered to a spray rose on the outlet pipe. Control of the flow is also built-in and, though the flow may be started in the ordinary way by turning the control with the hands, an easy wrist or elbow movement will close the tap after washing, so that there is no re-contamination of the hands from the control.

Though the new product has been designed primarily for use in hospitals and other medical establishments, the manufacturers, Walker Crossweller & Co. Ltd., of Cheltenham, expect that it will also be widely used in many industries, such as food and pharmaceutical, where high standards of hygiene must be maintained. Irish agents: Modern Plant Ltd.

Please remember those subs

DURING the next few weeks I.P.H.E. readers will be getting their annual Subscription renewal reminders. Please assist our circulation department by returning the Renewal Form as quickly as possible.

Natural gas from Europe ?

IRELAND is one of the countries mentioned in plans to pipe natural gas from Holland to outlets on the continent and these islands. The gas has been found in northern Holland by a subsidiary of the Ambassador Oil Company.

An American company, now bringing the gas to Dutch cities by pipeline, plans to extend the system into Britain and then across the Channel into this country.

Other European countries may be supplied from the same huge pocket, which geologists have traced far out into the North Sea.

Irishmen are helping to lay the pipelines that already are bringing the gas—it is more potent and somewhat cheaper than the manufactured product—to major Dutch cities.

The project of bringing the gas to cities and towns involves the laying of huge pipelines from the source of the supply. This type of work has been carried out in America by Morrison-Knudsen, and they expect that the experience gained in laying the lines beneath Holland's many canals will be invaluable when they begin cross-channel operations.



Going up !

ABOVE—The hunt is on and here one of the seismic survey ships is seen operating in the North Sea for the Gas Council-Amoco Group. Shock waves from this dynamite explosion reveal the pattern of the underlying strata. AT LEFT—A view of the buoyant cable on a seismic survey vessel.

FIGHTING THAT OLD ENEMY OF DAMPNESS

SO striking have been the results of Rentokil Laboratories' Electro Osmotic process for curing rising damp in walls that in future all electro osmotic circuits installed by Rentokil will be covered by a free 20-year guarantee. "We are the only firm of standing to offer a guarantee for such a period," says Rentokil.

The Electro Osmotic process was introduced by Rentokil in 1962. The system is based on the scientific fact that damp walls are electrically charged with respect to the ground on which they stand, and as the dampness on the wall evaporates, further damp rises through the capillary movement of the moisture from the ground.

The Rentokil Electro Osmotic process is usually applied externally and

to describe it briefly, it consists of a special copper strip embedded horizontally in the walls at just below floor level. The strip, which is continuous, is earthed deeply at selected points by means of copper covered rods power driven to depths of 12 feet and over. This has the effect of discharging the electricity from the wall, preventing further damp from rising, robbing the moisture of its means of movement.

Speedy

Installation is speedy and causes a minimum of disturbance to the building, its surroundings and its occupants. Trained Rentokil operators drill up to 1" diameter holes at calculated intervals horizontally along the walls; these are linked, where brickwork is

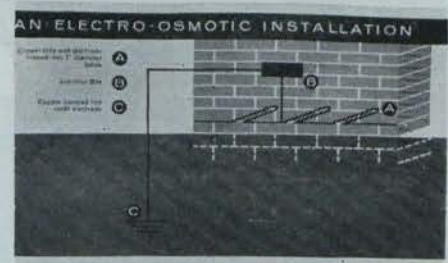

How it's done

This illustration shows how the Electro-Osmotic installation is carried out. A—Copper strip wall electrodes looped onto 1-inch diameter holes. B—Junction box. C—Copper covered rod electrode.

concerned, by channelling along the mortar joints of the bricks.

The continuous copper strip is then looped and mortar bedded into the holes, and fitted into the channels, which are then repointed with mortar. Special junction boxes are fitted at selected intervals adjoining the copper covered steel rods driven into the earth. These are then connected up and drying begins immediately. Walls of all types of material and of any thickness can be effectively treated. A free survey of properties without obligation is available.

YOUNGER PLUMBERS COMPETITION

*Sponsored by Valor Lawley Ltd. in association with the
Plumbing Trade Journal and Heating Review and the Institute of Plumbing*

FIRST PRIZE: £100

SECOND PRIZE: £50 · THIRD PRIZE: £25

and five consolation awards of 5-guinea book tokens for papers not exceeding 3,000 words on the theme,

"THE FUTURE OF PLASTICS IN THE PLUMBING TRADE"

Entrants must be plumbers or plumbers' apprentices or associated with the plumbing trades and under the age of 35 on the closing date March 31st 1965

THE JUDGES WILL BE:

Michael J. Montague, *Managing Director, The Valor Company Ltd.*
J. W. Gaunt, *Joint Managing Director, Valor Lawley Ltd.*
H. Ryland, *FIOP, ALPHE, MRPA, Editor, Plumbing Trade Journal and Heating Review*
Reginald V. Cooper, *MBE, CGIA, FIOP, MIPHE, MRSH, MRPA,*
Secretary of the Institute of Plumbing
John A. Howie, *BSc (Hons), MIWM, FPI, M Inst R.*
Chairman, Thermo-Plastics Pipes and Fittings Group, British Plastics Federation

Entry forms and full details from the Competition Secretary: Norman J. Hart, 196 Shaftsbury Avenue, London WC2

Reporting

ALL YOU WANT TO KNOW....

ABOUT IMBEDDED ELECTRICAL FLOOR WARMING SYSTEMS

THE installation of directly imbedded electrical floor warming systems raises many points which need answering from time to time. We publish here a review of the general recommendations of the cross-channel Electrical Floor Warming Association on this subject.

This article (under four main headings) covers all the questions likely to arise with this type of installation and many readers will want to keep it for reference purposes.

1. STRUCTURAL FACTORS

Co-operation between the trades.—In the course of installation an electric floor warming system becomes an integral part of the building structure, thus making demands upon both the building and electrical contractors. It is highly important, therefore, that there should be close liaison between the two trades at all stages of the work.

Perimeter insulation.—For maximum efficiency of the heating system it is most desirable to insulate the floor slab. Expanded polystyrene, cork, expanded rubber, or rigid fibreglass are good materials for this perimeter (or "edge") insulation. In ground floors this should extend vertically from screed level to the underside of the floor slab, and horizontally for 3 feet under the slab.

Alternatively, if the amount of material required is less, the vertical layer of insulation can be extended down to the footings. In considering other insulating materials preference should be given to those for which all practical purposes are non-hygoscopic.

(1). Check the site conditions.—In the case of sites known to be in an area with a high water table, a damp-proof membrane, as well as thermal insulation should be incorporated in the floor construction. This would then comprise floor finish, screed, floor slab, insulation, damp-proof membrane, blinding and hardcore.

Where definite information on site conditions cannot be obtained, it is always wise to incorporate a damp-proof membrane.

(2). The effect of fitted carpets.—Where it is known that there are to be fitted carpets and underfelts, it is advisable always to extend the horizontal portion of edge insulation under the whole of the ground floor slab. In the case of carpeted suspended floors thermal insulation can be applied to the soffit of the floors, special attention being given in this respect to the top floor in multi-storey buildings.

Fixtures and fittings on a heated floor.—It is recommended that heating cables should not be laid under floor standing fittings and fixtures unless there is a minimum clearance of 3 inches between the floor finish and the underside of the fitting.

Know the system.—Before commencing any installation work it is essential that the electrician be thoroughly familiar with the type of cable and the installation method. Where it is to be made to a drawing or schedule a check should be made on site of the cable lengths and areas involved, since any late amendments to the building plan can cause a considerable amount of trouble if not discovered before work is commenced.

Installation notes supplied by the manufacturer should be studied and adhered to, and should the electrician have any doubt as to the correct procedure the advice of the manufacturer or designer should be sought.

2. INSTALLING A CABLE SYSTEM

Procedure.—The first step consists in placing the spacer bars or fixing discs at the extremities of the cable run. The design of spacer or fixing recommended by the manufacturer should be used and the makeshift use of nails or spigots leading to sharp bends in the cable is deprecated.

The cable is then laid between the spacers with sufficient tension to maintain spacing throughout the run but capable intermediately of taking up the configuration of the floor slab under the weight of screed. Care must be taken to avoid tensioning the joints made between the heating cable and the cold tails.

Keep to cable lengths.—Heating cables must not be shortened without

reference to the designer or manufacturer of the system.

Cables laid direct on a damp-proof membrane.—Where a decision to use floor warming has been made after the floor slab has been laid, a damp-proof membrane can be applied between the floor slab and screed. Although there are certain materials which are claimed to withstand the considerable amount of heat from the cables without adverse effect, the advice of the cable and membrane manufacturers should be sought.

Acoustic and thermal insulation.—A compressible fibre quilt material is often used for acoustic purposes only. Where acoustic and thermal properties are to be combined in one material, this is more usually a rigid insulation board. Plastic or rubber insulated heating cables must never be laid in direct contact with insulation of either kind, but should be separated from it by a layer of screed.

The edges of flexible quilting must not be doubled back over the cables at the sides of the room. Any chicken wire, expanded metal or other form of screed reinforcement must not touch the cables.

Continuous monitoring.—Experience has shown that periodic testing of the heating cables up to the stage where screeding has been completed does not overcome the possibility of the installation containing a faulty cable. Suitable monitors are available by which a continuous check can be carried out. Where metal sheathed mineral insulated cables are being used, a megger insulation resistance tester used frequently during installation is sufficient.

Prepared to repair.—It is advisable to have a cable repair kit available on site when cables are being installed.

Installing a grid system.—The grid system employing bare heating elements operates at low voltage. Despite the relative robustness of such a system in employing insulated heating elements due care is needed at each installation stage.

3. APPLYING THE FLOOR SCREED

The right screed.—The screed should

be as dry as possible, free from sharp edged aggregate and well compacted to avoid air spaces round the cables. Generally a screed mix of 1:3 cement to sand is suitable but the architect or building contractors should be consulted. Lightweight or cellular screeds should not be used.

Placing the screed.—The sequence of operations should be such that screeding takes place immediately after laying, but if for any reason this cannot be done, effective steps should be taken to ensure that the cables or grids are left undisturbed and protected against any possible damage being caused by building operations carried out in the vicinity. Failures have occurred due to damage from heavy or sharp objects or other forms of maltreatment, and therefore the question of protection at this stage cannot be too highly stressed.

Precautions during screeding.—Precautions should be taken against disturbing the position and spacing by spreading the screed in a direction parallel to the runs. Operatives should wear rubber soled boots, and avoid damaging the elements with screed spreading tools. Wheel-barrow runways should be provided and the screed tipped on either side of the runway at intervals to keep the cables at the correct spacing.

4. WHEN THE INSTALLATION IS COMPLETE

Drying out the screed.—The drying out of the floor screed should not proceed too quickly. Failure to observe this simple rule may cause high shrinkage stresses and cracking. After placing keep the screed damp for, say, 7-10 days, after which it should be allowed to dry out naturally for 4-6 weeks. The floor warming may then initially be switched on but at a reduced rate to drive off the residual moisture. Electrical drying should commence with an intake of not more than three hours and progressive lengthening of intake should be by one hour per day until the floor screed is completely dry.

An impervious barrier (such as many binding mastics for use with a wide range of surface treatments) must not be applied until the screed is quite dry, i.e., after the electrical drying period has elapsed.

E.S.B. RECOMMENDATIONS.

1. Electricity Supply Board's recommendations are for complete over-site insulation using a minimum of 1" aeroboard 15 in the case of domestic installations, and 24" deep perimeter insulation using 2" thick onazote for non domestic installations.
2. Where the recommended aeroboard 15 is used, a D.P.C. membrane must be fitted. The recommended product is Isquene 1004 (an I.C.I. product).



Propane Torches

CRAFTSMEN KNOW THEY CAN RELY ON SIEVERT

...a burner for every job!

- LEAD WELDING
- PLASTIC WELDING
- PIPE BENDING
- BRAZING
- SOFT SOLDERING
- PAINT STRIPPING

9 burners plus 8 supports

Sievert propane gas burners ignite immediately and burn with an intense clean flame adaptable to all requirements from a small pencil flame to a powerful voluminous flame. Plumbers, Builders and Painters everywhere readily appreciate the advantages of the range of Sievert appliances.

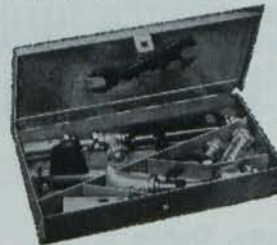

HANDYMAN SET 3790

These sets of equipment are packed in a well-made, strong and attractively finished carrying case containing a range of equipment which enables most jobs to be undertaken.

SEE YOUR CALOR



GAS DEALER

Use Sievert apparatus with Calor Gas Mk. 10 or larger size Gas Containers—for especially portable outfits use the small CALOR/SIEVERT Containers, both available from your local Calor Gas Dealer.



See the complete range of appliances at your local Calor Gas Dealer or for further information and literature write to:—

CALOR GAS IRELAND LIMITED
Bannow Rd., Cabra West, Dublin, 7. Telephone Dublin 47783.

KEEP PACE WITH DEVELOPMENTS—SIEVERT SHOW THE WAY

BURNER NEEDS NO COMPRESSED AIR SUPPLY

THE Swiss Prodonta MMG bunsen burner and welding torch does not require a compressed air supply, the nozzle being designed in such a way that eddy-currents are generated at the outlet. This action causes the correct mixture to be made between gas and air, making the burner foolproof and dispensing with the need for air adjustment.

The resulting pencil flame is said to have a high force and temperature (up to 1,912°F can be reached) and can be adjusted in height from ½ in. to 8 in. with a simple external screw cap.

A pilot light is also a feature of the Prodonta MMG. The actual burner fits loosely into a cast iron base and can easily be removed when it is to be used as a welding torch. From Halpin & Hayward Ltd., 16/17 Lower O'Connell St., Dublin.

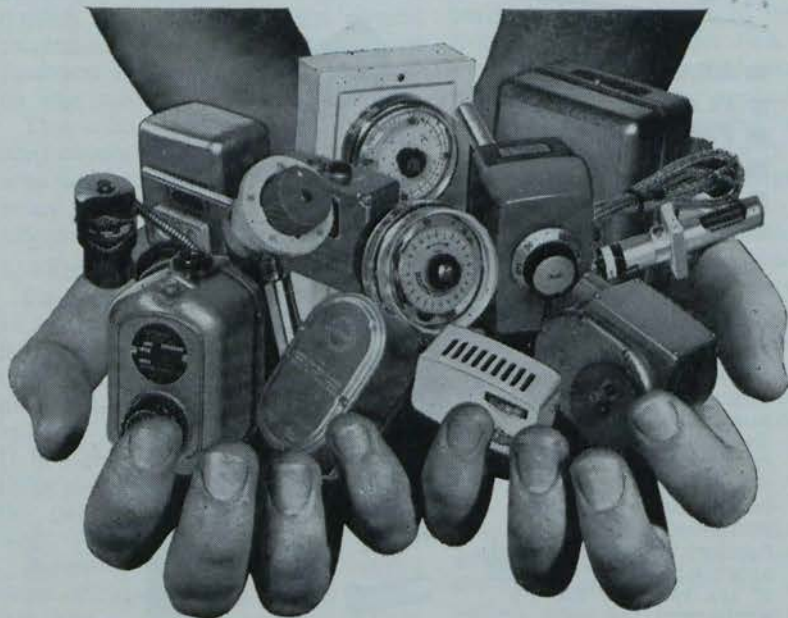

NOW! OBC SERVICE BETTER THAN EVER AT THE NEW DUBLIN DEPOT



379/381 South Circular Road,

Rialto, Dublin 8.

Tel.: DUBLIN 53026/7/8/9

O.B.C., the largest stockists and suppliers of all forms of domestic and industrial Heating Equipment, can now be of even better service to Heating Engineers and Plumbers.

- New, larger depot with all equipment centralised under one roof.
- Vast stocks of equipment, including: Radiators, Accelerators, Mixing Valves, Radiator Valves, Oil Burner Controls, Domestic Heating Controls, Fire Valves, Pressure Gauges, Level Alarms, Nozzles, etc.
- Fleet of delivery vehicles ensuring rapid, on-site deliveries all over the country.
- Free technical advice.

Send to New Address NOW for free copy of O.B.C. Catalogue

BRANCHES AT: DROITWICH (Head Office) • LONDON • GLASGOW • BELFAST
CARDIFF • NEWCASTLE • LEEDS • BRISTOL • BOURNEMOUTH
MANCHESTER • NOTTINGHAM

INDEX TO ADVERTISERS

Airnesco Products Ltd.	15
Allied Ironfounders Ltd.	14
A.R.I.C. (Ireland) Ltd.	31
Asbestos Cement Ltd.	3
British Steam Specialties Ltd., The	Cover (i)
B.S.A. Harford Pumps Ltd.	7-9
Chatwin, Thos., & Co. Ltd.	Cover (iii)
Clyde Fuel Systems Ltd.	16
Du Bois Co. Ltd., The	Cover (iii)
Fibreglass Ltd.	18
Fisher & Ludlow Ltd.	2
Fordham Pressings Ltd.	Cover (ii)
General Electric Co. of Ireland Ltd. ..	40
Girdlestone Pumps Ltd.	26
Golden Vale Food Products Ltd.	23
Hendron Bros. (Machinery) Ltd.	25
Hilmor Limited	38
International Boilers & Radiators Ltd. ..	5
Isopad Limited	31
Leinster Engineering Co. Ltd., The	23
McMullans Kosangas Ltd.	37
Meyer, Wm. A., Ltd.	35
Mono Pumps Ltd.	1
Monsell, Mitchell & Co. Ltd.	11
Morley, G. F., Ltd.	1
Normond Instruments	28
O.B.C. Limited	36
Oil Fired Homes (I.) Ltd.	43
Perry Heating Appliances Ltd. ..	Cover (iv)
Quadrant Engineers	21
Rennert & Co., GmbH	1
Sanbra Fyffe Limited	40
Saunders Valve Co. Ltd.	27
Shires & Co. (Ireland) Ltd.	12
Small, Sons & Co. Ltd.	27
Sperryn & Co. Ltd.	8
Thompson, John (Wilson Boilers) Limited	30
Trianco Limited	29
Trox Bros. Ltd.	17
Valor Limited	33
Walker Crowweller & Co. Ltd.	4
Wilson, Henry, & Co. Ltd.	13
Worthington-Simpson Ltd.	16
20th Century Electronics (Ireland) Limited	42

INDEX TO ADVERTISERS

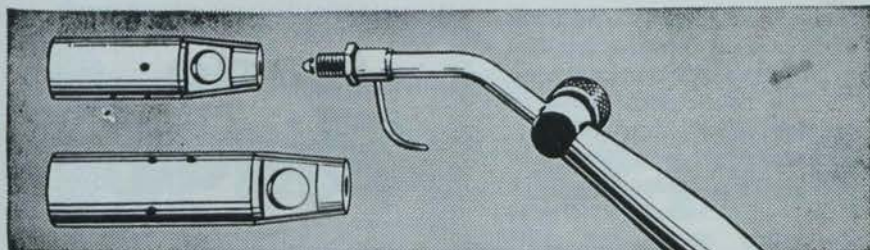

(TH3) (TH4) Kosangas High Pressure Blow Torch. Wooden handle. Needle control valve, for gas adjustment. Supplied with large or medium burner heads.

Kosangas Blow Torches

for every plumbing job!

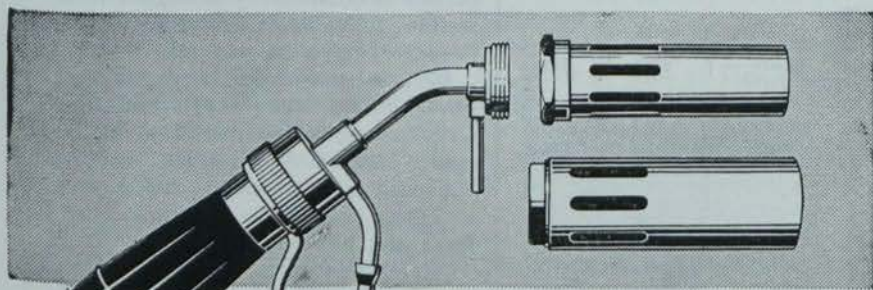

Bullfinch Mark II Blow Torch. New, patented, trigger valve, leak-proof, never needs adjustment. Micrometer bye-pass, saves £££'s on gas. Complete range of burners.

Make full use of the wide range of Kosangas blow torches, available for plumbing work. They're much more efficient than the conventional type.

The Kosangas TH3 and TH4 are designed for paint burning, pre-heating and soldering. The Bullfinch Mark 2 has a wide variety of heads, including soldering attachment. In conjunction with the small portable Kosangas cylinder, use Kosangas blow-torches for:

- PAINT BURNING · PRE-HEATING
- SOLDERING · ROOF FELTING
- JOINTING OF PLASTIC PIPES
- ANY OTHER HEATING NEEDS

The Kosangas plumber's portable furnace, with wind protected burner, is excellent for outdoor plumbing and cable work, requiring liquid asphalt, pitch, zinc, lead, tin and other fusible materials.

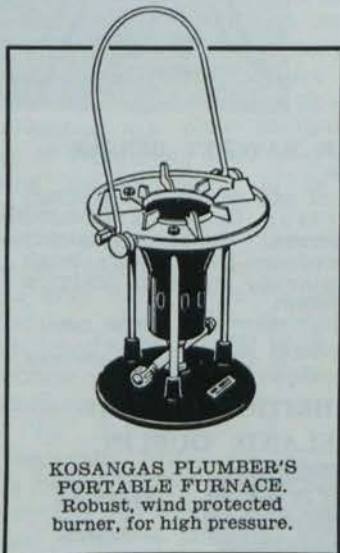

KOSANGAS PLUMBER'S PORTABLE FURNACE. Robust, wind protected burner, for high pressure.

Send for fully descriptive lists and leaflets to:
McMullans Kosangas Ltd., 1, Upper O'Connell St., Dublin. Tel. Dublin 40761-4.

ATTENTION NORTHERN IRELAND

WE are pleased to advise that, commencing with our issue for January, 1965, this journal will be divided into three separate sections, including a centre supplement on tinted paper which will be devoted entirely to Domestic and Industrial Heating, Plumbing, Ventilating and Air Conditioning in Northern Ireland. This new, extended section will include a greatly enlarged Northern "Trade Topics" coverage and specially commissioned technical articles by leading trade personalities in the area. As a further extension our August issue will be published as a special Northern Ireland Special Edition.

This development follows representations from trade interests who are anxious that the journal should provide a wider coverage in keeping with the extensive nature of the industry in Northern Ireland, and it represents another stage in the editorial development of the I.P.H.E.

RECENTLY appointed agent in the Republic for Bentone Oil Burners of Sweden is Mr.

AGENT FOR BENTONE APPOINTED Robert J. Burke of 4 Molesworth Street, Dublin.

Bentone burners work on the injector principle, offering big fuel savings and are being produced at an ever increasing rate to meet a growing demand—annual sales are now in the region of 55,000 burners a year.

Next month we will review this important range which offers burners for both heavy and light fuel oil with different models of each main type. Mr. Burke is also agent for: Mercury Thermometers, Recorders, Pressure and Vacuum Gauges by Helmut Schlegel K. G., Germany; Rexotherm Bimetal Thermometers, Pyrometers, Altitude Gauges, Combined Instruments by Rexor Industri A.B., Sweden, and also Time Switches and Combustion Control equipment, Theodilites, Levels, etc.

in brief...

THE E.S.B. has warned the public through advertisements in the national press that they are "aware that misleading claims regarding running costs are being made by canvassers for some types of electric heating installations."

Householders have been advised to "check carefully such claims with the E.S.B. before committing themselves to a contract for the installation of equipment."

THE Lead Development Association has just issued a booklet entitled "LDA Services Publications and Films." The publications—most of which are available free of charge—cover all main uses of lead, and range from comprehensive reports on conferences and technical meetings to SFB information sheets and notes specially produced for students.

* * *

ASCOT Gas Water Heaters Limited have just issued three further technical information sheets on their appliances. This follows the introduction earlier this year of a new style of folder for trade and technical distribution. The appliances covered

trade Topics

in the three new folders are the 525 range, the 710 range, and the 810 range.

* * *

THE London office address of Midland Industries Ltd. has been changed to 33, Catherine Place, London, S.W.1.

* * *
* * *

RECOGNISING that space in the modern kitchen is often at a premium, Redfyre Limited have designed their new 65,000 B.t.u./hr. gas-fired boiler to fit into the same size cabinet as the Autogas 45. The extra output is obtained by adding a third section to the boiler body, giving two flueways above the gas jets.

In construction this new boiler is similar to the Autogas 45. Both flueways are ribbed so that they can be easily brushed down from the top and each is fitted with a baffle plate to reflect heat on to the transfer surfaces and increase efficiency.

As a small bore unit the Redfyre Autogas 65 comes with its own electric time clock and an Opiomatic variable head circulating pump. It incorporates the Adatrol gas control, electric glow coil ignition to light the pilot flame and two switches to set the running conditions. Once the pilot is alight the boiler runs automatically under the control of the thermostat according to the conditions set.

The cabinet is finished in white stove enamel with an anodised aluminium fascia trim around the thermostat knob in the right hand panel. It stands 36" high, is 18" wide, and the boiler has a total depth of 28 $\frac{1}{2}$ ".

Each month The Irish Plumbing and Heating Engineer will contain a comprehensive survey of the month's trade news under the "Trade Topics" heading.

We invite contributions to this column by way of news of new product introductions, of product promotions, of developments within your organisations and of appointments, to list a few.

PORTABLE TUBE BENDERS



LIGHTWEIGHT BENDING TOOLS
Types GL.O and GL. Minor

Compact machines to produce good quality sets, compound bends, etc., in non-ferrous tube. Robustly built, they can be carried in tool bag and are particularly suitable for small bore heating and similar types of installation.

CAPACITY: GL. O — $\frac{1}{4}$ ", $\frac{3}{8}$ " and $\frac{1}{2}$ " dia. copper tube.
GL. Minor — $\frac{1}{4}$ " and $\frac{3}{8}$ " dia. copper tube.

FOLDING STAND MODELS
Types GL. 2B and GL. 3B

The original and most efficient portable benders made for bending light gauge copper tube. Require no fixing or bolting down and produce good quality bends, cold and unfilled, to exact measurement on standard radii.

CAPACITY: GL. 2B — $\frac{1}{4}$ ", $\frac{3}{8}$ " and 1" dia. copper tube.
GL. 3B — $\frac{1}{4}$ ", $\frac{3}{8}$ ", 1", 1 $\frac{1}{2}$ " and 1 $\frac{3}{4}$ " dia. copper tube.

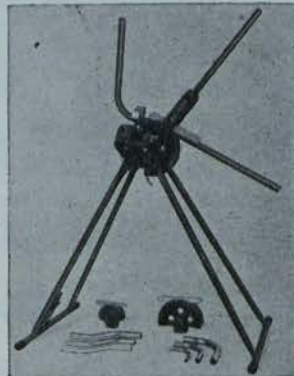

EASY-WORK RATCHET BENDER
Type RP. 5B

A machine of new design with a rotary bending action through a powerful ratchet operated screw. Completely portable, produces good quality bends speedily, accurately and with minimum of manual effort.

CAPACITY: $\frac{1}{2}$ " to 2" dia. copper tube.
 $\frac{1}{2}$ " to 1 $\frac{1}{2}$ " o.d. conduit.
 $\frac{1}{2}$ " to 1" nom. bore gas and steam.



SEE OUR PERMANENT EXHIBITION AT THE BUILDING CENTRE OF IRELAND, DUBLIN.

FIRST MADE



FINEST MADE

For details of range of hand-operated, hydraulic and motorised machines handling up to 8" dia. tube, apply to local stockist or write to:—
HILMOR LTD. (Sales and Service), CAXTON WAY, STEVENAGE, HERTS.

SPECIAL REVIEW

THIS MONTH

HOT WATER SUPPLY EQUIPMENT
AND BOILERS.

The good and the bad

HOT water at usable temperature, in copious amount, whenever needed, with an attractive installation cost and with reasonable running costs—these are the down-to-earth factors which distinguish the good systems from the poor or indifferent ones.

Examining running cost first for a change—this often gets looked into only when it's too late, that is when the user finds the installation too expensive to run.

All storage systems of D.H.W. supply will suffer "standing" heat losses. This is due to heat emission from the warmer hot stove surfaces to the cooler air in contact with them. Thus, the standing heat loss is mainly convective although radiation will account for some heat loss.

In either case the rate of heat loss will increase as the water-air temperature differential increases. Stored water at above 140°F. loses heat far more quickly than water below 140°F.

Thermal insulation of hot store vessels is essential if fuel usage is to be kept at reasonable economic level.

Maintenance is another item all too seldom considered when selecting and installing D.H.W. systems. Labour charges are high these days and systems designed with a thought to elimination of all but essential maintenance will be obviously less costly to run.

In hard water districts "fur" is a dangerous and expensive incurring bugbear. Dangerous because it can block hot water pipes, and expensive because de-scaling is a costly, not to mention messy, business.

Where hard water abounds, indirect systems are a wise rule for boiler-cylinder installations, no matter what type of boiler or fuel is used. This will eliminate all problems with regard to scale deposition in boiler and primary flow and return pipes. It will not, however, prevent "fur" deposition in the draw-off portion of the

indirect cylinder and its associated draw-off pipework.

Manlids or bolted on tops are essential if descaling of hot store vessels is to be undertaken as may be required. The pity of it is, we see so many installations of direct and indirect kinds with no access to clean the hot store at all.

Electrical immersion heaters fitted to such vessels have been known to "fur" coat to such extent that upon eventually burning out they could not be extracted without serious damage to the hot store vessel itself. Often, it has been necessary to replace the hot store as well as the burned out heater. Avoidable expense like this has been due to overheating the water by persisting with too high thermostat settings (no electrically heated hard water should be allowed to exceed 140°F.) and to the absence of ease of access for periodic internal examination of the hot store vessel; and remember, even indirect cylinders will have progressive "fur" depositions in their draw-off hot water store compartment. So don't forget to order manlids for hot store vessels used in hard water districts. They are obtainable with copper cylinders as well as galvanized m.s. ones—it's just a matter of recognising their need and ordering the hot store to be so equipped.

"Fur" is the enemy of electric and gas water heaters too. Most of the electric ones have reasonable access for descaling, which, if not done often enough, may well lead to expensive replacement of burned out elements.

Instantaneous gas water heaters suffer "fur" deposit, especially at the heat exchanger where the temperature is hottest. The exchangers are dismantlable and may be descaled by chemical means—a job best left to people used to doing it. This service can be costly but a burned out heat exchanger is more so.

Water softeners of the base exchange type will cure the "fur"

menace in hard water areas, if they, too, are properly serviced and regenerated by the householder as often as required. Scale reducers, which are not water softeners, will prevent the formation of scale build-up into hard, solid, masses.

Fuel choice will affect running cost but here one has to weigh the aesthetic advantages of the more costly heating forms against the less labour-saving ones of others. But all types of systems and fuel should be examined. Very often it may be found that electricity—the most expensive water heating medium of all—may well prove the cheapest in certain circumstances.

Copious supplies of hot water indicates the presence of enough to meet the predictable needs of the household. With boiler-cylinder systems this has usually meant a 27 or 30 gal. hot store. The time has come to question is a 30 gal. hot store really big enough? With growing public awareness of the well being associated with adequate bathing facilities in the home, more baths will be taken at more frequent intervals. Is 30 gallons enough? Remember it's too late to do much about it once the installation, and too small a hot store, is in.

Copious supply means a good out-flow of hot water at taps. This in turn means the application of simple yet effective pipe sizing methods. The performance of certain items of equipment need to be studied too. Some items, with many admirable qualities, are capable of delivering only 1½ gal. of water at 140°F./min., whereas for quick bath filling an out flow rate of 4 g.p.m. is desirable.

Appliances for heating water for domestic purposes are now made to unimpeccable standards to suit all fuels and circumstances.

Each and every one of these should be critically examined in the light of all proposed new installations.

A. L. TOWNSEND.



water heaters

1. **UNDERSINK WATER HEATER.** Easily installed under sink, with special fitment provided. Thermostatically controlled. Capacity 2 gallons. Loading 1 KW. Price £13-10-0.

2. **'HOTFLO' 2 GAL. WATER HEATER.** Easily installed. Thermostatically controlled. Glass fibre tank lining prevents heat loss. Loading 1 KW. Price £12-0-0.

3. **CISTERN TYPE STORAGE WATER HEATER** — Available from 5 gal. capacity upwards. Ball valve tank, hot water tank heating elements and thermostat are embodied in one unit. Price from £27-10-0.

4. **NON-PRESSURE TYPE WATER STORAGE HEATER.** Single outlet only. Takes its cold water supply direct from mains. Available in capacity from 2 to 20 gals. Prices from £12-0-0.

5. **PRESSURE TYPE WATER STORAGE HEATER**—for multipoint installations — takes its cold water supply from an overhead tank. The 15 or 20 gal. sizes provide ample supplies for the average household. Larger sizes are available for hospitals, schools, institutions, etc. Price from £11-19-3.

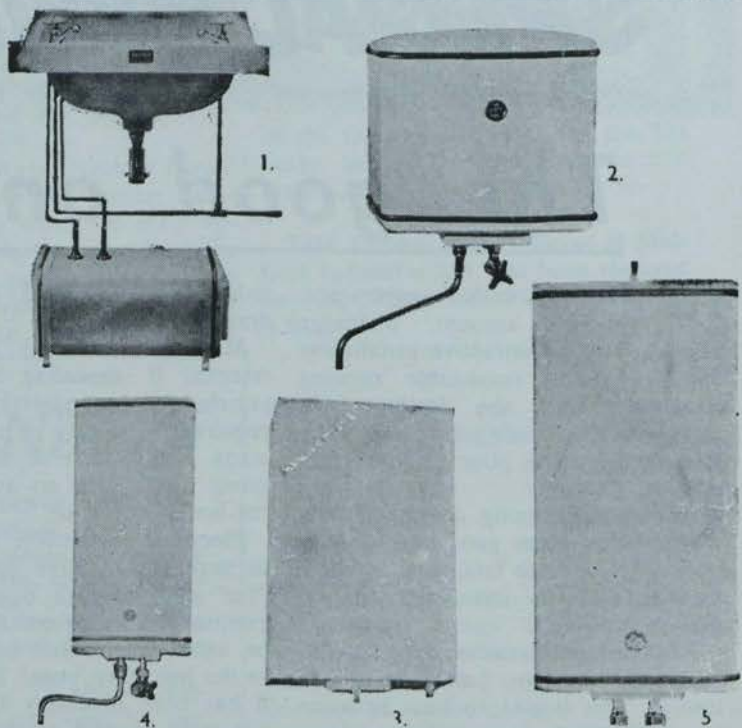

The General Electric Co. of Ireland Ltd.

Sales Departments, Trade Counter and Showrooms:
DUNLEER HOUSE, STORE ST., DUBLIN 1.

Branch Showrooms:

54 DAME STREET, DUBLIN 1.

on the site, Plumbers fit . . .

the first choice Sanbra Fyffe



'SETFLO' RADIATOR VALVE

PLUMBERS' BRASSWARE, TAPS & FITTINGS

for ALL requirements in Plumbing and Heating Services.

THE SANBRA FYFFE RANGE INCLUDES:—

- CONEX-INSTANTOR Compression Joints and Fittings for Copper Tube.
- Valves, Stopcocks and Drawn Copper Traps.
- SANBRA FYFFE Brassware — including the renowned 'Easilyne' and 'Aqualyne' Luxury Taps and Fittings — as well as Pillarcocks, Bibcocks, Wastes, Plugcocks, etc.

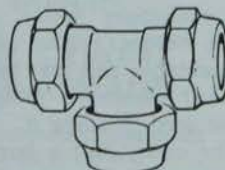

TEE-PIECE.



'Aqualyne' Highnecked Pillarcock

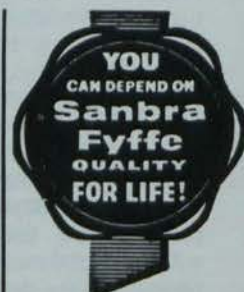

SANBRA FYFFE LTD., CONEX WORKS, SANTRY AVE., DUBLIN, 942
Telephone: Dublin 375131 (5 lines). Telegrams: Sanbra, Dublin. Telex 5325.

SANTON "Off-Peak" horizontal electric water heaters are designed to take full advantage of "Off-Peak" tariffs offered to the consumer by the electric supply industry. Two standard capacities are available: 50 gallon with 3 kw. heater, and 100 gallon with 4 kw. Both units are thermostatically controlled and higher loads can be made available at extra charges.

The 50 gallon storage unit is rectangular in construction, measuring 62" x 21" x 21", and is more or less free standing from a mounting point of view. The 100 gallon is cylindrical, dimensions 67" x 28", necessitating cradling on site. Both units have cylindrical copper interiors, thermally lagged with specially treated granulated cork within a sheet steel outer case pretreated and stove enamelled white. Larger capacities up to 2,000 gallons can be made available to special order.

The rate of recuperation is to the order of 3 gallons per 1,000 watts loading of heater per hour, i.e., 3 kw.—9 gallons (72 pints per hour); 4 kw.—12 gallons (96 pints per hour). An easily adjustable restrictor device ensures that the correct rate of flow can be selected.

Of particular interest in the Santon range is the Tallstar "Off-Peak" thermal storage water heater, which, unlike the magnetic valve controlled "Off-Peak" heaters, is a pressure type floor mounting thermal storage heater for connecting to orthodox cold water storage tank and fitted with normal vent pipe and top draw off arrangements. As an "Off-Peak" unit it is manufactured in 30 gallon (15 top, 15 bottom), 50 gallons (25 top, 25 bottom) capacities. Larger units up to 500 gallons capacity, using the "Tallstar" principle, are available. The manufacturers are Santon Ltd., Newport, who are represented here by Chas. Nolan & Co.

* * *

BASTIAN & Allen Ltd., of Harrow, Middlesex—a division of Parkinson Cowan Ltd.—manufacture a wide range of electrode hot water and steam boilers. A comprehensive range of units is available working on medium or high voltage. In the medium range units are available in ratings from 10 kw. (34,000 B.t.u./hr.)—1440 kw. (4,900,000 B.t.u./hr.), while on high voltage models are supplied with ratings from 750 kw. (2,550,000 B.t.u./hr.) up to 20,000 kw. (68,000,000 B.t.u./hr.).

**In this equipment review
we take a look at new
developments in the fields
covered by the foregoing
special review. (All claims are
those of the manufacturers).**

AN INSTANTANEOUS gas water heater specifically designed for bathroom use has been introduced by Ascot Gas Water Heaters Ltd. The model 611/4 supplies hot water to the bath and bathroom basin by means of a swivel spout. As well as the spout, the heater is fitted with an extra outlet for connection to an additional hot tap or shower.

Two gallons of hot water per minute raised 50 degrees F. from cold or one gallon per minute raised 100 degrees F. from cold can be obtained from this Ascot. The model is ideally suited for installation in properties being modernised and is particularly useful as a replacement for the old type "geyser" as it has the same size flue outlet.

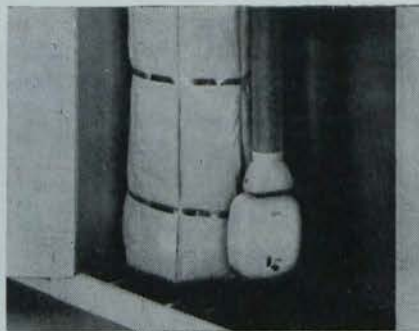

The Ascot C.T. 12 Unit.

The Ascot C.T.12 circulator is a small form of gas-fired boiler for connection to a hot water storage cylinder. It may be used with an existing hot water storage tank to supplement another water heating system, as a booster to an existing system, or as an alternative water heating during the summer.

Also of interest from the Ascot range is the Newlyn K.30 high speed sink gas water heater which replaces two previous water heaters—the Newlyn S12/2A and the Speedlyn S30, which have now been withdrawn from sale.

* * *

THE new Ideal-Rondo round firepot hot water boiler has many advanced

features and, at the very competitive price, represents outstanding value on the market to-day. It will supply all the hot water the average family needs—at a very reasonable running cost.

With a two hourly refuelling period, it has an output of 20,000 B.t.u./hr. Its B.S.S. continuous output with four hourly refuelling is 12,500 B.t.u./hr. Attractively designed to suit the modern kitchen, it has a neat white stove enamelled casing and a durable vitreous enamelled cast-iron top plate.

The ingenious rocking bar and dumping device greatly simplify riddling and ash disposal. Air for combustion is controlled by an easily operated quadrant. For easier installation the "Ideal-Rondo" is supplied fully assembled and packed in a protective carton.

* * *

THE Sadia UDB-30 electric storage water heater is designed to meet the needs of the larger households. It is 47 inches tall, holds 30 gallons and is capable of providing two baths in quick succession. The appliance is fitted with two thermostatically controlled elements. When the switch at the bottom right is up, only the upper 100 watt element is in use. This heats water for immediate use in quantities ample for washing up purposes and other routine domestic tasks.

When two baths are required within a short period, the lower heating unit of 2,000 watts loading should be switched on about two hours beforehand. The Sadia UDB-30 is finished in white stove enamel and is manufactured by Sadia Water Heaters Ltd., Sadia Works, Rowdell Road, Northolt, Middlesex. The Irish agent is A. P. Haslam. Another product from the Sadia range is their new free standing 20 gallon electric water heater (already reviewed in Trade Topics).

* * *

THE BUDERUS Logana 22 series is now available for oil or solid fuel consumption. Now both fuels may be burned at will in the new PC 22 range (illustrated). Double hinged doors allow the equipment not in use to be swung to one side. A safety switch cuts out the oil burner when the boiler is on solid fuel. The new P 22 type for oil or C 22 type for coke, as well as the PC type, are stocked in Dublin in a very large

Continued overleaf

Forty-one

NO WAITING WITH WARMEX

ECONOMIC

CENTRAL HEATING

EVEN DURING PEAK PERIODS

With Warmex there's no waiting for off-peak periods. It provides instant heat **WHEN AND WHERE YOU WANT IT**, evenly controlled by time switches and automatic controls and surpassing the economy of electric storage heaters—without their bulk. The Warmex System can be easily installed at a very moderate cost. Furthermore, Warmex radiators are guaranteed for five years.

- This unique construction is fully patented.
- Easy payment plan. Personal loans available.
- Installation takes only an average of two days without any structural alterations.
- Time clocks set to your own particular requirements.
- Pullin thermostats control your heat.
- Running costs are very economical.

Synchronous Time Switches

by

**ENGEL & GIBBS
LTD.**

Timekeeping is controlled by high quality gears made to the best Swiss standard and the time switch is enclosed to prevent interference or damage from dust or dirt.

GUARANTEE

The WARMEX system is guaranteed for five years.

Sole Concessionaires in the Republic of Ireland, to whom all enquiries should be addressed:

20th CENTURY ELECTRONICS

(Ireland) LTD.

38/39 Grafton Street, Dublin. 'Phone 70939.

PRODUCT REVIEW

from previous page

range of sizes by Quadrant Engineers, 167 Strand Road, Dublin, who also stock other Buderus boilers up to an output exceeding 1,000,000 B.t.u./hr.

* * *

THE slim-line compact design of the Main Coniston belies the capacity of this attractive new storage water heater by Main-Morley Limited, which provides two gallons of water at 140 degrees F., and will meet all normal requirements for hot water at the kitchen sink and is equally suitable for supplying the bathroom wash-basin. Reheating time is less than 20 minutes, giving a total output per hour of 7 gallons.

The Coniston incorporates all the well tried features of earlier storage water heaters, plus the added refinement of a built-in water control tap and compact re-styled casing. A model without the built-in tap is also available if required.

Also from Main-Morley is the new Semain balanced flue bath water heater which operates with high efficiency over a wide range of water pressures. It provides instantaneous hot water to the bath and handbasin, continuing to give an 80 degree F. rise in water temperature on all flows from 1 to 1½ gallons per minute.

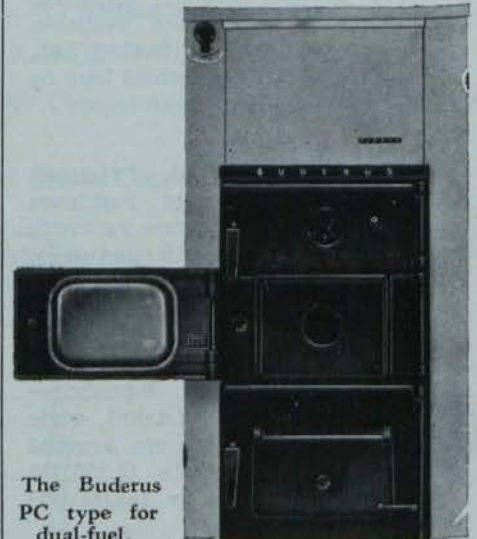

The Buderus PC type for dual-fuel.

OIL FIRED HOMES (I.) Ltd.

ANNOUNCE OFFICIAL OPENING OF REDECORATED SHOWROOMS

★ Oil Fired Homes (Ireland) Limited have been appointed sole agents for Perkins Boilers Limited of Derby. The Company is now under a newly constituted Board of Directors, with Mr. T. F. Barrett as Managing Director since 1st July, 1964. We are opening our redecorated showrooms on the 25th November, where there will be a comprehensive display of oil fired equipment, including some working models. Our principals, Perkins Boilers Limited of Derby, manufacture a very large and comprehensive range of oil fired boilers on the domestic side. They have been the first to introduce new ideas regarding the size of oil fired boilers and the flue requirements of them. Their "Mini" range of boilers was evolved by reducing the standard cross tube boilers to one-third their size and retaining the quoted output at the same time. They have introduced a flue condition on these boilers by assisting the draught with excess air fed from the fan into the chimney, which acts with a scent-spray effect. Oil Fired Homes (Ireland) Limited realise that the installing trade requires a full range of ancillary equipment to support their main range of oil fired boilers and they have available everything from the tank gauge to the chimney cowl which may be required in the installation of oil fired equipment.

★ The Perkins range of oil fired boilers recommend, solely, Shell domestic fuel oil and B.P. Domesticol.



**Perkins "Flue-less"
Wall-mounted Pressure-
Jet "Mini" Boilers**
have outputs of 50/60/80/
100 and 150,000 BTU's
per hour, and are the
most highly efficient,
fully automatic boilers
available at any price.

Sole Concessionaires for
Republic of Ireland:
**OIL FIRED
HOMES
(Ireland) LTD.**
6 HARCOURT ROAD,
DUBLIN.
Telephone 54736.



HATTERSLEY (Ormskirk) Limited report that sales of their modern central heating regulators have now soared past the one million mark and in view of this and resultant bulk production methods, they have been able to effect considerable price reductions.

Although the majority of business has been due to the Domestic Heating Market, an important factor in the success of this unique type product has been the availability in $\frac{1}{4}$ " and 1" sizes as well as the popular $\frac{1}{2}$ " size.

Full details of the new prices are now available. (Irish agents: W. H. Leech & Son).

Dividend

MONSELL, Mitchell & Co. Ltd., Dublin, has declared an interim dividend of 5 p.c. less tax, for the year ending December 31 next. This is as forecast by the Board.

The Chairman, Mr. S. O'Flaherty, in a statement to shareholders, said that the company's trading in the current year "has maintained a very satisfactory level . . ."



THIS is the 3 kW. ConStor controlled output electric storage heater, a product of the Parkinson Cowan Group. ConStor is fitted with three speed fans and is available in four models, with connected loads of 2 kW., 3 kW., 4½ kW., and 6 kW.

Leckie brothers discuss plans for Everton

THE FOUNDERS of Everton Engineering Ltd.—James and George Leckie—were in London last month to discuss plans for the expansion of the firm.

At the Ulster Office in Lower Regent Street—the windows of which were devoted to publicising the products of the company for a fortnight—Mr. James Leckie, chairman, said: “We employ 250 in an 85,000 square feet factory, and we hope to double the number in the next five years. We shall be getting another 30,000 square feet of factory space for our subsidiary, Everton Hospital Engineering Ltd.”, on a 13-acre site at Whitehouse, Newtownabbey.

The company, which recently set up a London office, is planning to set up sales centres in leading British provincial cities during the next few years.

lecture

“A REVIEW of electric process heating” was the subject of a lecture given by Mr. J. H. Sharples at a meeting of the Belfast Association of Engineers earlier last month.

Mr. Sharples, a well known authority on the subject, illustrated his talk with slides showing the various processes of electric heating methods in industry.

Mr. F. W. Cox, President of the Association, was in the chair.

meeting

MR. C. A. ROAST, head of the technical sales department of Esso, was the chief guest speaker at a meeting given by the Institute of Fuel in the Sir William Whitla Hall late last month.

Mr. Roast, of the London offices of the Esso Petroleum Co., addressed the 100 plus gathering on “Observations on chimneys and ductwork for oil-fired boilers.”

smokeless

THE National Coal Board hopes that a “vast amount” of new smokeless fuel will be on the market by the end of next year, says the chair-

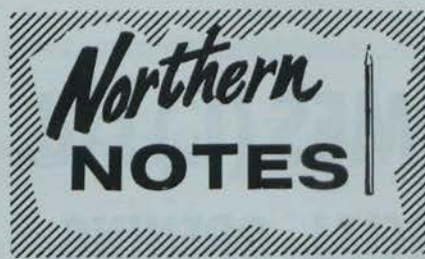

man, Lord Robens. It would be in the region of a million to a million and a half tons, he announced when opening the Board's latest housewarming centre at Brighton.

On the local scene, Mr. C. H. King, Secretary of the N.I. Coal Importers Association, welcomed the news, especially now that the Clean Air Act has been passed by Parliament.

Said Mr. King: “Any news of more new fuel is of interest. But until local authorities apply to the Ministry for the enforcement of the new Act it will mean little to us here in Northern Ireland. The Clean Air Act was passed some months ago but as far as I know there has been no great rush by anyone to establish a smokeless zone.”

insulation

THE new £5 million factory for tobacco manufacturers, Gallaher Ltd., in Belfast, was opened this month. Newalls Insulation & Chemical Co. Ltd., of 5-7 Sydenham Street, Belfast 3, undertook insulation of cold water rain pipes, tobacco driers, cold rooms and piping in laboratories. Materials used included Newalls XPS expanded polystyrene slabs, cork insulation and Newtherm Extra calcium silicate pipe sections.

gas oil

BELFAST is to be one of the first cities in Northern Ireland to switch completely from coal gas to gas oil. By 1968 the city's gas consumers will have supplies from the oil refinery at Sydenham, which is already supplying part of the gas needs of the Corporation gas undertaking.

The switch-over will cost about £1,000,000 and it is expected that the annual cost of the gas undertaking will be cut by over £220,000. The new gas will not only be non-poisonous but it will be sulphur-free, which will be of considerable value when the Clean Air Act comes into force. The change will involve abandoning the existing gas-works, which cover nearly 30 acres on the Ormeau road.

in brief . . .

● THE NEW storage heater by John Harper & Co. Ltd. drew keen interest when it was shown at a reception in Belfast's Midland Hotel last month. Smyth agencies are the Northern Ireland agents.

● Councillor T. Orr, Chairman of Belfast Corporation Gas Committee, last month presented a High Speed G. gas fire to Mrs. S. Wallace, Dunvegan St., as part of her prize for winning the Belfast Gas Home Heating Competition. She also received a Quintet room heater and a Debonair hall heater.

THE aim of all modern boiler manufacturers is to produce a boiler which gives the most efficient and most economical results with the minimum of attention from the user. The new A-40 Anthracite boiler from Powell Duffryn Heating Limited matches up to these exacting requirements and has the extra advantage that it is completely independent of outside sources of power for operating the automatic controls.

Since attention is limited to filling the hopper and removing a clinker brick on an average every other day, the demands upon the user are negligible. No regular skilled maintenance is required throughout the life of the boiler.

The Powell Duffryn A-40 Anthracite Boiler has a rated output of 40,000 B.t.u./hr. Thanks to the special snap-action damper which is part of the thermostatic control, it will work successfully (as in summer) at as little as a tenth of the rated output.

* * *

OCTOBER, 1965, will mark the advent of a major exhibition designed specifically to bring together under one roof the requirements of the plumbing and heating engineer. The International Plumbing and Central Heating Exhibition will serve the trade and public alike.

Alexandra Palace is the venue of the exhibition. Organised by Exhibitions and Presentations Ltd., the exhibition is being sponsored by Plumbing Equipment News.

**A NEW
PRODUCT**

"THE DUBOIS PLASTIC TRAP" (Regd.)

**A NEW
PRODUCT**

Provn. Pat. No. 38070/60.

1¼" and 1½" diam. x 1½" seal "S" and "P" BLACK HIGH DENSITY PLASTIC TRAPS

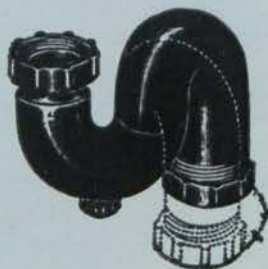

Orthodox Shape!
Smooth Bore Tubular construction.
Outlets can be turned through 220°.
A two-piece trap at a one-piece price.
Outlet on 'S' trap turned to inlet forms a through-bore bottle trap.
Frost and damage resisting.
Light weight = lower transportation costs.



Manufactured by:—

THE DU BOIS COMPANY LIMITED
15 Britannia Street, London, W.C.1

Telephone No.: TERminus 6624-5.

Telegraphic Address: "Bleitrap, London."



418 PATTERN RATCHET DIESTOCK

Better threads, easier cutting, and quick and simple die and guide changing are the attractive features of this Chatwin product. The 418 Pattern Ratchet Diestock and die must satisfy the need for a tool which makes pipe thread cutting economical. Dies are available for the standard range of B.S.P. threads and alternatively, to Whitworth, U.S. standard, and Unified, within capacity of stock.



Ample Strength for the TOUGHEST JOB



STILLSON PATTERN PIPE WRENCHES

Heat treatment of the handle and jaw gives correct degree of hardness and prevents bending and breakages. Sturdy, light in weight and easy to handle, these wrenches are guaranteed against defects in material and workmanship.

THOS. CHATWIN & CO.

Victoria Works, Great Tindal Street, Birmingham, 16

Telephone: Edgbaston 3521-3

ONE OF THE **BROCKHOUSE** COMPANIES



Meet the BIG Supermatic family...

all 18 of them

It's most useful and highly profitable to deal with such a versatile and practical family of 'Wall Flame' Oil-fired Boilers as Supermatic — the biggest, fastest-growing and most successful yet produced.

For one thing, you're able to satisfy *all* your customers, whatever their individual requirements may be—for the wide Supermatic range includes as many as 13 standard models *plus* 5 de luxe versions. Since their outputs vary from 44,000 to 300,000 BTUs, there's no problem in obtaining the *right* Supermatic boiler for the smallest or biggest heating jobs. Installers and householders don't need to make do with inferior, unsuitable or uneconomical substitutes—because you can always get them *exactly* what they want. In

addition, you can increase your profits by selling them sleek, highly efficient Supermatic Skirting Radiators—specially designed to operate best with Supermatic 'Wall-Flame' Oil-fired Boilers.

What's more, you can bank on *immediate deliveries*—thanks to our no-delay, *same-day dispatches* from huge stocks always maintained at our Eastbourne works.

It's more than likely that you will soon be ordering more Supermatic Boilers and Skirting Radiators than ever. Why? Because this year, we have more than *doubled* our publicity expenditure—to stimulate more public interest, attract many more customers to your door and boost your profits substantially.

It PAYS to ORDER Supermatic—INSTALL Supermatic—RECOMMEND Supermatic—SELL Supermatic

Fill in and post this coupon TODAY!

To Dept.
PERRY HEATING APPLIANCES LTD
Hampden Park, Eastbourne, Sussex

Please send me full particulars of your Supermatic Oil-fired Boilers and Supermatic Skirting Radiators and details of your trade terms.

Name _____

Address _____

(BLOCK LETTERS PLEASE)