


4-1-1982

## H & V News : 21st Anniversary Issue

Follow this and additional works at: <https://arrow.tudublin.ie/bsn>

 Part of the [Civil Engineering Commons](#), [Construction Engineering Commons](#), and the [Construction Engineering and Management Commons](#)

### Recommended Citation

(1982) "H & V News : 21st Anniversary Issue," *Building Services News*: Vol. 21: Iss. 4, Article 1.

doi:10.21427/D7ZX3B

Available at: <https://arrow.tudublin.ie/bsn/vol21/iss4/1>

This Article is brought to you for free and open access by the Journals at ARROW@TU Dublin. It has been accepted for inclusion in Building Services News by an authorized administrator of ARROW@TU Dublin. For more information, please contact [yvonne.desmond@tudublin.ie](mailto:yvonne.desmond@tudublin.ie), [arrow.admin@tudublin.ie](mailto:arrow.admin@tudublin.ie), [brian.widdis@tudublin.ie](mailto:brian.widdis@tudublin.ie).

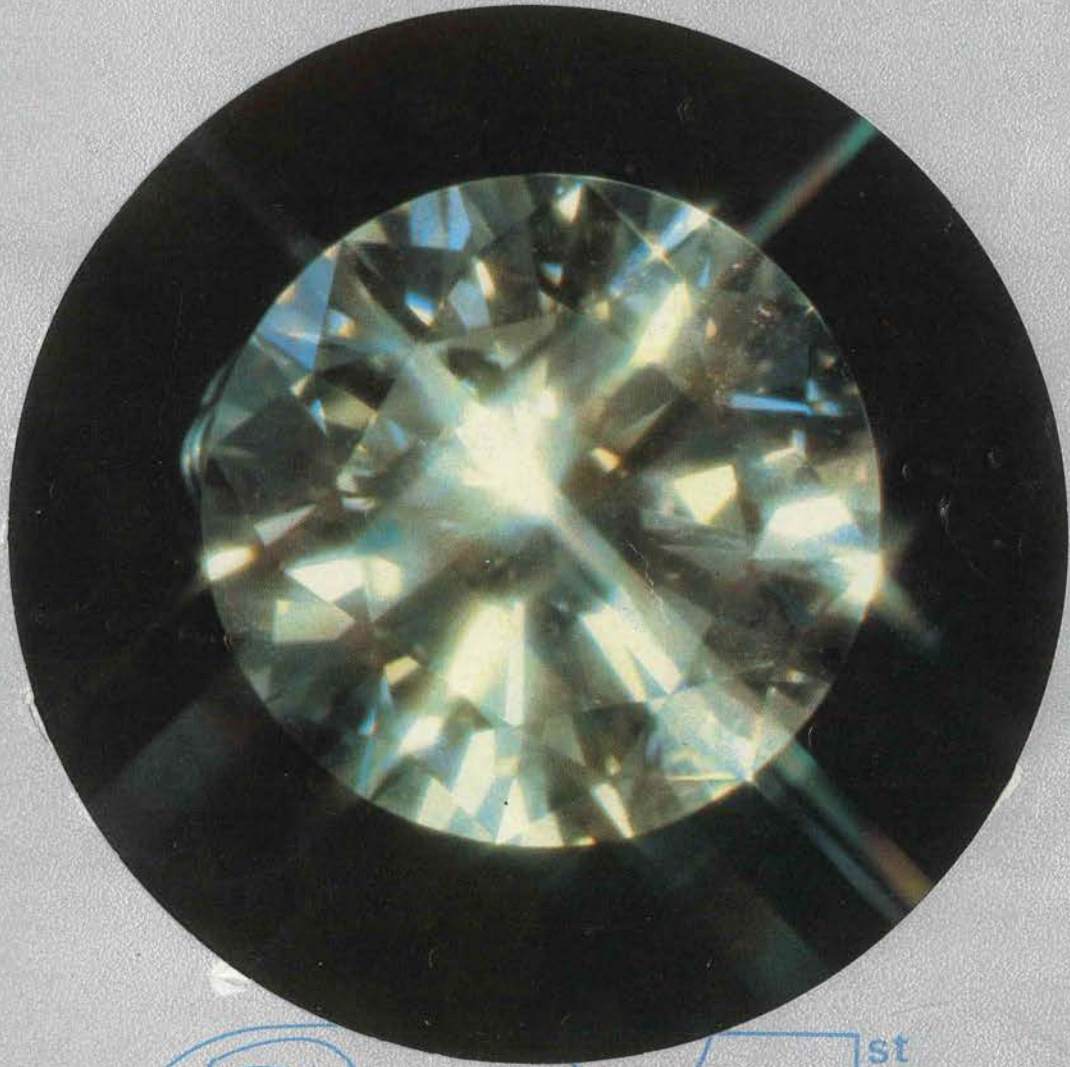


This work is licensed under a [Creative Commons Attribution-NonCommercial-Share Alike 3.0 License](#)

APRIL 1982

et al.: H & V News : 21st Anniversary Issue  
IRELAND'S BUILDING SERVICES MAGAZINE

# H&V NEWS



21<sup>st</sup>

ANNIVERSARY ISSUE

IRELAND'S BUILDING SERVICES MAGAZINE

# H&V NEWS

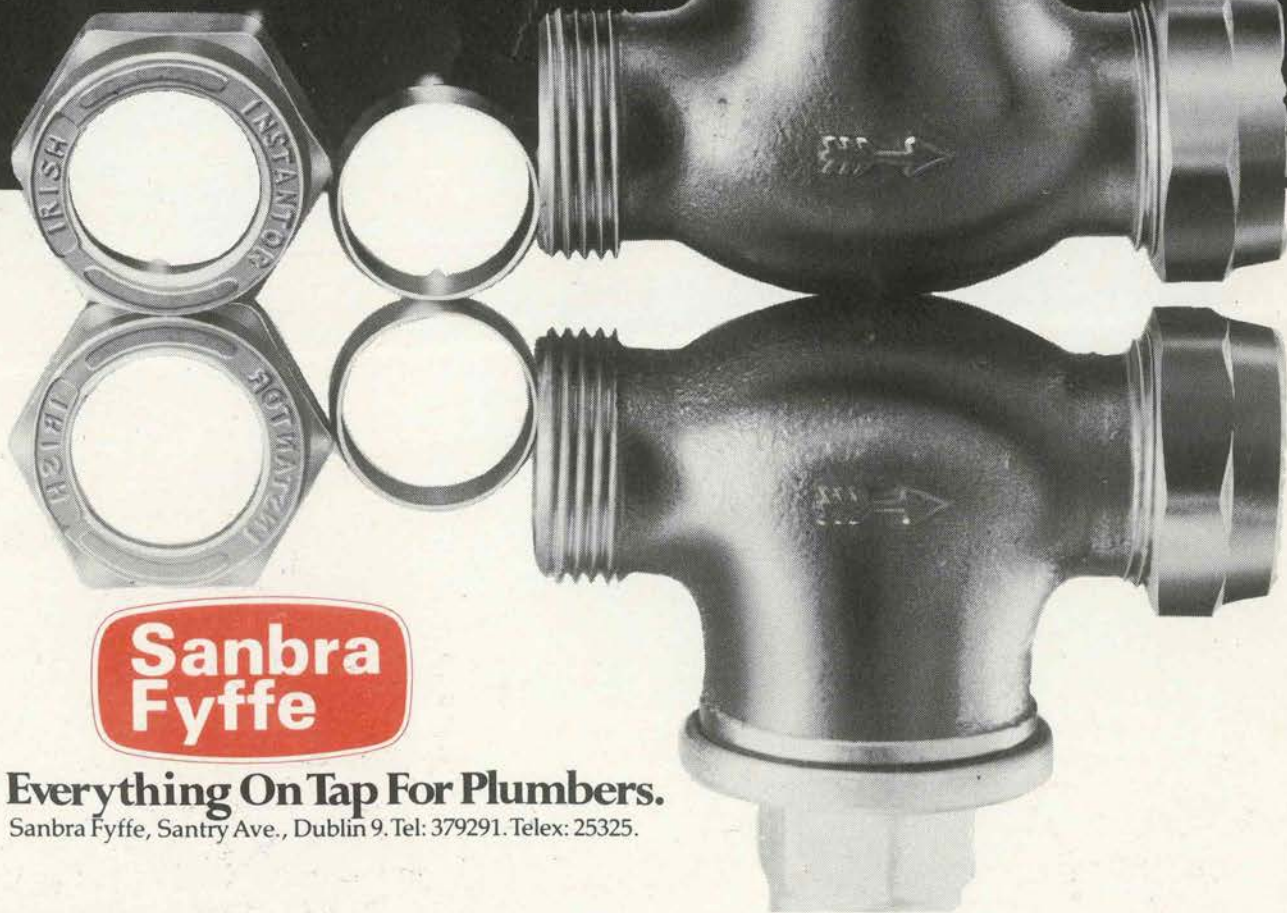


In this our special issue to celebrate 21 years of publishing Irish H&V News, we have commissioned a number of special articles, listed associations and professional institutes, we have a quiz with a case of wine as the prize, and many other 'specials' which we hope will make this issue worth keeping as a memento of 21 years of Irish H&V News.

**\*Complying with IIRS specification  
(IS 239: 1980)**

# Join the top brass.

IRISH INSTANTOR® – Full range of over 300 Couplings for connecting copper and polythene tubes. Made in Ireland since 1934. Solid, reliable and backed by first class service. New bright and shining finish, easy to identify as the market leader. The Irish Instantor® range complies with the Irish Standard Specification for Compression fittings issued by the Institute for Industrial Research & Standards I.S. 239: 1980. We are the Top Brass. Irish Instantor® – Meigirí na hÉireann.



**Sanbra  
Fyffe**

**Everything On Tap For Plumbers.**

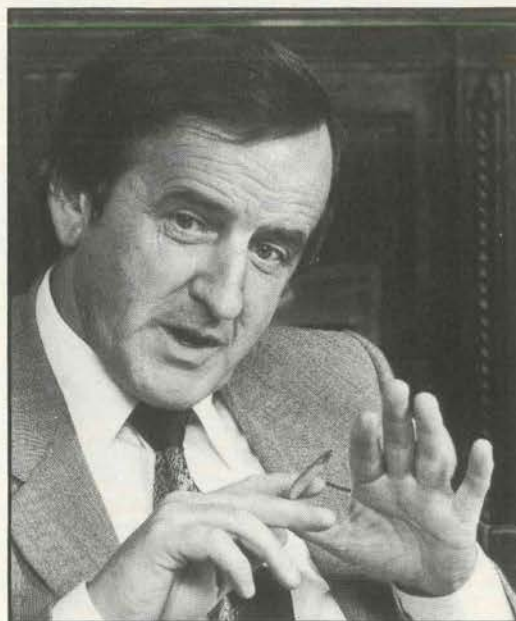
Sanbra Fyffe, Santry Ave., Dublin 9. Tel: 379291. Telex: 25325.



OIFIG AN AIRE TIONSAIL AGUS FUINNIMH  
(Office of the Minister for Industry and Energy)  
BAILE ÁTHA CLIATH 2.  
(Dublin 2.)

26th March, 1982.

Mr. Ray Loughran,  
Editor,  
Irish H&V News,  
5-7 Main Street,  
Blackrock,  
Co. Dublin.



Dear Mr. Loughran,

It gives me great pleasure to congratulate H&V News on reaching its coming of age.

“Coming of age” is not quite accurate as this magazine has been performing a very useful service now for a number of years. It has a particular interest for me in the importance it has attached to energy saving. Very often, its articles mirror elements in the energy conservation programme being pursued by my Department. This is especially true in the articles it has printed over the years on energy management and proper control/auditing of energy consumption. It has also provided data on very valuable case studies of successful energy conservation projects.

The magazine plays a significant role in the general building industry and I know that it is highly regarded by those engaged in the heating, ventilation and building services industry.

I would like to compliment H&V News on the high standard it has reached and is maintaining.

Here's to the next 21 years.

Yours sincerely,

Albert Reynolds, T.D.,  
Minister for Industry and Energy.

NEWS

# Solar Energy in Europe

At a recent meeting in Brussels sponsored by the Commission of the European Communities, decisions were taken aimed at promoting cooperation in the field of solar energy in Europe.

A Conference of European Societies for New and Renewable Energies was established, with as founder members organisations from the Netherlands, Switzerland, Austria, West Germany, Portugal, France and Ireland. Ireland was represented by past-Chairman of the Solar Energy Society of Ireland, J. Owen Lewis.

The Conference has the following objectives:

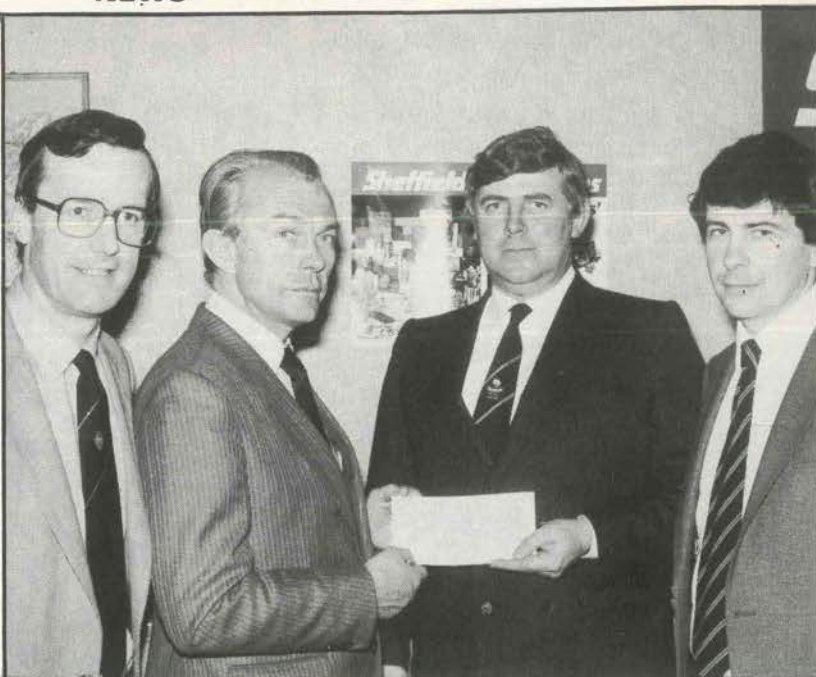
- Promote the development and use of solar energy in all its forms in European countries.
- Strengthen the efforts of participating societies and minimise unnecessary duplication of effort.
- Undertake specific activities to promote cooperation within Europe to further these objectives.

**Activities**

1. Coordinate the timing of future meetings with an international dimension at a European level.
2. Disseminate information on meetings, studies, and publications on renewable energies and exchange newsletters and speakers.
3. Seek dialogue with relevant official national and international institutions.
4. Consider the future establishment of a European Solar Foundation.

For further information contact: J. Owen Lewis at 694083 (office) or 305387 (home). Solar Energy Society of Ireland, c/o School of Architecture, University College Dublin, Richview, Clonskeagh Road, Dublin 14.

● Pictured recently at the Sheffield Insulations reception, to announce details of the sponsorship of the IRFU Leinster Branch under 19's tour of Northern England earlier this month are (left to right): John Butterly, chairman of the Leinster Branch U-19's Selection Committee, Eddie Egan, tour manager; Don Scannell, managing director and Tadgh Gleeson, financial director of Sheffield Insulations.



## Finheat — New Satchwell Distributor

Finheat Limited, well known in the heating and ventilating industry in Ireland, has been appointed a distributor by Satchwell Control Systems Limited. Finheat, which has particularly wide experience on the

electrical side of the business, is well qualified to handle Satchwell's control systems, which are in the forefront of the application of microelectronics technology in the heating and ventilating industry.

## Thermplant Launch New Gas Division

Thermplant Engineering Limited launched a new Gas Division with a very successful trade exhibition in the Burlington. The new range of equipment which will be handled by this division includes:

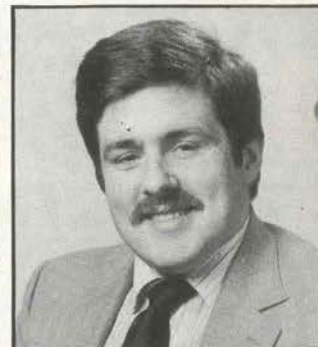
- (1) Gas Fired Boilers up to 70,000 lbs/steam/hr
- (2) Gas leak detection equipment from Oldhams of France
- (3) Gas meters both domestic and industrial manufactured by Elster of Germany
- (4) Gas approved ball valves by Orseal of England and control valves, filters, governors, etc.

Mr. John Hoey, Managing Director of Thermplant stated that it was the company's intention to build a strong division to cater for the future needs of the country when the natural gas pipeline is completed.

The exhibition was very well attended by Consulting Engineers and Gas Company representatives and Industrial Engineers. The degree of interest shown in the products displayed was extremely encouraging.

## APPOINTMENTS

● Thermal Insulation Distributors Ltd., a member of the Jones Group of Companies, has made the following additions to its technical sales force. Mr. Declan Carroll M.R.I.A.T. is well known in the Industrial Insulation Sector of the building industry having spent the last two years with Cape Insulations Ltd. Declan will service the South Leinster and East Munster areas for T.I.D. Mr. Harry Jordan M.I.E.T. a familiar figure in the construction industry for the past six years is resident in Drogheda and will take care of T.I.D. customers in the North Leinster and Connaught sectors.



● Declan Carroll



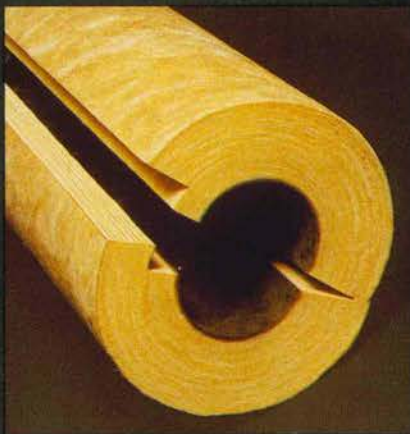
● Harry Jordan

# CROWN PIPE INSULATION

## The new one.

The new Crown Pipe Insulation has an outstanding advantage that only Fibreglass can provide. It has Z-lock: an interlocking, heat-conserving seal along the opening edge of thicker walls.

That's one reason why we believe it's superior to any other pipe insulation; but it's not the only reason.



Crown Pipe Insulation is a brand new product produced on brand new computer-controlled production lines. So we've been able to give it ALL the advantages.



Snap-on application. Smooth interior and exterior surfaces. A dense, closely-interwoven structure that's hard to tear or compress – but easy to cut and shape. Alternative wall thicknesses that make it easy to attain an economical thickness of

pipe insulation. A choice of sizes that could make your 'special' a standard.

We've given Crown Pipe Insulation either traditional canvas or multi-purpose never-rot, never-age Class 'O' facing.

Even the cartons are the right size, shape and weight to encourage safety on site.

Hence the claim that Fibreglass Crown Pipe Insulation has ALL the advantages. Which, of course, you can easily prove for yourself by sending for the new Crown Pipe Insulation brochure.



# Fibreglass

the best way to say insulation

Fibreglass Limited, 21 Merrion Square North, Dublin 2. Telephone: Dublin 767060 and 762395.

A subsidiary of Pilkington Brothers P.L.C.



NEWS



● Brendan Kilgallon has been appointed Sales Director with Alpha Controls Ireland with responsibility for the companies activities throughout Ireland. Alpha Controls Ireland are based at 13 Upper Lad Lane, Dublin 2, tel. 602711. Mr. Kilgallon is widely known in the air conditioning industry, having been employed for eight years with Walker Air Conditioning, latterly as Sales Manager. He was winner in 1980 of the Smurfit Group Executive of the Year Award.

## Wavin Pipes for Waterford Gas

Wavin Pipes Limited, will supply gas distribution piping and fittings to Waterford Gas. The Wavin Gas system will be used for gas distribution in a new supply area.

This is Wavin's first order for the distribution of natural gas in Ireland though it is extensively used for this purpose in the U.K., Germany, Holland and other European countries.

Wavin Gas has, however, been employed in Ireland for many years in Calor-Kosangas industrial and housing installations. Developed in the U.K. in co-operation with the British Gas Corporation, the Wavin Gas piping system will be manufactured by Wavin Pipes Limited at its factory at Balbriggan.

Wavin brings to the gas industry 24 years of pipe manufacture in Ireland and a high performance gas system backed by technical know-how, experience and a reputation for reliability.

## £20m LPG Underground

Cavern Systems Dublin Limited lodged an application recently with Dublin Corporation for planning permission for a £20 million LPG underground facility in Dublin Port. The project has major national energy implications and benefits and will employ over 60 people.

Cavern Systems Dublin Limited is a limited company owned by Calor

Gas Ireland Limited, Conor Holdings Limited, the Roche family investment vehicle and Mundogas SA, part of the P & O Shipping line.

The facility, which will have an underground capacity of 200,000 cubic metres, will consist of three rock caverns which will be excavated 120 metres below the ground. It will incorporate all the necessary above

and below ground equipment and systems to process and handle LPG. When fully excavated, two of the caverns will measure 260 metres in length, while the third will be 360 metres long. All will be 15 metres wide and 16 metres high. Once the caverns are excavated, they will then be cooled to produce an ice envelope around each of them. Two of the caverns will be utilised for propane (at -38°C to -43°C) with the third for butane (at -12°C to -15°C). Refrigerated LPG is pumped into the caverns and the temperature is maintained by surface refrigeration plant.

The five acres site for the proposed facility is off the Tolka Quay Road extension close to the existing Calor Kosangas overground storage facility. Dublin Port and Docks Board have given the necessary agreement in principle to lease a site in this area.

The storage of petroleum products in underground caverns is a proven technique already used in many countries. In America over eighty such installations exist. Other countries utilising this technique include Sweden, France, Italy, Japan and Holland. At present the UK is planning two similar storage facilities. Total existing underground rock storage worldwide for petroleum products is approximately 60 million cubic metres.

The technology being used in the Dublin project has been developed by Esso, the world's largest oil company. Esso began constructing underground rock caverns in Sweden in 1964. Since then they have developed their technology to such a degree that they now sell it under licensing agreements having Esso's full backing. Esso (EXXON) in New York, have approved the allocation of a licence to Cavern Systems Dublin Limited and their consultants.



● The proposed site for the £20m LPG underground storage facility in Dublin Port.

## Energy Waste in Irish Industry



● Industry in this country can be wasting 25% or more on its energy bills. This was stated in Dublin by Mr. Gil Warnock, Chief Executive of PA International Management Consultants Ltd., at a seminar for industrial and commercial leaders. He said that experience has shown that cost savings of this order could be achieved through increased cost awareness, the right choice of fuel and a use of new technology. Over a recent period international industry had spent £2m on energy consulting fees and average cut backs of 23% had been achieved which meant that some firms had saved appreciably more. Present at the seminar which was held in the Berkeley Court Hotel were (left to right): Mr. P. J. Doyle, H. A. O'Neils; Mr. Val Gunning, Calor Kosangas; and Mr. Gil Warnock, PA Management Consultants (I) Ltd.



At Expoclima Hevac, from 24th to 28th May 1982, it can take just one day to save months.

Months of research and investigation into international technologies and products.

Because in a few hours, you can bring yourself up-to-date with all the latest product developments and improvements.

And at the same time, win a holiday for two worth up to £2,000 in our special free computer draw on unduplicated registered entries.

So you can not only end up in the Caribbean, but you can do your job more efficiently, specifying and buying precisely and accurately over the widest range of heating, ventilating, and air conditioning products.

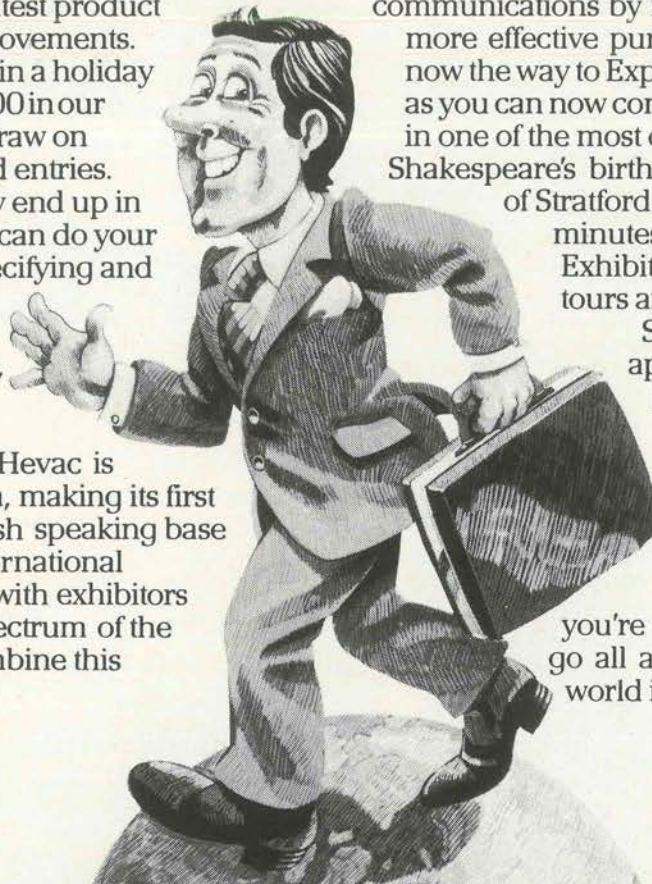
Moreover, in 1982, Hevac is twinned with Expoclima, making its first appearance in an English speaking base and bringing a new international dimension to the show, with exhibitors from an even broader spectrum of the European industry. Combine this

with the special Domestic section, and you've got the whole world of heating, ventilating, air conditioning, refrigeration and air movement in just a day.

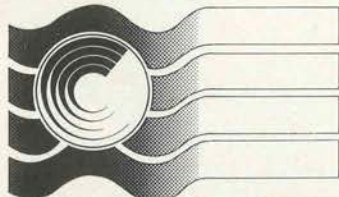

With the National Exhibition Centre's superb communications by road, rail, and air, the way to more effective purchasing and specification is now the way to Expoclima Hevac 82. (Especially as you can now combine business with pleasure in one of the most delightful parts of England - Shakespeare's birthplace, the Elizabethan town of Stratford-upon-Avon, is within 30 minutes drive of the National Exhibition Centre. Special package tours are available.)

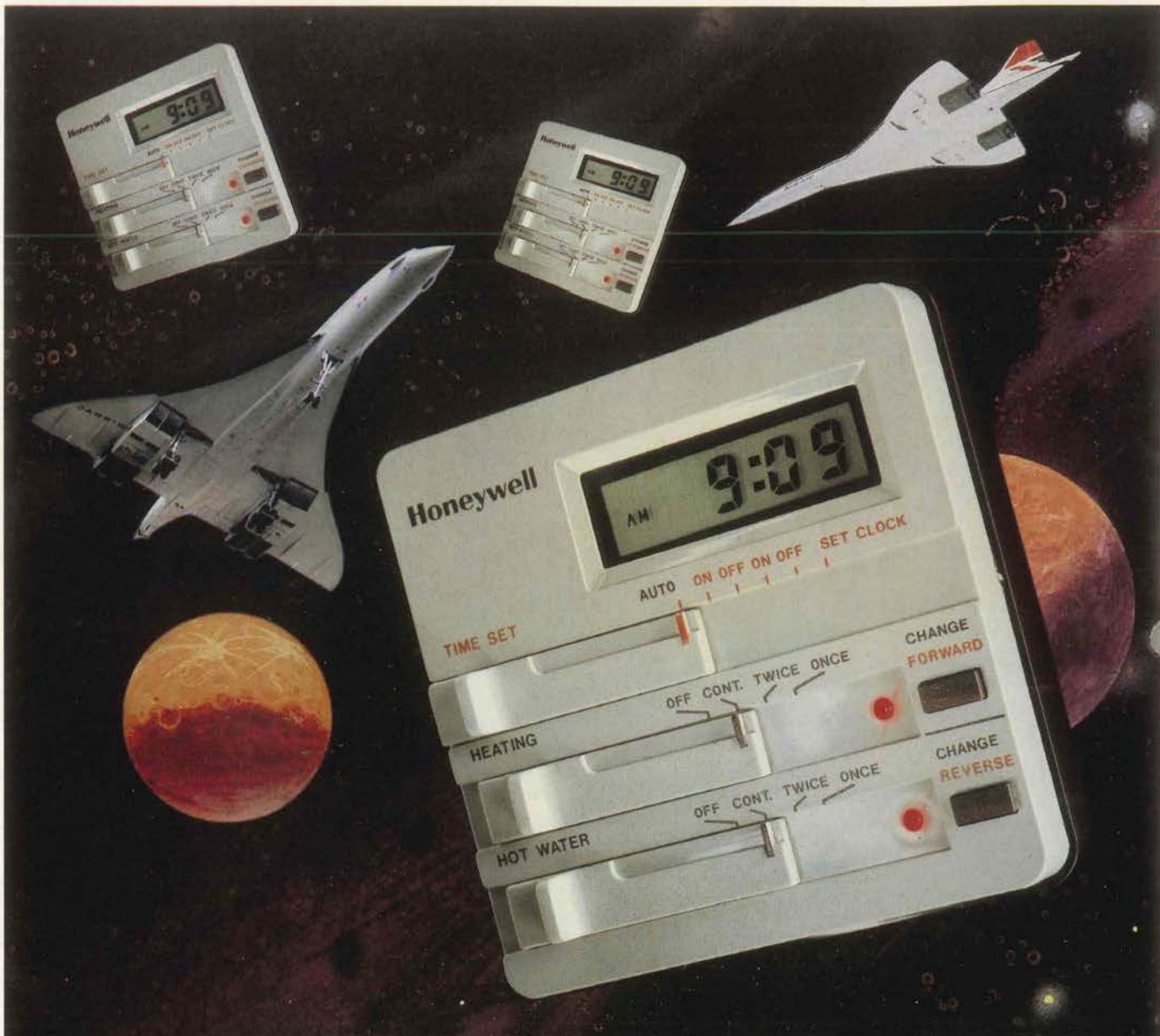
Special free entrance facilities apply on the Monday and Friday and for organised coach trips on any day subject to the exhibition organisers being notified in advance. Other days - paid admission.

Make sure you're there. And go all around the world in just a day.



# All around the world in just a day.

 <p><b>EXPOCLIMA Hevac 82</b></p> <p>24-28 May 1982 National Exhibition Centre, Birmingham. Organised by Industrial &amp; Trade Fairs Limited.</p> 	Please send me further information about Expoclima Hevac '82
	Name _____
	Company _____
	Address _____
	IHVN
	Send to: M. Coverdale, Industrial & Trade Fairs Limited. Radcliffe House, Blenheim Court, Solihull, West Midlands B91 2BG. Telephone 021-705 6707 Telex 337073



# FLY WITH THE NEW TIME LORDS

Acknowledge the new Time Lord — Honeywell's amazing ST699B Time Controller — a microchip miracle with digital readout that stays in minute-by-minute control of today's central-heating systems.

Its aristocratic features include instant manual override and an independent once-by-day function. It allows either domestic hot water or heating to operate independently of each other. And a back-up battery safeguards all functions during power cuts and holiday switch-offs. When power is restored, the battery is automatically recharged. No resetting of times required.

Put it in overall charge of Honeywell Sundial controls — the T6160 Roomstat, the L641A Cylinder Stat, the VT100E Thermostatic Radiator Valve and the V4043H or V4073A Zone Valves. And you have a system that makes extra profit for you and saves money for your customers.



Please tell me more about Honeywell Sundial controls and how I can win a free Concorde weekend.

Name \_\_\_\_\_  
 Address \_\_\_\_\_

Post to Criss Connor, Residential Division, Honeywell Control Systems Limited, Charles Square, Bracknell, Berks RG12 1EB. Telephone No: (0344) 24555

NEWS

# Gelman Open New Irish Manufacturing Plant

Gelman Ltd., previously a solely marketing/sales operation in Ireland recently announced the opening of a manufacturing facility to service the domestic and European export markets.

Gelman Sciences Inc. is a leader in the development and manufacture of micro-filtration products and systems and biomedical apparatus, serving the health care, laboratory and process industries worldwide from operations in Ann Arbor, Michigan; Northampton, England; Brussels, Belgium; Sydney, Australia; Montreal, Canada and now Dublin.

Exports of GA membrane filtration material and Sraphore III membrane products for laborat-

ory and diagnostic testing have already started from the Dublin plant.

The manufacturing facility has been designed to provide 1,500 sq. ft. of Class 10,000 clean room conditions to meet F.D.A. regulations and to avoid airborne particle contamination.

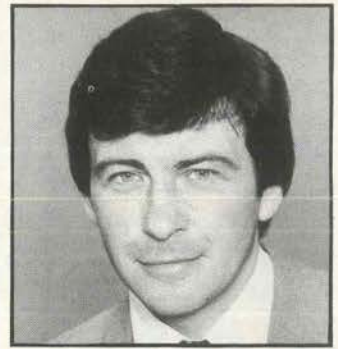
Gelman Sciences Inc. have also formed another wholly owned U.S. subsidiary company in Ireland, Gelman International Ltd., whose role will be to import raw materials and export the finished products manufactured by Gelman Ltd. in the new Tallaght headquarters.

Mr. John Lyons, Executive Director of the Industrial Development Authority,

officially opened the new Gelman premises on Wednesday, March 10th.

Mr. J. Marshall, Vice-President, Gelman Sciences Inc. was also present at the official opening. In a brief speech Mr. Marshall said he looked forward to the expansion of the Irish manufacturing facility and hoped Gelman could play a part in providing employment for young people in the progressive, technological field of membrane filtration. There was increasing worldwide demand for the Gelman range of specialist laboratory equipment and he was very pleased that Ireland had been chosen as a European manufacturing and distribution base.

APPOINTMENTS



● Mr. Tadhg Gleeson has been appointed a Director of Sheffield Insulations (Ireland) Limited, and now assumes the role of Financial Director and Company Secretary.



● Wavin Pipes Limited, announced the appointment to the Board of Mr. John D. Hourican, Financial Controller of the Company.



## WIN A FREE CONCORDE TRIP FOR 2 TO NEW YORK & BERMUDA

Here's another reason for installing Honeywell Sundial controls. It all starts at Hevac 82. Just come to the Honeywell stand (or send off the coupon) to find out how simple it is to win the greatest time you've ever had — a super luxury long weekend for two — flying by Concorde to New York and Bermuda next October!

Second prize is a weekend in Paris, Gleneagles, Brussels or Copenhagen — the choice is yours. Third prize consists of time-of-your-life vouchers that could make all the difference in the world to your next holiday: they could help you to Florida, or Singapore, or anywhere else you have a fancy for!

Find out all the details at  
**Hevac STAND IB22**  
**Honeywell** the household name

Honeywell Control Systems Limited, Charles Square, Bracknell, Berks RG12 1EB. Telephone No: Bracknell (0344) 24555.



VT100E Thermostatic Radiator Valve



T6160 Roomstat



L641A Cylinder Stat



V4043H Zone Valve



V4073 A Zone Valve

## Further Expansion for Walker

Continuing Walker Air Conditioning's policy to expand the services offered to its customers, they have acquired two new franchises in the past twelve months. Walkers recently held an Open Day on which they exhibited products from both manufacturers,

namely, Holland Heating B.V., a Dutch manufacturer, founded in 1955, whose products include air handling units with capacities ranging from 0.3m<sup>3</sup>/sec. to 70m<sup>3</sup>/sec., roof extract fans, tower louvres and extruded aluminium dampers. They also announced that

they have recently been appointed the sole Irish Distributor for Heenan Marley Cooling Towers Ltd., this well known range of cooling towers. In addition to the well known "4400" towers and "NC8600" towers, their range now also includes a series of counter-

flow induced draft plastic towers, (series QMA), counterflow forced draft towers (P-type) and closed circuit forced draft counterflow towers (series C). A sample range of these towers were on display for examination.



● Pictured at the Walker Air Conditioning Ltd. open day were (l-r) Jim Anderson, Managing Director, Walker Air Conditioning Ltd.; Matt McKeon, McKeon Bros. Ltd. and Stewart Roche, Director, Walker Air Conditioning Ltd.



● Having an enjoyable evening at Walker Air Conditioning Ltd's open day were (l-r) Gerry Ross, Sales Manager, Walker Air Conditioning Ltd.; Michael Carroll, J. V. Tierney; and Paul Abell, Climate Engineering Ltd.

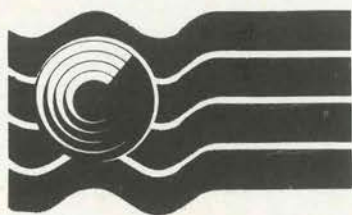


● Photographed at the Walker Air Conditioning Ltd. open day were (l-r) Mike Bunn, Gerry McGinley and Gary Holmes.



● From the AIB premises dept at the Walker Air Conditioning Ltd. open day were (l-r) Brian Hannan, Michael O'Dwyer, and Liam Conway.

TRAVELLING TO



# EXPOCLIMA Hevac 82?

National Exhibition Centre, Birmingham 24-28 May 1982

The twinning of Expoclima to the Hevac '82 exhibition combines the two top European shows to provide an event of outstanding international status. Special arrangements have been made by Irish H&V News to cover travel and accommodation. For further details contact: Victor Gibson, H&V News, 5/7 Main St., Blackrock, Co. Dublin. Tel: 885001.

NEWS

## Trianco Multi-Fuel Stove

Trianco Redfyre Ltd. has just launched its much-heralded International multi-fuel stove. Described as a breakthrough in appliance design, this purpose-built stove has been the subject of an intensive development programme at TR.

The primary feature of the International is its ability to burn with optimum efficiency a wide range of solid fuels. Most other stoves currently available are designed to burn wood with coal as the secondary fuel, but the International will burn either coal or wood as a primary fuel.

The appliance has a number of additional technical features which it is claimed are unavailable on other stoves.

For example maximum user convenience is provided by a patent-applied for device which, by simple lever action, automatically converts the universal fire grate from coal to wood burning. The lever also changes the air flow direction to maintain optimum combustion efficiency at all times.

Described as a major advance in appliance design, the International's firebed mechanism obviates the need to change the physical arrangement of the firegrate whenever a different fuel is used, which is a tedious operation with most other multi-fuel stoves. The frontal appearance of the International is enhanced by an exclusive one-piece, up-and-over door which allows simple conversion to open fire operation if desired.

Two versions of the stove are offered. The manually-controlled dry version has a total space heating output of up to 45,000 Btu/h (38,500 convection and 6,500 Btu/h radiation sufficient to heat a space of 8,200 cu ft) while the thermostatically-controlled boiler version has an output to water of 33,500 Btu/h with up to 12,000 Btu/h for direct room heating. Prices around £440-480 + VAT depending on model.

Both versions have been built for overnight burning and can be installed up to a standard fireplace openings. Chrome iron fire bars and a purpose-built ash pan/ash carrier are fitted as standard. Overall dimensions of the stove are width 640mm, height 765mm and depth 455mm (excluding flue spigot when fixed for rear offtake). Initially two colours are being made available: Black and stainless Steel super de luxe.

Further details of price and availability from Heating Distributors Ltd, Tel: 375144.



● Pictured in Dublin recently at the Eastern Region of the Energy Managers Association were (l to r) Pat Dineen, Manager, Dairy Products Division, Waterford Co-operative Society Ltd.; Gerry O'Neill, Energy Manager, Irish Co-operative Organisation Society, Dublin, and Peter Brabazon, Energy Conservation Officer, Energy Managers Association.

**I.I.R.S. TESTED**

**The Unidare**

**3★ ★ ★**

**GENERAL**

**wins the cold war  
on every front**



★ **New standards of efficiency in room heating replacing inefficient open fires.**

★ **Produces domestic hot water and radiator heating.**

★ **Especially suitable for turf briquettes, turf, coal, anthracite and other smokeless fuels. No need to rely on one fuel source.**



**UNIDARE**  
makes life better

Finglas, Dublin 11. Tel. (01) 771801.

## Solar Thermal Appliances in Buildings

The CIBS held a Group Heating Technical Evening recently on "Solar Thermal Appliances in Buildings" the speakers was J. Owen Lewis — Energy Research Group UCD and "Group Heating and combined Heat & Power" with Peter Byrne — Chairman of Energy Conservation and District Heating Association of Ireland giving the details.

The theme was changes in energy prices and availability have given new importance to non-conventional sources of energy in buildings. Among the more important areas receiving attention world wide are solar energy and waste heat utilisation.

J. Owen Lewis reported on the monitored perform-

ance of a number of solar heating installations in European buildings, and discussed future directions in Solar Water and Space Heating.

Peter Byrne discussed present trends and review recent developments in combined heat and power systems in Irish Buildings with particular reference to Department of Energy supported projects.

A lively discussion session concluded the meeting. This technical evening was sponsored by M. + G. Ltd. and Calor Kosangas and the first pint of the evening was free.

**P.S. The Annual Gold Outing has been transferred from May 14th to May 28th, 1982.**



● Photographed at the recent signing of the contract for construction of the Cork-Dublin natural gas pipeline at the Bord Gais Eireann Head Office, Little Island, Cork were (front row left to right): Mr. Eddie Collins, T.D., the then Minister of State at the Department of Industry and Energy, the then Tanaiste, Mr. Michael O'Leary T.D., Minister for Industry and Energy, Mr. Richard Moylan, Acting Chairman, Bord Gais Eireann, Mr. Nevin Dowling, Chief Executive, Bord Gais Eireann, and Mr. Sean O'Sullivan, Director, Bord Gais Eireann. Included at back are Mr. J. C. Wallace, Managing Director, Irishenco, Mr. Rudi de Waard, Managing Director, Nacap b.v. and members of Bord Gais Eireann.

## Vent-Axia Extract/Intake Ventilation Units

Vent-Axia produce two ranges of extract/intake ventilation units, providing a total of over 50 different models. The Universal range comprises size 12 (305 mm), size 9 (229 mm), size 7 (191 mm) and size 6 (152 mm), all available in window, roof, wall and panel units. The range is specially designed to incorporate the qualities of long life, quiet operation and minimum maintenance and all units feature one of Vent-Axia's exclusive developments, the Autospring shutter — which operates perfectly at whatever angle the unit is installed.

The models in the Universal range are finished in tundra to blend easily with most backgrounds. The Vent-Axia Standard range is available in the same sizes and models as the Universal range, but in black or ivory finish. For both ranges there are Rangemaster controllers to vary the speed and direction of air flow.

Vent-Axia produce a complete range of Ventilation Accessories to make this sort of installation simple and effective. These Accessories increase the versatility of the fan units, providing a complete ventilation deal. Application techniques are simple, thus filling the gap between expensive complicated central ducted ventilation systems

and the basic fan in the office window. The range includes a wide selection of grilles, plates, louvres, flexible ducting, filters and fire dampers. Installation costs using Vent-Axia equipment can be at least 50% lower than the cost of installing central ducted systems. The extensive range of accessories makes installation simple, even in roofs and walls where accessibility would normally be difficult. Many modern buildings have widely spaced double windows to minimise traffic noise and this presents no problem, as Vent-Axia fans can be split into two halves and, with additional accessories, mounted offset in the window panes so that sound cannot pass straight through into the room. Although the importance of air extraction has been stressed, the ability of Vent-Axia fans to be reversed is particularly useful in very hot weather when the turbulence caused by air being pumped into the room can give added relief to the occupants.

A comprehensive ventilation ring binder can be obtained from Vent-Axia Division, GKN Autoparts (Ire) Ltd., Camac Close, Emmet Road, Inchicore, Dublin 8. (Tel: 781700 Telex: 30830).

## STEAM PRODUCTION AND HEATING EFFICIENCY START WITH A ROBHEY BOILER AND GO ON AND ON AND ON AND ON AND ON

- 212 Boiler/Generator versions — to suit your specification.
- Coal, Gas, Peat, Wood, Oil and Waste Heat firing systems.
- Steam outputs from 1,000 to 60,000 lbs/hr.
- Hot Water Generators giving 5 to 60 million BTU's/hr.

S.L. COMBUSTION SERVICES LTD. LAHERDANE, BALLYVOLANE, CORK Tel: 501411  
158 CASTLEREAGH RD., BELFAST BT5 5FT. Tel: Belfast 59282



# ROBEY



boilermakers of international repute

# Build for the future with Coal



## 1 Roomheater

Whole house heating from a living fire behind a glass door.

## 2 Back Boiler

Heat 5 rooms and all the hot water you need from one open coal fire.

## 3 Gravity feed boiler

Elegant coal burners for whole house heating that need minimum attention. Choice of other independent boilers.

## 4 Cookers

Many of today's solid fuel cookers heat radiators as well.

## or Interlinking

The traditional coal fire can now be Interlinked with other hot water radiator systems reducing your heating costs substantially.


And there's plenty of coal in the world!



# COAL is the answer

Contact your coal merchant or Coal Information Services, 18 D'Olier St., Dublin 2. Tel: 776246

The fuel for today — and tomorrow



## HALIFAX FANS still as efficient & reliable as ever.

The result of many years of engineering design and development, HALIFAX FANS are built for quality, reliability and efficiency, using the most advanced machinery and specialised personnel.

Available in a wide range of forms to serve a variety of industrial uses, HALIFAX FANS are on duty in the Chemical and Paper manufacturing industries, Food, Grain and Wool handling operations, in Computer installations, aboard Oil Tankers and in many other applications.

### HALIFAX FAN

HALIFAX FAN MANUFACTURING CO.  
(INTERNATIONAL) LTD.  
Mistral Works, Rookery Lane, Salterhebble, Halifax,  
West Yorks, England HX3 0PY. Tel: 0422 56776. Telex 51460  
Specialists where service and quality count.

## NEWS

## SUPERJET IN IRELAND

Superjet are producing a range of Irish manufactured gas/oil burners in a range from 70,000 Btu/h to 5 million Btu/h which will be available ex stock and backed by commissioning and service facilities.

Superjet (I) Ltd., are in a position to offer the trade the following facilities:

The company's main activities are:

**MANUFACTURE:** Both gas and oil burners in a range from 70,000 Btu/h to 5 million Btu/h will be manufactured and will be available from stock.

**SERVICE & COMMISSIONING:** All burners manufactured by Superjet Ireland Ltd., and annual service contracts offered on request. A reliable commissioning and service base has been established over the past two years under the name First Technology Heating Ltd., who will continue with this work on behalf of Superjet.

**REPAIR SERVICE:** Fast facility will be offered to have central heating burners repaired and tested in the company's workshops.

**TRADE COUNTER:** A city centre trade counter

will be available to the industry which will include gas/oil central heating burners also:

Spares and EG probes and control boxes. Gas valves and UV sounds and fans and electric motors. Pipework and fittings, etc.

The company is at Temple Lane, Hill Street, Dublin 1. Tel: 742855 Telex 32941.

Superjet Ireland Ltd. commenced production of Irish built oil and gas central heating burners on the 1st March and initially employed 10 people at their premises of 7000 sq. ft. in the old Kennedy bakery off Parnell St., Dublin. The

number of employees is expected to expand rapidly to 30.

The directors, Louis Costello, Joh McNerney and Tommy Byrne, formed a company First Technology two years ago with the object of ascertaining the potential of energy related fields. It identified a major gap in the manufacture of oil and gas central heating boilers. Consequently the company set about bridging the gap and this led to the formation of Superjet Ireland Ltd.

Superjet successfully negotiated a manufacturing licence with Radiant Superjet Ltd. of Clapgate Lane,

Woodgate, Birmingham, a subsidiary of the Norcross Group of companies.

The IDA Enterprise Development Section approved a suitable grant aid package to assist this new industry to get off the ground. It is the first time that these types of units have been manufactured there.

Superjet will manufacture a range of both gas and oil burners from 70,000 Btu/h up to 5 million Btu/h and they will also feature a trade counter where spares for central heating burners will be available.

## Energy Management Association

Starting its second year in operation the Energy Managers Association has grown from strength to strength. It was established

in early 1980 by the Institute for Industrial Research and Standards, and is funded by the Department of Industry and

Energy.

Membership is free and open to those responsible for the use of energy in industrial and commercial enterprises, local authorities, health and educational establishments and public buildings.

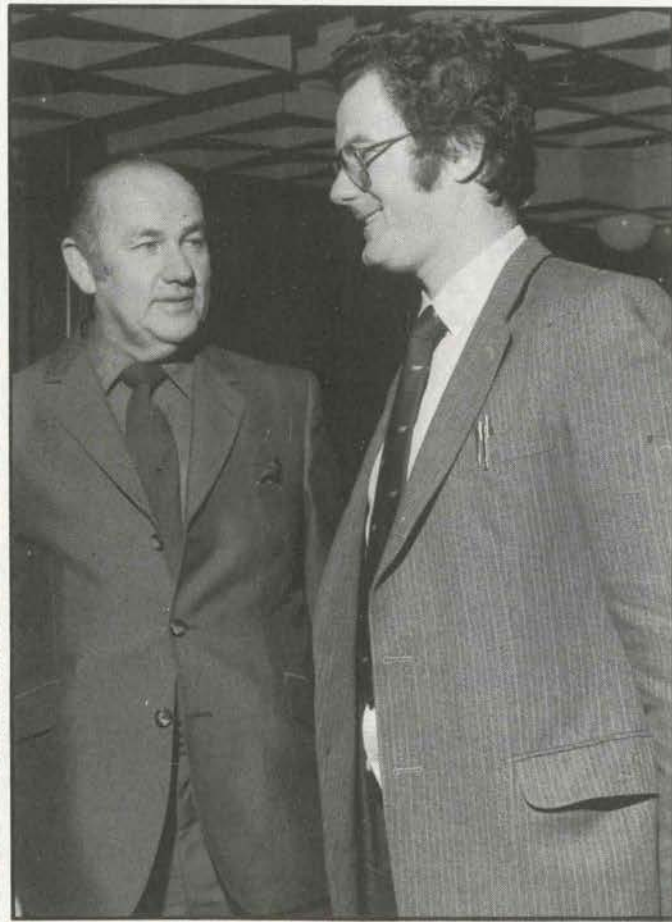
Its aims are:

- to promote energy conservation in industry, commerce and the public sector;
- to encourage the establishment of an on-going energy conservation programme in every industrial and commercial enterprise in the country;
- to provide a forum for the exchange of information and practical energy conservation techniques.

Each regional branch committee has representatives of the CII, CIF, ICTU, the Association of Consulting Engineers and the Institution of Engineers of Ireland.

The Association has four regional branches based in Cork, Dublin, Shannon and Sligo respectively. Regular meetings are held throughout the year in selected regional venues.

The National Organiser is: Mr. Harry Pattison, Energy Management Association, IIRS, Ballymun Road, Dublin 9, (Tel: 370101).



● Pictured at the Eastern Region Energy Managers Association in Dublin during a break in the meeting were (l-r) Harry Pattison, National Organiser of the Association, and Jim O'Connor, Technical Development Manager, Waterford Co-op Society Ltd.

## Hoval Take Over Hartley & Sugden

The Hoval boiler company has recently purchased the full facilities of T.I. Hartley and Sugden.

Hoval's Irish agents, James Gleeson, are now assembling under licence, Hoval boilers at their Limerick factory and warehouse. Boilers assembled include sizes from 300,000 to 2 million Btu/h. The full range of Weishaupt gas and oil burners are also assembled at Gleesons.

Hartley and Sugden boilers will now be sold by James Gleeson complimentary to the Hoval range.



## PROBABLY THE LAST

# TALKING SHOP



BOB COUCHMAN



Actually I shouldn't be writing this at all. When Ray Loughran asked me to do a piece as a sort of memory lane trip to celebrate this publication's 21st year I should have reminded him that I don't actually go back the full twenty-one years. My first offering, a short series entitled "The Seven Deadly Sins of Domestic Heating Design" was published early in 1964. "Talking Shop" didn't appear until the summer of 1965 and it ran on until early 1977.

So what does one write on an occasion like this? Nostalgia isn't what it used to be (it never was!) and nobody would thank me for indulging in a lot of "do-you-remember?" stuff. Memories are personal to each of us but it's fair to say that the specialised little world, so faithfully recorded by this journal, was a happy, friendly, and exciting one, particularly during the late Sixties. The old Heating Centre in Dame Street, presided over by Gerry O'Malley, was the focus for a lot of activity and optimism. Later, of course, Ray Loughran succeeded Gerry; going further back I can remember Ray as a bright young apprentice.

Then there was the establishment of the Irish branch of the I.D.H.E. and all the fun and fervour of the early, very successful, meetings. There must have been a lot of work involved but it's the fun that I remember. Like you-know-who putting an egg in the jacket of old so-and-so's dinner jacket at one of the annual banquets. It wasn't spotted until it was much too late and there was a very sharp reaction. Or Hugh Maguire, who I think was actually Chairman at the time, discovering twenty miles on, that he had actually passed the hotel where the function was being held. Sorry! I did say I wouldn't indulge in

nostalgia, but they were happy times.

The H. and V. News, which I first knew as the Irish Plumbing and Heating Engineer, could not have survived so long if the editorial policy had been less enlightened. There are several areas where, I believe, great credit is due to the present Editor, Ray Loughran and to Gerry Murphy, who was the Editor during almost all of the period when I was a regular contributor. There is and always has been a genuine attempt to inform the reader and to discuss and become involved in the topics of the day. Very different from the endless pages of advertising material, interspersed with a minimal amount of bland, non-committal editorial work that may be seen elsewhere. Then there's the involvement. Ray Loughran, as a man who has worked in the industry, and Gerry Murphy for many years before him, have given up a great deal of precious spare time to activities like the I.D.H.E.; the rest of us have benefited tremendously from this dedication which brought little or no tangible benefit to the H. and V. News.

Another thing that I have always thought was special was the total freedom enjoyed by contributors. In all the years no-one suggested to me what I should write, or not write. In all the years no one cut a word from my copy or, to my knowledge, from the copy of any other contributor. In fact I can remember at least one occasion when a substantial advertiser objected strongly to some editorial material matter which,

while an honest expression of opinion, did not coincide with the advertiser's interests. Their objection was politely turned aside. That is the sort of stance that one would expect a national daily to adopt but it takes courage if you are editing a trade journal.

It has never previously seemed to be an appropriate time to express my admiration and appreciation of the way that the H. and V. News has been run over all these years; I am very glad to be able to do so now.

Some of the total liberty given to contributors may have drifted into license at times. I remember doing a Christmas pantomime — in verse — one year as well as getting involved in some weird and diverse writing projects including the infamous McWhinge file. There were, be it whispered!, occasional editorial mistakes like the time when one entire issue went out to a mailing list of contributors to quite another journal. For quite a long while, around 1970, things ran about six weeks behind and it never seemed to be possible to catch up with the correct publication date. At one stage the office was burned out — or at any rate well washed out by firemen's hoses.

Enough of history — what about the next twenty-one years? Well, unless the war starts and the survivors revert to living in caves there will still be a heating and plumbing industry. The men and the materials will be different but it's a safe bet that cowboy installers will still be around making more money, at least in the short term, than the honest brokers. And as for as the rest of us, well I did entitle this "Probably the last Talking Shop". In twenty-one years time I will still be under eighty — and I'd love to be asked to write another Jubilee contribution.

# BUDGET '82

BY 'GURU'

**The recent budget has caused considerable discussion in all levels of business and this month our economics correspondent Guru looks at the budget and how it will effect the building services industry.**

The recent budget has in some quarters, been called the most anti-business business in recent times. The employer bodies, like the Confederation of Irish Industry and the Federated Union of Employers, have been loud in their condemnation of it. Apart from the initial reaction of Congress of Trade Union representative, Peter Cassells, who said it was "good budget for employment", it has in the main, remained quiet. Likewise nothing has been heard from the ITGWU. This, however, is par for the course. If the unions agree, the employers disagree, and vice versa. So then, what is the true position of the budget?

Well, for one thing, in my opinion, the budget will place a terrific burden on the working capital of Irish industry, specifically manufacturing industry. I am referring particularly to the imposition of VAT on imports. This is an absurd proposal and goes against the very tenet of historical Fianna Fail Government policy, that is to solve the unemployment problem, plus the helping of Irish industry, particularly small industry. With regard to VAT, I suspect the employer bodies were wrong footed because, it did not feature in their utterings in the run up to the budget. The reason for this could have been that the original Fianna Fail proposals, as stated by Mr. Haughey on 12th February 1982, was to raise £45 million from VAT on point of imports on "non-essential goods". This, most people presumed, was the video recorders, T.V.'s etc. However, on becoming Taoiseach and with the Gregory Package to be paid for, the figure jumped to £145 million and "non-essential goods" became all imports.

Since about two-thirds of all our imports consist of materials for use

in manufacturing, the greater part of this tax now falls on the manufacturing sector. Industry representative bodies estimate that the working capital requirements would be increased by up to £90 million. The most severe impact would be on firms engaged in manufacturing for exports. At a time when interest rates are high and will remain so, due to the demands made by Government borrowing, to place an additional burden, by way of VAT on point of import can only adequately be described by quoting the well-known drink advert — "It leaves one breathless". So those in the heating and related business who are manufacturing will be hard hit. As this is the most single important item in the budget, I should like to more adequately describe this problem of Value Added Tax.

If we start with those companies exporting, we can state that no VAT is charged on goods manufactured for export to any EEC country. At present, Irish exporters do not have to pay VAT on raw materials because there is no VAT chargeable on export sales. Now, the exporter will have to pay tax on raw materials each month, and would have to apply for a refund of payment. Indications are that such refunds will take up to two to three weeks. Exporters could, therefore, have to outlay five to six weeks VAT payment on raw materials and components despite the fact that VAT is not chargeable on export products.

For those companies in the heating and related businesses, who are importing goods for use on the home market, under the present system the calendar year is divided into six VAT payments, January/February, March/April, and so on. As everybody is aware a registered trader is required to make a return and discharge his net debt to the Revenue Commissioner for each period in one sum, between 10th and 19th of the following month. Therefore, the trade obtains an average credit period of 49 days (maximum of 79 days/minimum 19

days). The net VAT debt usually consists of the total amount of VAT invoiced by the trader to his customer reduced by all VAT invoiced to the trader by home suppliers.

The new proposal, however, requires that imports charged in any month become payable on 15th of the following month and means that the debt in future will be paid in three parts. For example, the VAT charged in January imports will be paid on 15th February, and the VAT charged in February will be paid on 15th March. When the trader makes his normal return on 19th March, he will deduct his two payments from his remittance. This means that compared with the present situations, the 15th of February payment represents a reduction in credit of 34 days, while the 15th March payment represents a shortening of four days. The average reduction in credit is 19 days, which is the extent to which the Government will gain in 1982, and the extent to which working capital for companies must be increased. Therefore, whether one is importing components and materials for re-export or importing goods for the home market for re-sale, the new proposals for VAT represent an increase in the working capital. Worse still, to tax the raw materials for re-export, which is the very basis of the I.D.A. thrust for new industries, this is indeed a serious proposal.

It will be interesting to see developments as this proposal does not come into operation until 1st September. I expect a lot of flack to fly in the interim period.

In addition to the VAT problem, all of industry, both manufacturing and distribution will be hard hit by the increase of 1.75% employers contribution to PRSI. This proposal runs counter to the stated aim of Fianna Fail labour policy, that of solving the unemployment problem, particularly youth employment. The increase on VAT is a tax on employing people. It is pushing businessmen to become capital intensive and thereby reducing the number of people they employ. My prediction is that the pursuit of such policy, while helping pay for teachers/gardai/civil servants salary increases does nothing in helping the young in getting a job, does nothing to create wealth, does nothing to solve our economic problems. WE are now staring 180,000 unemployed people in the near future, all due to

irreconcilable policies.

In addition to the employers PRSI being increased by 1.75%, employees are now also subject to 2.75% in the PRSI contribution. This is a 1.75% increase, like the employers, plus a 1% increase in the youth employment levy. The problem here is as this is now being subject to an added claim by the unions on employers, which in turn is pushing up our costs, and in turn is making us uncompetitive. Agreed, in one particular case it is giving £60 million to the Youth Employment Agency, however, even though £60 million has been raised or will be raised, the problem is, where will the jobs be? In the Public Sector? This would be unthinkable. The Public Sector is already too big. In

the Private Services? Possibly, but they are dependent on manufacturing industry, I fear for manufacturing industry. So it will be interesting to see where money will be spent on the Youth Employment Agency. One thing that can be sure, it will not be spent on wealth creating activities.

As to other proposals, if you have built up a good business and are now wanting to sell the Capital Gains Tax does not help you. The reduced rates (of tapering relief) of Capital Gains Tax are to be abolished, however, the standard rate is to be increased from 30% to 40%. Short term gains are to be taxed at higher rates. Where the disposal is within one year of acquisition, the rate will be 60%. In

Where the disposal is not within one year, but within three years of acquisition, the rate will be 50%. As everybody is aware we have a special Capital Gains Tax on gains from the development land. The normal rate will be 50%, but where the disposal is within one year of acquisition, the short term gain of 60% will apply. While some of these proposals are good from a social viewpoint, it is rather like taking a meat-axe instead of a scalpel. It is regrettable that people who have built up small businesses and want to sell them are now penalised. Part of the new proposals in Capital Gains Tax are nothing except a barrier to enterprise. Unfortunately, in Ireland we need more entrepreneurship rather than less.

As everybody is also aware, the increase in the new VAT rates coming into effect from 1st May, will effect the price of all goods, whether imported or manufactured in Ireland. Given that people will probably be less well off, and that the price of goods go up we can anticipate a continuation of the recession, and the heating industry is no exception.

Finally, I would like to end by referring to the levy on the banking system. I do not propose to defend the banks, but what I will say is that the levy effectively takes £350 million out of circulation. This, together with other factors, will have a depressing effect on the economy. Given that interest rates will, by the nature of things will have to stay high, I see a situation of a continual number of company failures and an increase in unemployment. As I said in the beginning, some people said that this was the most anti-business budget, I would prefer to say it was a budget that tackled none of our fundamental problems. It did not eliminate our current deficit. It did nothing to review our capital spending and get a better return. It did nothing to reduce the losses in the semi-State sector. It did not tackle the problem of public sector pay to bring it in line with the private sector, after allowing for security of employment and inflation-proof pensions. It did nothing to develop a proper system for measurement of efficiency in control of expenditure throughout the public sector.

In essence, it was a bad budget, bad for the heating and related industries as well as prices, which must increase this year.

## Main Features of 1982 Budget

- **INCOME TAX** — restrictions on mortgage and loan interest; tax credit system abandoned; personal allowances increased; tax bands narrowed; tax on benefits-in-kind increased.
- **CORPORATION TAX** — 45% rate increased to 50%; payment dates brought forward; additional tax on banks and insurance companies; stock relief extended.
- **VALUE ADDED TAX** — 15% rate increased to 18%; 25% rate increased to 30%; solicitors and accountants no longer exempt; VAT to be collected on importation.
- **CAPITAL GAINS TAX** — 30% rate increased to 40%; higher rates for short-term gains; tapering relief abolished; 50% rate for development land.
- **CAPITAL ACQUISITIONS TAX** — gifts and inheritances to be aggregated.
- **FARM TAX** — stock relief extended.
- **EXCISE ETC.** — excise on motor fuels increased; increase in Road Tax.

### COMPANY CARS

The taxable benefit from the use of a company car will be based on a sliding scale related to the original market value of the car and varying according to whether the costs involved are borne partially or totally by the employer.

For 1982/83 and subsequent years the taxable benefits arising from the private use of a car provided by an employer will be calculated as a percentage of the original market value of the car. For 1982/83 the percentage will vary from 12.5 per cent where the car only is supplied, to 20% where all costs are met by the employer. These percentages will be increased to 25 per cent and 40 per cent respectively from 1983/84.

Where the business mileage is more than 15,000 miles in a year a system of tapering relief will apply. Persons, such as commercial travellers, with very high business mileage will be given the option of claiming further relief where it is shown that, on apportionment of the costs, the proportion attributable to private mileage is less than the chargeable benefit under tapering relief.

### BUSINESS ENTERTAINMENT

Expenditure on business entertainment is no longer deductible in arriving at taxable profits. This prohibition will apply to expenditure incurred after 25 March 1982.

## 1961

- Irish H&V News launched as The Irish Plumbing and Heating Contractor. Mrs. 1970, of Shell & BP fame, pays a visit to Dublin.
- Ireland applies for membership of E.E.C.



- In April, Major Yuri Gagarin became the first human in space. He completed the single earth orbit in eighty-nine minutes. Within weeks the Americans had their own man in space — setting the pattern for the next decade's space race.

## 1962



- The launching of the Telstar satellite brought live Trans-atlantic television to millions of homes. The shrinking world and the shrinking Universe — these were the themes of the sixties.
- Ireland's National Television Station, *Telefis Eireann*, is officially opened.
- First directory published by Irish Plumbing and Contractor. New Wavin factory opens.

## 1963

- Cartoons introduced to Irish Plumbing and Heating Contractor. Potez opens £1m factory in Galway.
- Just five months before his assassination, President Kennedy paid a historic visit to Ireland during a 10-day trip around Europe. The President received a rapturous welcome throughout the country.



## 1964

- Britain imposes levy of 15% on imports from Ireland.
- Title change to Irish Plumbing and Heating Engineer. Dublin Gas Co. opens Home Heat showrooms. Irish Heating Centre also opens.



- Muhammad Ali became what he'd said he was all along — the greatest. Beating Sonny Liston, Ali assumed the title of Heavyweight Champion of the world. This was also a

good year for four other entertainers — the Beatles, who broke music industry records and teenage hearts around the world.



## 1965

- In Belfast the first ever meeting between the Prime Ministers of Northern Ireland and the Republic took place.
- Long running series Talking Shop by Bob Couchman starts. IHVE inaugural Republic of Ireland meeting.



**1966**

- The worst floods in Italian history affected one third of the country's area. In Venice (above) St. Mark's square was submerged.



- Nelson's Pillar blown up. Jack Lynch becomes Taoiseach.

- New cover design for Irish Heating and Plumbing Engineer. Gerry Murphy appointed Editorial Director. Barlo Radiators launched. Northern Ireland Branch IHVE formed.

**1967**

- Irish Plumbing and Heating Engineer moves from Dame Street to Hawkins St. premises. Unidare shows new wallflame boiler.
- Donogh O'Malley's free post-primary education scheme.



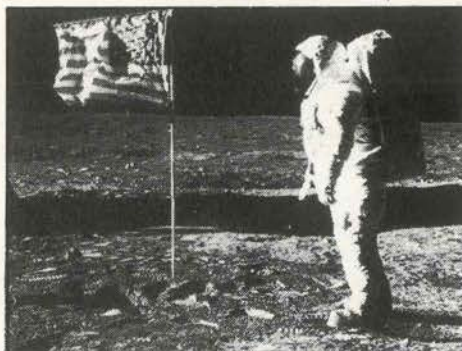
- At an age when many men take to gardening, Francis Chichester at sixty-five sailed around the world single-handed, in Gipsy Moth IV.

**1968**

- Monsell & Mitchell & Co. Ltd. celebrate their 100th year in business. IDHE branches formed in Ireland.
- Unrest in Northern Ireland.
- In an echo of their actions in Hungary in '56, the Warsaw Pact countries invaded Czechoslovakia, "to forestall a counter revolution". It marked the end of Czechoslovakia's cautious experiment with democracy.

**1969**

- IDHE move to ill-fated Merrion Sq. premises. First Dublin Heating & Ventilating exhibition in the RDS. Scanglo International set up factory in Newcastle West. 10,000th Clyde burner installed in the Republic.
- It was a 'giant leap for mankind' and a triumph of modern technology. Buzz Aldrin and Neil Armstrong took their first faltering steps on the moon's surface.
- Fianna Fail win General Election under Jack Lynch.



**1970**



- One of the world's great statesmen, General Charles De Gaulle, died in France. His career for thirty years from 1940 until his death was to a large extent the history of France for the period.
- Two Government Ministers dismissed.
- Scanglo International commence manufacture of radiator valves in Ireland. P. J. Matthews opens Limerick Branch.

**1971**



- While attending the Commonwealth Conference in Singapore, President Obote of Uganda was overthrown by Major-General Idi Amin. Thus began eight years of terror for many of Uganda's citizens.

- Domestic Heating Council formed. Baxendales Ltd. close down. Irish Plumbing and Heating Engineer 10 years publishing. McWhinge file opened in Irish Plumbing and Heating Engineer. Heating Centre transferred to Building Centre.

**1972**



- The Munich Olympic Games was struck by tragedy when eleven Israeli athletes were murdered by members of the Black September group.

- Stormont Parliament is suspended indefinitely.

- British Embassy next door to Irish Plumbing and Heating Engineer burned down, Irish Plumbing and Heating Engineer badly damaged. IDHE course set up in Dublin. Ergas pump LPG ashore at Arklow. IDHE first dinner in Dublin. Unidare launch Jetmatic.

**1973**

- On January first, Ireland entered the EEC along with UK and Denmark.

- Coalition Government comes to power.

- Irish Plumbing and Heating Engineer take over Zone and the title becomes Irish H&V News. Arab oil crisis hits H&V trade.

**1974**

- Irish H&V News move to Blackrock, Co. Dublin, from Merrion Sq. premises. Swing to solid fuel heating starts.

- After months of innuendo and investigation, Nixon resigned his Presidency. In danger of being the first US president to be impeached as his role in the Watergate scandal became clearer, Nixon left the White House to live in the seclusion of his home in California.

- Oil crisis causes widespread alarm.

**1975**



- The man who ruled Spain with an Iron hand, General Franco, died, to be replaced by Juan Carlos, his hand-picked successor. The new king instituted a regime of constitutional democracy for the fast-growing country.

- Death of Eamonn De Valera.

- IHVEX Exhibition organised in conjunction with Irish H&V News. Shell and BP split. Solar energy seminar in Dublin. VMRA move to Tramway House.

**1976**

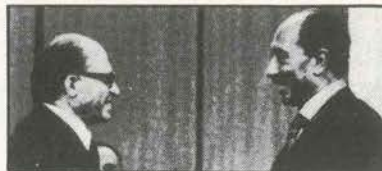
- Draft Building Regulations introduced. Energy conservation in Ireland 1975-85 report issued. Kinsale gas pipeline contract awarded. Golden Jubilee of Institute of Fuel. IHVE becomes CIBS.



- The Anglo-French Concorde has its first commercial flight. The world's first civilian supersonic airliner, Concorde can cruise at around 1400mph.

## 1977

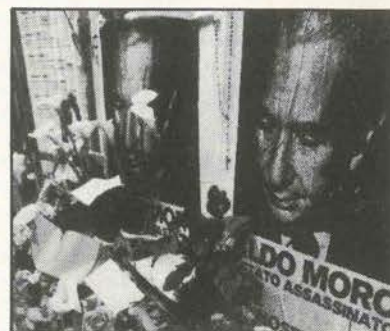
- General Election Victory for Fianna Fail.
- Second IHVEX in RDS. Large scale lay-offs in contracting business. Flo Gas Ltd. formed in Drogheda. Northern Ireland Branch CIBS visit Malta. Victor Gibson, present Advertising Manager joins Irish H&V News. Back boiler warning gets national coverage.



- In a historic and courageous visit, President Sadat of Egypt flew to Israel to be received by Prime Minister Begin. The journey marked the start of a tortuous peace-making process that still continues.

## 1978

- Irish H&V News change logo and has many new layout changes. £4m U.C.C. contract awarded also new Geological Survey Office gets the go ahead. Irish H&V News hit by local postal dispute. Copper pipe on 15 week delivery. Master Air Co. Ltd. set up to manufacture AHU's.
- After two months of anguish and tension, the body of Signor Aldo Moro was found in a car in the centre of Rome. Signor Moro was one of the most prominent political figures in Italy.
- John Tracey wins world cross-country championship for first time in Scotland.



## 1979

- Ireland joins E.M.S. . . . Eamonn Coghlan breaks world record for indocr mile . . . Pope visits Ireland . . . we look forward to the future with confidence.
- Big freeze up — who pays? The Law & Building Services design series started. IHVEX staged in Simmonscourt Pavilion, RDS. No new business says oil companies. Oil panic continues. Back boiler grants introduced. Heat & Power Show in Belfast becomes Heatair. Monthly directory started in Irish H&V News. Ray Loughran present Editor Irish H&V News appointed.



- A staunch supporter of the West and a leader of a country that supplies much of the world's oil, the Shah of Iran, succumbs to mounting internal disorder and leaves his country. An Islamic Republic is declared, with its unofficial leader the Ayatollah Khomeini.

## 1980

- Moscow Olympic Games upset by bans on athletes. Search for oil off Antrim coast. Dublin smoke increases. Death of Savell O Hicks. Finance for Sub-Contractors series started. John Lennon of Beatles fame shot dead in New York. Energy Managers organise. Change in logo and title now H&V News, Irelands Building Services Magazine.



- Dick Hooper wins inaugural RTE Radio 2 Dublin City Marathon

## 1981

- Assassination attempt on Pope John Paul II in the Vatican, Rome. Dublin-Kinsale gas pipeline gets the go ahead. Multi solid fuel stove design competition results announced. Details of new H&V News sponsored gas show announced. M&E section of Scott Tallon & Walker link up with VMRA. Gas fever strikes Dublin. DL's Energy Report starts in H&V News. U.N. conference on LPG.

## 1982

- Minister slams inefficient open fires. Falkland Islands crisis for Britain and Argentina. Another tough year for plumbing predicted. "8,000 can't go to the bathroom" — Tony Gregory T.D. Energy costs in Ireland outstrips Europe. Gas Ireland Exhibition a sellout. 1982 H&V News Directory published.



- HMS Fearless leaves Portsmouth to join the Falkland "armada".

# NATURAL GAS DEVELOPMENT

**Martin P. Derby, managing director of Gastech Ltd. reviews the progress of the natural gas project and points to some of the needs necessary to greater success.**

The importance of planned approach to natural gas development has been commendably evident in the policy adopted by the Department of Energy. Allocation of natural gas to the ESB in the first instance was a pre-requisite to a successful and economic programme of events which will follow in coming months and years.

In the short term, and leaving aside the efficiency factor, a better pay-back is being achieved to the investment in the Cork/Dublin pipeline project. However, some disappointment surrounds a lack of initiative in the area of customer orientation to the scheme. If consumer acceptance into the use of this highly efficient and flexible fuel at an energy-related price is to result, much more direct public relations activity by Bord Gais and other authorities will be necessary. This will be particularly so in Dublin and Cork.

The sooner this is embarked upon, the greater appreciation and understanding there will be of the valuable role this fuel will play in the energy needs of the whole country.

A carefully planned and executed promotional campaign to highlight the benefits of natural gas is essential to the successful application and use of this important indigenous resource.

It is vital also that certain fundamental difficulties which are presently apparent in the pipeline project should be grappled with. These concern the roles of consultants to the industry, the Department of Energy and others, and they must be resolved quickly if efficient and orderly progress is to be made. If not, chaos and disaster will prevail throughout.

The problem stems from two distinct forms of reasoning. On the one hand it is believed that reforming to suit existing appliances is the better way, while others are convinced that full conversion of equipment to suit the new fuel supply is the course which ought to be taken in the first instance.

The latter is the view which I would take since further processing of natural gas can only result in higher unit costs fuel to the consumer in the long term. It therefore follows, it is more cost effective to use the prime energy source directly.

Reforming is the short term answer, but full conversion must be the ultimate objective of the whole scheme. While capital considerations, particularly in Dublin, are a big factor, nevertheless full conversion will prove the more economical and efficient in the long run.

From the consumer point of view the crucial question is when will the gas utilities reduce their prices for gas. Cork has had natural gas for quite some time, and have been reforming, but the planned conversion has not, yet taken place, nor has there been a drop in prices. This should have

occurred by now if it is hoped to achieve customer credibility in the gas undertakings.

Given the required commitment from the Government and the gas utility bodies, natural gas development as a major part of our national energy resources will become a worthwhile reality. But if sectional interests predominate over the principle goal of giving consumers fuel at the right price and the right time, the whole programme will be delayed to the detriment of all concerned.

The policy of the Government is to give priority to indigenous activities in natural gas development, but it is important to recognise the specialised nature of this industry. As things stand many of the concerns who are not gas utilities lack the high degree of expertise essential in this field.

Our company is fortunate that it has been servicing the needs of the LPG industry for many years with a variety of control systems and products. This new challenge will afford us a further opportunity to utilise the technology gained.

The present proposal for service to the Dublin area allows for a Ring Main located around the city suburbs operated from a single city gate station. This will be fed from the transmission main from

Kinsale. The supply pressure at the city gate will be approximately 350 p.s.i.g. and the distribution via the Ring Main effected at up to 70 p.s.i.g.

To provide the necessary pressure regulation and safety protection for this distribution, a pressure reduction module is normally utilised. This unit can typically employ a twin stream of 'active' and monitor governor regulators with pressure sensors to shut off load stream in the event of governor failure. Alternatively a governor and slam-shut arrangement can be employed.

A typical set is shown in Fig. 1.

To complement the Ring Main servicing newly connected and this will be serviced with low pressure natural gas.

As natural gas is 'dry' existing jointing arrangements for pipework and fittings, glands and valves and diaphragms in meters will require either replacement or protection. The protection is necessary to prevent the drying out of the materials used in the above circumstances. This does not occur under the action of Towns gas which is wet. This is an important feature as problems with sealage of the distribution system, notably leakage, can occur with explosive hazards.

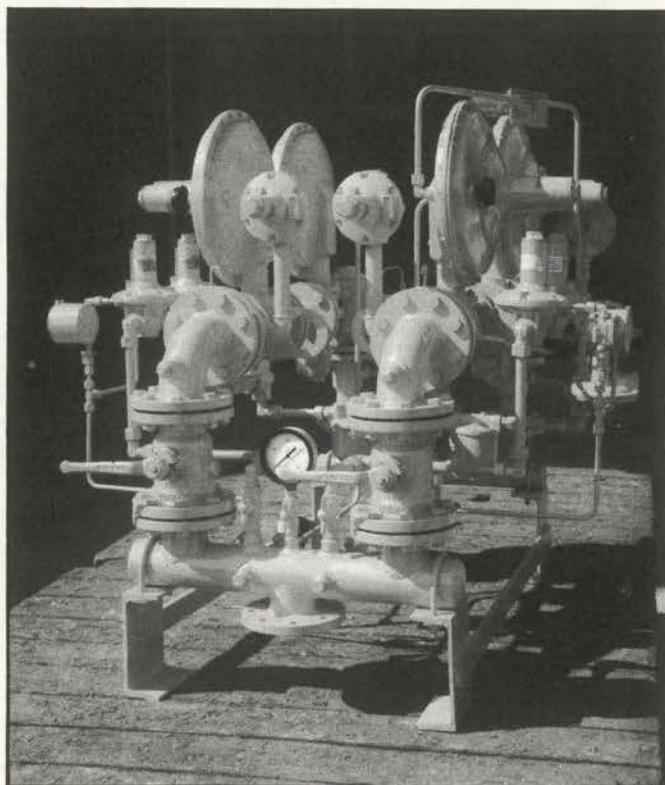


Fig. 1

As natural gas is distributed over more extensive transmission lines of many miles in length, load build-up normally requires consideration of compression equipment for line packing to accommodate an increase in loads, thus obviating the need for additional transmission lines.

In the initial stages of the natural gas development the ESB will utilise this fuel to generate electricity in the Poolbeg and North Wall power stations. This is a logical approach since the distribution system for electrical energy is already in situ.

However, gas is a particularly flexible fuel as it has minimum contaminants and can be burned with a very low level of undesirable products of combustion. Its use to generate electrical power is, therefore, in the long term wasteful of a high quality energy source which it is expected will be utilised directly for energy requirements industrially, commercially and for domestic needs.

The change-over from town gas to natural gas in the major cities in Ireland requires phased sectorisation. This will necessitate a fully programmed approach to rationalise the change over operation.

The various gas companies will need to provide facilities for conversion to maximise the financial benefits which will accrue from the new feedstock in the most cost-effective way.

It is fundamental to the conversion programme that conversion be synchronised with a vigorous marketing policy planned to achieve rapid expansion and development of the cooking, space heating, water heating, commercial and industrial application loads.

A customer orientated information service will be of paramount importance and full use should be made of all successful communication and promotional media. In this area computers will serve well for control operation at administrative level.

There will be a notable requirement for all parties concerned with the successful development of natural gas to establish a stable industrial relations policy to meet the especial characteristics of this new industry. Very much will depend upon this aspect of the programme.

Contractors to the natural gas development project should be required to meet highest criteria of ability to fulfil undertakings and to motivate workforces. There will be job opportunities for semi-skilled personnel but these must be backed by in-job training facilities.

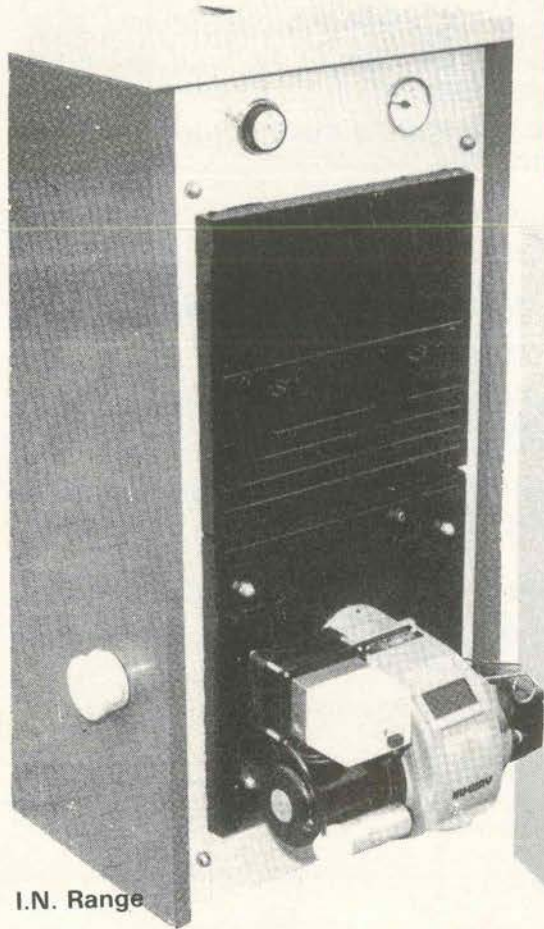
In size and scale the Cork/Dublin pipeline is a major undertaking, but even this will be dwarfed by conversion programmes necessary to bring cities such as Dublin and Cork fully into the advantages of natural gas supplies.

Happily the skills and expertise necessary are not in short supply.

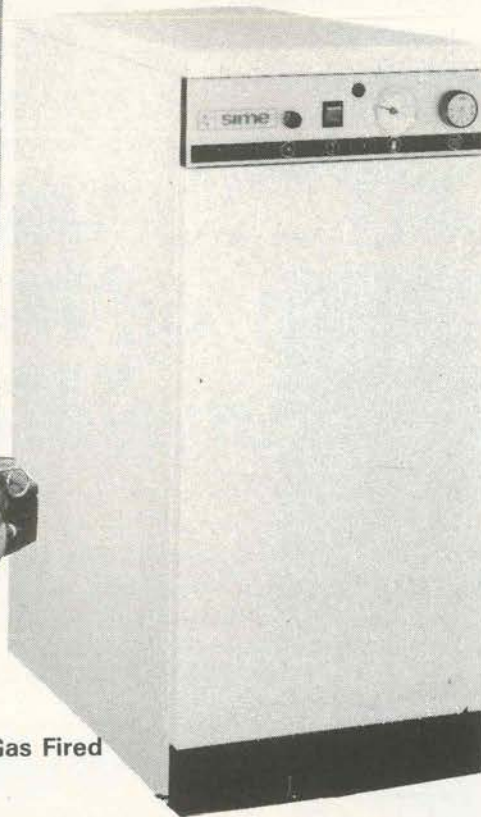


# RIO

**THE MOST SUCCESSFUL  
CAST IRON  
BOILER IN IRELAND**



I.N. Range



Gas Fired

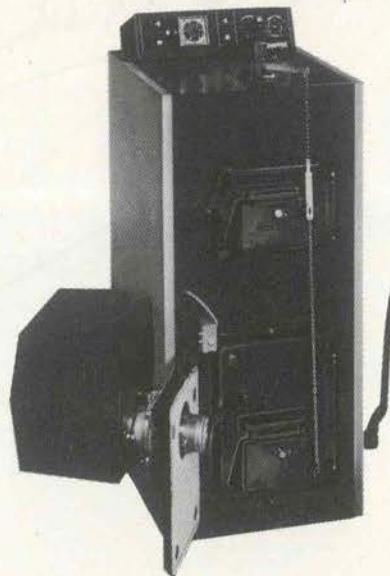
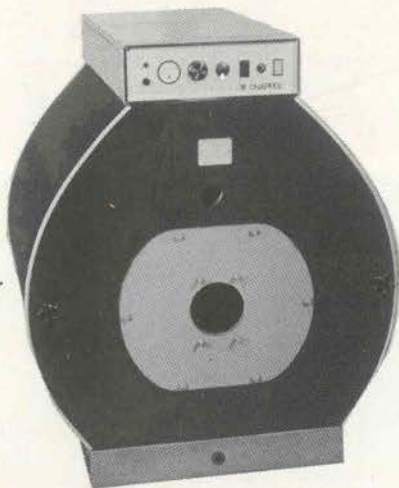
**OIL OR  
GAS  
FIRED  
LPG OR  
NATURAL  
GAS**

Oil or Gas Fired.  
Outputs from 60,000 btu/h to 604,000 btu/h

- Economical
- Reliable
- Corrosion-proof
- Efficient
- Easy Maintenance and Cleaning
- Elegant
- Long-lasting

# CHAPPÉE BOILERS

Highly efficient and compact, Chapée cast-iron sectional oil or gas fired boilers cover a range from 600,000 to 4.4 million Btu/hr (176 KW - 1.29 MW).



Multi-fuel with oil-gas-solid fuel from 70,000 Btu's/hr to 250,000 Btu's/hr.



**HEVAC LIMITED, LISTER COMPLEX, BALLYMOUNT ROAD, CLONDALKIN, CO. DUBLIN.  
TELEPHONE: 519411 TELEX: 30324 TUBE EI**

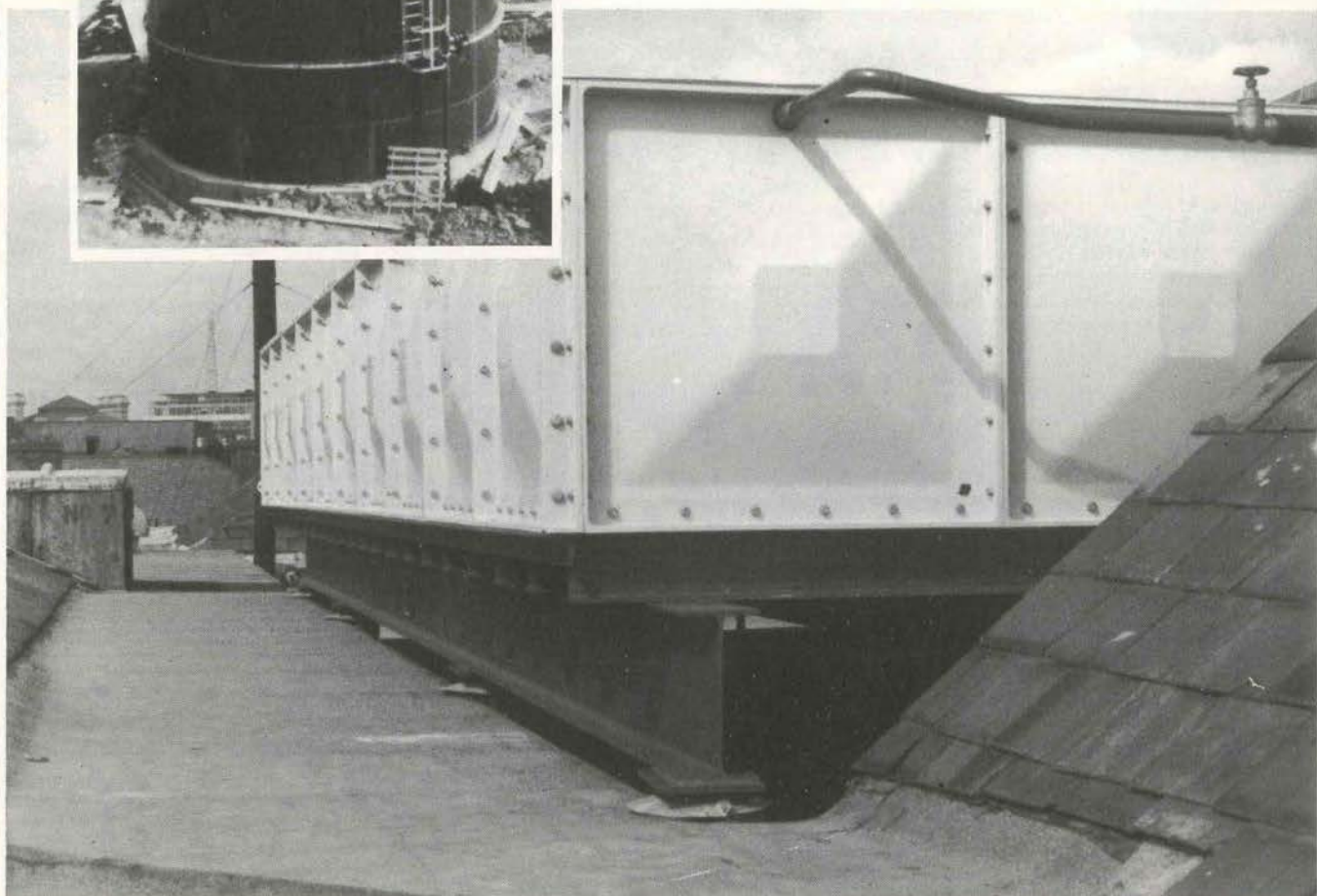
## EURENCO G.R.P. LIQUID STORAGE TANKS

- *Strong, dependable and durable*
- *Easily transported*
- *Easily erected in tank room and outside*
- *Conforms with high aesthetic demands*
- *Adaptable to various requirements*
- *Metric modular design*



## EURENCO/GALGLASS GLASS COATED AND GALVANISED LIQUID STORAGE TANKS

- *The answer to bulk liquid storage problems*
- *Capacities ranging from 13m<sup>3</sup> to 700m<sup>3</sup>*
- *84 different diameter/height combinations*
- *Can be dismantled and re-erected with ease*
- *As suitable for potable water as for effluent*
- *Galglass are F.O.C. approved*



# EURENCO

SALES LTD.

106, THE COOMBE, DUBLIN 8. TEL: 755557 TELEX: 74147

Well known trade personality of some years ago, Gerry O'Malley, takes a fond look at the 'seasons' of the Irish Heating Centre and domestic heating trade of that time. Did it all happen or was it just a dream? It must have been true as there are still many around to tell the tales, so here is at least part of the story in Gerry's inimitable style.

## “And Now . . . from the People Who Gave You Hypothermia . . .”

### WINTER

"What freezings have I felt, what dark days seen"

It was the age when: the bath was no longer used for coal storage, the outside *kazi* a thing of the past. The 'parlour' had metamorphosed and become a 'lounge' and its use not confined to bonfire nights and funerals. Turnips and rice pudding had given place to Jerusalem artichokes and kumquats.

The Plain People of Ireland had at last come to grips with Mark Twain's famous beef that "everybody talked about the weather but nobody *did* anything about it". Realisation had finally dawned that it was ridiculous to force oneself into tolerating the intolerable. If the *vin* was to be *chambré*, then the *chambré* had to be. Puritannical to believe that what was unpleasant was necessarily character-forming or that the desire to be comfortable was decadent.

It was the age when we began to heat our houses.

There were, of course, difficulties. At every corner dangers lurked. Four basic 'fuels', each claiming pre-eminence, dozens of ways of using each fuel, contradictory advertising, misleading claims, no Trade Descriptions Act. Installers some of whom knew as much about the theory and practice of heating as your arse knows about

snipe-shooting. Cowboys on every side, to the point where it came as no great surprise to people to learn that one of the most enduring inventions in heating had been the work of a notorious robber and outlaw, Cole Younger.

### SPRING

"Blossom by blossom, the spring began"

1964 saw the foundation of the Irish Heating Centre in Dame Street. The notice board inside the glass doors said, "PUBLIC ADVISORY SERVICE" (and smart-alecs tended to remove the "L").

It was a trade-supported organisation acting on behalf of the entire heating industry (but concentrating on the domestic). Modern marketing and promotional methods were used to foster a general interest in planned heating and to shorten the interval before decision to purchase.

Here are some of the stated activities and aims:

#### (QUOTE)

\*Media manipulation (special features in national and local newspapers and magazines, talks on TV and radio, lectures to trade and public groups (e.g. it introduced microbore to the trade and gave regular lectures to home management advisors working in every county), direct mail to

specialist areas and trades (e.g. pubs and hotels)

\*Analysis of trends

Every single effort in press and public relations increased the turnover for the trade as a whole.

For the consumer it provided an unbiased, impartial advisory service. It was a showcase for manufacturers and their products but was not, simply, a distribution centre for glossy leaflets. The staff consisted of knowledgeable people, technically competent, whose only bias was on the side of the consumer.

The principle in operation was that a satisfactory appliance or installation served the best interests of the industry.

Hardly anybody would dispute the notion that the industry as a whole was highly disorganised. Disorganisation meant excessive expenditure, loss of profits and uncertainty for the future.

With the backing of the entire industry it was hoped the Heating Centre could co-ordinate the efforts of committees working along the following lines:

\*LEGISLATION: Careful investigation of all Government legislation affecting the industry with submissions and briefs to the appropriate department as necessary.

\*MARKETING: Covering aspects of the industry's extensive interest in the marketing function from a national policy for fuel to co-operative sales promotion, public

relations and publicity. Provision for a complete statistical programme for pooled information on the industry's production, sales, market forecasts. This would lead to the kind of control that would eliminate seasonal peaks and valleys.

**\*INDUSTRIAL RELATIONS:** Study of the employer/employee relationship and comprehensive wage rate and fringe benefit surveys; study of labour legislation and investigation of new developments in matters such as workmen's compensation, group insurance and other related plans.

**\*MANAGEMENT TRAINING:** Business management for small contractors.

**\*STANDARDS:** Study of the effects on the entire industry of all Codes and Regulations, Specifications and Approvals.

**\*NEW DEVELOPMENTS:** Issue of trade reviews to the industry giving the "cons" as well as the "pros".

**\*COMMUNICATIONS:** Establishment of the necessary life-line of communications between the different sectors of the industry.

Some of the functions outlined were already being attended to by one or other of the trade associations ploughing their own individual furrows on behalf of their members. The proposed centralisation would simply mean the co-ordination of these valuable administrations with the addition of important functions not being attended to by anybody.

The result would be a more effective presentation of the heating idea, increased sales, greater efficiency, vastly enhanced bargaining power, control leading to all-year-round employment and greater profitability for every reputable member of the trade.

#### (UNQUOTE)

Not exactly shrinking violets, were we? With such grandiose aims, you'd be forgiven for thinking that the Centre was staffed entirely by Jesuits. I just hope we didn't *think* in the terms that this idiotic management-type jargon suggests.

Was the heating industry disorganised? Well, put it like this: have you ever heard Mick Dunne, "The Talking Plank", give a commentary on a football match? Here he is on a match between Down and Offaly: "It's a goal .. no, it's a point ... no, it's wide ... sorry, the umpire has signalled a 45 metre free, but wait, the referee has given a penalty! A penalty to be taken by the ... Offaly No, 1, sorry, the

Down No. 8 ... and that is ... Colm McAleaney ... I mean, Matt Connor".

That was the heating industry in 1964.

## SUMMER

"All the live murmur of a summer's day"

Merry as a marriage bell ... a genuine *esprit de corps* that was due, in part at least, to the small numbers involved. Everybody knew everybody. It was a great time. (Recently I looked down a list of heating contractors in Dublin and was dismayed to find that only a few of the names were known to me. Have all the others made their money and retired to villas in Marbella or have they, like myself, settled for penury and oblivion?)

At the Heating Centre there was a feeling of — dare I say it? — idealism and dedication among the staff. We genuinely felt we were doing a useful job of work. After the doors were closed we had to tackle the postal enquiries. But there was a commitment that made up for the long hours and miserable pay.

Was the Centre really unbiassed? Suggest otherwise to any of the people who worked there (including the distinguished Editor of this paper) ... but be sure to stand well back! It was well known that Shell paid the lion's share of the bills but then oil enjoyed the major share of the market at that time.

Our conversion of quotations sought into contracts placed was about two out of three which was much better than most contractors were doing off their own bat.

The low-ceilinged basement was well on its way to becoming the best drinking place in Dublin, not the least of its attractions being that all the drink was free. However delightful that was — and worthy of being an end in itself — it was only a by-product of the countless meetings, lectures and exhibitions held there.

Manufacturers liked to introduce their wares to the trade in that environment rather than in an hotel. Showing in the company of their competitors was tacit expression of confidence in their products.

Some establishment figures on the industrial side (who always seemed to me to possess qualities that I can only describe as spinsterish) stood like the Pharisees of old and

scorned the new movement. Their chief cavil seemed to be that the activity was "commercial and profit-making" (oh, horrors!) I hope it's some solace for them to know that, not only was there never any profit but it was always a struggle to meet the outgoings.

## AUTUMN

*"Tears, idle tears,  
I know not what they mean  
Tears from the depth  
of some divine despair  
Rise in the heart  
and gather to the eyes  
In looking at  
the happy Autumn fields  
And thinking of the days  
that are no more"*

It was obvious that the public advisory service would outlive its usefulness. We went a considerable way toward organising a Register of Contractors that would give absolute guarantees to the consumer. Advice was sought from the contractors, individually and in committee. They were all in favour. The Rules, Regulations and Registration Forms were at the proof stage. The overly cautious soliciting gentleman employed by the Centre deemed the plan unworkable. And that was that.

A big mistake there. The Registration Scheme would have endured and been a boon to industry and consumer alike. Everything that has happened in consumerism in the intervening fifteen years supports that view.

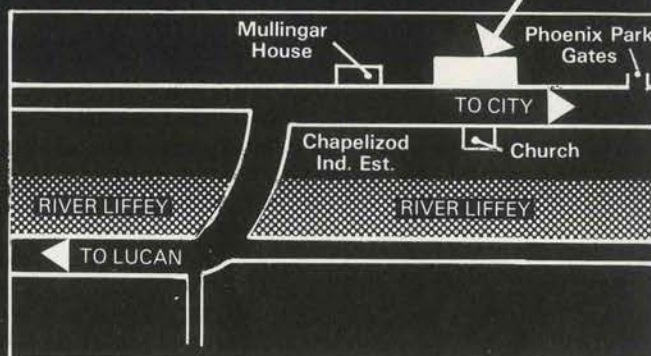
One of the Directors of the Centre once said that the idea of setting up the service had come to him when he was thinking about putting in central heating in his own house and found it impossible to get impartial advice. I spent six years of my life under the misapprehension that he and his colleagues were motivated by altruism when they founded the Centre. I say that knowing that the admission will provoke nothing but ribald laughter. It happens to be true all the same. When I discovered that the impetiginous creeps were only sitting out the years on a cheaply-acquired lease listening to that sweetest of sounds ... the hum of property appreciating ... I felt a profound sense of let-down. It was the end. We were back with Winter again.

# QUADRANT Engineers Ltd.

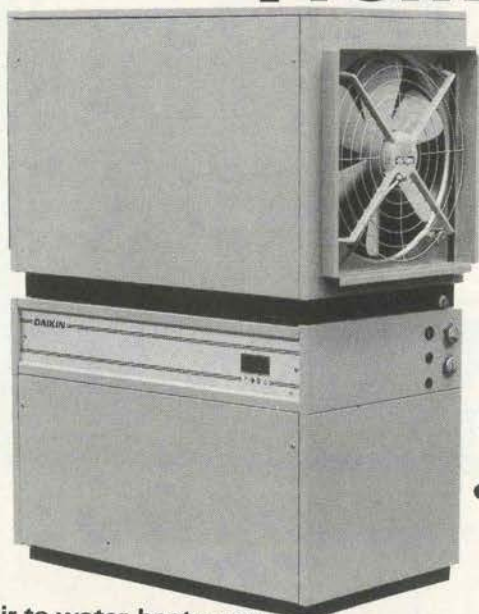
## HAVE NOW MOVED TO CHAPELIZOD DUBLIN 20

Tel: 265711/265712/265713

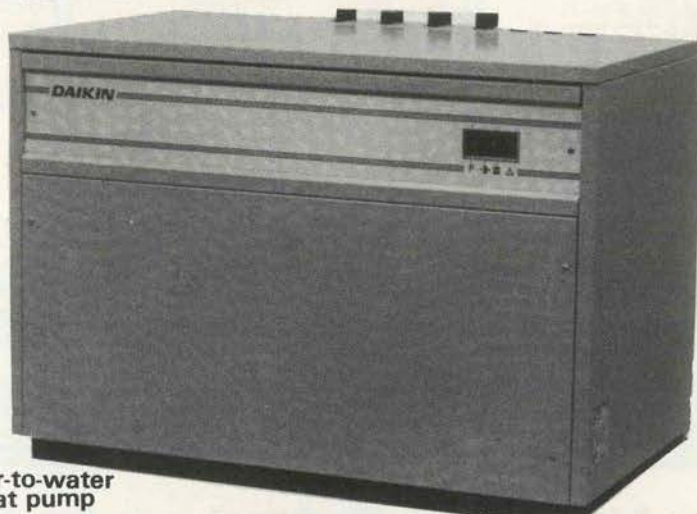
Formerly Smiths Garage



## New Small Heat Pump Range From **DAIKIN**



● Air-to-water heat pump



● Water-to-water heat pump

**AVAILABLE IN SIX SIZES WITH SMALLER SIZES  
AVAILABLE FOR SINGLE PHASE ELECTRICITY  
SUPPLY.**

# Coolair

AIR CONDITIONING / AIR DISTRIBUTION



25, Cookstown Estate, Tallaght, Co. Dublin. Tel: 511244/511540. Telex: 31689 ● Mallow Road, Cork. Tel: (021) 503630.



# Euro Pumps



COOLEEN, LABURNUM LAWN, CORK.

TEL: (021) 43822.

Agents and Distributors for

## EURAMO PUMPS

**MX130A  
MX180A**

Glandless variable output domestic circulators. Heads to 4.2 m (14 ft). Capacities to 3.5 m<sup>3</sup>/hr (13 gpm).



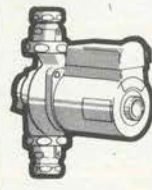
**1030-1040**

Glandless variable output circulators for medium size heating systems. Heads to 7.5 m (25 ft). Capacities to 10 m<sup>3</sup>/hr (37 gpm).



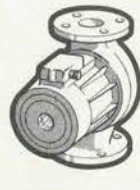
**300-OC**

Brass variable output glandless circulator for hot water services. Heads to 3 m (10 ft). Capacities to 2.5 m<sup>3</sup>/hr (9 gpm).



**C.1000**

In line glandless variable output circulators. Heads to 20 m (66 ft). Capacities to 100 m<sup>3</sup>/hr (396 gpm).



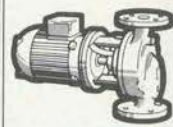
**C.2000**

In line glandless variable output twin circulators. Heads to 20 m (66 ft). Capacities to 120 m<sup>3</sup>/hr (440 gpm).



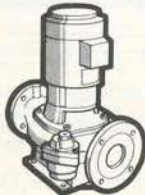
**GIM-NEC-GET**

Close coupled glandless in line pumps. Heads to 20 m (66 ft). Capacities to 65 m<sup>3</sup>/hr (248 gpm).



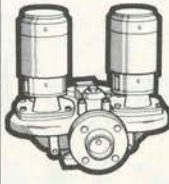
**LS/LR.1000**

Vertical in line variable output glandless pumps. Heads to 30 m (99 ft). Capacities to 350 m<sup>3</sup>/hr (1,260 gpm).



**JS/JR.2000**

Vertical in line variable output glandless twin pumps. Heads to 30 m (99 ft). Capacities to 700 m<sup>3</sup>/hr (2,560 gpm).



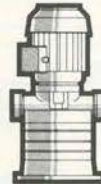
**PM-GM**

Close coupled centrifugal for general pumping duties. Heads to 40 m (133 ft). Capacities to 200 m<sup>3</sup>/hr (734 gpm).



**MA.2000**

Vertical multistage centrifugal self-priming pumps. Heads to 60 m (197 ft). Capacities to 4 m<sup>3</sup>/hr (15 gpm).



**ME.2000**

Vertical multistage centrifugal pumps. Heads to 100 m (330 ft). Capacities to 8 m<sup>3</sup>/hr (30 gpm).



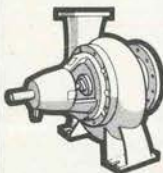
**MV.2000**

Vertical multistage centrifugal pumps. Heads to 270 m (886 ft). Capacities to 22 m<sup>3</sup>/hr (80 gpm).



**NF E 44111**

Standardised centrifugal pumps to DIN 24256. Heads to 90 m (295 ft). Capacities to 1,800 m<sup>3</sup>/hr (6,500 gpm).



**GV.27-GV.50**

Vertical free standing sump pumps. Heads to 25 m (115 ft). Capacities to 30 m<sup>3</sup>/hr (110 gpm).



**U.6100**

Submersible sump pumps, manual and automatic operation. Heads to 25 m (115 ft). Capacities to 30 m<sup>3</sup>/hr (110 gpm).



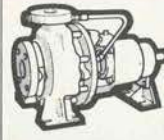
**U.6200**

Submersible pump, manual or automatic operation. Heads to 40 m (132 ft). Capacities to 200 m<sup>3</sup>/hr (732 gpm).



**NF E 44121  
NC-NI-NO**

Standardised centrifugal pumps for chemicals and other liquids. To DIN 24256 & ISO 2808. Heads to 150 m (495 ft). Capacities to 1,800 m<sup>3</sup>/hr (6,500 gpm).



**PV.1000**

Direct coupled vertical centrifugal units for industrial applications. Heads to 140 m (462 ft). Capacities to 800 m<sup>3</sup>/hr (2,930 gpm).



**"This is just the tip of the iceberg, ask for details of our full range of Domestic and Industrial pumps"**

**Distributors & Stockists for the Industrial Range of Euramo Pumps**

# FINHEAT LIMITED

17 Usher's Island, Dublin 8. Tel: 778109/778120/728431 Telex: 30751

# Switching to Coal at Mitchelstown Co-Op

by A. O'Grady

At the IIRS seminar on switching to coal earlier this year Arthur O'Grady of Mitchelstown Co-Op discussed the conversion of their existing heating system to, at least in part, coal. The following is the text of that discussion.

## Introduction

The relative price advantage of coal over fuel oil, as a heat source for industrial purposes, assumed very significant proportions in this country over the past one to two years. It also appeared that coal would be more than competitive with natural gas as a heat source for larger industry when that fuel became available in this country.

For these reasons mainly, and as a

result of having seen other industrial coal burning installations, Mitchelstown Co-operative considered that there appeared to be a very strong case for substituting coal for some of the oil used for fuelling its boilers, at the earliest opportunity. The existing boiler plant at the organisation's various locations consisted entirely of shell type boilers ranging in output from 3 MW to 13 MW and the majority of these boilers were fitted

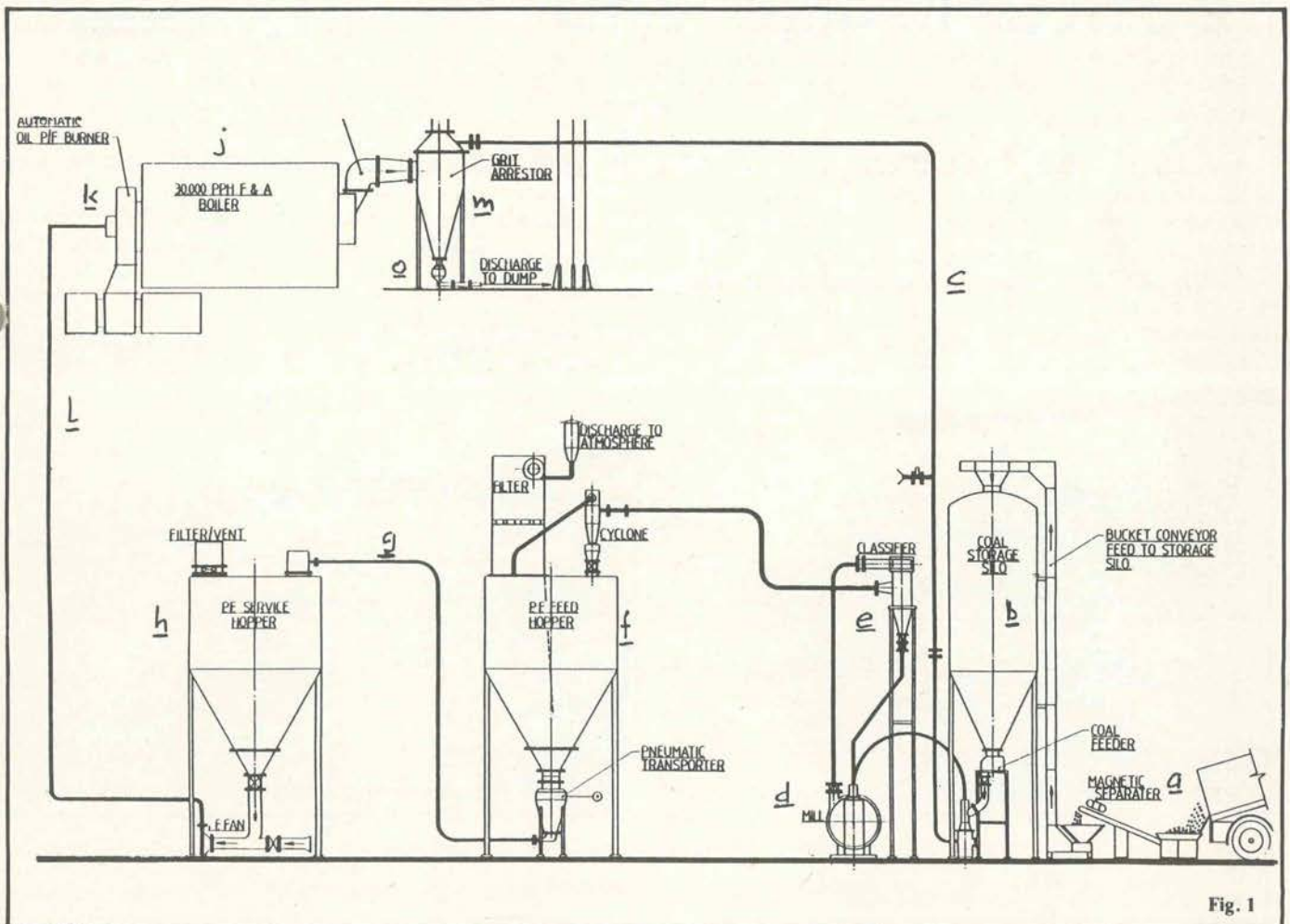
with rotary cup burners.

Two broad options were looked at in detail during the Winter of 1980/81 in regard to coal burning:-

a) that of installing new coal burning boiler equipment, and

b) that of modifying existing boiler plant to suit coal burning.

A number of different systems in each category were investigated. The outcome of this study was that we



**PROJECT PROFILE: CONVERSION OF EXISTING PLANT AT MITCHELSTOWN CO-OP**

should proceed, with conversion to coal on a phased basis, and initially instal one substantial coal burning unit at the organisation's milk powder complex in Mitchelstown.

It was considered that this coal burning installation would comply with the following main criteria:-

- a) Have a pay-back of not more than two years;
- b) Be compatible with the existing steam raising facilities and steam load pattern at the site;
- c) Have environmental compatibility with food factory and local requirements;
- d) Be capable of using either "screenings" arising from the domestic coal market or specially imported "smalls" as required;
- e) Not present any major operational problems for the existing boiler operators.

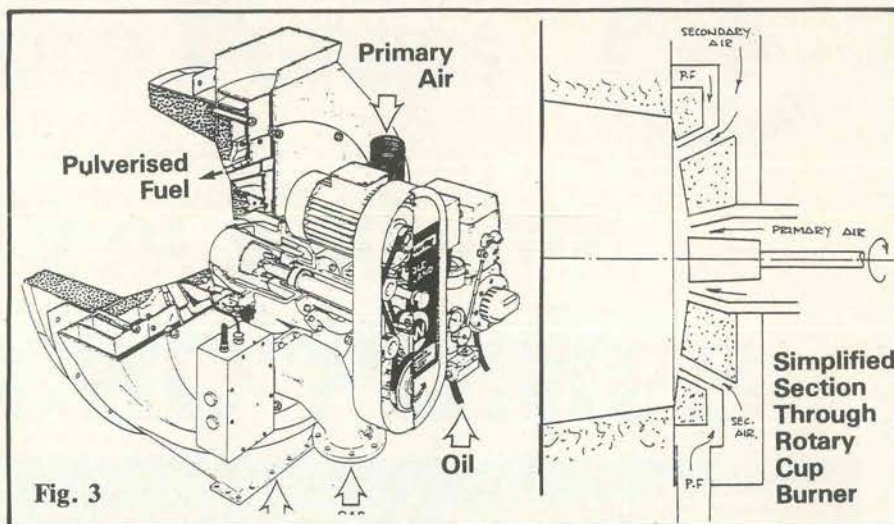
**Outline of System**

The system it was decided to instal was based on the AW type burner supplied by the U.K. company, Hamworthy Engineering. The company had just previously developed a modified version of this oil/gas dual firing rotary cup type burner. The burner was mounted on an existing boiler in the milk powder complex.

The modifications developed by Hamworthy made it possible to burn pulverised coal in combination with either a pilot gas or oil flame.

The overall installation can best be considered under five headings:

- 1) Raw coal delivery and storage
- 2) Coal pulverising
- 3) The boiler and firing system
- 4) Grit collection and ash handling
- 5) Control systems for the above.



**Fig. 3**

An almost total "packaged" contractual arrangement was agreed with the Hamworthy company for the overall system. Due allowance was made in the contract for the fact that the system had been newly developed and that no proven commercial installation was in operation at the time.

The particular boiler used was selected because it was housed separately in its own room in the boiler house involved. There was also adequate outdoor free space beside it for the location of external equipment.

Commissioning of the system began in July 1981.

**System Arrangement**

The main components of the system, and which are shown schematically on Fig. 1 and in Plan Outline on Fig. 2, are:-

- a) A coal reception facility;
- b) A coal storage silo;
- c) A hot gas duct from the flue to the

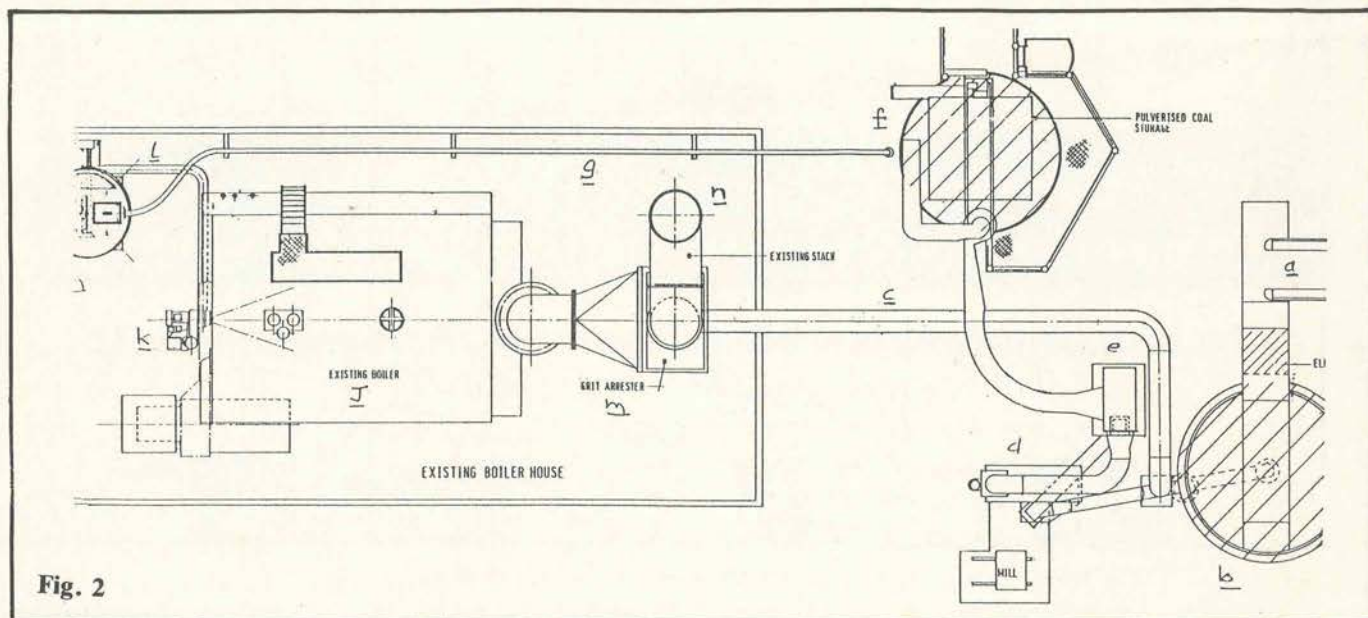
- pulveriser;
- d) A coal pulveriser;
- e) A pulverised coal classifier;
- f) A pulverised coal feed hopper;
- g) A pulverised coal pneumatic conveyor;
- h) A pulverised coal service hopper;
- j) The already existing boiler;
- k) A multi fuel burner;
- l) A pulverised coal pneumatic feed pipe;
- m) A grit arrester;
- n) The already existing chimney;
- o) An ash pneumatic conveyor.

The various control and monitoring panels are not shown on this diagram.

**Plant Description**

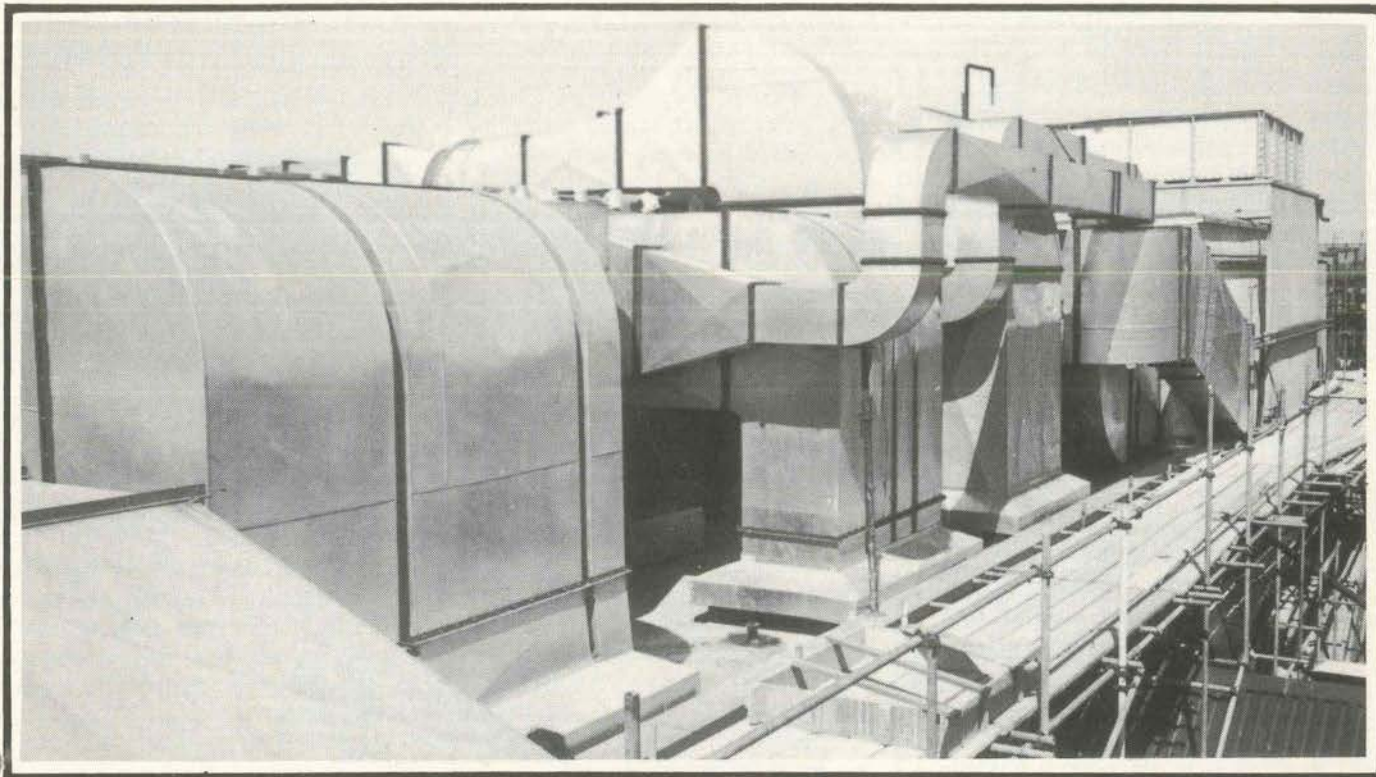
**1. Raw Coal Delivery and Storage**

The coal purchased to-date has been 'screenings' arising from the local domestic coal trade in the Cork area. This coal originated mainly from America and Britain but included some of Polish origin at the early stages. It is delivered to site in 10/20

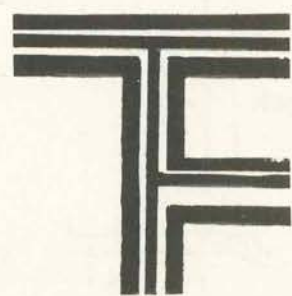


**Fig. 2**





**THE SPECIALISTS IN  
Ductwork, Canopies  
and Spiral Tubes**



*Tru-Flow Limited*

**Sheet Metal Works**



**CROSSBEG INDUSTRIAL EST., BALLYMOUNT ROAD UPPER, DUBLIN 12.  
TEL: 520977/520154/520182/520270/520548**

**PROJECT PROFILE: CONVERSION OF EXISTING PLANT AT MITCHELSTOWN CO-OP**

tonne loads by lorry. The coal is tipped from the lorries into a small reception hopper situated above a moving conveyor belt. Tramp metal is removed automatically at this stage prior to being conveyed into a bucket elevator which elevates the coal some 60 feet into a storage silo. The silo is constructed from steel reinforced polyester and has a storage capacity of 55 tonnes. The support legs of the silo are fitted with strain gauges which indicate the coal weight in the silo.

**2. Coal Pulverising**

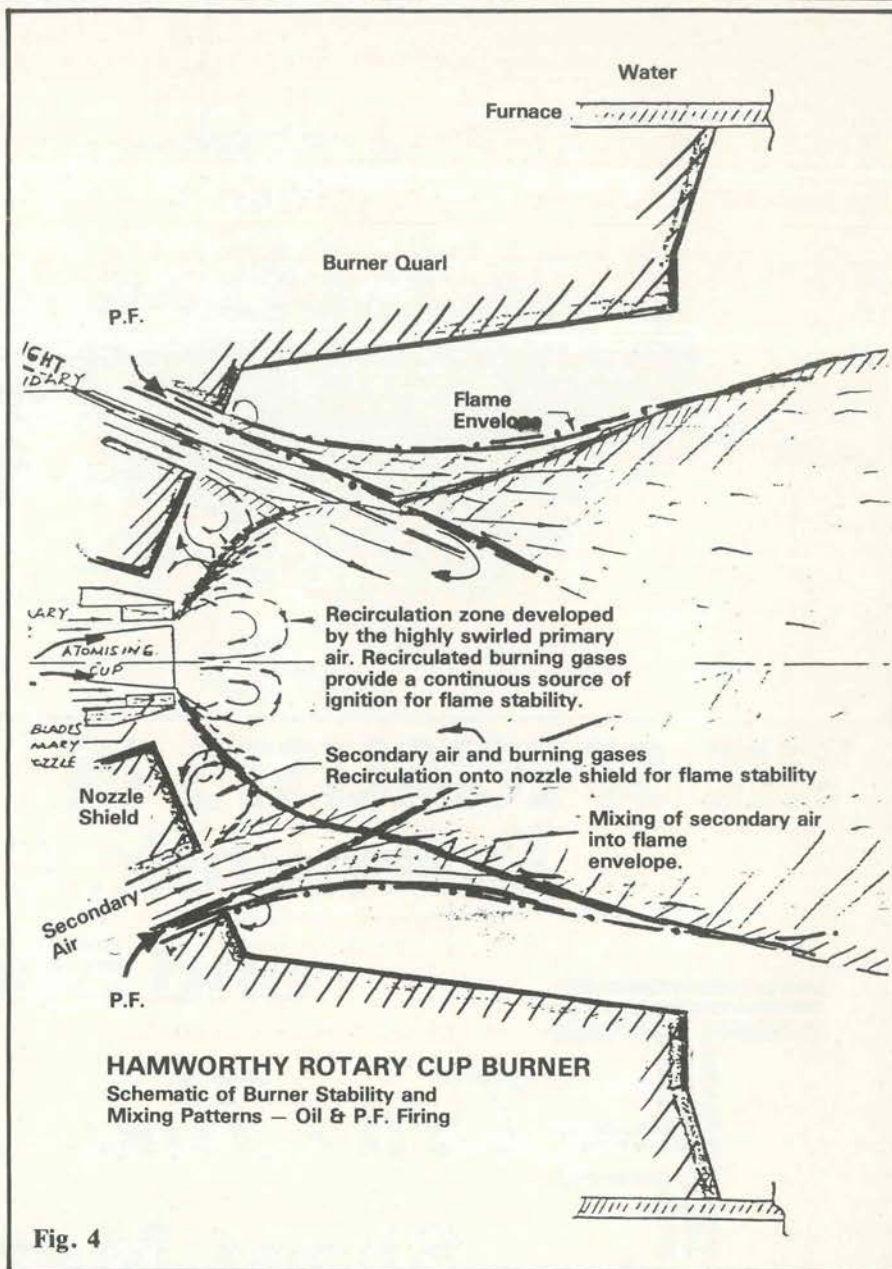
Coal is metered from the storage silo using a table feeder. The coal is then conveyed pneumatically with hot flue gases ducted from the boiler exhaust stack into a pulverising mill. This pin type mill then pulverises the coal to a nominal particle size of 75 microns (80% passing a 200 mesh screen). From the mill the coal is blown into a 5-tonne PF feed hopper having passed through a classifier which returns oversize particles to the mill. From the PF feed hopper the pulverised fuel is pneumatically conveyed, using a dense phase system, to the one tonne PF service hopper which is located in the boiler room close to the boiler.

**3. The Boiler and Firing system**

The boiler involved is a Thermax type Thompson Cochran, size 9 Steam boiler. It was purchased in 1977 for firing with heavy fuel oil and had a rating of 8.7 MW at 250 p.s.i.g. Its total heating surface is 259 sq. metres. The single furnace tube is 3.74 metres long and 1.49 metres in diameter.

Relatively minor modifications to the mounting plate and refractory only of the existing boiler were required to facilitate the fitting of the new burner.

The new burner assembly, as previously indicated, is standard dual fuel Hamworthy AW unit with the addition of a secondary air register arranged to effect introduction of PF into the combustion zone (Fig. 3). The PF is conveyed to the burner via a lean phase pneumatic system which provides 15% of the M.C.R. secondary air. Modulation is effected by varying the quantity of P.F. metered into this air stream by a variable speed rotary valve. Oil is fed into the rotary cup in the conventional manner at a fixed rate of 20% of the M.C.R. oil requirement. Natural gas could be substituted for this oil input



**Fig. 4**

with minimal modification.

The configuration of the fuel mixing and flame ignition in the combustion zone is indicated in Fig. 4.

A Clyde automatic sootblowing system, consisting of two single rotating nozzle design blowers, was fitted in December 1981 in the first reversal chamber. The fitting of these two units necessitated the installation of two shroud pipes through the wet back of the boiler.

**4. Grit Collection and Ash Handling**

After combustion has taken place in the furnace tube of the boiler the exhaust gases move through the boiler via the second and third pass and enter a multi-stage cyclone grit arrestor and from there to the previously existing chimney. The ash is collected in this grit arrestor and then conveyed

some 50 metres into a collection disposal container by means of a dense phase pneumatic conveying system.

**5. Control Systems**

Boiler control for oil burning is fully automatic in the conventional Hamworthy manner. Control for dual fire firing is also fully automatic which is effected by the parallel operation of a PF modulation system (Fig. 5).

An oxygen trim system operates automatically for all modes of firing and records O<sub>2</sub> level continuously.

Monitoring facilities are also fitted to measure the various conditions throughout the boiler, including temperatures and pressures as well as fuel and power usage and steam output.

Control of the coal pulverising system is also fully automatic. This is related to coal feed, and the outlet

**PROJECT PROFILE: CONVERSION OF EXISTING PLANT AT MITCHELSTOWN CO-OP**

temperature of the pulveriser. A mimic panel identifies any fault arising within the pulverising system.

**Performance**

Since start-up the system has undergone various tests to prove its performance. A comprehensive survey of all aspects of performance and efficiencies was undertaken by a firm of independent consultants and we expect their report in the near future.

Pending the receipt of this definitive report we would comment as follows:-

*Combustion Efficiency*

When operating with an approximate 75/25 coal/oil ratio at M.C.R., oxygen readings of 4.5% in the exhaust gases and outlet temperatures of

255°C/260°C have been consistently obtained giving combustion efficiencies of the order of 83%. This is slightly lower than when operating the boiler on oil only. We estimate that 2%/3% of combustible material is retained in the ash. This factor can be affected by the preheating of the PF carrier air.

*Output*

We are satisfied that the boiler output when operating on PF is up to the original M.C.R. oil firing specification of this boiler. Also reaction to load demands is no different to normal oil firing behavior.

In the first weeks of operation a number of problems were experienced and remedial action has already been taken in all cases.

*Savings*

On the basis of 80/20 coal/oil combination the system reduces the oil requirement by 800 litres/hr.

We estimate that the boiler which is operating as a base load unit will be in operation for at least 4,500 hours/year. This will produce a reduction in oil usage of 3.6 million litres/year which will be replaced by coal usage.

If one assumes an oil cost of £150/tonne and a coal cost of £75/tonne of oil equivalent the annual fuel cost savings would be of the order of £250,000. With a capital cost of less than £200,000 the project would appear capable of meeting the original criteria by a wide margin.

In conclusion I would say that overall we are satisfied with the project to-date. Nevertheless we have experienced a number of problems. Some of these were normal teething problems, others due to the lack of experience with handling coal and yet others due to system development, as one might have expected.

The degree of success achieved so far on the project reflects the co-operation and diligence accorded to us by the Hamworthy personnel, and the help given by other individuals and organisations.

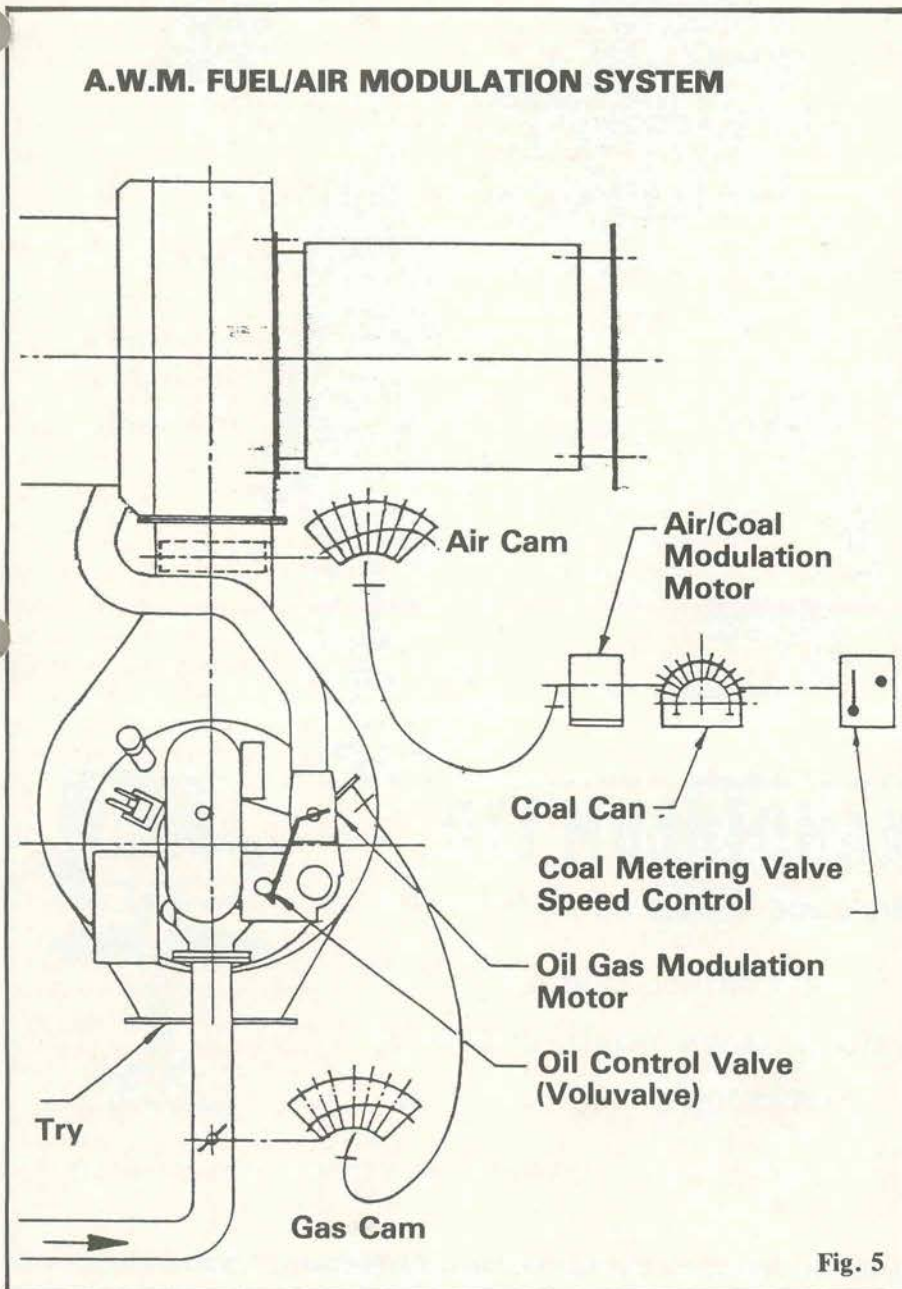


Fig. 5

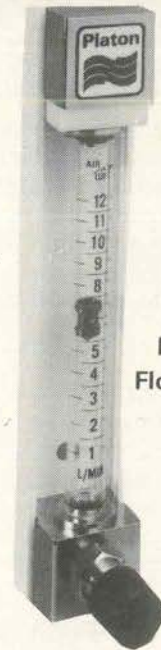
# A Condensed Guide to MANOTHERM activities

## THOMMEN CALIBRATOR EM



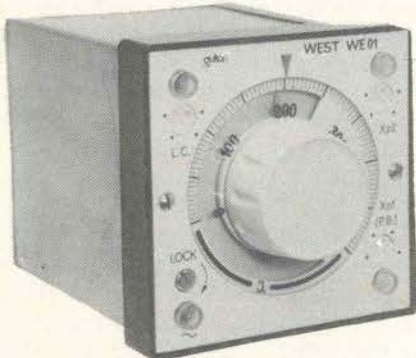
Type EM 421  
410 x 260 x 230 mm  
approx. 8 kg

Indep. from mains Separate power supply 24V D.C.

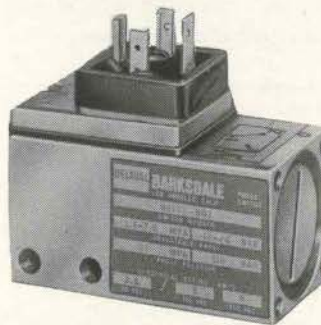


Platon  
Flowmeter.

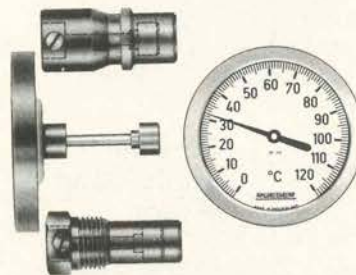
## West WE 01 process controller



96mm square metal case.  
PD+PI control action.  
Limit comparator & controlling  
output option.



Barksdale piston pressure switch  
for pressures up to 315 bar.



Rueger thermometers.



Platon 'M'—valve.  
Air operated miniature  
control valve  
for automatic  
control of  
most media.



Thermocouples &  
resistance  
thermometers

# MANOTHERM LTD.

Controls and Gauges for all industries

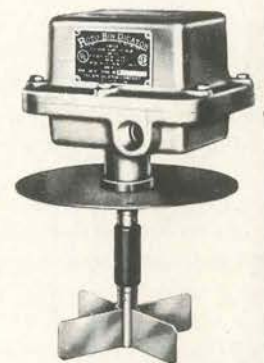
THE CONTROL CENTRES

4 WALKINSTOWN ROAD, DUBLIN 12

Phone: 522355, 522018, 522229. Telex: 24467

10 KNOCKBRACKEN PARK, BELFAST BT6 OHL

Phone 645966



Roto-Bindicator.

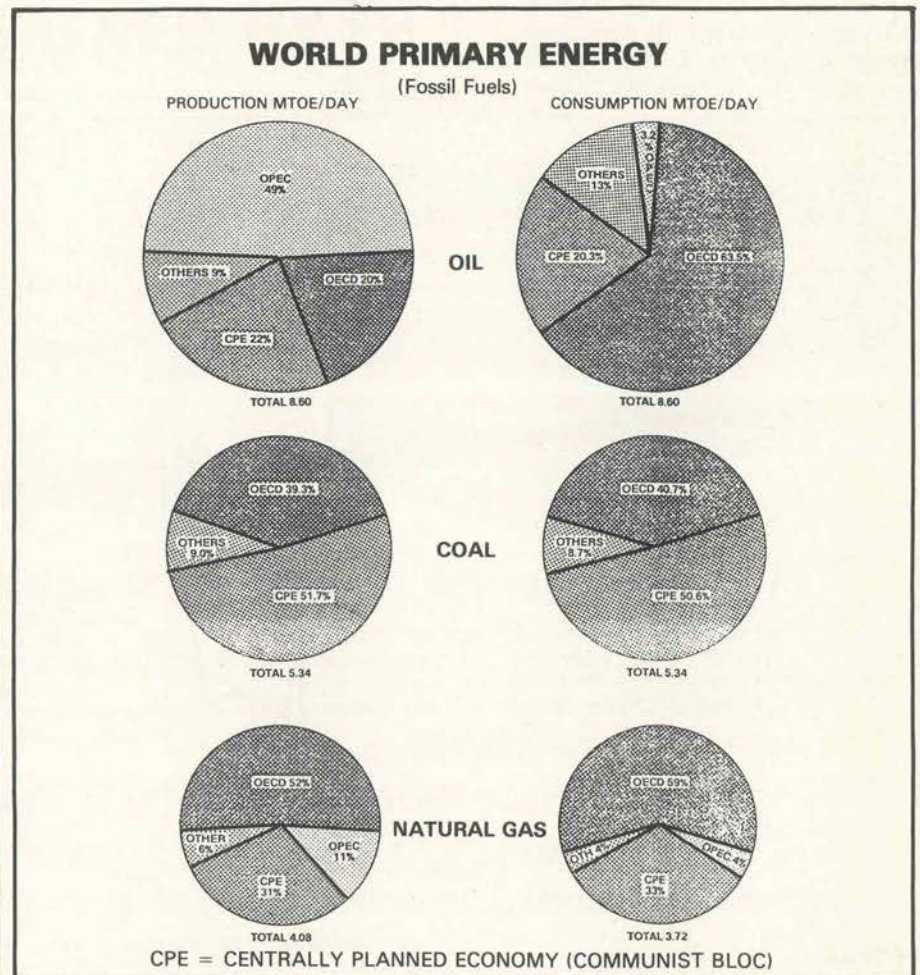


DL'S ENERGY REPORT • DL'S EI  
 REPORT • DL'S ENERGY REPO  
 • DL'S ENERGY REPORT • DI  
 ERGY REPORT • DL'S ENER  
 RT • DL'S ENERGY REPORT  
 DL'S ENERGY REPORT • DL  
 ENERGY REPORT • DL'S E

# Developments in Energy Over the Past 21 Years

This month, the Editor has asked me to give way to venting my anger at our lack of energy policy, and my reviewing of the various fuel providers and utilities. I am reluctant to do so, given the recent drop in price in oil products, the entry of a competitor into CDL market, the State take-over of Whitegate Oil Refinery, the problems arising from an E.S.B. monopoly, the Bord Gas Eireann pricing policy, and the Alliance and Dublin Consumers Gas Company saga. All in all, not the comprehensive energy policy that one can be proud of. However, this month the Editor has asked me to write on the developments in energy over the last twenty-one years to coincide with the anniversary of the magazine.

Taking the World energy situation first, we have during the last twenty-one years found to our cost that there is a relationship between energy demand and economic activity. We have found that energy, on occasions, can be a limiting factor to economic development and that the problem requires to be solved urgently. We have also found that energy is a strategic resource and that while coal and natural gas are largely in balance,



**DL'S ENERGY REPORT**

there is a large imbalance in the oil situation. OECD countries, those largely comprising of the U.S.A., Canada, Australia, Western Europe and Japan, consume 63.5% of World energy, but produce only 20%. On the other hand OPEC produce 49% but consume only 3.2%. Table 1 shows these figures.

We have witnessed during these 21 years a period of instability. This was emphasised in the 1970's which was as far as energy is concerned, was a decade of upheaval. It was a decade when we had problems with regard to both pricing and uncertainty. As the decade progressed we were to realise that there is more at stake than just the Sunday drive in the car. One effect of the OPEC action in 1973 and later was to push energy towards higher prices. It is only now that given consumption is declining, have prices shown any weakness. During this period we also saw that energy sources, which in the mid-sixties would have been considered totally economic, were considered feasible and practical — this could be taken as oil from the Porcupine or our resources of peat or the North Sea oil in the United Kingdom. The problem as to whether these continue to be so or not is a matter now of conjecture.

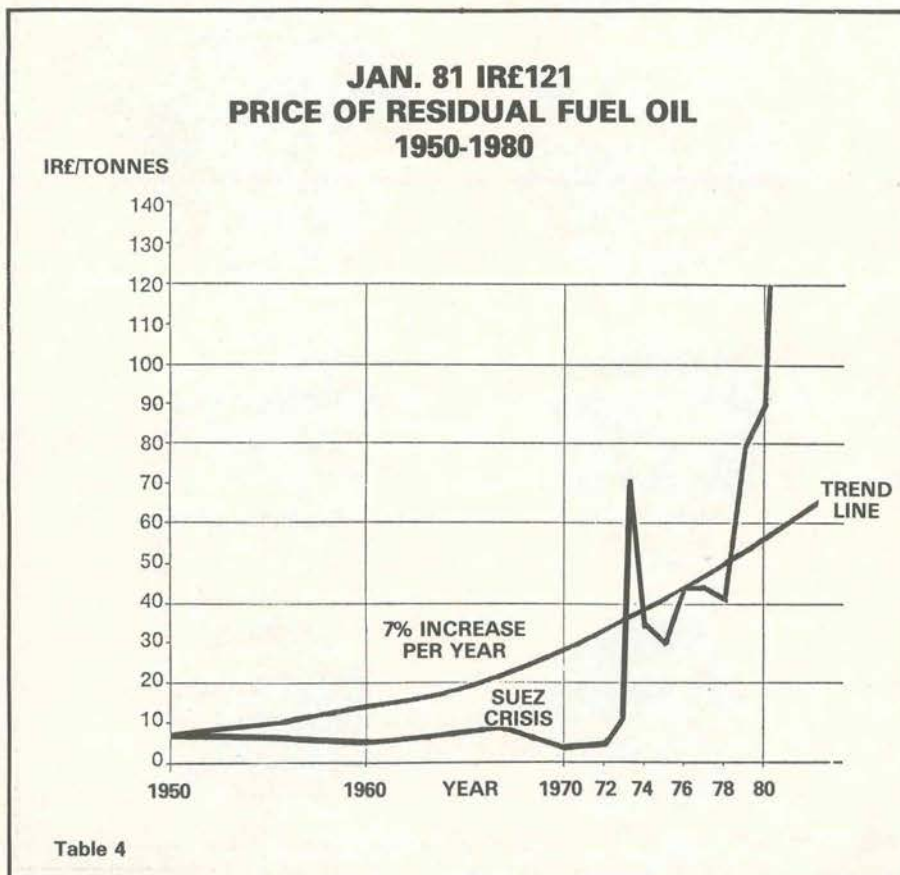
However, during this period, total energy demand in OECD countries increased. This is shown on Table 2.

**Table 2**  
**Total Energy Demand in OECD Countries**

	United States	Western Europe	Japan	Canada
1960	20.9	12.4	1.6	1.8
1965	25.4	16.5	3.0	2.5
1970	32.7	21.5	5.5	3.4
1975	34.9	23.2	6.7	4.1
1976	36.2	24.7	7.1	4.2
1977	38.0	24.8	7.2	4.3

**Table 3**  
**Changes in Oil Consumption (% per annum)**

COUNTRY	Annual Average	Percent Change From Prior Year				
	1960-1973	1974	1975	1976	1977	1978
United States	4.4	-4.8	-1.7	-8.2	4.9	2.1
United Kingdom	6.8	-6.0	-12.9	-0.1	1.4	2.6
France	12.4	-5.5	-10.1	8.0	-6.7	5.3
West Germany	12.3	-9.6	-5.6	8.9	-1.8	4.8
Italy	12.2	-2.9	-8.5	5.6	-1.1	2.5
Japan	17.9	-4.2	-2.5	2.8	4.9	1.3



We can see from the above table that there was an increase in energy demand up to 1977 but during this period we also saw a re-alignment in the provision of energy sources. To begin with, re-alignment with regard to oil consumption took place. The table below adequately shows this.

So we can broadly state that while there has been an increase in energy demanded in the main OECD countries, there has also been during that period, a decrease in oil consumption. Certainly in recent years there has been a further drop in oil consumption which has weakened prices.

It was during the 21 year period that the crisis in energy pricing, particularly oil, finally began to register. Firstly, prices rocket yet, now we are beginning to see the effects of price resistance. Table 4 shows this.

From this, two points can be noted:-

— From 1950 to 1973 there was no increase in oil prices. The OPEC hike in 1973 brought oil prices in one step to a level which was equivalent to an

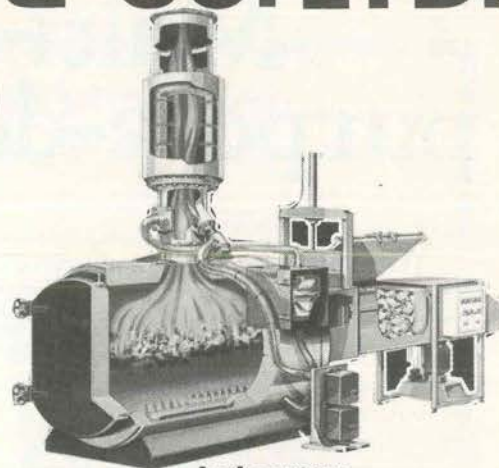
# JAMES GLEESON & CO. LTD.



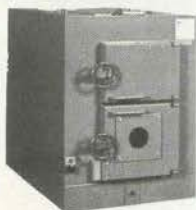
**Boiler Range**  
Oil/Gas/Tri-fired  
60,000 Btu/h to 20 million Btu

## HOVAL BOILERS & INCINERATORS

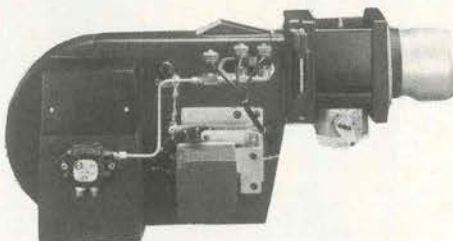
### CONTROLS & VALVES



**Incinerators**  
Range 2 cwt - 1 ton per hour



**HOGFORS BOILERS**  
Range 80,000 Btu/h to 4.5 million Btu  
Low, Medium and High Pressures



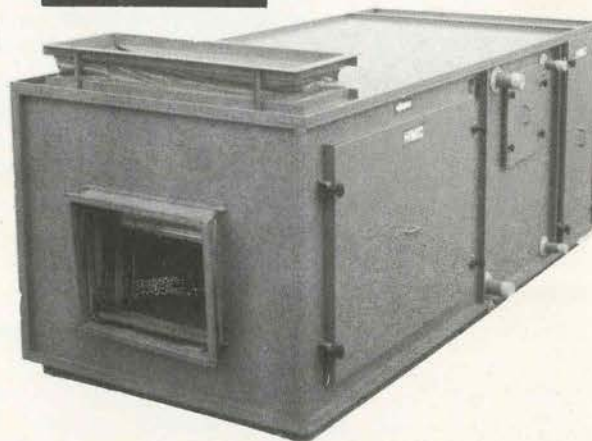
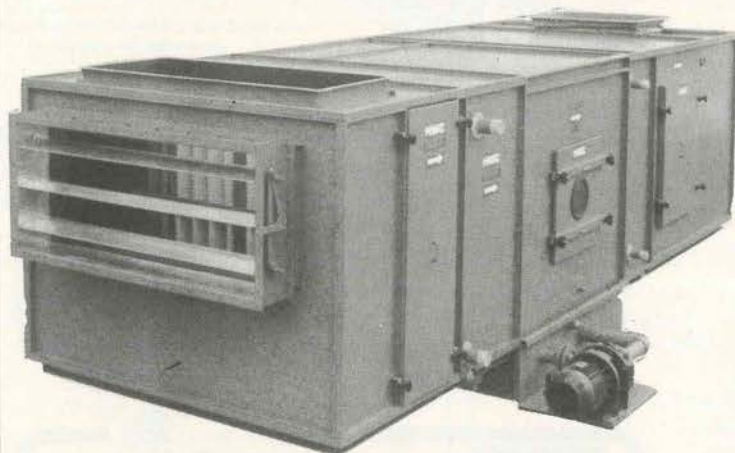
**WEISHAUPT BURNERS**  
Oil, Gas or Dual Fuel  
Using Light, Medium and Heavy Oils and  
all types of Gas. Range 80,000 Btu/h to  
96 million Btu.



**HOVAL-BIRAL PUMPS**  
Range 1gpm (.075 litres per sec) to 350gpm  
(26.25 litres per sec). Hydraulic & Dynamic  
balancing ensures vibrationless running.

**CAHERDAVIN, ENNIS ROAD, LIMERICK. TEL: (061) 54455/51731 TELEX 28287EI**  
**50 DARTMOUTH SQUARE, DUBLIN 6. TEL: 603432/605776.**

## DESIGNED BY



### Manufactured in Ireland by Redbro Manufacturing Ltd.

- Our service includes a fully computerized selection combining minimum first cost with maximum efficiency, smooth operation and low running costs. Accurate information on thermodynamic and aerologic performances as well as on noise level characteristics is available for any specific application.

- Maximum flexibility, easy mounting and maintenance is obtained with a complete range of standard sections performing one or two combined air handling functions such as mixing, filtering, heating, cooling, humidifying, etc.

Units available up to 100,000 M<sup>3</sup>/hr

## ACCURATE, QUICK DELIVERY DATES

CONTACT:— **REDBRO LIMITED**

Unit 12G, Cherry Orchard Industrial Estate, Ballyfermot, Dublin 10. Tel: 266677

Telex:— 30898.

# Multi-duct ventilation: purpose-designed by Vent-Axia

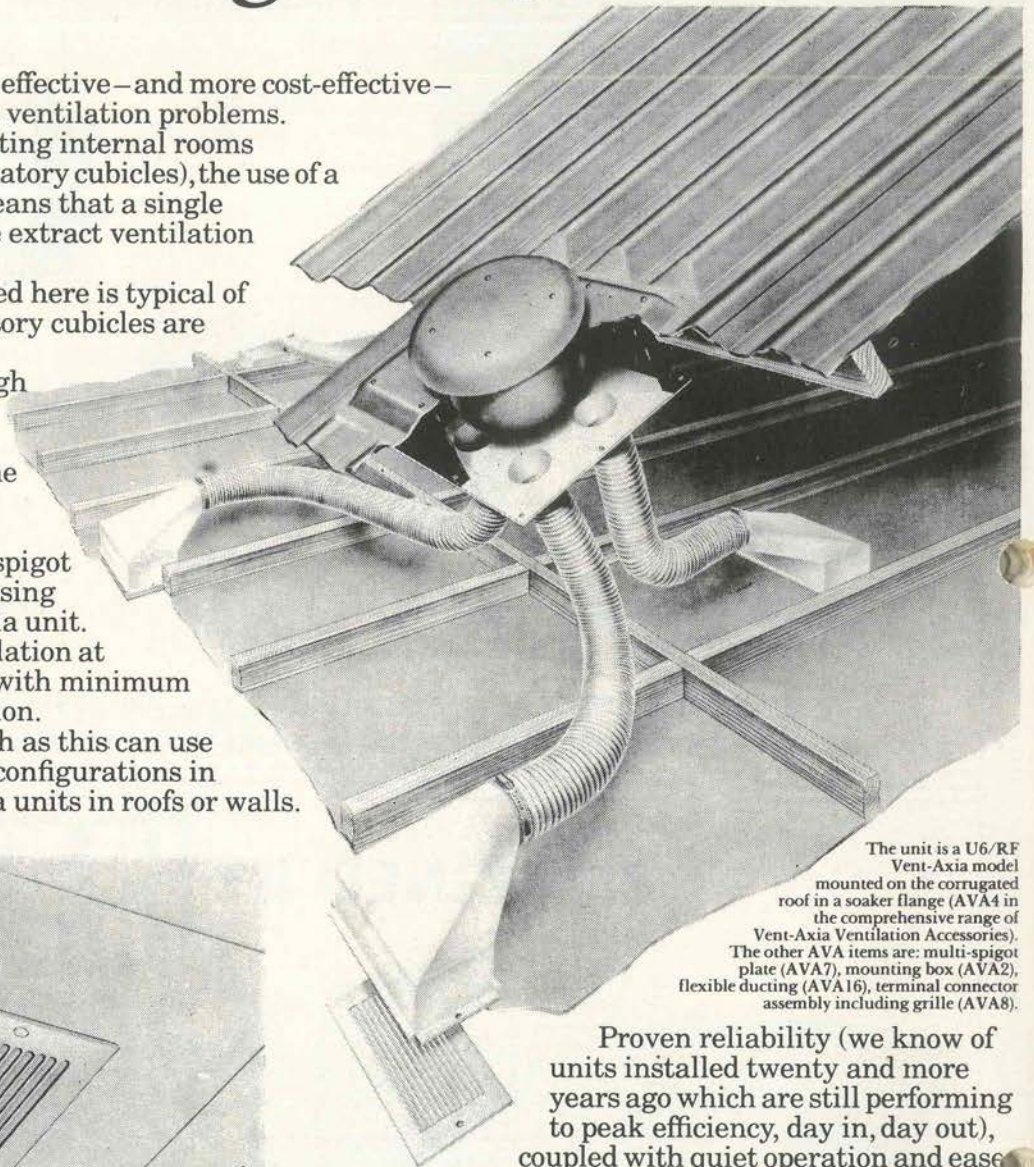
Vent-Axia means more effective—and more cost-effective—solutions to many different ventilation problems.

For example, in ventilating internal rooms (particularly individual lavatory cubicles), the use of a multi-duct system often means that a single Vent-Axia unit can provide extract ventilation for a number of cubicles.

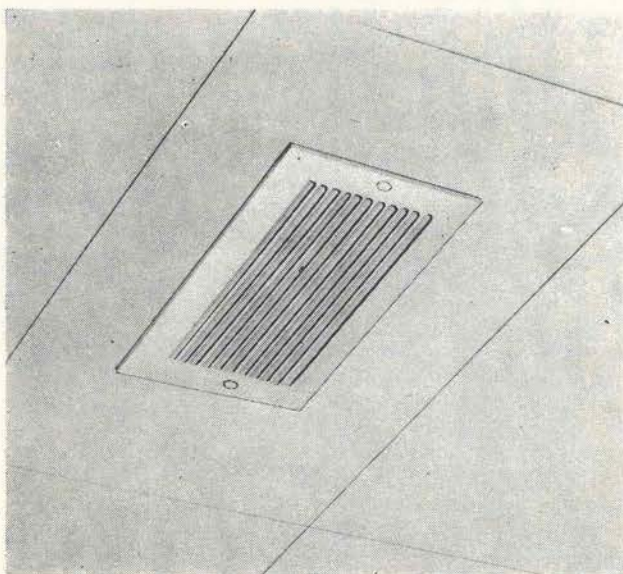
The installation featured here is typical of many: a series of four lavatory cubicles are ventilated by a single Vent-Axia unit fitted through the roof of the building.

In each cubicle, stale air is drawn through a grille in the suspended ceiling, passing through flexible ducting connected to a four-branch spigot plate mounted under a housing directly below the Vent-Axia unit. The result is effective ventilation at relatively low capital cost, with minimum disruption during installation.

Multi-duct systems such as this can use horizontal or vertical duct configurations in conjunction with Vent-Axia units in roofs or walls.



The unit is a U6/RF Vent-Axia model mounted on the corrugated roof in a soaker flange (AVA4 in the comprehensive range of Vent-Axia Ventilation Accessories). The other AVA items are: multi-spigot plate (AVA7), mounting box (AVA2), flexible ducting (AVA16), terminal connector assembly including grille (AVA8).

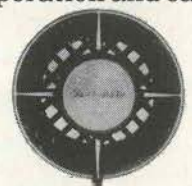


Neat, unobtrusive grilles conceal the terminal connector assembly and ductwork and provide for stale air extraction from the room.

Proven reliability (we know of units installed twenty and more years ago which are still performing to peak efficiency, day in, day out), coupled with quiet operation and ease

of maintenance, make

Vent-Axia Universal or Standard units the ideal choice for multi-duct internal ventilation.






**GKN AUTOPARTS (IRELAND) LTD.**  
 CAMAC CLOSE, EMMET ROAD, INCHICORE,  
 DUBLIN 8. PHONE: (01) 781700. TELEX: 30830.  
*Branches: Athlone, Cork, Galway, Kilkenny and Limerick.*

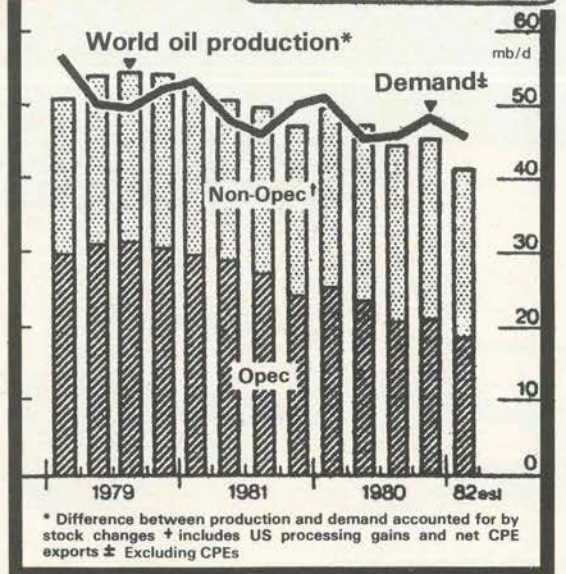
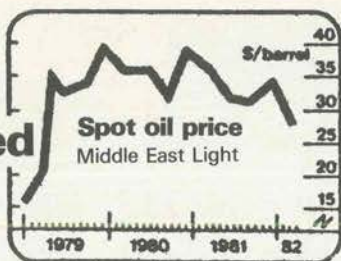
**DESIGN SERVICE AVAILABLE**  
*For further technical information and advice,  
 Write or Phone: Vent-Axia Division (01) 781700*

GKN Autoparts offer a design service and will be pleased to advise on the ventilation of internal rooms, and to draw up specifications if required.

Multi-duct ventilation. Just one of the many applications that add up to Vent-Axia: versatility in ventilation, with Universal and Standard units in four impeller sizes: 6" (152 mm), 7½" (191 mm), 9" (229 mm) and 12" (305 mm).



### Opec punctured



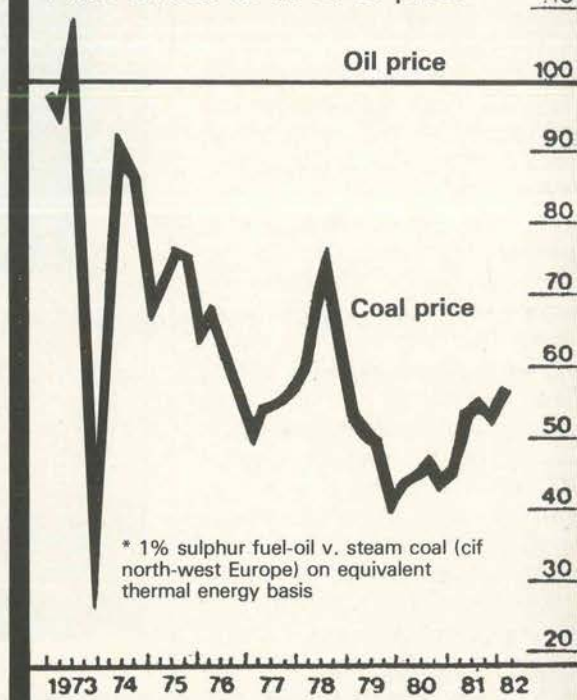
\* Difference between production and demand accounted for by stock changes † includes US processing gains and net CPE exports ‡ Excluding CPEs

Sources: James Capel, Petroleum Economics, Petroleum Intelligence Weekly

Table 5

### What price coal?

Price of coal as % of oil price\*



\* 1% sulphur fuel-oil v. steam coal (cif north-west Europe) on equivalent thermal energy basis

Table 6

annual inflation rate of 7% over the preceding two decades.

— From 1978 onwards energy prices have begun to race well ahead of general inflation levels.

However, as can be seen from Table 5, it is only now that prices are showing any sign of weakness.

Another beneficiary of the sources of re-alignment was coal. Coal had begun to drop from favour in the 1960's. It then re-emerged and is now being developed as an energy bridge to the future. Up to very recently it could be said that while World reserves were adequate for some hundreds of years, relatively little coal had crossed national frontiers, therefore there was no international trade as such, certainly not on the scale of oil. Since the 70's we have seen new investments in coalmines and in rail and harbour facilities, so the availability of coal has improved. The market price for coal, based on these new investments, has yet to be established. Table 6 however, shows the development of coal prices as a percentage of oil. As can be seen from this table the oil price advantage fell after 1973. Coal began to be looked upon with favour. Will it continue, well everything really depends on OPEC. If they continue to be in disarray, the answer is yes, if not, well —

During the 21 period, we have also seen nuclear energy generating capacity increase considerably. This is shown below.

As can be seen during this period, from 1960 to 1978, generating capacity World wide increased from 1,500 Mw to 108,000 Mw. Most of the stimulus coming from both the United States, which came from virtually zero, to having 49,800 Mw or half the entire World wide nuclear generating capacity. On the other

hand Western Europe having the same population accounts for only 25% of world nuclear generating capacity during that period. We can broadly say that in the twenty one years of this magazine, nuclear generating capacity has increased considerably. However, it was also during this period that the confidence of nuclear energy was shaken with a major incident at Three Mile Island. The success of having tapped energy found in uranium through controlled

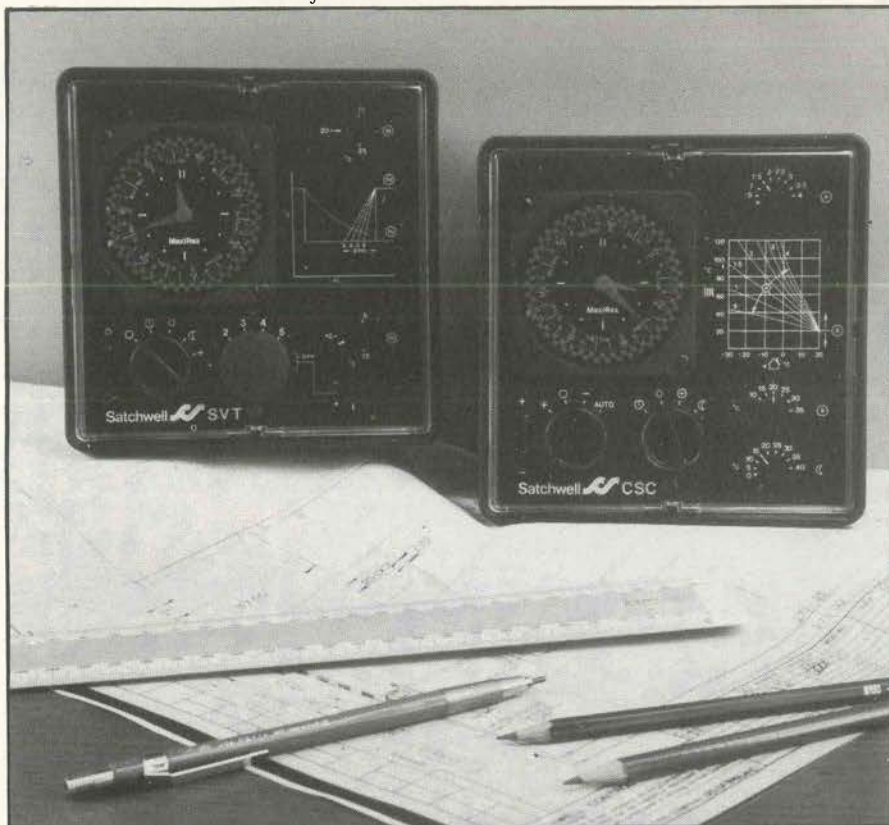
Table 7  
Nuclear Electric Generating Capacity at End of Year

	Total	United States	Japan	Western Europe	Canada	LDSs	Communist Countries
1960	1.5	0.4	0	0.5	0	0.6	
1970	17.6	6.6	0.8	0.2	0.4	1.6	
1971	24.6	9.4	1.3	10.6	1.3	0.4	1.6
1972	34.8	14.9	1.7	13.5	1.8	0.7	2.2
1973	42.6	20.3	1.7	13.8	2.3	0.7	3.8
1974	56.9	29.6	3.7	14.7	2.3	1.0	5.6
1975	70.6	36.8	5.0	17.9	2.3	1.0	7.6
1976	80.4	39.7	7.1	21.8	2.3	1.0	8.5
1977	93.3	46.0	7.6	25.2	4.0	1.0	9.5
1978	108.0	49.8	12.2	28.6	4.7	2.2	10.5

## DL'S ENERGY REPORT

fission had held great promise of a virtually inexhaustible energy supply. It was not so simple. Therefore, during this period the combined crisis of nuclear and of OPEC action and prices were a body-blow to Western Europe.

So, in broad World wide terms, we can say that there was problems in nuclear energy, we can say that there has been a development or re-emergence of coal, and we can also say that there has been considerable change in the petroleum industry. We can say that the undercurrents of fundamental change had begun in the 1960's and even before a dramatic change occurred during and after the 1973 Middle East war. During that time oil became a political tool and not merely a source of revenue. Arab members of OPEC, who themselves consume an insignificant amount of petroleum produced in the world, tried to bring industrial nations of the West to a political accommodation by withholding supplies of petroleum, so necessary in our energy-dependent Western culture. So during this period we have had considerable changes. Let's hope the changes over the next 21 years are not so dramatic.



● Two new low cost controllers from Satchwell Control Systems Limited, the SVT low cost optimiser and CSC simple compensator.

**CONSERVE  
ENERGY WITH**

# PENSOTTI

**CAST IRON BOILERS – OIL, GAS OR SOLID FUEL**



**P4N Series  
– 90°/91° Efficiency  
Natural Draught**

**Outputs 690,000 - 1.7 million Btu/h  
Virtually self-cleaning – unique design  
ensures minimum deposits**

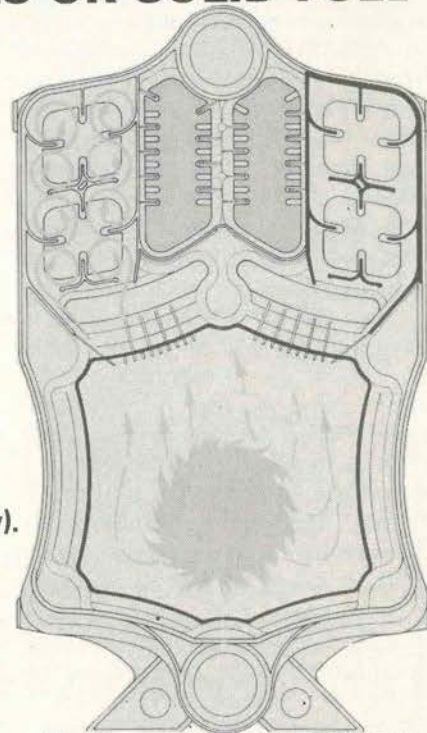
(for highest efficiencies, manufacturers recommend cleaning once a year).

The P4n is but one of a large series of Pensotti boilers. Range from 88,000 Btu/h (25 Kw) to 2.8 million Btu/h (825 Kw). 88,000 Btu/h to 1.3 million Btu/h available ex-stock. Package units supplied with Riello burners as standard.

from **heatmerchants**

Heatmerchants (Athlone) Ltd.,  
Deerpark Road, Athlone.  
Tel: (0902) 2194, 4120, 4135.

Heatmerchants (Kilkenny) Ltd.,  
Industrial Estate, Hebron Road,  
Kilkenny. Tel: (056) 21209 (3 lines)/  
(0409) 5983, 5998. Telex: 80068



Heatmerchants (Limerick) Ltd.,  
Thomond Shopping Centre,  
Roxboro, Limerick.

● CHECK CHANGED NEW TELEPHONE NUMBERS WITH OPERATOR.



# Thermoplant



THE SPECIALISTS IN

## COAL

Mechanical and pneumatic coal and ash handling systems

Coal fired boilers from 3,000 lb/hr steam to 100,000 lb/hr steam

Total system engineering available

## GAS

Boilers — Domestic and Industrial Burners

Measurement and control systems

Ball Valves, Meters and Controls

Detection and Explosimeters



All enquiries to:-

### THERMOPLANT ENGINEERING LTD.

2 Deans Grange Ind. Est.,  
Kill Lane, Co. Dublin  
Tel: (01) 850222 (01) 850641 Telex: 24409

Kilcoolishal, Glanmire, Co. Cork  
Tel: (021) 953224 (021) 822186  
Telex: 32360



### PANLUX electronic

A portable luxmeter with a very large range and fast indication. Colour corrected in all measuring ranges. Cosine-true.

Measuring ranges:  
0 ... 6,000 lux / 0 ... 120,000 lux or  
0 ... 600 fc / 0 ... 12,000 fc

Accuracy:  
max.  $\pm 5\%$  error of indication

Battery:  
9 V, IEC 6 F 22

Ordering No.  
5001-P014 (with lux scale)  
5001-P015 (with footcandle scale)



### SIXTOLUX

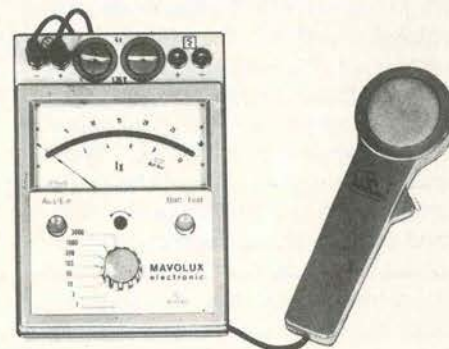
A small, handy to use luxmeter with 2 measuring ranges. Colour corrected: the spectral sensitivity of the photoelement is adapted to that of the human eye.

Cosine-true:  
inclined incident light is measured according to the cosine-law.

Measuring ranges:  
0 ... 3,000 lux / 2,000 ... 60,000 lux

Accuracy:  
 $\pm 10\%$

Ordering No. 5099-P034



### MAVOLUX electronic

A high sensitive, portable luxmeter with recorder output

Eye-corrected in all ranges

Cosine-true

Measuring ranges:  
0 ... 3,000 lx / 0 ... 60,000 lx

Accuracy:  
max.  $\pm 5\%$  error of indication

Battery:  
4 mercury batteries 1.35 V each

Ordering No. 5008-P001



## INDUSTRIAL INSTRUMENTS LTD. — The Instrument People

6 Herbert Place, Dublin 2. Tel: (01) 761691 Telex: 24789 Kilcoolishal, Little Island, Cork. Tel: (021) 935224 Telex: 75320

Eric McBride has been contributing to H&V News almost from the start and this month, which is our 21st year of publication, we would like to pay tribute to his dedication to the industry and his deep interest in energy matters in general. Without doubt there are few to equal Eric's knowledge, not only in Ireland, but also in Europe, on energy matters and H&V News is most fortunate in having someone of his calibre to contribute articles and news particularly from Northern Ireland. Again, thanks Eric and may you be still contributing in our 50th year.

— EDITOR



# 21 TODAY

Elsewhere you will have noticed that I.H.V.N. journal is celebrating its 21st birthday this year. No doubt there are many other companies and organisations doing the same — two we know of in Northern Ireland are the Institute of Energy and the Coal Advisory Service.

The first meeting of the N.I. Section of the Institute took place in the Spring of 1961 in what was the then Grand Central Hotel, Belfast. At that time the branch as that is what is only entitled to call itself had a bare membership of about 40. Now it is over 200.

The Coal Advisory Service a small organisation of about 6, sponsored by the Northern Ireland Coal Trade and the National Coal Board was set up to advise and promote the use of solid fuel. Now 21 years later it employs over 100, has a large service and publicity organisation, this year dealt with its millionth enquiry and has showrooms and advice centres throughout Ulster.

Twenty one years ago, the steel boilers were being introduced, cast iron sectional boilers were standard, room heaters and closed stoves were just beginning to appear.

Circulating pumps were pieces of engineering that a person had difficulty to lift with both hands — no such

thing as variable heads and plastic casings.

Copper pipe, was pipe, pipe that you had to work with, fittings were bulky and certainly the unobtrusive installation expected to-day would have been difficult to achieve.

This period also saw the oil companies make a determined effort to get with the domestic market — who will forget the Shell Mrs 1970 campaign. This and that undertaken by other companies was extremely successful as they captured most of the middle and upper class market. Twenty one years later we see the swing back to solid fuel with coal leading the way.

Panel Radiators now accepted as standard were just becoming to be accepted and of course the great interest in domestic heating justified their popularity and introduction.

The Heating market in Ulster was in the hands of about a dozen companies, who combined both the Industrial & Domestic field. It was only later the specialised Domestic contractor appeared and the larger firms pulled out of the domestic scene, which in turn has led to a difference in the labour market — one group specialising in the heavy work and the other in the light.

Strange as all this may seem there has been little or no technological

change. Materials have changed, equipment is lighter and more compact. There is more use of controls and plastic but the basics have remained.

One would doubt if the equipment installed to-day will still be in use in 21 years time like its now "come of age" predecessor but on the other hand with the modern quick change of fashion is it necessary for it to last?

The biggest changes and advances has been in domestic plumbing, where the new materials have really been put to the best use.

Bathroom and kitchen ware must not only be functional but it must carry design features and colour to match many varied tastes. Likewise insulation has now become a feature taken into consideration in planning and buying.

It has been an interesting twenty one years, fortunes have been made and fortunes have been lost and it is safe to say that the period has produced more optimists than pessimists. No doubt when the year 2,000 comes someone will have developed the solar multi fuel, double glazed heat pump, operating from a wind powered wave generator or will we all be up to our ears in biomass.

F.R. McB

Modern Plant Components Ltd of 195 York Road Belfast has commenced operations under the management of Mr Mark Hewitt. The company will distribute both mechanical and electrical products. The mechanical products included so far are the Alcon range of Solenoid valves, Yarway Steam Traps, Blundenburg pressure gauges and Birkett pressure reducing and safety relief valves.

\*\*\*\*\*

Edwards & Edwards Ltd the Belfast electrical wholesalers have been appointed regional distributors for Siemens Prototherm panel and skirting heaters. The heaters manufactured in Norway are one of Europe's market leaders, are finished in a neutral white finish.

There are six panels type and four skirting with an output range from 0.6Kw to 2.0Kw. Each heater is fitted with an ultra sensitive thermostat and is supplied with all fittings for wall mounting.

\*\*\*\*\*

Dr. McIlhaggen of Queens University addressed the Belfast Association of Engineers on the storage of energy generated by the many sources of alternative energy now being discussed such as wind power, solar power and wave energy.

\*\*\*\*\*

John Crossan, Managing Director of Modern Prefabrication welcomed Guests to the Park Avenue Hotel, Belfast to introduce their new heat pump, known as the "Modheat" Heat Pump. The heat pump which is manufactured in Belfast has a special infra red control system to ensure adequate defrosting of the refrigeration coils. It is hoped to make an advance to the Local Enterprise Development Unit in the very near future to set up a small factory unit for the production of the units.

The Irish distributors of the Modheat Heat Pump will be Interlink Heating, 36 Hamilton Road, Bangor of which Mr Ian Morrison is a Director.

\*\*\*\*\*

One of the best known persons in Galvanising in Northern Ireland, Mr Dermott McConnell, has joined the Galvanising Division of the Simms Steel Group at Hulls Hill Lisburn.



● Pictured at the recent Northern Ireland Section of the Institute of Energy — Savell O Hicks Memorial Lecture & Lunch. Principal guests included: Sir Derek Ezra MBE, Chairman, National Coal Board; R. T. Jordan, MBE, Chairman N.I. Section; Lord Gowrie, Minister of State, N.I. Office; Sir John Hill, President, Institute of Energy; F. R. McBride, MBE, Hon. Sec. N.I. Section.

Mr McConnell was for many years with the old Wellington Tank Co before forming his own company Galvio N.I. Ltd which is now closed.

\*\*\*\*\*

We regret the death of Lieut. Commander Pat Hume. In the early 60's Pat formed his own Company W.F.F. Hume and played a major part in the introduction of oil burning on a major scale into the Province. For many years he distributed Potterton products. A well known and respected pipe smoking character Pat left the heating trade, to do some farming and kept his connections with the sea by becoming Harbour Master at Kilkeel.

\*\*\*\*\*

Over 250 people crowded into the function suite of the Culloden Hotel, Craigavad for the first Savell O. Hicks Memorial Lecture, sponsored by the Northern Ireland Section of the Institute of Energy to be followed by the Institute Lunch.

Mr. F.R. McBride, M.B.E., Honorary Secretary of the Section paid a special tribute to Savell O. Hicks, O.B.E. who had been a Committee member of the Section and who prior to his death had served the Institute and the Northern Ireland Section for twenty years. Tribute was also paid to Mr. Hicks for the work he had done during his life to enhance the industry and prosperity of the Province.

The memorial Lecture was given by Sir Derek Ezra, Chairman of the National Coal Board, who chose as his subject — "Coal — The Fuel for the Future".

In his talk, Sir Derek spoke of the world reserves of coal, particularly relative to the current fuel oil situation. He expressed the view that the advent of the oil companies into the coal business could mean that if they decided to use their oil expertise to

market coal, a completely new system of coal marketing could result.

Sir Derek was of the opinion that help and assistance should be given to those who wished to convert to coal. He thought that a decision to convert the Ulster based Kilroot Power Station should be made now.

Following his formal talk, Sir Derek Ezra took part in a question time, answering many questions from the many representatives of industry and commerce who had attended.

Following the Lecture, the large attendance attended a pre-lunch reception.

Mr. R.T. Jordan, M.B.E., Chairman of the Section, presided over the Lunch, where the Lord Gowrie, Minister of State at the Northern Ireland Office proposed the toast of the Institute. In his speech, Lord Gowrie spoke of the problems facing the Province relative to the local and world energy scene. He spoke of the part the Institute could play in solving these problems.

In his reply, Sir John Hill, President, spoke of the difficulties facing the Institute, particularly relative to the new Engineering Board. He spoke of the help the Section received from Government and Local Authorities when congratulating the Section on its twenty-first birthday.

Mr. R.T. Jordan, M.B.E. welcomed the many and distinguished guests including Lord Blease, Sir D. Ezra, Sir E. Bell, Sir John Andrews, K. Bloomfield, C.B. to mention but a few, drawing attention to the fact that we not only had the Government spokesman for Northern Ireland in the House of Lords present but also the Opposition spokesman.

The reply, on behalf of the guests, was given by Don Jones, Divisional Director of Esso Petroleum Co. Limited, who expressed their pleasure in an extremely witty speech.

Thus ended, what was without

**ULSTER NEWS**

doubt, one of the most successful functions ever organised by any professional Institute in Northern Ireland.

\*\*\*\*\*

The Northern Ireland Branch of the Institute of Domestic Heating Engineers have announced details of their social programme for 1982. This is as follows.

**22nd April 1982** — The Annual Curling and Golf outing in Stranraer. Phone W. McMichael at Dundrod 353 for further details and time of departure of the Larne-Stranraer Ferry. This event will be sponsored by O.B.C. Ltd.

Golf outings and their sponsors and venue are as below:

**28 April** — Helens Bay — U.D.T. and Carplant Ltd.

**8 June** — Royal Belfast — Thorn Heating Ltd.

**30 June** — Clondeboye — Fuel Services Ltd.

**26 August** — Malone — N.F.B.P.M. (N.I. Region).

**16 September** — Knock — I.D.H.E. Golf Soc.

The Annual General Meeting will take place at the Strangford Arms Hotel, Newtownards at 7.30 p.m. - 20th April 1982.

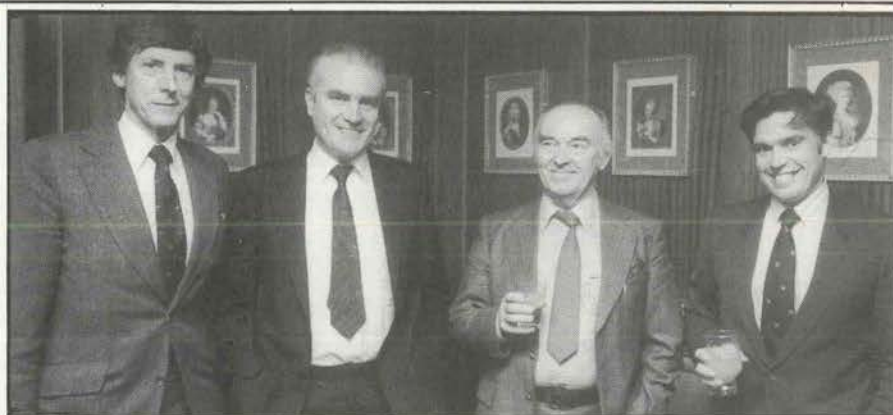
Further details of all the Branch activities are available from the Hon. Secretary Brian Page, 17 Erinvale Avenue, Belfast.

\*\*\*\*\*

We have just heard of the death of George Craig who while not a member of the heating trade was certainly well known to many of us having covered trade shows, dinners and social functions for this and many other publications, with his camera.

For many, George's presence was an integral part of any function but few realised that even though his forte appeared to be his camera, his real love was music. For many years before the war he sailed the world on the cruise liners as a member of the ships orchestra, he played for E.N.S.A. during the war and was a member of the Ulster Orchestra at the same time he played in and with many of the well known "big bands" when they toured in Ulster.

No more will he hear — one more for the police gazette gentlemen please — but we will remember his cheerful personality with affection.



● At the Savell O Hicks Memorial Lecture were D. Hinchliffe, Alkali Inspector (NI); D. Patterson, Short Bros. & Harland Ltd.; Z. Lorenc, Du Pont (UK) Ltd.; and R. Smith, Du Pont (UK) Ltd.



● Dr. Smith, Esso Petroleum; J. Gaston, Chief Executive, N.I. Electricity Service pictured at the Savell O Hicks Memorial Lecture.

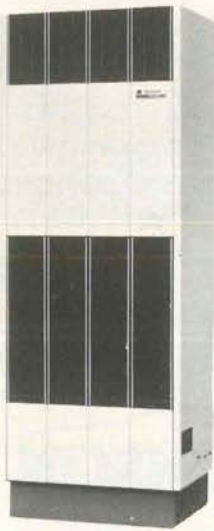


● Other guests at the Savell O Hicks Memorial Lecture were A. McCullough, Sec. B.I.M. (N.I.); Lord Blease; Dr. McClements, Director, N.I. Economic Council; and F. R. McBride, MBE, Director John Kelly Ltd.

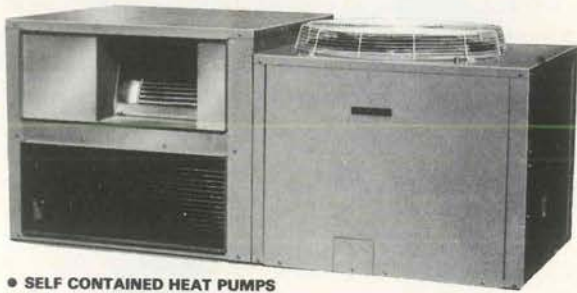


● J. S. Robinson, IES Industrial (Ireland) Ltd.; Pat Fleming, IIRS; B. Thompson, Chief Engineer, Dept. of Health, Works Unit; C. Monaghan, C. Monaghan & Co.; and R. Hobson, IES Industrial (Ireland) Ltd. at the Savell O Hicks Memorial Lecture.

# ENERGY EFFICIENT HEAT PUMPS



● SPLIT TYPE AIR COOLED HEAT PUMPS



● SELF CONTAINED HEAT PUMPS

- 60 MODELS AVAILABLE
- COMMERCIAL TO HEAVY INDUSTRIAL
- RANGING FROM 12,000 Btu/h TO 500,000 Btu/h

**Score on Reliability**  
**Contact the Only Heat Pump Specialists**  
**in Ireland**

AIR CONDITIONING,  
 REFRIGERATION &  
 ENERGY SYSTEMS FROM:

*clean-line*

94 MEATH STREET, DUBLIN 8.  
 TEL: 718965/752200 TELEX: 92288

**DUFFERIN**  
**Industrial Services**  
 provide a complete  
**CLEANING SERVICE**  
 to Industry.



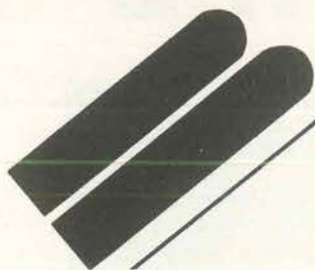
**DUFFERIN** carry out  
**CHEMICAL CLEANING** and **HYDRA-BLASTING**.  
 We are High Pressure Water  
 Washing-Jetting Contractors.

Anywhere -  
 Anytime - Contact: **Dufferin**

19A Dunowen Gardens  
 Belfast BT14 6NR

INDUSTRIAL SERVICES LTD.

Telephone: Belfast 743388.



**Blackenberg Ltd**

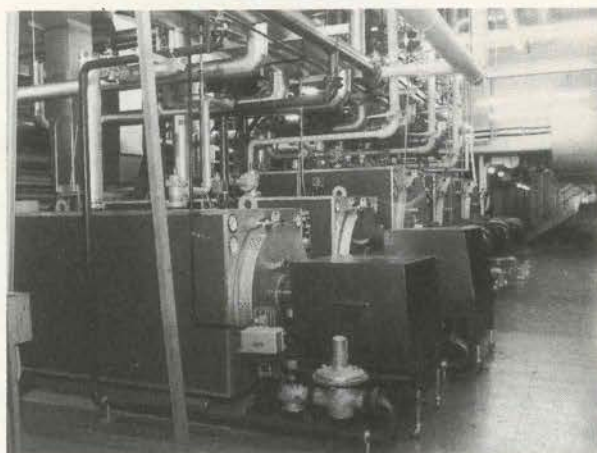
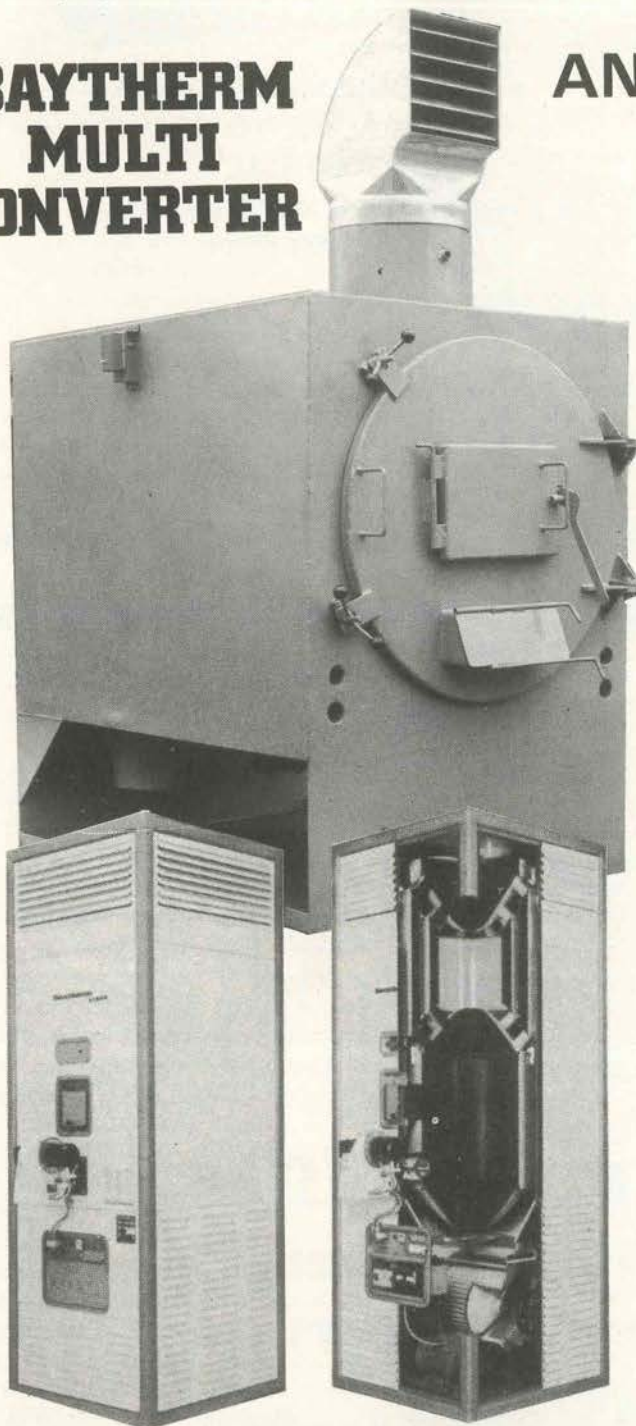
Baldoye Industrial Estate  
Grange Road, Baldoye  
Dublin 13

Telephone: 393071/393126

**BAYTHERM  
MULTI  
CONVERTER**

**AND**

**R. TOMLINSON**



Steam Boilers 150-600 lbs/hr  
Taurus Range 1,250-20,000 lbs/hr  
Omega Hot Water Boilers 650,000 btu/h-20,000,000  
btu/h  
Oil or Gas Fired Hot Water Boilers 50,000 Btu/h -  
800,000 Btu/h  
Baytherm Multi Converters 200,000 Btu/h,  
300,000 Btu/h, 500,000 Btu/h



**Dantherm**  
WARM AIR HEATERS

Free Standing or Horizontal Up to 90% Efficiency  
100,000 - 2 million btu/h

**Dantherm**  
UNIT HEATERS

40,000 - 400,000 btu/hr in Hot Water  
40,000 - 200,000 btu/hr in Electricity



● THE FOLLOWING IS  
INFORMATION  
CARRIED OVER FROM  
LAST MONTH'S ULSTER  
REGIONAL REVIEW

## HEAT TRACE

The heat tracer is designed for low temperature maintenance duties, and is particularly suited for frost protection of pipework, whether metal or plastic. Typical applications include the heating of sugar, glucose, chocolate, caustic solutions, light oils etc. The heat tracer may be site terminated and applied in either a straight or spiral fashion onto the pipe.

Control is desirable for all E.S.H. systems by means of Heat Trace thermostats, sensing pipe or ambient temperature, or both. Pipe sensing is essential on plastic pipes. The pipework should be thermally insulated as required.

For hazardous areas, consult Heat Trace Ltd., or local agents McCaig Collim Ltd., 6-8 Greenwood Ave., Belfast, BT14 3JJ, Tel: 656212-3-4, Telex: 747091.

## BOTAN

Automatic electrode boilers generate either steam or hot water by passing electric current between electrodes immersed in water. They are compact, need no flue, their efficiency is between 95% and 98%, they are safe to operate and no current can flow in a dry boiler. They can be sited alongside the plant using steam so reducing the piping costs and heat losses to a minimum.

Because the operation of the boiler requires a current to flow between the electrodes, it will not operate with very pure feed water. Conversely, very impure water will reduce the water's resistance to the flow of current; the optimum conductivity level is between 400 and 700 micro-mhos per cubic centimetre.

Scale formation should be avoided as the scale will progressively insulate the electrodes reducing the boiler's capacity. Sludge must not be allowed to accumulate in the bottom of the boiler as this can cause a short circuit between the electrodes.

The make up water for electrode boilers should be base exchange softened to reduce the hardness to zero unless the water is of zero hardness.

The feed water to the boiler is treated with Botan FT4 at the rate of 0.024 litres (1/5 pint to 1000 gallons) to every 1,000 litres of water if a steam boiler or 1.25 litres to every 1000 litres in the system (1 pint to 100 gallons) if a heating boiler in a closed system; any water added to the heating system is treated in the same ratio of 1.25 litres to every 1,000 litres of additional water.

### Purpose and Properties of Botan FT4

To maintain the TDS above 400 micro-mhos.

To prevent scale formation.

To scavenge the oxygen in the feed water and so obviate corrosion.

To act as a sludge conditioner is keep the sludge mobile and ensure it is removed when the bleed valve or blowdown valve is opened.

To maintain the alkalinity within the boiler and prevent corrosion.

Further details from G. W. Monson & Sons Ltd., 18 Ballybrack Rd., Newtownards, Tel: 812350.

## AAF LTD.

There is a high quality AAF filter for every application that exists. Each AAF filter type is rigorously tested both in laboratory and on site before it qualifies for inclusion in the AAF product list. AAF long life natural glass and synthetic media filters are manufactured to exacting standards to ensure complete superiority over alternative makes.

AAF Ltd. is at the forefront of technology in the development of air filtration products and systems.

The same expertise that won orders to provide the air filtration systems in moon landing modules is applied to all AAF filter technology — including domestic air conditioning systems.

Over 70 years experience in all aspects of air handling and filtration is behind the development of the AAF range. You can specify AAF filters with complete confidence.

Confidence that your filter will last longer and give you the most cost-effective continuous performance.

### New Product

AM-AIR 300 filters are designed to operate in the 300 to 500 FPM filter face velocity range. (Four inch deep sizes can go up to 625 FPM). They

provide significantly high efficiency than disposable panel filters, permanent filters or media pads in metal frames. AM-AIR 300 filters are highly recommended for applications where these types of filters are presently being used and a higher level of air cleaning is desired.

AM-AIR filters are also directly interchangeable with panel type filters without modification to the holding frames or latching devices.

AM-AIR 300 filters consist of a white pleated media pack enclosed in a blue heavy duty chipboard frame. They are available in three depths — 1", 2", and 4". They are unusually strong and will not rack or warp with normal handling or under normal operating conditions.

Further information from AAF Ltd., Belfast and Dublin.

## BSS LTD.

Dewey Waters have been making GRP mouldings since 1958 and offer well designed and well produced, properly tested products.

The principles of sectional tanks are generally well known and Dewey Waters GRP tanks share these basic principles, but for those not familiar with them the tanks are formed by bolting together a series of flanged GRP panels. In the main they are bolted through their flanges sandwiching a mastic strip to provide a watertight seal.

Following initial design work a full programme of testing was completed with the assistance of the Stress Engineering Department of a local Polytechnic. Deflection tests of panels were carried out and similar tests on sample tanks plus a complete read out from a series of inbuilt strain gauges bonded within sample panels was undertaken and the current well designed, well engineered panels resulted.

Despite the strength of these panels all but the smallest tank assemblies require additional reinforcement and this is provided in two ways:

1. Internal patented stainless steel system.

2. External R.S.J. support system.

Dewey Waters offer two series:

1. Imperial based on 4' x 4' panels with 1/2 and 1/4 panels available.

2. Metric based on 1 metre x 1 metre panels also with 1/2 and 1/4 panels.

Further details from BSS Ltd., Ballysillan Industrial Estate, Belfast BT14 8EZ, Tel: 740221, Telex: 74561.

# Take a few pro.

## Seal-ring joints only where needed for thermal expansion

The Terrain soil system uses seal-ring joints only to accommodate normal expansion. Fewer joints mean fewer fixings, and savings in time and labour.

## Stress-free solvent-welded joints

A true weld, as strong as the parent material. The system is stronger, more rigid, and needs less support.

## Accessibility throughout the system

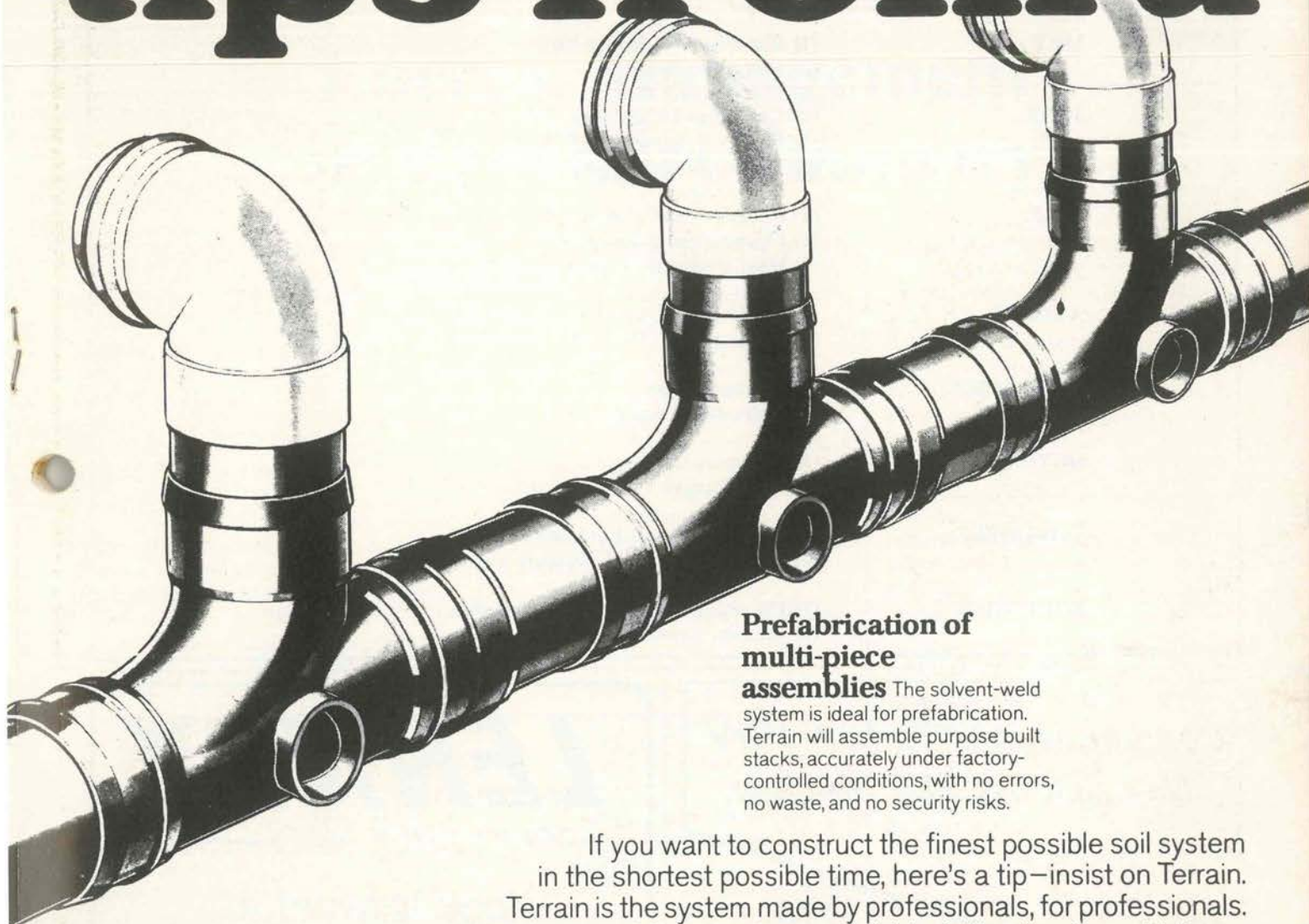
Our branches, bends and connectors provide maximum access. In addition, access doors are available where required.

## Close coupling bend for tight areas

Terrain is ideal for installation where space is limited, as in narrow service ducts.

The logo for UNID, consisting of the word "UNID" in a bold, italicized, sans-serif font, enclosed within a rectangular border.

# tips from a



## **Prefabrication of multi-piece assemblies**

The solvent-weld system is ideal for prefabrication. Terrain will assemble purpose built stacks, accurately under factory-controlled conditions, with no errors, no waste, and no security risks.

If you want to construct the finest possible soil system in the shortest possible time, here's a tip—insist on Terrain. Terrain is the system made by professionals, for professionals. Its solvent-weld joints give you a rigid, stable structure which can be put together on site, or prefabricated in the factory. And either way, it needs less support—which means faster and easier installation. Find out more about Terrain drainage systems today. You'll find we've got all the answers at our fingertips.

**Telephone 771801 for technical advice**

# **ARE TERRAIN SOIL**

## **Systems for Professionals.**

**Unidare Limited, Finglas, Dublin 11. Telephone 771801**

## Features for the Rest of '82

The following is a list of features planned for the rest of the year. If you are involved with any of the products we have listed we will be delighted to receive editorial material — especially photographs — and new product information which we will do our best to include in the feature concerned.

<b>MAY</b>	(1) Exoclima — Hevac Preview (2) Rainwater Systems
<b>JUNE</b>	(1) Gas Ireland Catalogue (2) Boilers & Burners — Industrial & Commercial (3) Grilles, Louvres and Ducting
<b>JULY</b>	(1) Radiators and Convectors (2) Chimneys and Refractories (3) Heat Recovery — New Feature
<b>AUGUST</b>	(1) Air Handling Units (2) Insulation — Thermal & Sound
<b>SEPTEMBER</b>	(1) Sanitary Ware (2) Instruments and Controls
<b>OCTOBER</b>	(1) Domestic Boilers (2) Heat Pumps: New Feature
<b>NOVEMBER</b>	(1) Cold Stores and Equipment (2) Storage Tanks and Pressure Vessels
<b>DECEMBER</b>	(1) Plumbing Equipment and Supplies (2) Seasons Greetings

*Congratulations To Irish H&V  
News On Its 21st Birthday.*

  
**Vent-Axia**  
The first name in ventilation

Sole Distributors For The Republic Of Ireland:—



**GKN AUTOPARTS (IRELAND) LTD.**  
Camac Close, Emmet Road, Inchicore,  
Dublin 8. Phone: (01) 781700  
Telex: 30830.

# LENNOX

Systems for all seasons

look forward to  
congratulating the  
“News” again after  
the next 21 years!

LENNOX INDUSTRIES LTD.,  
P.O. BOX 43, LISTER ROAD,  
BASINGSTOKE, RG22 4AR

- LENNOX heating, ventilating and air conditioning systems for all seasons are available through

 **C&F Limited**

Glenside Industrial Estate, Mill Lane,  
Palmerstown, Dublin 20. Phone 264 898

# Energy Management in the Dairy Industry

Over £12 Million, at current energy costs, has been saved by Waterford Co-op Society through reduction in its primary fuel utilisation over a six year period of expansion. This was announced recently by Mr. Pat Dineen, Manager - Dairy Products Division, Waterford co-operative Society Limited, at a meeting of the Energy Management Association in Dublin.

Mr. Dineen outlined to the meeting the various aspects of Waterford's co-ordinated programme of energy management and stated that potential still exists to further reduce the Co-operative's primary fuel input while maintaining current levels of production. The following are the details of Waterford Co-op's energy conservation.

Waterford Co-Op Society Ltd. is one of the major multipurpose co-operatives in the Country. The total turnover of the Co-Operative in 1981 amounts to £120 million while the total assets stand at £58 million.

The organisation has grown at a fast pace over the past years as a result of amalgamations with smaller Co-Operatives and also due to the rapid expansion of dairying in the region. The following figures give an indication of the growth rate which the Organisation has experienced in recent times.

Over eighty per cent of the total milk pool in Waterford Co-Op Society Ltd. is processed at the central processing complex at Dungarvan.

The main products produced at Dungarvan include: Whole milk powder, Skim milk powder, Fat filled powder, Calf milk replacer, Casein and Butter.

Waterford Co-Op was among the earliest processors in the Country to appoint a fulltime Energy Manager in 1974. This appointment no doubt paid dividends and we can now report that in 1981 we consumed less oil than we did in 1973 although the quantity of milk processed has increased dramatically over the period.

### Achievements To Date On Energy Conservation

In 1973, 44 million gallons of milk were processed in our Dungarvan plants, using a total of 2.8 million gallons of heavy fuel oil. In 1981 the quantity of milk processed increased to 74 million gallons, while the fuel oil consumption amounted to 2.45 million gallons.

This represents an increase in the ratio of gallons of milk processed per gallon of oil consumed, from 15.7 in 1973 to 30.2 in 1981, or an overall reduction of 2.25 million gallons of fuel oil per annum. At current oil costs this improvement is worth £1.6 million per annum.

During the same period the electrical consumption has increased from 14.4 to 14.8 million units, which represents an increase of 2.8% in total but corresponds to an increase of 64% in the number of gallons

processed per unit consumed.

In Dungarvan we generate high and low pressure steam. Eighty five per cent of our total steam produced (243 X 10<sup>6</sup> Lbs.) is utilised in milk dehydration. The balance is utilised for the pasteurisation of milk and cream, for buttermaking and for cleaning.

From the figures already quoted it is evident that we have achieved an increasing efficient use of steam through a consistent energy saving programme initiated in 1974. In pursuit of this programme greater efficiency has been achieved in the following areas.

- Greater efficiency of steam use in milk powder production.
- Utilisation of condensate from all sources.
- Insulation of all steam and refrigeration lines.
- Maintaining consistently efficient boiler operation.
- Maintenance of pipe lines to prevent leaks.
- Measurement and recording of all steam and electrical usage in plants.
- General good housekeeping measures to reduce wastage.

### Greater efficiency of steam use in Milk Powder Production

There are two stages in milk powder production.

- (a) The milk is condensed within an evaporator to remove excess water.
- (b) The condensed milk is dried to the powder state using hot air in the spray drier.

From the outset it was realised that the spray drying process was the least efficient. Through measurement it was found that it takes approximately 15 times more steam to remove water in the drier than in the evaporator.

The achieving of greatest efficiency from the evaporator was therefore of paramount importance in reducing energy costs.

Originally the solids content of the

	TOTAL SALES	TOTAL ASSETS	PROCESSED
	(£ 000)	(£ 000)	(Gls.000)
1970	5,000	4,708	26,000
1973	11,000	8,463	44,000
1975	39,000	15,000	61,000
1981	120,000	58,000	93,000

**TABLE I**

**ENERGY MANAGEMENT IN THE DAIRY INDUSTRY**

condensed milk was not accurately controlled, and in consequence approximately 45% solids was normal.

It was then established that an increase of 1% in solids will save 2 gallons of oil per tonne of product produced. The maximum concentration of 48% solids is now accurately controlled to ensure the greatest practical efficiency in terms of energy utilisation. This results in an annual saving of some 100,000 gallons of oil or in monetary terms at current oil costs £70,000.

Further savings were achieved within the evaporators by scheduling a controlled cleaning programme. The net result was a reduction in cleaning time of 30 minutes and this further reduced the annual oil consumption by 60,000 gallons or in monetary terms at current oil cost £42,000.

Improved efficiency has been achieved in the powder driers by introducing two stage drying in all our drying plants with one exception. Two stage drying increases the capacity of a plant by approximately 30% and reduces steam consumption by 12%.

A 12% reduction in steam consumption results in an overall saving of 160,000 gallons of oil or at current prices this amounts to £112,000.

Should the moisture content of the powder vary by one percent from specification the additional drying would represent an annual usage of 5,000 gallons of oil. This moisture level is therefore controlled as closely as possible to the specified standard.

Due to the fact that our throughput was increasing dramatically during this period, we had the opportunity of selecting the most efficient plant available to cope with our increasing volume of production.

**Utilisation of condensate from all sources**

The condensate from the steam system is all collected and returned to the boiler house where it is used as feed water. This is further augmented by the condensate from the first stage of the evaporators which is almost pure water.

The hotwell tanks, which are converted Paxman boiler shells, are at a high level in the boiler house. This helps in preventing cavitation in the feed pumps. Each hotwell holds 30,000 gallons and is controlled by a level probe system.

Condensate from the remaining

effects of the evaporator is utilised for preheating the drying air of the spray drier to approximately 35°C. This represents a saving of approximately 10% in steam consumption in the drier which at current oil costs represents a saving of £56,000 per annum.

The condensate is then returned to a third tank at low level in the boiler house which has a capacity of 10,000 gallons.

The top and bottom tank temperatures are consistently at 80°C and 53°C respectively. If the level in the top tank falls it is topped up with hot water from the lower tank. Should all three tanks be full the excess is diverted to two 50,000 gallon stainless steel storage tanks.

The availability of the evaporator condensate together with the steam condensate ensures that there is a surplus of 14,000 gallons per hour of hot water after the boiler feedwater requirements are satisfied.

This excess condensate at a temperature of 55°C is used to provide a hot water ring main system which is circulated at 60 p.s.i.g. around the plant by 2 - 10,000 g.p.h. pumps. Twenty hot water hoses are fed from this system and these hoses are used for general cleaning.

The quantity of steam saved by using this condensate instead of live steam and water amounts to 12 million pounds of steam annually. This is equivalent to a saving of 94,000 gallons of oil or in monetary terms at current oil costs £65,800. This is quite an attractive saving when we consider that the capital cost of installing the system was £33,000.

**Insulation of steam and chilled water mains**

Bearing in mind that every square foot of unlagged steam pipe wastes approximately 50 gallons of oil per annum, all steam, condensate and chilled water pipelines have been suitably insulated to the economic thickness relevant to the period of the installation. Any pipeline through which heat loss (or gain) could be expensive has been insulated.

**Maintenance of consistently efficient boiler operation**

The collection and recirculation of the condensate from the steam distribution system gives a boiler feedwater temperature of 170°F. This improved the previous feedwater temperature such that a 4% fuel

saving wash achieved, representing an annual saving of 90,000 gallons of fuel oil or £63,000 at current costs.

The high level of condensate return is also reflected in the cleanliness of the boiler water and lack of scale formation on the water side of the heat transfer surfaces within the boiler. This ensures optimum heat transfer and minimal sludge formation, which in turn ensures that boiler blowdown is limited to one short burst per day.

All boilers have steam and oil flow meters so that overall efficiency can be continuously monitored through daily readings and recordings.

Boiler flue gases are also continuously analysed through CO<sub>2</sub> and temperature instruments and the results are recorded for assessment as necessary.

Regular tests are also carried out by the I.I.R.S. in order to access the accuracy of the metering systems used.

**Pipeline maintenance and leak prevention**

Wherever possible all steam lines are inside buildings for protection. Idle lines can be isolated so that steam is not wasted in the non load situation through condensation in cold lines. Leaking valves and flanges can be repaired within these zones thus eliminating the necessity of shutting down the plant.

Steam traps and other equipment are regularly checked and any inordinate amounts of flash steam are traced to source and eliminated as they arise.

Faulty traps are particularly expensive, it has been shown that a ¼" leak wastes approximately 2.5 million pounds of steam per annum or 20,000 gallons of oil (or £14,000 at current oil costs). Quantification of these losses in this way indicate the seriousness of the problem and the urgency with which costly leaks should be repaired as part of our maintenance policy.

**Measurement of all steam and electricity usage in all plants**

At the outset of this energy conservation programme it was realised that quantifiable savings could only be achieved through measured reduction in primary energy use. The Company policy was therefore to install metering systems to monitor all existing steam and electrical loads.

In pursuance of this policy in the Dungarvan plant we have installed over 60 flow meters, monitoring fuel oil, steam and electricity. Through this energy control system, incoming primary energy is compared with boiler output and plant consumption.

Any deviations from the trends in unit energy usage or consumption per ton of product are immediately highlighted and it is then possible to take whatever action is required to define the problem and to rectify it with the minimum energy and financial cost.

This system also enables the Company to accurately cost the value of the usable form of energy (steam) and to prepare meaningful annual revenue budgets.

**General good housekeeping measures to reduce wastage**

The active implementation of this policy ensures that areas of wastage are highlighted on an on-going basis. A typical example is the use of steam and water hoses. These are used for

general cleaning in certain areas and in some parts of the plant wash up. In such instances the base of these steam pipes has been reduced from 1" to ¼" using an orifice within the fitting. This has the immediate effect of reducing the steam flow rate from 1200 Lbs./hr. to 500 Lbs./hr.

Great achievements have been reached in reducing losses at the start up and shut down times in the plants. This is not a once off situation where the reduction in energy usage can be achieved and neglected thereafter. It is an on-going process and requires on-going attention.

**Some views on Energy Management**

The Energy Manager has a difficult task and the nature of the feedback which he provides for plant or production Managers is seldom very flattering.

During the period 1974 to 1978 it is clear from our achievements in the area of energy control that our Energy Manager did some Trojan

work.

It is true that much of this achievement is due to the commitment and drive of the Energy Manager and that he did not always receive the appropriate level of support from Management over this period due to their prior commitments in the areas of development and expansion at the time.

Due to the current exorbitant cost of energy in our Industry it is no longer feasible to allow the responsibility for Energy Management on the shoulders of one man.

Energy Management is now a team effort and the team includes every man involved in the process from the Senior Executive to the man washing the floors.

**The Importance of Effective Communication in Achieving Results**

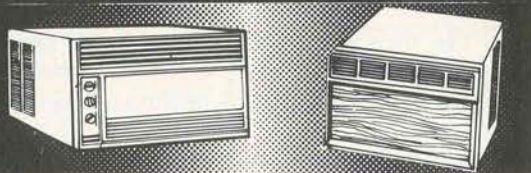
While it is true to say that energy unit costs have been monitored closely for each plant and reviewed at weekly meetings of production personnel



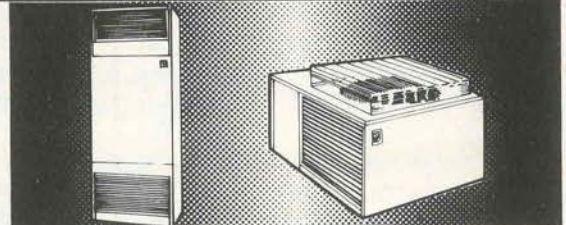
**Hall-Thermotank Ireland Limited**

**Refrigeration and Air Conditioning**

**QUALITAIR AIR CONDITIONING EQUIPMENT**



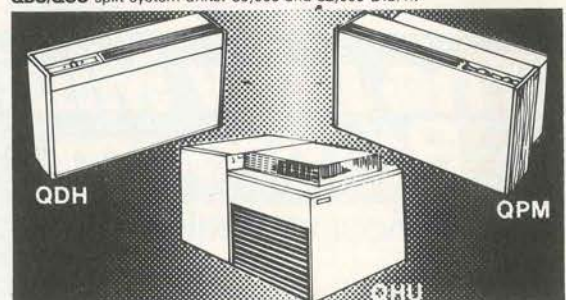
**QRU/QWR** window/wall mounting units. 9,500 - 23,000 Btu/h.



**QBU/QCU** split system units. 50,000 and 82,000 Btu/h.



**QSS** split units. 9,000 - 24,000 Btu/h.  
**QCM** ceiling mounted split units. 18,500 - 24,000 Btu/h.  
**QKK** cool storage units. 7,500 - 16,000 Btu/h  
 Add on units for fitting to QSS and QPM models.



**QDH** dehumidifier  
**QHU** roof mounted units. 54,000 and 75,500 Btu/h  
**QPM** through wall mounting units. 10,000 and 12,700 Btu/h.

Exclusive Irish Distributor

**Hall-Thermotank Ireland Limited**

Hall House, Main Street, Rathcoole, Co. Dublin. Tel: (01) 580311 Telex: 30943

**ENERGY MANAGEMENT IN THE DAIRY INDUSTRY**

since 1974, over the past 2 years a more positive and aggressive approach has been taken on energy control.

**The Energy Committee**

In 1979 we formed our first Energy Committee which comprised of The Energy Manager, The Technical Manager, The Manager of the Division, The Maintenance Manager and The Energy Consultant.

The meetings are held on a Monthly basis and coincide with the "trouble shooting" visits of the Consultant.

At these meetings both long term projects and short term matters are considered and decisions are taken on action programmes.

**The Staff Meetings**

Decisions taken at the Energy Committee meetings are discussed under the appropriate heading at the weekly Staff Meetings. Here again discussions take place on the proposed action. The decisions taken are minuted and reviewed at subsequent meetings.

Further communication on these matters is achieved through the plant supervisors and the plant operators with much emphasis on regular and meaningful feedback.

An interesting example of this system in action arose during the November '81 February '82 period.

The Energy Committee had taken a decision to make the greatest saving possible by ensuring that plants are not run during the 5 p.m. - 7 p.m. critical period. When this matter was discussed at the Production Staff Meeting the Plant Managers felt that it was totally impractical to have the plants down between 5 p.m. and 7 p.m. for a variety of reasons. We then prevailed on them to try out the proposed system for one week when we could again re-examine the situation.

**TABLE 2**

<b>Better monitoring and control of solids during evaporation</b>	<b>£70,000/annum</b>
<b>Scheduled cleaning of evaporators</b>	<b>- £42,000/annum</b>
<b>Two stage drying</b>	<b>- £112,000/annum</b>
<b>Extra vigilance in ensuring insulation of steam and chilled water mains</b>	<b>- £50,000/annum</b>
<b>Use of excess condensate</b>	<b>- £185,000/annum</b>
<b>Prompt maintenance of all steam leaks</b>	<b>- £100,000/annum</b>

ion.

By the end of the first week these people were scarcely aware of the change in the operation.

We then circulated details of the daily power utilisation and also indicated the potential savings of continuing to operate in this fashion. At one stage this feed back was neglected for a period and a notable increase in power utilisation was apparent.

On resuming the circulation of this information utilisation returned to an acceptable level.

We estimate that this effort netted a total saving of approximately £20,000.

We also ensure the involvement of all plant managers by introducing the consultant to our production staff meetings at approximately six month intervals.

It is true to say that the Consultant when reporting on his "trouble shooting" inspections does not "pull any punches" and consequently it is no surprise that tension was at a high level at the first meeting at which he attended. However, when the "role of

the Consultant" was clarified a great team spirit and two way flow of information and suggestions gradually developed and this encouraging trend has continued.

**CONCLUSION**

Waterford Co-Op Society through an active and encouraging Management organisation has managed to reduce its primary fuel utilisation over a 6 year period of expansion.

At current Energy costs this in monetary terms amounts to a saving in excess of £2 million per annum. Energy conservation projects under current review indicate that potential still exists to further reduce our primary fuel input while maintaining current levels of production.

We wish to acknowledge the support and assistance which we have received through the years from the staff of the I.I.R.S. and Integrated Energy Systems. Without their help, it is clear, that we would not have achieved our present levels of energy efficiency.

# The new Minifan-Generation for Bathroom and WC

The most versatile range for duct-wall-, and window-mounting

**GKN AUTOPARTS (I) LTD**  
Camac Close, Inchicore  
Dublin 8.  
Telephone (01) 781700.







- Exemplary Design in attractive colours fitting in harmony with bathroom and WC.
- Electric Inside Closure Shutter closing tightly and without rattling.
- Built-In Over Run Timer
- Short Depth Construction
- Small Diameter to slide into 100mm Ø pipes.
- High Performance & low sound two ranges with 95 & 130 m<sup>3</sup>/h.



## INSTITUTES AND ASSOCIATIONS

The following is a list of names, addresses and telephone numbers of associations and professional institutions in the Republic of Ireland connected with the building services industry. Due to pressure on space we will not be publishing certain lists of members until later issues.

### **A n C O**

P.O. Box 456, Baggot Court, 27/33 Upper Baggot Street, Dublin 4  
685777

### **Association of Consulting Engineers of Ireland (ACEI)**

63 Haddington Road, Dublin 4  
600374

### **An Foras Forbartha**

St. Martin's House, Waterloo Road, Dublin 4  
764211 Telex 30846

### **The Building Information Centre**

4 Northbrook Road, Dublin 6  
977487

### **Construction Industry Federation**

9 Leeson Park, Dublin 6  
977487

#### Regional Offices:

Riverview House, Montenotte, Cork

Contact: Mr. J. O'Brien (021) 507161

Main Street, Letterkenny, Co. Donegal

Contact: Mr. D. MacLochlainn, Letterkenny 88

15 Earl Street, Dundalk, Co. Louth

Contact: Mr. J. M. Kearney (042) 34017

"Menapia", Dublin Road, Naas, Co. Kildare

Contact: Mr. P. Kelly (045) 97394

Mainguard Street, Galway

Contact: Mr. J. F. Fitzgerald (091) 64515

88 O'Connell Street, Limerick

Contact: Mr. M. Connelly (061) 44622

3 Garden Vale, Athlone, Co. Westmeath

Contact: Russell Brennan & Co. (0902) 2449

The Mall, Castlebar, Co. Mayo

Contact: Mr. J. J. Burke Castlebar 136

Ballycar House, Newtown, Co. Waterford

Contact: Mr M. Hanrahan (051) 4858

### **Chartered Institution of Building Services**

Hon. Sec: Larry Kane

Irish Estates (Management) Ltd. Mespil Estate, Sussex Road, Dublin 4

688278

### **Energy Conservation and District Heating Association of Ireland**

22 Clyde Road, Ballsbridge, Dublin 4  
684341

### **Energy Management Association**

National Organiser: Harry Pattison  
IIRS, Ballymun Road, Dublin 9  
370101

### **Fire Industry Association of Ireland**

78D Lagan Road, Dublin Industrial Estate, Dublin 9  
265911

### **Institute of Domestic Heating Engineers**

Assistant Secretary: Katrina McTernan  
18 Arranleigh Vale, Rathfarham, Dublin 16  
945257

### **Insulating Contractors Association**

9 Leeson Park, Dublin 6  
977487

### **Institute of Industrial Engineers**

I.P.C. House, Shelbourne Road, Ballsbridge, Dublin 4  
686244

### **Institute of Engineers of Ireland**

22 Clyde Road, Dublin 4  
684341

### **Institute for Industrial Research and Standards (IIRS)**

Ballymun Road, Dublin 9  
370101 Telex 5449

Regional office: Monaghan Road, Cork

(021) 24341, 504954 Telex 6078

### **Mechanical Engineering Trades Association Ltd.**

9 Leeson Park, Dublin 6  
977487

### **The Mechanical Engineering and Building Services Contractors Association**

9 Leeson Park, Dublin 6  
977487

### **National Board for Science & Technology**

Shelbourne House, Shelbourne Rd., Dublin 4  
683311

### **Solar Energy Society of Ireland**

c/o School of Architecture, University College, Earlsfort Terrace, Dublin 2  
752116 Telex 5278 Library: 370101 Telex 5449

# BIRTHDAY GREETINGS

Irish H & V News,  
5/7 Main Street,  
Blackrock,  
DUBLIN.



"Naisetra"  
Old Naas Road,  
DUBLIN 12.

25th March 1982.

Dear Sirs,

On the 21st Anniversary of its publication it gives me great pleasure to congratulate the Irish H & V News magazine.

I remember a time so long ago hearing that a new magazine was being published from an office in Hawkins Street, Dublin, called the Irish Plumbing & Heating Engineer, and later noted its change of title to Irish H & V News and its change of address to Blackrock. Over the years, it has been an invaluable source of information, guideline, and technical advice to all its readers. It has provided a forum for discussions of various topics pertaining to the heating trade.

Over the years it has been presented and guided by Mr. Gerard Murphy, Gerry, an old friend of mine in the I.D.H.E. and was for many years our Public Relations Officer. This happy position helped the I.D.H.E. in its early years, by publishing its aims, objectives, and giving news of the various events in which we were engaged. As we all know Gerry has progressed in fresh pastures but his colleagues are still carrying on the good work which he instituted.

As Chairman of the I.D.H.E. it only remains for me to wish Irish H & V News every success for the future.

Yours sincerely,  
I.D.H.E.  
W. V. Madigan  
Chairman.

The Chartered Institution  
of Building Services  
Republic of Ireland  
Branch



Mr Ray Loughran,  
H & V News.

Dear Mr Loughran:

I would like on behalf of the CIBS in the Republic of Ireland to congratulate you on the publication of your special 21st Anniversary edition.

This occasion seems appropriate to ask you to inform your readers that approval has been given to the establishment of a degree course in building services engineering in Bolton Street in conjunction with Trinity College Dublin. To ensure the success of this course I would ask all those concerned in the Building Services Industry to support this course.

The CIBS are also gratified to see such active participation of the students in the affairs of the Institution. 17 papers (all of a very high standard) were submitted for the CIBS Annual Students Awards. Three papers were read at the Students Evening at 22 Clyde Road recently, which the prizes were presented, details of the prize winners to be published later.

With very best wishes for the future.

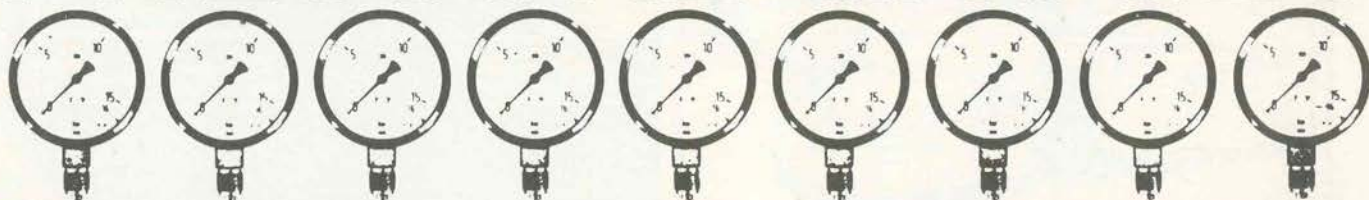
Yours sincerely,  
Eamon O'Brien  
Chairman — CIBS Republic of Ireland



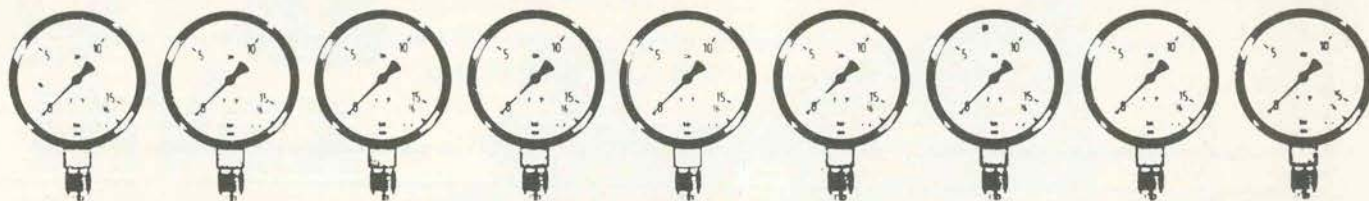
**WIKA**

the most purchased gauge in Europe

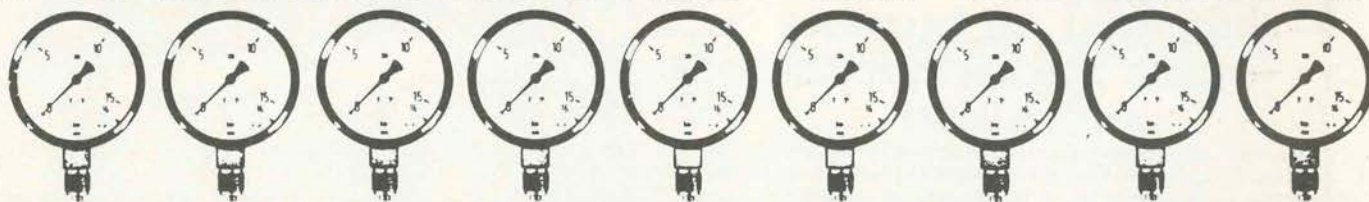
# PRESSURE GAUGES



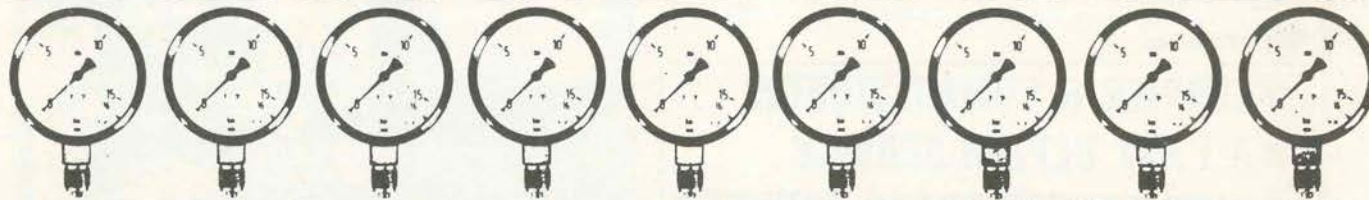
# PRESSURE GAUGES



# PRESSURE GAUGES



# PRESSURE GAUGES



**INDUSTRIAL INSTRUMENTS LTD**  
— THE INSTRUMENT PEOPLE

6 Herbert Place,  
Dublin 2.  
Tel: (01) 761691  
Telex: 24789

Kilcoolishal,  
Little Island,  
Cork.  
Tel: (021) 935224  
Telex: 75320

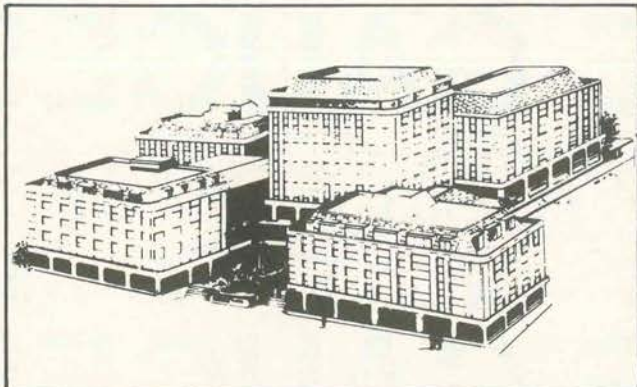
# S.M.C.

## Air Conditioning

SPECIALISTS IN  
HEATING, REFRIGERATION,  
AND AIR CONDITIONING  
SYSTEMS

**WHITEHALL HOUSE, MAIN ST., CASTLEKNOCK,  
CO. DUBLIN. TELEPHONE DUBLIN 210587/210759.**

*The largest team of qualified technicians for commissioning and maintenance of air conditioning systems in Ireland.*



Headquarters Irish Life Building, Dublin



Allied Irish Banks Headquarters, Ballsbridge, Dublin

**Two of the largest fully air conditioning office complexes in Ireland. Both contracts were awarded to S.M.C. Air Conditioning.**

Now appointed sole Irish distributors for **YORK** DIVISION OF BORG-WARNER LIMITED **BORG-WARNER**  air conditioning and refrigeration equipment.

# SUPERJET

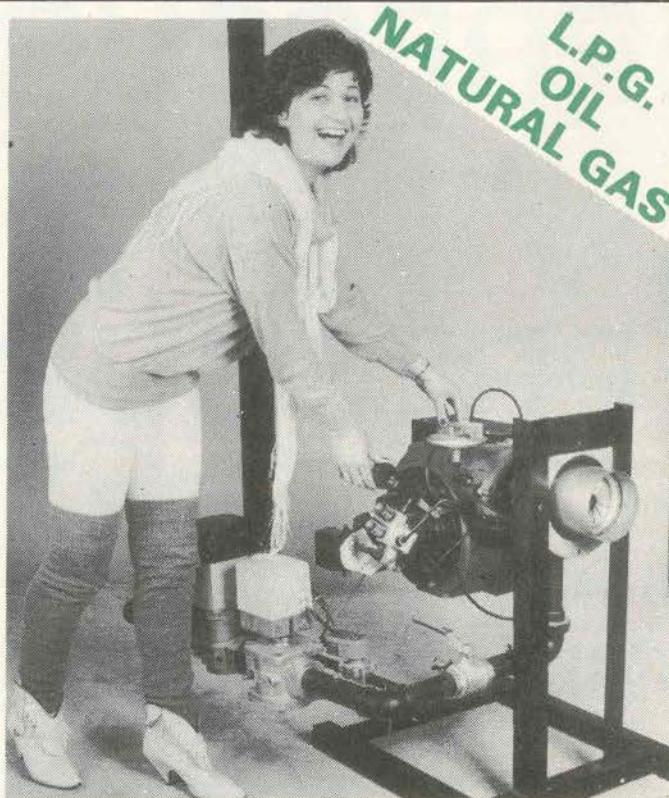
## dual fuel oil burners made and serviced in Ireland



Superjet are now manufacturing in Ireland a range of gas/oil burners, both industrial and domestic in a range from 50,000 BTU's to 15,000,000 BTU's. These units are available ex stock and are backed up by a proven commissioning and service network.

Our trade counter holds complete spares for industrial and domestic and thus offers a valuable service to the industry. Spares availability includes E.G. Probes and control boxes; Gas valves • U.V. cells and fans • Electric motors • Pipework and fittings, etc.

- SERVICE & COMMISSIONING
- A FAST REPAIR SERVICE
- CITY CENTRE TRADE COUNTER
- SPARES & FITTINGS, ETC.
- ANNUAL SERVICE
- CONTRACTS ON REQUEST.



**A LONG AWAITED SERVICE TO THE INDUSTRY**

# SUPERJET IRELAND LTD.

UNIT 22, TEMPLE LANE, HILL STREET, OFF GARDINER STREET, DUBLIN 1. TELEPHONE: 742855.

# EXPOCLIMA Hevac 82

H&V News have again organised a special trip to the Hevac 82 exhibition in Birmingham. The show will run from the 24th to the 28th of May inclusive and these are the special rates negotiated by us:

### Scheme 1

#### Holiday Inn Hotel

Two nights bed and breakfast for either the 24/25th May or the 26/27th May.

Price to include air fare and B/B at hotel. . . . IR£179.00  
Single room supplement. . . . . IR£40.00 extra

### Scheme 2

#### Grand Hotel

Two nights bed and breakfast for either 25/25th May or 27/28 May.

Price to include air fare and B/B at hotel. . . . IR£169.00  
Single room supplement. . . . . IR£36.00

To book or for further information contact Victor Gibson of H&V News at (01) 885001, 5/7 Main Street, Blackrock, Co. Dublin or Bernard Healy or Pauline Thompson of Abbey Travel Tel: (01) 724188.

# '83 IhVex



● Simmons Court Exhibition Complex, Royal Dublin Society, Ballsbridge, Dublin.

Ireland's building services exhibition which includes Heating & Ventilating/Air Conditioning/Fuel Conservation/Environmental Engineering/Pollution Control/Refrigeration/Sanitaryware/Plumbing Equipment.

As we progress through the decade the building services industry faces challenging times. But all is not doom and gloom as the coming of an independent fuel supply, natural gas, and the change over by industry to coal has created projects that would never have otherwise began. Energy conservation continues to be of major importance to the industry and is an area of growth both for installation and technological development. Never before has there been such a need for energy conscious controls and industry in general is looking to the building services industry to fill that need.

With this background IhVex '83, Ireland's only major national building services specialist exhibition, will be the opportunity for the industry to show that it is prepared to meet the challenges ahead. The success of IhVex '81 is proof enough that when it comes to getting

the message across to the greatest number of engineers, specifiers, contractors, energy managers and the like, the IhVex formula is the successful one.

### Venue

Simmons Court Exhibition Complex, Royal Dublin Society, Ballsbridge, Dublin 4.

### Dates

Tuesday, 15 February, 1983; Wednesday, 16 February, 1983; Thursday, 17 February, 1983.

### Open Time

Tuesday 12 noon - 8 p.m.; Wednesday 12 noon - 8 p.m.; Thursday 12 noon - 8 p.m.

### Admission

Trade visitors by invitation.

For full exhibition details contact: ITTEX, Irish Trade & Technical Exhibitions (ITTEX) Ltd., 5/7 Main Street, Blackrock, Co. Dublin, Ireland. Tel: (01) 885001.

*Sponsored by Irish Heating & Ventilating News*



by Chrisy Kane, Press Officer

## Examination Time at Bolton Street

### EDUCATION

On the educational front, the on-going I.D.H.E. diploma courses at Bolton Street College of Technology are coming to examination time once again. The MIDHE full membership course will take the first section examination after having completed one year of the two year course. Best wishes to those who have stayed with it so far and continued success on the final year.

The Associate Membership (AMIDHE) classes will also be taking examinations the same time i.e. Monday 17th, Tuesday 18th and Thursday 20th May. The Associate Grade of the Institute is proving over the years to be of immense value to those who did the course and now with the introduction of full membership grade this can only increase the valuable knowledge already acquired and help also to promote more professionalism, ability and status within the institute to the mutual benefit of all concerned and to be recognised by Governmental and other professional institutes within the country.

For those interested in becoming Associates and or full members, (watch out for further reminders) for the moment enrolments will be taking place next September at Bolton St. School of Technology. Times and exact dates will be issued in due course, alternatively in the meantime ring our Assistant Secretary Katrina — 945257 for information about the courses.

### VISIT TO THERMO HOUSE

IDHE members enjoyed a pleasant and relaxing even-

ing at "Thermo House", Berkeley St. recently, courtesy of Michael Curtin and Michael Vaughan. A simple introduction to what Thermo House is all about, was aimed initially at the consumer in the proper use and care particularly of solid fuel cookers. Apart from displaying the Wamsler and Tirolia solid fuel cookers in the showroom along with more recent additions in the line of cooking utensils especially for use with solid fuel cooking appliances has now also introduced gas cookers manufactured in Ireland aimed at the future natural gas market potential.

However, to enhance the original idea of solid fuel cooking care and proper use led to the very successful actress of "The Riordans" fame, Biddy-White Lennon, better known as Maggie to demonstrate her cooking skills using the Wamsler solid fuel cooker set upstairs in a well laid out kitchen cum classroom, blackboard and all.

This has proved to be very successful since it was started and now Biddy has demonstrated cooking various recipes to interested

groups on a regular basis for months now. This time however, she was confronted with people from the trade but nevertheless she showed that with her demonstration of cooking turkey dishes, onion casserole etc. (the best way to a man's hear was through his stomach).

This is where Michael Curtin's use of the blackboard shows the most crucial point of flue installation, i.e. immediately off the cooker outlet. A very high percentage of cooker problems are mainly due to this particular point not being adhered to the manufacturers recommendation of flue requirements and of course the current draft building regulations.

Michael Vaughan expressed that with proper legislation from the Government Dept. concerned to overcome the bad installation and usual "cowboy" activity we could achieve the proper standards despite any efforts made to date, standards are there already by those who care, but until we aim at the right person in the Ministerial position of Government to whom they can instruct and introduce legislation, and not until then, can this be brought about then eliminate the unregistered "cowboy".

It was interesting and encouraging to hear Michael mentioning that Thermo House received quite a lot of calls from customers with problems with their cookers and even though they were not Wamsler or Tirolia cookers they still gave advice and in some cases even called out to

these customers to see if they could sort out the problem or identify what was wrong. The policy here being that it didn't matter what solid fuel cooker one had, if it gave problems (irrespective of the cause of the problems) then this person would be put off solid fuel cookers altogether, which in turn relates to all solid fuel cookers getting the knock, including Wamsler and Tirolia. All enjoyed a pleasant evening, thanks to all who came along and of course to all the personnel/staff of Thermo House.

### VISIT TO WALKER AIR CONDITIONING LTD.

As part of the membership course, (MIDHE) in Bolton St., the students were taken to the premises of Walker Air Conditioning Ltd. recently. WAC is Ireland's largest air conditioning company and carry a large stock of AC and refrigeration components which were on display to the students. Fault finding in refrigeration systems was discussed by Gary Holmes, who is the service manager with WAC. This field trip was the most important and interesting visit of the year as the students could see at first hand the equipment that went with the theory they have been studying in the college.

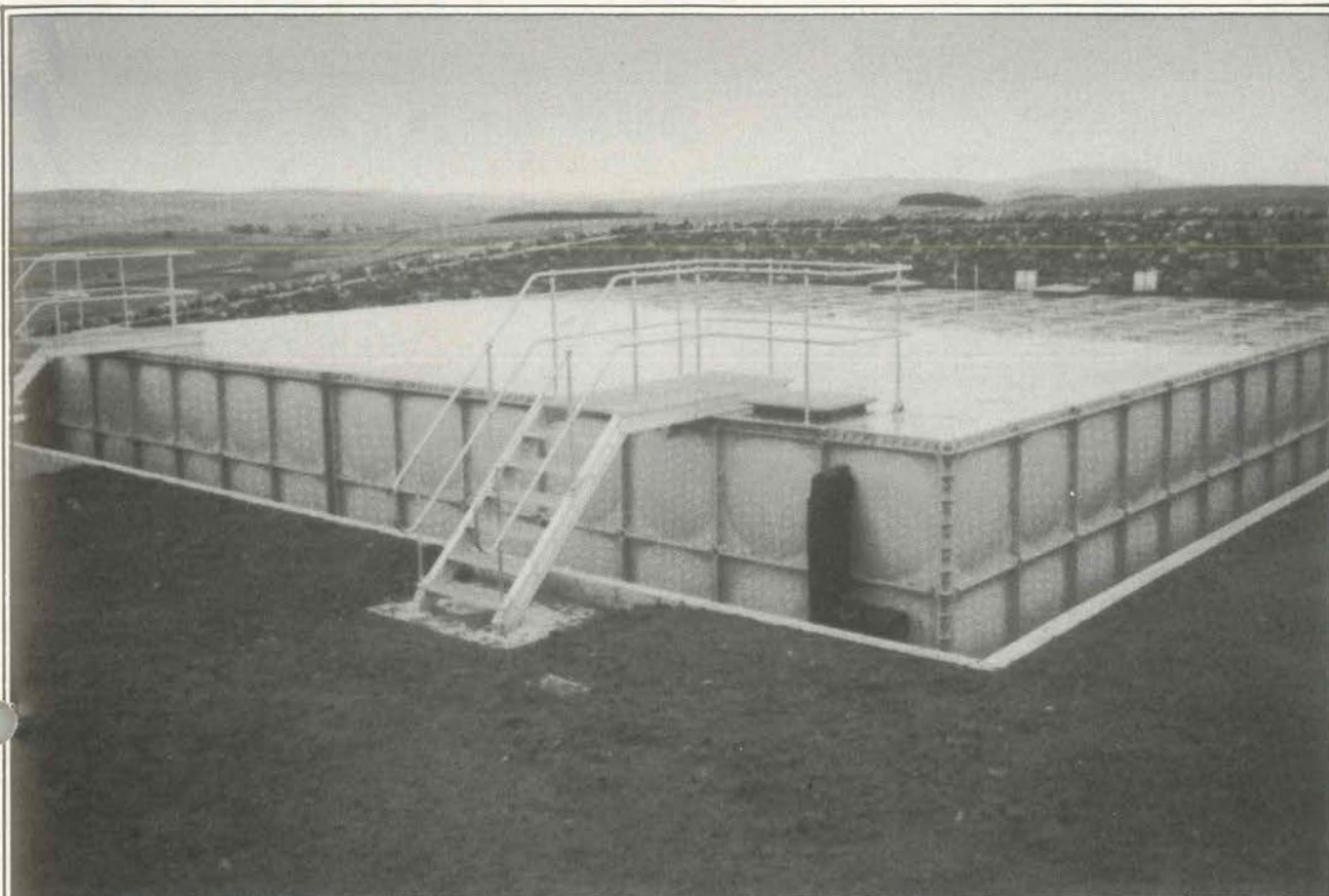
The IDHE committee, the students and lecturers on the course, Tom Dinnigan, Sean Costello and Ray Loughran wish to express their sincere thanks to Walker Air Conditioning Ltd. and especially to Gary Holmes who gave most generously of his time, for providing the facilities and making the visit very worth while.

### GOLF

The IDHE Golf Outing this year takes place at Elm Park Golf Club on Tuesday 11th May. Teeing off time to be confirmed, those interested watch out for further notice, members will be notified by post, booking through out Chairman Victor Madigan or Assistant Secretary Katrina McTernan, telephone 945257.

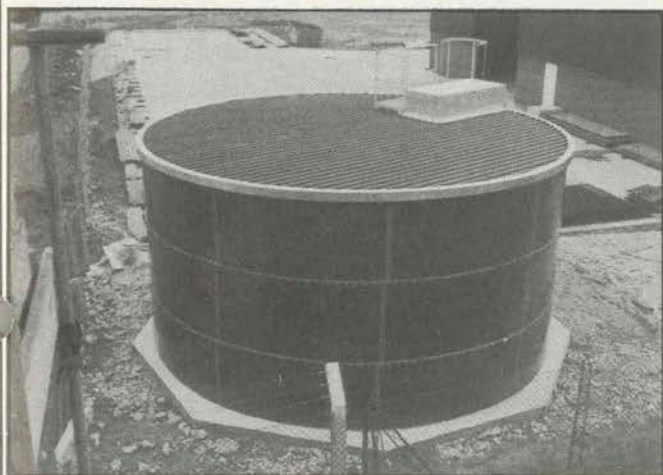


● (Left to right): Ms. Biddy White-Lennon; Mr. Michael Curtin, General Manager, Thermo-House and Mr. Michael Vaughan, Managing Director, Michael Vaughan Trading in Thermo-House.



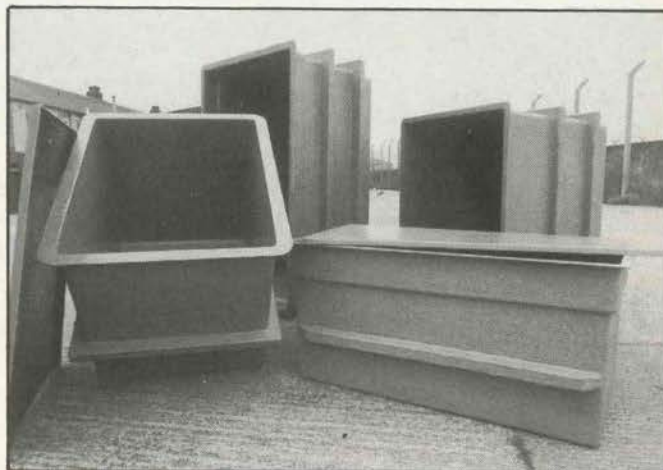
**NEI**

**N.E.I. Hydrostor G.R.P. Sectional Tank Capacities from 1000 Litres to 4.5 Million Litres.**



**V**

**Vulcan Vitreous Enamelled and Galvanised Tanks.  
F.O.C. & F.M. Approved Capacities 10 Cubic  
Metres — 5000 Cubic Metres.**



**dp**

**Decca Plastics One Piece G.R.P. Tanks Ex. Stock.  
Capacities 100 — 2000 Gallons Corresponding to  
Galvanised Tanks.**

*Available from Sole Irish Agents:-*

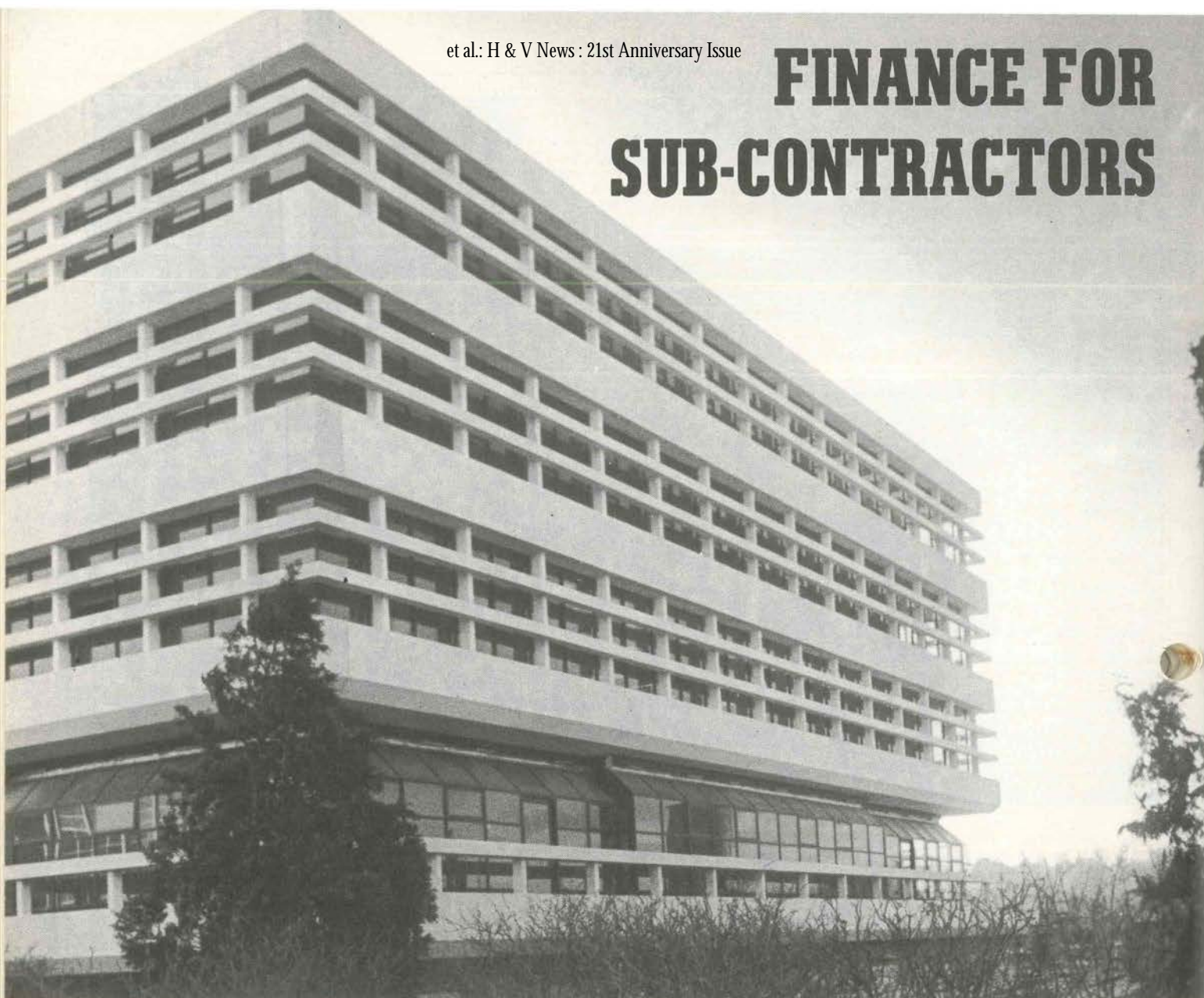
**STI**  
**LTD.**

**STORAGE TANKS OF IRELAND**

COOLOCK INDUSTRIAL ESTATE, DUBLIN 5.

TEL: 450135 TELEX: 24311

# FINANCE FOR SUB-CONTRACTORS



Over a three month period in the summer of 1980 we ran what must have been one of the most popular series of articles of the last few years. The title was "Finance for Sub-Contractors" and the author was Robert McClean, Account and Services Manager, Rotary Group. The series touched some of the most vital areas in sub-contracting, including, getting paid, cost control on individual contracts and control of overheads and profits.

Since we published that series we have had numerous requests for re-prints and so in an effort to meet the demand we reprint the entire series in this our special 21st issue.

## Getting Paid

The success or failure of any growing company in the construction industry, and in particular subcontracting, depends mainly on the operation and control of its cash flow. This function within a small company is not given the priority it deserves, as most

individuals having formed their business from a small capital, concentrate on completing the work, satisfying the architect, and ignoring the whole idea of it all — getting paid.

This attitude by small companies is only to be expected as the self appoin-

ted directors have a technical background and have progressed up the ladder from site training commencing with a four or five year apprenticeship, a period of time as tradesman, a foreman, a supervisor and then possibly some training in the control of material

and labour requirements for various contracts.

Having reached this stage of their trade they decide to begin their own business having gained valuable knowledge in how to start, control and complete a contract and with their experience this pre-



## FINANCE FOR SUB-CONTRACTORS

sents no problems whatsoever. However, a close look at the success rate of small contracting firms started this way reveals a small percentage of actual progress and in fact most stay at the level they originally started, showing no growth at all.

The main cause of this is the lack of finance or the lack of knowledge, or interest in controlling the financial activities of the operation. This is due to claims not being submitted on time, not being pursued through the various stages and therefore payments not being received. The sub-contractors money is therefore being used by others while he pays overdraft interest to banks. These charges absorb all profit, leaving him without finance.

### INTERIM CLAIMS:

Claims are normally submitted monthly but on small contracts or short term contracts it is advisable to issue them at shorter intervals. Where direct contracts are involved payment will normally be made when due but when dealing with consultants, quantity surveyors, architects and builders, it is important to follow up each stage of your claim until the builder actually writes the cheque.

The preparation of monthly claims is also very important in ensuring payment and the example shown in Figure 1 should be used on all claims submitted. On receiving an order for a contract, obtain the name of the main contractor, the architect, the quan-

Work	Done	to	Date
<b>Fig 1 - INTERIM CLAIM</b>			
Contract -----			
A		B	
Contract Details to Date		Work Done to Date	
1. Tender Sum Nett	10,000	4,000	
2. Extras	1,000	400	
3. Increased Costs			
Material	500	500	
4. Increased Costs			
Labour	500	500	
<b>TOTAL NETT</b>	<b>12,000</b>	<b>5,400</b>	
Builders Discount	600	300	
<b>TOTAL GROSS</b>	<b>12,600</b>	<b>5,700</b>	
V.A.T.	378	170	
<b>TOTALS</b>	<b>12,978</b>	<b>5,870</b>	

tity surveyor and the consultant. As the builder will already have been issuing monthly claims, find out what dates he has agreed for the submitting of claims and always prepare your claim at least a week before that date. It is also advisable to forward copies to the consultant, architect and quantity surveyor.

Note figure 1: (A) On each monthly claim the figures on items 2, 3, 4 can be updated, thus showing all concerned the present value to date of the contract and therefore not waiting until final account stage to claim for extras and increased costs.

On extras it is important to establish a price when this work is requested and confirm the amount with the consultant/architect without delay. On increased costs, details should be submitted with each claim

and kept up to date as frequently as possible.

(B) This section is the whole basis of your cash flow. On claiming for work completed on the original tender sum you should refer to your estimate, and calculate the percentage of work completed as priced, and also include for material on site unfixed and also material expected on site within say four days of the interim claim.

The value of extras actually completed should be detailed and this can be calculated from the amount of extras requested. Increased labour costs and material will be the same figure as in section A.

The amount of paperwork involved in all this would appear to be excessive but if you examine it carefully and keep your records up to date the time involved should be minimal.

Having prepared and presented your interim claims in this format you have given all concerned all the facts and figures required and there is no reason whatsoever why the claims should not be certified and paid in full. Having obtained a recommendation from the consultant, you should follow up on the following stages and ensure that when the builder receives his payment certificates you are included for the full amount claimed.

Payment from the builder should follow provided you keep in touch and establish with him when in fact he expects payment from the client.

Having received payment your contract should be at least paying for itself and your profits, if any, are not being absorbed by bank overdraft interest. On a number of contracts the same control could result in your having a surplus cash situation in which to (a) increase your working capital or (b) negotiate with suppliers on the possibility of obtaining cash settlement discounts and therefore increasing the profits of the company. In the long term, a company can only be successful and ensure continuity by making profits.

In the short term however, a company can make profit but still be forced into liquidation because of an adverse cash flow (overtraded situation). Finally, if you have received your cash on a regular basis you are unlikely to become the victim of a bankrupt builder.

## Cost Control on Individual Contracts

The design and control of systems is a job for a man who can think in both financial and physical terms and who understands the implications of what he is proposing in relation to his company. In controlling the running of his contracts, he must use the base tender

figures and quantities included in the make-up of his original price.

Ordering the correct materials and recruiting the required labour will be automatic but to ensure that the contract achieves a profit he must monitor his costs as they occur and

take the necessary steps to correct any difference shown. Costs on contracts should be shown individually and, depending on the size of the job, this simple exercise can be done and easily controlled using the example shown in Figure 1.

In this example you can

see from month to month your costs in both labour and material accumulating and, by examining your actual costings with your original tender figures, you can tell at a glance the stage of a contract to the given date. This control also gives warning if your

## FINANCE FOR SUB-CONTRACTORS

labour costs are out of line with your tender and enables you to correct the situation while the contract is in progress. Without this you could in fact be losing money on the contract without knowing, only to find out at the end of the job when it is too late.

The same applies to the material costings which could be over the tender amount allowed, and with this control you can calculate what percentage of the contract has been completed on the material side and estimate the value of material needed to complete the job. If it is too high or too low you can take the necessary action to cut your losses or increase your profits.

Again the amount of time consumed in implementing this control is minimal compared with the amount of time you will spend trying to find out what went wrong if disaster occurs.

Your claims, cash and cost control can all be applied to this one form, and by building up a library of completed contracts you will have a history of various jobs showing you the following:

- (1) Was this type of job profitable or disastrous?
- (2) Was the profit made on

Figure 1 ORIGINAL TENDER						
Date	Labour	Material	Profit	Labour	Material	Extras
June 79	7,000	11,000	2,000	1,000	1,000	1,000

ACTUAL COSTS INCURRED						
Date	Claims	Cash	Labour	Material	Total	Profit
July	-	-	1,000	2,000	3,000	
Aug.	4,000		2,000	3,000	5,000	
Total to date	4,000		3,000	5,000	8,000	
Sept.	6,000	4,000	1,000	1,000	2,000	
Total to date	10,000	4,000	4,000	6,000	10,000	
Oct.	7,000	6,000	2,000	4,000	6,000	
Total to date	17,000	10,000	6,000	10,000	16,000	
Nov.	6,000	7,000	1,000	1,000	2,000	
Total to date	23,000	17,000	7,000	11,000	18,000	
Dec.	-	6,000	-	1,000	1,000	
Totals	23,000	23,000	7,000	12,000	19,000	

material?

- (3) Were the losses made on material?
- (4) Was the profit made on labour?
- (5) Were the losses made on labour?
- (6) Did this contract cause any labour problems?
- (7) Was the architect/consultant reasonable?
- (8) Was payment certificate issued on time?
- (9) Did the builder pay you on time?

Various other points are

available from this control but most important is that if you have a series of the same type of job you can adjust your estimate if necessary to allow for the changes which occurred during the job. You can also become more competitive in tendering for larger contracts by studying the amount of increased costs, variations and extras, labour savings etc. that occurred.

Finally, all notes relating

to the estimate of each contract should be studied carefully in order to obtain the maximum discounts from your suppliers for the purchase of materials and to try to improve on the prices tendered for by way of bulk order buying. Labour should also be studied to achieve the maximum efficiency of your operatives and to plan the various stages of the job and control the workforce necessary.

## Control of Overheads and Profits

As stated previously, the general aim or objective of all business organisations is to make a profit. We can define company profit quite simply by saying it is the amount of money remaining in the company's hands after it has met all of the costs of operation.

Having implemented the necessary controls on contract costs, claims and cash flow, companies must not forget that the operating costs of the organisation must also be controlled in the same manner. The true profit situation of any company can only be known when all costings for labour and material and

overheads are taken into account.

A very simple system of control can ensure that your profits are not absorbed by your overheads and by installing the method on Schedule 3 you can obtain a vast amount of knowledge of the operation of your company from your administration end.

The basic overheads required for all companies should reflect on the size of the business and the long or short term objective on future growth. By calculating the amount of money required to carry out a certain turnover in a years trading, a base percentage

can be used to determine costs for carrying out an increased turnover. An ex-

ample of this is shown in Table 1.

Year	Turnover	Overheads	Percentage
1970	£40,000	£4,800	12%
1971	£50,000	£5,000	10%
1972	£60,000	£6,000	10%

Table 1

Tender Amount Nett	say	£10,000
Amount required to cover overheads	say 10%	£1,000

Table 2

## FINANCE FOR SUB-CONTRACTORS

SCHEDULE 3 — FIGURE 1

### OVERHEAD CONTROL FOR 1973

	Total Cost 1972	Budget Cost 1973	ACTUAL COSTS 1973													
			Jan	Feb	Mar	Apr	May	Jun	Jul	Aug	Sep	Oct	Nov	Dec	Total	
Bank Interest	2,600	3,000														
Bank Charges	50	50														
Electricity	100	120														
Audit	100	120														
Salaries	2,200															
Depreciation	100	120														
Postage/Stationery	50	100														
Insurance	500	750														
General	500	540														
<b>TOTAL</b>	<b>6,000</b>	<b>7,000</b>														

If you therefore decide to increase your turnover, you have details of approximately what overheads you will require to carry out this function.

This also assists you when tendering for contracts as you know the minimum amount of overheads you must include in your nett cost and the required percentage can be applied as shown in Table 2.

Your percentage nett profit can now be applied to your final price as you have covered your operating and overhead costs and, depending on the nature of the contract, your own knowledge of the market will determine what element of profit you should include.

The required percentage to cover overheads can be adjusted if necessary if any

of the individual costs increase or decrease during the trading year but, the amount of any increase would be small and would not effect the overall running of the company's contracts.

Having this overhead control will make you more competitive in the tendering of projects and more in control of the money you are spending in order to make a profit and therefore survive in business.

At the end of your trading year your final figures would show as in Table 3.

Your therefore have achieved 20% gross profit on turnover; 10% nett profit on turnover; and 10% nett overheads on turnover.

As you can see, your overheads have taken away 50% of your profits and if you can find ways of reduc-

ing your overheads costs your profit will automatically increase. The breakdown of your overheads should be studied carefully to see if the cost of any item can be reduced, and priority should be given to the following items:-

**(A) Bank Interest:-** Considerable savings could be achieved by implementing and controlling your cash flow, detailed in depth in Part 1 of this series.

**(B) Insurances:-** Obtain rates for all insurances including employers, and public liability at regular intervals from various brokers;

**(C) Transport:-** Plan the delivery and requirements of material to sites and arrange in advance for delivery by the suppliers;

**(D) Depreciation:-** Control the use of plants on sites and have machinery regularly serviced.

Your control schedule (Figure 1) shows your actual costs for year 1972 and your estimated cost for year 1973 in which you are trading and, having based your previous cost as a percentage of your turnover, you now have a fair idea as to how much your total

overheads will cost for 1973.

By inserting the actual costs of each individual cost as they occur, you can monitor the cost of each item for comparison with your budget and, if one or more should be out of line, say after three or six months, you can take the necessary action, if possible, to control the problem.

Having completed your years trading for 1973, the amount of each month's costs can be totalled and used for comparison with your budget and as a guide to trading in 1974. Your differences, if any, can be studied to find out if any adjustments are required for future years and your control schedule therefore shows you all you need to know about your overheads.

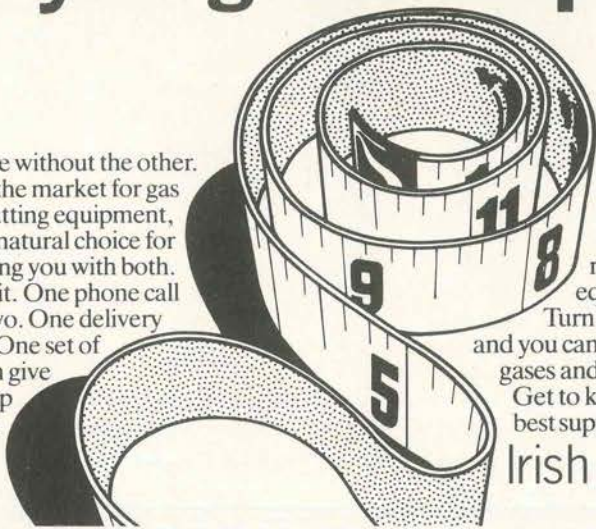
The growth of any one business depends on the company's objectives and policy, but the control of the finance of that company determines its rate of growth.

Value of Work Completed	say	£50,000
Costs Incurred	say	40,000
Gross Profit	say	10,000
Overheads	say	5,000
Nett Profit	say	5,000

Table 3

# You wouldn't order a three piece suit from different tailors. So why have different suppliers for your gas and equipment?

You can't use one without the other. So if you're in the market for gas welding and cutting equipment, we're the natural choice for supplying you with both. Think about it. One phone call instead of two. One delivery instead of two. One set of experts who can give you all the help and advice you need. It makes



sense, whether you're a D.I.Y. enthusiast or part of a huge metal fabrications business. Our service is tailored to fit your requirements and we even have the equivalent of an off-the-peg service. Turn up at one of our welding centres and you can take away the full range of gases and equipment. Get to know us. We're the two best suppliers in one.



## Irish Industrial Gases Ltd.

PART OF THE BOC INTERNATIONAL GROUP

CENTRES IN: DUBLIN, CORK, KILKENNY, LIMERICK, AND ATHLONE AGENTS AT: DUNDALK, ARKLOW, GALWAY, BALLYHAUNIS, CASTLEISLAND, AND WATERFORD

# veha

**Panel Radiators • Convector Radiators • 'V' Low-Line Radiators • Electric Radiators**

We have the experience and the know-how to give you the choice and the quality



HEAD OFFICE & WORKS  
VEHA LTD.: WICKLOW: IRELAND  
Telephone: Wicklow (0404) 2278  
Telex: 31171

DUBLIN — Longmile Road,  
Dublin 12.  
Tel. (01) 783466/500931/516519

CORK — Little Island,  
Cork.  
Tel. (021) 504268/506553

GALWAY — Earl's Island,  
Galway.  
Tel. (091) 61549

veha

**NEW PRODUCTS**

**Skyair from Coolair**

A new floor-mounted fan coil unit, the Sky Air, has recently been added to the Daikin range of air conditioners distributed here by Coolair Limited.

Used as a cooling unit only or as a heat pump, the Sky Air is also available as a ceiling mounted model, and in a choice of two attractive finishes — simulated teak and ivory.

Easily installed and quiet in operation it is designed to fit almost any decor and is ideal for use in executive offices, conference rooms, shops and restaurants.

A major feature of the new unit is its 'Auto Swing' mechanism. Concealed vanes in the air discharge grille slowly turn from left to right four to five times per minute distributing cool air evenly throughout the room.

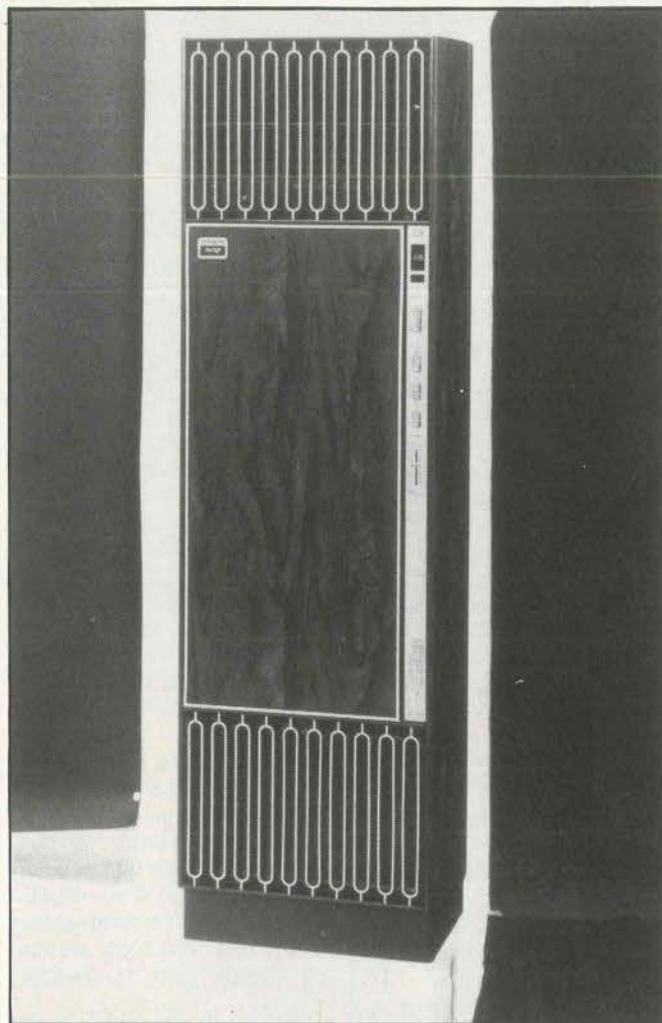
**Myson Unit Two**

The Myson Unit Two circulator is the result of three years development by a team of highly qualified engineers. It represents a new standard of technical excellence based on advanced thinking and the finest materials available.

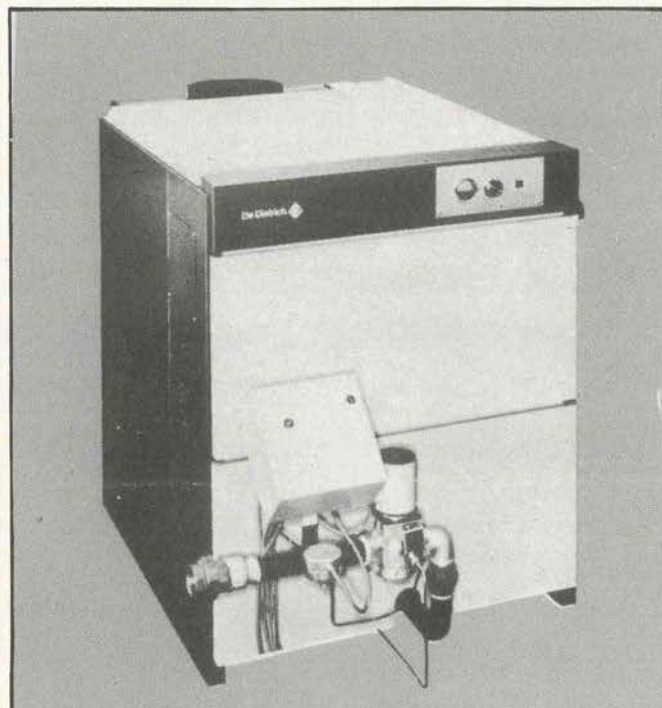
The design incorporates: A new 2-speed motor, new insulation standards, new bearing and air purging arrangements, new shaft and filter, a new motor housing, new easy to use flow regulator and the unique Myson screwdown clutch.

The Myson Unit Two is flexible. The one pump with its two-speed switch and its flow regulator can handle just about any domestic system for a new installation, or for the replacement of a pump in an old system.

The Myson Unit Two is economical. The two speed motor and the new easy to use regulator allow for performance to be accurately



● The Daikin Skyair unit from Coolair Ltd.



● Dietrigas boiler DTG-1000 with atmospheric burner especially designed for natural gas firing.

matched to duty, and the new bearings make smaller demands on electricity. Running costs are reduced to a minimum. The Unit Two is reliable. The whole unit is self-purging of air and the motor, which has a high-torque start, is insulated to Class H to ensure trouble free running mechanically and electricity.

The Myson Unit Two conforms to British Standards BS 1394. Enquiries are welcome at Myson (Ire) Ltd., Newcastle West, (Tel: (069) 62277 Dublin (01) 346989 Cork (021) 882113).

**De-Dietrich Cast Iron Sectional Boilers**

De Dietrich of Niederbronn, France have announced through their distributors in Ireland, Combex Engineering Limited, the availability of a range of cast iron sectional boilers with atmospheric burners suitable for Dublin Towns Gas.

The built in draught diverter allows for trouble free operation and the minimum flue height of 1 metre ideally suits rooftop installations. The DTG 1000 boilers are composed of single-element sections standing directly on the floor, requiring no refractory of special base. On the front side of the boiler, the combustion chamber is seated with refractory lined steel plate. The boiler body is fully insulated by means of glass wool. The control panel is pre-wired and includes regulating thermostat, limit thermostat with manual re-set; thermometer and on/off switch.

The burner is composed of stainless steel low noise, self stabilizing flame control ramps and manifold assembly, which are easily removed for maintenance. The burner is supplied complete with gas feed, ignition, flame control, main valve (governor) pilot

## NEW PRODUCTS

light valve; safety pressostat and permanent pilot. The unit is controlled by a fully automatic electronics box.

With the impending arrival of Natural Gas to Dublin the De Dietrich DTG range can be easily converted to Natural Gas. The range of sizes available commence at 156,000 Btu's/hr to 1.4m Btu's/hr.

The complete range of De Dietrich cast iron sectional boilers for oil and solid fuel are available from Combex Engineering Ltd., 3 East Road, East Wall, Dublin 3. Phone: 748371/2.

### Schwank Radiant Heaters

After an extensive development programme, Schwank Limited, the originators of the ceramic burner plate for gas-fired infra-red heaters, have developed a new range of radiant heaters — the Thermo-Schwank 2100 Series.

It is claimed that the new range of four models is 28% more fuel efficient than other ceramic or radiant-tube type heaters on the market, in achieving effective downward radiation. British Gas have fully approved the new heaters and the reduced input re-

quired to achieve the same radiant output as previous models has been confirmed by them in tests.

A special radiant regain panel has been introduced which increases the surface temperature and reduces the gas input required to achieve the 900°C temperature necessary for maximum radiant efficiency. The burner box has been re-designed to allow the flue gases from the radiant surfaces to pre-heat the gas and air mixture. This also provides increased efficiency and permits a further reduction in gas input.

Thus the Thermo-Schwank 2100 Series offers the same downward radiant output as its predecessor, but with a 28% saving in gas consumption, without any detrimental effect on the comfort levels in the building.

As a further aid to effective energy management, Schwank have incorporated an optional variation in the Thermo-Schwank series. The Pressure Drop Model is governed by a thermostatically-controlled valve. If the ambient temperature in the building reaches a certain predetermined level, the gas input will be reduced by 50%. Thus the full length of the heater will be used to supply half the previous level of radiant heat. This flexibility is not currently available with any other radiant heater of any type.

### Sodium Fluoride Saturator from IIL

The Advance II Series FS100 Sodium Fluoride Saturator, a system designed for adding fluoride to drinking water, is now available from Capital Controls Co., a Colmar PA-based manufacturer of chlorination equipment and related products. It is the most complete saturator system in the industry for use with small water supplies, especially those below 1 million gallons per day.

The unit is a pump and tank assembly with a swirl-action diffuser, that mixes water up through a dry sodium fluoride bed placed in the bottom of the tank. The resulting fluoride solution is then fed by a metering pump into the water supply.

The saturator comes completely assembled from the factory in floor or wall mounted versions. Both models are easy to install, requiring few on-site connections. Two different, medium-duty, chemical metering pumps are available with the saturator. The series 2100 pump has a

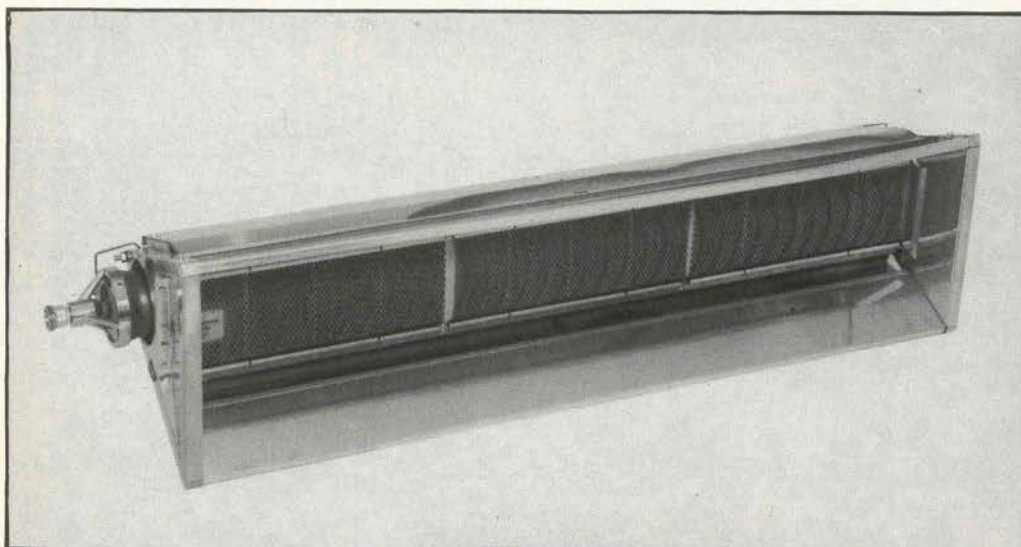
pressure range of 0-200 psi, and the series 2400 pump has a pressure range of 0-150 psi.

Many outstanding features are included as standard with this system. An inlet flow restrictor provides an optimum water flow of 4 GPM through the fluoride bed. Two separate anti-siphon valves prevent fluoride from siphoning back into the water supply and the uncontrolled flow of solution in case of negative pressure at the injection point. A special bypass valve and piping arrangement simplifies the priming procedures for both pump models.

For more information about the Sodium Fluoride Saturator, or any of Capital's other products, contact Industrial Instruments Limited, The Instrument People, of Herbert Place, Dublin 2, and also at Kilcoolishal in Cork (021) 822186.

### Differential Pressure Gauge

The new Capsu-Spirahelic (R) differential pressure gauge gives a fast, accurate indication of differential pressures up to 100 PSIG. Using the basic Dwyer time-proven Magnelic (R) magnetic linkage principle, the Capsu-Spirahelic movement is driven by a precision spirally-wound Bourdon tube. The pressure being measured is held within a capsule which is an integral part of the gauge. There is no piston to stick, diaphragm to leak, or "watch mechanism" to fail. The gauge withstands repeated overpressurisation up to its 500 PSIG maximum without damage. The spiral Bourdon tube design prevents mixing of media due to overpressurisation blowout devices or leakage across a piston. The gauge requires no liquid which might limit outdoor



● The Thermo-Schwank 2106.

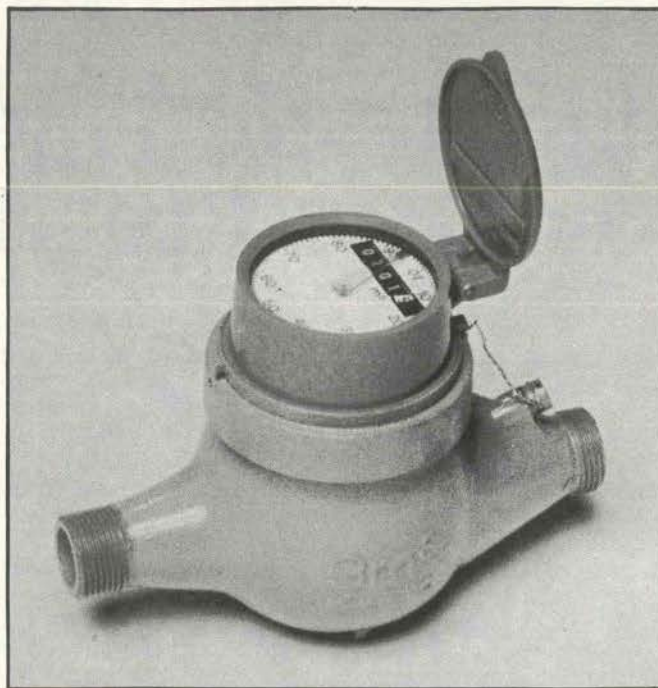
**NEW PRODUCTS**

applications, and there is no need to disassemble the gauge in normal service. The Capsu-Spirahelic housing is die cast aluminium with Teflon (R) impregnated hard coat anodizing. An optional forged brass housing is offered for water or water based fluids.

The gauge will measure valve drop, line loss, or filter drop in high pressure, high velocity air or gas systems and flow measurement using an orifice plate, venturi or pitot tube; also level measurement of liquids in tall tanks. Bulletin A-30S, Dwyer Instruments, Inc., PO Box 373, Michigan City, IN 46360. Telephone (219) 872-9141.

Teflon (R) is a trademark registered by DuPont.

Further details from: Manotherm Ltd.



● The Doris water meter from Combex Engineering.

10 Bars (150 psi). (Test pressure: 16 bars; 235 psi).

Consumption is read on number wheels and on a large dial with a central pointer that greatly facilitates readings, to the satisfaction of the consumer. A

stuffing box with an O Ring ensures leak proofing of the drive of this totalizer.

Graduations can be made as well in cubic meters as in imperial gallons, on request. It is protected by a cover (10) composed of an

**Flonic Schlumberger Water Meters**

Combex Engineering Ltd. are pleased to announce the availability of Flonic Schlumberger Water Meters. Schlumberger manufacture the Doris multi-jet turbine water meters for sizes ½; ¾; and 1" connections and the Woltmag Magnetic drive for 2" and 3" applications.

Doris meters comply with both the French standard and European Economic Community's regulations applicable to inferential water meters.

The Doris meter offers remarkable qualities as a result of its design (turbine balanced by multiple jet injection) and the quality of its manufacturing. Several million of units of this type are presently in service particularly in rural applications where they give every satisfaction.

The standard range of Doris meters is designed for: Cold water (maximum temperature 40°C, 014°F). Maximum service pressure:

envelope and a polycarbonate glass welded together ultrasonically.

The cover is waterproof and shock resistant. The cover is clipped into the brass screw ring and maintained by 16 clips that slot into the lower part of the ring. The glass is unaffected by ultraviolet rays. The lid (11) is positioned so that its hinge is perpendicular to the flow direction.

For further information contact sole distributors for Ireland Combex Engineering 3 East Road, East Wall, Dublin 2, Phone: 748371.

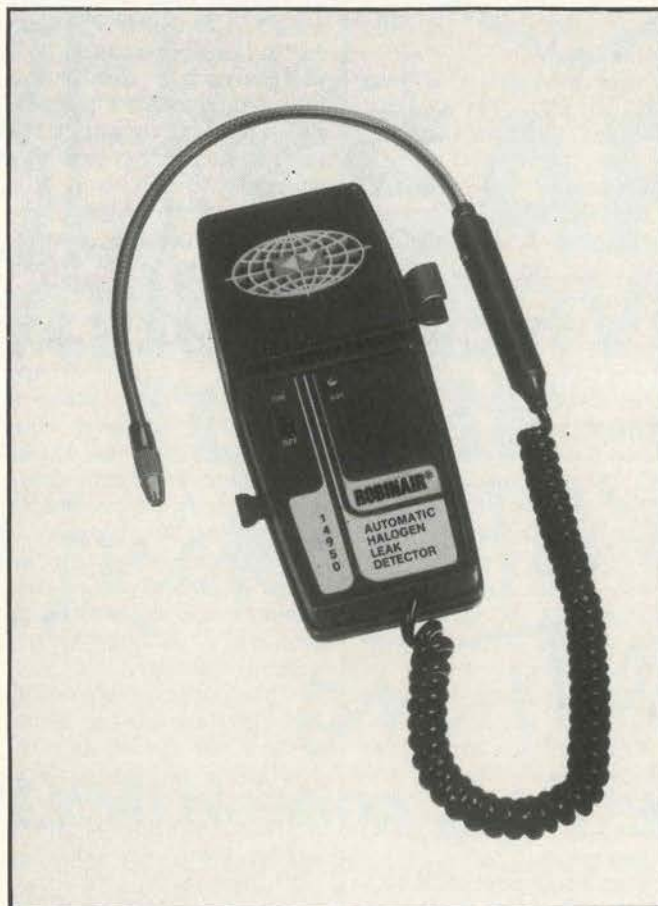
**Automatic Halogen Leak Detector**

Robinair announce the introduction of their entirely Automatic Refrigerant Leak Detector. Designated model 14950, the new instrument retains the advantage of its predecessor including an extra long probe leads and handle. An L.E.D. warning light indicates when the four "A.A." size batteries should be renewed; battery life is approximately 80 hours on alkaline cells.

Operation is entirely automatic, simply switch on, the Leak Detector adjusts itself to the ambient contamination level. Sensitivity is ½ oz. per year R12 in excess of ambient level; response rate and warm-up are instantaneous. A major advantage is the long life sensing tip which may be cleaned using common solvents.

The new instrument provides both audible and visual indications of a leak and pinpoints the leak without the practical disadvantage of excessive sensitivity. The instrument is supplied in a robust case and carries a 12 month warranty with full service facilities provided by the Birmingham factory.

For further details contact: RSL Ltd.



● The Robinair automatic Halogen leak detector.

# Mechanical Subcooling — The American Experience

Mechanical subcooling is the process of cooling the condensed liquid in a refrigeration system below its boiling point by use of an auxiliary refrigeration system. By subcooling this liquid, significant additional capacity can be gained for each pound of refrigeration circulated.

By using high temperature, high efficiency units to subcool lower temperature systems, electrical savings up to 25 percent can be achieved.

Subcooling is ideally suited to installations which require multiple levels of cooling. Supermarkets, for example, require relatively high temperature store cooling for the public, lower levels of cooling for the preservation of dairy products and produce, and frigid temperature for frozen food sections.

Mechanical subcooling, in fact, can be in any situation which employs a low temperature system, whether or not there is an existing high temperature system. Further, low temperature systems which are short of capacity can be expanded by the addition of a mechanical subcooling package.

Subcooling systems can be used in both existing and new systems. Retrofitting is a simple matter which requires only a minimum amount of piping, a subcooler and perhaps, an auxiliary compressor. The installation can be made in a minimum amount of time, and with minimum disruption of existing service.

Very few things which emerge in this industry are actually brand new, it would appear. And so it is with subcooling.

But re-emergence in this case, some believe, may

spark a fundamental change in commercial refrigeration — in light of today's energy costs and their effects on the profitability of grocery stores and supermarkets.

A system with deep mechanical subcooling can represent savings from 20% to 30% in kW usage for refrigeration compressors, first-cost savings through reduction in equipment sizing as the result of capacity gained, and reduction in maintenance costs by as much as 60%, according to some with application and service experience.

"Subcooling is nothing new", affirms John Motz, president of Kimmel-Motz Refrigeration Corp., a commercial/industrial refrigeration contractor in the United States.

"For example, it's been used in ammonia systems for years, and used frequently in industrial process applications".

By 1976 most people were desperately seeking energy cost relief, says Motz. In so doing, some first turned to various energy management systems — "black boxes", he calls them — and often experienced equipment damage, as well as grocery product deterioration as the result of misapplication.

To address the issue, Kimmel-Motz mustered all the company's engineering prowess with the objective of designing "a commercial refrigeration system with every practical means of conserving energy", says Motz.

Result of the effort was the company's "Whip" system (which stands for, "We Hope It Performs", he quips).

The basic approach is a series of smaller compressors in a "rack" (unitary as-

sembly), rather than fewer large compressors, to carry a store's refrigeration load (for example, 14 10-hp compressors instead of five 40's).

System control is handled by a special electronic sequencing panel.

And integral to the system is mechanical subcooling.

Fundamental operation of the subcooling system is to intercept liquid refrigerant coming from the condenser at something around 100° to 115°F, run it through a subcooler thereby dropping liquid temperature to approximately 45° using refrigerant from a higher temperature system as the evaporating agent, and then sending the deeply subcooled refrigerant to the store's cases.

"For each 2° drop in the liquid refrigerant's temperature, we pick up about 1% in capacity," explains Motz.

In the Whip system, subcooling of the low-temperature refrigeration system could be performed by either of the higher temperature (medium-temperature or air conditioning) systems. The air conditioning system, however, has the best EER of the three, and therefore, can more easily sacrifice a portion of its capacity, he explains.

There is a "greater refrigerant quality" in the case evaporators, explains Larry Rolison, Kimmel-Motz's general manager.

"Mechanical subcooling gets the flash gas out of the system, so the evaporator has more wetted surface. There is more capacity with a flooded coil — more useful work the coil can do", he says.

Also, notes Rolison, "There is constant liquid

temperature and pressure to the expansion valve, thereby eliminating frequent adjustment".

In comparable stores with comparable refrigeration loads, those with the multiple-compressor/multiplexed/mechanically - subcooled systems will have as much as 30% lower power consumption compared with conventional systems, according to Motz. "The lion's share — about 80% — of this difference is the result of low head pressure achieved through subcooling".

## Lower Maintenance

Lower maintenance is another direct benefit of mechanical subcooling, according to Rolison. Kimmel-Motz's print-out of service required per store per month shows a 60% difference between those with the subcooling feature and those without.

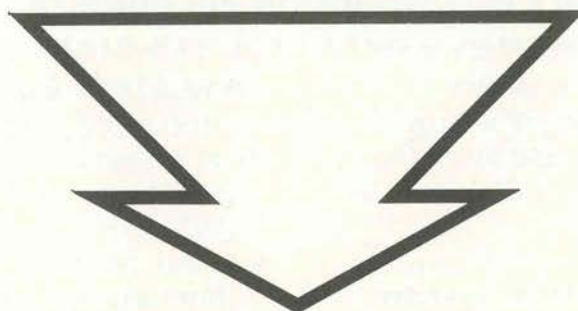
"They're running at higher average suction pressure", says Rolison. "The compression ratio is down, so they don't have the breakdowns."

Also, adds Motz, "Our sequencer drops compressors off the line when not required, so the suction pressure never changes." Because of the ability to unload this way, along with the ability to deep-subcool liquid refrigerant, he says, "the system runs at stable pressure and temperature regardless of ambient conditions".

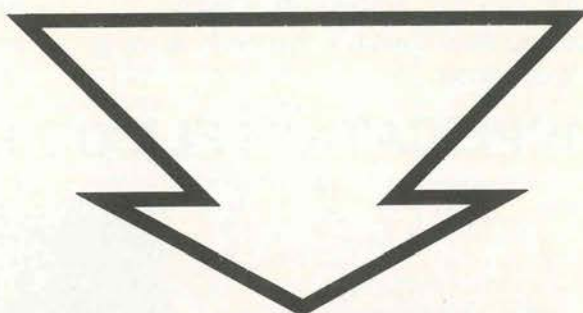
Use of multiple compressors in a heavily multiplexed system (a parallel system with multiple suction and liquid lines circuited through large headers) also is better for defrost purposes, he adds. All machines can assist in temperature pull-down upon defrost termin-



INTERNATIONAL BOILERS & RADIATORS  
INTERNATIONAL JANITOR  
HARFORD UNICAL  
WILLIAM SUGG



**THORN EMI Heating**



**21 YEARS**  
**HEATING SERVICE**  
**TO EIRE**

*Good Luck to H&V News  
on their 21st.*



**THORN EMI Heating The Housewarmers**

Eastern Avenue, Team Valley Trading Estate, Gateshead, Tyne & Wear, NE11 0PG.  
Telephone 0632 872211.

## PRODUCT REVIEW: REFRIGERATION INDUSTRIAL AND COMMERCIAL

ation.

There is a first-cost premium for Kimmel-Motz's system over a comparable conventional system, although "it's about the same cost as a standard system with an energy management system incorporated", says Motz. Paybacks with the subcooled system, however, is rapid enough to remove resistance to any extra cost, the company points out:

For example, says Motz, in the Los Angeles grocery store where 200 hp in compressor capacity was replaced with 140 hp and subcooling, actual data shows savings of from 25,000 to 30,000 kWh per month.

"At 1.5 cents per kWh, it means something, of course, but at 6.5 or 7.5 cents — today's energy cost — it could mean the difference between staying in business or not", says Motz.

#### Another Approach

At Hill Refrigeration Division's sales/manufacturing operation here, Don Taft, chief engineer, has been working closely with ambient subcooling for about five years, and with mechanical subcooling for six or seven months. A first system with mechanical subcooling was installed late last summer.

"It's easily applied to evaporative condensing systems", says Taft. The system is easy to balance in the Los Angeles area because of the consistent climate and corresponding stable refrigeration load, he notes.

A standard low-temperature refrigeration system is produced by this operation consists of a rack containing two compressors in a parallel circuit. Different from Motz's shell-and-tube-type subcoolers which serve the Whip system Hill uses smaller shell-and-coil-type subcoolers — one for each rack.

Subcooling can be provided, as in one particular application, by a medium-temperature (higher-suction-pressure/lower-compression-ratio) system serving the meat cutting room. This one medium-temperature

system provides subcooling for perhaps four of the two-compressor low temperature racks.

And, notes Taft when atmosphere can provide 115° liquid refrigerant, when mechanical subcooling can reduce temperature to 55°, and when for every 2° drop in liquid temperature you pick up approximately 1% in capacity. "This means 30% less refrigerant to circulate".

In areas where climate conditions are less consistent than Los Angeles, suggests Taft: "When head pressure is down to where the basic system can handle the load, the subcooler should be cut off. When head pressure rises, the subcooler can then be kicked in as a booster.

"It's a matter of balance", he says, adding that it can also be a matter of diminishing returns to leave the subcooling in effect as head pressure lowers.

Again he notes the importance of a consistent load:

"If the condensing temperature dropped to 90°, for example, the machine becomes oversized and the subcooler becomes oversized as well". This, he notes, would then dissipate much of the gain — principally because of system cycling.

While mechanical subcooling may also be applicable to air-type condensing systems, says Taft, "There can be problems if the load fluctuates, and there is change in the capacity of the machine with these systems". This changes the load for the subcooler as well, he adds.

Taft supports Motz's comments on today's increased interest: "It's more practical as cost per kW goes up. It's also significant in first cost".

Here he refers to a recurring application for a grocery-chain customer where compressor horse-power — including that for the mechanical subcooling — has been reduced from 122 hp to 97 hp.

Questions remain, however, says Taft — such as how much to subcool the

liquid refrigerant for balance and optimisation, and whether long buried refrigerant lines should be insulated.

He states one conclusion: "Although insulating the lines with atmospheric subcooling might not be worthwhile, it probably would be worth it with mechanical subcooling."

"For example you have a 55° liquid line; you don't want to lose temperature to the ground. If you spend the money to mechanically subcool, you want to preserve all you can."

Taft generally sees retrofitting of existing commercial refrigeration systems as "further down the road," concentrating instead on incorporating the mechanical subcooling feature into new system design.

However, in line with Motz's comments, he also mentions some installations light on capacity where problems were corrected by adding subcooling.

Taft cautions against adding the feature to a system working properly just to save on the power bill. "This could cause unloading problems," he says.

In general: "It's a viable thing and must be pursued," he summarises. He adds however, that he is "still mulling over the best means of controlling system balance with subcooling".

#### No Negatives

"There really are no negatives to deep mechanical subcooling — only benefits", says David Goldberg, manager of marketing and sales for Standard Refrigeration Co., which manufactures the subcoolers for both Kimmel-Motz and Hill.

Goldberg sees the approach becoming prevalent in commercial refrigeration systems within the next five years.

It may prove feasible to use a separate high-EER system, such as a high-efficiency residential comfort-type system, just to provide the mechanical subcooling, he adds.

The system is a west-coast phenomenon now, Goldberg notes: "It has evolved out here, principal-

ly because of operating conditions and uniform evaporative condensing temperatures."

But there is feasibility for northern applications as well, he believes — specifically in having mechanical subcooling offset (or "shave") additional refrigeration capacity purchased otherwise only to cover peak summer conditions.

*This article was supplied by S. P. Willison of Willison Controls Ltd.*

**The following notes are based on material submitted by the companies concerned.**

## Walker

Walker Air Conditioning Limited is the largest supplier of air conditioning equipment in Ireland, with an order book this year in excess of IR£5.5 million. As authorised distributor throughout Ireland, Scotland and the North of England, of Carlyle air conditioning and refrigeration equipment, their association with Carlyle stretches back over seventeen years. As part of Irish H & V News' 21st year of publication the following is a brief history of the company.

In 1970 the company became part of the giant Jefferson Smurfit Group and capital and new management were injected under the aggressive leadership of Jim Anderson who was appointed general manager. In 1972 Anderson was appointed Managing Director and has been the driving force in restructuring the company to give greater technical, administrative and sales depth.

In 1973 Walker set up its Glasgow operation and under the leadership of George Whillock, the new Managing Director, this is now the leading supplier of air conditioning and refrigeration plant in Scotland.

Walker, who also have a flourishing operation based in Belfast, have always attached great importance to providing efficient pre- and

## PRODUCT REVIEW: REFRIGERATION INDUSTRIAL AND COMMERCIAL

after sales service, and hold the largest stock of spares in Ireland. Their 5,500 sq. ft. Dublin warehouse also houses a spares sales counter and a large well equipped workshop for compressor and other off-site repair work.

The company also has its own team of refrigeration installation and commissioning engineers.

The company's main activity is the distribution of Carlyle products in Ireland and Scotland, but it has developed additional distribution interests, mainly for products compatible to Carlyle. These other ranges include Walk-Air dehumidifiers, Condair humidifiers, Vokes filters and Honeywell electrostatic filters, WAC Chesterton industrial sealing and maintenance products and Girdlestone pumps.

In late 1979 HRP Walker, a wholesale distributor of refrigeration components, was launched to supply a local based refrigeration spares service to the trade. A range of some 30 or so lines is offered from stock, including copper tubes, Isceon refrigerant, Aspera, DWM Copeland Danfoss and Lec compressors and condensing units, KMP driers, Imperial Gould and Robinaire servicing tools; Watsco line valves, Ranco and Penn controls, Armalex insulation and Sabroe components.

Despite their diversification into allied fields the supply of Carlyle equipment remains the pivot of the Walker operation. The secret of their success lies in their commitment to service both before and after sales, and contractors, consultants and users have all benefitted.

Another of the Walker strengths is that they are forward looking, and at this moment the company is appointing residential heating dealers in the 32 counties in readiness for the arrival of the residential heat pump market which they expect to start to break next year.

Through their Carlyle distribution franchise, are

able to offer a wide choice of heat pumps for residential applications, air to water, water to water, air to air and water to air. These heat pumps with cop's of around 3.0, can be used in new or refurbishment installations as the sole heat source or alongside conventional oil fired boilers. The Company has supplied substantial numbers of larger model heat pumps for commercial and industrial premises in the last two or three years.

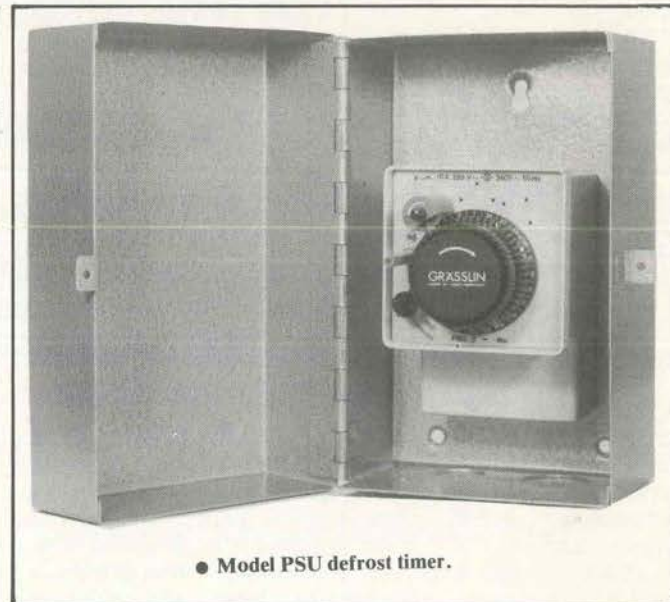
By appointing Dealers now the company can ensure that personnel in these dealer organisations are properly trained in the application, installation and servicing of heat pumps.

The company has done a great deal over the years to raise standards in the ac industry in Ireland through regular training programmes. These are managed and run for Walker by A & I.R. Training Limited, an AnCO approved company, which means that organisations sending people can receive a grant of up to 50 per cent of the course costs. Demand for the first course of 1982 was so great that another is planned for later in the year and interested parties should contact J. Anderson at Walker Air Conditioning Limited, Dublin, Telephone: Dublin 300844.

## Grasslin

Grasslin Ltd. announce additions to their range of quality defrost timers including the provision of a lockable sheet steel enclosure where required.

Among the wide applications of synchronous programming the PSU is especially suitable for defrosting in a commercial refrigerator or island unit in supermarkets etc. Normally defrosts are programmed on a 4-6 times per day basis depending on the requirement. They are on timed sequence with an override feature where necessary to terminate the defrost once the cabinet temperature indicates that frost has been removed from the coils.



● Model PSU defrost timer.

The major feature of the PSU series consists of a master clock with a 24 hour dial. The defrost period can be triggered anywhere on the dial by means of tappets which can be set to a two hour minimum between defrost starts. The tappets initiate a variable defrost period, the adjustment capabilities being between two and 55 minutes. In addition to the standard model there is also a model with solenoid termination so that the defrost period may be terminated by means of an external thermostat or pressure sensor. A further configuration is available with a model that features both the solenoid termination and an auxiliary relay for fan delay applications. All of the 24 hour clock models are available in a rugged sheet steel enclosure affording conduit entry and locking facilities.

A seven day master clock is available if required.

The company supply a special purpose timer, model HTUM which offers fixed time settings of 36, 45 or 60 minutes by means of plug-in tappets.

Notable features of the timer are the ease of setting up and the ability to set different defrost periods throughout the 24 hour cycle. The model has integral solenoid for defrost termination from an external thermostat or pressure switch. Spring reserve is available if required.

A sheet steel enclosure af-

fording conduit entry and locking facilities is also available.

## Custom Coils

A leaflet supplementing Custom Coils' product range illustrates with brief technical details their American-licensed products for which individual bulletins (giving specifications, capacities and dimensions of the various models) are also available. These are the products described:-

Evaporative condensers (bulletin EC 110). HCU and AFC models. Capacity 184 kW (629 Btu/h) to 4428 kW (15,164,000 Btu/h). Nominal ammonia. Suitable for refrigeration and air conditioning.

Closed circuit coolers (bulletin ECC 112). CCC and LCC models. Capacity 2.3 litre/s (30 gpm) to 158 litre/s (2085 gpm). Suitable for process liquid cooling, engine jacket cooling, industrial fluid cooling, etc.

Cooling towers (bulletin ECC 112). CTO models. Capacity 6 litre/s (80 gpm) to 151 litre/s (2000 gpm). Suitable for refrigeration and air conditioning, industrial water cooling, plastic mould cooling, die cooling, etc.

Ammonia product coolers (bulletin GSP 121). AHA/AHB medium temperature models. Capacity 30 kW (102,390 Btu/h) to 209 kW (713,000 Btu/h) nomi-

# HRP Walker.

A familiar name  
for many  
familiar brands.

**Isceon Refrigerant, DWM Copeland Condensing Units and Compressors, Searle Coolers and Condensers, Teddington Thermostats, Imperial Gould Servicing Tools, Robinair Tools and Service Equipment, Watsco Line Valves, Lec Condensing Units and Compressors, Ranco Controls, Danfoss Compressor and Condensing Units, Armaflex Pipe Insulation, Crane-Enfield Copper Tubing, Insultube Ape Insulation and Sleeting, Sabroe Components.**

## **NEW FOR 1982**

1. Comef open type condensing units and compressors.
2. Coplaweld hermetic compressors.
3. Penn controls (press switches, thermostats, etc.).
4. Grasslin defrost controls.
5. Searle C.D. unit coolers (replace UCL range).
6. Teddington large capacity T.X. valves, for R.12, 22, & 502.

**THE BEST PRODUCTS! THE BEST SERVICE! 2 LOCATIONS! 32 COUNTY COVERAGE!**

# HRP

# HRP WALKER

Unit 100, Slaney Road, Dublin Industrial Estate, Glasnevin, Dublin 11. Tel: 729988 Telex: 25831  
9A Cherryhill Road, Dundonald, Belfast BT 16 OJH. Tel: Dundonald 5234 Telex: 747681



a member of the Jefferson Smurfit Group.



# fridge spares

(WHOLESALE) LIMITED



**L'UNITE HERMETIQUE**  
COMPRESSORS &  
CONDENSING  
UNITS



**Delta Ltd.**  
Evaporators &  
Condensers



DRIERS  
EXPANSION  
VALVES

**ISCEON**  
Refrigerant  
Gas



**COPPER  
FITTINGS**

*Glacial*

**EVAPORATORS**



RANCO

**CONTROLS**

*"Annie"* Instruments

IMPERIAL  
EASTMAN  
Hand Tools

**Armaflex<sup>®</sup>**



rabtherm

**VACUUM  
EQUIPMENT**

Available from the Irish agents:

37D Dublin Industrial Estate, Glasnevin, Dublin 11. Tel: 303466 & 303793 Telex: 30987.



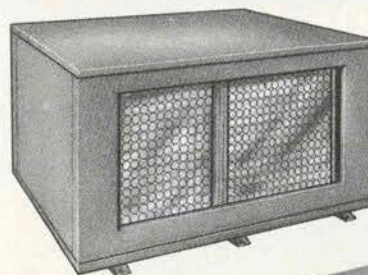
**Hall-Thermotank  
Ireland Limited**

Refrigeration and  
Air Conditioning

## DELTA CLIMA Packaged Air Conditioning Equipment



Type C.C.U. curved  
coil condensing  
units



Horizontal air handling units.  
Chilled water and DX.



Type RA roof  
mounted air  
cooled units

Vertical air handling units.  
Chilled water and DX.  
Air cooled and water cooled.



Downflow air  
conditioning units.  
Chilled water  
and DX.

Exclusive Distributor in Eire

**Hall-Thermotank Ireland Limited**

Hall House, Main Street, Rathcoole, Co. Dublin. Tel: (01) 580311 Telex: 30943

**PRODUCT REVIEW: REFRIGERATION INDUSTRIAL AND COMMERCIAL**

nal 16 deg C TD recirculated ammonia. AFA/AFB low temperature models 29 kW (99,000 Btu/h) to 283 kW (966,000 Btu/h) nominal 16 deg C TD recirculated ammonia. Suitable for flooded, liquid recirculation or direct expansion systems.

Ammonia unit coolers (bulletin GSP 123). HTS medium temperature units. Capacity 13.8 kW (471,000 Btu/h) nominal 16 deg C TD direct expansion ammonia. LTS low temperature units 14.5 kW (495,000 Btu/h) to 99 kW (338,000 Btu/h) nominal 16 deg C TD direct expansion ammonia. Suitable for flooded, recirculated or direct expansion systems.

Ammonia unit coolers with stainless steel casings (bulletin GSP 124). ATR units. Capacity 19.5 kW (66,500 Btu/h) to 72 kW (246,000 Btu/h) nominal 16 deg C TD recirculated ammonia.

Galvanised steel coils (bulletin GSP 128). Constructed from 3/4-in OD x 0.049 (1.25 mm) wall or 1-in OD x 0.060 (1.5 mm) wall, welded steel tubing. Tested to 400 psi (27 bar) air under water.

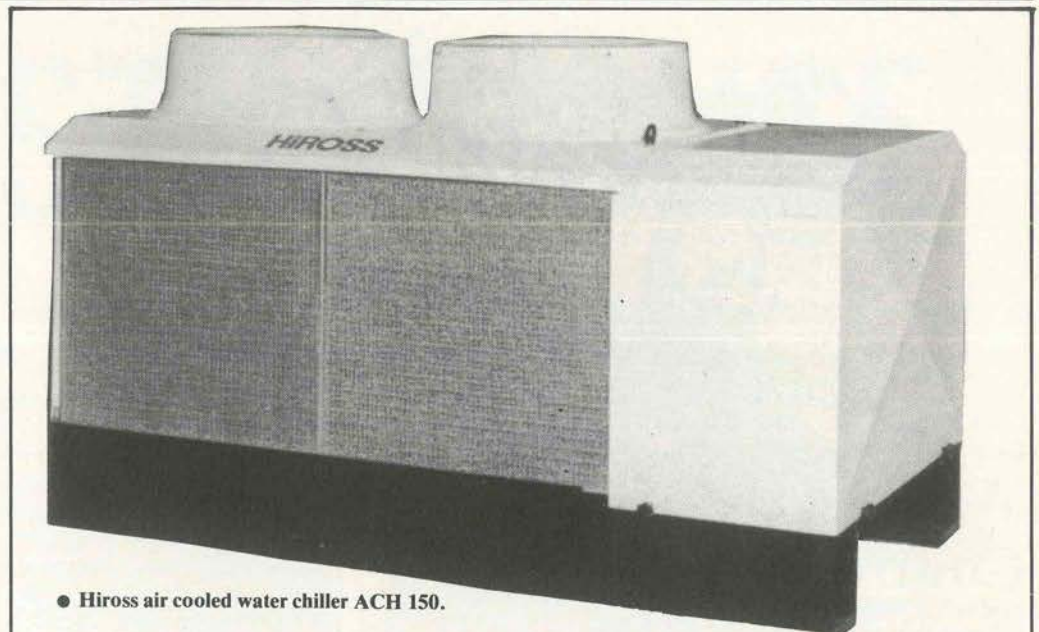
Another new bulletin (ACC 68) gives details of Custom Coils-designed ammonia air cooled condensers. ACR standard range. Capacity 8.5 kW (30,000 Btu/h) to 685 kW (2,166,000 Btu/h). 'Q' range low noise level: 7.3 kW (26,000 Btu/h) to 601 kW (1,900,000 Btu/h). 'R' residential range ultra low noise level, low power consumption. 8 kW (29,000 Btu/h) to 281 kW (887,000 Btu/h). These models are engineered and designed specifically for the ammonia market.

Custom Coils, a member of the Capper Neill Group, is at Woodside Avenue, Eastleigh, Hampshire SO5 4JQ. Telephone: Eastleigh (0703) 614694. Telex: 47237.

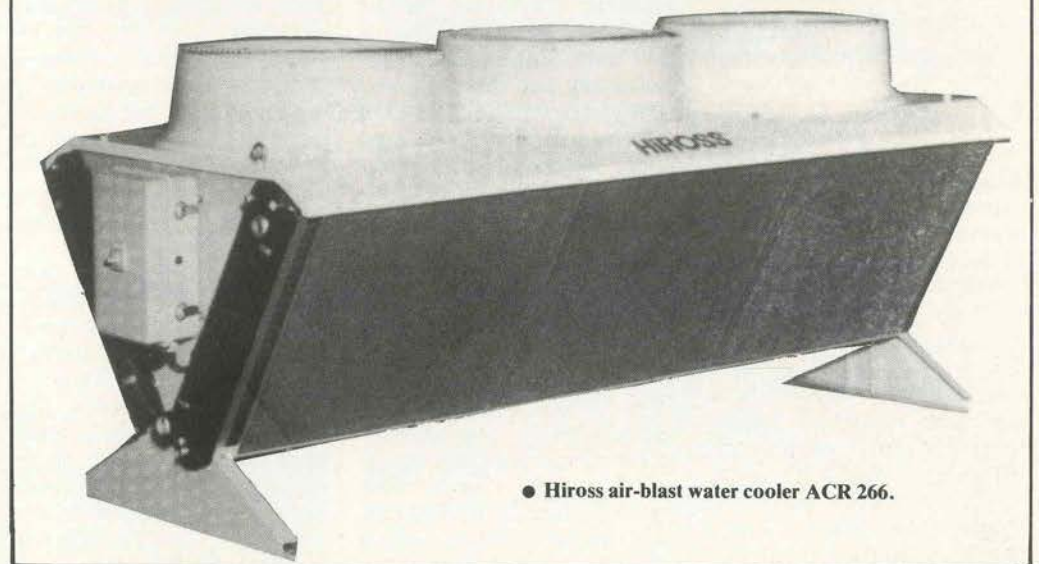
## Hiross

### Air Cooled Water Chillers ACH Series

This range of water chillers has been especially develop-



● Hiross air cooled water chiller ACH 150.



● Hiross air-blast water cooler ACR 266.

ed for minimum energy consumption by increasing the relative E.E.R. (Energy Efficiency Ratio).

As optional, they can also be fitted with the How-omatic, a Hiross exclusive, to produce hot water up to 65°C at no extra cost.

The range covers eight models, with capacities from 10.5 kW (35,800 Btu/h) to 84 kW (286,700 Btu/h) with either one or two compressors and independent refrigeration circuits.

The units are solidly constructed and fully weather protected for outdoor installation.

The plastic covers, with which every chiller is fitted, are made using the same techniques as employed in nautical engineering, to obtain the maximum protection from atmospheric

corrosion.

### Air-blast Water Coolers ACR Series

These coolers substitute cooling towers in providing cooling water in closed circuit. This gives the great advantage of reducing water consumption to nil, perfect functioning even when the outdoor temperature is below zero and completely eliminating the maintenance requirements of the heat exchangers in the cooled circuits.

The units are completely weather protected for outdoor installation and fitted with axial fans with vertical airflow for quiet operation.

The coolers are suitable for use in energy recuperation schemes and are available with capacities from 14 kW (47,800 Btu/h) to 330 kW (1,126,300 Btu/h).

## Trane

The RAUA condensing units are fully weather protected for outside use and perform the function of air cooled condensing. The complete Split-System can be formed by matching these condensing units with the relevant BACA fan coil units.

The units comprise: compressors Cu/Al "Sigmaflo" condenser coils, copper pipe connections with a holding charge, direct drive fans, all necessary controls and protection, hoisting lugs and mounting rails. Units are also available with copper fin condensing coils. (400 V, 3 phase, 50 cycles).

Accessories: Coil guard, low ambient kits, anticyclone timers.

PRODUCT REVIEW: REFRIGERATION INDUSTRIAL AND COMMERCIAL



● Standard air dryer sets from Willison Controls Ltd.

## Willison Controls

Stand Refrigeration manufactures a complete line of air-to-air and air-to-Freon heat exchangers, with capacities from 400 to 12,000 SCFM.

Standard's years of heat transfer experience has produced a unit with maximum capacities and minimum pressure drops in compact units. Close tolerances, heavy wall tubes and Standard's unique spiral fin insert all contribute to the finest heat exchanger sets for air drying applications. All units are made to ASME specifications, and are shipped complete with heads on both heat exchangers and full 3/4" high-density insulation on air-to-Freon units.

In air-to-Freon units, Standards, patented Spiral-fin® tube design uses centrifugal force to provide maximum surface contact and minimal slugging.

\* Factory aligned before welding to ensure fast, accurate installation.

\* Heavy gauge tubes for longer life and greater efficiency.

\* Baffle tolerances twice as tight as competitive units, for minimum slippage.

\* Shipped complete with heads and insulation. No hidden costs.

\* Efficient design for maximum heat transfer and minimum pressure drop.

For full details and prices contact Willison Controls Limited, Dallas Road, Bedford MK42 9ES, (Tel: (0234) 52286/7/8 Telex: 826827).

## Satchwell

Satchwell Control Systems Limited is a major manufacturer of controls for heating, ventilation and air conditioning installations. For various reasons it was necessary for the company to withdraw from Ireland in 1977 but in 1980, following some internal reorganisations and the success of its Northern Ireland office, the company opened a new, and permanent, office in Store Street, Dublin.

It is thought that Satchwell is the only international company in its field to have a complete regional office in Ireland, manned by company-trained engineers. Clients now have the benefit of immediate access direct to a manufacturer; staff in Dublin can call on Satchwell's head office for any help they may need, and receive the same comprehensive support from head office by way of exhibition participation, specialist advice and any other requirements, as do the company's other regional offices.

But Satchwell Control Systems is not just a manufacturer. While manufacturing and supplying controls ranging from simple optimisers, through central plant and zone controls to complete computer-based building management systems, it also provides all the other services which may be required. These include the design, manufacture and installation of control panels, and indeed of complete systems, both electronic and pneumatic. Followed by commissioning, and subsequently contract maintenance if required, this means that Satchwell has the experience and facilities to tackle all aspects of the work needed in connection with a building's environmental services, both in new buildings and when refurbishing older ones.

Further information from: John Coffey, Satchwell Control Systems Limited, 20 Store Street, Dublin, Ireland, (Tel: (01) 724926).

## McQuay

The latest series of McQuay reciprocating water chillers embrace new and important technology. For both A.C. and refrigeration applications, the ESH water cooled range features variable speed operation to achieve major fuel and other running cost savings.

Over the years McQuay has been responsible for many important innovations, and is the only company able to offer chillers equipped with semi-hermetic multiple speed compressors.

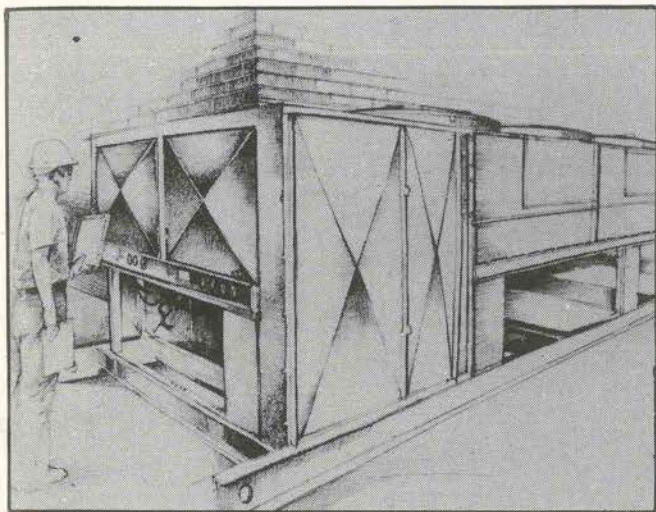
In any air conditioning system the chiller only operates for short periods at full load, for most of the time it is working well below its maximum capacity at a point where the efficiency is low, and the energy consumption per KW of cooling output rises sharply. With the new series of units, using compressors exclusive to McQuay, output can be continually modified to match variations in demand, whilst at the same time COP actually increases. It will readily be appreciated, say Commac, that this provides a substantial energy saving when compared to more conventional refrigeration systems employed in other units.

In addition to offering more rational energy management, these variable speed chillers provide higher reliability and durability. The life of the average traditional reciprocating water chiller is understood to be a maximum of 17 years, whilst the ESH can be expected to provide effective service for well over 25.

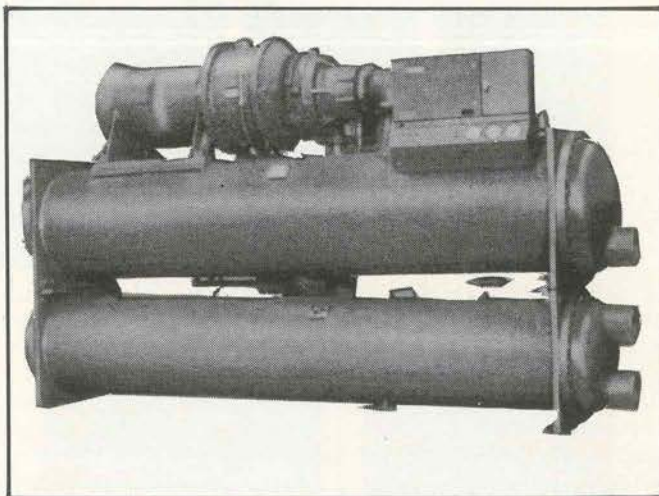


● The Zonemaster range from Satchwell Ltd.

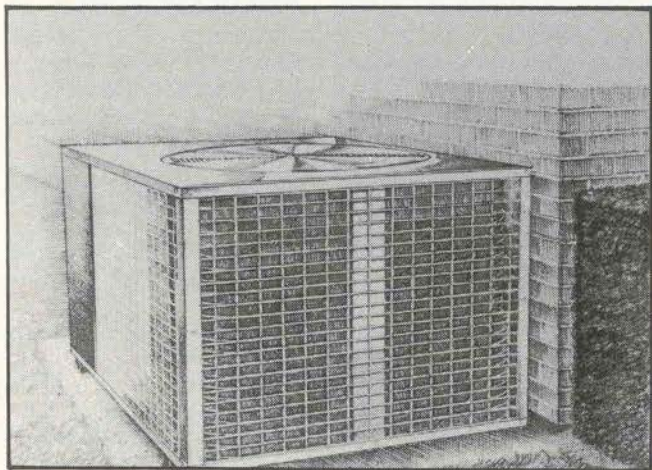
# WESTINGHOUSE



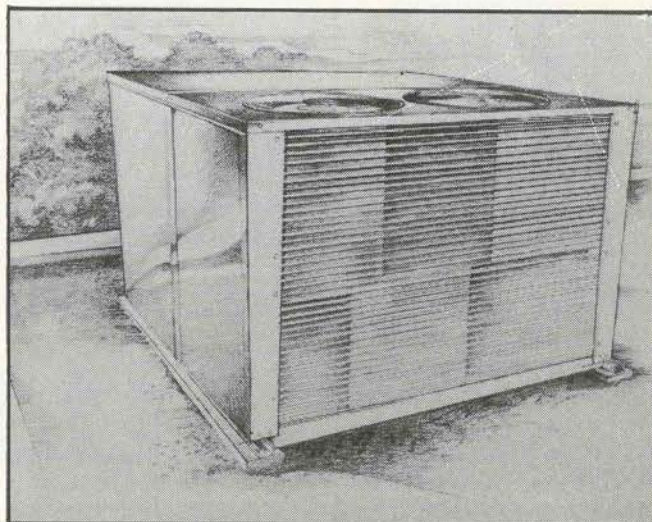
● Westinghouse P.D. Packaged Water Chiller Air Cooled.



● Westinghouse P.E. Packaged Water Chiller Water Cooled.



● HP Split Heat Pump



● IK Rooftop Unit

## INDUSTRIAL AND COMMERCIAL APPLICATION DESIGN FACILITIES

For Further Details Contact Sole Irish Distributors:

**Reconair**

Unit 4A Coolock Industrial Estate, Dublin 5.  
Telephone: (01) 470611/470209/470113. Telex 31356.  
Also available on Pageboy Tel: (01) 972229 - Unit 804-347-345  
Castlemahon (069) 62818 Galway 093-24896



# LOOKING BACK AT 21 YEARS OF CONTROLS

**Mr. B. Sampson of J. J. Sampson & Son Ltd. takes a look back at 21 years of controls in the refrigeration and heating industries.**

In looking back over the last 21 years in the context of Control Equipment for the heating, oil firing, industrial and refrigeration areas it is first necessary to look at the type of market that existed in Ireland as we moved into the sixties. The situation was very different from the present. Economically, we were attempting to expand our industry, the farming community were struggling and there was no great affluence in the urban areas. As a result, for example, central heating was still a luxury rather than the accepted norm, as now, even though oil was only about five pence or less (old money) per gallon!! The food processing industry was getting off the ground with the attendant expansion in the requirement for refrigeration facilities. In the manufacturing area the production methods used were in general, fairly unsophisticated with a greater labour content than could be afforded today. The days of spiralling labour costs and inflation had not yet arrived. In this market climate the demand for control equipment was fairly modest. The next two decades changed all that.

In the context of the evolution of control equipment over this period it is easier to look at one area for the sake of simplicity. If

we take oil burner controls alone 20 years has brought many changes in design and method of operation. At the turn of the 50's the safety control method in the majority of instances, was still the thermal Bi-metal which performed the required function but was comparatively slow to react and very dependent on its location on the boiler. Silenium cell systems were also in use and while they gave fast reaction they tended to give trouble because the current they generated was tiny and had to be amplified to operate relays. In addition the cells themselves degenerated with time. With the advent of photo resistors at the time a big step forward took place. They were much more reliable, gave fast reaction and good life time but the control boxes themselves were bulky because of the internal wiring and comparatively large relays and components. With the arrival of transistors and printed circuit boards we were on the way to the miniaturisation we are all familiar with during the 70's. Today with the use of solid state technology and sophisticated production methods we are marketing products with a high reliability coupled with long life. The end result, strangely enough is, that taking inflation into account, burner controls today are cheaper than they were 21 years ago!

In the industrial sphere, electronics have entered the

arena in a big way particularly in the last decade. We now have electronic controllers for speed, temperature, time. Monitoring equipment for flow, volume, pressure, temperature, etc. Today all this equipment is to be found built in to production machines and plants thereby achieving better output, quicker reaction to production faults, with resultant higher efficiency. It is pleasing to record the Irish industry in recent years has seen the need to modernise and update production methods to retain and improve competitiveness in the market place. Production engineers around the country are now receptive to new innovations and methods where in the past they tended to be conservative in outlook.

In short it can be said that in the last 21 years we have evolved into the age of electronics. It would be interesting to bring back some of the old "characters" who abounded in the maintenance and service industries in the last 50's and hear their comments on the "black boxes" that now substitute for their "a turn here", "half a turn there" adjustments. In a way their passing has taken some of the fun out of life.

One must remember that twenty plus years ago there were only a handful of companies of any size operating in the heating and refrigeration services area in Dublin. So everybody knew

everybody. Some have regrettably long gone, Maguire & Gatehell and Bairds for example. Many still very involved in the heating business to-day started in Maguire & Gatehell. One can only look back with a degree of nostalgia and at the same time laugh at the many "Funny Incidents". The sight of a well known but portly architect, to avoid a confrontation with a difficult client, climbing out through a tiny rear window to join a site meeting in the boiler house still lingers — the business tycoon who convened a meeting of consultant, architect and control supplier to complain that the Thermostatic Radiator Valves fitted would not hold bedroom temperatures at the desired level with the windows wide open! The storeman who painted over the windows of photo resistors with black paint because he was instructed to keep them "in a dark place" (as with Silenium Cells). The advent during the boom times of the "cowboy" installers who conned their unfortunate customers right, left and centre, and the stories of the chaos they left behind. Lastly the "hard" men in refrigeration who did their ordering and solved their problems after office hours in the local pubs. Today things are different right across the board but I personally would not like to have missed the "old days" for any money.

## SMC to Distribute York Range

SMC Air Conditioning have recently been appointed sole distributors for the full range of York air conditioning and refrigeration equipment. One of the most exciting developments in recent years in the York Energypak. Many features of the unit are totally exclusive to York. SMC can now offer full technical sales and back-up service facilities for the complete range of York equipment.

Over the past three years, SMC has built up a maintenance and service department which operates on very high standards and the success of this operation can be gauged from the list of clients they now cater for including Irish Life, Bord na Mona, Ulster Banks, AIB, Abbot Labs., Fry Cadbury to mention but a few.

The major complaint from users of most types of air conditioning and fridge equipment in Ireland over the last few years has been the lack of after-sales service and technical back-up facilities. S.M.C. have now established themselves as the market leaders in providing this after sales service for various products and their link up with York who have over the years shown that their equipment is second to none on the market should prove to be a very formidable combination if resources and services to ensure your equipment gains its share of the Irish market.

● Latest Westinghouse dual compressor, air-cooled water chiller.

## Fridge Spares

Fridge Spares Wholesale Limited one of the leading refrigeration wholesalers in Ireland dealing solely with the refrigeration trade.

Extensive stocks of equipment and ancillaries are kept at the Dublin Industrial Estate warehouse such as Delta RA evaporators and condensers, Lunite Hermetique condensing units and their latest addition to the range, Hall Bitzer semi-hermetic condensing units.

On the ancillary side large stocks of Flica driers and expansion valves, Ranco controls, Gill brass fittings, Nibco copper fittings, Yorkshire copper tubes, Danfoss solenoids, Precision time clocks, Armstrong Armaflex, Isceon refrigerants and many other items can be had ex stock.

A very good range of imperial Eastman tools and test equipment can also be delivered from stock.

For further information contact: Fridge Spares

(Wholesale) Limited, 37D Dublin Industrial Estate, Glasnevin, Dublin 11, (Tel: 303466/303793).

## HRP Walker

"The frig trade seems delighted with our new bigger premises", reports Tony Madden, field sales manager HRP Walker, the refrigeration components wholesale subsidiary of Walker Air Conditioning. "They like the location on the Dublin Industrial Estate, they like the easy access with good parking, and they are delighted with the increased product offering", he concluded.

The new lines on offer are Penn controls, Comef condensing units and Coplaweld hermetically sealed compressors, all of which have been well received. Demand has been strong for the Searle products which the company has been offering now for some months, particularly the T range of compact coolers for cabinets and small cold rooms, the UCL and K ranges of standard unit coolers for medium or low temperature applications and the new low velocity coolers for food

preparation areas.

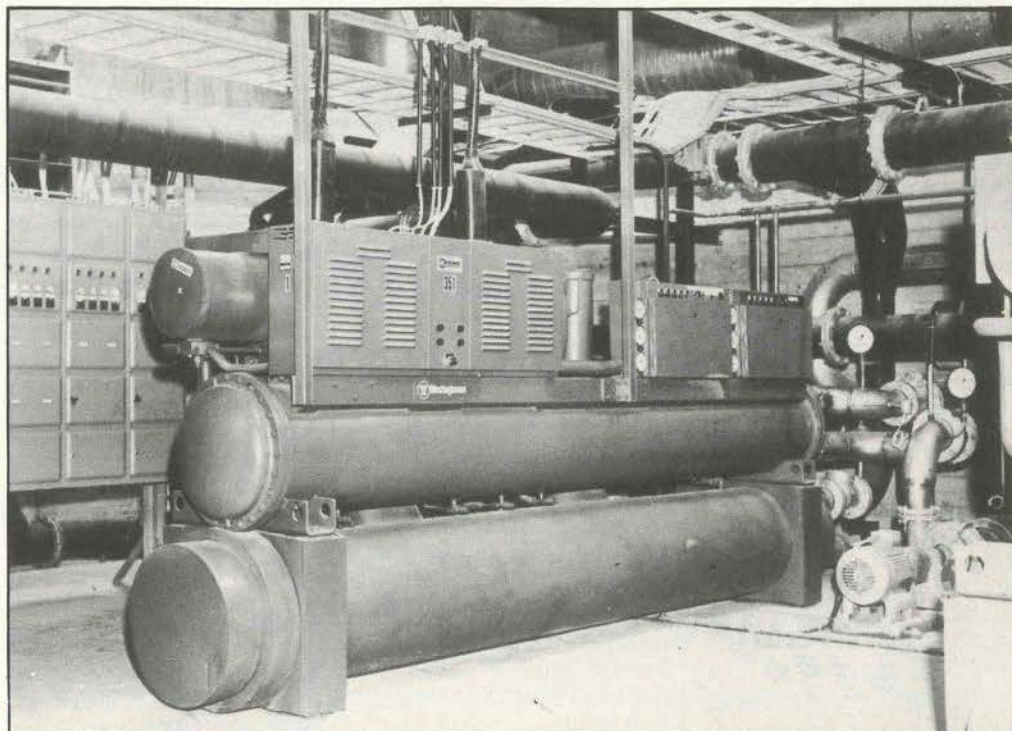
HRP Walker also offers the Carlyle 5H compressors which are renowned for reliability; Isceon refrigerant; copper tubes; Aspera, DWM Copeland, Danfoss and Lec Compressors and condensing units; Teddington Thermostats, pressure controls and expansion valves; KMP driers; Imperial Gould servicing tools; Watsco line valves; Ranco controls; Armaflex Insulation and Sabroe components.

All these products are available from HRP Walker's new 6,000 sq. ft. premises in Slaney Road, Dublin Industrial Estate, Dublin 11, also through their Belfast premises, 9a Cherryhill Road, Dundonald, Belfast.

## Westinghouse

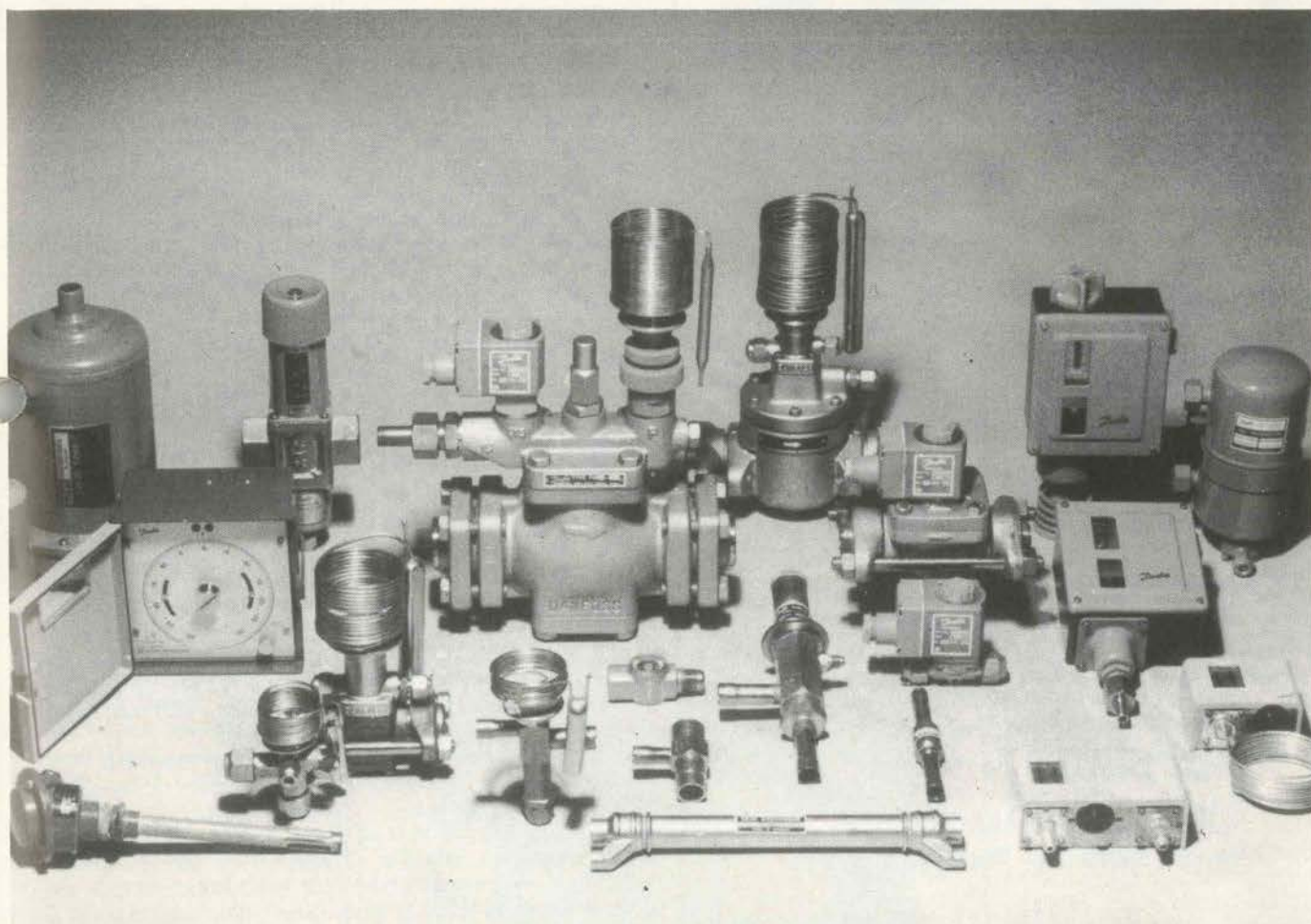
Westinghouse, the only manufacturer ever to offer a dual centrifugal compressor chiller has just enlarged the range from 250 to 450 TR. Uniquely this series embraces all the advantages of single and multiple unit installation in an integral package.

The Westinghouse dual



# DANFOSS

## FULL RANGE OF REFRIGERATION CONTROLS



- \* THERMOSTATIC EXPANSION VALVES
- \* CONSTANT PRESSURE VALVES
- \* THERMOSTATS & PRESSURE SWITCHES
- \* CHECK VALVES
- \* OIL SEPARATORS
- \* LIQUID LEVEL CONTROLS
- \* HEAT EXCHANGERS
- \* WATER VALVES
- \* COMPRESSORS (1/12 to 3/4 H.P.)
- \* SOLENOID VALVES
- \* PILOT OPERATED SOLENOID VALVES
- \* PRESSURE REGULATORS
- \* SIGHT GLASSES
- \* FILTER DRIERS
- \* PILOT OPERATED MAIN VALVES
- \* ELECTRONIC CAPACITY REGULATORS
- \* TROTTLER VALVES
- \* CONDENSING UNITS (1/6 to 3/4 H.P.)

*Danfoss*

Irish Agents for Over 30 Years

## J. J. SAMPSON & SON LTD.

Unit 71, Cherry Orchard Industrial Estate, Dublin 10. Tel: (01) 268111 Telex: 92219

**PRODUCT REVIEW: REFRIGERATION  
INDUSTRIAL AND COMMERCIAL**



**JOHNSON  
CONTROLS**  
Penn  
Products

**A name that fits the energy  
conservation programme**

A name that represents a large variety of controls, such as:

**Thermostats, Humidistats,  
Pressure Switches, Watervalves, etc**

These controls are suited for HVAC, refrigeration, heatpump and naturally for energy conservation applications.

If you consider economy, durability and quality to be important features of your control requirements, then Johnson Controls is ready to meet your demands.

**A name in controls**

Represented in Ireland by:

**MANOTHERM LTD**

Dublin, phone (01) 522355/522018/  
522229, telex 24467.

Belfast, phone (084) 645966.

centrifugal compressor chiller was first introduced in 1970. In addition to the recent range extension, a number of important cost saving benefits have been incorporated. The air cooled series offer all the advantages of a single package, as well as the benefits and flexibility of multiple units. It costs less than two separate chillers to buy, installation takes nearly half the time, and fuel operating expenses are lower than with either one large or two small units.

This range of chillers incorporate Westinghouse's own compressors. For optimum efficiency these are computer matched with enlarged heat transfer surface evaporators and condensers; by incorporating an isolation system for motor cooling this capacity is available to each compressor, which can develop 60% of chiller design tonnage of 44% of peak unit KW's.

For 80% of the time during single compressor operation, this series produces ultra high efficiency performance with 100% compressor standby, additionally its output capacity can be reduced down to 5% of maximum without loss of efficiency.

Operating at 40% of design tonnage a conventional single compressor chiller may draw 35% of peak KW, under similar conditions the one operating compressor of the Westinghouse dual unit will consume only 30% over the full capacity range, and annual operating hours. This feature can result in 20% energy saving.

Many other energy and operating saving features have been designed into the Westinghouse chillers. Either compressor can be isolated and serviced while the other remains in operation. During periods of high cooling, a load balancing control divides the cooling and power consumption between the two compressors, and when just one can meet the demand, each is sequentially switched into service. To ensure that this chiller series maintains

continuing high operating efficiency the Westinghouse patented fuel guard automatically cleans condenser tubes, eliminating the need for periodic shut down for servicing.

**Delta RA**

Delta RA Ltd. is this year celebrating its Golden Jubilee. During these years quality and reliability have been the cornerstone of RA's continued expansion. The products are backed by our Technical and Development department.

Our factory is considered to be one of the most modern in Europe. Investment on a continuing basis has been made on various items of machinery and capital equipment, including our own electrostatic paint plant, and numerically controlled platemwork machine. This obviously gives more in house control of the finished item.

A wide product range has been developed, and various ranges of standard units are offered, these include:

**CM Ceiling Mounted Units**  
Units from 3900-127440 Btu/h with four to six fin/inch option. Units are available with electric-defrost, for low temperature application. The range has recently been extended by the addition of CA designated units, with aerofoil fans.

**Low Line Ceiling Mounted Units**  
These are for use where height is a problem. The units project 15" down from the ceiling. Model range 3500-19500 Btu/h electric defrost, are available for low temperature applications. Heaters withdraw from front of unit, thus obviating plug doors, etc.

**Dual Discharge Ceiling Mounted Coolers**  
Model range from 5,900-36,000 Btu/hr with or without electric defrost.

**Product Coolers**  
An adaptable range, which can be made in floor or ceiling mounted versions. Capacity up to 208,000

**PRODUCT REVIEW: REFRIGERATION INDUSTRIAL AND COMMERCIAL**

Btu/h, water or electric defrost, four or six fins inch. Suitable for cooling and freezing with various fan positions.

**Air Cooled Condensers**

Delta RA offer five different condenser ranges specially designed for the refrigeration and air conditioning markets. Three of these ranges cover various duties from 3-100 TR for normal industrial users. In areas where noise is a consideration, we offer a quiet range with capacity from 3-80 TR, if being installed in a particularly sensitive area, residential models are available from 3-65TR, all units are for either horizontal or vertical air flow.

**Special Products**

Coil production to meet specific customer requirements, plays a major part in our manufacturing programme, with all a wide selection/sizes being produced for various cooling/heating media. Several options on materials are available.

The variety of end users, including fruit stores, transportation, brewing, heat recovery, etc.

For further information contact Irish agents, Fridge Spares Wholesale Ltd., 37D Dublin Industrial Est., Glasnevin, Dublin 11, (Tel: 303466/303793).

**Dawe**

Following the announcement of a portable flammable gas detector, the Gazalarm FL10, Dawe Instruments Limited has now introduced a further model the BM14 'Minibalise'.

The Minibalise flammable gas detector offers all the features of the FL10 (simple to use, well constructed, and reliable) but is mounted in a very robust fibreglass casing for outdoor use under adverse climatic conditions. It is also designed for use in the very rugged conditions often encountered by safety and emergency services or in oil rigs, mines and other hazardous working places.

The Minibalise is calibrated in percentage of

Lower Explosive Limit of a specific gas. The two ranges provided can be calibrated to read percentage L.E.L. of two different gases or 50% and 100% L.E.L. ranges for a single gas. The LED display combined with a powerful audible alarm allow the instrument to be used even in pitch darkness. It can operate for up to 40 hours on its built-in batteries and this period can be greatly increased by use of alternative external auxiliary batteries. A wide range of other accessories and options is available.

Like the FL10, the BM14 complies with the latest CENELEC European standards and has been issued with Certificate of Conformity L.C.I.E. 81-6111X.

**Shamrock**

Although heat recovery systems allied to refrigeration equipment are not new,

they have seldom been more than partially effective. Now the Shamrock Air Conditioning company is marketing the Conder Eureka heat recoverer based on the 'Constant Transfer System' which the company claims is technologically the most advanced and efficient available.

Virtually 100% of the waste heat generated is converted into a constant hot water supply, producing important cost savings for both large and modest users of refrigeration who have a need for significant quantities of hot water.

Despite its high technology, Eureka has been designed to be trouble free in installation and operation. Designed as a package unit, incorporating its own storage cylinder, it is simply connected to the refrigeration system and the cold water supply. Eureka equipment is available in a range of sizes to suit all requirements from the aver-

age butchers shop to the major food processing companies. Capacities range from 16 to 900 litres an hour depending on the size and operational time of the refrigeration plant, and the type and quantities of good refrigerated.

Where very large refrigeration plant is operational the Conder Eureka can be equipped with additional storage cylinders to fully exploit the waste heat potential.

Shamrock Air Conditioning Ltd. also provide a variety of financial schemes with Eureka where repayments can be appreciably less than the clients usual hot water bills, therefore savings can be realised immediately the equipment is installed.

The Conder Eureka heat recoverer consists of three main elements: the heating coil, storage cylinder and insulating jacket.

The heating coil works on the 'Constant Transfer System'. A copper coiled pipe allows the cold water and the hot refrigerant to travel in opposite directions.

This steady counterflow transfers the waste heat from the refrigerant to the water. Using this principle hot water is produced within minutes as long as the refrigeration plant is operating. Water flow is created by natural thermo-dynamic forces.

As the water is heated it expands, causing it to move automatically through the pipe system without the aid of pumps. This also means that it will flow at a speed directly related to the heat transferred, ensuring its maximum extraction.

From the coil the hot water enters the top of the cylinder and remains on top — it does not mix with the cold water already there but simply displaces more cold through the system.

The circuit remains closed until hot water is drawn off and is replaced from the usual cold water supply. When the cylinder is completely filled with hot water the refrigerant automatically bypasses the unit so that the plant continues to operate at full power. No



● Dawe Instruments Type BM14 'Minibalise'.

**PRODUCT REVIEW: REFRIGERATION  
INDUSTRIAL AND COMMERCIAL**



**BUTLER REFRIGERATION LTD.**

Turtulla, Thurles, Co. Tipperary

*Products we deal with:-*

Chill and Deep Freeze Coldrooms  
 Display Units and Deep Freeze Units  
 M.K. Beer Cooling System  
 Icemakers  
 Whipped Ice Cream Machines and Ice Cream Freezers  
 Supermarket Refrigeration and Air Conditioning  
 Hotel and Catering Refrigeration  
 Design and Application Service  
 Maintenance Contracts, Service, Workshop Overhauls.

Telephone: (0504) 22144/22385/22158  
 Limerick Office Telephone: (061) 47229  
 Telex Thurles: 33080

**STAR TURN**

**CROSSFLOW AIRCONDITIONING** supply and install the **UNIQUE LOW PRESSURE RECEIVER SYSTEM** developed by STAR Refrigeration Glasgow.

*Features*

Fully packaged plant. Site time for 500,000 cu. ft. low temperature store:- 2 weeks.

Complete compressor protection.

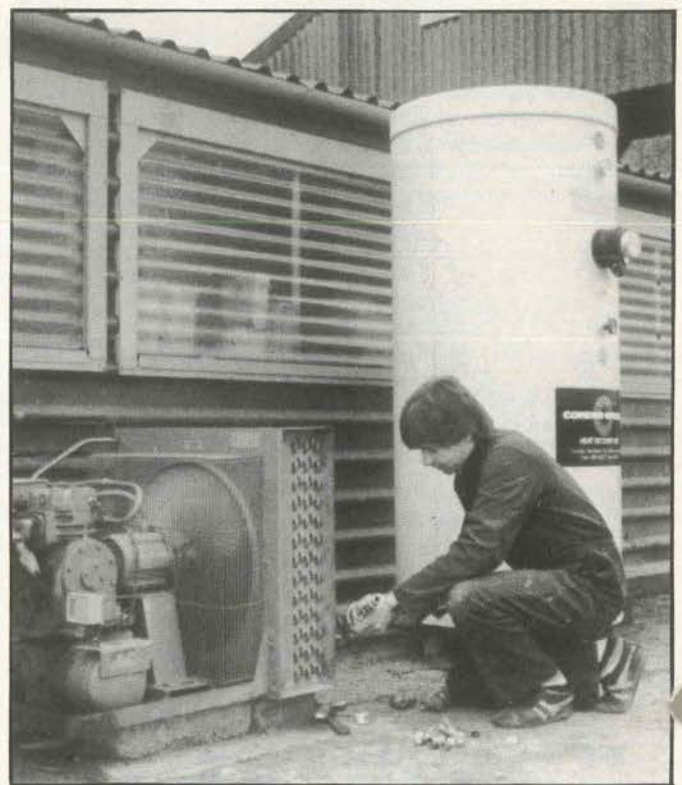
Reliable reverse cycle defrost. Defrost times for the largest evaporators — 7/10 minutes.

High reliability and minimum maintenance attention.

For complete information contact,



Crossflow Airconditioning Limited, Stillorgan, Co. Dublin.  
 Phone: 881607, 881727, 884538. Tlx. 24121.



● A typical Conder Eureka installation from Shamrock Air Conditioning Ltd.

manual switching is necessary.

The steel storage cylinder used in the Eureka has a double enamel lining and is further protected from corrosion by a magnesium sacrificial anod. It also meets the requirements of drinking water installations in accordance with DIN 4753.

A thick polyurethane insulation ensures that the stored hot water retains its heat with a temperature loss of less than 1°C in twelve hours. If hotter than 60°C is required an additional electric heating element can be incorporated to increase the temperature to 90°C. Alternatively the extra heat can be provided by linking the unit to an existing hot water system. A thermometer on the front of the casing provides a visual temperature check.

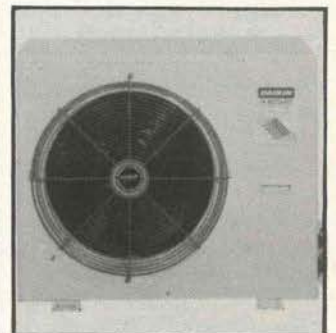
The outer casing is made from impact proof plastic which allows the unit to be installed out of doors without deterioration, provided the pipework is well protected against frost.

With no moving parts, the Conder Eureka needs no special maintenance, even after long use. With

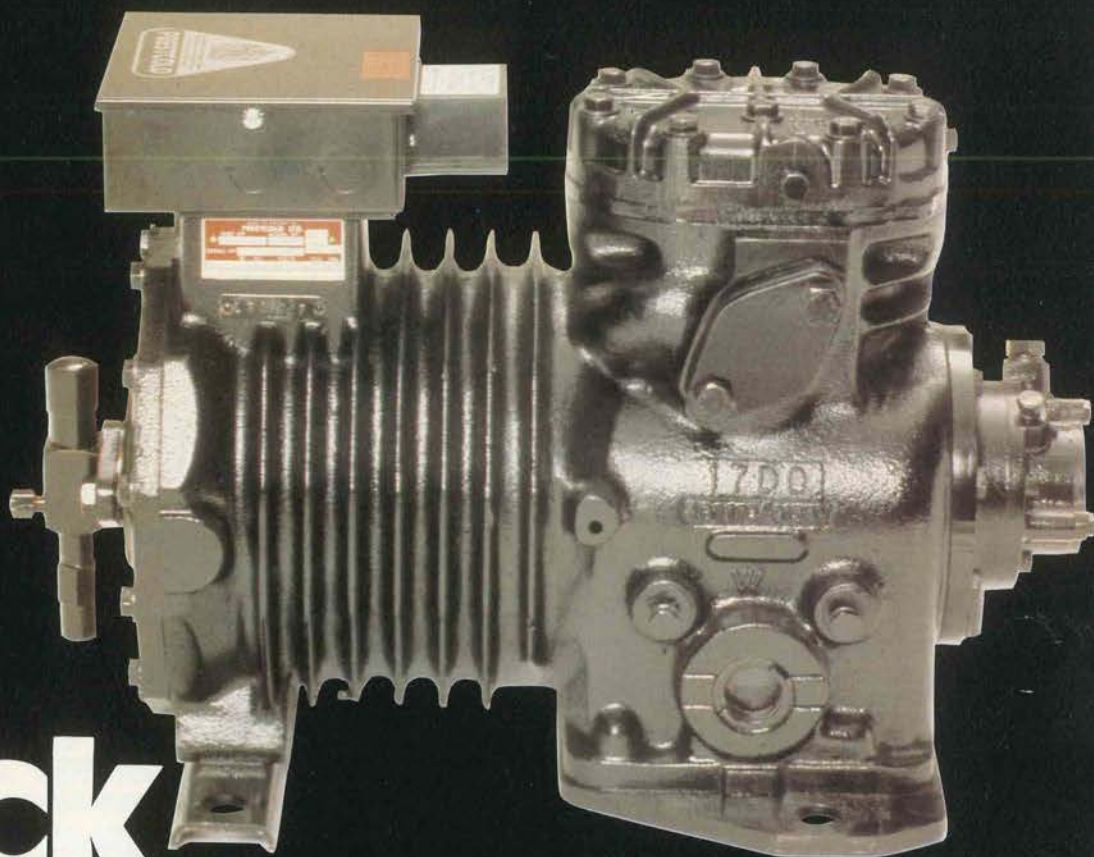
the constant movement of water it is also less susceptible to scaling. The complete unit is guaranteed for a year and the storage cylinder for five years.

**Daikin**

The Daikin condensing units are specifically designed to be connected with various Daikin direct expansion type fan coil units respectively for cooling and are installed outdoors such as on the veranda, balcony or on the roof. Since the Daikin condensing units are extremely com-



● A Daikin condensing unit from Coolair Ltd.



# Black Magic

If you're looking for the best in refrigeration equipment, you could use a little Black Magic from Prestcold.

The Prestcold product portfolio features a comprehensive range of semi-hermetic and open-type compressors and condensing units from 0.33 to 70.00 hp, with the range and performance to cover all applications from low-temperature work to air-conditioning and heat pump installations.

Innovative engineering, energy fitness and traditional Prestcold quality come as standard — so does the confidence you get from dealing with one of the world's leading compressor manufacturers.

From Auckland to Aberdeen from St. Louis to Singapore, discerning refrigeration users have come to count on Prestcold for reliable, trouble-free performance, so why not get Prestcold Black Magic working for you?



## PRESTCOLD

Prestcold Limited, Theale, Reading RG7 4AF, England. Tel: Reading (0734) 302222. Telex: 848326 G.

**PRODUCT REVIEW: REFRIGERATION INDUSTRIAL AND COMMERCIAL**

compact and light, they require only small and narrow space in which the conventional condensing unit cannot be installed.

Further details from Coolair Ltd.

## Danfoss

Danfoss has developed a system of servo-controlled main valves for modulating liquid injection into refrigeration, freezing, and air-conditioning systems. They are called types PMFL and PMFH and are controlled by a pilot float valve.

The system is used for ammonia and fluorinated refrigerants, and the regulators can be fitted in liquid lines to or from e.g. evaporators, separators, intercoolers, condensers, receivers.

The regulators are available in different sizes:

PMFH 70-1740 kW, R12 rated; PMFL 17.4-1050 kW, R12 rated with rated R12 capacities from 12 to 1740 kW.

Danfoss has also designed a new universal solenoid valve which meets all quality and safety requirements. The new valve is

suitable for use on refrigeration, freezing and air conditioning plants. The new series of solenoid valves is designated EVR.

EVR — is a universal solenoid valve, which is equally suitable for use in liquid, suction and hot-gas lines.

EVR — suitable for all fluorinated refrigerants, e.g. R12, R13, R13B1, R22 and R502.

EVR — has a standard coil which can operate with a maximum opening differential pressure (MOPD) of 21 bar. An MOPD of 25 bar is obtained by using a special coil (12W).

EVR — the standard coil is both waterproof (IP 67) and heatresistant (ambient temperature 80°C).

For further details contact Irish agents and distributors J. J. Sampson & Son Ltd., Unit 71, Cherry Orchard Industrial Estate, Dublin 10 (Tel: (01) 268111).

## Prestcold

Prestcold look back with pride on nearly 50 years as one of the major manufacturers of refrigeration

equipment.

The company was founded in 1934 as a division of the Pressed Steel Company to manufacture domestic refrigerators. Although production of domestic equipment ceased in the early 1960's, it is with this product that the Prestcold name is still associated among the general public. Many of those early refrigerators are still in constant use today as testimony to the quality and reliability built into every Prestcold product.

As the cold-chain developed, Prestcold became increasingly involved in the provision of equipment for the commercial production, distribution and sale of refrigerated food products. Prestcold display cases, cold rooms and conservators became an increasingly familiar sight in shops the length and breadth of Britain.

In post war years the Prestcold product range expanded to include compressors, condensing units, display cases and service cabinets. Concentrating increasingly on the commercial side of the refrigeration industry. Prestcold's involvement expanded to cover every aspect of the

business, from the manufacture and sale of refrigeration equipment through plant design and installation to maintenance and service.

Prestcold moved to its present site at Theale, near Reading, in 1951. By 1958 new, high efficiency semi-hermetic compressors had largely replaced the belt-driven open-type compressors in the Prestcold range.

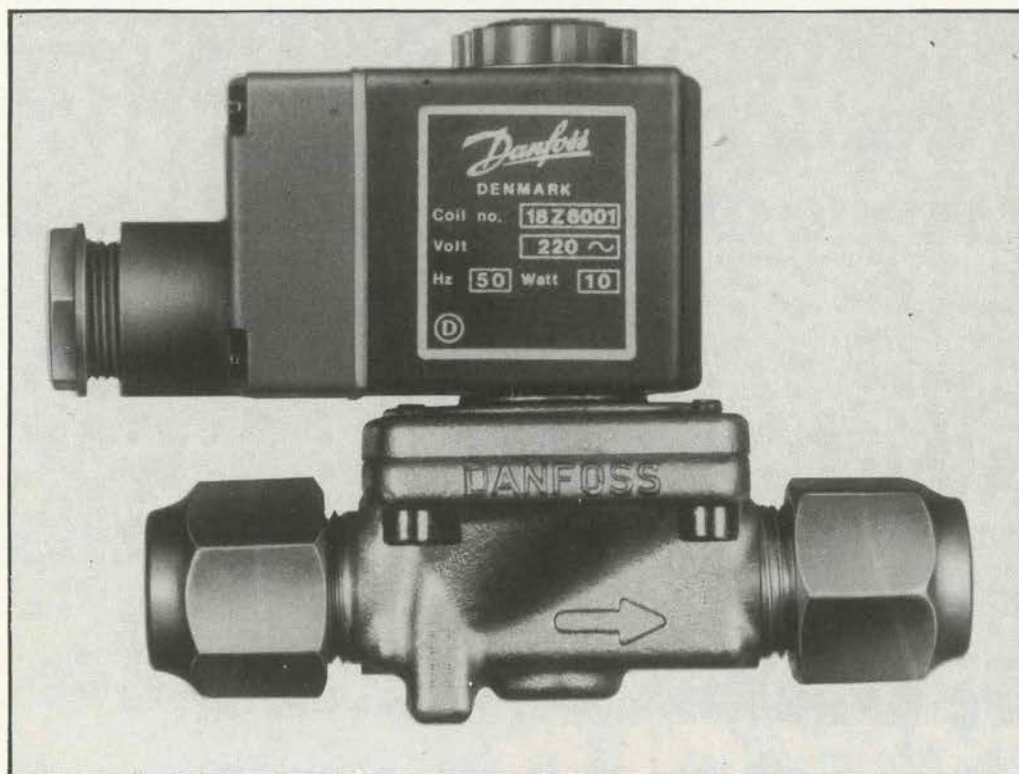
While Prestcold continued to play a major role in the U.K. refrigeration industry the company's attention turned increasingly to growing export markets. A network of Prestcold distributors spread throughout Europe and beyond.

After many years of consistent growth, export sales now account for over 70% of the company's production. Prestcold markets its products through subsidiary companies in Canada, France and the Federal Republic of Germany and through distributors and agents to over 90 countries worldwide. Many of the world's leading refrigeration equipment manufacturers have come to rely on Prestcold for performance, range and reliability.

In the early 1970's Prestcold ceased production of service cabinets and display cases to concentrate exclusively on the manufacture of refrigeration compressors and condensing units. The 1970's also saw the introduction of the six-cylinder 'E' Compressor extending the Prestcold range up to 70 h.p.

In 1980 Prestcold introduced the comprehensive new 'MA' range of air-cooled condensing units from 0.33 to 15.0 and in response to the increasing use of refrigeration compressors for heat pumps unveiled the 'LG' range of suction-gas cooled compressors from 2.0 to 6.5 h.p. specially developed for heat pump and heat-recovery applications.

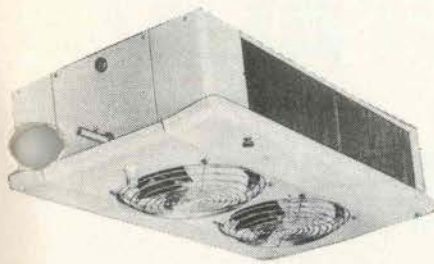
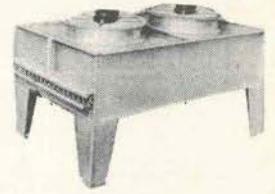
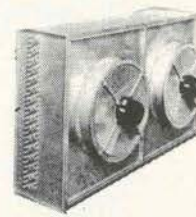
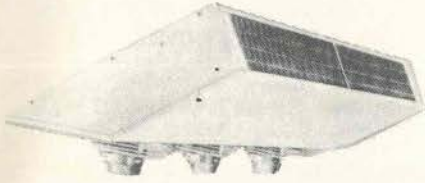
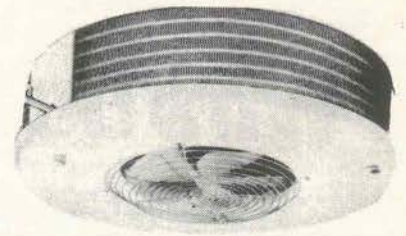
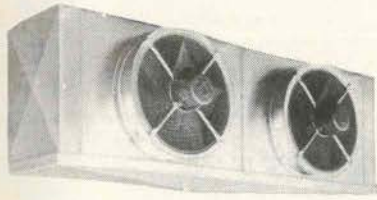
1981 saw the launch of the 'C4' range of four cylinder semi-hermetic and open compressors from 10.0 to 30.0 h.p. The design of this new range represents a radical departure from



● The EVR solenoid valve from Danfoss.

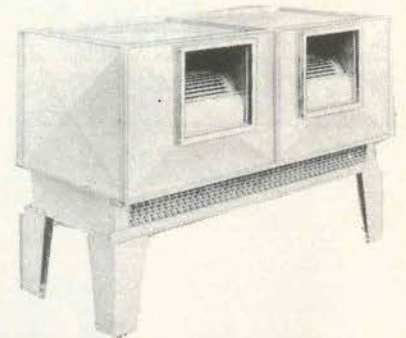


**A COMPLETE RANGE OF  
CONDENSERS AND  
COOLERS FROM WEST  
GERMANY'S LARGEST  
MANUFACTURER**



Available from:

**RSL Group** **RSL Ireland Ltd**  
48F Robinhood Industrial Estate,  
Long Mile Road,  
Clondalkin,  
Co. Dublin.  
Telephone: 508011 Telex: 24818.



**FREE HOT WATER!..**

**From Your  
Refrigeration**

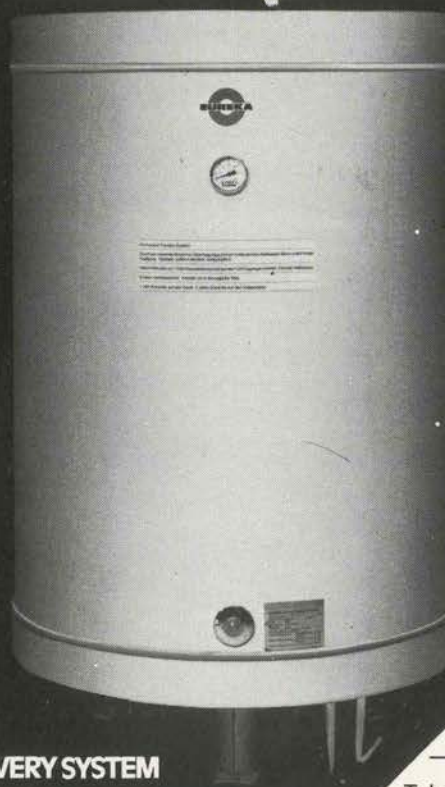
The Conder Eureka heat recoverer is technologically one of the most advanced and certainly the most efficient on the market.

Using the 'constant transfer system' it utilises virtually 100% of the waste heat generated by commercial refrigeration plant and converts it into a constant supply of hot water at around 60°C.

Designed as a complete package unit, incorporating its own storage cylinder, it is available in a range of sizes to suit all requirements. Eliminate your hot water bills — send for more information from:-

Irish Agent:—  
**SHAMROCK  
AIR CONDITIONING LTD.**  
127 Phibsboro Road, Dublin 7. Tel: 304269.

**CONDER-EUREKA**  
HEAT RECOVERY SYSTEM



Low cost  
finance and leasing  
plans available

Name \_\_\_\_\_  
Company \_\_\_\_\_  
Address \_\_\_\_\_  
Telephone \_\_\_\_\_

# Air conditioning running costs don't have to leave you gasping

If a building has a heating/cooling system that's not energy efficient, tightening the belt is sensible housekeeping, but alas, it's closing the stable door after the energy horse has bolted.

So don't just put in a good heating and cooling system – put in one that's been tailor-made for the job. Like Carlyle from Walker, designed for energy efficiency.

A range of more than 4,000 Carlyle air conditioning and heating products means unequalled choice and flexibility. And to help you choose we can offer alternative systems, computer selected for energy efficiency.

We offer the world's biggest range of heat pumps too, each with reversible compressors specially engineered to cope with the wear and tear of heat pump operation. From single-piece to splits, rooftops and you-name-it, Walker has it.

And then there's our latest product, Heat Machine, which is going to make a few boilers redundant in the eighties. It removes heat from waste warm water and by dint of its 2.3 to 6.0 C.O.P. (depending upon the water temperatures involved), produces cheap useable heat for comfort or industrial process use.

Systems that think for themselves? Walker has the answer to that, too. Carlyle VAV systems have terminals that automatically adjust to the heating and cooling needs of the moment – never using more energy than required to deliver the perfect atmosphere.

With all that on offer, what more do you need? The most energy-efficient system to meet your precise needs, the equipment to give you long-lasting reliability – and the pre-and after-sales service that gives you the back-up you need.

With building running costs going through the roof, it's nice to know Carlyle from Walker can help to bring them back to earth.

Carlyle from Walker. Helping to eeze the squeeze.

## **WALKER** **AIR CONDITIONING**

Distributor for Carlyle heating and air conditioning products

DUBLIN: DUBLIN INDUSTRIAL ESTATE, FINGLAS ROAD  
DUBLIN 11 TEL: DUBLIN 300844

BELFAST: 9A CHERRYHILL ROAD, DUNDONALD  
BELFAST BT16 0JH TEL: DUNDONALD 5234

GLASGOW: WASHINGTON ROAD, UNIT 10B  
ABBOTSINCH INDUSTRIAL ESTATE  
PAISLEY PA3 4ET TEL: GLASGOW 887 0551



A member of the Jefferson Smurfit Group

# Generous with our knowledge,



the air conditioning leader

<https://arrow.tudublin.ie/bsn/vol21/iss4/1>  
DOI: 10.21427/D7ZX3B

**mean with your energy.**



## Mosten Engineering Supplies Ltd.

LARAGHCON LUCAN, CO. DUBLIN.

Telephone: 01/282851/592072



Sole Irish Distribution Agent for:

**WILLISON CONTROLS LTD,**

*Exclusive Distributors of*

- **HENRY VALVE**
- **REFRIGERATING SPECIALTIES**
- **GRASSO STACON**
- **STANDARD REFRIGERATION**
- **METREX**
- **A.C. & R. COMPONENTS**
- **PACKLESS**
- **FANAL**
- **C & D VALVE**
- **EGELHOF**
- **PRODUCT ENGINEERING**
- **NOVA**
- **HELPMAN**

- STOP VALVES ● CHECK VALVES ●
- SOLENOID VALVES ● EXPANSION
- VALVES ● BALL VALVES ● 3 & 4 WAY
- VALVES ● PRESSURE RELIEF VALVES ●
- STRAINERS ● PRESSURE REGULATORS
- FLOAT SWITCHES ● OIL LEVEL
- REGULATORS ● GAUGES ● OIL
- SEPARATORS ● ACCUMULATORS ●
- VIBRATION ELIMINATORS ● MUFFLERS
- HEAT EXCHANGERS ● FILTER
- DRIERS ● PRESSURE SWITCHES ●
- THERMOSTATS ● CONDENSERS ●
- EVAPORATORS ●

### PRODUCT REVIEW: REFRIGERATION INDUSTRIAL AND COMMERCIAL

conventional refrigeration engineering practice. The innovative engineering of the 'C4' is backed by substantial investment in some of the most up-to-date computerised production machinery available. The six-cylinder 'C6' from 15.0 to 40 h.p. will be introduced in 1982.

With a comprehensive modern product range, excellent worldwide distribution and unrivalled research and development facilities at its Theale plant Prestcold look back with pride at half a century of service to the refrigeration industry and forward with confidence to the challenge of the future.

ects the day-to-day organisation under service manager Freddie Barber who also is responsible for spares sales. Local service responsibility in the Cork area is held by Neil O'Brien (021-953524) while Kevin McCloat (071-71226) looks after the Connacht region.

The service engineers attend in-house training courses at Group headquarters where advanced refrigeration and air conditioning courses are held.

Spares for Deltaclima and Qualitair packages are available from Rathcoole, as are parts for the well-known former Paracon units on which Deltaclima designs are based.

Substantial stocks of spares are held for Hall, Sterne and Grasso refrigeration compressors and Witt refrigerant pumps. Thermotank Cooling tower fill is another stock item.

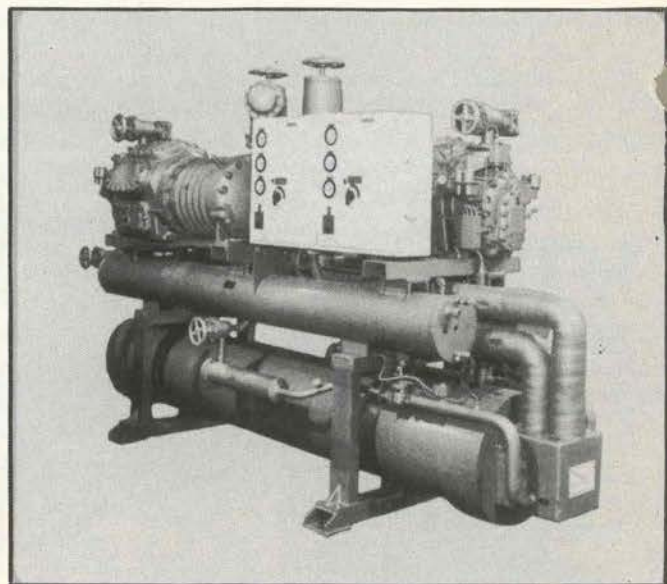
Service work can be speedily attended to on a call-out basis or inspection/maintenance contracts can be drawn up to suit specific requirements.

For further information contact Hall-Thermotank Ireland Ltd., Hall House, Main St., Rathcoole, Co. Dublin (Tel: 580311 Telex 30943).

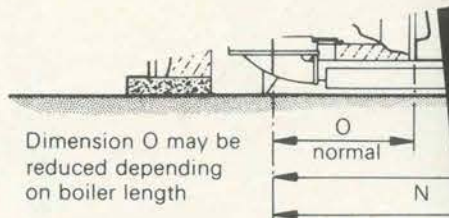
## HTI

As a back-up to the distribution of Deltaclima and Qualitair packaged air conditioning equipment and Hall-Thermotank chillers and cooling towers, Hall-Thermotank Ireland Ltd. provide a substantial service and maintenance function incorporating a large stockholding of spare parts.

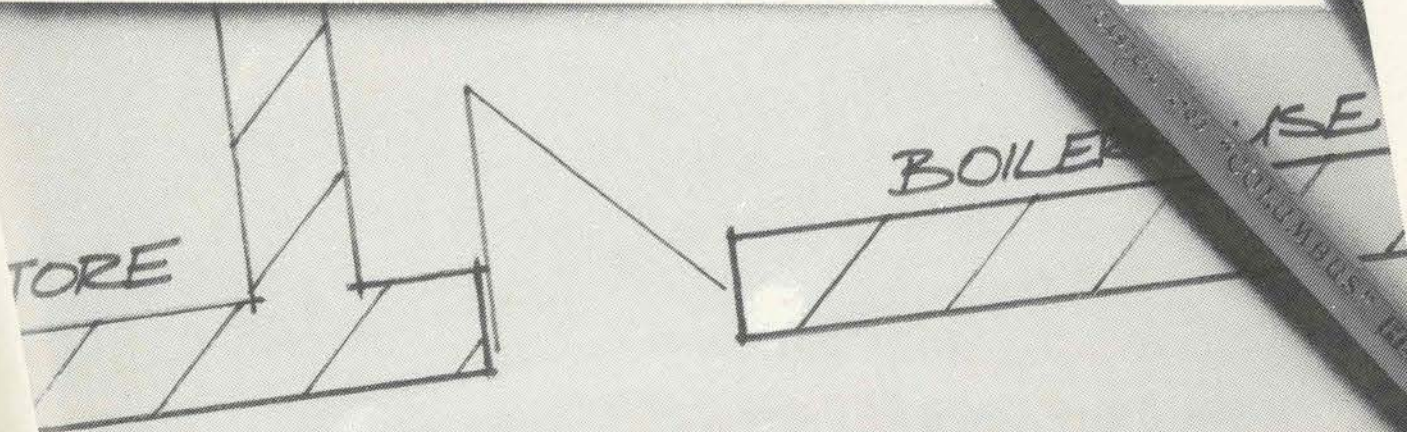
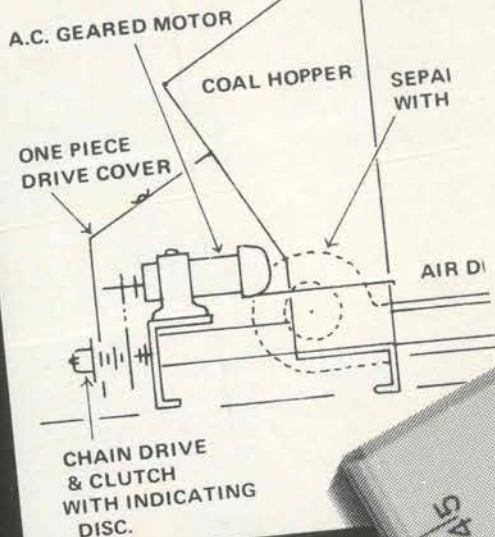
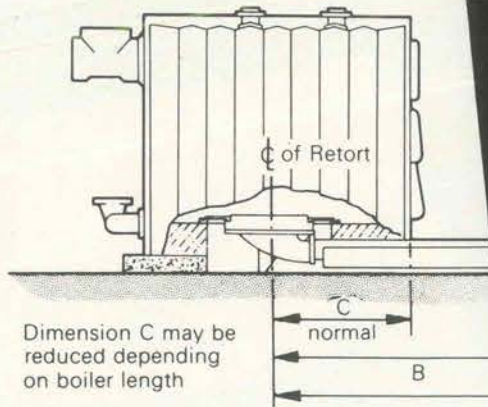
Ten service engineers operate out of Dublin with a further three in Cork and one in Sligo. Service coordinator Frank Healy dir-



● Model PRAN/L from the Hall Thermotank Aquachill range.



Ideal Britannia boiler with stoker (hopper model)



RING MATTHEWS  
 RE: IDEAL STANDARD  
 SOLID FUEL BOILERS  
 AND MECHANICAL STOKERS

**P.J. Matthews & Co. Ltd.**  
 — the plumbing and heating people —

134/135 Lr. Baggot Street, Dublin 2. Phone (01) 789055  
 Matthews Corner, Swords Road, Santry, Dublin 9.  
 Phone (01) 373606

Johnstown, Ballytruckle, Waterford. Phone (051) 72171/4  
 Tipperary Road, Ballysimon, Limerick. Phone (061) 43402



AN ENGLISH ROSE  
SURROUNDED BY SWEETBRIER.

SHOWN HERE IN SWEETBRIER:  
SHERATON BATH, MAYFAIR BASIN, W.C. AND BIDET WITH  
GOLD-PLATED STARLITE FITTINGS, MATCHING BRIER TILE

Sweetbrier is one of the most winning bathroom designs to happen in a long time.

We've taken the warmth and beauty of our new Champagne shade and added an enchanting floral border which sets it off perfectly... with co-ordinating accessories in Champagne and matching Brier tiles - specially created to give you a complete co-ordinated bathroom.

Only Armitage Shanks' entire range of luxury fittings can make such beautiful bathrooms possible.

And our superbly produced bathroom design folder tells you all you need to know.

For your free copy, post the coupon today.



PLEASE SEND ME MORE DETAILS OF YOUR LATEST RANGE OF BATHROOMS AND COLOURS.

NAME

ADDRESS

TELEPHONE

**armitage shanks**

THE ONE YOU KNOW BEST.  
Armitage Shanks (Ireland) Ltd.,  
Cookstown Industrial Estate, Tallagh93  
Co. Dublin