

2-1-2000

## BS News

Follow this and additional works at: <https://arrow.tudublin.ie/bsn>

 Part of the [Civil Engineering Commons](#), [Construction Engineering Commons](#), and the [Construction Engineering and Management Commons](#)

### Recommended Citation

(2000) "BS News," *Building Services News*: Vol. 39: Iss. 2, Article 1.

doi:10.21427/D7DM7S

Available at: <https://arrow.tudublin.ie/bsn/vol39/iss2/1>

This Article is brought to you for free and open access by the Journals at ARROW@TU Dublin. It has been accepted for inclusion in Building Services News by an authorized administrator of ARROW@TU Dublin. For more information, please contact [yvonne.desmond@tudublin.ie](mailto:yvonne.desmond@tudublin.ie), [arrow.admin@tudublin.ie](mailto:arrow.admin@tudublin.ie), [brian.widdis@tudublin.ie](mailto:brian.widdis@tudublin.ie).



This work is licensed under a [Creative Commons Attribution-NonCommercial-Share Alike 3.0 License](#)

# BSN News

MECHANICAL & ELECTRICAL BUILDING SERVICES



## The Energy Show 2000

Dates: 17 & 18 May 2000  
Venue: RDS Industries Hall

◆ **Masterair – 8-page Profile**

◆ **Pumps & Circulators**

# Innovation in Pumping Technology



MVi



MHi

Stainless Steel Vertical and Horizontal multistage pumps for water supply, boosting, sprinkling, irrigation, high pressure wash, fire protection and water treatment (De-mineralisation, Filtering).

- Water supply
- Boosting
- Sprinkling
- Irrigation
- High pressure wash
- Fire protection
- Water treatment
- Boiler Feed

**WILO**  
Pumping-Perfection

WILO Engineering Ltd., Enterprise Centre  
Childers Road, Limerick, Ireland

Telephone: 061-41 09 63 Telefax: 061-41 47 28<sub>2</sub>

# BSNews\*

MECHANICAL & ELECTRICAL  
BUILDING SERVICES

ISSN 0791-0878

Published by:  
Pressline Ltd,  
Carraig Court,  
George's Avenue,  
Blackrock, Co Dublin.  
Tel: 01-288 5001/2/3  
Fax: 01-2886966  
ISDN: 01 - 211 2338/9  
eMail: bsnews@pressline.ie

**Editor:** Pat Lehane  
**Advertisement Manager:** Joe Warren  
**General Manager:** Edel Burke

**Origination and Design:**  
Pressline Ltd. Tel: 01 - 288 5001

**Subscription:** One Year — £27

**Printed by:** Kilkenny People.

© All editorial contents and all advertisements prepared by the publishers, Pressline Ltd.

\* Incorporating Irish Heating & Ventilating News.

## Readership Data

Irish Building Services News (formerly Irish H&V News) is Ireland's only Building Services magazine providing coverage of heating, ventilating, air conditioning, refrigeration, sanitaryware, plumbing, maintenance and environmental industries. It is the only publication catering exclusively for these industries and its circulation includes members of the following:- Chartered Institution of Building Services Engineers (CIBSE);

• Mechanical Engineering & Building Services Contractors' Association (MEBSCA); The Association of Consulting Engineers of Ireland (ACEI); The Mechanical Engineering Contractors' Association; The Institute of Domestic Heating Engineers (IDHE); The Registered Heating Contractors Association; The Maintenance, Energy & Environmental Technology Association (MEETA) which incorporates energy managers and maintenance managers; The Energy Conservation & District Heating Association; The Institute of Plumbing; The Irish Home Builders Association (IHBA); Builders Merchants/Trade Supply Outlets; Irish Property & Facilities Managers Association.

In addition, Irish Building Services News circulates to independent building services contractors and key executives in industry. Government, Semi-State and local authority bodies. Essentially, our circulation is virtually saturation coverage of all those with an interest and/or involvement in the industry.

## It's Showtime!

Over the coming months the building services sector will be spoiled for choice when it comes to specialist trade exhibitions. Both at home and abroad, the industry will be presented with an unparalleled opportunity to view all the latest new product introductions, along with emerging trends and the direction of various market segments.

Make a point of getting to as many as you can. Making the excuse that you are too busy simply is not good enough ... you cannot afford to miss any opportunity which will help you provide a better, more comprehensive service to you client base. Indeed, making time today to visit a show could very well help you save time — and deliver a more professional service — tomorrow.

Make a note of these dates in your diary and see inside for further details on each.

Event	Venue	Dates
Our House	The Point Depot, Dublin	2 to 5 March
Building Services Show	Red Cow Hotel, Dublin	7 & 8 March
Intermat 2000	Paris-Nord	16 to 21 March
Light & Building	Frankfurt	20 to 22 March
Mostra Convegno	Milan	21 to 25 March
Energy Show 2000	RDS Industries Hall, Dublin	17 & 18 May
Natmaint 2000	RDS, Dublin	24 & 25 May

## IN THIS ISSUE

Trade News	2
Mostra Convegno Expocomfort	9
Energy Show 2000 – Making Sustainable Energy Pay	10
Energy Efficient Motors Could Save £45 million Anually	12
ECL Comfort from Danfoss	14
Masterair 8-page Profile	15
Pumps and Circulators	23
SiBS™ – Trusted Service Under a New Name	35
RVR – The Energy Technology Specialists	36

## Irish V-Condenser Helicoptered in place in Switzerland

Thermal, the Drogheda-based condenser and dry-cooler manufacturer, recently delivered a large 10-fan V-Condenser to a major customer in Switzerland by helicopter. The condenser actually travelled by road to Switzerland but was placed in position by helicopter.

Swiss safety regulations required the public to be informed by leaflet one week in advance that anything loose which might be disturbed by the helicopter, such as rubbish bins or gates, should be tied down or removed to a safe place. Naturally, no one was allowed in the streets below, or even on any

overlooking balconies. With all this preparation, a just-in-time delivery was needed so that the helicopter could lift the V-Condenser into place.

Where space is limited, a V-Condenser or dry cooler can provide up to 45% more capacity for the same footprint as a conventional condenser or dry cooler. The Thermal V-Condenser range extends up to 12 fans with a maximum capacity of 1,596kW under Eurovent conditions.

Thermal Heat Exchangers (Irl) Ltd has manufactured heat exchangers in Ireland for over 20 years. The V-Condensers and dry-coolers are the latest addition to

the Thermal range of air cooled condensers and dry air liquid coolers. These products were originally produced in Germany and have been manufactured in

Ireland since 1999.

Contact: Mary Johnston, Thermal Heat Exchangers.  
Tel: 041 - 9831051;  
Fax: 041 - 9832117;  
email: thermal@indigo.ie

## PFP Building State-of-the-Art Premises

PFP Ltd, the Cork-based distributor of heating products, bathroom equipment and industrial fasteners, is constructing a new, purpose-designed office, warehouse and distribution depot in Carrigaline, Co Cork, from where it will feed its fast-expanding business throughout the country.

Since the company was first established in 1981 it has experienced sustained growth year on year. However, in recent years — and especially over the last 12 months — this growth pattern has gathered significant momentum, thereby necessitating the move.

Fitting out of the new premises is currently taking place and it is envisaged that PFP will move over the coming months. Additional staff are being recruited while the extensive range — which already includes Firefly radiators and towel rails; Olympia shower products and bathroom accessories; Soteco wet and dry vacuum cleaners; and an extensive range of industrial fasteners — will also be expanded.

Head office is in Cork with Martin McKeon, PFP Regional Sales Manager for the Greater Dublin area operating out of Dublin and John Scary, PFP District Sales Manager, based in the West of Ireland.

Contact: Jim Barry, Marketing Director, PFP.  
Tel: 021 - 961823; Fax: 021 - 021 317399; email: pfp@indigo.ie

## An American Pipe Dream

Three years and thousands and thousands of hours of testing later, Quality Plastics got to realise their very own American pipe dream ... they waved off the first shipment of their Qual-PEX Plumbing & Heating Pipe to the USA. While Quality Plastics has been exporting this and other products all over Europe, and even as far east as Bahrain, this was the first ever voyage to "The New World".

It is hoped that it is the first of many US pipe dreams for the company. The product has trialled very well in the US where it is perceived as quite unique — so much so that a very large distributor based in Michigan City, has taken on the product for all their underfloor heating applications.

Contact: Karen Horgan, Quality Plastics.  
Tel: 021 - 884700; Fax: 021 - 884701; email: qpl@qpl.ie

## Technology, a Gallon of Whiskey and All That Jazz!

Taking place at the Red Cow Hotel, Dublin, on Tuesday and Wednesday, 7/8 March, The Building Services Show will exhibit products and systems the commercial and domestic building services sector have to offer.

Organised by McCann McGuirk Presentations, The Building Services Show offers visitors the opportunity to assess and compare a broad spectrum of equipment, materials and services from major suppliers. See advances in the development of energy-efficient products and applications designed to provide healthier living and working conditions, with minimum impact on the environment.

As the complete integration of heating, ventilating and air conditioning systems for offices, factories and homes becomes an increasingly-important priority, the need to keep up with the latest concepts in energy-efficiency control and design is greater than ever.

In addition to meeting with suppliers and discussing business solutions face to face, visitors at lunchtime can enjoy a complimentary lunchtime snack, as well as a jazz and cocktail reception on Tuesday evening.

There will also be a free draw for a gallon of whiskey! The Building Services Exhibition runs from 11am to 3pm and 5pm to 8pm on Tuesday, 7 March; and from 11am to 3pm on Wednesday, 8 March.

Contact: McCann McGuirk Presentations.  
Tel: 01 - 453 2497; Fax: 01 - 454 4179.

## BSS Rycroft Alliance

During a whistle-stop tour of Cork recently *BSNews* met with Michael Quinlan, Area Director, BSS Ireland based in Cork, who informed us that the company has formed a strategic alliance with Rycroft Process Solutions, a leading supplier of high-quality packaged systems for process equipment.

"We used to build our own", said Michael, "but being associated with Rycroft means we can now offer a more streamlined, professional service, supported by a wider range and extensive system design and technical support".

Rycroft Ltd is based in the UK and the company's history dates back to 1899 when it was known as Rycroft and Metcalfe, a plumbers merchants, which



Rycroft Process Solutions from BSS offer a complete package option to industry.

later added coppersmith, tinsmith and brass-finishing departments, along with the acquisition of a foundry.

Technology has advanced significantly in both the design and manufacture of heat exchangers and calorifiers at Rycroft Ltd, especially in the last five years. In design, the drawing board has been discarded and a computer-

aided draughting system installed. Computer programmes are now used to design heat exchanger batteries, pressure vessel thicknesses, manufacturing labour times, pressure vessel volumes, and programmes are being used to estimate costs and take listings of parts directly from computer-generated drawings.

Rycroft has implemented a BS 5750 system and is now BS EN ISO 9001 : 94 approved. Further modernisation is currently underway to develop the company further and take it well into the 21st century. This includes major investment in plant equipment, computer software and, of course, personnel. Additional developments which include electronic data transfer systems and 3-dimensional modelling are also part of the forward-planning strategy to further establish Rycroft as a market leader in heat exchange and heat exchanger packages.

Contact:  
Michael Quinlan,  
BSS Ireland.  
Tel: 021 - 321588;  
Tel: 021 - 621595.

## Potterton Myson Sold

Blue Circle Industries PLC has sold its European heating business (including Potterton Myson) to Baxi Partnership for Stg £475 million. The rationale behind this sale was that Blue Circle wished to focus on its worldwide current business.

Baxi Partnership in turn has agreed to sell the radiator division of Blue Circle, including Myson, to Rettig Heating Group (subject to competition authority approval). Again the rationale is that they wish to focus on boilers only.

As a result of the above acquisitions, Baxi became one of Europe's largest boiler manufacturers and Rettig will become Europe's largest radiator manufacturer.

Potterton Myson Ireland is continuing to offer the same high level of support across all products (boilers, rads, valves, pumps, etc) as before.

## Ventac Seeks Stockists

Ventac Ltd, distributor of ventilation equipment and ancillaries, is looking to appoint stockists in the North-West, West, South-West and South of the country.

Interested parties should contact Ciaran King at  
Tel: 01 - 667 1077;  
Fax: 01 - 667 1055;  
email: info@ventac.ie  
Website: www.ventac.ie

## Intermat 2000, Paris

With months to go before the exhibition opens its doors, Intermat 2000 (16 to 21 May 2000, Paris-Nord) is already showing clear signs of exceeding all forecasts. So that it can welcome all the companies already registered, plus those who have announced their intention to participate, Intermat 2000 is expanding into an additional hall.

The new Hall 4 will be set aside for equipment and technology aimed primarily at construction firms (small site equipment, concrete mixing, scaffolding, demolition, safety, etc).

This expansion is evidence of the extent to which Intermat has opened up to the construction sector. Mechanisation is undoubtedly a major concern for construction firms faced with the increasingly restrictive demands of the marketplace. These firms also need to know about the most efficient equipment and methods in terms of safety and environmental protection.

The gross surface area of exhibition space at Intermat 2000 is now 290,000 sq m and encompasses Halls 4, 5, 6 and 7, an outdoor exhibition area, plus a demonstration area where exhibitors are able to show their equipment working.

Special travel/accommodation package -  
Co-Operative Travel. Tel: 01 - 456 4588; Fax: 01 - 450

TRADE NEWS

## Acoustical Curtain Systems

Sound Seal™ acoustical curtain systems offer an effective, economic method of noise reduction in a wide variety of industrial, architectural, and OEM noise control applications. Acoustical curtain systems can be configured to create total enclosures, partial enclosures, hoods or shrouds, barrier walls and divider partitions.

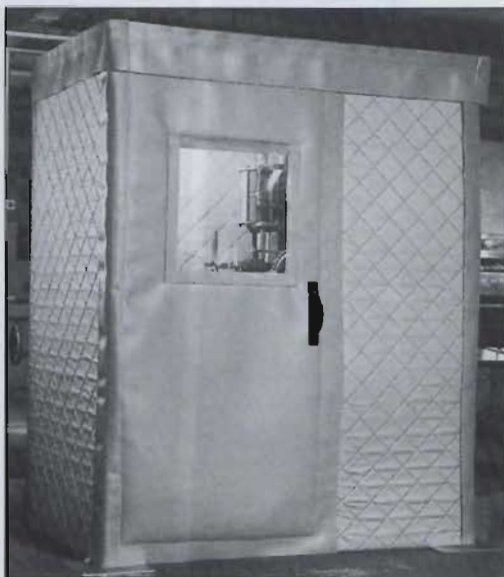

SONEXcurtain Enclosure System™ from Noise Control Research Laboratories Sound Seal Division.

## Our House 2000

Our House 2000 takes place in the Point Depot from 2 to 5 March next.

This year sees a new focus and direction in the form of Gardening 2000. To date gardening has had a reasonable representation at the event with companies displaying timber decking and garden furniture, and the organisers believe that this is the opportune time to expand and develop this area.

The Our House Exhibition is now in its fourth year and enjoys an attendance in excess of 30,000 paying visitors. With this year's expanded coverage that figure will undoubtedly be surpassed.

Contact: Linda Ronan, Event Administrator.  
Tel: 01 - 624 5120;  
Fax: 01 - 624 2202.

## Liquid-Free Pressure Gauge

The 8 1/2" face of the new Dwyer Series 7314D spirahelic® pressure gauge from Manotherm features an easy-to-read, mirrored analog display and a bond 4 1/2 digit LCD. The gauge's 0.25% FS accuracy (ASME Grade 3A) results from its unique direct-drive design, which connects a sensitive, yet vibration-resistant, triple-helix Bourdon tube (of Inconel® X-750 alloy) to a precisely-balanced pointer. This simple design eliminates gears, springs and linkages, which are subject to wear, diminished accuracy and premature failure. It also eliminates the need for messy dampening liquids.

The gauge's 316 stainless steel connection block has two 1/4" NPT female ports (one on the back, one on the bottom) for easy bottom or back connection. ASME B40.1 design fits standard 9" (229mm) cutouts. The gauge's solid front case, rear blowout panel and low-volume Bourdon tube all assure safety.

Over-pressure protection is 150% of full scale. An integral filter plug keeps out dirt.

Requiring no lubrication or periodic servicing, the Series 7314D spirahelic pressure gauge is available in four models, covering ranges from 0 - 100psi to 0 - 600psi.

Contact: Bob Gilbert/  
Brian Harris,

Manotherm. Tel: 01 - 452 2355; Fax: 01 - 451 6919;  
email: manotherm@eircom.com

Photo shows Dwyer Series 7314D spirahelic pressure gauge from Manotherm.

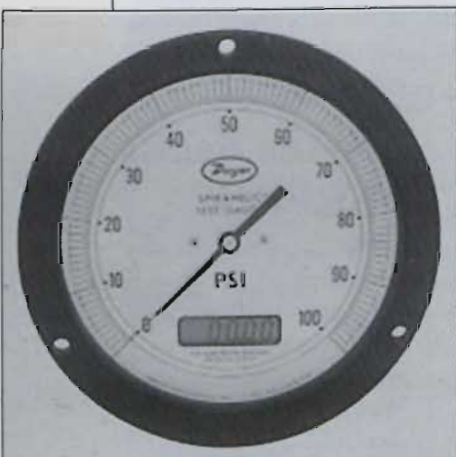

A wide variety of Sound Seal acoustical curtain panels and curtain support framing options are available from Noise Control Laboratories Ltd, a wholly-owned subsidiary of Ventac.

Contact: Noise Control Research Laboratories, Sound Seal Division.  
email: sales@soundseal.com  
Website: <http://www.soundseal.com>  
email: ctking@ventac.ie  
Website: [www.ventac.ie](http://www.ventac.ie)

## Natmaint 2000

Natmaint 2000, the national maintenance and facility management exhibition, takes place in the RDS Dublin from 24 to 25 May. It will cover every aspect of this increasingly-important industry sector and will be attended by decision-makers from industrial, property management and public facility sectors in search of efficient maintenance and facility management products and services.

Ireland is now one of the most popular locations for large multinational production companies such as Intel, Hewlett Packard, IBM, and many more. Between these large companies and other facilities, such as shopping centres, hotels and apartment blocks, more than £1.5 billion is spent each year in Ireland on maintenance and facility management.

Contact: Helen Clarke, Exhibition Director.  
Tel: 01 - 405 5551; email: [helen@sdlexpo.com](mailto:helen@sdlexpo.com)

# Thermo Systems

## JOHNSON CONTROLS

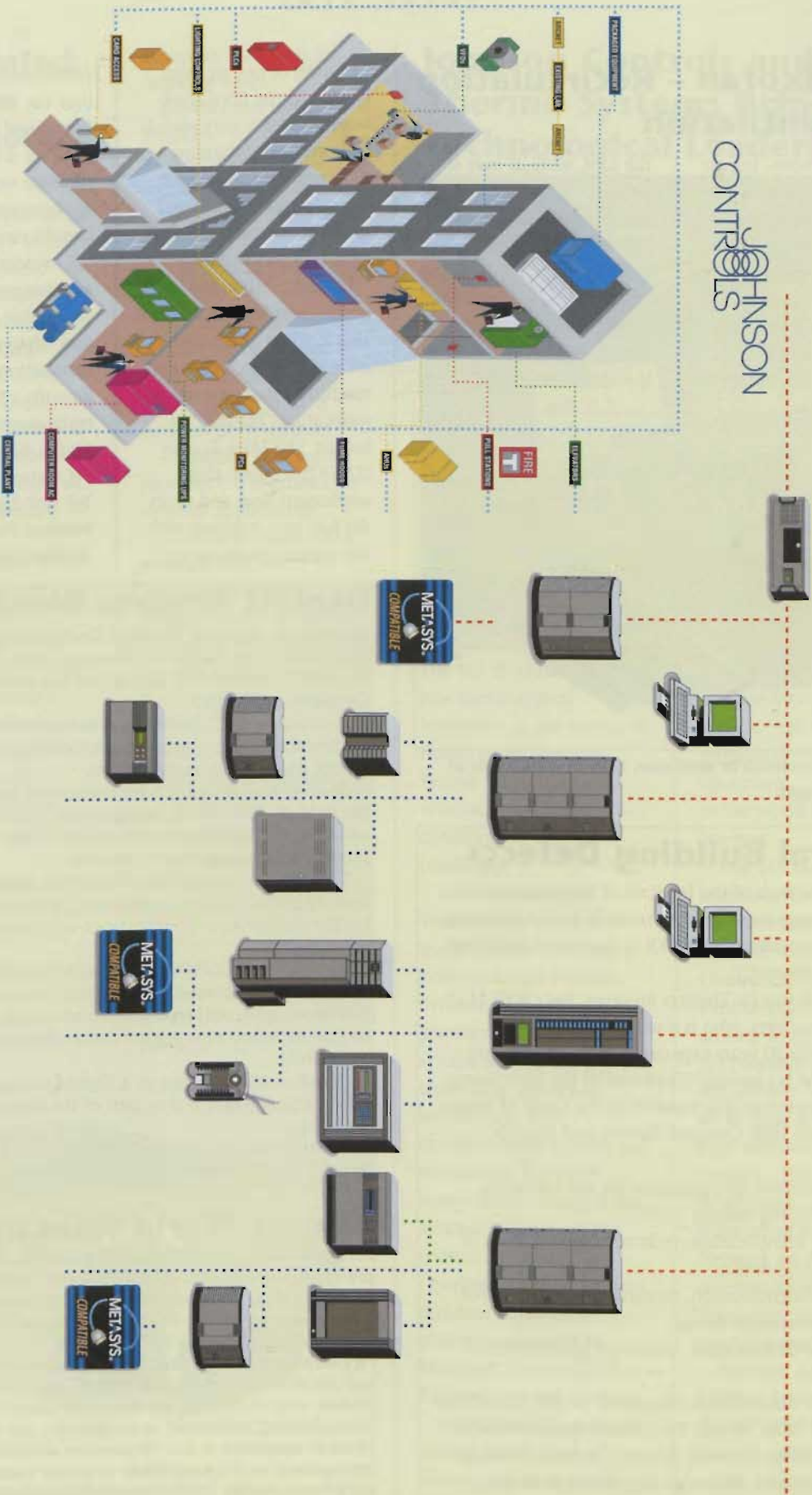

## JOHNSON CONTROLS

Thermo Systems

# Your BMS and Controls Systems specialist

Thermo Systems Limited  
 Whitechurch Road, Rathfarnham, Dublin 14, Ireland. Phone: +353 1 493 1701. Fax: +353 1 493 1746. E-mail: [info@thermosystems.ie](mailto:info@thermosystems.ie)



TRADE NEWS

## Mark Ecofan – Recirculation and Ventilation

As everyone knows, hot air rises. What is less well known is that this natural phenomenon can be a real nuisance, especially say, when trying to heat a large hall. In winter it may well be uncomfortably hot immediately underneath

the roof, while it may still be freezing at floor level. The temperature difference between top and bottom can be as much as 20°C.

By providing adequate recirculation, the Mark Ecofan (W42/W82) reduces this difference to 3°C. Such

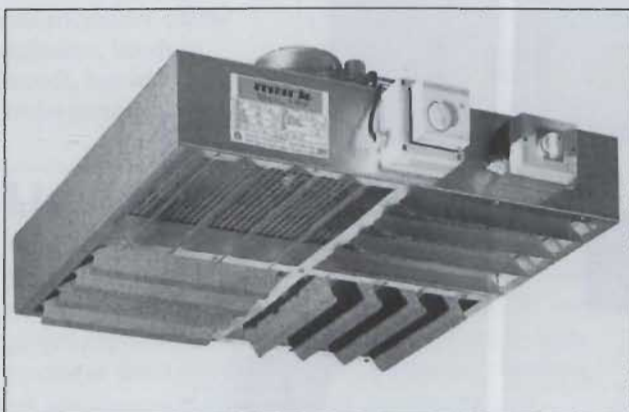

Whether its recirculation or ventilation, Mark's Ecofan meets all needs, economically.

a transfer of hot air from the top to the floor-level working area is very useful. It shortens the warming-up time and reduces heating costs. In tightly-insulated spaces it also provides the necessary air circulation.

In summertime the Mark Ecofan is at least as useful. This is when "heat sources" such as the sun, lights and machinery can generate a suffocating "blanket" of hot air. The Mark Ecofan (Z/W42) removes this unpleasant heat and vents the hot air – together with any contained smoke or

other noxious vapours – into the atmosphere. Combined with a supply of fresh air it helps create pleasant work environments which benefit productivity.

Considering these advantages along with the favourable purchase price and relatively low installation costs, moving air with a Mark Ecofan is really economical", says Mark's Roger Bolger.

Contact: Roger Bolger.  
Tel: 087 2592099;  
Mairiad Twomey.  
Tel: 026 45334; Fax: 026 45383.

## General Building Defects

The Dublin Branch of the Institute of Maintenance & Building Management (IMBM) recently held a technical evening in association with TKB & Associates (buildings defects consultants).

The speaker was Dr Thomas Brennan, Bsc CRST, M.D of TKB & Associates, who is a recognised master craftsman with 20 years experience as a conservation contractor. He is currently Chairman of the Irish Damp Proofing Association and member of the Guild of Master Craftsmen and Irish Georgian Society and English Heritage.

The presentation gave guidance on the following aspects of building defects:

- Analysis, identification, treatment specification of various fungal growths;
- Analysis, identification, treatment specification of rising and penetrative damp;
- Analysis, identification, treatment specification of insect attack.

Among the many TKB & Associates' project and clients are Office of Public Works; Presidential Palace, Phoenix Park; The Heritage Council; Loretto Convent Buildings throughout Ireland; Ballymun Regeneration Project; Temple Bar Properties; and numerous churches, chapels and castles.

## Danfoss Acquires Woodley UK

Danfoss has acquired Woodley Electronics Group, whose headquarters are located in Wantage, near Oxford in England. It employs 70 people and has sales companies in Germany and France.

Founded in 1977, it develops, manufactures and supplies electronics for the control and monitoring of refrigeration plants, particularly supermarkets.

Danfoss and Woodley have cooperated for many years in the field of ADAP-KOOL refrigeration controls, creating solutions for big supermarket chains in the UK. The systems were integrated at Woodley.

Through the acquisition of Woodley, Danfoss extends its leading global supplier positioning of electronics solutions for the control and monitoring of refrigeration plants of supermarkets.

Woodley's products, together with Danfoss' electronic controls manufactured in Nordberg, Denmark as well as Baltimore, USA, will represent an attractive product range to international supermarket chains that are expanding worldwide.

Woodley will continue as a limited company within the Danfoss Group and is now part of the Automatic Controls Division.

Contact: Danfoss (Ireland). Tel: 01 - 626 8111;  
Fax: 01 - 626 9334. email: sampson@ndigo.ie

## Lennox World Sales up 30%

In remarks made earlier this week at a meeting of industry trade press representatives in Dallas, John Norris, Chairman and Chief Executive Officer of Lennox International Inc, said he expects Lennox' sales for 1999 to be about \$2.4 billion, representing an increase of approximately 30% over 1998.

"It's exciting to be associated with a company over a century old and still showing such dynamic growth", said Vincent Mahony of Walkair, who are the Irish distributors for Lennox.

Selling heating, ventilation, air conditioning and refrigeration (HVACR) equipment in over 70 countries worldwide, Lennox International Inc is a world leader in climate control solutions. It is the parent company of Lennox Industries Inc, Armstrong Air Conditioning Inc, Heatcraft Inc, and Lennox Global Ltd.

Contact: Vincent Mahony, Walkair. Tel: 01 - 456 8070; Fax: 01 - 456 8090; email: walkair@walkair.ie

## Pre-Insulated One-Piece Water Storage Tanks

The Balmoral Royale range of one-piece water storage tanks is manufactured using medium-density polyethylene and complies with the requirements of Byelaw 30 of the Water Supplies Byelaw Guide. The Royale is factory insulated and its smooth surfaces discourage the infusion of light and the possibility of algae promotion.

The Royale is produced using a highly-effective closed-mould process which ensures excellent dimensional stability and consistency of strength. Other manufacturing techniques depend upon high skill levels and intensive inspection to ensure repeatable quality products.

The Royale can be safely used for the domestic and industrial storage of cold potable water and recognises new requirements for water quality embodied in the

European Standards for drinking water.

- Benefits and features include:-
- One-piece moulding provides a seamless unit;
  - Standard 50mm thick insulation;
  - Rigid close fitting cover included;
  - Provision for positioning of fittings;
  - Manufactured from lightweight, corrosion resistant polyethylene;
  - Standard grey colour provides UV resistance for external applications;
  - Excellent impact and abrasion resistance;
  - Complete with screened manway access compliant with Byelaw 30;
  - Extensive range of standard sizes;
  - WRc approved;
  - Leak-free and minimum maintenance;
  - Avoids use of mechanical reinforcement.

Contact: John Brophy, BSS Ireland (Dublin).  
Tel: 01 - 454 1966;  
Fax: 01 - 454 1017;  
Michael Quinlan, BSS Ireland (Cork).  
Tel: 021 - 321588;  
Fax: 021 - 321595.

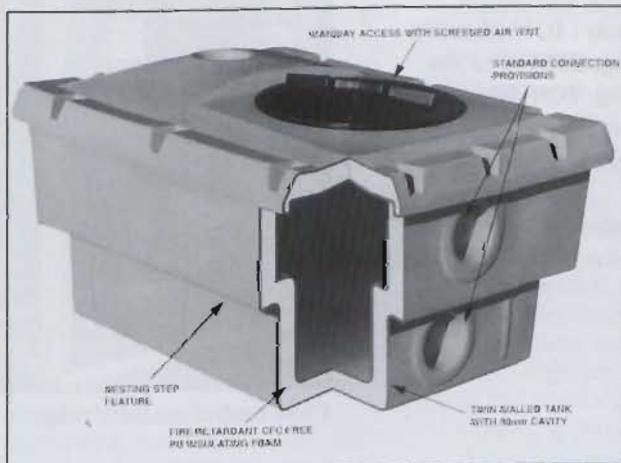

Balmoral Royale pre-insulated one-piece water storage tank from BSS Ireland.

## Johnson Controls and Thermo Systems Bring New Technological Leadership



The M5 Workstation brings new technological leadership to the Metasys® Building Management System for heating, ventilating and air conditioning control of buildings.

Metasys Operator Workstations are easy to use. Operators can simply point and click through dynamic, full-colour graphics of floor plans, system schematics, live trend data, historical information and comprehensive reports and summaries. You can interactively change status, schedules, setpoints and control strategies. The Operator Workstation uses standard hardware platforms and runs in Microsoft Windows, 98 or NT environment. Network Control Modules provide central monitoring of alarms, and they collect and store data on historical

trends, equipment runtime and energy consumption. Plus, M-Web lets you monitor systems and equipment from anywhere in the world via the Internet.

The M5 Workstation combines the best industry standard hardware and software with Johnson Controls 100-plus years of control experience to create an easy-to-learn and use, yet powerful interface to the Metasys Network. With all of these advantages, your decision couldn't be simpler - the M5 Workstation and the integrating Metasys Network are the perfect solution to assist you in managing the needs of your dynamic enterprise.

Contact: Aidan Lynch, Thermo Systems.  
Tel: 01 - 493 1701;  
Fax: 01 - 493 1746;  
email: aidan.lynch@thermosystems.ie



YORK INTERNATIONAL

# Direct from York

Leaders in the field of  
Air Conditioning and Comfort Cooling

Full Equipment Sales, Service, Commissioning,  
Maintenance and Spare Parts

## DUCTABLE AIR HANDLING UNITS



Split System - 19kW to 70kW

Split (20 to 72kw) Condensing unit (Propeller type fan) or (Centrifugal fan)

- Cooling only
  - axial fans on outdoor units SOC 076 to 240, centrifugal fans on units SCOC 076 to 180;
  - ductable indoor units SIC 076 to 240.
- Heat pump
  - axial fans on outdoor units SOH 076 to 240, centrifugal fans on units SCOH 076 to 240
  - ductable indoor units SIH 076 to 240
- Two independent refrigeration circuits from size 150 upwards
- Thermostat supplied as standard equipment



## ROOFTOP PACKAGED AIR COOLED ROOFTOP UNITS



27kW to 94kW

- Cooling only : D2IC 90 to 300
- Heat pump: B2IH 90 to 300
- Gas heating: D2IG 90 to 300
- 2 stage gas burners (or 4 an option)
- 2 independent refrigeration circuits
- 3 independent refrigeration circuits on size 300 cooling only

## EDPAC®



Close control modular range

For further information contact:



YORK INTERNATIONAL

Unit 2004/3 Citywest Business Campus,  
Naas Road, Dublin 12.

Tel: 01 - 466 0177; Fax: 01 - 466 0198.

CORK: Tel: 021 - 346580; Fax: 021 - 346586

# Mostra Convegno Expocomfort

From 21 to 25 March 2000 Mostra Convegno Expocomfort MCE returns to Fiera Milano with a record show, worthy of the new millennium and its history of success. Direct Italian and foreign exhibitors have passed the 1,800 mark and they will be representing about 3,000 companies and occupying 130,000 sq m (about 10% more than in 1998).

The biennial show is one of the most important ones to be hosted by Fiera Milano and it is a must for everybody involved in the international heating, air conditioning/refrigeration, plumbing technology and water treatment, bathroom fittings, pumps and valves industries.

Over the last four shows the total number of direct exhibitors has increased by 30%, and there has been a 127% rise in foreign companies. In addition to the direct exhibitors, another 900 or so international companies take part through Italian subsidiaries or agents.

The 32nd Mostra convegno Expocomfort, organised by Fiera Milano International, a joint venture between Fiera Milano and the multi-national Miller Freeman group, will once again display the most comprehensive array of products, solutions and technologies for domestic and industrial heating and plumbing. It will also offer a comprehensive programme of associated special events and meetings designed to further the industry and technical knowledge of all those involved in the sectors represented.

Servitis, the show of services for the HVAC and sanitary installations sector, will be held at the same time as Mostra Convegno Expocomfort and will be housed in Hall 25. It will cover applications, management and design software, corporate consulting, franchising, trade and multi-media publishing, certification and professional training.

The show is divided into five major product sectors, which are colour-coded in order to help visitors find

their way around such a vast exhibition area.

□ **Heating, Automatic Controls and Co-Generation (red):** This is the largest area and its 525 exhibitors occupy over 44,000 sq m. Once again, many of the exhibitors have booked very large and strikingly-designed stands ... in some cases entire halls.

The major new feature of this sector is the launch of the Co-generation area and a greater focus on alternative sources of energy such as solar. These innovative sectors are increasingly important in the production of energy and, always alert to new technologies, Mostra Convegno Expocomfort provides a

round they will occupy the modern Portello Halls 15 and 16, and there will be some 410 exhibitors.

□ **Pumps, Valves, Pipe Fittings, Heating Accessories (yellow):**

These occupy 16,000 sq m and are represented by 270 exhibitors.

□ **Implements, Tools, Fastening Systems (ochre):** This sector occupies a single hall that extends over almost 3,000 sq m, housing 55 exhibitors.

## Conference programme

Alongside the exhibition, a packaged conference programme has been designed to keep professionals abreast of developments and to focus on technical questions and standards.

The show has always been active in the dissemination of technical developments and MCE 2000 will be no exception. Currently 15 conferences have been organised by the leading trade and industry associations. The conferences, which will run from 22nd to 25th March, will provide valuable opportunities for gathering information, discussion and an exchange of experiences between the experts from the associations that are involved and the trade.

A completely new initiative has been developed for building planners. Personalised product trails will be organised by MCE in partnership with the publisher BE-MA, along with an international conference and a day of technical seminars.

## Special events

Mostra Convegno Expocomfort 2000 will focus on the bathroom. Not only will there be the Padiglioni dell'Arredobagno - The Bathroom Fittings Halls, there will also be three special events: Water Lines: six designs for the bathroom of the future; the Comfort & Design prize: from Standards to Form; and the Wonderful World: Designing for comfort initiative.

Contact: Mostra convegno Expocomfort, Fax: 0039 0248005450; [www.fmi.it/mce](http://www.fmi.it/mce) email: [mce@planet.ie](mailto:mce@planet.ie) ■



unique opportunity to learn about the latest technical, systems and commercial developments in these fields.

□ **Plumbing Technology, Water Treatment and Bathroom Fittings (green):** These closely-

linked areas cover both the technical aspects of plumbing and water treatment, and the aesthetic side and bathroom design. The area focusing on design has been entitled Padiglioni dell'Arredobagno - The Bathroom Fittings Hall - and it is one of the major new features of MCE 2000. Together, these sectors occupy 36,000 sq m and there will be 540 exhibiting companies.

□ **Air-Conditioning, Refrigeration, Ventilation**

**(blue):** This extends over more than 31,000 sq m and its sectors are continuously developing. This time

# Making Sustainable Energy Pay

The Energy Show — the well-established showcase for energy efficiency products and services — has widened its scope for this year to include renewable technologies, several of which are now commercially viable. The Energy Show 2000 will take place in the RDS Industries Hall on 17 & 18 May, 2000 and will include a dedicated Renewable Energy Area beside the Irish Energy Centre stand and immediately opposite the entrance to the seminars.

The new millennium heralds a time of dramatic change for energy users and producers in Ireland. The opening of the electricity market offers new choices, new opportunities and new threats, while the Government's Green Paper on Sustainable Energy signals the national strategies to meet our Kyoto Protocol greenhouse gas statement commitments.

Energy efficiency and renewable sources of energy are essential partners in this objective — efficiency reduces our demand for energy; renewables increase the sustainability of our energy supply.

### Exhibitors

Among those exhibitors already confirmed for The Energy Show 2000 are Albar Associates; Atlas Copco Ireland; Casey Consulting; CODEMA; Cummins Power Generation; Cylon Controls; Dalkia Technology; Danfoss Ireland; Dunlop Design Engineering; Edina Power Plant; EFT Control Systems; Eirtricity;

Electric Drives; EPH Controls; ERDA; ESB; Hanley Air Systems; Honeywell Control Systems; Irish Energy Centre; Irish Energy Management; KB Combustion;

Services; and Woodleigh.

### Exhibition Contact

Margaret Andreucetti, Business Exhibitions. Tel: 01 - 2957418; Fax: 01 - 295 7417. Email: energy show 2000@irish-energy.ie

### Workshops

Over the duration of the Energy Show 2000 there will be a number of Workshops on different aspects of renewable energy and energy efficiency. These Workshops will introduce the delegates to the subject technologies and their applications. Current subject areas planned are:

- Monitoring & Targetting
- Combined Heat & Power (CHP)
- Refrigeration
- Wind Energy
- Renewable Energy in Buildings
- Renewable Energy in Ireland
- Boilers
- Energy Management in Industry and Commerce

The Energy Show 2000 is a must for anyone with responsibility for, or an interest in, energy and energy-related matters, including energy suppliers, energy managers, building design, development and management, and large heat users.

### Workshop Contact

Irish Energy Centre. Tel: 01 - 836 9080; Fax: 01 - 837 2847. Email: Infor@irish-energy.ie ■

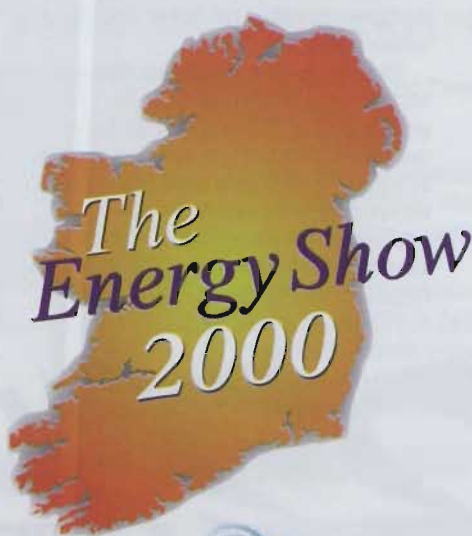

IRISH ENERGY CENTRE

**Efficiency reduces our demand for energy; renewables increase the sustainability of our energy supply**

Keston Heating Products; McCool Controls Engineering; Measureit Technology; Mitsui Babcock Energy Services; NEG Micon UK; Northern Ireland Electricity; Powerlogic; Prolux; Safegard Systems; Sauter HVAC Controls; Scan Energy & Environmental Services; Schneider Electric Ireland; Spirax Sarco; Tech Con Sales; Telemecanique; Viterra Energy



**FACT FILE**

# RAS-C Bi-Directional Domestic Radiator Thermostats

*"Affordable Quality"*

**High Performance liquid sensor**  
Provides superior performance compared to similarly priced wax sensor products

**Reliable non-stick gland seal**  
Provides years of trouble free service

**Installer Friendly Tail-Piece**  
Ridged thread grips PTFE tape, sliding olive provides up to 8mm of length adjustment.

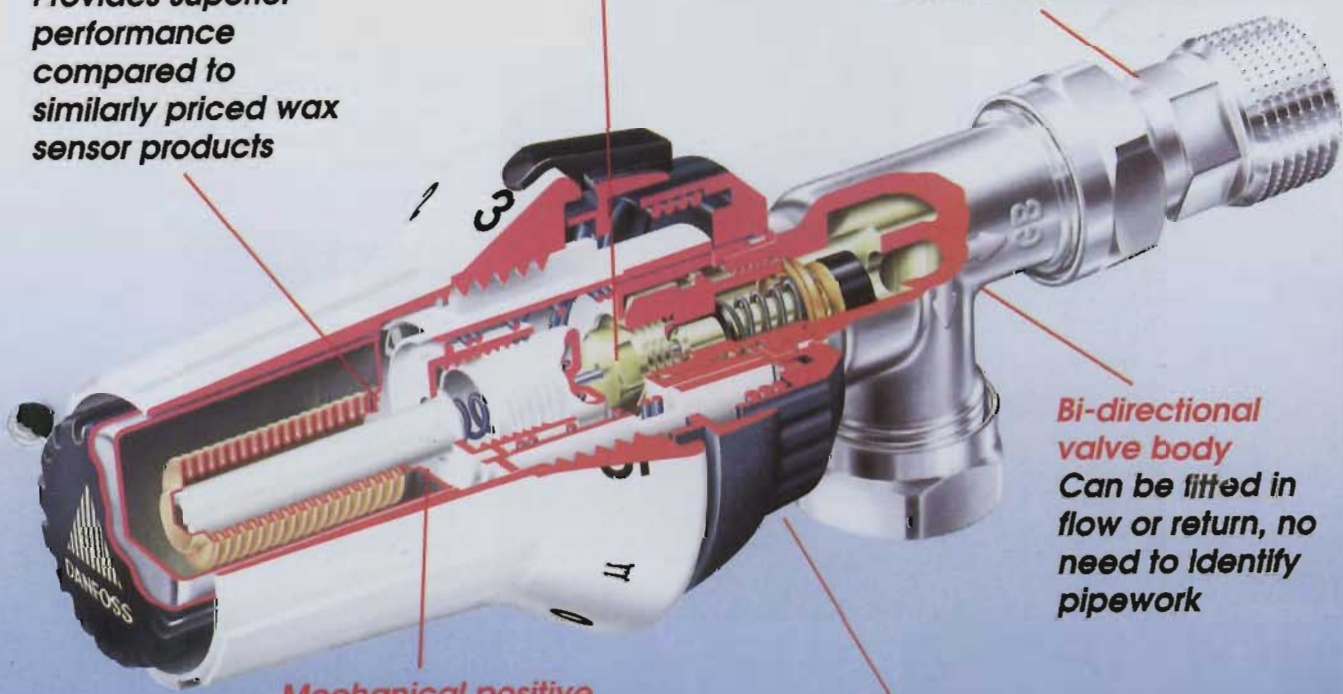

**Mechanical positive off feature**  
Allows radiator to be removed without risk of leakage, whatever the temperature

**Unique snap-lock sensor fitting**  
Quick and easy to fit, requires no tools

**Bi-directional valve body**  
Can be fitted in flow or return, no need to identify pipework



**Danfoss (Ireland) Ltd.**

Nangor Road Business Park,  
Dublin 12, Ireland.  
Tel: 01 - 626 8111; Fax: 01 - 626 9334  
email: sampson@indigo.ie

ENERGY NEWS

# Energy Efficient Motors – £45 Million Annual Saving

An audience containing representatives of some of Ireland's leading companies, including Intel, Tara Mines, Aer Rianta and Schering Plough, heard how they could save up to £45 million pounds annually on energy use by the utilisation of energy-efficient motors. This would represent a reduction of over 630,000 tonnes of Irish carbon dioxide emissions, which is the main global warming gas.

These figures were outlined by Andrew Parish, Marketing Executive (Technical) at the Irish Energy Centre, in his opening remarks to a recent Irish Energy Centre Workshop held at the boyne Valley Hotel, Drogheda, Co Louth.

According to Mr Parish, "Electric motive power systems can be found, predominantly in fans and pumps, but also in conveyors, compressors and processes throughout industry, and have a significant impact on business and the environment with over 25% of the total EU electricity consumption taken up by motors".

To put some figures on this, 25% equals approximately 500,000 GWh at a cost of nearly 30 billion Euros!! In environmental terms, this equates to approximately 385 million tonnes of CO<sup>2</sup> released into the environment from power generation plants.

Given this scale then, even small improvements can have significant



**Virgil Bolger, Irish Energy Centre.**  
Tel: 01 - 836 9080.

financial and environmental impacts.

It has been estimated that savings of up to 15% are achievable in this area resulting in possible savings of 4.5 billion Euros and an annual reduction of 58 million tonnes CO<sup>2</sup>. In industry, motors contribute up to 80% of total

electricity consumed and in Ireland equates to nearly 5,500GWh with an annual spend of nearly IRE300 million.

A 15% motor power saving in Ireland would reduce our CO<sup>2</sup> emissions by 635,000 tonnes per annum, or 9% of our national target!

So, the Irish Energy Centre – in line with its mission to promote a sustainable national energy economy – is obviously supporting and encouraging the use of energy-efficient technologies and techniques in the motive power area in order to ensure that all possible savings are achieved.

The first speaker of the day was Dave Reynolds of ESB who outlined energy saving opportunities in motive power. Dr Hugh Falkner of ETSU, UK, followed Dave and described some of the recent technology developments in this area. He went on to explain the new European motor classification system which is similar to the domestic appliance energy labelling that categorises equipment according to their energy efficiency. Gerard Lambert of Leo Laboratories, Dublin, gave an example of how using energy-efficient motors saved money in a recent project on site.

The workshop finished with a presentation from Gerry Teeling, Plant Manager at Premier Periclase, who showed how they are making savings of over £1 million per annum by adopting energy savings practices and techniques. The audience was then treated to a fascinating tour of the Premier Periclase factory, which contains some of the largest motors in the country.

The workshop and site tour was organised under the Irish Energy Centre's "Self Audit Scheme" with the objective of providing a practical update on methods to reduce energy costs through applying best practice.

The Centre's "Self Audit Scheme" is a voluntary initiative in which member companies commit themselves to regular energy audits of their energy consumption, the setting of annual energy saving targets and the publication of an annual statement of their achievements. In return, companies are assisted in identifying, implementing and monitoring their energy saving projects. ■



Pictured at the site tour of the Premier Periclase plant were: Barry Mellerick, Outokumpo (formerly Tara Mines); Stephen Sisk, Schering Plough (Brinny) Company; Martin O'Connor, Aer Rianta; Hugh Falconer, ETSU (Energy Technical Supports Units); Andrew Parish, Irish Energy Centre; Brian Sheridan, Irish Energy Centre; Aidan Barbar, Wellman International Ltd; John Kelly, Jannssen Pharmaceuticals Ltd; Bryan Evans, Intel Ireland Ltd; and Emma Greene, Carbery Milk Products Ltd



# unitron

experience

# tomorrow's

control

# today

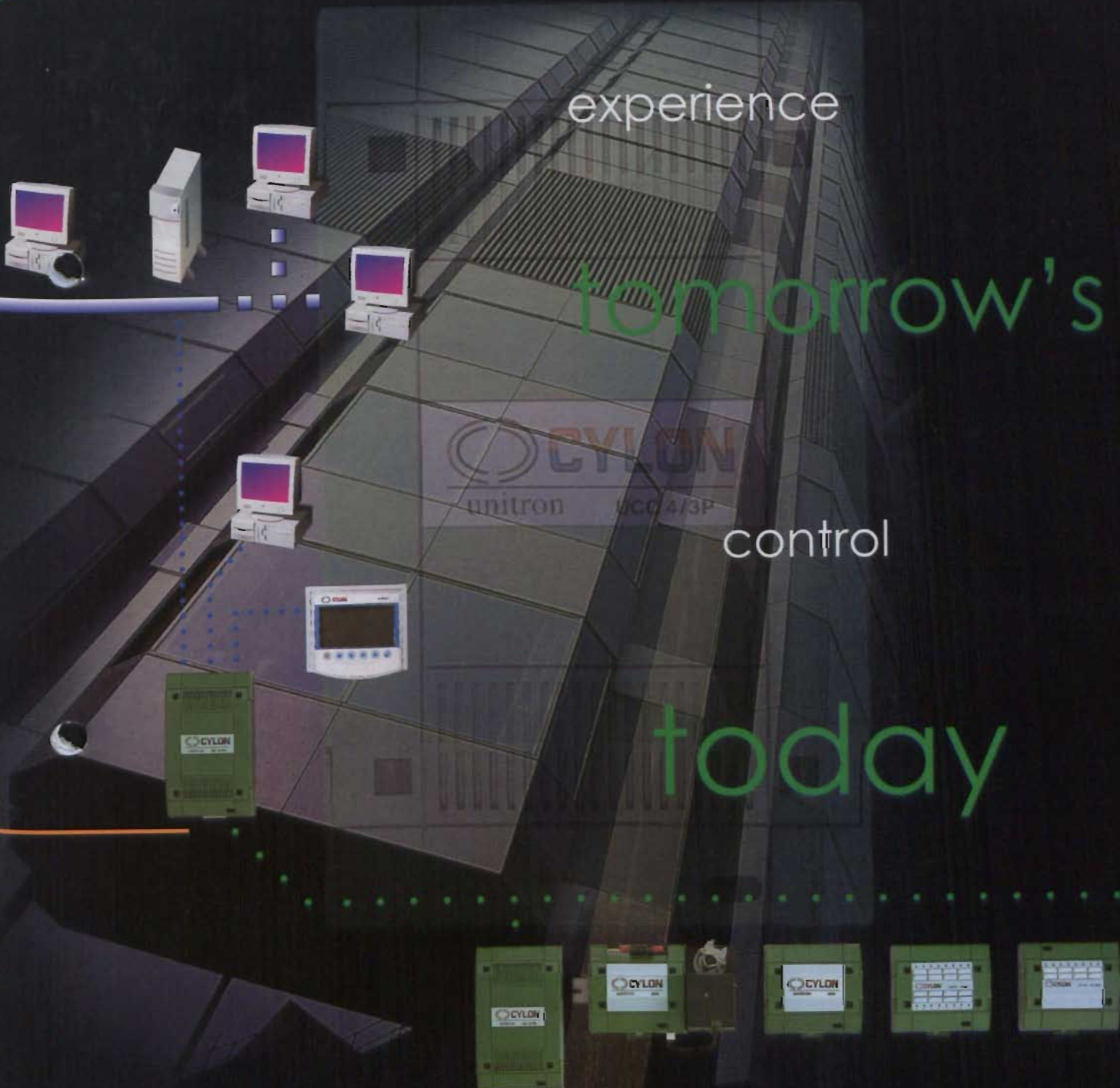

With a controls range spanning 8 to 24 points, a flexible three layer network, and a choice of display interfaces, unitron's modular expandable design delivers outstanding control solutions on projects of all sizes. For a brochure or further information please contact Cylon today on 01 8366626.



NEW TO THE MARKET

## Danfoss Introduce ECL Comfort

**D**anfoss Ireland has introduced a new generation of weather compensators called ECL Comfort for the control of heating systems. The ECL Comfort product range – which replaces the present LCL/CPU range – consists of three series of regulators, each covering different requirements.

– ECL Comfort 100 is a regulator for the control of one heating circuit. Operation is built up around an optional analogue on/off clock and simple analogue settings. The regulator fulfils the basic requirements for controlling a heating system with one circuit.

– ECL 200 is also a regulator for the control of a heating circuit but, in contrast to the ECL Comfort 100, the ECL Comfort 200 provides possibilities of individual adaptation to the actual heating system, i.e., more parameters can be set.

– ECL 300 is a regulator for larger systems and contains two regulating circuits.

A typical application would be where one circuit controls the heating side while the other is used for service hot water control. ECL Comfort 300 can of course also be used to control two heating circuits.

A new room panel and a remote operation module are also available with the new ECL Comfort products.

Ease of operation, application adaptation and flexibility have been given very high priority in the development of ECL Comfort.

### Ease of operation

Operational friendliness is a relatively wide term but in the Danfoss Building Controls Division it is understood as meaning every point at which the customer comes into contact with the product, i.e., the product itself, the associated documentation and, in some cases, the after sales service.

When control requirements for a heating system have been determined, it must be easy to select the components necessary to ensure the system is optimum.

In addition, the installation and commissioning of units must be easy

and straightforward, without problems.

As far as the end user is concerned, e.g., caretaker, boiler minders or ordinary users, it is important that the settings for daily operation be easily accessible. Therefore, a new and more user-friendly documentation concept has been developed for ECL Comfort:

- Brief daily operating instructions have been printed on ECI Cards.
- A Quick Guide containing more extensive daily operating instructions has been compiled and is located in the lid of the regulator;
- More comprehensive forms of installation and operating instructions are accompanied by an easy-to-read and unambiguous guide.

### Application matching via ECL Cards

ECL Comfort 200 and 300 each cover a number of applications. An ECL Card has been made up for both units, and for each application.



EDL Comfort 200 from Danfoss Ireland.

With ECL Comfort 200 the applications are pre-programmed and application selection must be made via the ECL Card and regulation keys on the regulator.

ECL Comfort 300 covers a greater number of, and more complex, applications. Therefore it must be programmed with an intelligent ECL Card, i.e., a card in which a chip contains the information necessary for configuring a given system.

The card provides, for example, regulator parameter pre-settings and programme sequence determination.

System parameters often depend on the given application and the country

in which the regulator is installed. Thus the content of individual ECL Cards can be adapted to specific needs.

In addition, ECL Cards greatly simplify regulator installation in that the number of necessary parameter applications is significantly limited.

### Daily operation

An ECL Card is very useful on a day-to-day basis. The integrated relationship between the text on the card, the display, and the push-buttons makes up a complete and clear operating interface.

### Communication

ECL Comfort products also give the possibility of communication at different levels.

ECL Comfort 300 has, as standard, an RS 232 communication port. With ECL Comfort 200 this is optional, depending on whether a built-in RS 232 port is required (the design facilitates the building in of the port). Common to both ECL Comfort 200 and 300 is the possibility of communication with other units through standard protocols. Since 1999, communication via LON protocol has been offered. Other standard protocols such as EIB and M-BUS are also on offer.

### Product with future

The flexibility of ECL Comfort products is also an important factor. Flexible ECL Cards and the possibility of extending the regulator with different option cards (e.g. communication, analogue input/output and extra relays) ensure quick and easy adaptation to new applications.

The customer, therefore, knows that the regulator will precisely cover his present requirements, and also that with the extension and communication facilities the regulator offers, it will cover his future requirements too.

It is thus possible to buy only what is necessary now without sacrificing the opportunity of extending or making adaptations later in order to follow new developments.

Contact: Ole Thygesen,  
Danfoss Ireland.  
Tel: 01 - 626 8111; Fax: 01 - 676 9334.  
email: sampson@indigo.ie ■



# MASTER AIR

**Manufacturers & Suppliers of Air Conditioning Equipment**

- Air Handling Units**
- Packaged Boilerhouses**
- BMS Control Systems**
- Control Panels**
- Chillers**
- Condensing Units**
- Humidifiers**
- Dehumidifiers**
- Grilles**



**Masterair, John F Kennedy Park, Killeen Road, Dublin 12.  
Tel: 01 - 460 2188; Fax: 01 - 460 2193; email: masterair@tinet.ie**



- ◆ Fan Coil Units
- ◆ Packaged Water Chillers
- ◆ Heat Pumps
- ◆ Roof Top Units
- ◆ Close Control Telecom Units

CIAT are a well-established international company, who are not only a main supplier to the European Air Conditioning market, but are also world leaders in Refrigeration, Air Conditioning and Heat Transfer equipment, with subsidiaries and agents in over 50 countries.

At their headquarters, the extensive Research & Development Laboratories, Drawing Offices, Manufacturing and Testing Facilities are all staffed by experienced and professional personnel using the latest automated systems, thereby ensuring a rapid and continuing expansion.

CIAT are committed to design innovation, manufacturing excellence and above all to providing their customers with quality air conditioning equipment to meet their needs.

### LGN PACKAGED CHILLER

17 — 180kW  
Small Foot Print  
Extremely Low Noise Levels



### COMPACT UTA FCU

Fan Coil Units complete with Inlet/Outlet plenums with F/A  
Low Noise High Static Pressure  
Factory Fitted Control Options



### LDH PACKAGED CHILLER WITH PUMPS

Complete Chiller/Pumps Package  
Self contained with all controls  
25 — 170kW  
R134A & R407c Refrigerant Options



### LW WATER COOLED CHILLER

160 — 500 kW  
Fitted with Screw Compressors & PRSI microprocessor control  
Low Noise Acoustic Housing  
R134A & R407c Refrigerant Options





Large, 3D, gold-colored letters spelling "SIPS". The letters are thick and have a metallic sheen. A red circle is positioned on the top of the letter "I". The background is a light blue gradient with faint, scattered Roman numerals and architectural columns.

Some companies change with the **new Millennium**  
We've changed **more** than just our name

# A New Era Trusted service

**SiBS**

From the 1st March 2000 Duct Cleaning Services will operate under the new name SIBS - **S**pecialist **I**ndependent **B**uilding **S**ervices. Entering the new millennium, our expanding range of specialist services has outgrown our original name. SIBS has been chosen to represent the full range of our services and to mark the start of a new era for the company.



We are Ireland's longest established Indoor Air Quality (IAQ) service provider and our impressive client list includes numerous high-tech multinational manufacturing facilities. Over the past decade SIBS has developed advanced techniques to maximise the operating efficiency of HVAC and process air systems to satisfy our clients increasing quality and safety requirements.

## OWNERSHIP

In December 1999 directors Martin Deevy and Brian Noone gained 100% ownership of the company following a management buyout of investors. This affords us the opportunity to independently develop the quality and range of services to meet our clients evolving needs.

Both Directors have complimented their Engineering Qualifications with Certification by NADCA, the U.S. based international professional body that tightly regulates industry standards. NADCA's stringent Air System Cleaning Specialist certification is a important achievement and an assurance of our comprehensive industry knowledge and experience.



### **Martin Deevy - Director.**

Director of the company since start-up, Martin has 15 years' experience in H.V.A.C. and process system installation, commissioning, validation and hygiene maintenance.

As a founder member of the first dedicated Indoor Air Quality (IAQ) company in Ireland, Martin has been responsible for setting the high standards within the industry.



### **Brian Noone - Director.**

Brian joined the company in 1996, bringing with him extensive validation and commissioning experience in high-tech manufacturing facilities.

He is the driving force behind the efficient organisation of our technical staff and our excellent customer relations.

## ADVANCED SPECIALIST SERVICES

Building owners are under increased pressure to provide acceptable levels of Indoor Air Quality (IAQ), Air Change Rates and Fresh Air Quantities in order to achieve acceptable environmental standards in occupied areas. We offer a comprehensive range of services to provide a cleaner, healthier and safer environment for all building occupants to enjoy.

### **SIBS provides the following specialist services:**

#### **Ventilation Hygiene Services -**

CCTV surveys, Risk Assessment and IAQ Audits as well as Air Duct Cleaning using advanced equipment and techniques. We specialise in the decontamination of process facilities, dust extractors and the removal of chemically contaminated ducts.

#### **Commissioning and Validation Services -**

Fan and pump performance testing, proportional balancing of air and water distribution systems, room-to-room differential pressure set-up, commissioning management, and independent witnessing services, with comprehensive reporting.

#### **H.V.A.C. & Building Maintenance Services -**

Ranging from short term fixed price contracts to long term placement of engineering and trade staff in large facilities.

## STEPPING INTO THE FUTURE

We are committed to improving the quality of service we provide on an ongoing basis. We aim to achieve this by using state of the art equipment / techniques along with the implementation of improved quality control procedures and staff training programmes.

Indoor air Quality is a key health, environmental and legal issue. Let us help you take a proactive approach to supplying cleaner air to your building which in turn promotes a healthier working environment and improved all round efficiency.

The logo for SIBS (Specialist Independent Building Services) features the letters 'SIBS' in a bold, orange, sans-serif font. The letter 'I' is smaller and positioned between the 'S' and 'B'. The 'S' and 'B' are larger and more prominent.

**SPECIALIST INDEPENDENT  
BUILDING SERVICES**

Unit 1, Naas Road Business Park,  
Muirfield Drive, Naas Road, Dublin 12

Telephone: 460 0740

Facsimile: 460 0720

e-mail: [info@sibs.ie](mailto:info@sibs.ie)

Web: [www.sibs.ie](http://www.sibs.ie)

# EXPERIENCE THE FULL BENEFITS OF THE 'TOTAL PACKAGE' FROM MASTERAIR

of all BS News



Michael Lynch, C.Eng., M.C.I.B.S.E., Marketing Director and John McCarthy, Director and General Manager

**M**asterair is one of Ireland's leading manufacturers and suppliers of air conditioning equipment, providing customers with a comprehensive range of market-leading, quality products, supported by the highest standards of technical and service excellence.

Masterair's goal is to exceed customers expectations with professionally-competent teamwork, and a clear focus on providing added-value solutions.

In air conditioning systems there are three major considerations — capital, energy and maintenance. Hence Masterair's portfolio is designed to give the end-user an economical, energy-efficient, and well-manufactured air conditioning system which, while being cost-effective to install and run, does not compromise on quality or performance.

Masterair offers the total package, providing clients with a complete range of air handling units, grilles, humidifiers, dehumidifiers, chillers, condensing units, motor control centres and automatic control systems, including building management systems. Complementing that is the full spectrum of commissioning and after-sales technical support services, including tailored maintenance management contracts.



Jim Lynch, Commissioning Manager

Given the complexity of modern-day air conditioning solutions and considering the importance of ensuring trouble-free on-site co-operation between all the parties involved in each project, Masterair has devised a complete range of pre-piped and pre-wired packaged "plug-in" units. There is also a range of fully pre-packaged boiler houses.

All units arrive on site complete with motors, pumps, boilers, frequency converters, and valves pre-piped and factory commissioned. The installation savings are self-evident, not to mention the added bonus of the many associated benefits.

Masterair has a pedigree stretching back over two decades, over which time it has firmly established itself as one of Ireland's premier solutions providers in respect of air conditioning and ventilation. It does so by a mix of own-manufactured units and a range of world-renowned, market-leading brands such as Munters, CIAT, TAC, Schako, Hoval, Cylon, etc.

The manufactured equipment is produced at Masterair's 4,400 sq m manufacturing plant in Dublin under strict quality control procedures in accordance with the requirements of BS EN ISO/IS EN ISO 9002 to which it has full accreditation.

Computer aided design and drafting facilities, together with in-house acoustic analysis and component selection programmes, enable a fast and detailed response to all customer enquiries. Every situation is unique and Masterair works closely with all relevant parties, including the consultant and contractor, to devise the most appropriate, cost-effective and best-performing solution.

Masterair currently employs 75 people, all of whom are highly-qualified and fully-trained in all aspects of their respective areas of responsibility. The company's continuous policy of training further strengthens and reinforces Masterair's ability to deliver on the ideal of the "total package" concept.

With your requirement for air handling units, packaged boilerhouses, building management control systems, control panels, chillers, condensing units, dehumidifiers, humidifiers or grilles, Masterair has the solution.



Patrick O'Leary and Gwen Boud, Technical Sales Engineers

Experience the full benefits of the "total package" concept ... talk to Masterair.



# One thing is certain - CHANGE

The prestigious office buildings you are developing today may in a few years time require new internal layout or more extensive conversion. As your business develops, your building and services requirements will change. Your open plan office may need converting into a restaurant or training area in the future. Therefore a flexible, future proof building automation solution should be considered.

## How far will bespoke solutions STRETCH?

Bespoke Building Automation Systems will certainly fulfil most environmental & security requirements, but how will they deal with the future?

It may be an expensive dead end when the need to expand or change the activities of the building becomes a reality!

TAC allows you complete freedom to co-ordinate the benefits of our Building Automation Systems with other building services such as fire, security, access control & lighting control.

TAC uses the strengths of an open network solution based on LonWorks®. This technology provides you with complete freedom to add or change the system now or in the future. In addition, as this common network is also utilized by many other manufacturers of fire, security, access control & lighting control systems, your decision to use TAC becomes even more obvious.

*TAC - By the time the future arrives,  
we will already be there!*



Our thoughts on the Open Building and LonWorks® have been collected in a book. Read it if you're planning to build, renovate or rebuild. Whether you're the owner, user, architect or consultant, or just curious as to how an open system provides unlimited possibilities - today and in the future. Order the book from Masterair, John F Kennedy Park, Killeen Road, Dublin 12. Tel: 01 - 460 2188; Fax: 1 - 460 2193; email: masterair@tinet.ie

LonWorks® is a registered trademark from Echelon Corp.

www.tac.se



## Schako AC Components

Schako was founded in 1928 by Mr Ferdinand Schad in Kolbingen, a small village located in the south of Germany between the international airports of Stuttgart and Zürich in Switzerland.

Today Schako is still a family-owned company and has developed steadily over the years, apart from the factory in Kolbingen, it has further production facilities in the German town Messkirch (approximately 35 km away from Kolbingen), and the Spanish town San Mateo, in the suburbs of Zaragoza. In total the company now employs 400 people.

In the late 1980s the company expanded its sales network to embrace all of Europe. Today it holds own sales branches, or is represented by independent companies, such as Masterair in Ireland.

The range is extensive and comprises the full spectrum of air conditioning components, such as:- ventilation grilles; twist diffusers; ceiling diffusers; long range nozzles; slot diffusers; floor diffusers; step diffusers; fire dampers; flow regulators (mechanical, electric, pneumatic); air dampers; silencers; and filter boxes with Hepa filters.

Its own laboratory for new developments and testing guarantees that products are of the highest technical level.

Sound advice, design support and a PC selection programme for all products is available to support all customers.

**Use our Know-How to your advantage.**



**Final commissioning check on packaged boiler house prior to client hand-over**



## Munters – The Humidity Experts

Munters is a worldwide market-leading brand name providing products and services for humidity control in industrial, commercial, residential and agricultural applications. Munters dominates the humidity control business with a global market share of between 50% and 70% within these sectors.

The technology of the core products involves the interchange of air and water. The operations are focused on four niche areas – Dehumidification (DH); Moisture Control Services (MCS); HumiCool (Evaporative Cooling/Humidification); and Mist Elimination/Water treatment. Applications cover a wide range of industrial and commercial situations, including pharmaceutical, electronics and chemical processing facilities.

The marketing activities of Munters is organised on a regional basis into three geographic operating regions, each with distinct market and climate conditions. These are Europe, The Americas and Asia. Munters maintains its own sales organisation with technical and after-sales support within each of the three regions. Masterair is the representative in Ireland.

The company is established in 25 countries all over the world and Most of the companies are certified according to ISO 9000.

## TAC Control Solutions for Building Services Systems

TAC develops, manufactures and markets system solutions, products and software for the control and supervision of building services systems via open integrated systems intended for use by customers looking for optimum indoor comfort, safety and operating costs.

TAC has approximately 1000 employees, with subsidiary companies in the Nordic countries, the UK, Germany, Poland, Russia and Singapore.

Additionally, this network is complemented by trading partners in over 40 countries such as Masterair in Ireland.

The products include include high quality, fully-programmable controllers, sensors, actuators, and control valves.

TAC are among the world market leaders in automatic control systems for the HVAC industry.



Quality control inspector examining a frameless air conditioning unit as it comes off Masterair's manufacturing line

# THE HUMIDITY EXPERT



Munters is a global provider of products and services in the highly specialised humidity control market. Our product range includes a large selection of desiccant dehumidifiers from large modular dehumidification systems down to small portable units.

Munters is the leader in the design and production of desiccant wheel based dehumidification systems for commercial and industrial applications. Experts in humidity, "the invisible water which exists in the air around us", Munters provides protection for products and equipment against the permanent damages excess moisture causes.

Units distributed on behalf of **Munters Ltd**

 **by Masterair**  
John F Kennedy Park  
Killeen Road, Dublin 12

Tel: +353 14602188  
Fax: +353 14602193



# Munters

## CIAT – Air Conditioning & Refrigeration

CIAT is one of Europe's leading manufacturers of air conditioning and refrigeration equipment for commercial and industrial use. Established in France in 1934, it currently has subsidiary companies in the UK, Belgium, Germany, Switzerland and Spain. The company has a network of representatives and distributors throughout the world, Masterair being its representative in Ireland.

As the leading supplier of air conditioning and air treatment equipment on the European market, CIAT has devised a number of unique solutions for some very high-profile applications. For instance, it was selected by the Egyptian Antiquities Department for the ventilation of Cheops' pyramid, one of the seven wonders of the world.

The daily flow of tourists, saturating the atmosphere inside the Great Pyramid with humidity and carbon dioxide, represents a threat to the preservation of the prestigious monument. CIAT proposed and installed a solution which was approved by the Supreme Council of Antiquities. The installation is now operational and ensures that the monument is preserved perfectly.

The CIAT product portfolio is wide-ranging and diverse, catering for virtually every conceivable air conditioning and ventilation application. It includes:-

**Air conditioning units** – packaged air conditioning units; telecommunication room cooling; computer room units; and fan coil units.

**Refrigeration units** – packaged air cooled/water cooled chillers complete with buffer tank, pumps, and all associated pipework; air/water cooled condensers; condensing units; heat pumps; and roof top units;

**Heat exchangers** – shell and tube heat exchangers; plate heat exchangers; and dry coolers.



Packaged boilerhouse being pre-piped and pre-wired with TAC controls

## Hoval Industrial Ventilation

Hoval is a world-recognised name and one of the acknowledged market leaders in industrial ventilation. Renowned as innovative and pioneering, Hoval continues to bring technological breakthroughs to the marketplace which become standard industry norms.

Ventilation systems are subject to different regulations for industrial applications compared to conventional air conditioning. This fact was taken into consideration when the Hoval industrial ventilation system was developed. Its particular characteristics are the decentralised arrangement of the units and air injection from above without extra ducting.

Special features and advantages are:

- ideal for mounting heights between 3m and 13m;
- no temperature stratification in the room – low fabric heat loss;
- evenly distributed draught-free ventilation;
- flexibility of the decentralised system for changing working conditions;
- high operating security;
- no supply air and exhaust air ducts;
- space/cost saving through high level installation;
- heat recovery from extract air;
- centralised control;
- distributed in Ireland by Masterair.



WDA



QR



IKA



BK 133



<https://arrow.tudublin.ie/bsn/vol39/iss2/1>

DOI: 10.21427/D7DM7S

PC-AUSLEGUNGSPROGRAMM

## ICHAKO

one of the leading manufacturers of ventilation  
& air conditioning components and

## MASTERAIR

one of Ireland's most established and  
experienced building services engineering  
companies, offer a full range of diffusers,  
fire dampers and silencers.



Its own laboratory for new developments and  
testing guarantees that products are of the  
highest technical level.

Sound advice, design support and a PC selection  
programme for all products is available to  
support all customers.

Use our Know-How to your advantage.

## ICHAKO

Masterair, John F Kennedy Park, Killeen Road, Dublin 12.  
Tel: 01 - 460 2188; Fax: 01 - 460 2193; email: masterair@tinet.ie

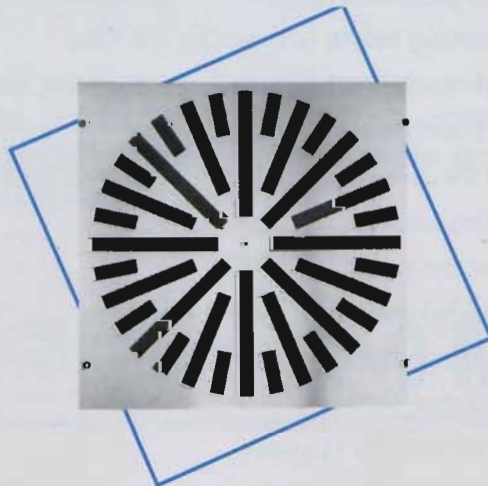

DQJ

# Two Strong Partners



## Thermowatt from Plumb Direct

While still a relatively young company, Plumb Direct has already made significant inroads into the building services supply sector with a range of quality, branded products from some of the world's leading manufacturers.

Supporting this broad-ranging portfolio is the technical expertise of its principal directors — Alan Seery and Kevin Shanahan — both of whom are widely known and have extensive experience of the industry.

Just recently Plumb Direct has added a new name to its growing portfolio, the Thermowatt range of monophase circulating pumps for domestic use in applications involving warm water circulation which is free from abrasive substances.

Key features and benefits of the new range include:—

— Low noise and low

level of vibrations thanks to the perfectly-balanced rotating components;

— Connections can be either thread or flange;

— High initial torque allows for easy starting, even after long periods of rest;

— All immersed components are made of stainless steel, heat-resistant resin or other materials resistant to corrosion.

Another feature of the manufacturing process (which is ISO 9001 certified) is that all Thermowatt circulating pumps are immersed rotor type, in which the shaft and bearings are lubricated by the circulating liquid. The pump body is cast iron; impeller is heat-resistant resin; gap jacket is stainless steel; flange is brass; shaft is made from ceramics; and the bearings are carbon graphite.

Technical data is as follows:—

Motor — Monophase motor: 220,230 and 240 volts; Frequency: 50 or 60 Hz available; Speed: 1 or 3-speed; Isolation Class: F.

Other Features — Waterproof (IP42); Fluid temperature limits: 7 C to 95 C; Working range temperature: 2C to 60C; Max working pressure: 6 bar; Minimum working pressure: 2.5 mca (to avoid corrosion and consequently noise effects).

Contact: Alan Seery or Kevin Shanahan, Plumb Direct. Tel: 01 - 457 9030; Fax: 457 9029.

## Monophase Circulating Pumps for Domestic Use

Warm water circulation, free from any abrasive substances



TA TYPE

- ◆ Pump body: cast iron
- ◆ Impeller: heat resistant resin
- ◆ Gap jacket: stainless steel
- ◆ Flange: brass
- ◆ Shaft: ceramics
- ◆ Bearings: carbon graphite
- ◆ 5MTR or 6MTR Head

Certified Quality System ISO 9001



**Plumb Direct**

Units C2-C3, Station Road  
Business Park, Clondalkin,  
Dublin 22.  
Tel: 01 - 457 9030;  
Fax: 01 - 457 9029



Thermowatt monophase circulating pumps for domestic use from Plumb Direct.



*for all your pumping requirements  
Circulators, Pumps, Boosters ...*



*... just add water!*

White Heather Industrial Estate, 301 South Circular Road, Dublin 8. Tel: 01 - 416 5100; Fax: 01 - 416 5165  
eMail: 1930.sales@bssgroup.com

## BOSS ... Introduction to Pressurisation

Heating and chilled water systems traditionally use an open tank to accommodate expansion within the system in the event of a rise in temperature. This method has several disadvantages which include:-

- water has to be stored at high level;
- air is allowed into the system causing corrosion;

temperatures, allowing smaller pipework and radiators;

- Compact equipment size reduces space requirements;
- Quicker installation;
- Equipment can be sited in the boiler house for ease of maintenance;
- No problems with freezing pipe work and tanks in the roof space.

light commercial applications.

Contact: John Brophy, BSS Ireland (Dublin).  
Tel: 01 - 454 1966;  
Fax: 01 - 454 1017;  
Michael Quinlan, BSS Ireland (Cork).  
Tel: 021 - 321588;  
Fax: 021 - 321595.

Below: BOSS Pressfills are quality-engineered pressurisation units of a robust compact design. Models available include the basic Type AX, the fully-packaged cabinet-housed Type PF, the microprocessor types PFM; and Mini Pressfill compact units. Details from BSS Ireland.



A comprehensive range of portable pumps offering a complete solution for the pumping of clean or dirty water. All models are of robust construction, quiet in operation, reliable and versatile, allowing confident use in fixed or portable applications with automatic float switch operation, if required. Details from BSS Ireland.

- use of high-temperature systems is limited.

These limitations gave rise to the design of the "sealed system" where the expansion of water in the system is accommodated within a sealed vessel, eliminating the need for an expansion tank at high level and providing other benefits, including:

- Virtual elimination of corrosion as no air is allowed into the system under normal operating conditions;
- Higher design

This equipment is designed for use on sealed systems with no draw-off points. If taps, showers, etc are included within the system, a pressure booster set should be used.

For light commercial central heating installations a full pressurisation set would be excessive. If a pressurised system is required, BSS recommends the compact, space-saving, wall-mountable BOSS MX Mini-Pressfill. This performs the same function as larger sets, but is more suited to

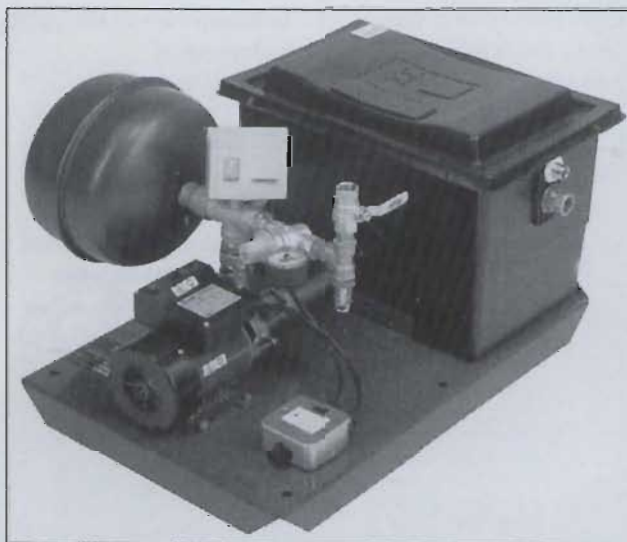

BOSS one-pump booster set from BSS Ireland.



PUMPS AND CIRCULATORS

## Grundfos – The Safe, Reliable, Powerful Choice

Grundfos has been at the forefront in devising pumping solutions for more than 50 years. It has addressed all industry requirements, from the lifting and boosting of groundwater to water

treatment, water distribution and drainage. Throughout these years the Grundfos pump range has been constantly developed to incorporate all the latest technological breakthroughs.

Today Grundfos is recognised globally as one of the pioneering market leaders, with manufacturing plants and subsidiaries in virtually every corner of the world. The Irish branch is a key element of this global network and it plays a leading role in the introduction of new products as they come on stream.

Typical recent examples are the new CHV and CHN ranges.

The CHV pump is a vertical, centrifugal pump, designed for pressure boosting in agricultural, domestic and commercial applications. Due to its vertical design, the CHV pump is a floor-space-saving solution that fits in any pressure boosting installation.

The robust and highly-efficient CHV pump is based on the well-known and reliable CH range.

Since its release the CH range has set the market standard around the world for reliable and powerful multistage pumps.

CHV applications include:-

- Liquid transfer
- Pressure boosting
- Domestic water supply
- Cooling systems
- Air-conditioning systems
- Horticultural irrigation

The pump is fitted with a Grundfos motor, which is a totally enclosed, fan-cooled squirrel-cage motor. Technical details are: Rated speed: 2900 rpm; Enclosure class: IP54; Insulation class: F; Standard voltages: 1 x 220 - 240V; 3 x 220 - 240/380 - 415 V.

The CHN is a horizontal, non-self-priming centrifugal pump with all stainless steel pump parts. The CHN is also based on reliable CH range, and thus has the same dependable and outstanding hydraulic performance. Like the CH, the CHN is designed for a wide range of applications, including boosting of pressure, as well as transfer duties of slightly aggressive liquids.

CHN applications include:-

- Transfer and boosting of domestic water supply
- Irrigation and other horticultural pump duties
- Cooling systems
- Air-conditioning systems
- Washing machines as well as many light-industrial applications, where a compact solution is needed.

The pump is fitted with a Grundfos motor which is a totally enclosed, fan-cooled squirrel-cage motor.

Technical details are: Rated speed: 2900 rpm;

Enclosure class: IP54; Insulation class: F; Standard voltages: 1 x 220 - 240V; 3 x 220 - 240/380 - 415V.

Single-phase motors have a built-in thermal overload protection. Three-phase motors must be connected to an external motor starter according to local regulations.

As for the CH pump itself, this is a horizontal, non-self-priming, centrifugal pump designed for a wide range of applications including the boosting in commercial and domestic water applications as well as ordinary water transfer duties.

The robust and highly-effective CH pump from Grundfos was the first of its kind on the market. Since its release, it has set the market standard around the world for reliable and powerful, horizontal multistage pumps.

All systems in the Grundfos CH range are available as complete water supply systems, including a pressure switch and gauge and all fittings necessary for connection to existing water systems and wells.

The CH range is available in a wide range of sizes, with flows up to 14 m<sup>3</sup>/h and heads up to 93m. The CH pumps can be installed in booster systems with flows up to 16 m<sup>3</sup>/h.

Contact: Gordon Barry, Grundfos Ireland.  
Tel: 01 - 295 4926;  
Fax: 01 - 295 4739;  
email: gbarry@grundfos.com  
Website: www.grundfos.com



Grundfos Ireland plays a leading role in the introduction of new products, such as the recently-launched CHV and CHNN ranges

et al.: BS News

# CHV

- the new standard in vertical pressure boosting pumps

**NEW**



Grundfos (Ireland) Ltd, Unit 34 Stillorgan Industrial Park, Blackrock, Co Dublin.

Tel: 01 - 295 4926; Fax: 01 - 295 4739;

email: gbarry@grundfos.com Website: www.grundfos.com

**GRUNDFOS**



PUMPS AND CIRCULATORS

# Myson Pumps – Number One for Quality and Reliability

**Myson's Compact Range**  
The Myson pumps "Compact" range of domestic heating circulators offers the installer assured reliability, high performance, and ease of installation for all domestic heating systems.

The following are some of the special features of the Myson Compact range:

- It is a 3-speed pump with a static head range of 2-6 metres;
- A safe and sure manual re-start knob frees the pump should it become stuck due to system debris, while providing a secure means of venting it manually;
- Larger terminals with clearly-marked captive screws make connection quick and simple;
- Myson "Compact" pumps are designed to vent automatically on initial start-up, avoiding damage to the shaft and bearings;
- The motor head can be replaced or repositioned without moving the pump from the system;
- The start-up torque on the lower speeds of the range is nearly twice that of competing products in the same class;
- All Myson "Compact"

pumps are guaranteed for 30 months from the date of manufacture, a full year over the industry norm.

**Myson's "SE" Range**  
The Myson "SE" pump range offers a comprehensive selection of pumps as cast iron light commercial circulators or secondary hot water commercial circulators.

The Myson "SE" pump range has a host of special features, including:-

- It is available in 1 1/4", 1 1/2", or 2" as cast iron and from 1" up to 2" in bronze;
- Using disc induction motor technology, these pumps deliver a high ratio torque for effortless low speed start-up;

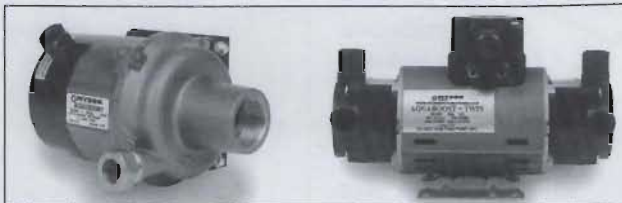

The Myson Aquaboost range of high-performance shower pumps for booster water pressure

- A precision-manufactured double-shrouded impeller provides smooth, flexible output whatever the speed and at temperatures of up to 95°C.

**The Myson Aquaboost Range**

Myson also manufacture a range of high-performance shower pumps for boosted water pressure. The range is as follows:-

**Aquaboost Single** - Suitable for siting between the mixing valve and shower head, these units are supplied with installation kit, comprising factory-fitted flow switch

accessories requiring controllable power, these units are supplied with installation kit including two factory-fitted flow switch controls, pre-wired motor, and as four hose connectors.

With a specialist team of field and in-house technical engineers to take customer queries, Potterton Myson provides expert advice on specification and installation. Full after-sales service and spares are also available and these are complemented by the company's unique training facility which is located at its headquarters on the



The Myson Compact range of variable speed domestic heating circulator pumps.

- The use of a single static "O" ring seal eliminates the need for time-consuming, routine seal maintenance;

control and pre-wired motor;  
**Aquaboost Plus Twin** - Suitable for more complex shower heads and

Belgard Road, Dublin.  
Contact: Potterton Myson (Irl) Ltd.  
Tel: 01 - 459 0870;  
Fax: 01 - 459 0880.

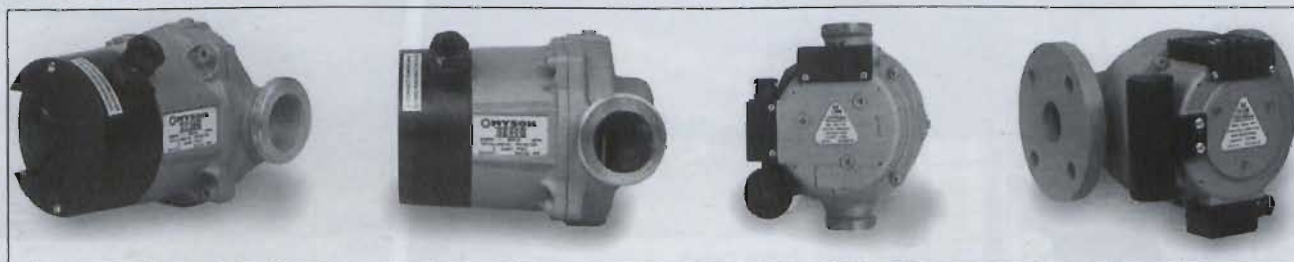

The Myson Bronze range of secondary hot water commercial circulators.

# Number One in Central Heating



PUMPS AND CIRCULATORS

## Euro Fluid – Largest Manufacturer of Packaged Pumping Systems

From humble beginnings in 1990, Euro Fluid has become the largest manufacturer of packaged pumping systems in the country.

The company, operating out of a purpose-built facility in Ballymount, West Dublin, has achieved this distinction by offering total solutions on pumping applications to both the

design engineer and the mechanical contractor.

With a combined total of over 50 years pumping experience coupled with a flexible approach to the manufacturing process, Euro fluid can assist in plant selection through to final supply and commissioning, thus ensuring that the requirements of the most



Eurofluid mains water and cold water duty assist booster set

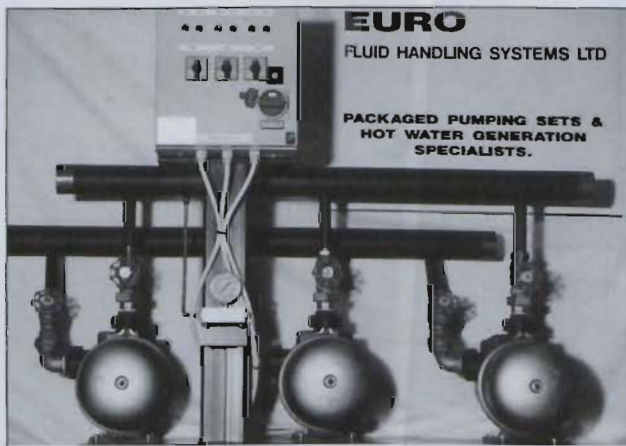

Eurofluid cold water and mains water 3-pump variable speed

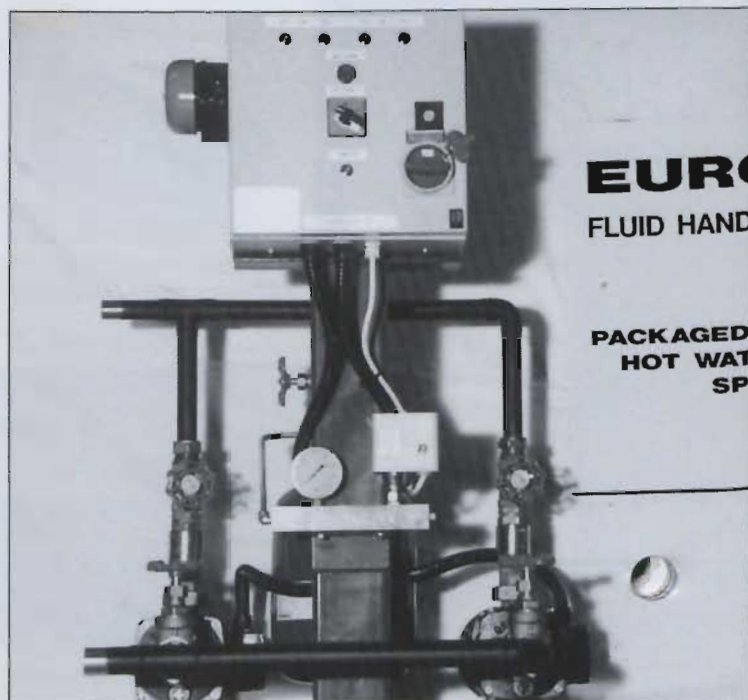

Eurofluid fire hose reel booster

important people, the client, are fully met.

The advances made in pump system design incorporating frequency invertors and plc controllers have been incorporated as standard on the packaged equipment being manufactured by Euro Fluid under the "Europak" name.

The packaged equipment offered by Euro Fluid includes:

- mains water packaged booster sets;
- fire hose reel booster sets;
- oil transfer pumpsets;
- condense recovery sets;
- pressurisation equipment;
- packaged hot water transfer sets;
- packaged steam/water transfer sets.

Prestigious projects Euro Fluid has been involved with include – Citibank; Various CHP Projects; World Com; Schering

Plough; Allergan Pharmaceutical; Wyeth Medica; Norton Pharmaceuticals; Irish Life Boilerhouse Upgrade; Bausch & Lomb; Financial Services Centre; Croke Park Re-Development; The Merrion Hotel.

With the support of major suppliers like Grundfos Pumps (for whom Euro Fluid are a major distributor) Swep Heat Exchangers; ACV hot water generators; Armstrong Pressurisation – and continued investment in modern technology – Euro Fluid will consolidate its dominant position in the marketplace, and continue to supply quality equipment.

Contact: Bernard Costelloe, Euro Fluid Handling Systems.  
Tel: 01 - 460 0352;  
Fax: 01 - 450 7634;  
email: eurofluid@eircom.net

PUMPS AND CIRCULATORS

## Holfeld New Customer Services and Works Centre

Holfeld Pumps has opened a new Customer Services & Works Centre to provide a one-source supply capability for service and repairs at its premises in Merville Road, Stillorgan, Co Dublin.

It incorporates a fully-equipped machine shop, calibrated test facilities, workshops and mobile service units.

The Centre is manned full-time by qualified technical personnel who can provide a quality-assured, on-site, service. In an emergency pumps, spares and components, pipework and controls

from stock — along with skilled staff — can be on site within hours.



Holpak 3-pump variable speed packaged pumpset, as designed and manufactured by Holfeld Pumps. This particular unit is installed in a high-profile international hotel in Dublin.

Contact: Alison Kirwan, HR Holfeld (Hydraulics) Ltd.

Holfeld Pumps design and supply advanced pumping technology from some of the world's leading brand names. It also manufacture the Holpak range of pump sets and pressure booster systems.

Holfeld Pumps are part of the HR Holfeld Group, the diversified engineering product specialists, whose mission is the pursuit of excellence in the world of design, technology, engineering and performance. It has been providing a comprehensive professional service to the industry for over 50 years.

Contact: Richard Burke, Customer Services Manager, Holfeld Pumps.  
Tel: 01 - 288 7361;  
Fax: 01 - 288 7380.

# EURO

## Fluid Handling Systems Ltd MAIN DISTRIBUTOR FOR

**GRUNDFOS**

Pumps



Hot Water Heaters



Armstrong  
Pressurisation Equipment

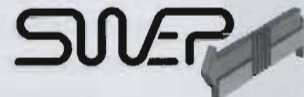

Heat Exchangers

## Manufacturers of Europak

- ◆ Mains Water Packaged Booster Sets
- ◆ Fire Hose Reel Booster Sets
- ◆ Oil Transfer Pumpsets
- ◆ Condense Recovery Sets
- ◆ Pressurisation Equipment
- ◆ Packaged Hot Water Transfer Sets
- ◆ Packaged Steam/Water Transfer Sets

Unit 12, The Westway Centre, Ballymount Avenue, Dublin 12.

Tel: 01 - 450 3884/460 0352/460 0353; Fax: 01 - 450 7634



## Style & Comfort

### *Innovative Design*

The Purmo Compact heralds a new era in radiator design with every single and double panel model coming complete with factory-fitted side panels and top grille as standard. Specially designed to blend unobtrusively into the decor of any home, its neat lines and contours ensure that the Purmo Compact complements any interior.



### *Proven Pedigree*

The compact is the latest in a long line of innovative, trend-setting products from Rettig, one of Europe's longest-established, specialist producers of high performance heat emitters.

### *Quality Guaranteed*

Purmo Compacts are manufactured under a quality system conforming to ISO 9000. Each radiator undergoes the most stringent production, anti-corrosion and finishing treatment to ensure a product of the highest quality and integrity capable of many years trouble-free performance even in the most demanding conditions. The Purmo Compact also carries the British Standards Kitemark, which certifies quoted heat outputs to BS EN 442 and guarantees performance.



### *Performance Excellence*

The Purmo Compact's sleek design and modest dimensions embrace a water envelope which demands remarkable low water content to provide controllable, swift heat-up and high output.

The stylish good looks of the Compact are complemented by a heat transfer design which ensures the energy efficient utilisation of all expensive central heating fuels.

Over 100 models in the range, a Purmo Compact radiator is available to suit virtually every possible application and system design. Offered in both single and double configurations, with heights from 300mm to 700mm and a range of lengths from 400mm to 2300mm, Compact is a versatile and ideal partner for every central heating system boiler, whatever the fuel.

## **KEEN RADS IRELAND**

Blyry Industrial Estate, Athlone

Tel: 0902 - 78707

## Wilo Pumps – Continued Innovation and Design

Wilo Engineering Ltd, the Irish sales and distribution subsidiary of the German-owned Wilo Salmson AG Group, has been successfully serving the Irish building services market since 1980. The Limerick production facility, also established in 1980, employs over 150 people, and plays an important role in the success of the group worldwide.

Since its origin in 1872, Wilo has reached many landmarks in pump and circulator design, and development and production, for both building services and industry. Back in 1952, the first glandless circulators were produced, and in 1988 Wilo developed the Star 'E' Pump, the first electronic variable speed circulator of its kind with energy savings of up to 50% possible.

This achievement was further expanded in 1993 with the introduction of the TOP-E range, and again in 1997, when the first mechanical seal type variable speed pump range, the 'IPE' – with integral micro frequency converter – was launched. All of these ranges have since been further developed to offer twin pump versions.

On reflection over the last century some significant milestones have been surpassed in bringing the worldwide growth of the company to a turnover which is now in excess of £300 million per annum. This is serviced from six production centres, including the Limerick plant, and now includes 24 subsidiaries throughout the world.

Wilo glandless pumps – now with integrated isolating valves – Wilo continues to design,



The TOP-SV (and TOP-EV) range of glandless pumps is the first and only heating pump series with fully-integrated valves in the pump body

and innovate and expand its product ranges through the major in-house research and development centre at Dortmund Group headquarters. A typical example is the launch of the new TOP-SV and TOP-EV ranges of glandless pumps, the first and only heating pump series with fully-integrated isolating valves in the pump body.

These pumps, from DN25 to DN65, can reduce the overall space required by up to 50% compared to installations with separate isolating valves. The proven isolating concept utilises a butterfly flap valve on flanged pump models and ball valves on screwed connection models. The valves are easily accessible as they are positioned on the side of the pump housing, and require only a standard spanner to operate. There is an indicator on each

valve head, to show the valve position.

The TOP-SV range has 3-speed motors, and are similar in hydraulic performance to the current TOP-S pumps. The TOP-EV range features the electronically-controlled variable speed motors used on the successful TOP-E range. This concept brings about a new era in pump exchange whereby the pump housing – with its integral valves – remains installed and becomes part of the pipe system.

Wilo extended pump and equipment range – People involved in the building services industry will be familiar with Wilo's circulating pump ranges, but over recent years Wilo has developed and extended its product portfolio to include cold water pumps, submersible sewage pumps and packaged systems, heat



Wilo Pro-Comfort combined heating and hot water unit



PUMPS AND CIRCULATORS

exchange systems, pump controls and ancillary equipment.

Cold water boosters and boiler feed pumps – The MHI and MVI range of stainless steel multistage pumps are suitable for all water supply and pressure boosting applications such as mains water supply; fire hose reel and sprinkler services; boiler feed water; industrial circulating systems; process engineering; cooling water systems; and pressure-cleaning applications. As all wetted parts are available in stainless steel, the MHI and MVI pumps are approved for use with potable water supply and suitable for food-compatible fluids. The ranges cover flow rates of up to 60 m<sup>3</sup>/Hr and pressures of up to 230 metres, depending on selection. These pumps are also used on to the many booster sets assembled in Limerick and installed on numerous sites throughout Ireland for drinking water, potable water and fire fighting applications.

Variable speed options are also available, as is the new MVIS range of “super-silent” multistage pumps, which combine Wilo’s vertical multistage MVI range with their extensive glandless motor technology. The result is a glandless vertical multistage pump suitable for high-pressure applications, but with super silent operation in line with the glandless motor principle similar to that used on heating circulator pumps.

Drainage water and



The new Drainlift-S and Opti-Box units complement Wilo’s existing FH and D-FH range of commercial sewage systems

sewage applications – The Wilo range of quality submersible pumps includes the TM and the new TP and TS ranges. This now enables Wilo to offer a suitable submersible pump for all applications, from domestic storm and drainage water to raw sewage applications requiring pumps with large free-bore passage. The TS range is suitable for storm and drainage water applications with a max 10mm solids handling capacity. They are ideally suited to building and surface de-watering, domestic waste water disposal, and civil or process engineering schemes.

The TP range has a solids handling capacity of up to 100mm, depending on selection. Utilising single and twin vane impellers, they offer high operating reliability for applications such as storm/flood water removal, building de-watering, and dirty (grey) water applications, disposal of domestic sewage, commercial and industrial wastes, sludge and

untreated waste waters.

The TP 40 S macerating pump is also available from the new range. Its preferred application is for pressurised waste disposal systems where conventional gravity sewage disposal is uneconomical or not feasible. The patented macerator comprises an internal rotating cutter and conical fixed cutter that combines to disintegrate solid matter, ensuring choke-free displacement and maximum efficiency.

The common design features of both the TS and TP ranges are their surprisingly low weight, even on the large sizes. All motor housings are in 304 or 316 stainless steel. For added convenience, all models come with standard explosion-rated (EEx d II spec) motors and a detachable power cable. A full range of accessories such as duck foot bends, guide rail fittings and lifting chains are also available.

The new Drainlift-S and Opti-Box units complement Wilo’s existing successful FH and

D-FH range of commercial sewage systems, which offer a ready-to-connect packaged solutions for sewage disposal in office buildings, hotels, shops, or any commercial installation.

Packaged heat exchange systems – The Aqua-Net heat exchanger system is a complete heat exchanger package with pumps and integral controls, for applications which satisfy the hot water demands of modern systems, either for instantaneous supply or in conjunction with a storage vessel.

The Pro-Comfort combined heating and hot water unit is a packaged system which includes a heat exchanger/controls and a heat meter. This serves the application of monitoring and controlling the heat input and also the instantaneous hot water demand for group schemes such as apartments and domestic dwellings. It is a small, compact, wall-mounted unit, which fits neatly into each dwelling.

In this new millennium, with the benefit of Wilo’s past 128 years of experience, Wilo’s product range will continue to include the most advanced technology available, to maximise reduced energy consumption, reduce noise levels, and increase efficiency. Wilo will continue to innovate for the benefit of the installer, end user and the environment.

For a catalogue, or further details, contact Wilo Engineering Ltd. Tel: 061 - 410 963; Fax: 061 - 414 728; email: sales@wilo.ie

## RVR – The Energy Technology Specialists

The history of energy technology specialists RVR Ltd dates back to 1987 when the forerunner to today's operation was first established in Kenmare, Co Kerry. At the time it was established solely as a heating company, its Re-Verber-Ray brand becoming synonymous with gas-fired, infra-red heaters, especially for churches.

Over the years the company has undergone some significant changes, both in terms of ownership and management personnel, and in respect of the product portfolio. While Re-Verber-Ray is still an important part of RVR's business, it is now a much smaller element of the broader, greatly-diversified range.

Managing Director Michael Hayes has been associated with the company almost from the outset. He played a pivotal role during the initial years and was instrumental in overseeing its development, before finally leading a management buy-out in 1994.

Since then RVR has undergone quite a transformation with Michael and his fellow-director colleagues — Brendan O'Shea (production); Joanne Murphy (financial controller customer care); and Brian Mulhare (sales, based in Dublin) — devising and implementing a strategy which has led to the emergence of RVR as



VR high-efficiency air handling unit.

one of the leading market players in Ireland's building services sector.

Markets served are the 32 counties of Ireland, along with France, Italy and Spain where RVR has appointed sales agents/distributors. Apart from those already mentioned, Pdraig Blake and Pim Van Hoppe look after AHU sales and Stephen King looks after Northern Ireland.

Today RVR is truly an energy technology specialist, offering:

- air handling units;
- direct gas-fired air heaters;
- gas-fired infra-red heaters;
- indirect gas-fired air heaters.

There is also a range of complementary heating products and related accessories.

The company employs 30 people at present but this is set to increase as sales continue to rise. Substantial sums are invested in research and design with RVR's team of highly-qualified engineers firmly focussed on developing and bringing to the marketplace every-more-advanced product ranges offering still further customer benefits.

On the production side staff are experienced and highly-qualified, the ongoing training and educational programme ensuring that personnel get the maximum out of the computerised, state-of-the-art, manufacturing equipment.

The nationality mix of employees is something of a melting pot with Irish, English, Dutch and Germans all working side by side. This makes for a unique atmosphere at the Kenmare

plant and undoubtedly contributes to the progressive and outward-looking attitude that permeates the entire company.

Quality control takes precedence over all other activities. Strict procedures are adhered to at every stage in the production process with every single unit being fully tested to guarantee compliance with the CE Certification. Indeed, the fact that RVR has the authority to self-certify the CE mark is testimony to the fact that it operates to the highest quality control procedures.

Underpinning the entire effort is a dedicated Customer Care policy. This has always been a strong feature of the RVR offering but it has now been strengthened further with the appointment of Tadhg Condon to the position of Customer Care Manager. Tadhg has extensive experience in the customer care arena and brings with him the added benefit of having worked in the field for a number of multi-national companies.

When viewed in the context of the foregoing, it is easy to understand the success RVR has enjoyed since the management buy-out in 1994. Indigeneous manufacturing operations serving the Irish building services sector have always been a rare and endangered species. However, companies such as RVR are proof that this need not be the case.

Contact: Michael Hayes, RVR.  
Tel: 01 - 064 41344; Fax: 01 - 064 - 41511.  
email: rrvltd@rvr.ie ■

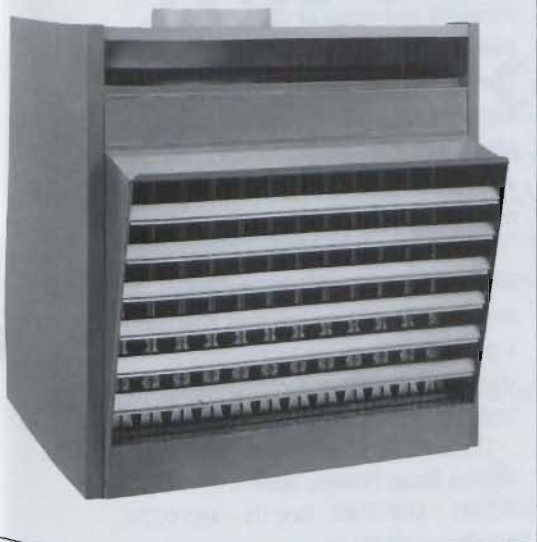

VR Centurion gas-fired unit heater.

DUCT CLEANING SERVICES BECOMES SIBS

## SiBS™ – Trusted Service Under a New Name

From 1 March next Duct Cleaning Services Ltd will operate under the new name of SiBS™, which stands for Specialist Independent Building Services. The name change was decided on to reflect the broadened range of specialist building services now being provided by the company, and to mark the beginning of a new expansionary phase in its operations.

Director Martin Deevy told *BSNews* as we went to press that existing customers, and new customers, can rest assured that the company will continue to deliver the reliable, high-quality service for which it is widely known while, at the same time, being better positioned to meet the changing and evolving needs of the marketplace.

Martin's fellow director and co-owner of SiBS™ is Brian Noone, with whom he conducted a management buyout to secure 100% ownership of the company. Martin was one of the original founding directors and has 15 years experience in HVAC and process system installation, commissioning, validation and hygiene maintenance. He ensures that all departments rigorously meet SiBS™ high standards of quality and service.

Brian joined the company in 1996, bringing with him extensive validation and commissioning experience in high-tech manufacturing facilities. He is the driving force behind the efficient organisation of the company's technical staff and customer relations service.

Both Martin and Brian are certified by NADCA, the US-based international professional body that tightly regulates industry standards. NADCA's stringent air system cleaning specialist certification is a significant achievement and an assurance of SiBS™'s comprehensive industry

knowledge and experience.

With building owners coming under increased pressure to provide acceptable levels of indoor air quality (IAQ), air change rates (total and fresh) and environmental control, SiBS™ offers a comprehensive range of specialist services to help them meet these requirements.

SiBS™ provides the following specialist services:

□ Ventilation hygiene services including CCTV services, risk

assessment and IAQ reports, as well as air duct cleaning using advanced equipment and techniques. SiBS™ specialises in the decontamination of process facilities, dust extractors, and the removal of chemically-treated ducts. Independent laboratories are used to analyse contaminant samples at the clients request.

□ Commissioning and validation services, including fan and pump performance testing, proportional balancing of air and water distribution systems, room-to-room differential pressure set-up, commissioning management, and independent witnessing services with comprehensive reporting. Professional commissioning of HVAC systems ensures operation within design parameters and optimum efficiencies.

□ HVAC and building maintenance services, ranging from short-term, fixed-price contracts to long-term placement of engineering and trade staff in large facilities.

"Looking to the future", says Martin, "we are committed to strengthening and developing the standard and value of the services we provide. We aim to achieve this by continuing to use state-of-the-art equipment, products and techniques, along with the implementation of strict quality control procedures and ongoing staff training programmes.

"Indoor air quality is emerging as a key health, environment and legal issue. SiBS™ will ensure that you take a proactive approach to creating a cleaner, healthier, more cost-effective, and safe environment".

Contact: Directors Martin Deevy and/or Brian Noone, SiBS™.  
Tel: 01 - 460 0740; Fax: 01 - 460 0720.  
email: [info@sibs.ie](mailto:info@sibs.ie)  
Website: [www.sibs.ie](http://www.sibs.ie) ■



# OZONE FRIENDLY HEATING & COOLING

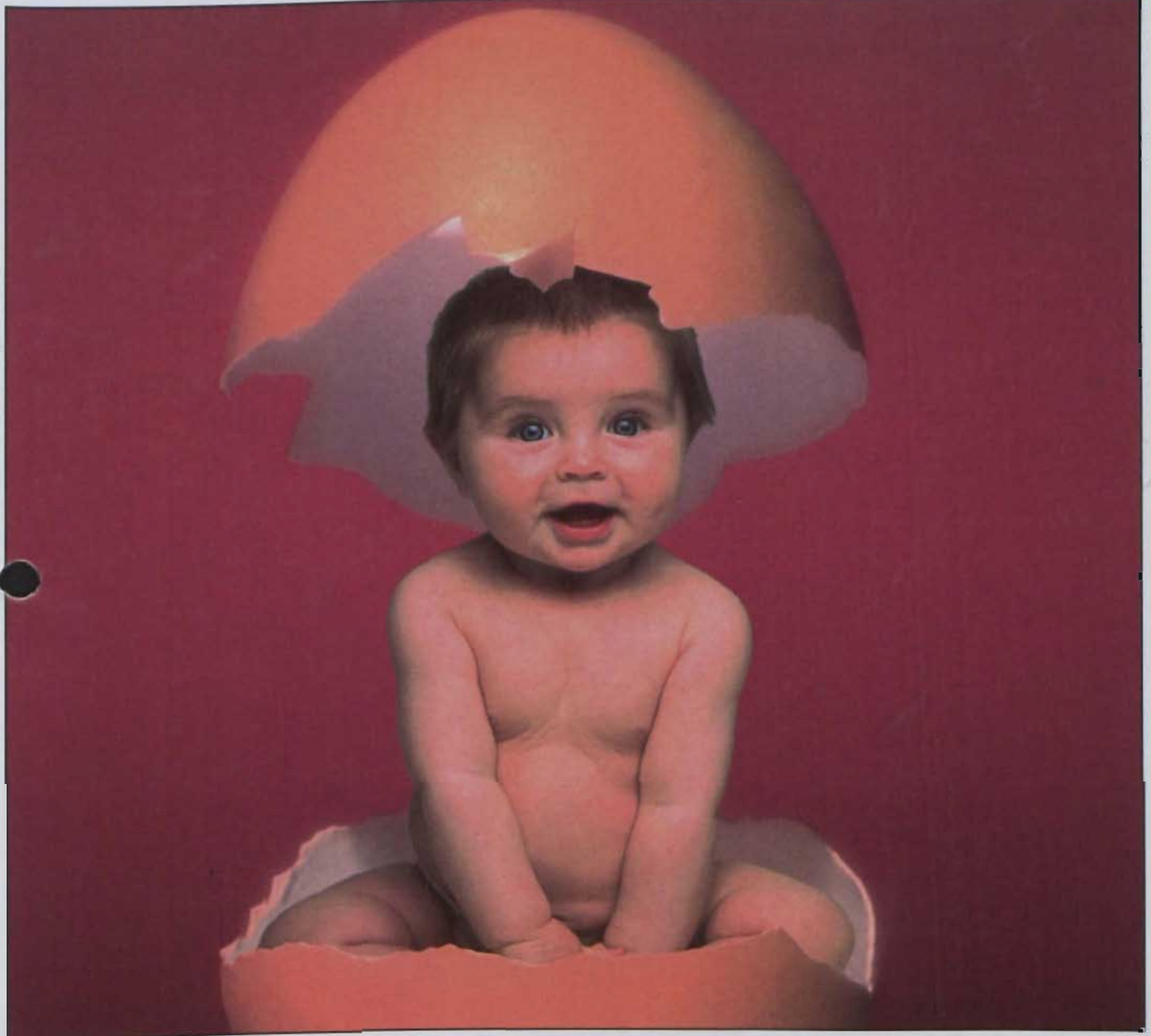

## Who else but **Mitsubishi Electric** could crack it?

It took years to develop but we finally cracked it. Introducing the new Next Generation range of ozone friendly air conditioning systems from Mitsubishi Electric. Featuring a new refrigerant gas that's harmless to the environment, the Next Generation is designed to help you live in comfort...with your world. At home and at work. The Next Generation range of ozone friendly air conditioning systems.

Only from Mitsubishi Electric.

To find out how our new systems can help you live in comfort by cooling or heating your world, contact:

 **MITSUBISHI ELECTRIC**  
**AIR CONDITIONING SYSTEMS**

**FREEFONE 1800 333 600**



**MANOTHERM LIMITED**  
THE CONTROL CENTRES

4 WALKINSTOWN ROAD, DUBLIN 12  
Tel: 01 452 2355/452 2229 Fax: 01 451 6919  
E-mail: manotherm@eircom.net  
U 15 BANBRIDGE ENTERPRISE CENTRE  
SCARVA RD IND. EST., BANBRIDGE BT32 3QD, CO DOWN  
Tel: 01820 669936 Fax: 01820 669990  
E-mail: sales@manotherm.freeserve.co.uk

**Dwyer**<sup>®</sup>

CONTROLS  
AND  
GAUGES

PRESSURE



FLOW



LEVEL



TEMPERATURE



DWYER

MERCOID

W.E. ANDERSON

LOVE

PROXIMITY