

The University of Southern Mississippi  
**The Aquila Digital Community**

---

Dissertations

---

Summer 8-2014

**Career Decision Status, Career-Related Thinking, and Emotional Distress: A Structural Equation Model**

Lindsey Marie Andrews  
*University of Southern Mississippi*

Follow this and additional works at: <https://aquila.usm.edu/dissertations>

 Part of the [Counseling Psychology Commons](#), [Industrial and Organizational Psychology Commons](#), [Personality and Social Contexts Commons](#), and the [Social Psychology Commons](#)

---

**Recommended Citation**

Andrews, Lindsey Marie, "Career Decision Status, Career-Related Thinking, and Emotional Distress: A Structural Equation Model" (2014). *Dissertations*. 276.  
<https://aquila.usm.edu/dissertations/276>

This Dissertation is brought to you for free and open access by The Aquila Digital Community. It has been accepted for inclusion in Dissertations by an authorized administrator of The Aquila Digital Community. For more information, please contact [Joshua.Cromwell@usm.edu](mailto:Joshua.Cromwell@usm.edu).

The University of Southern Mississippi

CAREER DECISION STATUS, CAREER-RELATED THINKING, AND  
EMOTIONAL DISTRESS: A STRUCTURAL EQUATION MODEL

by

Lindsay Marie Andrews

Abstract of a Dissertation  
Submitted to the Graduate School  
of The University of Southern Mississippi  
in Partial Fulfillment of the Requirements  
for the Degree of Doctor of Philosophy

August 2014

## ABSTRACT

### CAREER DECISION STATUS, CAREER-RELATED THINKING, AND EMOTIONAL DISTRESS: A STRUCTURAL EQUATION MODEL

by Lindsay Marie Andrews

August 2014

The choosing of a college major or occupation is an important decision with which many individuals struggle. Prior research has suggested that difficulty choosing a major or occupation affects a majority of students entering college and stems from multiple sources including lack of information, insufficient learning experiences, and ineffective decision-making processes. Cognitive-behavioral theory has shown utility in working with a diverse set of difficulties and with diverse populations through the examination of the influence of thoughts and emotions on resulting behavior. Research in the career literature has begun to emphasize connections between one's thoughts and emotions in regards to career development, including relationships found between negative career thoughts, feelings, and proponents of career decision status (e.g., Kelly & Shin, 2009; Saunders, Peterson, Sampson, & Reardon, 2000). The cognitive-behavioral model includes the domains of dysfunctional thoughts, mood, and behavior which will be measured by the presence of career-related thinking, emotional distress, and career decision status respectively. Therefore, the purpose of this study was to examine difficulties in choosing a major or career within the context of a cognitive-behavioral model in a sample of 200 undergraduate students. Through the use of structural equation modeling, it was found that the presence of negative career thoughts were highly instrumental in predicting difficulties in identifying a career choice. While emotional

components were highly correlated with both thoughts and career decision status, no direct relationship existed between affect and outcome. Therefore, it is suggested that interventions addressing career-related thinking may be beneficial in reducing difficulties in making a career choice, while focusing on emotional components may be helpful as well. Further, results of this study indicated that no differences existed between these relationships among diverse demographic groups based on gender, race, or college class standing. Implications for important future research and study limitations also are discussed.

COPYRIGHT BY  
LINDSAY MARIE ANDREWS  
2014

The University of Southern Mississippi

CAREER DECISION STATUS, CAREER-RELATED THINKING, AND  
EMOTIONAL DISTRESS: A STRUCTURAL EQUATION MODEL

by

Lindsay Marie Andrews

A Dissertation

Submitted to the Graduate School  
of The University of Southern Mississippi  
in Partial Fulfillment of the Requirements  
for the Degree of Doctor of Philosophy

Approved:

Emily B. Yowell

Chair

Bonnie C. Nicholson

Melanie E. Leuty

Richard S. Mohn

Maureen A. Ryan

Dean of the Graduate School

August 2014

## ACKNOWLEDGMENTS

The writer would like to thank the dissertation director, Dr. Emily Yowell, and the other committee members, Drs. Bonnie Nicholson, Richard Mohn, and Melanie Leuty, for their advice and support throughout the duration of this project.

## TABLE OF CONTENTS

ABSTRACT .....	ii
ACKNOWLEDGMENTS .....	iv
LIST OF TABLES .....	vi
LIST OF ILLUSTRATIONS .....	vii
CHAPTER	
I. INTRODUCTION	1
Career Decision Status	
Cognitive and Affective Influences on Career Decision Status	
A Cognitive-Behavioral Perspective	
The Present Study	
II. METHODOLOGY	29
Participants	
Measures	
Procedure	
III. RESULTS	40
Preliminary Analyses	
Confirmatory Factor Analyses	
Structural Equation Modeling	
Multigroup Analyses	
IV. DISCUSSION	47
Research Question 1	
Research Question 2	
Clinical Implications	
Limitations and Future Research Directions	
Summary	
APPENDIXES .....	66
REFERENCES .....	68



## LIST OF TABLES

Table

1. Demographic Characteristics of Sample .....	29
2. Means, Standard Deviations, and Correlations .....	41

## LIST OF ILLUSTRATIONS

Figure

1. Proposed Model .....	26
2. Hypothesized Model with Standardized Path Coefficients .....	44

## CHAPTER I

### INTRODUCTION

The decision surrounding the selection of a college major or occupation is an important and difficult process that affects most, if not all, individuals. As this decision is so pivotal in one's life and a measure of one's identity in society (Gottfredson, 2005), much research has focused on problems of career decision status. Career decision status, or career decidedness, has been described as "a continuous variable ranging from a self-perception of completely decided to completely undecided" (Jones & Chenery, 1980, p. 470). On one end of the spectrum is career indecision, which has been defined as an inability to make decisions related to the career one is interested in pursuing (Guay, Senecal, Gauthier, & Fernet, 2003). Career indecision is often described as stemming from a lack of information (Chartrand, Rose, Elliott, Marmarosh, & Caldwell, 1993) and is often viewed as the inability to choose a major or occupation at the university level or lacking effective career decision-making skills for individuals in general. Much research has been conducted on career decision status with findings that as many as 61% of college students enter college undecided about their career aspirations (Gordon, 2007). Additionally, further research has supported that even those students who have declared a major express some level of difficulty in making career-related decisions (Titley & Titley, 1980).

Many different conceptualizations of the manner in which various career constructs are related exist, with career decision status being at the forefront of many of these models. Career decision status can be influenced by a number of different factors including the individual having unsatisfactory or not enough previous experiences, as

well as not having an effective, systematic means of making career decisions (Krumboltz, Mitchell, & Jones, 1976). As will be the focus of the present study, a variety of internal issues may interfere with the decision-making process such as the presence of negative career-related thinking (Sampson, Peterson, Lenz, Reardon, & Saunders, 1996), low career-related self-efficacy (Betz & Voyten, 1997), or emotional distress (e.g., Fuqua, Newman, & Seqworth, 1988; Multon & Lapan, 1995). In addition to an individual's internal issues interfering with the decision-making process, societal influences have also impacted the way that individuals perceive and approach the decision of choosing a major or career (e.g., Gottfredson, 2005; Tansley, Jome, Haase, & Martnes, 2007). Technology, job market fluctuations, and increased importance of job-related identity further complicate the job decision-making process. Therefore, this career uncertainty might stem from both interpersonal (e.g., values, interests, skills) and environmental (e.g., economic situation, educational opportunities) factors.

To further discuss some of the potential internal issues that could impact decision making, career-related thinking and emotional distress have shown to impact one's progression through the career decision-making process. For instance, the cognitive information processing (CIP) approach (Peterson, Sampson, Reardon, & Lenz, 1996) acknowledges the importance of thoughts, emotions, and behaviors when solving career problems and making career-related decisions. In using this approach, interventions aim at identifying and targeting negative self-thoughts, in addition to the development of coping strategies (Sampson, Reardon, Peterson, & Lenz, 2004). Similarly, Tansley et al. (2007) asserted that "the more students' cognitive processes can be positively influenced, the more likely they will be successful in career decision-making-related tasks" (p. 302).

Sampson et al. (1996) asserted that negative career thoughts may interfere in the process of making a career decision or other career-related problem solving. Emotional aspects including state and trait anxiety, stress, and negative affective disposition have also been shown to relate to difficulties in progressing through the decision-making process (e.g., Fuqua et al., 1988; Multon & Lapan, 1995).

Additionally, career decision-making self-efficacy, an individual's beliefs about his or her capability to perform tasks related to the career decision-making process (Taylor & Betz, 1983), has been shown to be related to several career-related constructs including certainty (Betz, Klein, & Taylor, 1996), fear of commitment (Betz & Sterling, 1993), and adaptive career beliefs (Luzzo & Day, 1999). Further, the presence of negative career thoughts may lead to lower levels of self-esteem or perceived self-efficacy (e.g., Bullock-Yowell, Andrews, & Buzzetta, 2011; Kleiman, Gati, Peterson, Sampson, Reardon, & Lenz, 2004).

Although research has identified the prevalence of career decision-making difficulties among college students, Holland and Holland (1977) stated that "perhaps we have been too concerned with finding a few explicit variables and too little concerned with discovering the broad patterns suggested by a host of poorly defined variables" (p. 412). As research has supported relationships among cognitions, affect, and career decision status (e.g., Bullock, Peterson, Reardon, Leierer, & Reed, in press; Kelly & Shin, 2009), a model incorporating these cognitive-behavioral aspects will be examined to provide a means of viewing the construct of career decision status. Previous structural models will be reviewed later to help in constructing a model.

Cognitive-behavioral theory will be used as the basis for the construction of a new model due to the wide application and importance of similar constructs in vocational development literature. The cognitive-behavioral model incorporates the domains of distorted or dysfunctional thinking, mood, and behavior. The distorted thoughts are viewed as influencing an individual's mood and, therefore, behavior (Beck, 1995). Cognitive-behavioral theory (CBT) has been applied to diverse concerns, including eating disorders, depression, anxiety, and substance use, and has shown utility in providing an effective means of altering such presenting problems (e.g., Stewart & Chambless, 2009; Venning, Kettler, Elliott, & Wilson, 2009; Wilson, Grilo, & Vitousek, 2007). Additionally, research has begun to integrate CBT theory in the realm of career development and career problem solving. For example, Richman (1993) demonstrated the utility of cognitive-behavioral techniques (i.e., rational-emotive approach, allied cognitive-behavioral) through numerous career-related adjustments and decisions, including deciding whether to remain on the job and disengagement from one's career. Additionally, as already indicated, the CIP approach emphasizes the importance of thoughts and emotions in the decision-making process similar to the emphasis on these constructs in CBT. In the CIP approach, one's thinking is seen as influencing how that individual perceives and processes career-related information, thereby impacting whether approach or avoidance behaviors are the result. The impact on behavior is similar to that found in CBT where one's thoughts influence how the individual behaves. Further, emotional experiences (e.g., anxiety, depression) are viewed as one of the means by which an individual identifies that a decision is to be made in the CIP approach. Therefore, according to the CIP approach both one's emotions and thoughts influence the

individual's progression through making career decisions and solving career-related problems. Similarly CBT rests on the premise that thoughts and emotions determine resulting behavior. Therefore, both the CIP approach and Richman (1993) have shown the importance of CBT-like components in career decision making and other important career development processes.

The purpose of this study is to demonstrate further relationships among emotional distress and career-related thinking in the context of career decision making. The structural relationship among these variables (i.e., emotional distress, career-related thinking, career decision status) will be examined to provide a bigger picture and create a model of the relationships among several seemingly related constructs and to help in bridging the gap between research and practice by providing a theoretical perspective in examining the relationships among these variables. Examining the relationships among the constructs will add to further understanding of an individual's career development through understanding the complexity of the difficulties and the relationship of cognitive, affective, and behavioral domains. In this study, the components of CBT will be identified as follows: career-related thinking will compose the cognitive or distorted thinking component, emotional distress will compose the affective component, and career decision status will compose the behavioral component.

The following sections will further introduce the variables of interest in the study in addition to a review of relevant literature. First, research relevant to career decision status will be discussed with specific attention paid to relationships between career decision status and negative affective experiences and thinking. Second, cognitive-behavioral theory will be introduced, as well as studies demonstrating the relation of this

perspective to the domain of career-related concerns. Lastly, the construction of a theoretical model will be described.

### Career Decision Status

In this study, career decision status is used to describe the range of decidedness with which an individual presents and, as stated, can range from undecided to declaring one main choice. Sampson et al. (2004) stated that career decision status has been conceptualized as falling into one of three categories, which includes decided, undecided, and indecisive statuses (Sampson et al., 2004) although other conceptualizations exist as well. In Sampson et al.'s conceptualization of this continuous construct, the decided individual has confirmed a specific occupational choice. Although these individuals have a primary choice that they are working toward, they may continue to consider or rule-out other options as well as need assistance in implementing the primary choice (Sampson et al., 2004). The indecisive individual has not made a commitment to a specific occupational choice. This lack of commitment may be due to lack of sufficient information, as well as a problematic approach to decision making in general, accompanied by high levels of anxiety.

Undecided individuals are similar to those who are indecisive in that they have not made a specific occupational choice due to lack of information needed to make a choice. Sampson et al. (2004) identified three subcategories of undecided individuals: deferred choice, developmental, and multipotential. Individuals labeled as deferred choice are seen as being unable to identify a specific choice; however, they do not need to make a choice at this time. For example, a freshman in college often does not need to have decided upon a specific career path, but rather can defer this decision until he or she



has gained additional knowledge and life experiences. Developmentally undecided individuals are those who need to make a decision, but are unable to commit due to lack of knowledge. Lastly, the multipotential individual is undecided due to having multiple talents, interests, and opportunities, thereby complicating the already difficult nature of this decision.

Although the undecided and indecisive categories are similar in this manner, several differences exist between individuals falling in these categories. Osipow (1999) identified that someone who is undecided can be differentiated from indecisive based on whether the difficulties are a normal aspect of development, with indecisiveness indicating an abnormal problem with making a decision. Specifically, Osipow asserted that indecisiveness generalizes across decision-making situations, whereas indecision is a natural part of human development. As such, the nature of being undecided, a normal aspect of one's development, leads to an increased effort into exploration and goal setting, further differentiating those who are undecided from those who are more indecisive in general. Salomone (1982) asserted that the state of being undecided tends to stem from lack of information, as already noted. Indecisive individuals, however according to Salomone, fail to make decisions due to the presence of personal qualities that "will not allow them to reach a decisional state of mind and take a course of action" (Salomone, 1982, p. 497). Further, indecisive individuals are described as those facing identity crises and substantial anxiety. Salomone provided a warning, however, on labeling anyone younger than approximately 25 as indecisive, recounting that individuals develop differently and at different rates.

Many studies use the term *career indecision* to reflect the lack of a solid choice, with career indecision having been defined in the context of problems encountered during the career decision-making process (Germeijs & de Boeck, 2003) and viewed as a normal and developmentally appropriate response to stressors (Creed, Patton, & Prideaux, 2006). Gianakos (1999) estimated that as many as half of all students experience difficulties in establishing a primary career choice at some point. As career decision making is a developmental process, differences would be expected between individuals at different developmental stages. However, research has not supported this assertion. A group of 166 students participated in a two-part study taking place during grades 8 and 10 (Creed et al., 2006). The results found that, contrary to previous literature, a change in one's confidence in performing tasks necessary for making a career choice was not associated with change in career decision status or vice-versa at grade 10. Further, career decision status at time two was best predicted by the presence at time one. Additionally, Tokar, Withrow, Hall, and Moradi (2000) examined differences between participants who were ages 21 years and younger and those over 21 on the relationships among psychological separation, attachment security, vocational self-concept, crystallization, and career decision status. Although differences were found to exist between the two groups, Tokar et al. concluded that the differences were not meaningfully different between the two groups and therefore combined the older and younger participants into a single sample group for further analyses. Lack of differences were found, as well, in a sample of 465 junior high and senior high level students when examining career decision status across the two groups by grade levels (Vondracek, Hostetler, Schulenberg, & Shimizu, 1990). Thus, it appears that research has failed to find significant and meaningful differences

when examining career decision status across different academic levels, lending little support to career decision being a developmental process. Although lack of differences have been found in these studies, the current study will examine the potential for differences relative to college class standing, specifically between upper and lower classman. As the present study proposes a new model and uses multiple means of conceptualizing and measuring latent variables, further information may be found regarding the potential for differences.

As stated, career decision status has been conceptualized in various ways, including the three categories of decided, undecided, and indecisive (Sampson et al., 2004). In addition to examining career decision status as an overall construct, this construct has also been viewed as involving various different subtypes (Holland & Holland, 1977; Larson, Heppner, Ham, & Dugan, 1988; Sampson et al., 2004). Often regarded as a “complex, multidimensional construct” (Gordon & Meyer, 2002, p. 32), difficulties in choosing a career are seen as representing different components, or subtypes, of being undecided, which have not been agreed upon in the literature. Larson et al. (1988) identified four subtypes of indecision through the use of a cluster analysis. These four types included what the researchers labeled planless avoiders, informed indecisive, confident but uninformed, and uninformed. These are similar to the earlier mentioned categories of undecided individuals (i.e., deferred choice, developmental, and multipotential) as identified by Sampson et al. (2004).

In a similar manner, Holland and Holland (1977) assessed for differences in several career-related variables, including personality, decision-making abilities, interests, and vocational attitude. The subjects were college juniors identified as decided

or undecided by responses to items regarding having made a tentative occupational choice and being employed full time. The participants were alike on most variables, but undecided individuals lacked a clear sense of identity when compared to those identified as decided. Holland and Holland discussed the presence of three types of indecision found in college students and asserted that the undecided may not reflect nearly one group of individuals, but may be viewed more accurately as being comprised of multiple categories of difficulties encountered. These categories were identified by clusters of items endorsed as explanations for being undecided or dissatisfied and were consistent with previous literature. The first category that was identified was those who do not feel pressured to make a career decision, similar to deferred choice undecided individuals. A majority of those identifying as undecided endorsed not needing to make a decision at the moment as the cause for their indecision. A second category of undecided individuals was described as those who are slightly to moderately immature, incompetent, anxious, or alienated. Lastly, those with maladaptive attitudes and coping behaviors who are moderately to severely immature, incompetent, anxious, or alienated comprised the final category. As the research has shown, there are several different difficulties encountered that can result in an individual delaying the choice of a specific career path.

Additionally, the results of Holland and Holland further supported previously reviewed literature that has described that decided and undecided individuals are similar across many diverse career-related variables (e.g., personality, interests). Undecided students did demonstrate a less clear sense of identity and vocational maturity than those identified as decided in this study.

*Career Decision Status Research and Models*

Additional studies have shown career decision status to be related to several career and personality variables. In regards to career-related variables, career decision status has been related to fear of commitment (Leong & Chervinko, 1996), rational decision-making style (Mau, 1995), career barriers (Patton, Creed, & Watson, 2003), self-knowledge (Gati & Saka, 2001), and self-efficacy beliefs (e.g., Betz & Luzzo, 1996; Betz & Voyten, 1997). Career decision status has also shown relationships with the variables of perfectionism, self-consciousness (Leong & Chervinko, 1996), career maturity (Rojewski, 1994), anxiety (e.g., Campagna & Curtis, 2007; Fuqua et al., 1988), and ego identity (Cohen, Chartrand, & Jowdy, 1995). Additionally, personal and interpersonal variables such as gender and age (Patton & Creed, 2001), negative affective disposition (Multon & Lapan, 1995), poor social skills (Nota & Soresi, 2003), and positive family and peer interactions have been shown to relate to one's career decision status as well (e.g., Felsman & Blustein, 1999; Guerra & Braumgart-Rieker, 1999). Career decision status has also been found to be directly related to the Big Five factors of agreeableness and conscientiousness, while negatively correlated with neuroticism (Lounsbury, Tatum, Chambers, Owens, & Gibson, 1999). Therefore, it can be seen that career decision status is a complex variable with relations to several, diverse variables and aspects of one's life.

Several studies have also begun to examine the impact of several diverse correlates of career decision status through the use of structural equation modeling and other path analyses. Gaffner and Hazler (2002) identified self-efficacy, locus of control, and anxiety to be contributing factors to career decision status in undergraduate students.

In a study utilizing structural equation modeling, Creed, Patton, and Bartrum (2004) found that career decision-making self-efficacy, optimism, self-esteem, and pessimism significantly predicted career decision status in men, while none of these variables were able to predict the presence of indecision for the women participants.

Many of these models integrate cognitive and affective aspects in explaining career decision status (e.g., Hammond, Lockman, & Boling, 2010; Kelly & Shin, 2009; Smith & Betz, 2002). For example, one study found career self-efficacy, career-related emotional maturity, information needs, vocational identity development, and career decisional status to be related to career decision status for African American students (Hammond et al., 2010). Career-related thoughts and feelings were also shown to explain variance in career decision status, specifically with regards to lack of information (Kelly & Shin, 2009). Thus, prior research has begun to show the connection between one's thoughts, emotions, and behaviors in the realm of career decision status.

Research in the area of career decision status is often criticized as lacking a theoretical basis (Chartrand et al., 1993). One application of a theoretical perspective involves Brown and Ryan Krane's (2000) tripartite model of career indecision. This conceptualization involves the three higher order factors of negative affect, low vocational identity development, and lack of career information. In this model, vocational identity development includes aspects such as vocational identity, career maturity, goals, and self-efficacy for making a career decision. Hammond et al. (2010) examined the fit of Brown and Ryan Krane's tripartite model in a sample of African American college students to determine if the model is race-specific as the development of this model (Brown & Ryan Krane, 2000) had included mainly European American

individuals. Hammond et al. found that a different model did produce a better fit in the sample of African Americans than the original model proposed by Brown and Ryan Krane. The model that produced a better fit included two of the three original factors proposed by Brown and Ryan Krane (i.e., negative affectivity and information needs), as well as the addition of emotions. The findings of this study appear to support that different models exist for African American and European American college students in examining career decision status in this manner. Other applications of theory to career decision status include research that has asserted that career-related thoughts are a large component of one's career decision status based on the theoretical work of Beck (Saunders, Peterson, Sampson, & Reardon, 2000) as well as indications that insufficient information about potential alternatives, problems surrounding valuing, and uncertainty about the outcomes are the three factors that influence levels of career decision status as supported by decision theory (Germeijs & de Boeck, 2003).

Tinsley (1992) stated that “despite the research attention given this construct in the past decade, indecision remains an atheoretical construct about which relatively little is known” (p. 210). By incorporating a theoretical perspective that has been shown to be effective in numerous difficulties and whose components have been included in various vocational literature into the framework of this study, the construct of career decision status can be better understood through the widely known CBT perspective with regards to the development and interplay of thoughts and emotions in relation to difficulties in making career decisions.

## Cognitive and Affective Influences on Career Decision Status

Barriers to one's career choice have been described as internal conflicts or external frustrations that impede the individual in attaining his or her career goals (Crites, 1969). Examples of internal barriers may include low self-confidence or a lack of motivation, while external barriers may include limited educational opportunities, interpersonal workplace abuse, or geographic restriction. Many different conceptualizations of the barriers to career decision making have been hypothesized (Farmer, 1976; Harmon, 1977; O'Leary, 1974; Swanson & Tokar, 1991) with each perspective including both external and internal barriers. The current study seeks to examine the influence of internal barriers, specifically cognitive and affective factors, as possible deterrents to career decision making in an effort to better understand the relationship of one's thoughts and emotions in the career decision-making process.

### *Cognitive Influences*

Creed et al. (2004) asserted that one's cognitive style would influence whether a barrier is viewed as challenging or defeating. Prior research has demonstrated the relationship among cognitive constructs and career development, including optimism. Optimism, a tendency to expect positive outcomes, has been related to increased career planning and exploration (Creed, Patton, & Bartrum, 2002), as well as shown to be related to internal barriers such as self-esteem (Creed et al., 2004). Although Creed and colleagues examined the influence of optimism and pessimism, other types of cognitive processes have also shown to have relationships to one's career development and are more commonly referred to in the career development literature. Literature most relevant to the proposed study's constructs will be reviewed, including information related to the



cognitive variables of career-related thoughts and career decision-making self-efficacy in relation to the career decision-making process.

*Career-related thinking.* Negative career thinking, sometimes referred to as dysfunctional career thinking, includes viewing oneself in a manner that “inhibits career problem solving and decision making” (Sampson et al., 1996, p. 2). This manner of negative thinking stems from the emphasis that cognitions are likely to impact one’s behaviors and emotional experiences as introduced by Beck (1972). Little research to date has examined relationships among thoughts involved in the decision-making process and career development outcomes.

The presence of negative career-related thoughts has been hypothesized to limit one’s ability to make rational career decisions when progressing through the decision-making process (Sampson et al., 1996). Several studies have discussed the effects of career-related thinking during the process of making a career decision on one’s confidence to complete tasks necessary to making a career choice (e.g., Bullock-Yowell et al., 2011; Hartman & Betz, 2007; Kleiman et al., 2004). Bullock-Yowell et al. (2011) reported a negative relationship between career decision-making self-efficacy and negative career thoughts in a study of 322 undergraduate students. These findings further support that negative career-related thinking is related to one’s confidence, often leading to avoidance behaviors associated with low self-efficacy (Bandura, 1986).

Career-related thoughts are inferred through endorsements of perceived attitudes, behaviors, feelings, and career strategies. The CIP approach to decision making, as previously described, asserts that the presence of several negative thoughts may lower one’s capability and thus readiness to establish a career choice. Individuals presenting

with several negative thoughts are likely to require greater assistance in the job search process (Sampson et al., 2004). Previous research has linked career-related thinking with career decision status (Saunders et al., 2000). The findings of Saunders et al. (2000) demonstrated that career-related thinking accounted for significant variance in career decision status, with state and trait anxiety, locus of control, vocational identity, depression, and negative career thoughts accounting for 69% of the total variance. Although all of these constructs were found to be interrelated and highly correlated with career decision status, Saunders et al. (2000) stated that only vocational identity and negative career thoughts accounted for independent variance in career decision status. A further study of multiple irrational beliefs provided additional support for the relationship between career-related thinking and career decision status. Stead, Watson, and Foxcroft (1993) found that irrational beliefs regarding an overemphasis on worry about other's problems or not yet experienced misfortunes were related to career decision status. The authors also discussed the relationship with anxiety found previously in the literature related to these two components. Therefore, previous literature has supported interrelationships between anxiety, negative thinking, and career decision status, lending additional support for a cognitive-behavioral framework and assertion of connection between thoughts, emotions, and career decision status.

Career-related thinking during the process of making a career decision may influence an individual at various stages of the career decision-making process. Kleiman et al. (2004) found a significant correlation between negative career thoughts and career decision-making difficulties ( $r = .82$ ) in a sample of 192 university students. However, limitations in the homogeneity of the sample (i.e., 73% European American) make

generalizability of these results somewhat limited. Negative career-related thoughts can cause difficulties throughout various stages of the career decision-making process, making the relationship between the two constructs important when intervening with clients.

*Career decision-making self-efficacy.* Bandura's (1977, 1986) self-efficacy theory combines affective, biological, and cognitive influences, explaining that an individual's perceptions of his or her capabilities are developed and modified through four sources: performance accomplishments, vicarious learning, emotional arousal, and verbal persuasion. Bandura's theory of self-efficacy was first introduced into the career domain by Hackett and Betz (1981) through the examination of college students' beliefs about educational and occupational capabilities. Social cognitive career theory (SCCT; Lent, Brown, & Hackett, 1994) focuses on the influence of cognitive components in career decision making and is an expansion of Bandura's (1977) cognitive work. The SCCT asserts that self-efficacy beliefs, outcome expectations, and personal goals influence how individuals decide upon academic majors and career paths. This concept of self-efficacy has further been integrated into the career realm (e.g., Betz & Hackett, 1981, 1983; Betz, Harmon, & Borgen, 1996), with career decision-making self-efficacy being the most extensively researched.

Career decision-making self-efficacy, an individual's confidence about his or her ability to successfully complete tasks specific for effective career decision making (Betz, Klein et al., 1996), has also been linked to career decision status (e.g., Betz & Voyten, 1997) and other career-related variables, including fear of commitment (Betz & Sterling, 1993) and adaptive career beliefs (Luzzo & Day, 1999). Betz and Voyten (1997) found

that career decision-making self-efficacy was related to career decision status, with self-efficacy predicting 19% and 28% of the variance in indecision for women and men, respectively. Although the scores on the measures were not significantly different between the two groups, the degree to which they were related to career decision status did. Further, Betz and Vuyten found that higher levels of career indecision were related to exploratory intentions in women, but not men.

High levels of career decision-making self-efficacy have been shown to be related to further progression in the career decision-making process. For example, Betz, Klein, et al. (1996) found that career decision-making self-efficacy is correlated with certainty. In a similar vein, Robbins (1985) found that scores on career decision-making self-efficacy could differentiate individuals identified as high and low on vocational identity, a construct often used interchangeably with career decision status. Further, Taylor and Popma (1990) demonstrated that levels of career decision-making self-efficacy could be utilized to distinguish declared major, tentative major choice, and undecided undergraduate students.

As previously stated, many atheoretical models exist examining correlates to career decision status. Guay et al. (2003) proposed a model asserting that self-efficacy and autonomy in the career decision-making process would have a direct impact on career decision status. The results of this study indicated that experiences with peers and parents of the college students predicted career indecision through career decision-making self-efficacy and autonomy toward career decision-making activities regardless of gender.

Several studies have identified means of increasing levels of career decision-making self-efficacy influenced by the seeming importance of this construct in career decision making. Methods emphasizing the four sources of self-efficacy (i.e., performance accomplishments, vicarious learning, emotional arousal, verbal persuasion) have been shown to be effective in this goal. Specifically, utilizing verbal persuasive messages (e.g., Luzzo & Day, 1999; Luzzo, Funk, & Strang, 1996; Luzzo & Taylor, 1993), as well as using attributional retraining procedure (Luzzo et al., 1996), a form of verbal persuasion, have been shown to increase career decision-making self-efficacy. Sullivan and Mahalik (2000) also demonstrated the effectiveness of Bandura's (1986) four sources of self-efficacy in increasing career decision self-efficacy and vocational exploration and commitment over the course of a six-week group intervention. The authors found that long-term changes in overall self-efficacy were obtained through the use of the four sources of self-efficacy as compared to a control group. Research on career decision self-efficacy has supported that long-term changes in self-efficacy can be obtained through using the four sources of self-efficacy as well as demonstrating the importance of understanding one's career-related thinking on the decision-making process and career decision status.

### *Emotional Influences*

As stated previously, career decision status has been linked to several emotional constructs including state anxiety (e.g., Campagna & Curtis, 2007; Fuqua et al., 1988) and negative affective disposition (Multon & Lapan, 1995). Spokane (1989) has further suggested that when stress related to making a career decision exceeds an individual's resources for coping, emotional difficulties may result.

*Anxiety.* Anxiety has been found to be related to career decision status. Research has demonstrated that indecisive college students were more anxious than decided students (e.g., Kaplan & Brown, 1987; Kelly & Pulver, 2002). Goodstein (1965) discussed that anxiety may result from one's inability to make a career decision or may be the cause of these difficulties with decision making. Hutri and Lindeman (2002) discussed the impact of anxiety in occupational crises, or the "loss of the sense of who one is vocationally" (p. 20). Occupational crises involve a desire to change jobs or occupations to avoid intense feelings of anxiety brought on by aspects of their work, possibly resulting in decreased effectiveness, absences, quitting, or psychological distress (Hutri & Lindeman, 2002). The authors reported relationships among trait anxiety, as well as suppressed anger and depressive symptoms with the presence of occupational crises.

Hawkins, Bradley, and White (1977) examined the relationship among anxiety and career decision status. In a sample of 427 students, inverse relationships were found between anxiety and having made a vocational choice. The researchers examined four types of anxiety (i.e., general, major choice, vocational choice, decision), finding that anxiety related to choosing a major and general anxiety predicted whether a student had chosen a major accounting for 8.9% and 1.5% of the variance in indecision, respectively. Kimes and Troth (1974) additionally examined the relationship among career decision status and anxiety. In a sample of 829 college students, five levels of career decision status were demonstrated (i.e., decided on a career, tentatively decided, moving towards a decision, career in mind but not moving toward a decision, completely undecided). Trait

anxiety was higher for those who were completely undecided or had a career in mind but not moving towards a decision than those who had decided on a career.

Fuqua et al. (1988) examined the relationships among both state and trait anxiety with career decision status in a sample of 349 college students. Four factors of career indecision were identified and included (1) lack of information about self and careers, (2) lack of information of how careers related to one's interests, values, and abilities, (3) multiple interests leading to difficulties deciding, and (4) the presence of barriers. Both trait and state anxiety were related to three of these factors, with no significant relationships existing with difficulties due to multiple interests. Fuqua et al. (1988) further examined the relationships, finding that factor 1 was the only factor with a greater correlation with trait anxiety rather than state anxiety. Thus, this study demonstrated that individuals with greater levels of anxiety endorsed greater career indecision, with state anxiety having a greater correlation than trait anxiety for two of the groups of students (i.e., lack of information regarding how careers relate to one's interests, values, and abilities; the presence of external barriers). In addition to demonstrating relationships with career decision status, research has also demonstrated that higher levels of career decision-making self-efficacy are related to lower levels of anxiety (Robbins, 1985).

*Depression.* Antony, Bieling, Cox, Enns, and Swinson (1998) explained that previous literature has further demonstrated that intercorrelations between depression and anxiety exist, despite assertions that these constructs are distinct, separate entities. Relationships among depression and career decision status have also been demonstrated. Hutri and Lindeman (2002) stated that depression tends to be related to perceptions of loss or lack of reward. The authors additionally presented findings that suppressed

depressive symptoms, in addition to trait anxiety and suppressed anger, were related to occupational crises in a sample of employed Finnish adults.

Smith and Betz (2002) asserted that “sense of personal control and successful adaptation is, in turn, an important buffer against depression” (p. 438) and stems from one’s perceived self-efficacy. The results of Smith and Betz’s study of college students demonstrated that depressive symptoms were related to both career decision-making self-efficacy and self-esteem through the mediating variables of career indecision and shyness. Career decision status was shown to have a small, direct relationship to depressive symptoms in this sample. Additionally, relationships between the cognitive and emotional components have been demonstrated. Sampson et al. (2004) found that negative career thoughts, as measured by the Career Thoughts Inventory, have been positively correlated with the depressive facet of the neuroticism domain of the NEO Personality Inventory-Revised (NEO-PI-R; Costa & McCrae, 1992) in a sample of 152 undergraduate students. This finding can be taken to demonstrate that the relationship between negative emotions and career-related thoughts in the realm of career decision making are closely related, which will be further discussed in the following section. Additionally, the relationships among cognitions, emotions, and career decision status further support the inclusion of these components in the creation of a model, as well as the cognitive-behavioral framework proposed.

#### A Cognitive-Behavioral Perspective

The current study will examine the construct of career decision status within the framework of a cognitive-behavioral perspective. This section will provide a brief



overview of this approach and review the literature connecting this approach to the realm of vocational guidance.

CBT is a comprehensive and eclectic therapeutic practice drawing from both cognitive and behavioral principles. CBT is characterized by the influence of thoughts and emotions on behavioral outcomes based primarily on Beck's (1987) cognitive theory. Beck (1972) emphasized the role that one's cognitions play in emotional and behavioral responses to events. According to the proponents of this theory, a situation or event triggers certain types of thoughts, which in turn produce emotional reactions. Based on these two factors (i.e., thoughts; emotions), an individual is influenced to respond in a certain way. In cognitive therapy, clients are taught to identify, evaluate, and respond to negative thoughts and underlying beliefs. Thus, the purpose of this approach is to correct errors in thinking, thereby changing the resulting emotional and behavioral components as well.

The premise of the CBT model is that a decrease in maladaptive, negative thoughts and, therefore, disabling emotions will lead to a change in behaviors. Individuals are taught to notice, catch, monitor, and interrupt automatic thoughts, which are spontaneous statements that occur without effort or pretense and represent an individual's perception of a situation. Examining these automatic thoughts provides a window for viewing the client's core schemas. Meichenbaum asserted that affect and behavior are largely influenced by the way one constructs the world, identifies oneself in the environment, tests reality, and corrects maladaptive and distorted beliefs (Meichenbaum & Cameron, 1982). Another theorist, Ellis (1962), asserted that thoughts produce emotion so that cognition mediates experience and resulting behavior.

Conceptualizations of CBT emphasize the importance of identifying thoughts, elicited emotions, and resulting behaviors in an effort to change negative thoughts tied to previous experiences.

As previously mentioned, CBT has been noted as an effective approach for use with several presenting problems including vocational difficulties. Additional evidence for the applicability of this theory to the realm of career decision status was supported by relationships found between career decision-making self-efficacy, outcome expectations, and career decision status using multiple regression, which provided support for “the essential relationships between thoughts and behavior” (Betz & Vuyten, 1997, p. 188). Further, Kelly and Shin (2009) incorporated components important in CBT in their model and found that negative career thoughts and feelings, including anxiety and neuroticism, predicted 66.9% of the variance in lack of information, a large component of career decision status. Kelly and Shin (2009) found that gender did not influence relationships among neuroticism, negative thoughts and feelings, and lack of information.

Bullock et al. (in press) further demonstrated the connection among cognitions, emotion, and career decision status. They found that career-related thoughts mediated the relationship between career and life stress and career decision status in a sample of 232 undergraduate students enrolled in an introductory career development course at a large southeastern university. Thus, the presence of negative career thoughts hinders the process of making a career decision and is an important piece in explaining difficulties in decision making.

Saunders et al. (2000) examined the presence of cognitions in the career decision-making process as well. This study examined the influence of depression and negative

thinking in the presence of career decision-making difficulties in a sample of undergraduate students. The authors, in examining the role of depression and negative thinking, partitioned out variance attributed to vocational identity, anxiety, and locus of control. Vocational identity, state and trait anxiety, locus of control, depression, and negative career thoughts together were found to predict 68% of career indecision. Negative career thoughts alone were found to predict an additional 10% of variance above the 59% captured by the control variables. Depression did not explain any additional significant variance in career decision status above the other variables. The authors asserted that difficulties in career decision status, (i.e., career indecision) appear to be comprised of “both cognitive and affective variables that are in themselves highly interrelated and ostensibly interactive” (Saunders et al., 2000, p. 295). Therefore, Saunders et al. (2000) found that career-related thoughts play an important role in the presence of career decision status. While emotional constructs (e.g., depression) were also found to be highly related to both the cognitive aspects and the decision state, these components did not provide additional significant variance to the model. However, the authors asserted that there is much overlap in regards to the variables that were measured, and a pure measure of any of these components may not exist due to the nature of the variables. Thus, the proposed model is further supported by the Saunders et al. study, which demonstrated relationships among cognition, affect, and career decision status, as well as the correlation and overlap between cognitions and emotions.

The literature has demonstrated the relationships among cognitive and affective constructs in predicting the state of one’s level of career decision status. While these connections have been made, the literature so far appears to have focused on very

specific aspects of these constructs (e.g., anxiety, depression) and included other factors as well in developing models or relationships to one's career decision status.

### The Present Study

The current study proposes a model (see Figure 1) utilizing components of CBT (i.e., cognition, affect, resulting behavioral state). As stated previously, the CBT cognition component will be defined through career-related thinking. Additionally, the affect component will be emotional distress and the behavioral component defined as career decision status.

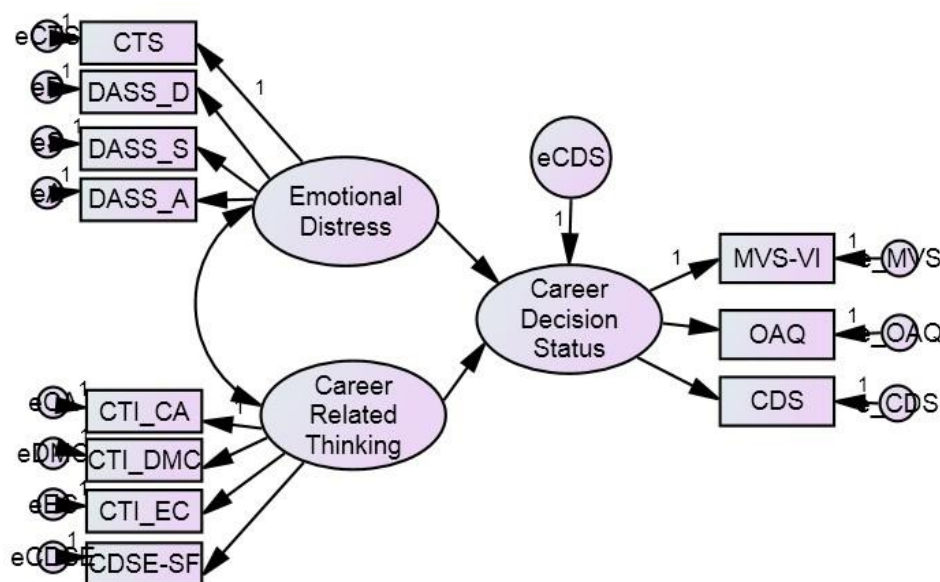

*Figure 1.* Proposed Model. CTS = Career Tension Scale; DASS-D = Depression, Anxiety, and Stress Scale – Depression; DASS-S = Depression, Anxiety, and Stress Scale – Stress; DASS-A = Depression, Anxiety, and Stress Scale – Anxiety; CTI-CA = Career Thoughts Inventory Commitment Anxiety; CTI-DMC = Career Thoughts Inventory Decision-Making Confusion; CTI-EC = Career Thoughts Inventory External Conflict; CDSE-SF = Career Decision Self-Efficacy Scale – Short-Form; CDS-IND = Career Decision Scale – Indecision; MVS-VI = My Vocational Situation - Vocational Identity.

Career decision status has been shown to be influenced by diverse career and personality variables. Prior relationships with self-efficacy beliefs (e.g., Betz & Luzzo,

1996; Betz & Vuyten, 1997), anxiety (e.g., Campagna & Curtis, 2007; Fuqua et al., 1988), negative affect (Multon & Lapan, 1995), and negative career thoughts (e.g., Lounsbury et al., 1999; Saunders et al., 2000) have provided the basis for the use of a cognitive-behavioral perspective examining career-related thinking and emotional distress in the prediction of one's career decision status. The proposed model differs from prior research by combining several diverse studies, in addition to being more comprehensive in how the variables are defined and measured. The present study also includes variables and measures that are more career-focused than previous research related to career decision status.

The present study aims to add to the career development literature through further examination of constructs related to career decision status through the theoretical perspective CBT (Beck, 1995). As previously described, authors have cited the lack of theoretical rationale related to career decision status to be a major limitation in this area (Chartrand et al., 1993). Cognitive-behavioral theory is a useful and practical means of viewing and intervening with individuals with many different presenting problems, including difficulties in committing to a college major or career choice. This study hopes to provide an additional means of conceptualizing this difficulty that is often encountered with college students through examining a comprehensive model of cognitive, emotional, and behavioral factors that result in differing degrees of career decision status.

Additionally, differences among gender, race, and college class standing will be examined due to the discrepant findings for these groups found in the literature (e.g., Creed et al., 2004; Creed et al., 2006). Thus, the following research questions were explored: (1) How do general level of emotional distress and negative career thoughts

predict a causal relationship with level of career decision status? (2) Do diverse (i.e., gender, race, college class standing) backgrounds of individuals differ in the best fitting model between these variables of interest?

*Statistical Hypotheses:*

The following research hypotheses were explored in this study:

- 1) High levels of general emotional distress will be moderately directly related to the level of difficulties in one's career decision status (e.g., indecision, undecided) about career or major of study options.
- 2) The presence of negative career-related thoughts will be moderately directly related to level of difficulties in one's career decision status (e.g., indecision, undecided) about career or major of study options.
- 3) Emotional distress and negative career-related thinking will be positively correlated with one another.
- 4) Men and women will not differ in either the measurement or proposed model.
- 5) African American and European American participants will not differ in either the measurement or proposed models.
- 6) Lower classmen and upper classmen will not differ in either the measurement or proposed model.

CHAPTER II  
METHODOLOGY

Participants

A total of 200 undergraduate students enrolled in a midsized southeastern university were recruited (see Table 1). Participants of the study included 157 females and 43 males (78.5% and 21.5%, respectively), ranging in age from 18 to 52 ( $M = 21.07$ ,  $SD = 5.69$ ). The racial make-up of the sample included 111 European American (55.5%) and 89 African American (44.5%) participants.

Table 1

*Demographic Characteristics of Sample*

Characteristic	<i>n</i>	%
Gender		
Female	157	78.5
Male	43	21.5
Ethnicity/Race		
Black/African American	89	44.5
European American	111	55.5
Class Status		
Freshman	83	41.5
Sophomore	43	21.5
Junior	37	18.5
Senior	37	18.5
Satisfaction with Major		
Well satisfied with choice	90	45.0
Satisfied, but have a few doubts	78	39.0
Not sure	15	7.5
Dissatisfied and intend to remain in my major	1	0.5
Dissatisfied and intend to change my major	7	3.5
Undecided about my future major career	9	4.5

Individuals participating in the study ranged in undergraduate classification including 41.5% freshmen ( $n = 83$ ), 21.5% sophomores ( $n = 43$ ), 18.5% juniors ( $n = 37$ ), and 18.5% seniors ( $n = 37$ ). Over 97% of participants indicated that they have considered what field they would like to major in or what occupation they would choose. Participants endorsed more than 40 different majors and varied in their satisfaction with these majors. Specifically, 45.0% of participants ( $n = 90$ ) endorsed being well satisfied with their choice, 39.0% ( $n = 78$ ) were satisfied but with a few doubts, 7.5% ( $n = 15$ ) were unsure, 0.5% ( $n = 1$ ) were dissatisfied and intend to remain in the major, 3.5% ( $n = 7$ ) were dissatisfied and intend to change majors, and 4.5% ( $n = 9$ ) were undecided about a major. Thus, the sample appears to have been decided and satisfied overall.

### Measures

*Demographic form.* This questionnaire was utilized to gather basic demographic information including gender, race, and age. Additionally, demographic information regarding academic studies was requested including college class standing and major.

#### *Measures Used to Assess Career Decision Status*

*Career Decision Scale.* The Career Decision Scale (CDS; Osipow, Carney, Winer, Yanico, & Koschier, 1987) is a 19-item self-report measure assessing one's career decision status. It is scored on a four-point scale ranging from *not at all like me* (1) to *exactly like me* (4), with higher scores indicating greater levels of indecision for the participant. The basis for the CDS was to assess difficulties with career indecision by examining numerous sources that may interfere with this process. The authors compiled a list of reasons individuals may have indecision when faced with difficulties in the career decision-making process. Sixteen of the items assess for career indecision, while



two items assess for certainty of career choice, and a single open-ended, non-scored question measures concerns about career decision (Osipow, 1987). Only the 16 items measuring career indecision were utilized to partially define the latent variable, career decision status. Example items include “Several careers have equal appeal to me. I am having a difficult time deciding among them,” and “I cannot make a career choice right now because I do not know what my abilities are.”

Hartman, Fuqua, and Hartman (1983) reported an internal consistency coefficient alpha of .80 for the 16-item Indecision Scale, while other studies have found that reliabilities range from .82 to .89 (Osipow, 1987). Cronbach’s alpha for the Indecision Scale in the current sample was found to be .90. Osipow, Carney, and Barak (1976) reported test-retest reliability for the CDS over a period of two weeks ranged from .82 to .90. Other research has demonstrated evidence of convergent validity through relationships with the Career Decision Profile (Stead & Watson, 1993). The CDS has also shown utility across several ethnic groups including African American, Asian, Hispanic, and Native American individuals (Fuqua et al., 1988; Meyer & Winer, 1993).

*My Vocational Situation.* My Vocational Situation (MVS; Holland, Daiger, & Power, 1980) is a 26 question measure assessing readiness for career choice. Eighteen of the items require respondents to indicate whether the statement is mostly *true* (1) or mostly *false* (0) regarding their present position or planning for their career. Such items include “I am confused about the whole problem of deciding on a career” and “No single occupation appeals strongly to me.” Additionally, two items present participants with the opportunity to identify several statements regarding needing further information and encountering difficulties as being present (i.e., *Yes* = 1) or not (i.e., *No* = 0). The premise

of the MVS is that difficulties in career decision making fall into three categories: vocational identity problems (VI), lack of occupational information (OI), and external or internal barriers (B). Only the VI subscale, which includes 18 items, was utilized to partially define the latent variable, career decision status.

The VI subscale assesses if an individual possesses a clear and stable idea of goals, interests, personality, and talents. Scores range from 0 to 18 with higher scores indicating higher levels of career decidedness. According to Holland et al. (1980), having high vocational identity leads to effective decision making, as well as confidence in oneself to make decisions despite the existence of barriers. Holland et al. (1980) reported internal consistency ranging from .86 to .89. Lucas, Gysbers, Buescher, and Heppner (1988) found that the test-retest reliability for a period of three to five months was .64. Cronbach's alpha for the VI subscale in the current sample was found to be .90.

Construct validity was established through small to moderate correlations between the three MVS subscales and participant age, number and variety of occupational aspirations, and external ratings of a sample of 824 high school, college, or business participants. Holland, Johnston, and Asama (1993) and Lucas et al. (1988) reached the conclusion that the MVS has adequate evidence of construct validity, as it identifies individuals who have a clear picture of goals and are better able to make effective career decisions.

*Occupational Alternatives Questionnaire.* The Occupational Alternatives Questionnaire (OAQ; Zener & Schnuelle, 1972; modified by Slaney, 1980) is a two-item measure of level of career indecision. Items include "List all the occupations you are considering right now" and "Which occupation is your first choice? If undecided, write

undecided.” The OAQ is scored on a scale of 1 to 4, with higher scores indicating a greater degree of indecision. The OAQ is scored using the following alternatives: 1 = a first choice is listed with no alternatives, 2 = a first choice is listed with alternatives, 3 = no first choice is listed, just alternatives, and 4 = neither a first choice nor alternatives are listed. The OAQ has demonstrated concurrent validity with other measures of career decision status including the Satisfaction with Career Scale, the Vocational Decision Making Difficulties Scale, and the Indecision subscale of the Career Decision Scale (Slaney, 1980; Slaney, Stafford, & Russell, 1981). The total score was used to partially define the latent variable, career decision status.

*Measures Used to Assess Career-Related Thinking*

*Career Thoughts Inventory.* The Career Thoughts Inventory (CTI; Sampson et al., 1996) is a 48-item self-report measure used to assess content and degree of negative career thinking in adults, college students, and high school students. The CTI assesses the presence of career thoughts that may inhibit or impede decision making in each of the CIP domains (i.e., self-knowledge, occupational knowledge, decision-making skills, executive processing) and includes items such as “I’ll never understand enough about occupations to make a good choice,” and “I’m afraid if I try out my chosen occupation, I won’t be successful.” Participants respond on a four-point Likert-scale ranging from *strongly disagree* (0) to *strongly agree* (3). The total score identifies the level of difficulties in career problem solving and decision making due to the presence of negative thinking, with raw scores ranging from 0 to 144 (normative data of college students:  $M = 47.01$ ,  $SD = 20.90$ ). Higher scores indicate the presence of greater negative

thinking, which is likely to inhibit or impair one's ability to make career decisions and solve career-related problems.

The CTI additionally includes scale scores that measure issues of career thinking related to decision-making confusion (DMC), commitment anxiety (CA), and external conflict (EC). The DMC subscale is comprised of 14 items and reflects an "inability to initiate or sustain the decision making process as the result of disabling emotions and/or a lack of understanding about the decision-making process itself" (Sampson et al., 1996, p. 28). The CA subscale includes 10 items assessing an "inability to make a commitment to a specific career choice, accompanied by generalized anxiety about the outcome of the decision-making process" (Sampson et al., 1996, p. 28). The EC subscale consists of five items and reflects an "inability to balance the importance of one's own self-perceptions with the importance of input from significant others, resulting in a reluctance to assume responsibility for decision making" (Sampson et al., 1996, p. 29). The current study utilized the three subscales, and not the CTI total score, as observed measures of the latent variable, career-related thinking.

The literature demonstrates high levels of internal consistency in each of the three groups the measure assesses (i.e., high school students, college students, adults). In a sample of college students, the internal consistency coefficient alphas for the CTI subscales were found to be .82 for DMC, .79 for CA, and .74 for EC (Sampson et al., 1996). Alphas for the current sample were found to be .95 for DMC, .90 for CA, and .80 for EC.

Research has supported evidence of validity of the CTI. Content validity was ensured through the writing of the CTI items to be consistent with thoughts that may

interfere with progressing through the stages of a career decision-making model (Sampson et al., 2004) and, therefore, the content is in line with this approach to career decision making. Another method of validating the CTI was through demonstrated relationships between the CTI and other measures theorized to be related, thus providing additional support for construct validity. Both the overall and subscale scores of the CTI were negatively related to the Certainty subscale and positively correlated with the Indecision subscale of the Career Decision Scale (CDS; Osipow et al., 1987). Additional construct validity was supported through three factors accounting for 47.3% of the variance. Further, criterion validity was supported through the total score differing between college students seeking career services and those who were not.

*Career Decision Self-Efficacy Scale – Short Form.* The Career Decision Self-Efficacy Scale – Short Form (CDSE-SF; Betz, Klein et al., 1996) is a 25-item measure assessing an individual's self-efficacy expectations for completing tasks necessary in making career-related decisions. The measure consists of five items from each of the five scales comprising the full-length measure (Taylor & Betz, 1983). Participants respond to each of the items, including “Accurately assess your abilities” and “Decide what you value most about an occupation,” on a five-point confidence continuum ranging from *no confidence at all* (1) to *complete confidence* (5). Total scores can range from 25 to 125, with higher scores indicating greater confidence in one's ability to successfully complete tasks necessary for making career decisions. Different conclusions about the generalizability of the overall scores have been found when examining differences across ethnic groups in levels of career decision-making self-efficacy. Studies have found that European American participants endorse greater levels of self-efficacy (Gloria & Hird,

1999), while others assert that no significant differences exist between racial groups (Chaney, Hammond, Betz, & Multon, 2007; Chung, 2002). Also, Betz, Klein et al. (1996) found that no significant differences across gender existed when examining overall levels of the construct. Therefore, men and women are assumed to perform similarly in beliefs about one's capability to complete these necessary tasks.

In addition to a total score, the CDSE-SF is comprised of five subscales: Self-Appraisal (SA), Occupational Information (OI), Goal Selection (GS), Planning (PL), and Problem Solving (PS). This five-factor structure has shown minimal support (e.g., Betz & Luzzo, 1996; Taylor & Popma, 1990) and, therefore, only the total score was used in the current study to partially define the latent variable, career-related cognitions. The CDSE-SF scored on the five-point continuum has been found to have coefficient alphas ranging from .93 to .95. Cronbach's alpha for the total score in the sample was found to be .97.

Content validity has been established through the construction of the measure based on Crites' (1969) theory of career maturity. Yet factor analysis has only marginally supported a five-factor structure. Concurrent validity has been demonstrated through correlations with both the Indecision ( $r = -.19$  to  $-.66$ ) and Certainty ( $r = -.03$  to  $-.76$ ) scales of the Career Decision Scale. Construct validity has been supported through relationships to career decision status and vocational identity (Betz, Klein et al., 1996; Betz & Sterling, 1993). Additionally, the CDSE has been shown to distinguish between individuals at different places in the career decision-making process (Neimeyer & Metzler, 1987; Robbins, 1985).

*Measures Used to Assess Emotional Distress*

*Career Tension Scale.* The Career Tension Scale (CTS; Reed, 2005) is a seven-item measure of resulting distress stemming from the pressure to make a career decision. This measure was created by modifying items from a job tension scale developed by House and Rizzo (1972), which examined relationships between working and physical and emotional health concerns, including nervousness, worry, and sleeplessness. Reed (2005) altered the items to reflect relationships between career decisions and the same health concerns. Participants respond to items, including “Decisions about my career tend to directly affect my health,” and “Problems associated with my career decisions have kept me awake at night,” on a seven-point Likert-type scale ranging from *strongly disagree* (1) to *strongly agree* (7). An individual’s score is the arithmetic average of the items. Higher scores indicate greater stress or tension in making a career decision and are indicated by the arithmetic average of the items. High internal consistency has been demonstrated among college students, with prior studies showing alphas of .81 (Reed, 2005; see also Bullock et al., in press). Cronbach’s alpha for the total score in the current sample was found to be .88. This total score was used to partially define the latent variable, emotional distress.

*Depression, Anxiety, and Stress Scale – 21.* The Depression, Anxiety, and Stress Scale (DASS-21; Lovibond & Lovibond, 1995) is a 21-item self-report measure of distress assessing the areas of depression, anxiety, and stress. Examples of items found on the measure include “I find it hard to wind down,” and “I felt down-hearted and blue.” Participants respond on a four-point scale ranging from *did not apply to me at all* (0) to *applied to me very much, or most of the time* (3) as each item applies to the past week.

There are seven questions measuring each of the three areas, with scores ranging from 0 to 21. Higher scores indicate the presence of greater occurrence of the symptoms for each area. As each of these areas varies on a continuum, ranges are provided defining mild, moderate, severe, and extremely severe scores by multiplying the subscale scores by two for depression, anxiety, and stress. All three scores were used to partially define the latent variable, emotional distress.

The DASS has been shown to have strong internal consistency. In a sample of 49 nonclinical participants and 258 outpatient participants diagnosed with various depressive and anxiety disorders, Cronbach alphas were .94 for depression, .87 for anxiety, and .91 for stress (Antony et al., 1998). Alphas for the current sample were found to be .89 for depression, .85 for anxiety, and .87 for stress. The full length version of the DASS has demonstrated a two-week test-retest reliability ranging from .71 to .81 (Brown, Chorpita, Korotitsch, & Barlow, 1997). Convergent validity has been supported through relationships with the Beck Depression Inventory ( $r = .74$  with DASS depression subscale) and the Beck Anxiety Inventory ( $r = .81$  with DASS-42 anxiety subscale; Lovibond & Lovibond, 1995).

Evidence of construct validity has been supported through the examination of correlations between the DASS-21 Depression, Anxiety, and Stress subscales and several other assessments measuring similar constructs, namely the Beck Depression Inventory ( $r = .62 - .79$ ), the Beck Anxiety Inventory ( $r = .51 - .85$ ), and the State-Trait Anxiety Inventory – Trait version ( $r = .55 - .71$ ) (Antony et al., 1998). Additionally, a factor analysis further showed support for the three factor structure (Lovibond & Lovibond, 1995). Further, DASS-21 scores were examined across five diagnostic groups (panic



disorder, obsessive-compulsive disorder, social phobia, specific phobia, and major depressive disorder) in addition to a nonclinical group. Antony et al. (1998) provided support of concurrent validity through findings that those diagnosed with major depressive disorder scored highest on the depression and stress subscales, and those with panic disorder scored highest on the anxiety subscale.

### Procedure

The study was approved by the Human Subjects Review Committee of the Institutional Review Board (see Appendix A). Participants were recruited through the university's online system, which offers students enrolled in psychology undergraduate courses extra credit for participation in research studies. Participants were directed to the online survey through a link on the Department of Psychology's research website, which was linked to a survey created and available through PsychSurveys ([www.psychsurveys.org](http://www.psychsurveys.org)). Participants were given informed consent (see Appendix B) through the first page of the web survey, which provided a brief description of the study, benefits, and limitations. Participants were notified that continuing to the next page indicated consent to participate in the experiment. After agreeing to participate and being informed about the study, a demographic form, the Career Decision Scale, the Career Decision Self-Efficacy Scale – Short Form, the Career Tension Scale, the Career Thoughts Inventory, the Depression, Anxiety, and Stress Scale – 21, My Vocational Situation, and the Occupational Alternatives Question were administered in varied order to account for order effects. The study required approximately 60 minutes of time and, upon completion, participants were awarded research credit in courses of their choice for their participation in the study.

## CHAPTER III

### RESULTS

#### Preliminary Analyses

Missing data were replaced utilizing linear trend at point procedure. Forty data points across 29 items were replaced using this method. Descriptive statistics for pertinent scale scores and total scores were calculated and can be found in Table 2. Scores indicated that the participants overall were decided as to a major and had few cognitive or affective concerns. Means indicated the presence of low levels of career indecision, vocational identity problems, negative career thinking, depression, anxiety, tension, or stress in making career decisions, in addition to the presence of high career decision-making self-efficacy.

Examining Mahalanobis distance was also utilized to test for the presence of outliers. Descriptive and fit statistics were examined with and without the input from four participants and analyses indicated that the results did not materially change when examining the coefficients; therefore, all 200 participants were retained in the following analyses.

#### Confirmatory Factor Analyses

Additionally, confirmatory factor analyses (CFA) were conducted to provide support for the measures utilized in the study to represent the latent variables. Higher order CFAs were additionally run to provide support for utilizing the measures to represent the latent variables of Emotional Distress, Career-Related Thinking, and Career Decidedness. Fit statistics indicated a good fit of the items to the latent variables and are described below.

Table 2

*Means, Standard Deviations, and Correlations*

Variable	1	2	3	4	5	6	7	8	9	10
1. CTS	--									
2. DASS-D	.43**	--								
3. DASS-S	.50**	.74**	--							
4. DASS-A	.47**	.76**	.76**	--						
5. CTI-CA	.40**	.35**	.29**	.30**	--					
6. CTI-DMC	.39**	.42**	.27**	.40**	.76**	--				
7. CTI-EC	.39**	.31**	.32**	<b>.39**</b>	.60**	.62**	--			
8. CDSE-SF	-.23**	-.31**	-.18*	-.26**	-.40**	-.49**	-.31**	--		
9. CDS-IND	.38**	.38**	.26**	.36**	.69**	.71**	.57**	-.42**	--	
10. MVS-VI	.40**	.30**	.23**	.27**	.71**	.67**	.48**	-.53**	.67**	--
M	2.77	7.12	10.79	6.40	9.89	7.31	3.51	95.24	26.58	6.92
SD	1.38	8.38	9.01	7.89	6.90	7.66	3.13	19.29	9.02	5.29
Range	1-7	0-32	0-38	0-38	0-25	0-33	0-15	25-125	16-56	0-18
Possible Range	1-7	0-42	0-42	0-42	0-30	0-42	0-15	25-125	19-76	0-18
Sample Alphas	.88	.89	.87	.85	.90	.95	.80	.97	.90	.90

Note. CTS = Career Tension Scale; DASS-D = Depression, Anxiety, and Stress Scale – Depression; DASS-S = Depression, Anxiety, and Stress Scale – Stress; DASS-A = Depression, Anxiety, and Stress Scale – Anxiety; CTI-CA = Career Thoughts Inventory Commitment Anxiety; CTI-DMC = Career Thoughts Inventory Decision-Making Confusion; CTI-EC = Career Thoughts Inventory External Conflict; CDSE-SF = Career Decision Self-Efficacy Scale – Short-Form; CDS-IND = Career Decision Scale – Indecision; MVS-VI = My Vocational Situation – Vocational Identity.

\* $p < .05$ . \*\* $p < .01$ .

Testing of the model was conducted through the use of AMOS 20. For testing the global model fit, four indices were utilized: chi-square, comparative fit index (CFI),

Tucker-Lewis index (TLI), and root mean square error of approximation (RMSEA). Chi-square examines the goodness-of-fit of a model. This comparison, which is dependent upon the sample size, is used in difference testing to determine if significant differences exist between nested models (i.e., those models that have the same number of variables). The CFI is used to compare a specified model and a model in which the latent variables (or unobserved variables) or indicator variables are correlated. Adequate fit is met for values of .90 and above, while above .95 indicates a good fit. The TLI provides a slight adjustment for parsimony. Fit is considered adequate if it exceeds .90 and a good fit if it is above .95. The last index that will be used for comparison among specified models is the RMSEA. A fit of less than .08 is considered reasonable, while below .05 is considered a good fit.

Measurement models were evaluated to determine how well the administered measures combined to represent the latent constructs of the model. To provide support for the latent variable of Career-Related Thinking, the measurement model utilizing the four observed variables hypothesized to represent this domain (i.e., CTI-CA, CTI-DMC, CTI-EC, CDSE-SF) produced marginal fit ( $\chi^2_{1371} = 3139.79, p < .001$ ; CFI = .79; TLI = .78; RMSEA = .08). Adding a higher order latent variable provided a similar fit ( $\Delta\chi^2(2) = 1.69, p > .05$ ) with no significant difference in fit statistics (Cheung & Rensvold, 2002). Therefore, support was provided for using a higher order factor to represent the items.

In an effort to support the use of the latent variable Emotional Distress, a higher order CFA was conducted. A measurement model using the four scales of CTS, DASS-D, DASS-S, and DASS-A produced an adequate fit ( $\chi^2_{344} = 869.89, p < .001$ ; CFI = .84; TLI = .83; RMSEA = .09). Adding the higher order latent variable produced a similar fit

( $\Delta\chi^2(2) = 2.84, p > .05$ ), providing support for utilizing the latent variable, Emotional Distress, in the model.

As the variable OAQ included only one item, it was not included in the measurement model. The model including the scales CDS-IND and MVS-VI was found to have an adequate fit ( $\chi^2_{526} = 1101.60, p < .001$ ; CFI = .80; TLI = .79; RMSEA = .07). A higher order CFA adding both the indicator variable OAQ and the latent variable Career Decidedness ( $\Delta\chi^2(32) = 35.88, p > .05$ ) provided a similar fit and was therefore retained in testing the proposed model.

Therefore, fit statistics indicated support for the latent variables of Emotional Distress, Career-Related Thinking, and Career Decidedness through the use of a second order CFA. These latent variables were used to further test the proposed model as described below.

### Structural Equation Modeling

After conducting CFAs to support the validity of the measures utilized, the measurement model was tested to ensure that relationships existed between the variables of interest prior to restricting the direction of such relationships. The measurement model contained three latent constructs: career-related thinking, emotional distress, and career decision status. The measurement model produced a good fit of the data ( $\chi^2_{41} = 101.89, p < .001$ ; CFI = .95; TLI = .93; RMSEA = .09).

The loadings of the measured variables on the latent variable were significant ( $p < .01$ ) and ranged from .22 to .88, indicating that each of the latent variables was adequately measured by the instruments. The OAQ, a two-item measure, produced the lowest loading (i.e., .22), while all others were above .54.

The next step involved testing the direct effect between career-related thinking and emotional distress on career decision status. This step tested direct paths from both career-related thinking and emotional distress to the construct of career decision status to examine whether these two latent variables predicted one's level of career decidedness. As the proposed model included the same number of paths, the fit statistics remained the same, and therefore, the proposed model produced a good fit for the 200 participants included in the sample. The standardized path coefficients can be found in Figure 2.

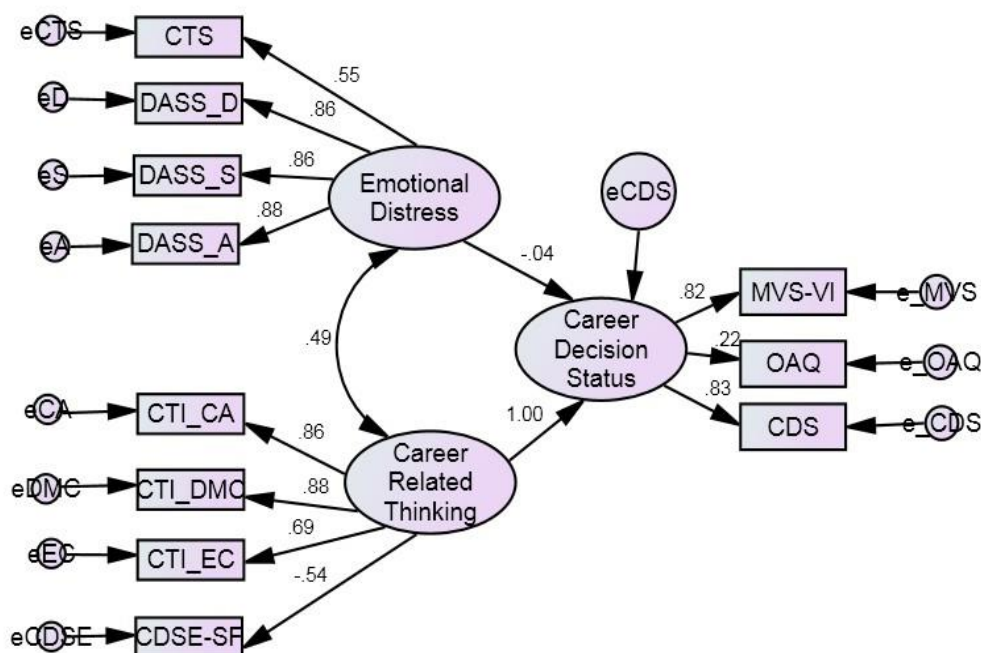

*Figure 2.* Hypothesized Model with Standardized Path Coefficients. CTS = Career Tension Scale; DASS-D = Depression, Anxiety, and Stress Scale – Depression; DASS-S = Depression, Anxiety, and Stress Scale – Stress; DASS-A = Depression, Anxiety, and Stress Scale – Anxiety; CTI-CA = Career Thoughts Inventory Commitment Anxiety; CTI-DMC = Career Thoughts Inventory Decision-Making Confusion; CTI-EC = Career Thoughts Inventory External Conflict; CDSE-SF = Career Decision Self-Efficacy Scale – Short-Form; CDS-IND = Career Decision Scale – Indecision; MVS-VI = My Vocational Situation - Vocational Identity.

### Multigroup Analyses

Finally, differences between groups of individuals based on demographic variables were examined to determine if the proposed model (see Figure 1) fits equally well with diverse groups (i.e., race, gender, college class standing). Invariance testing was conducted by comparing chi-square values between models for statistical significance. Factor loadings were constrained to be equivalent across group and compared to a model in which all variables were allowed to vary. When examining the model with respect to gender, men and women were similar in their fit when constraining factor loadings ( $\Delta\chi^2(8) = 5.62, p > .05$ ), the correlation ( $\Delta\chi^2(1) = 0.64, p > .05$ ), and the paths ( $\Delta\chi^2(2) = 1.08, p > .05$ ). Similarly, upper and lower classman participants' scores fit similarly when factor loadings ( $\Delta\chi^2(8) = 11.17, p > .05$ ), the correlation ( $\Delta\chi^2(1) = 2.80, p > .05$ ), and the paths ( $\Delta\chi^2(2) = 0.12, p > .05$ ) were constrained. No significant differences existed between the best fitting model for men and women ( $p > .05$ ) or upper and lower classman ( $p > .05$ ). Significant findings were upheld between African American and European American participants ( $\Delta\chi^2(8) = 15.65, p < .05$ ) when examining the change in model fit when the factor loadings were constrained. However, upon further analyses, no significant differences were found for any of the latent variables when they were examined separately. Further, examining additional nested models while constraining the correlation ( $\Delta\chi^2(1) = 0.40, p > .05$ ) as well as the paths ( $\Delta\chi^2(2) = 0.66, p > .05$ ) did not produce significant differences between these two groups. Therefore, as the probability was very near the cutoff and no additional differences were examined, there is not enough support to reject the hypothesis that these two groups do not differ in

regard to the proposed model. In other words, the model structure is equivalent across groups.



## CHAPTER IV

### DISCUSSION

The present study examined cognitive and affective components in relation to career decidedness. Prior research demonstrated convergent relationships among career decidedness and multiple constructs, including emotional concerns (Saka & Gati, 2007), negative career thoughts (e.g., Saunders et al., 2000), and external (e.g., parental interest, finances, current school) and internal (i.e., self-esteem) barriers (Creed et al., 2004). Thus, the influence of aspects of the individual as well as outside sources impact and relate to one's level of decidedness regarding career choice. This study sought to further knowledge of the construct of career decision state by utilizing theory and previous literature.

The underpinnings of cognitive-behavioral theory were utilized to construct and conceptualize the model, with the domains of thoughts, emotions, and resulting behavior being included. To specify the cognitive-behavioral structure to career development, three latent variables were composed to represent each of the domains. Career thoughts comprised the thoughts domain. Emotional distress was the variable name used for the more general emotions domain. Finally, career decidedness composed the resulting behavioral domain.

#### Research Question 1

The construction of this model was used in answering the first research question, which focused on whether general level of emotional distress and career-related thoughts would interact to predict a causal relationship with level of career decision status.

In order to examine this causal relationship, each of the relationships among these latent constructs was examined. The first hypothesis stated that high levels of general

emotional distress will be moderately directly related to the level of difficulties in one's career decision status about career or major of study options. Contrary to expectations, the structural path for emotional distress to career decision status was not significant ( $\beta = -.044$ ;  $p = .45$ ). This finding is incongruent with prior research demonstrating that negative affective components (e.g., anxiety, depression) aid in explanation of significant variance in career indecision (e.g., Kelly & Shin, 2009; Saunders et al., 2000). However, negative emotions were found to be highly correlated with and combined with other cognitive components in creation of prior models. For example, Kelly and Shin (2009) proposed a latent variable of negative career thoughts and feelings, while Saunders et al. (2000) asserted the presence of a high degree of colinearity among cognitive and affective variables that made it difficult to separate them completely. This finding may be affected by the sample that was recruited in the current study, which is a highly satisfied, low distress group.

The latent variables, emotional distress and career decision status, were not significantly correlated with one another. Yet, endorsements of the observed variables of general emotional distress and career decision status were significantly correlated with one another. Analyses confirmed that measures assessing career tension (i.e., CTS), depression (i.e., DASS-D), stress (i.e., DASS-S), and anxiety (DASS-A) were correlated with observed endorsements of career indecision (i.e., CDS-IND), vocational interest (MVS-VI), and degree of commitment to a career (i.e., OAQ). These findings are consistent with research that identified relationships between emotional distress (e.g., anxiety, depression) and career indecision (e.g., Fuqua et al., 1988; Hawkins et al., 1977; Kimes & Troth, 1974; Smith & Betz, 2002). These results extend prior research of

specific types of emotional distress and various constructs related to career decidedness; however, no relationship was established between the higher-order factors of emotional distress and career decidedness. To summarize, in the current proposed model the latent variable of emotional distress was not directly related to the level of difficulties in one's career decision status. However, correlations between observed emotional and career decision status variables indicated a tendency for these variables to covary, indicating an emotional component to career-related difficulties. Thus, although the cognitive and affective constructs were related, the cognitive aspects were a better predictor of career decision status. A sample including a more dissatisfied group may have shown different results, with emotions predicting a greater proportion of career decision status.

In support of the second hypothesis, negative career-related thoughts were directly related to one's career decision status. The latent variables of career-related thoughts and career decision status were highly related ( $\beta = 1.00, p < .001$ ), indicating the strong cognitive component of career decision status in the current model. The extent of this relationship indicates the strong cognitive component to career decision status and may, in fact, indicate that these two latent variables represent the same construct. Previous literature has supported a strong cognitive component in determining one's level of career decidedness (e.g., Kelly & Shin, 2009; Saunders et al., 2000). Similar to the results of the current study, Saunders et al. (2000) found that, although emotional and cognitive aspects were highly correlated and predicted significant variance in career decision status, independent variance was explained through only negative career thoughts, in addition to vocational identity. Additionally, the model proposed by Kelly and Shin (2009) demonstrated a similar relationship between career thoughts and career

indecision, although this study combined negative career thoughts and feelings to represent a single construct. Thus, the very high path coefficient between the latent variables of career-related thinking and career decision status replicates and extends prior research. Although this finding appears consistent with prior research, additional factors that may have influenced this result will be discussed further when examining potential limitations of the study.

Further, the observed variables used to measure career-related thoughts assessing the inability to initiate, sustain, or commit to a specific career choice (i.e., CTI-CA, CTI-DMC, CTI-EC) and confidence for completing career-related tasks (CDSE-SF) were correlated with observed endorsements of career indecision (i.e., CDS-IND), vocational interest (i.e., MVS-VI), and degree of commitment to a career (i.e., OAQ). The finding of a direct relationship between these variables is consistent with the assertion of Sampson et al. (2004). That is, the presence of negative thoughts is likely to lead an individual to require greater assistance in job search activities. Further, these findings are consistent with additional studies that have shown elevated negative thoughts and low self-efficacy to explain variance in and relate to difficulties in deciding upon a career (e.g., Kleiman et al., 2004; Saunders et al., 2000; Stead et al., 1993). Thus, negative thinking and difficulty making a career choice appear to be interrelated.

The third hypothesis stated that emotional distress and negative career-related thinking will be positively correlated with one another. As predicted, the latent variables of emotional distress and negative career-related thinking were found to be positively correlated ( $r = .49$ ). Additionally, the emotional distress observed variables assessing career tension (i.e., CTS), depression (i.e., DASS-D), stress (i.e., DASS-S), and anxiety

(i.e., DASS-A) were correlated with levels of the career-related thinking observed variables of negative thinking (i.e., CTI-CA, CTI-DMC, CTI-EC) and career decision-making self-efficacy (i.e., CDSE-SF). Prior research has also identified a correlation between emotional and cognitive constructs (e.g., Robbins, 1985; Saunders et al., 2000; Smith & Betz, 2002). As previously stated, both Kelly and Shin (2009) and Saunders et al. (2000) further identified the tendency of these latent variables to covary, as well as the usefulness of these constructs together in the explanation of career indecision. Therefore, the results of the current study support the existence of the finding that emotions and career-related thoughts, when examined in the realm of career decision making, are closely related. Individuals experiencing negative thoughts when making career-related decisions are also likely to possess negative emotions.

Therefore, the results of this study provided some support of a proposed model of career decidedness based on this cognitive-behavioral structure. The proposed model was supported through the relationships demonstrated between career-related thoughts, emotional distress, and career decision status. These results indicated the role of emotional distress and career thinking in the prediction of one's level of decidedness in regard to their vocational goals. These findings align with previous research, which has shown that individuals with low career decision-making self-efficacy and high anxiety levels have been shown to delay making a career decision (Betz & Vuyten, 1997; Fuqua et al., 1988). Additionally, previous research has supported that negative career thoughts and feelings predicted lack of information (Kelly & Shin, 2009), a large component of career decision status.

However, the results indicated a very strong relationship between the latent variables of career-related thoughts and career decision status as well as a non-significant relationship between the latent variables of emotional distress and career decision status. Thus, it appears that the measurement of career decision status may have had more cognitive related components or may have been influenced more through the presence of career-related thoughts. Therefore, although observed variables of emotional distress and career decision status were correlated, career-related thoughts appear to be a better predictor of an individual's level of decidedness.

#### Research Question 2

In addition to the creation of a model based on previous findings and theoretical underpinnings, the fit of this model to diverse individuals was examined to answer the second research question. That is, do diverse individuals differ in the best fitting model between these variables of interest? Specifically, analyses were conducted examining the fit of the model according to gender, race, and college class standing.

In a response to discrepant literature and to answer the research question, three hypotheses were examined. The first corresponding hypothesis stated that men and women will not differ in either the measurement or proposed model. Similarly, the second hypothesis read that African American and European American participants will not differ in either the measurement or proposed model. Thirdly, lower classmen and upper classmen will not differ in either the measurement or proposed model. Invariance testing provided support for each of the above hypotheses. When factor loadings were allowed to vary, they did not differ significantly from when they were constrained. Thus,

chi-square difference testing provided support for the use of this model with each of these diverse groups.

Previous research has been mixed with regards to career decision-making process differences among diverse groups. The current results contradict numerous studies that have found differences between groups on both variables used in the study, as well as models of career decision status. For example, Betz and Vuyten (1997) found no differences between men and women on any specific measure, including career decision-making self-efficacy, but found that career efficacy was more highly related to outcome expectations for men than women. Additionally, Creed et al. (2004) identified different best fitting models for men and women when cognitive style, internal (i.e., self-esteem), and external barriers were examined in the prediction of career indecision. In regard to race, Hammond et al. (2010) found that a model of career indecision (i.e., negative affect, low vocational identity development, lack of career information) that fit a sample involving mainly European American individuals did not fit as well as a modified model involving the predictors of emotion in addition to negative affectivity and information needs in a sample of African Americans. Further, differences between races have also been found when examining career barriers, finding that African American women perceived greater barriers than European American women (Lopez & Ann-Yi, 2006).

Yet, these findings also provide further support for the similarity of demographically diverse individuals in the career decision-making process. In contrast to the findings of Betz and Vuyten (1997) and Creed et al. (2004) and consistent with the results of the current study, Kelly and Shin (2009) found men and women did not differ in best fitting models explaining lack of information, a large component of career

indecision. Similarly, Saunders et al. (2000) found that, although men and women differed in the level of significance of paths, fit statistics revealed that men and women were equally well fit to a model of efficacy and esteem variables to depressive symptoms through their relationship to career indecision and shyness.

The results also converge with the findings of Tokar et al. (2000) in regard to lack of difference between undergraduate students across the years. Specifically, Tokar et al. (2000) found that individuals 21 years and younger did not differ meaningfully from those over 21 in the relationships of several variables (i.e., psychological separation, attachment security, vocational self-concept, crystallization) to the construct of career indecision.

Results of the study included the findings that differences did not exist between men and women, African Americans and European Americans, or upper and lower classmen. Thus, the results of the study provide support that the current model of career decision status fits equally well across gender, race, and college class standing in a sample of college undergraduates. These findings provide further clarification to discrepant findings in similar studies. As stated, prior research has indicated mixed results in regard to best fitting models for these groups. Additionally, inconsistent results have been found in regard to these groups on individual measures used to assess the variables of interest (e.g., Betz, Klein et al., 1996; Chaney et al., 2007; Gloria & Hird, 1999), which were not upheld in the current study. Therefore, the present study sought to address these discrepant results when examining a new model of career decision status and found that no such differences existed between groups in the proposed model.



### Clinical Implications

The findings of the study provide insight into factors that influence an individual's level of career decidedness. The theoretical underpinnings of cognitive-behavioral theory were used in conceptualization and validation of the present model by providing empirical support for a model involving cognitive and emotional factors and the resulting behavioral state of career decidedness. The study provided stronger support for the influence of career thoughts in predicting career decision status. Thus, level of negative thoughts appears to be highly influential in where an individual falls between completely decided and completely undecided.

Being aware of the types of relationships among cognitive and affective components on one's level of career decision status has several implications for clinicians. The findings of this study provide further information about the relationships among career variables and particularly the influence of negative thoughts.

The results provide further support for utilizing methods aimed at altering one's cognitions. Clinicians working with individuals presenting with career-related difficulties (e.g., indecision, undecided) can utilize methods shown to increase career decision-making self-efficacy and lower dysfunctional career thinking, constructs and observed variables used to assess career-related thinking, as measured in the current study. Addressing these negative thoughts prior to or during career exploration would be beneficial. Specifically, the four sources of self-efficacy and career courses targeting negative career thoughts have shown utility.

Within the context of this study's results, Social Cognitive Career Theory (SCCT; Lent et al., 1994) and the Cognitive Information Processing (CIP) approach to decision

making (Sampson et al., 2004) provide guidance to counselors. As previously stated, SCCT emphasizes the role of cognitive components (i.e., self-efficacy beliefs, outcome expectations, personal goals) in the areas of development in education and vocation, choice, and performance. The SCCT model describes how individuals decide upon academic majors and aspire toward particular career paths through looking at the interaction of self-efficacy beliefs, outcome expectations, and personal goals. Thus, these three constructs within the context of the individual are useful in predicting occupational interests, choices, and performance.

Self-efficacy is an important predictor of career-related behavior in the SCCT theory and was found to be related to and predict the level of career decidedness in the current study. An individual's perceptions of his or her capabilities are developed and modified through four sources. The four sources of self-efficacy (i.e., performance accomplishments, vicarious learning, emotional arousal, verbal persuasion) have been shown to increase one's confidence in completing tasks needed for making a career decision (e.g., Luzzo & Day, 1999; Luzzo et al., 1996; Luzzo & Taylor, 1993; Sullivan & Mahalik, 2000). For example, research has supported the use of verbal persuasion, a method by which persuasive messages are utilized, to increase career decision-making self-efficacy (Luzzo & Taylor, 1993).

Additionally, assessing one's level of self-efficacy beliefs can further provide clinicians with important information. Low levels of self-efficacy have been related to avoidance behaviors, while approach behaviors are associated with higher expectations. Individuals believing in their capability to engage in tasks necessary to making a career decision are more likely to partake in these behaviors, as well as choose or commit to a

high or difficult goal. Thus, evaluating one's level of career decision-making self-efficacy can additionally serve to inform clinicians of the manner in which these individuals may engage in treatment. For example, those with higher levels of career decision-making self-efficacy may take to directives to search out information and complete tasks on their own, whereas those with lower confidence may need more assistance and more concrete assignments.

The CIP approach emphasizes both cognitive and affective components as influencing an individual's decision-making process (Sampson et al., 2004). Interventions utilizing the CIP approach focus on discovering and disrupting one's negative thoughts, as well as engaging strategies for coping with complex decision-making strategies. Two key components comprise the CIP approach: the pyramid of information processing domains and a decision-making process. The pyramid of information processing includes self and options knowledge, decision-making skills, and executive processing domains. The CASVE cycle, a multi-phase decision-making process, comprises the decision-making skills domain and encompasses the phases of Communication, Analysis, Synthesis, Valuing, and Execution. The executive processing domain includes metacognitions, or beliefs about one's own thoughts, which manage the selection and sequencing of cognitions involved in career decision making. The CTI was developed to assess the executive processing domain by the CIP theorists, and the subscales were three of the observed variables used to assess career-related thinking. Negative thoughts are viewed as affecting all other components involved in making a good decision, including the evaluation of oneself and the world of work, as well as the individual steps involved in making a decision. Thus, using cognitive restructuring

techniques to identify, challenge, and alter negative career thoughts that may be impeding flow of adaptive self and options knowledge, as well as affecting confidence in one's ability to complete necessary tasks may be useful in aiding clients in progressing effectively through the CASVE cycle and making effective career decisions.

In addition to methods consistent with SCCT, career counseling targeting the metacognitions domain of the CIP approach can be used to reduce an individual's level and types of negative career thoughts. Metacognitions include self-talk, self-awareness, and control and monitoring. Self-awareness includes awareness of one's self while making decisions. Monitoring and control refers to the ability to monitor where one is in the problem solving process, as well as to control the amount of attention and information needed. Self-talk includes positive or negative thoughts regarding the career process and may include statements such as "I'll never be able to make a good career choice." As metacognitions have been shown to affect both the decision-making process and knowledge domains, by assessing and addressing negative career thoughts clinicians can aid clients in increasing effective decision making.

Additionally, college courses addressing career development have shown reductions in college students' negative career-related thinking (e.g., Osborn, Howard, & Leierer, 2007; Reed, Reardon, Lenz, & Leierer, 2001). Osborn et al. (2007) described the courses as involving explanation of the world of work, identifying and reframing negative thoughts, introduction to theories of career development and decision-making skills, identification of personal knowledge, introduction to career exploration resources, relating personal characteristics and goals to academic majors, and creation of an individualized action plan over a six-week period. Both Reed et al. (2001) and Osborn et

al. (2007) found that individuals with the highest level of negative career-related thinking demonstrated the greatest decrease. Therefore, the use of career courses utilizing methods consistent with the CIP approach and targeting metacognitions might be an efficient and effective method to reduce negative thoughts for large groups of students. The results of the current study support that the use of previously demonstrated methods for altering negative career thinking and career decision-making self-efficacy can be enacted for individuals presenting as undecided or having similar career difficulties.

Further, the CIP approach also provides information regarding an individual's readiness to progress through the career decision-making process. Readiness takes into account both the individual's capability to perform the tasks, as well as the complexity of the individual's current situation. According to the CIP approach, the presence of a high level of negative thinking may lower one's capability and, therefore, readiness to make a career-related decision. Thus, the evaluation of level of negative career thoughts can be beneficial in determining an individual's readiness to engage in the process of choosing a career, as well as indicating the level of career assistance needed. That is, individuals with high levels of negative thinking are likely to require greater assistance in the career decision-making process (Sampson et al., 2004). Further, the methods described previously (e.g., career courses) may be best tailored to individuals by taking into account the number and types of negative career thoughts present. For example, individuals with higher readiness may find career courses to be beneficial, while those with lower readiness may require more individualized methods.

Further, although a direct relationship between the latent variables of emotional distress and career decision status did not prove to be significant, the individual

emotional and career decision status observed variables correlated highly in the present study. Thus, the current study, as well as prior literature (e.g., Campagna & Curtis, 2007; Fuqua et al., 1988), indicates the emotional aspects associated with level of career decidedness. The exact nature of the role of emotional distress in making a career-related decision is not completely understood. Saunders et al. (2000) asserted that negative affective states may be a result of a weak vocational identity and negative thinking may exacerbate career difficulties by decreasing one's ability to process adaptive information when making a career decision. Although the role of emotional stress is not as clear, the literature and the current study do support intercorrelations with both cognitive components, as well as career decision status. Therefore, the identification of symptoms of affective difficulties likely to impede effective career decision making (e.g., depression, anxiety, career tension) should be assessed when clients present with career indecision. The assessment of these emotional aspects may aid practitioners in determining how to best assist the client. For example, those presenting with high levels of anxiety or depression may be best served by the practitioner addressing the affective difficulties prior to integrating career decision making.

The study additionally provided support of the utility of this model across diverse demographic groups. The model fit equally well across groups of participants identifying as men and women, African American and European American, and lower- and upperclassmen. Therefore, the findings regarding the influence of emotional and cognitive aspects on one another, as well as on one's level of decision regarding a major or career, can be upheld across each of these groups. Thus, clinicians and instructors can

feel confident to utilize similar approaches across these demographic groups in approaching career-related difficulties.

### Limitations and Future Research Directions

Although this study produces a model of career decidedness stemming from previous research and theoretical orientations, the present study should be examined with regards to its limitations. Additionally, the limitations of the study guide directions for future research. A limitation of the study is the small sample of men recruited ( $n = 43$ ). Previous studies with similar unequal distributions of men and women (e.g., Ham, Zamboanga, Bacon, & Garcia, 2009; Smith & Betz, 2002) have also employed multigroup analyses and made assertions based on their findings of the implications of these results. Although the overall sample size was sufficient to conduct multigroup analysis (e.g., Iacobucci, 2010; Tabachnick & Fidell, 2007) and results indicated no significant differences between men and women in the current study, future studies may benefit from recruiting a larger sample of men to see if this finding is upheld. Therefore, caution should be used when generalizing these findings to men, and further research including a larger male sample would be helpful in determining if the proposed model is the best fitting model for men as well. Therefore, future research should aim at collecting a greater number of men to provide further support for the model with a male population.

An additional limitation of the current study is the use of a single sample in the testing of the model, especially since this sample was found to be largely decided, satisfied, and reported little distress or negative thinking. Therefore, a further area of study includes the recruitment of an additional independent sample to replicate the fit of

the model. Replication of these results is particularly important to address some of the already stated limitations, including unequal demographic distribution. Through recruitment of a more diverse sample, the fit of this model can be verified and further explored with respect to diverse groups, including men, other ethnic groups, and non-college populations.

Further research and testing of additional measures of the latent variables may be helpful to examine in strengthening the fit of the data to each of the latent variables (i.e., emotional distress, career-related thinking, career decision status). The measures and scales utilized provided adequate fit to their individual latent variables and good support when examined within the model as a whole; however, whether additional or different measures would provide stronger support for the constructs is unknown. For example, the results of this study further provide support for the interrelatedness of cognitive and affective components. Identifying and utilizing measures that more clearly separate these components may provide a more effective means of testing this model, as well as providing support for any directional relationships between career thinking and emotional distress. Further, the measures used were all self-report in nature. Including measures that involve more concrete behavioral indicators of career indecision (e.g., instructor ratings, academic advisor ratings, steps taken in meeting career goals) instead of self-report may further provide stronger support for the fit of this model.

Additionally, the results of this study provided stronger support for career-related thinking in predicting career decision status than emotional distress. This finding does not fit well with prior research that has supported both emotional and cognitive components in the prediction of career decision status. Therefore, a potential limitation



of the study may be the inability of the measures that were used to assess each of the constructs exclusively. Prior research has cited the overlap of cognitive and affective components in similar studies and in the measurement of career indecision as difficulties in separating these constructs out from one another. Cognitive and affective components may not have been exclusively assessed by the measures used. Further, measures used to assess career decision status may have assessed for more cognitive aspects of decidedness, thereby increasing this relationship between career decision status and career-related thinking.

Due to the stated difficulties separating cognitive and affective components in prior literatures as well as this study identifying a non-significant relationship between the latent variables of emotional distress and career decision status, the use of different measures to assess the constructs in the study in an attempt to better separate cognitive and affective constructs may be warranted. Other measures that may be considered in the assessment of career thoughts are the Career Myths Scale (Stead, 1991), Career Beliefs Inventory (Krumboltz, 1994), Career Decision-Making Difficulties Questionnaire Dysfunctional Beliefs subscale (Gati, Krausz, & Osipow, 1996), and the Adult Career Concerns Inventory (Super, Thompson, & Lindeman, 1988). Mau (2001) asserted the use of the Career Beliefs Inventory in addition to two of the measures used in the current study, CDSE-SF and CTI, to provide further information into the role of career thinking. For assessing emotions, the Career Decision-Making Difficulties Questionnaire Internal Conflict subscale (Gati et al., 1996), Occupational Stress Inventory (Osipow & Spokane, 1987), and the Occupational Crisis Scale (Hutri, 1995). As for assessing career decision status, exploration intentions as measured by the Career Decision Making Outcome

Expectancies and Exploratory Intentions (Betz & Vuyten, 1997) or by assessing actual behaviors regarding steps individuals have taken in pursuing one's intended career may be beneficial in providing a more concrete definition of one's behaviors, as well as removing the possible influence of thoughts that may have been present in the current study by asking participants about the future and difficulties that are encountered due to lack of self-confidence or negative beliefs (e.g., "I am not sure of myself in many areas of life," "I can't make a career choice right now because I don't know what my abilities are"). The testing of this model using this or other varied measures may provide further information on the relationship among these variables, as well as provide support for measures that may better separate cognitive and affective components.

#### Summary

The present study resulted in the creation of a new model of career decision status based in a cognitive-behavioral model framework. This study built upon previous career development literature connecting various related constructs to the outcome of career decidedness and expanded this relationship through the introduction of a guiding cognitive-behavioral theoretical perspective. The model separated career thinking and emotional distress and used a range of measures to assess each of these constructs. The current study found that career-related thinking and emotional distress were related to one another and that cognitions explained career decision status. However, career-related thoughts, defined by career decision-making self-efficacy and dysfunctional career thoughts, appear to be the greatest predictor and possibly the same construct as career decision status. Additionally, differences did not exist in the best fitting model for men and women, African American and European American, or under- and upper-classmen

participants. These findings support the use of suggested interventions for various groups of college students. The results build upon and extend prior literature demonstrating the relationships among career decision status and numerous other constructs. This study, in addition to previous literature, indicates the importance of cognitive and affective components in college students' career decision status.

APPENDIX A  
IRB APPROVAL



THE UNIVERSITY OF  
SOUTHERN MISSISSIPPI.

INSTITUTIONAL REVIEW BOARD  
118 College Drive #5147 | Hattiesburg, MS 39406-0001  
Phone: 601.266.6820 | Fax: 601.266.4377 | www.usm.edu/irb

**NOTICE OF COMMITTEE ACTION**

The project has been reviewed by The University of Southern Mississippi Institutional Review Board in accordance with Federal Drug Administration regulations (21 CFR 26, 111), Department of Health and Human Services (45 CFR Part 46), and university guidelines to ensure adherence to the following criteria:

- The risks to subjects are minimized.
- The risks to subjects are reasonable in relation to the anticipated benefits.
- The selection of subjects is equitable.
- Informed consent is adequate and appropriately documented.
- Where appropriate, the research plan makes adequate provisions for monitoring the data collected to ensure the safety of the subjects.
- Where appropriate, there are adequate provisions to protect the privacy of subjects and to maintain the confidentiality of all data.
- Appropriate additional safeguards have been included to protect vulnerable subjects.
- Any unanticipated, serious, or continuing problems encountered regarding risks to subjects must be reported immediately, but not later than 10 days following the event. This should be reported to the IRB Office via the "Adverse Effect Report Form".
- If approved, the maximum period of approval is limited to twelve months. Projects that exceed this period must submit an application for renewal or continuation.

PROTOCOL NUMBER: **11081803**  
 PROJECT TITLE: **Career Decision Status, Career-Related Thinking, and Emotional Distress: A Structural Equation Model**  
 PROJECT TYPE: **Dissertation**  
 RESEARCHER/S: **Lindsay Andrews**  
 COLLEGE/DIVISION: **College of Education & Psychology**  
 DEPARTMENT: **Counseling Psychology**  
 FUNDING AGENCY: **N/A**  
 IRB COMMITTEE ACTION: **Expedited Review Approval**  
 PERIOD OF PROJECT APPROVAL: **08/29/2011 to 08/28/2012**

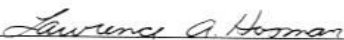
  
 \_\_\_\_\_  
 Lawrence A. Hosman, Ph.D.  
 Institutional Review Board Chair

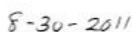
  
 \_\_\_\_\_  
 Date

## APPENDIX B

## INFORMED CONSENT

**The University of Southern Mississippi  
Authorization to Participate in Research Project**

Consent is hereby given to participate in the study titled: *Career Decision Status, Career-Related Thinking, and Emotional Distress*.

**Purpose:** The purpose of this study is to evaluate career development of college students through examining multiple career variables.

**Description of Study:** Participant in this study will be asked to complete several questionnaires that assess thinking, emotional experiences, and confidence in relation to career development. All questionnaires completed will be done so anonymously and all responses will be kept confidential. All resulting data will be combined, all identifying information will be removed, and the data will be entered into a computer database program and appropriately analyzed. This process does not incorporate any invasive procedures.

**Benefits:** Potential benefits of this research include a better understanding of the variables affecting adult career development and the potential of class credit if applicable to you.

**Risks:** This is a minimal risk study that does not ask significantly personal questions and as a result there do not appear to be any major risks related to completing the questionnaire. Participants can discontinue from further participation in the study at any time without consequence. Further, participants can contact the principle investigator of this study, Lindsay Andrews, at any time throughout the study. If you are interested in seeking career assistance, USM makes career assistance available to you through USM Career Services: McLemore Hall, Room 125; Phone: 601-266-4153; Email: [cpp@usm.edu](mailto:cpp@usm.edu).

**Confidentiality:** This is an online survey and only researchers will have access to the information provided. Information related to the questionnaires will be stored in a locked room located in the Department of Psychology at The University of Southern Mississippi. Information from these questionnaires will be entered into a computer database, will be combined, and will no longer be connected to a participant's name after completion of the forms.

**Alternative procedures:** Any participant may discontinue participation in this study at any time without consequence. If you are seeking class credit through your participation in this study, please refer to your course instructor for alternatives to participating in this research project.

**Participant's assurance:** Assurances cannot be made concerning results that may be obtained (since results from investigational studies cannot be predicted). Yet, the researcher will take every precaution consistent with the best scientific practice. Participation in this project is completely voluntary, and participants may withdraw from this study at any time without penalty, prejudice, or loss of benefits. Questions concerning the research should be directed to Lindsay Andrews at [Lindsay.Andrews@eagles.usm.edu](mailto:Lindsay.Andrews@eagles.usm.edu) or Emily Yowell, Ph.D. at (601) 266-6603 or [Emily.Yowell@usm.edu](mailto:Emily.Yowell@usm.edu). This project and this consent form have been reviewed by the Institutional Review Board, which ensures that research projects involving human subjects follow federal regulations. Any questions or concerns about rights as a research subject should be directed to the Chair of the Institutional Review Board, The University of Southern Mississippi, 118 College Drive #5147, Hattiesburg, MS 39406-0001, (601) 266-6820.

## REFERENCES

- Antony, M. M., Bieling, P. J., Cox, B. J., Enns, M. W., & Swinson, R. P. (1998). Psychometric properties of the 42-item and 21-item versions of the Depression Anxiety Stress scales in clinical groups and a community sample. *Psychological Assessment, 10*, 176-181. doi:10.1037//1040-3590.10.2.176
- Bandura, A. (1977). Self-efficacy: Toward a unifying theory of behavioral change. *Psychological Review, 84*, 191-215. doi:10.1037/0033-295X.84.2.191
- Bandura, A. (1986). *Social foundations of thought and action: A social-cognitive theory*. Englewood Cliffs, NJ: Prentice-Hall.
- Beck, A. T. (1972). *Depression: Causes and treatment*. Philadelphia, PA: University of Pennsylvania Press.
- Beck, A. T. (1987). Cognitive approaches to panic disorder: Theory and therapy. In S. Rachman, & J. Maser (Eds.), *Panic: Psychological perspectives* (pp. 91-109). Hillsdale, NJ: Erlbaum.
- Beck, J. S. (1995). *Cognitive therapy: Basics and beyond*. New York, NY: The Guilford Press.
- Betz, N. E., & Hackett, G. (1981). The relationship of career-related self-efficacy expectations to perceived career options in college women and men. *Journal of Counseling Psychology, 28*, 399-410. doi:10.1037//0022-0167.28.5.399
- Betz, N. E., & Hackett, G. (1983). The relationship of mathematics self-efficacy expectations to the selection of science-based college majors. *Journal of Vocational Behavior, 23*, 329-345. doi:10.1016/0001-8791(83)90046-5

- Betz, N. E., Harmon, L. W., & Borgen, F. H. (1996). The relationships of self-efficacy for the Holland themes to gender, occupational group membership, and vocational interests. *Journal of Counseling Psychology, 43*, 90-98. doi:10.1037//0022-0167.43.1.90
- Betz, N. E., Klein, K. L., & Taylor, K. M. (1996). Evaluation of a short form of the Career Decision-Making Self-Efficacy Scale. *Journal of Career Assessment, 4*, 47-57. doi:10.1177/106907279600400103
- Betz, N. E., & Luzzo, D. A. (1996). Career assessment and the Career Decision-Making Self-Efficacy Scale. *Journal of Career Assessment, 4*, 413-428. doi:10.1177/106907279600400405
- Betz, N. E., & Sterling, D. (1993). Criterion-related and construct validity of fear of commitment. *Journal of Career Assessment, 1*, 21-34. doi:10.1177/106907279300100104
- Betz, N. E., & Voyten, K. K. (1997). Efficacy and outcome expectations influence career exploration and decidedness. *The Career Development Quarterly, 46*, 179-189. doi:10.1002/j.2161-0045.1997.tb01004.x
- Brown, T. A., Chorpita, B. F., Korotitsch, W., & Barlow, D. H. (1997). Psychometric properties of the Depression Anxiety Stress Scales (DASS) in clinical samples. *Behaviour Research and Therapy, 35*, 79-89. doi:10.1016/S0005-7967(96)00068-X
- Brown, S. D., & Ryan Krane, N. E. (2000). Four (or five) sessions and a cloud of dust: Old assumptions and new observations about career counseling. In S. D. Brown,

& R. W. Lent (Eds.), *Handbook of counseling psychology* (3<sup>rd</sup> ed., pp. 740-766).  
New York, NY: Wiley.

Bullock, E. E., Peterson, G. W., Reardon, R. C., Leierer, S. J., & Reed, C. A. (in press).  
Relationships among career and life stress, negative career thoughts, and career  
decision state: A cognitive information processing perspective. *The Career  
Development Quarterly*.

Bullock-Yowell, E., Andrews, L., & Buzzetta, M. E. (2011). Explaining career decision-  
making self-efficacy: Personality, cognitions, and cultural mistrust. *The Career  
Development Quarterly*, 59(5), 400-411.

Campagna, C. G., & Curtis, G. J. (2007). So worried I don't know what to be: Anxiety  
is associated with increase career indecision and reduced career certainty.  
*Australian Journal of Guidance & Counselling*, 17, 91-96.  
doi:10.1375/ajgc.17.1.91

Chaney, D., Hammond, M. S., Betz, N. E., & Multon, K. D. (2007). The reliability and  
factor structure of the Career Decision Self-Efficacy Scale-SF with African  
Americans. *Journal of Career Assessment*, 15, 194-205.  
doi:10.1177/1069072706298020

Chartrand, J. M., Rose, M. L., Elliott, T. R., Marmarosh, C., & Caldwell, S. (1993).  
Peeling back the onion: Personality, problem solving, and career decision-making  
style correlates of career indecision. *Journal of Career Assessment*, 1, 66-82.  
doi:10.1177/106907279300100107



- Cheung, G. W., & Rensvold, R. B. (2002). Evaluating goodness-of-fit indexes for testing measurement invariance. *Structural Equation Modeling, 9*, 233-255.  
doi:10.1207/S15328007SEM0902\_5
- Chung, Y. B. (2002). Career decision-making self-efficacy and career commitment: Gender and ethnic difference among college students. *Journal of Career Development, 28*(4), 277-284.
- Cohen, C. R., Chartrand, J. M., & Jowdy, D. P. (1995). Relationships between career indecision subtypes and ego identity development. *Journal of Counseling Psychology, 42*, 440-447. doi:10.1037//0022-0167.42.4.440
- Costa, P. T., Jr., & McCrae, R. R. (1992). *The NEO Personality Inventory (NEO PI-R) and NEO Five-Factor Inventory (NEO-FFI) professional manual*. Odessa, FL: Psychological Assessment Resources.
- Creed, P. A., Patton, W., & Bartrum, D. (2002). Multidimensional properties of the LOT-R: Effects of optimism and pessimism on career and well-being related variables in adolescents. *Journal of Career Assessment, 10*, 42-61.  
doi:10.1177/1069072702010001003
- Creed, P. A., Patton, W., & Bartrum, D. (2004). Internal and external barriers, cognitive style, and the career development variables of focus and indecision. *Journal of Career Development, 30*, 277-294. doi: 10.1177/089484530403000404
- Creed, P., Patton, W., & Prideaux, L. (2006). Causal relationship between career indecision and career decision-making self-efficacy: A longitudinal cross-lagged analysis. *Journal of Career Development, 33*, 47-65.  
doi:10.1177/0894845306289535

- Crites, J. O. (1969). *Vocational psychology*. New York, NY: McGraw-Hill.
- Ellis, A. (1962). *Reason and emotion in psychotherapy*. Oxford, UK: Lyle Stuart.
- Farmer, H. S. (1976). What inhibits achievement and career motivation in women? *The Counseling Psychologist*, 6, 12-14. doi:10.1177/001100007600600204
- Felsman, D. E., & Blustein, D. L. (1999). The role of peer relatedness in late adolescent career development. *Journal of Vocational Behavior*, 54, 279-295.  
doi:10.1006/jvbe.1998.1664
- Fuqua, D. R., Newman, J. L., & Seqworth, T. B. (1988). Relation of state and trait anxiety to different components of career indecision. *Journal of Counseling Psychology*, 35, 154-158. doi:10.1037//0022-0167.35.2.154
- Gaffner, D. C., & Hazler, R. J. (2002). Factors related to indecisiveness and career indecision in undecided college students. *Journal of College Student Development*, 43(3), 317-326.
- Gati, I., Krausz, M., & Osipow, S. H. (1996). A taxonomy of difficulties in career decision-making. *Journal of Counseling Psychology*, 43, 510-526.  
doi:10.1037//0022-0167.43.4.510
- Gati, I., & Saka, N. (2001). High school students' career-related decision-making difficulties. *Journal of Counseling and Development*, 79(3), 331-340.
- Germeijs, V., & de Boeck, P. (2003). Career indecision: Three factors from decision theory. *Journal of Vocational Behavior*, 62, 11-25. doi:10.1016/S0001-8791(02)00055-6
- Gianakos, I. (1999). Patterns of career choice and career decision-making self-efficacy. *Journal of Vocational Behavior*, 54, 244-258. doi:10.1006/jvbe.1998.1668

- Gloria, A. M., & Hird, J. S. (1999). Influences of ethnic and nonethnic variables on the career decision-making self-efficacy of college students. *The Career Development Quarterly*, 48(2), 157-174.
- Goodstein, L. D. (1965). Behavior theoretical views of counseling. In B. Stefflre (Ed.), *Theories of counseling*. New York, NY: McGraw-Hill.
- Gordon, V. N. (2007). *The undecided college student: An academic and career advising challenge* (3<sup>rd</sup> ed. ). Springfield, IL: Charles C. Thomas.
- Gordon, L., & Meyer, J. C. (2002). Career indecision amongst prospective university students. *South African Journal of Psychology*, 32(4), 41-47.
- Gottfredson, L. S. (2005). Applying Gottfredson's theory of circumscription and compromise in career guidance and counseling. In S. D. Brown & R. W. Lent (Eds.), *Career development and counseling: Putting theory and research to work* (pp. 71-99). New York, NY: Wiley.
- Guay, F., Senecal, C., Gauthier, L., & Fernet, C. (2003). Predicting career indecision: A self-determination theory perspective. *Journal of Counseling Psychology*, 50, 165-177. doi:10.1037/0022-0167.50.2.165
- Guerra, A. L., & Braumgart-Rieker, J. M. (1999). Predicting career indecision in college students: The roles of identity formation and parental relationship factors. *The Career Development Quarterly*, 47(3), 255-266.
- Hackett, G., & Betz, N. E. (1981). A self-efficacy approach to the career development of women. *Journal of Vocational Behavior*, 18, 326-339. doi:10.1016/0001-8791(81)90019-1

- Ham, L. S., Zamboanga, B. L., Bacon, A. K., & Garcia, T. A. (2009). Drinking motives as mediators of social anxiety and hazardous drinking among college students. *Cognitive Behaviour Therapy, 38*, 133-145. doi:10.1080/16506070802610889
- Hammond, M.S., Lockman, J.D., & Boling, T. (2010). A test of the tripartite model of career indecision of Brown and Krane for African Americans incorporating emotional intelligence and positive affect. *Journal of Career Assessment, 18*, 161-176. doi:10.1177/1069072709354201
- Harmon, L. W. (1977). Career counseling for women. In E. Rawlings & D. Carter (Eds.). *Psychotherapy for women* (pp. 308-316). Springfield, IL: Thomas.
- Hartman, R., & Betz, N. E. (2007). The five factor model and career self-efficacy. *Journal of Career Assessment, 15*, 145-161. doi:10.1177/1069072706298011
- Hartman, B., Fuqua, D., & Hartman, P. (1983). The construct validity of the Career Decision Scale administered to high school students. *Vocational Guidance Quarterly, 31*(4), 250-258.
- Hawkins, J. G., Bradley, R. W., & White, G. W. (1977). Anxiety and the process of deciding about a major and vocation. *Journal of Counseling Psychology, 24*, 398-403. doi:10.1037//0022-0167.24.5.398
- Holland, J. L., Daiger, D. C., & Power, P. G. (1980). *My Vocational Situation*. Palo Alto, CA: Consulting Psychologists Press.
- Holland, J. L., & Holland, J. E. (1977). Vocational indecision: More evidence and speculation. *Journal of Counseling Psychology, 24*, 404-414. doi:10.1037//0022-0167.24.5.404

- Holland, J. L., Johnston, J. A., & Asama, N. F. (1993). The Vocational Identity Scale: A diagnostic and treatment tool. *Journal of Career Assessment, 1*, 1-12.  
doi:10.1177/106907279300100102
- House, R. J., & Rizzo, J. R. (1972). Toward the measurement of organizational practices: Scale development and validation. *Journal of Applied Psychology, 56*, 388-396.  
doi:10.1037/h0033444
- Hutri, M. (1995). The role of work-related causal attributions in occupational crisis. *Journal of Psychology, 129*, 167-180. doi:10.1080/00223980.1995.9914956
- Hutri, M., & Lindeman, M. (2002). The role of stress and negative emotions in an occupational crisis. *Journal of Career Development, 29*(1), 19-36.
- Iacobucci, D. (2010). Structural equations modeling: Fit indices, sample size, and advanced topics. *Journal of Consumer Psychology, 20*, 90-98.  
doi:10.1016/j.jcps.2009.09.003
- Jones, L. K., & Chenery, M. F. (1980). Multiple subtypes among vocationally undecided college students: A model and assessment instrument. *Journal of Counseling Psychology, 27*, 469-477. doi:10.1037/0022-0167.27.5.469
- Kaplan, D. M., & Brown, D. (1987). The role of anxiety in career indecisiveness. *Career Development Quarterly, 36*(2), 148-162.
- Kelly, K. R., & Pulver, C. A. (2002). Refining measurement of career indecision types: A validity study. *Journal of Counseling and Development, 81*(4), 445-454.
- Kelly, K. R., & Shin, Y. (2009). Relation of neuroticism and negative career thoughts and feelings to lack of information. *Journal of Career Assessment, 17*, 201-213.  
doi:10.1177/1069072708329029

- Kimes, H. G., & Troth, W. A. (1974). Relationship of trait anxiety to career decisiveness. *Journal of Counseling Psychology, 21*, 277-280.  
doi:10.1037/h0037611
- Kleiman, T., Gati, I., Peterson, G., Sampson, J., Reardon, R., & Lenz, J. (2004). Dysfunctional thinking and difficulties in career decision making. *Journal of Career Assessment, 12*, 213-331. doi:10.1177/1069072704266673
- Krumboltz, J. D. (1994). The Career Beliefs Inventory. *Journal of Counseling and Development, 72*(4), 424-428.
- Krumboltz, J. D., Mitchell, A. M., & Jones, G. B. (1976). A social learning theory of career selection. *The Counseling Psychologist, 6*, 71-80.  
doi:10.1177/001100007600600117
- Larson, K. M., Heppner, P. P., Ham, T., & Dugan, K. (1988). Investigating multiple subtypes of career indecision through cluster analysis. *Journal of Counseling Psychology, 35*, 439-446. doi:10.1037//0022-0167.35.4.439
- Lent, R. W., Brown, S. D., & Hackett, G. (1994). Toward a unifying social cognitive theory of career and academic interest, choice, and performance [Monograph]. *Journal of Vocational Behavior, 45*, 79-122. doi:10.1006/jvbe.1994.1027
- Leong, F. T. L., & Chervinko, S. (1996). Construct validity of career indecision: Negative personality traits as predictors of career indecision. *Journal of Career Assessment, 4*, 315-329. doi:10.1177/1069072704266673
- Lopez, F. G., & Ann-Yi, S. (2006). Predictors of career indecision in three racial/ethnic groups of college women. *Journal of Career Development, 33*, 29-46.  
doi:10.1177/0894845306287341

- Lounsbury, J. W., Tatum, H. E., Chambers, W., Owens, K. S., & Gibson, L. W. (1999). An investigation of career decidedness in relation to Big Five personality constructs and life satisfaction. *College Student Journal, 33*(4), 646-652.
- Lovibond, S. H., & Lovibond, P. F. (1995). *Manual for the Depression Anxiety Stress Scales* (2nd ed.). Sydney, Australia: Psychology Foundation of Australia.
- Lucas, E. B., Gysbers, N. C., Buescher, K. L., & Heppner, P. P. (1988). My Vocational Situation: Normative, psychometric, and comparative data. *Measurement and Evaluation in Counseling and Development, 20*(4), 162-170.
- Luzzo, D. A., & Day, M. A. (1999). Effects of Strong Interest Inventory feedback on career decision-making self-efficacy and social cognitive career beliefs. *Journal of Career Assessment, 7*, 1-17. doi:10.1177/106907279900700101
- Luzzo, D. A., Funk, D. P., & Strang, J. (1996). Attributional retraining increases career decision-making self-efficacy. *Career Development Quarterly, 44*(4), 378-386.
- Luzzo, D. A., & Taylor, M. (1993). Effects of verbal persuasion on the career self-efficacy of college freshman. *California Association for Counseling and Development Journal, 14*(1), 31-34.
- Mau, W. C. (1995). Decision-making style as a predictor of career decision-making status and treatment gains. *Journal of Career Assessment, 3*, 89-99. doi:10.1177/106907279500300107
- Mau, W. C. (2001). Assessing career decision-making difficulties: A cross-cultural study. *Journal of Career Assessment, 9*, 353-364. doi:10.1177/106907270100900403

- Meichenbaum, D., & Cameron, R. (1982). Cognitive-behavior therapy. In G. T. Wilson & C. M. Franks (Eds.), *Contemporary behavior therapy: Conceptual and empirical foundations* (pp. 310-338). New York, NY: Guilford Press.
- Meyer, B.W., & Winer, J. L. (1993). The Career Decision Scale and neuroticism. *Journal of Career Assessment, 1*, 171-180. doi:10.1177/106907279300100206
- Multon, K. D., & Lapan, R. T. (1995). Developing scales to evaluate career and personal guidance curricula in a high school setting. *Journal of Career Development, 21*, 293-305. doi:10.1007/BF02106153
- Neimeyer, G. J., & Metzler, A. E. (1987). The development of vocational structures. *Journal of Vocational Behavior, 30*(1), 26-32.
- Nota, L., & Soresi, S. (2003). An assertiveness training program for indecisive students attending an Italian university. *Career Development Quarterly, 51*(4), 322-334.
- O'Leary, V. E. (1974). Some attitudinal barriers to occupational aspirations in women. *Psychological Bulletin, 81*, 809-826. doi:10.1037/h0037267
- Osborn, D. S., Howard, D. K., & Leierer, S. J. (2007). The effects of a career development course on the dysfunctional career thoughts of racially and ethnically diverse college freshmen. *The Career Development Quarterly, 55*(4), 365-377.
- Osipow, S. H. (1987). *Manual for the Career Decision Scale*. Odessa, FL: Psychological Assessment Resources.
- Osipow, S. H. (1999). Assessing career indecision. *Journal of Vocational Behavior, 55*, 147-154. doi:10.1006/jvbe.1999.1704



- Osipow, S. H., Carney, C. G., & Barak, A. (1976). A scale of education-vocational undecidedness: A typological approach. *Journal of Vocational Behavior*, 9, 233-243. doi:10.1016/0001-8791(76)90081-6
- Osipow, S. H., Carney, C. G., Winer, J. L., Yanico, B., & Koschier, M. (1987). *The Career Decision Scale (3rd rev.)*. Odessa, FL: Psychological Assessment Resources.
- Osipow, S. H., & Spokane, A. R. (1987). *Manual for the Occupational Stress Inventory*. Odessa, FL: Psychological Assessment Resources.
- Patton, W., & Creed, P. A. (2001). Developmental issue in career maturity and career decision status. *The Career Development Quarterly*, 49(3), 336-351.
- Patton, W., Creed, P. A., & Watson, M. (2003). Perceived work related and non-work related barriers in the career development of Australian and South African adolescents. *Australian Journal of Psychology*, 55, 74-82.  
doi:10.1080/00049530412331312924
- Peterson, G. W., Sampson, J. P., Jr., Reardon, R. C., & Lenz, J. G. (1996). Becoming career problem solvers and decision makers: A cognitive information processing approach. In D. Brown & L. Brooks (Eds.), *Career choice and development* (3rd ed., pp. 423-475). San Francisco, CA: Jossey-Bass.
- Reed, C. A. (2005). *The relationships among neuroticism, dysfunctional career thoughts, and coping strategies* (Doctoral dissertation, Florida State University). Retrieved from <http://etd.lib.fsu.edu/theses/available/etd-07032005-123327>

- Reed, C. A., Reardon, R. C., Lenz, J. G., & Leierer, S. J. (2001). A cognitive career course: From theory to practice. *The Career Development Quarterly, 50*(2), 158-167.
- Richman, D. R. (1993). Cognitive psychotherapy through the career cycle. In W. Dryden & P. Trower (Eds.), *Development in cognitive psychotherapy* (pp. 190-217). Thousand Oaks, CA: Sage Publications.
- Robbins, S. B. (1985). Validity estimates for the Career Decision Making Self-Efficacy Scale. *Measurement and Evaluation in Counseling and Development, 18*(2), 64-71.
- Rojewski, J. W. (1994). Career indecision types for rural adolescents from disadvantaged and nondisadvantaged backgrounds. *Journal of Counseling Psychology, 41*, 356-363. doi:10.1037/0022-0167.41.3.356
- Saka, N., & Gati, I. (2007). Emotional and personality-related aspects of persistent career decision-making difficulties. *Journal of Vocational Behavior, 71*, 340-358. doi:10.1016/j.jvb.2007.08.003
- Salomone, R. B. (1982). Difficult cases in career counseling: II – the indecisive client. *Personnel and Guidance Journal, 60*(8), 496-500.
- Sampson, J. P., Jr., Peterson, G. W., Lenz, J. G., Reardon, R. C., & Saunders, D. E. (1996). *Career Thoughts Inventory: Professional manual*. Odessa, FL: Psychological Assessment Resources.
- Sampson, J. P., Jr., Reardon, R. C., Peterson, G. W., & Lenz, J. G. (2004). *Career counseling & services: A cognitive information processing approach*. Belmont, CA: Brooks/Cole.

- Saunders, D. E., Peterson, G. W., Sampson, J. P., Jr., & Reardon, R. C. (2000). Relation of depression and dysfunctional career thinking to career indecision. *Journal of Vocational Behavior, 56*, 288-298. doi:10.1006/jvbe.1999.1715
- Slaney, R. B. (1980). Expressed choice and vocational indecision. *Journal of Counseling Psychology, 27*, 122-129. doi:10.1037//0022-0167.27.2.122
- Slaney, R. B., Stafford, M., & Russell, J. (1981). Career indecision in adult women: A comparative and descriptive study. *Journal of Vocational Behavior, 19*, 335-345. doi:10.1016/0001-8791(81)90068-3
- Smith, H. M., & Betz, N. E. (2002). An examination of efficacy and esteem pathways to depression in young adulthood. *Journal of Counseling Psychology, 49*, 438-448. doi:10.1037//0022-0167.49.4.438
- Spokane, A. R. (1989). Are there psychological and mental health consequences of difficult career decisions? *Journal of Career Development, 16*, 19-23. doi:10.1007/BF01354264
- Stead, G. B. (1991). *The Career Myths Scale*. Unpublished manuscript, Vista University, Port Elizabeth, South Africa.
- Stead, G. B., & Watson, M. B. (1993). How similar are the factor structures of the Career Decision Scale, the Career Decision Profile, and the Career Factors Inventory? *Educational and Psychological Measurement, 53*, 281-290. doi:10.1177/0013164493053001031
- Stead, G. B., Watson, M. B., & Foxcroft, C. D. (1993). The relation between career indecision and irrational beliefs among university students. *Journal of Vocational Behavior, 42*, 155-169. doi:10.1006/jvbe.1993.1011

- Stewart, R. E., & Chambless, D. L. (2009). Cognitive-behavioral therapy for adult anxiety disorders in clinical practice: A meta-analysis of effective studies. *Journal of Consulting and Clinical Psychology, 77*, 595-606.  
doi:10.1037/a0016032
- Sullivan, K. R., & Mahalik, J. R. (2000). Increasing career self-efficacy for women: Evaluating a group intervention. *Journal of Counseling & Development, 78*(1), 54-62.
- Super, D. E., Thompson, A. S., & Lindeman, R. H. (1988). *Adult Career Concerns Inventory: Manual for research and exploratory use in counselling*. Palo Alto, CA: Consulting Psychologists Press.
- Swanson, J. L., & Tokar, D. M. (1991). Development and initial validation of the Career Barriers Inventory. *Journal of Vocational Behavior, 39*, 344-361.  
doi:10.1016/0001-8791(91)90043-L
- Tabachnick, B. G., & Fidell, L. S. (2007). *Using multivariate statistics* (5th ed.). Boston, MA: Allyn and Bacon.
- Tansley, D. P., Jome, L. M., Haase, R. F., & Martnes, M. P. (2007). The effects of message framing on college students' career decision making. *Journal of Career Assessment, 15*, 301-316. doi:10.1177/1069072707301204
- Taylor, K. M., & Betz, N. E. (1983). Applications of self-efficacy theory to the understanding and treatment of career indecision. *Journal of Vocational Behavior, 22*, 63-81. doi:10.1016/0001-8791(83)90006-4
- Taylor, K. M., & Popma, J. (1990). An examination of the relationships among career decision-making self-efficacy, career salience, locus of control, and vocational

indecision. *Journal of Vocational Behavior*, 37, 17-31. doi:10.1016/0001-8791(90)90004-L

Tinsley, H. E. A. (1992). Career decision making and career indecision. *Journal of Vocational Behavior*, 41, 209-211. doi:10.1016/0001-8791(92)90022-R

Titley, R., & Titley, B. (1980). Initial choice of college major: Are only the “undecided” undecided? *Journal of College Student Personnel*, 21(4), 293-298.

Tokar, D. M., Withrow, J. R., Hall, R. J., & Moradi, B. (2000). Psychological separation, attachment security, vocational self-concept crystallization, and career indecision: A structural equation analysis. *Journal of Counseling Psychology*, 50, 3-19. doi:10.1037/0022-0167.50.1.3

Venning, A., Kettler, L., Elliott, J., & Wilson, A. (2009). The effectiveness of cognitive-behavioural therapy with hopeful elements to prevent the development of depression in young people: A systematic review. *International Journal of Evidence-Based Healthcare*, 7, 15-33. doi: 10.1111/j.1744-1609.2009.00122.x

Vondracek, F. W., Hostetler, M., Schulenberg, J. E., & Shimizu, K. (1990). Dimensions of career indecision. *Journal of Counseling Psychology*, 37, 98-106. doi:10.1037//0022-0167.37.1.98

Wilson, G. T., Grilo, C. M., & Vitousek, K. M. (2007). Psychological treatments of eating disorders. *American Psychologist*, 62, 199-216. doi:10.1037/0003-066X.62.3.199

Zener, T. B., & Schnuelle, L. (1972). *An evaluation of the Self-Directed Search: A guide to educational and vocational planning* (Technical Report No. 124). Baltimore, MD: Johns Hopkins University, Center for the Social Organization of Schools.