

## The University of Southern Mississippi The Aquila Digital Community

---

Let's Build It!

The Importance of Play: A Selected Bibliography of  
Resources Related to Learning Through Play

---

Spring 4-1-2016

# Table with Multiple Tops and Storage

Stacy Creel

Follow this and additional works at: <http://aquila.usm.edu/letsbuildit>

---

### Recommended Citation

Stacy Creel, "Table with Multiple Tops and Storage" (2016). *Let's Build It!*. Paper 1.  
<http://aquila.usm.edu/letsbuildit/1>

This Other is brought to you for free and open access by the The Importance of Play: A Selected Bibliography of Resources Related to Learning Through Play at The Aquila Digital Community. It has been accepted for inclusion in Let's Build It! by an authorized administrator of The Aquila Digital Community. For more information, please contact [Joshua.Cromwell@usm.edu](mailto:Joshua.Cromwell@usm.edu).

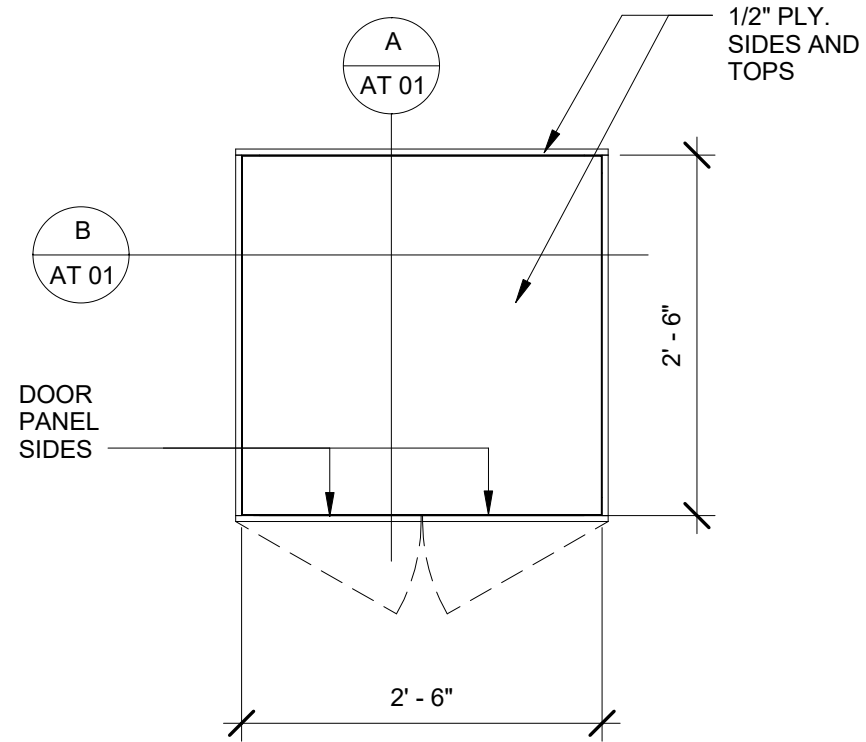

**TOP VIEW**  
3/4" = 1'-0"

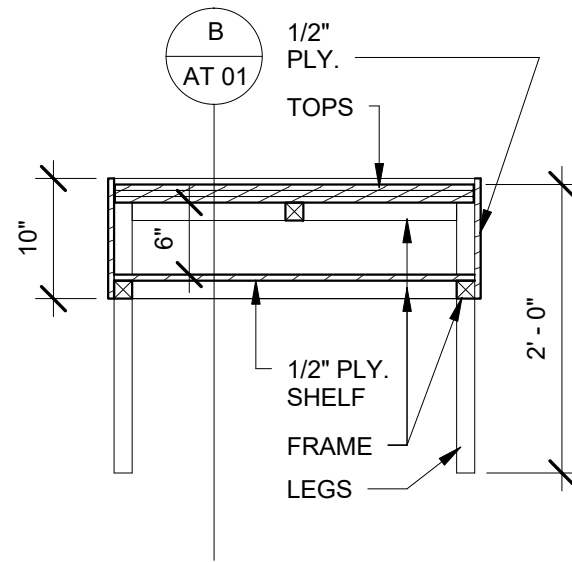

**SECTION A**  
3/4" = 1'-0"

**NOTES:**

1. LEGS AND FRAME TO BE 2X2 FRAMING ASSEMBLED USING WOOD SCREWS COUNTERSUNK AS NECESSARY TO PROVIDE A SMOOTH FINISHED EDGE: FILL AS REQUIRED AND SAND/PREP FOR PAINT.
2. SAND SMOOTH ALL SHARP EDGES INCLUDING LEGS, TOP, AND TRIM CORNERS.
3. SAND, PRIME, AND PREP FOR FINAL PAINT TO BE COMPLETED BY OWNER.
4. FRAME LAYOUT AND DIMENSIONS SHOWN FOR REFERENCE ONLY, FIELD VERIFY AND ADJUST AS REQUIRED TO SUPPORT TOP.
5. REMOVABLE TOPS SHOULD BE CUT, SANDED, AND FINISHED SO THAT THERE IS MIN. 1/16" CLEAR SPACE ON ALL SIDES BETWEEN EDGE OF TOP AND INSIDE FACE OF SIDE PANEL TO ALLOW FOR EASY REMOVAL OF TOPS. (ALLOWING PUSH UP FROM BELOW)
6. REMOVABLE TOPS TO HAVE ROUNDED EDGES, TYPICAL.
7. PROVIDE CONCEALED HINGES AND MAGNETIC LATCH/CATCH HARDWARE TO DOOR SIDE PANELS.



**PROJECT INFORMATION:**  
 ALA C-W AWARD GRANT  
 ATTN: STACY CREEL  
 THE UNIVERSITY OF SOUTHERN MISSISSIPPI  
 118 COLLEGE DRIVE  
 HATTIESBURG, MS

PRELIMINARY

**SHEET TITLE:**

ACTIVITY TABLE  
 DESIGN

**SCALE:**

3/4" = 1'-0"

**DRAWN BY:**

SG

**DATE:**

12-2015

**SHEET #**

**AT 01**

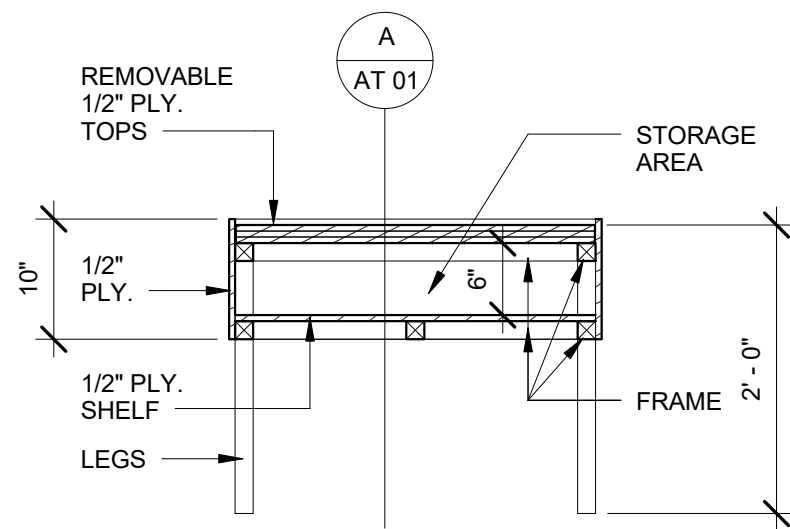

**SECTION B**  
3/4" = 1'-0"