

Gulf Research Reports

Volume 7 | Issue 2

January 1982

Evaluation of Flow-Through, Static, and Recirculating Systems for the Intensive Culture of the Gulf Killifish *Fundulus grandis* with Observations on a Solar-Heated Recirculating System for the Bait Industry

John T. Ogle

Gulf Coast Research Laboratory

Mobashir A. Solangi

Gulf Coast Research Laboratory

DOI: 10.18785/grr.0702.06

Follow this and additional works at: <http://aquila.usm.edu/gcr>

 Part of the [Marine Biology Commons](#)

Recommended Citation

Ogle, J. T. and M. A. Solangi. 1982. Evaluation of Flow-Through, Static, and Recirculating Systems for the Intensive Culture of the Gulf Killifish *Fundulus grandis* with Observations on a Solar-Heated Recirculating System for the Bait Industry. *Gulf Research Reports* 7 (2): 151-156.

Retrieved from <http://aquila.usm.edu/gcr/vol7/iss2/6>

This Article is brought to you for free and open access by The Aquila Digital Community. It has been accepted for inclusion in Gulf and Caribbean Research by an authorized editor of The Aquila Digital Community. For more information, please contact Joshua.Cromwell@usm.edu.

EVALUATION OF FLOW-THROUGH, STATIC, AND RECIRCULATING SYSTEMS FOR THE INTENSIVE CULTURE OF THE GULF KILLIFISH *FUNDULUS GRANDIS* WITH OBSERVATIONS ON A SOLAR-HEATED RECIRCULATING SYSTEM FOR THE BAIT INDUSTRY

JOHN T. OGLE AND MOBASHIR A. SOLANGI
*Oyster Biology and Parasitology Sections,
Gulf Coast Research Laboratory,
Ocean Springs, Mississippi 39564*

ABSTRACT Three systems (flow-through, static, and recirculating) for intensive culture of the Gulf killifish (*Fundulus grandis*) for bait were evaluated. The outdoor recirculating system proved most successful. Killifish maintained in this system attained an average weight of over 2.0 gm in 42 days, an acceptable market size. Whereas the solar-heated recirculating system sustained fish densities equivalent to 1,000,000/ha and a survival rate of 86%, growth of killifish in this system was less than that observed in both the static and outdoor recirculating systems. Algae appeared to be an important nutritional component of the diet of juvenile killifish. Individuals of *F. grandis* fed diets supplemented with algae grew better than those maintained without them.

INTRODUCTION

The Gulf killifish *Fundulus grandis* Baird and Girard, is used extensively as a live bait along the northern Gulf of Mexico and supports a growing bait industry (McIlwain 1977, Tatum and Helton 1977, Tatum et al. 1978). However, supply of killifish-bait rarely meets the demand, especially during fall when the need is greatest (McIlwain 1977, Tatum et al. 1978). To fill this need, several attempts have been made to propagate killifish. Although the current and predominant method of rearing *F. grandis* is in earthen ponds (see Tatum et al. 1978), McIlwain (1977), based on limited experiments, suggested the feasibility of recirculating systems for killifish culture. Closed recirculating systems, in addition to providing some control over environmental parameters such as temperature, salinity, dissolved oxygen, and pH, require less space and aid in eliminating certain debilitating parasitic infections of killifish (see Solangi and Overstreet 1980, Solangi and Ogle 1981).

This paper reports results of several experiments on killifish culture in closed systems with preliminary observations on a solar-heated recirculating system that shows promise for the bait-fish industry.

MATERIALS AND METHODS

Laboratory-reared *Fundulus grandis* were obtained by stripping gravid male and female killifish collected from Halstead Bayou, Ocean Springs, Mississippi. Prior to experimentation, parasite-free fish were maintained in 60-l aquaria in Instant Ocean[®] at 25 ‰ salinity and 24 ± 2°C temperature, and were fed daily *ad libitum* a ration of TetraMarin[®]. Experiments were conducted to compare

flow-through, static, and recirculating systems for killifish culture and determine the effects of various diets on growth of *F. grandis*. Unless otherwise noted, tests were conducted in duplicate, and experimental fish were fed *ad libitum* a ration of Bama[®] Minnow Chow. Growth was calculated by differences in weight gained, and statistical analyses on growth data were conducted using procedures of Campbell (1967).

Flow-through System

Growth and survival of killifish in an outdoor flow-through system was studied. Two 4000-l circular tanks, 2.5 m in diameter, (Fig. 1a) were filled with seawater from Biloxi Bay. Ambient bay water was pumped through the flow-through tank at a rate of 12 l/min. Overflowing water was removed through a slotted standpipe and venturi arrangement. Salinity and temperature of the Bay water ranged from 1 to 14 ‰ and 22 to 30°C, respectively. Juvenile killifish at the beginning of the experiment were 30 days old and weighed an average of 11 ± 1 (S.E.) mg. Five hundred fish were introduced into each of the flow-through tanks. At the end of the experiment all surviving fish were counted and measured.

Static System

This experiment was conducted to study growth and survival of killifish reared in outdoor static tanks. Two tanks (Fig. 1b), each a rectangular box (1.8x3.6 m) constructed of wood, lined with plastic, and without the filters as indicated in the figure, were filled with approximately 3,300 l of seawater at 20 ‰ which was not exchanged during the 58-day experimental period. Killifish at the beginning of the experiment were 45 days old and averaged 149 ± 26 (S.E.) mg.

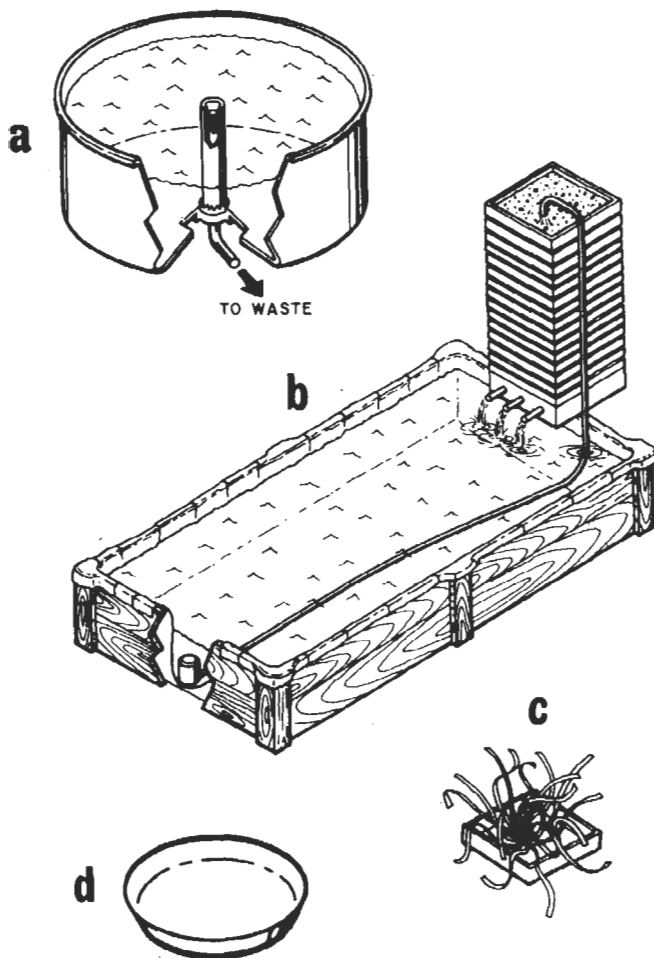

Figure 1 (a-d). Various containers used in experimental studies on killifish.

In addition to the aforementioned two tanks, a third static tank was used to observe the effect of algae in the system on growth and survival of killifish. The tank was filled with approximately 3,300 l of seawater at 20 ‰ and, after the addition of 165 killifish, fertilized with about 200 g of cottonseed meal to initiate a phytoplankton bloom. Fish at the beginning of the experiment were 45 days old and weighed an average of 149 ± 26 (S.E.) mg. Seawater was not exchanged during the 72-day experiment; all surviving fish were counted and measured. This test was not run concurrently with the previous one.

Recirculating systems

Growth and survival of killifish in two systems, outdoor recirculating tanks and a solar-heated recirculating raceway, were studied.

The two outdoor recirculating tanks (Fig. 1b) were the same tanks used in the static tests, except that now each tank was fitted with a trickle-through filter at one end.

These filters consisted of a stack of 15 perforated plastic trays 58x58 cm packed with styrofoam chips. A submersible 1/8-hp pump with a flow rate of 12 l/min was used to pump seawater to the top of each filter and it was allowed to percolate down the filter before entering the tank. In addition to the filter, one of the tanks received three habitats (additional surface area) each consisting of a plastic tray with approximately 1-m long plastic strips woven through it (Fig. 1c). Both tanks were filled with approximately 3,300 l of seawater at 20 ‰ and stocked with 165 120-day-old fish averaging 764 ± 32 (S.E.) mg. After the fish were introduced into the system, the seawater was fertilized by adding approximately 200 gm of cottonseed meal. The experiment ran for 42 days, at the end of which surviving fish were counted and measured.

The solar-heated recirculating system consisted of a raceway housed in a passive solar-heated greenhouse (Fig. 2). The rectangular raceway, 7.9x1.8x0.6 m, with circular ends had a lengthwise panel holding 28 PVC airlifts each approximately 3.8 cm in diameter. Because of the small size of the fish at stocking and the strong currents produced by the airlifts, the air system was turned on for 1 hour three times a day. Water from the raceway was pumped into a 450-l conical settling tank by means of a submersible pump and then flowed by gravity to updraft trickle-through filter boxes, 1.2x0.6 m, stacked in three banks of three boxes each. Water, after passing through the filters, returned to the raceway at the end opposite to the intake. The entire raceway and all associated filters were housed in an insulated building with a window facing south and inclined at 45° for maximal winter solation. The window could be closed by six insulated panels thereby allowing control over water temperature. The raceway was stocked with 670 30-day-old fish weighing an average of 149 ± 26 (S.E.) mg. The experiment lasted 72 days after which all surviving fish were counted and measured.

Diet

To determine whether algae in the diet affected growth and survival of killifish, we introduced 15 fish, averaging 78 ± 8 (S.E.) mg, into each of the six static circular plastic pools (see Fig. 1d) with approximately 40 l of algal water obtained from a large outdoor algae culture tank. Three duplicated diet regimens were used—no food (control), Purina® Trout Chow, and a mixture of Trout Chow and frozen oysters. To serve as control, 15 fish in each of six additional pools were provided with filtered bay water instead of algal water and were fed the aforementioned diet regimens. Salinity and temperature in each pool remained at 20 ± 2 ‰ and 25 ± 2 °C, respectively. The tests were run for 38 days, at which time all surviving fish were counted and measured.

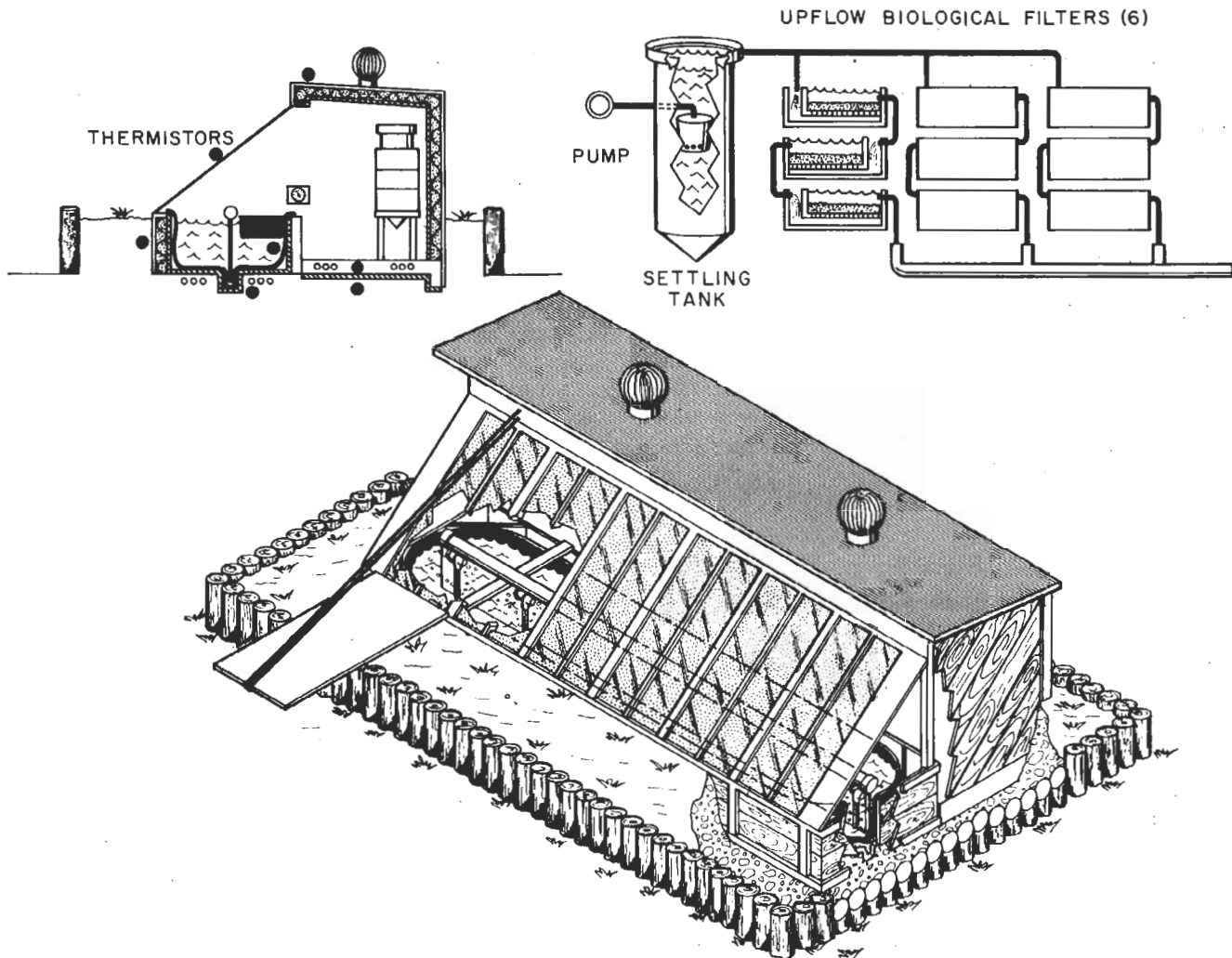

Figure 2. Design of the solar-heated recirculating system used for killifish culture.

RESULTS

Flow-through system (Table 1)

Killifish in tank A grew approximately 92 times their original body weight during the 58-day experiment; however, they did not achieve an acceptable market size (1.5 to 2.0 gm). Fish in tank B did not grow as well as those in tank A, and, in addition, suffered an extremely high rate of mortality (Table 1). No algal blooms were observed in either flow-through tank during the experiment.

Static system (Tables 2 and 3)

Killifish in static tanks A and B (non-fertilized) did not reach a marketable size during the 58-day test (Table 2). However, fish in outdoor static tank C, which was fertilized to promote algal growth and maintained at approximately half the density of the previous test, reached marketable size during the 72-day experiment. Some algae was observed in tanks A and B during the study; however, dense blooms

of mainly unicellular algae were observed in the tank that was fertilized.

Recirculating systems

Outdoor recirculating tanks (Table 4) – Killifish in both tanks exceeded the acceptable market size of 2.0 gm in 42 days. These results, however, are based on a random subsample of 21 individuals from each tank taken on day 42. The reason for this is because the experiment had to be terminated on day 55, when the majority of the fish from both tanks were lost due to an overflow problem. Based on data in table 4, provision of additional surface area (habitat) to tank B did not significantly ($P < .001$) affect growth of killifish. Dense algal blooms were observed in both tanks during the experiment.

Solar-heated raceway (Table 5) – Killifish in this system did not achieve an acceptable market size during the 72-day test. No algal blooms were observed in the raceway throughout the experiment.

TABLE 1.
Growth and survival of killifish after 58 days in an outdoor flow-through system.¹

	TANK A	TANK B
Initial number of fish	500	500
Sample size at harvest	294	64
Average initial weight, mg ($\bar{x} \pm S.E.$) (N=164)	11 \pm 1	11 \pm 1
Average weight at harvest, mg ($\bar{x} \pm S.E.$)	1020 \pm 46	180 \pm 10
Weight gain, mg	1009 (93x)	169 (16x)
Survival, %	59	13

¹Experimental period: 25 April to 21 June 1979; stocking density 500,000/ha; initial age of fish: 30 days.

TABLE 2.
Growth and survival of killifish after 58 days in an outdoor static system.¹

	TANK A	TANK B
Initial number of fish	411	457
Sample size at harvest	293	292
Average initial weight, mg ($\bar{x} \pm S.E.$) (N=164)	11 \pm 1	11 \pm 1
Average weight at harvest, mg ($\bar{x} \pm S.E.$)	910 \pm 48	560 \pm 30
Weight gain, mg	899 (83x)	549 (51x)
Survival, %	71	63

¹Experimental period: 25 April to 21 June 1979; stocking density 500,000/ha; initial age of fish: 30 days.

TABLE 3.
Growth and survival of killifish after 72 days in an outdoor static tank.¹

	TANK C ²
Initial number of fish	165
Sample size at harvest	148
Average initial weight, mg ($\bar{x} \pm S.E.$) (N=66)	149 \pm 26
Average weight at harvest, mg ($\bar{x} \pm S.E.$)	2613 \pm 118
Weight gain, mg	2464 (18x)
Survival, %	90

¹Experimental period: 17 April to 18 June 1980; stocking density 250,000/ha; initial age of fish: 45 days.

²Seawater contained dense cultures of unicellular algae.

TABLE 4.
Growth of killifish after 42 days in outdoor recirculating tanks.¹

	TANK A	TANK B ²
Initial number of fish	165	165
Sample size at harvest	21	21
Average initial weight, mg ($\bar{x} \pm S.E.$)	764 \pm 32	764 \pm 32
Average weight at harvest, mg ³ ($\bar{x} \pm S.E.$)	2374 \pm 108	2021 \pm 135
Weight gain, mg	1610 (3x)	1257 (2.6x)

¹Experimental period: 26 June to 6 August 1980; stocking density 250,000/ha; seawater contained dense cultures of algae; initial age of fish: 120 days.

²Tank with additional surface area (habitat).

³No significant ($P < .001$) difference between weights of the two groups (t-Test).

TABLE 5.
Growth and survival of killifish after 72 days in a solar-heated recirculating raceway.¹

	Solar-heated raceway
Initial number of fish	670
Sample size at harvest	572
Average initial weight, mg ($\bar{x} \pm S.E.$) (N=66)	149 \pm 26
Average weight at harvest, mg ($\bar{x} \pm S.E.$)	764 \pm 32
Weight gain, mg	615 (5x)
Survival, %	86

¹Experimental period: 17 April to 18 June 1980; stocking density 1,000,000/ha; no algal blooms observed throughout experiment; initial age of fish: 45 days.

Diet

As indicated by data in Table 6, killifish fed diets supplemented with mixed cultures of live algae gained significantly more weight ($P < .05$) than those maintained in filtered seawater. Furthermore, fish fed a mixture of Purina[®] Trout Chow with oyster meat grew significantly larger ($P < .05$) than those killifish fed exclusively on Purina Trout Chow or those not fed during the entire experiment (Table 6).

No detailed analyses were attempted of the species composition of the algal blooms. However, occasional microscopic examination of the algae culture revealed the presence of several unicellular algal species such as *Chlorella*, *Chlamydomonas*, and unidentified diatoms.

DISCUSSION

Based on our observations, very little control over such environmental parameters as temperature and salinity, and

TABLE 6.

Effect of algal water and various diets on growth and survival of killifish maintained in static pools for 38 days.¹

	Bay Water			Algal Water		
	Unfed ²	Trout Chow ³	Mixture ⁴	Unfed ²	Trout Chow ³	Mixture ⁴
Sample size at harvest	13	25	25	19	30	29
Average weight at harvest (mg) ($\bar{x} \pm S.E.$)	63±1	110±2	170±3	74±7	156±13	253±41
Weight gain, %	-19	41	118	-6	100	224
Average survival, %	43	83	84	63	100	97

¹Stocking rate: 15 fish/tank; Average stocking weight (mg) 78 ± 8 (S.E.); Experimental period: 7 July to 24 August 1980.²No significant (P < .05) difference between weights of the two groups. (t-Test)³Significant (P < .05) difference between weights of the two groups. (t-Test)⁴Significant (P < .05) difference between weights of the two groups. (t-Test)

TABLE 7.

Comparison of average daily weight gain of killifish in flow-through, static, and recirculating systems.

	Stocking density	Average initial weight (mg)	Age at stocking	Average final weight (mg)	Average weight gain (mg/day)
Flow-through system ¹					
Tank A	500,000/ha	11±1	30	1020±46	17.4
Tank B	500,000/ha	11±1	30	180±10	3.0
Static system ²					
Tank A	500,000/ha	11±1	30	910±48	15.5
Tank B	500,000/ha	11±1	30	560±30	9.5
Tank C ³	250,000/ha	149±26	45	2613±118	34.3*
Recirculating systems					
Outdoor recirculating ⁴					
Tank A	250,000/ha	764±32	120	2374±108	38.4*
Tank B	250,000/ha	764±32	120	2021±135	30.0*
Solar-heated recirculating					
Tank A	1,000,000/ha	149±26	45	764±32	8.6**

1, 2, 3, 4 : Data for Tables 1, 2, 3, and 4 respectively.

*Dense algal cultures present in system throughout the study.

**No algal blooms observed throughout the study.

other water-quality conditions was possible in the flow-through system. Poor growth and high mortality in this system could be attributed to wide fluctuations in temperature and salinity, and possibly to such water-quality parameters as silt in the incoming seawater. Unless methods can be developed to control some of the aforementioned parameters, a flow-through system as described does not appear to be a reliable method for killifish production.

Algae in the diet appear to fulfill some of the nutritional needs of cultured killifish. Fish fed diets supplemented with algae grew better than those maintained without them (see Table 7). Although we did not critically evaluate the amount or type of algae consumed by *F. grandis*, gut analyses of several fish reared in tanks with algae revealed large quan-

ties of organic material composed mainly of detritus, diatoms, unicellular algae, and bacteria. Food content analyses of several *Fundulus* species (*F. heteroclitus*, *F. confluentus*, and *F. luciae*) conducted by Harrington and Harrington (1972), Kneib (1978), and Kneib and Stiven (1978) also show algae and other plant and organic material to be an important component of the diet of killifishes, especially of juveniles in the 29- to 59-mm range during summer and fall (Harrington and Harrington 1972, Kneib and Stiven 1978). However, further analyses of the algal composition in the killifish culture facility to determine its nutritional value, and effect of various algal species on growth of *F. grandis* are needed and should prove rewarding.

In addition to algae in the system, fish densities affected growth of killifish. As indicated by data in Table 7, a density of 250,000 fish/ha appeared sufficient for killifish to achieve an average weight of 2 gm or more within 42 to 72 days. However, since not all experiments were conducted concurrently, variation in average weight gain among killifish at the same or different densities could have been influenced by environmental conditions at the time of each experiment.

Of the three systems examined (static, flow-through, and recirculating), the outdoor recirculating system proved most successful. Killifish in this system achieved marketable size within 42 days of the experiment. However, maintaining optimum water temperature and over-wintering killifish in this system would be a problem. On the other hand, the solar-heated raceway appears to be an attractive alternative to outdoor tanks and could be used in the bait-fish industry. The poor growth in the raceway during this study might be attributed to the lack of algae in the system (see Table 7). This problem can be easily remedied by replacing the up-draft trickle-through filters with a biodisc, and promoting

algal growth in the raceway. Furthermore, in addition to requiring less space and providing the bait farmer control over many environmental parameters, the solar-heated recirculating system can effectively prevent the entry into the system of the grass shrimp *Palaemonetes pugio*, an intermediate host of the pathogenic coccidium *Eimeria funduli* (Solangi and Overstreet 1980, Solangi and Ogle 1981). Preliminary studies by Solangi and Ogle (1981) indicate that this parasite, when present, can considerably affect growth of killifish. Although the solar-heated recirculating system shows promise for culture of killifish, additional studies on the economic feasibility of such a system for the bait industry, and comparison of currently used methods for killifish culture are essential and should prove valuable to the bait farmer.

ACKNOWLEDGMENTS

Dr. Adrian R. Lawler, Steven Shepard, and William Falls (Gulf Coast Research Laboratory) provided laboratory-reared killifish, Dr. Robin Overstreet commented on the manuscript, and Lucia O'Toole typed the paper.

REFERENCES CITED

- Campbell, R. C., 1967. Statistics for Biologists. Cambridge University Press, U.K.
- Harrington, R. W. & E. S. Harrington, 1972. Food of female marsh killifish *Fundulus confluentus* Goode and Bean, in Florida. *Am. Midl. Nat.* 87(2):492-502.
- Kneib, R. T. & A. E. Stiven, 1978. Growth, reproduction, and feeding of *Fundulus heteroclitus* (L.) on a North Carolina salt marsh. *J. Exp. Mar. Biol. Ecol.* 31(2):121-140.
- Kneib, R. T., 1978. Habitat, diet, reproduction and growth of the spotfin killifish, *Fundulus luciae*, from a North Carolina salt marsh. *Copeia* (1):164-169.
- McIlwain, T. D., 1977. Bait fish rearing. Miss. Mar. Resour. Comm., Mississippi, Project GR-76-005, 14 pp.
- Solangi, M. A. & R. M. Overstreet, 1980. Biology and pathogenesis of the coccidium *Eimeria funduli* infecting killifishes. *J. Parasitol.* 66(3):513-526.
- Solangi, M. A. & J. T. Ogle, 1981. Preliminary observations on the effect of *Eimeria funduli* (Protozoa: Eimeriidae) on the Gulf killifish *Fundulus grandis* and its potential impact on the killifish bait industry. *Gulf Res. Rept.*
- Tatum, W. M. & R. F. Helton, 1977. Preliminary results of experiments on the feasibility of producing bull minnows (*Fundulus grandis*) for the live bait industry. Proc. 8th Annu. Meet. World Maricult. Soc., San Jose, Costa Rica. Pp. 49-54.
- Tatum, W. M., W. C. Trimble, & R. F. Helton, 1978. Production of Gulf killifish in brackish water ponds. *Proc. of 32nd Annu. Conf. Southeast. Assoc. of Fish & Wildlife Agencies.* Pp. 502-508.