



**Escola Politècnica Superior
de Castelldefels**

UNIVERSITAT POLITÈCNICA DE CATALUNYA

PROYECTO FIN DE CARRERA

TITLE: Estudio de estrategias de selección del formato de transmisión para el enlace ascendente en sistemas WCDMA.

AUTHOR: Olga Adrià Serrano

DIRECTOR: Juan Sánchez González

DATE: 30 de noviembre de 2007

To Antonio for his help in all aspects during all the project time. I want to thank to my parents, for their advices and their support, too. And finally I want to mention my sister Dèlia for her smile in hard moments.

Title: Study of strategies of selection of the transmission format for the uplink in systems WCDMA

Author: Olga Adrià Serrano

Director: Juan Sánchez González

Date: 30th November 2007

Overview

The proposed PFC is in the framework of Radio Resources Management and Quality of Service (QoS) for CDMA based radio access networks (such as UMTS). One of the fundamental facts of these systems is to provide different types of multimedia services in order to guarantee certain quality requirements in the connections.

The Radio Resources Management strategies (RRM) are in charge of controlling the different radio network parameters so guaranteeing the quality required to the connections and making a use efficient of the resources available. For the case of the uplink, it is very important to determine the format of transmission of the users, i.e., the rate of transmission that the user will have at every moment.

The main objective of this PFC is to propose and to evaluate different strategies of user transmission format allocation in order to optimize the trade-off between the delay and the level of interferences that is added to the system.

A simulator programmed in C is available. This simulator models a real WCDMA system. With this simulator is possible to analyze the power condition, which is important for our study in this project.

The study of this algorithm demonstrates how the user bit rate affects in the cell. By controlling the maximum power of each user, we can know if there are cell coverage problems. The analyses show the differences of having droppings or not with the new algorithm and the delay variation.

Título: Estudio de estrategias de selección del formato de transmisión para el enlace ascendente en sistemas WCDMA

Autor: Olga Adrià Serrano

Director: Juan Sánchez González

Fecha: 30 de noviembre de 2007

Resumen

El PFC propuesto está enmarcado dentro de la gestión de recursos radio y calidad de servicio (QoS) por los sistemas con acceso del tipo WCDMA (como por ejemplo UMTS). Uno de los hechos fundamentales de estos sistemas es proporcionar diferentes tipos de servicios multimedia tratando de garantizar unos ciertos requerimientos de calidad en las conexiones.

Las estrategias de gestión de recursos radio (RRM) son las encargadas de controlar los diferentes parámetros de la red radio con tal de garantizar la calidad requerida a las conexiones y hacer un uso eficiente de los recursos disponibles. Para el caso del enlace ascendente, resulta muy importante determinar el formato de transmisión de los usuarios, es decir, la tasa de transmisión que tendrá el usuario en cada momento.

El principal objetivo de este PFC es proponer y evaluar diferentes estrategias de asignación del formato de transmisión de los usuarios con tal de optimizar el compromiso entre el retardo y el nivel de interferencias que se añade al sistema.

Se dispone de un simulador programado en C que modela un sistema WCDMA real. De esta manera, se ha podido analizar la condición de potencia, importante para nuestro estudio en este proyecto.

El estudio de este algoritmo, nos demuestra como interfiere en la celda la velocidad de transmisión de los usuarios. Controlando la potencia máxima de cada usuario podemos saber si estos pueden tener problemas de conexión. Si es así al variar la velocidad de transmisión conseguimos una mejora en la cobertura de la celda. Los análisis muestran las diferencias en las pérdidas de conexiones y la variación del retardo.

INDEX

INTRODUCTION	2
CHAPTER 1. UMTS.....	3
1.1. Introduction	3
1.2. UMTS evolution of the 2G systems.....	3
1.3. UMTS Description.....	6
CHAPTER 2. W-CDMA.....	13
2.1. History and evolution	13
2.2. CDMA concept.....	13
CHAPTER 3. Radio Resources Management.....	16
3.1. Introduction	16
3.2. Strategies RRM	16
CHAPTER 4. Analysis of the Cell Coverage.....	22
4.1. Introduction	22
4.2. Formulation.....	22
4.3. Proposed bit rate reduction algorithm.....	26
CHAPTER 5. Simulator	29
5.1. Simulator.....	29
5.2. Considered system model	33
CHAPTER 6. Simulations Results	34
6.1. Introduction	34
6.2. Reference Results when no bit rate reduction is applied	34
6.3. Proposed bit rate reduction algorithm results	36
CONCLUSIONS	42
BIBLIOGRAPHY	44
ANEXO 1. BIT RATE REDUCTION ALGORITHM	45
ANEXO 2. GRAPHICS.....	50
ANEXO 3. TABLES	56

INTRODUCTION

UMTS was born with the objective to improve on the limitations of the second generation mobile, being able to offer multimedia services. It was created to provide multimedia service that requires higher bit rates. UMTS appears because there were new burst's services.

The physical layer of UMTS is based on the acces technique by WCDMA broadband code division. The WCDMA access networks provide an inherent flexibility in the third generation mobile multimedia services. The radio interface capacity optimization is done with algorithms of Radio Resources, which consider the levels of interference in the system. These algorithms are the congestion control, the admission control, the power control, the suitable transport format management and handover management.

In order to be able to understand the Radio Resources Management in UMTS this project has been structured so that in the first chapter it is explained briefly what UMTS is, next, in the second chapter there is an introduction to the WCDMA access technique. In chapter 3 we were centered in the Radio Resources Management, having explained most precise. The next chapter shows the cell coverage study, and the new algorithm implemented in this project. In chapter 5, the system simulator used is explained. And before the conclusions, are the results chapter, explaining the difference of doing the new algorithm or not.

Basically, this work consists on the study of the Radio Resources Management and the simulations results with the objective to evaluate the cell coverage study realized in chapter 3. In order to make this task, it had not to consider no type of environmental considerations, because this project is an theoretical work. A possible environmental study in this subject could be given, if the possible electromagnetic waves about the antennas of mobile telephony or the batteries of the terminals, the materials used in the manufacture, etc. will be.

CHAPTER 1. UMTS

1.1. Introduction

UMTS is a third generation mobile communication system. Their acronyms make reference to the Universal Mobile Telecommunications Services and belong to global family IMT-2000. UMTS is having an important role at the moment for the wireless communications multimedia of high quality, which will reach anywhere in the world to 2000 million users in 2010. In the last twelve years, UMTS has been object of intense efforts of investigation and development anywhere in the world. A support numerous and important manufacturers and operators of telecommunications has been done, since it represents a unique opportunity to create a massive market for the access to the Society of the Information of highly customized mobile services.

Let us see, then, how it was created and its basic characteristics. First we will explain UMTS like the evolution of the 2G system and the characteristics type of service, in which spectrum works, etc. And later we will be able to see a system description, the architecture and the radio access network.

1.2. UMTS evolution of the 2G systems

1.2.1. Creation of the 3G systems

GSM system supposed a revolution with respect to the analogical systems when introducing the digital techniques. The digitalization allowed to reduce the manufacture costs and to improve, remarkably, the number of communications that could be attended in the available bandwidth.

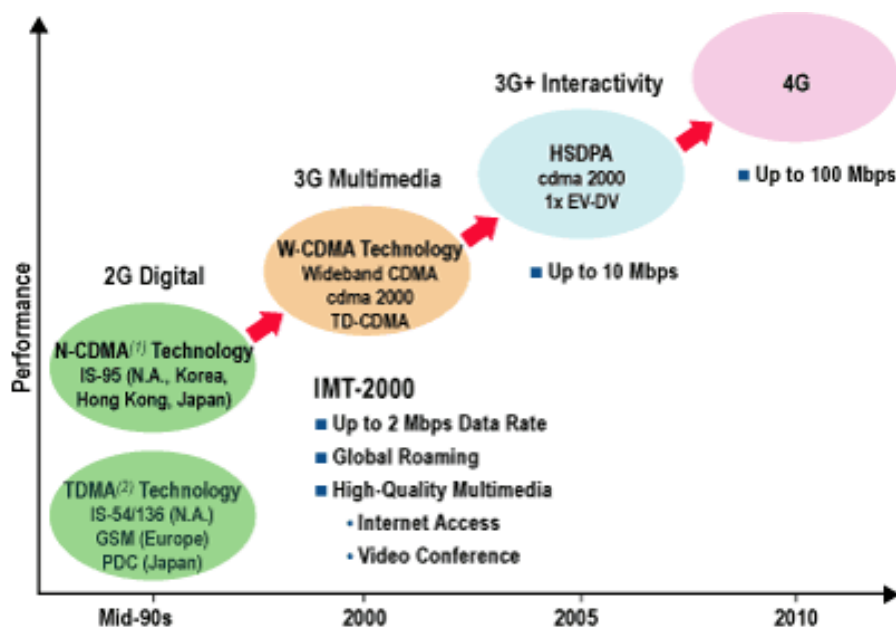

Figure 1.1 Mobile communications system Evolution.

The most important reason of this increase of connections was that the digital systems allow that the operators can reuse the carriers more frequently. This option permits to operators have higher number of connections, for a given available spectrum.

However, the levels of use of GSM system are, mainly in cities, very high. For that reason many solutions have been applied to improve the GSM spectral efficiency. All of them are quite effective, as the use of the power control in the downlink, the use of the SFH (Slow Frequency Hopping), etc.

In spite of the improvements of the GSM spectral efficiency, in the middle of years 90, the ETSI began the definition of a standard. They wanted a continuation of the GSM that allowed more spectral efficiency and cell coverage to support new multimedia services. The ITU continued what they began in the ETSI, at the moment that the European norm had an international character. So, a standardization of the new system the ITU is in charge, but the technical work is made with projects of 3GPP (Third Generation Partnership Project) and 3GPP2 (American specific standardization).

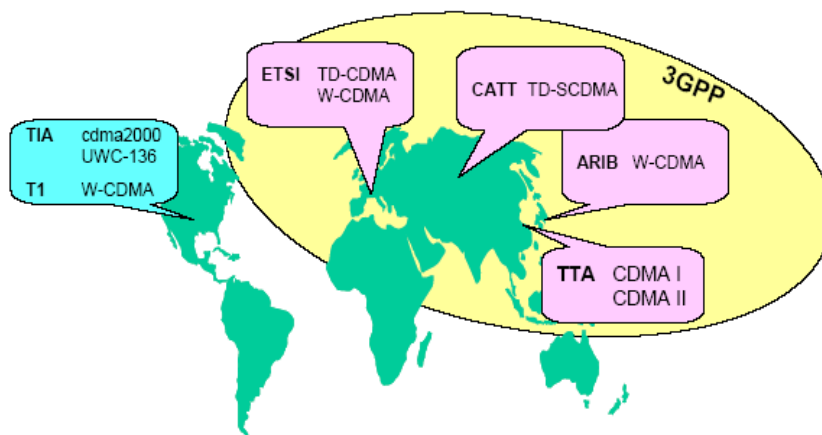

Figure 1.2 3GPP actuation places.

In this way new systems are trying of satisfy the new services demand, increasing the capacity and guaranteeing the cell coverage.

This increase in the users' number brings as result an increase of the traffic. At the beginning, the traffic can be served placing more transceivers on the bases stations. Nevertheless, this is not possible since each carrier must use a different frequency and the spectrum total destined to the mobile communications and assigned by the administrations of each country is limited.

Another way to improve the capacity is to place more base stations. Nevertheless, this is a very expensive process, because it demands new locations with its corresponding licenses, renting, more energy, equipment, etc.

So, for the third generation systems, the solution to improve the spectral efficiency is the CDMA techniques. The main interest of CDMA resides in that it

is more efficient spectrally since it comes near to the ideal conditions. This allows to optimize the capacity of the channels and to take advantage of the pauses in the conversation and data communication.

Obviously, CDMA also has some disadvantages that do not appear in TDMA; most important is the necessity to use a more very strict power control than the TDMA power control. This power control demand can mean that it must transmit an excess of information that reduces the useful capacity available. In addition, for a transmission in bursts, it will be necessary to make an adjustment of the previous levels to the transmission, with the consistent delay.

1.2.2. UMTS Services

The UMTS services are framed in some of the categories defined by the ITU for the IMT-2000 systems. These categories are:

- **Conversational services:** they are services in real time, generally bidirectional and with strong demands as far as delays that must be low and constant. Examples of this type of services are the voice, video calling or the videogames.
- **Streaming:** they are almost unidirectional services, in which a user receives a sequence of data that contains a continuous data flow. In this class it is essential that the values of delay remain constant. An example of this type of applications is the video transmission.
- **Interactive services:** they correspond to those cases in which the user requires data of a remote time. In these services, it is important not to incur excessive delays, as well as to preserve a low error rate. Examples of this category are navigation Web or the enquiry of data bases connected via UMTS.
- **Background:** with these services we can send or receive data files with little strict requirements of delay, since it interests plus the data integrity. An example of this type of services is the electronic mail.

1.2.3. UMTS spectrum

Figure 1.3 shows a graph of the spectrum allocation for the third generation systems in the great geo-economic blocks. In Europe, UMTS is the implementation of the third generation system. Let us remember that 3GPP, which works in the standardization of UMTS, includes all the work blocks of the countries advanced except in U.S.A. that has their own work group, 3GPP2.

The bands for UTRA (UMTS Terrestrial Radio Access Network) are 1900 to 1980 MHz, 2010 to 2025 MHz and 2110 to 2170 MHz. The marked allocations as MSS in the band of 2GHz are for services via satellite. According to the decision of the UE, a band of 80MHz will have at least to be available in Europe for the UMTS/IMT-2000 operators increasing the band available until reaching the 155 MHz to subject the demands of the market.

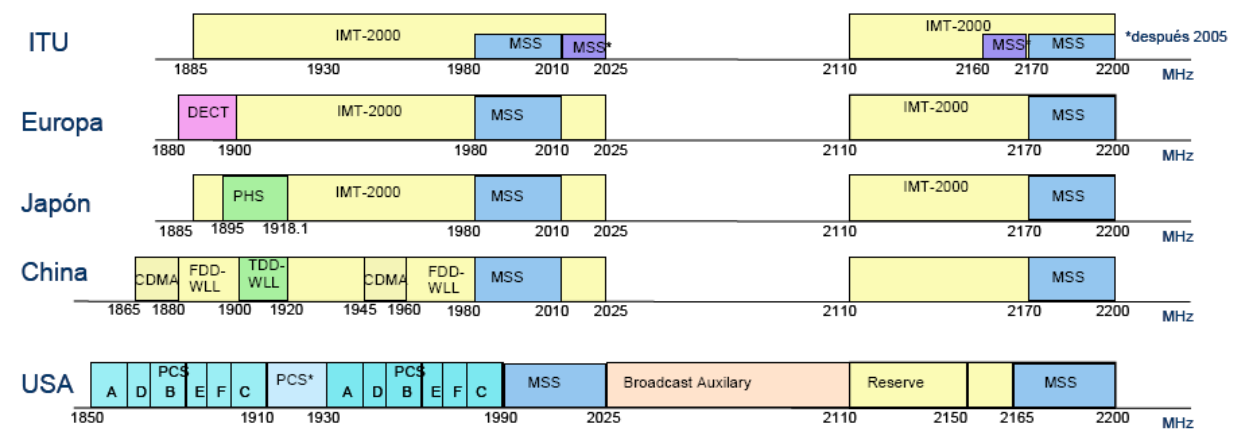

Figure 1.3 The UMTS spectrum allocation.

1.3. UMTS Description

1.3.1. UMTS Architecture

An UMTS network consists on the following elements:

- Core Network
- UTRAN
- Mobile terminals

The following figure illustrates this structure. Some of these elements will be analyzed ahead.

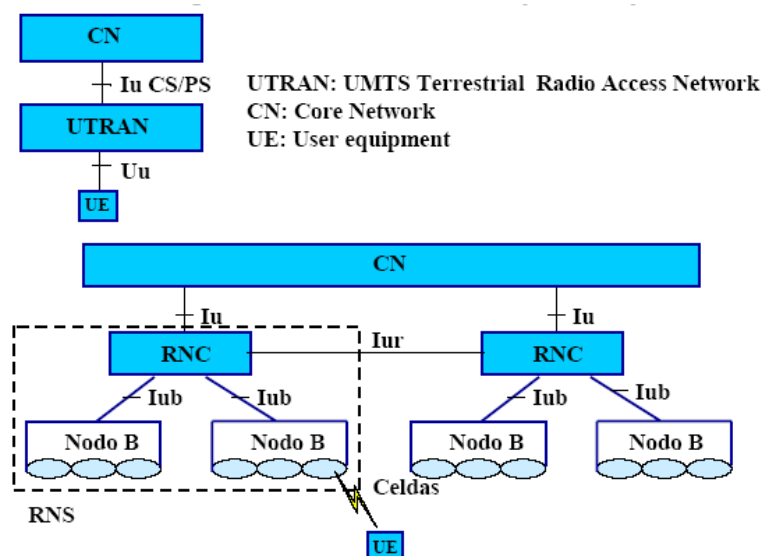

Figure 1.4 UMTS Architecture.

1.3.1.1. Core Network

In GSM network is frequent to find that the transport and service planes are integrated on the same element of network, typically in a power station MSC (Mobile Switching Centre).

However, UMTS networks construct both planes on different elements and therefore the services plane becomes independent from the transport plane, therefore we were with two differentiated planes. The transport planes are based on the communication level and on the control level.

The transport plane is a plane that acts between the control plane and the user Plane. The introduction transport plane is performed in a way that the Application Protocol in the Radio Network Control Plane is kept completely independent of the technology selected for Data Bearer in the User Plane.

The connectivity or commutation level can be contemplated as a resources layer distributed for the traffic management. This plane is constituted in first instance by the Media Gateway (MGW) that processes the information of the users and acts like access commutators to the main network (backbone).

The control level consists on different types of network servers like MSC, GSN, HLR (Home Location Register), SCP (Service Control Point), etc. These and other servers control the security, mobility, the establishment and the session's disconnection, additional services, etc.

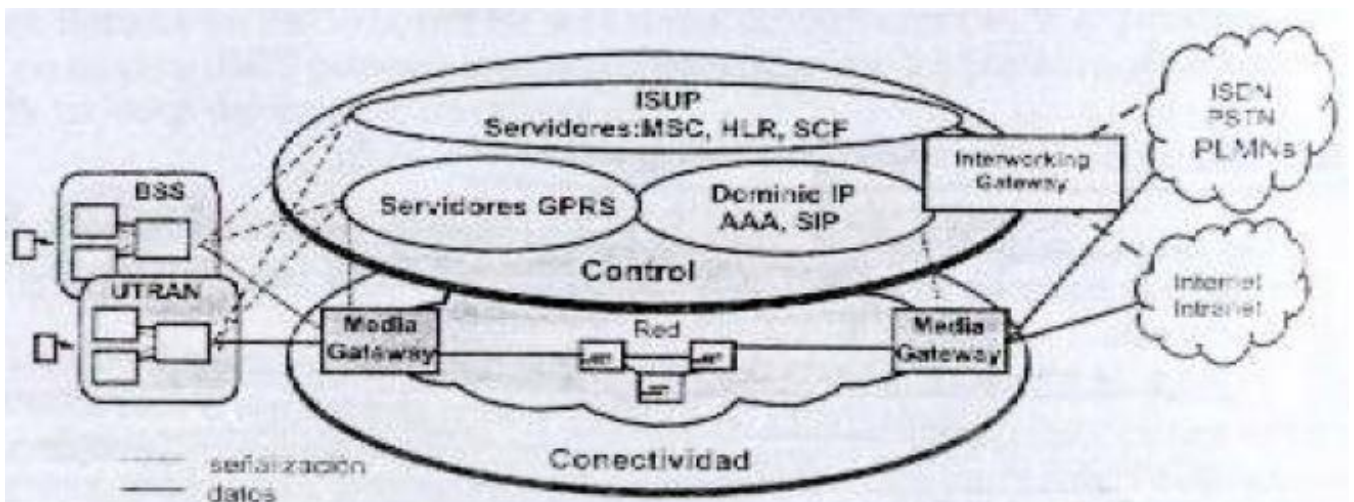

Figure 1.5 Core Network.

In the discontinuous line of the figure it is possible to see the signaling traffic that corresponds to the control level. Inside the control plane the surroundings dedicated to ISUP, GPRS and IP are distinguished. When the development of the network architecture will be All IP, servers ISUP and GPRS will be able to be suppressed.

The applications partially reside in the terminals and these specific servers of applications in the core network.

The core network is constituted by a series of elements (nodes), mentioned some before, that perform different functions. The most important elements are:

- MSC: It handles to the functions of control relative to the services of commutation in way circuit.
- SGSN (*Serving GPRS Support Node*): It handles to the functions of control relative to the services of commutation in packet switching mode.
- AAA (*Authentication Authorization Accounting*): It makes the functions of authentication, security and tarification for the communications in packet switching mode.
- GGSN (*Gateway GPRS Support Node*): It makes the control of the tunnel of data, the handling of directions IP, the collection and exit of the tarification files, the control of the security, route of packets and the management of the quality.
- SCP: It contains the logic of the services of intelligent network, like services of virtual private networks or services of pre-payment.
- EIR: It is a data base that contains the identities and characteristics of the mobile equipment.
- *Billing Gateway*: It collects generated by different nodes (GSN, MSC, etc.) and it directs it to the operator administrator management systems.

Through Core Network, UMTS system is also connected with other telecommunication networks, so that is possible the communication not only between UMTS mobile users.

1.3.1.2. UTRAN

Like other systems of mobile communications, UMTS are identified frequently by their characteristics, originating of the mobile terminals.

The radio access network, i.e., the UMTS Terrestrial Radio Access Network, is called UTRAN.

UMTS has been tried to introduce a certain degree of independence between the radio interface and other parts of the system. This independence partially has been implemented in terms of a logical separation between the UMTS Stratum Access and the Non Stratum Access. The Stratum Access is the set of protocols and capacities that are more closely integrated to the technique of considered radio, whereas the Non Stratum Access is used to denote those that are independent of the access network radio.

Theoretically this allows a system of mobile radio to use different networks from access, releasing to the central network of the chosen particular technology for the access. As a result, several types of access networks can be connected to other mobile radio system.

In order to provide a general vision of the radio access network and to emphasize its innovating aspects based on the specifications 3GPP, we have these three differentiated architectures:

- General architecture of UTRAN.
- Architecture of the UTRAN protocols.
- Architecture of the radio protocols.

The radio access network is managed with two interfaces: The Uu interface that is between UTRAN and the mobile terminals, and the Iu interface which connects UTRAN with the core network.

In fact the last interface develops a double function, integrating the interface of the central network based on circuit switching mode and the interface of the central network based on packet switching mode. The following figure shows the UTRAN structure in detail and two main elements can be observed.

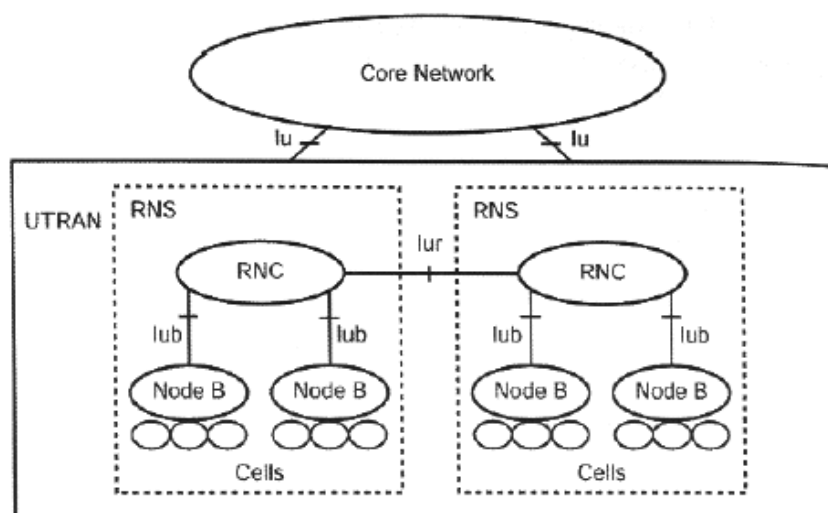

Figure 1.6 UTRAN Structure.

Node B

It is equivalent to BTS (Base Transceiver Station) of GSM. It is in charge of the transmission and the radio reception. Their main functions are codify, modulation, spreading, interleaving, to guarantee the communications quality, to make the internal power control (inner loop), etc. A Node B supervises a set of cells that could be FDD (Frequency Division Duplex) or TDD (Time Division Duplex).

RNC

It is similar to BSC (Base Station Controller) of GSM. It is in charge of the Radio Resources Management. Their main functions are control of the calls or to handover, admission control, congestion control, allocation of codes, etc.

The UMTS radio interface is structured in layers where the logical channels are mappings in transport channels in the MAC layer. A transport channel defines the way in which logical channels are processed and sent to the physical layer. The smaller traffic unit that can be transmitted through a transport channel is called Transport Block (TB). In certain period of time, the so-called Transmission Time Interval (TTI), certain number of Transport Block is sent to the physical layer where certain coding characteristics are introduced, interleaving and rate matching that gives the definition of the Transport Format (TF). We want to emphasize that the transmitted TB number in a TTI determines different TF and are associated to different transmission rates. The network assigns a TF allowed list for each user. This list denominates Transport Format Set (TFS).

1.3.2. Operation Modes

UMTS has two modes of operation: FDD (Frequency Division Duplex) where the uplink and downlink transmissions are done in different frequencies and TDD (Time Division Duplex) where uplink and downlink transmissions are done in different periods of time. The following figure shows a graphical representation of these operation modes.

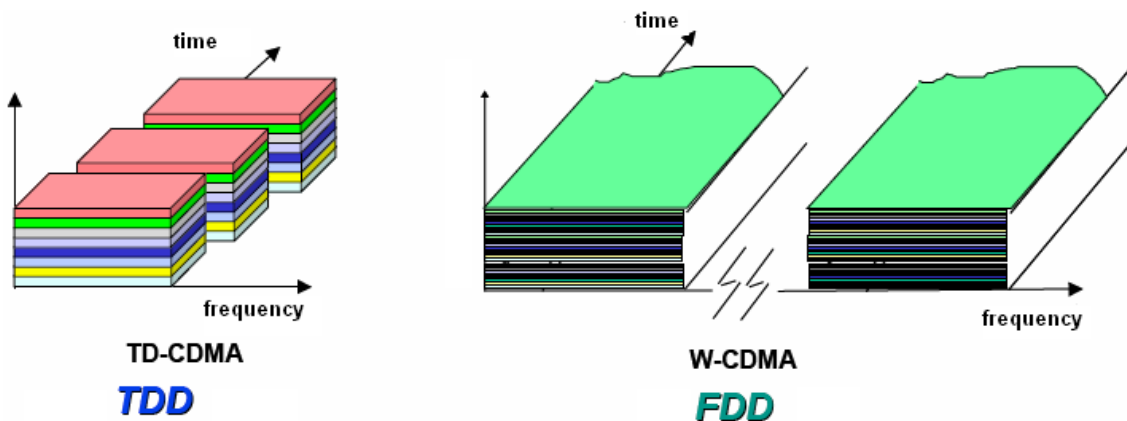

Figure 1.7 WCDMA operation modes.

FDD uses a BPSK modulation in the uplink and a QPSK in the downlink. In Europe: 1920-1980/2110-2170MHz, Total: 60+60 MHz. In this way, the Spanish operators can have three carriers to FDD, 15 + 15 MHz (15 x 4 operators (100% of the band available in Europe)).

TDD uses a scheme of multiple accesses: Hybrid W-CDMA + TDMA. In this case it uses a QPSK modulation in both connections. In Europe: 1900-1920/2010-2025MHz. Total: 20+15 = 35 MHz. The Spanish operators can have 1 carrier for way TDD.

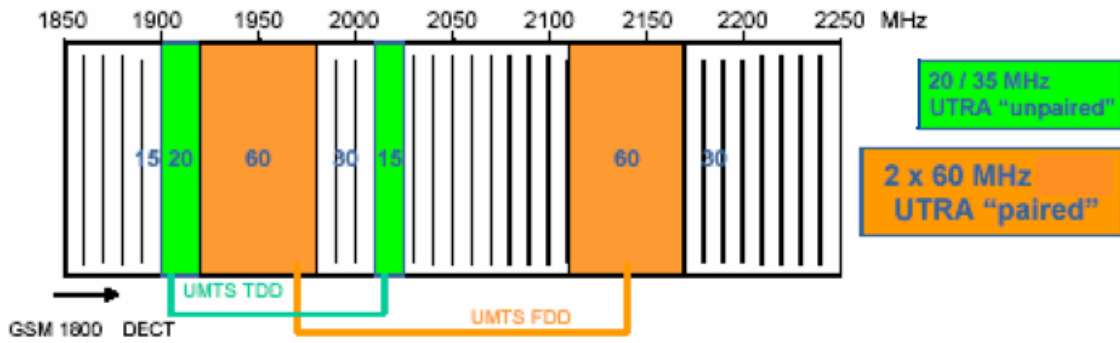

Figure 1.8 Europe frequencies for FDD and TDD.

1.3.3. Quality of Service

In order to provide certain quality of service in a network is necessary to establish from the origin to the destiny a bearer service with characteristics and functionalities defined clearly.

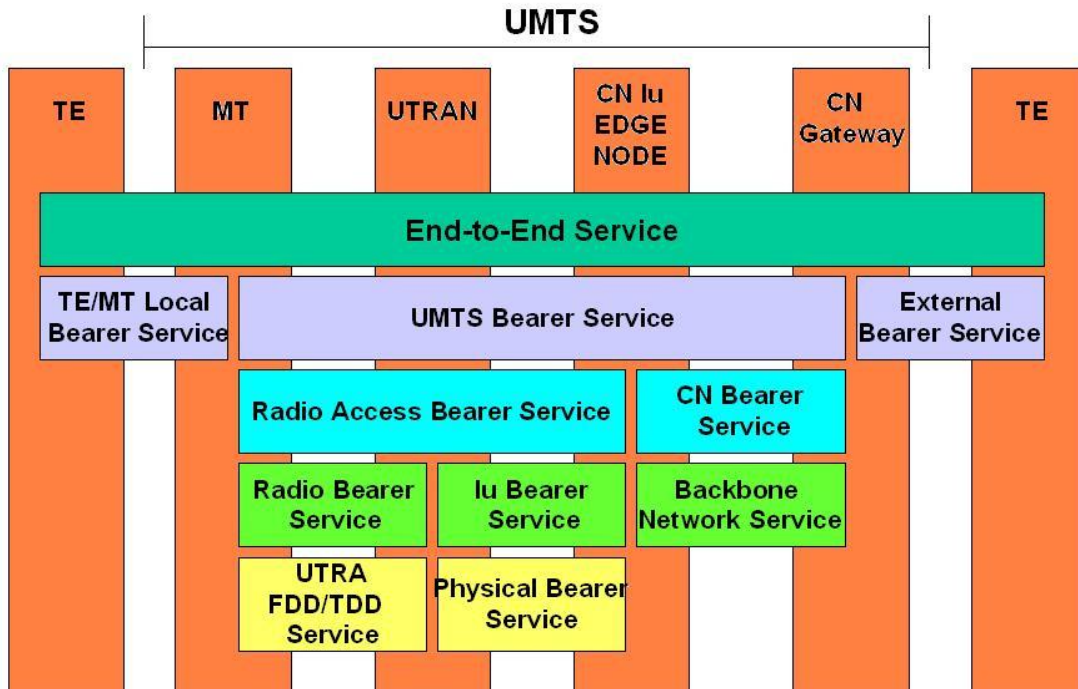

Figure 1.9 Functionalities of QoS management.

The Bearer service will include all the aspects necessary to allow the forecast of the contracted quality. Some of these aspects are, the signaling control, and the transport of the traffics that enter the network from the diverse access and the functionalities of QoS management (Quality of Service).

The Bearer service should have some important parameters:

- Traffic type: this parameter is intended to describe the characteristics of the source.

- Maximum bit rate: this parameter could be used for policing the user traffic.
- Guaranteed bit rate: this parameter would be used for resources reservation. It is used to reserve a given data rate.
- Minimum bit rate: to provide something better than “best effort” in a loaded network / in case of congestion.
- Traffic handling priority: this parameter indicates that the bearer shall have priority over some other bearer in the same traffic type. It will not indicate priorities between traffic types. This parameter can only be considered if you have no delay parameter set. Priorities between traffic types are indicated by the traffic type parameter.
- Bit /packet error ratio: to control the level of errors to make UMTS suitable to the target applications.
- Maximum transfer delay: the maximum time between reception of the last bit of a packet at a UMTS entry point to the delivery of the last bit of the packet at the UMTS exit point.
- Reference packet delay: the transfer delay for a burst comprising of one and only one packet.

UMTS QoS formalization is based on a group of attributes, showed in the next figure. As it can be seen, not all the attributes are applicable to all QoS classes.

	Conversational	Streaming	Interactive	Background
Maximum bitrate	X	X	X	X
Delivery order	X	X	X	X
Maximum SDU size	X	X	X	X
SDU format information	X	X		
SDU error ratio	X	X	X	X
Residual bit error ratio	X	X	X	X
Delivery of erroneous SDUs	X	X	X	X
Transfer delay	X	X		
Guaranteed bit rate	X	X		
Traffic handling priority			X	
Allocation/Retention priority	X	X	X	X

Figure 1.10 QoS attributes defined for UMTS bearer service.

CHAPTER 2. W-CDMA

2.1. History and evolution

The CDMA use for the civil applications of the mobile systems is relatively recent. The spectral spreading technology is the base of CDMA technology, which was specially used in the military applications to resist the effect of hard jamming and to hide the transmitted signal to possible spies.

The great attraction of the CDMA was from the beginning its inherent capacity to increase the benefits of the communications and to reuse frequencies.

The first CDMA networks were commercially launched in 1995, and provided roughly 10 times more capacity than analog networks - far more than TDMA or GSM. Since then, CDMA has become the fastest-growing of all wireless technologies, with over 100 million subscribers worldwide. In addition to supporting more traffic, CDMA brings many other benefits to carriers and consumers, including better voice quality, broader coverage and stronger security.

In 1999, the International Telecommunication Union adopted an industry standard for third-generation (3G) wireless systems that can deliver high-speed data and other new features. The 3G standard includes three operating modes based on CDMA technology.

2.2. CDMA concept

CDMA is a digital transmission technology that allows a number of users to access to a radio frequency channel with a little interference, assigning a different code from each one.

In the communication systems with spread spectrum, the signal bandwidth is expanded, commonly to several orders of magnitude before his transmission. In a multiuser environment, the users can share the same channel and the system gets to be efficient.

2.2.1. Spread Spectrum

In spread spectrum systems, the signal is transmitted on a bandwidth that, often, is greater than it was required for the transmissions standard of narrow band in order to improve the ratio signal noise.

The disadvantage in narrow band systems for telecommunications is the channel capacity limitation. This means that the effective SNR must be sufficiently high so that the receiver can recover the signal transmitted without error.

Spread-spectrum communications is a secondary modulation technique. In a typical spread-spectrum communication system, the message signal is first modulated by traditional amplitude, frequency, or phase techniques. A pseudo-random noise (PN) signal is then applied to spread the modulated waveform over a relatively wide bandwidth. The PN signal can amplitude modulate the message waveform to generate direct-sequence spreading, or it can shift the carrier frequency of the message signal to produce frequency-hopped spreading as show in figure 2.1.

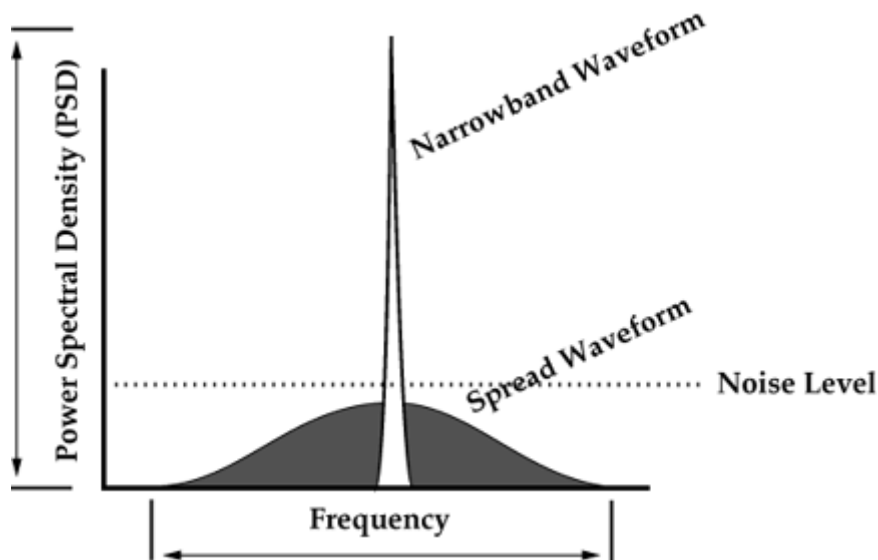

Figure 2.1 Original and spread signal difference.

The direct-sequence spread-spectrum signal is generated by multiplying the message signal $d(t)$ by a pseudo-random noise signal $pn(t)$:

$$g(t) = pn(t) \cdot d(t) \quad (2.1)$$

In most cases, the PN signal is a very high rate nonreturn-to-zero (NRZ) pseudo-random sequence that chops the modulated message waveform into chips, as shown in figure 2.2. The rate of the secondary modulating waveform is called the chip rate, R_c , while the rate of the messages signal is designated the bit rate, R_b . The two modulation processes produce different bandwidths; note that the secondary modulation does not increase the overall power of the message signal but merely spreads it over a wider bandwidth.

The frequency-hopped spread-spectrum signal is formed by multiplying the message signal with a pseudo-random carrier frequency $\omega_{pn}(t)$:

$$g(t) = \cos[\omega_{pn}(t) \cdot t] \cdot d(t) \quad (2.2)$$

Spread-spectrum modulation techniques provide powerful advantages to communication systems, such as a flexible multiple-access method and interference suppression. These advantages are examined here for direct-sequence spread-spectrum signals.

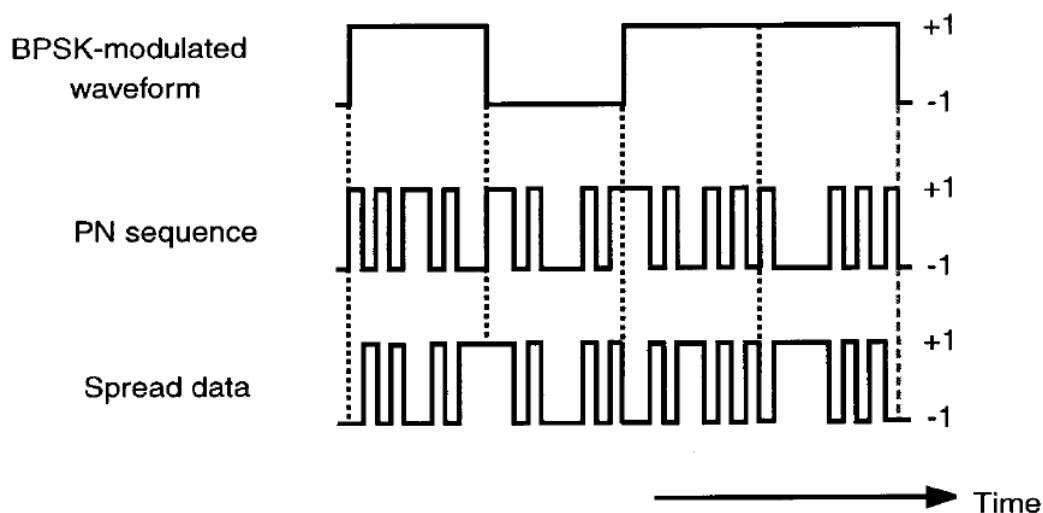

Figure 2.2 Direct-sequence spread-spectrum signals.

2.2.2. W-CDMA system

WCDMA (Wideband Code Division Multiple Access) is a 3G mobile network technology that is used in Europe in the new IMT-2000 frequency bands.

WCDMA was designed to provide efficient capacity for modern mobile multimedia applications and mobile telephone services.

WCDMA have bandwidth around 5 MHz. This wide bandwidth supports high data transfer rates and also provides performance benefits due to the diversity of broadcast frequency achieved. In addition, a new technology called HSDPA will bring even higher downlink speeds over WCDMA radio access networks.

The benefits of WCDMA are:

- Faster, more efficient and more flexible service for data transmission.
- Designed to support simultaneous services with different service quality requirements in terms of throughput, transfer delay, and bit error rate.
- A global technology with nearly universal adoption.

A code is used to modulate the transmit signal. This code consists of a binary impulses series or Chips, known like a pseudo-noise sequence (PN) that is a binary sequence with a certain period. The code is executed a higher rate than the signal to transmit. It determines the real bandwidth of transmission.

The narrow band communications cause little or no interference in systems W-CDMA because the correlation receiver is integrated on full bandwidth to recover a signal W-CDMA.

CHAPTER 3. Radio Resources Management

3.1. Introduction

This chapter is organized in the following way: first we detail the Radio Resources Management strategies and then some algorithms.

3.2. RRM Strategies

The radio interface capacity optimization is carried out by means of Radio Resources Management algorithms that consider the mean levels of interference in the system. These algorithms are the admission control, the congestion control (load control), the power control, handover and the suitable transport format management. The next figure shows the typical locations of some RRM functionalities.

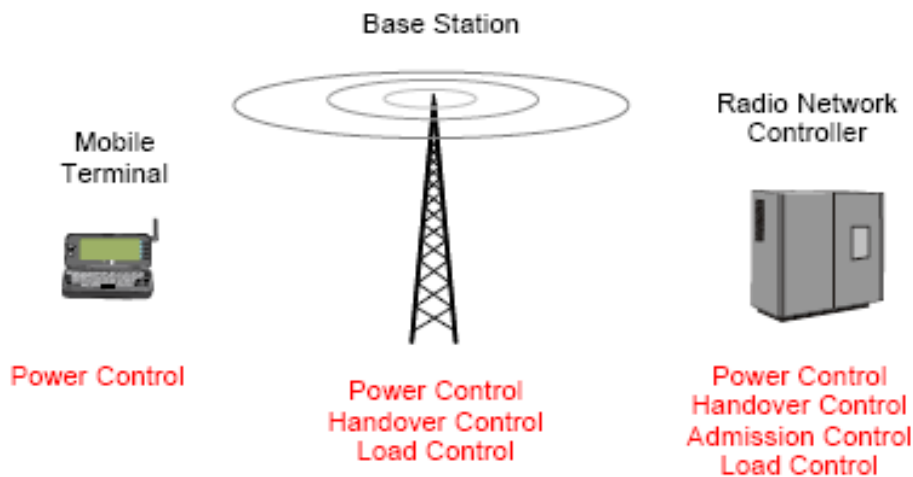

Figure 3.1 Typical locations of some RRM functionalities.

Admission Control

The admission control is the algorithm that determines if a connection request must be accepted or be rejected. It is based on the interference that adds a new user if he will be accepted, to the already existing connections. Therefore, it is responsible to decide if new RAB (Radio Access Bearer) can be established and which the allowed TFS is. The considered admission control makes use of the load factor and the load increase estimation that generates in the radio network the establishment of the connection request. The strategies of admission control can be classified as modeling-based or statistic-based.

In case the load factor η in the air interface is considered in statistical terms, and assuming K users admitted in the system, the cell must verify next formulation for all users:

$$\eta = (1+f) \sum_{i=1}^K \frac{1}{\frac{SF_i}{v_i \cdot \left(\frac{E_b}{N_o}\right)_i \cdot r} + 1} + (1+f) \frac{1}{\frac{SF_{K+1}}{v_{K+1} \cdot \left(\frac{E_b}{N_o}\right)_{K+1} \cdot r} + 1} < \eta_{Th} \quad (3.1)$$

Where η_{Th} is the admission threshold, SF_i is the spreading factor, that is to say, the admission average TF considered by the base station, with which the terminal is expected to transmit, (E_b/N_o) is the quality required for the i -th user and r is the coding rate. The power of intercellular interference has been modeled like a proportional factor, factor f , of the power of intracellular interference.

The admission control of our simulator is based on the previous formulation.

Congestion Control

The congestion control must act when the admitted users cannot satisfy the quality requirements during certain time period due to an overload in the radio network.

The congestion control mechanisms of include the following parts:

1. Congestion detection: Some criteria is necessary to be established to decide if the network is in congestion or not. A possible criterion to detect when the system has entered a congestion situation is when the load factor is higher than certain threshold ($\eta \geq \eta_{CD}$) during certain period of time ΔT_{CD} .
2. Congestion resolution: When congestion in the network is assumed, certain actions are necessary to carry out to maintain the stability in the network. The congestion resolution algorithm takes certain actions to try to solve these situations. Multiple possibilities to carry out this resolution of the congestion exist, but in general, three steps can be differentiated:
 - 2.1. Prioritization: The different users are ordered themselves in a table beginning by the one of low priority until the one of higher priority. It is assumed that all the interactive users have the same quality requirements. Therefore, the prioritization consists on the users that are transmitting with high rates giving to minor priority of transmission. Therefore, the users will be ordered in the table of low to higher processing gain.
 - 2.2. Load reduction: Mainly two actions are necessary to make:
 - a) During the congestion, any connection request is not accepted.

b) The TFS (i.e., maximum transmission rate is limited) of certain number of users already admitted in the network is reduced, beginning by the less priority user of the table of priorities. In the considered congestion control, the selected users it is not allowed them to transmit during the congestion period (i.e., their TFS is limited until TF0).

2.3. Load control: After carrying out point b), is necessary to return to verify the condition that activates or deactivates the congestion control. If the congestion persists, it is necessary to return to section 2, limiting the TFS of the following user group of the prioritization table. It is considered that the congestion has been solved if the load factor is lower than certain threshold $\eta \leq \eta_{CR}$ during certain period of time ΔTCR .

3. Congestion recovery: A congestion recovery algorithm is necessary to recover the transmission parameters that the users had before the congestion. It is necessary to emphasize that this section is crucial since depending on how the recovery is carried out the system could return to fall in congestion. An user by user recovery mechanism has been considered, this is, in the first place the user 's TFS is increased and when this user has completed the transmission in course, the TFS of the following user is increased.

Power Control

The power control works in order to assign the powers that each user must transmit for the uplink and the downlink or.

This control is a mechanism to assure the connection quality and it is a basic component in the Radio Resources Management.

In particular the power control in UMTS is used for:

- In order to diminish or to increase the transmission power of the mobile based on the distance.
- In order to reduce interferences.
- In order to maximize the batteries duration.

In UMTS, two processes for the power control are defined simultaneously:

- *Outer loop*: The external power control has the mission to dynamically establish the E_b/N_0 necessary value to assure the communication quality. I.e., UTRAN evaluates the real quality values and it resists them with the required ones. The possible deviations are corrected with small variations of E_b/N_0 .
- *Inner loop*: This control works to 1500Hz. To this frequency the fadings at small or moderate bit rate can be corrected.

Handover

Handover is referred when a mobile terminal is connected to a base station and comes in a cell which another base station gives coverage, and it is necessary to do a new radio link with the new base station.

One of the most excellent advantages of UMTS technology is, the implementation of the Soft Handover. Soft H.O. is the possibility that has terminal or UE (User Equipment) to be connected to more than a base simultaneously, i.e., that the radio links are added and removed in a way that the UE always keeps at least one radio link to the UTRAN. Soft handover is performed by means of macro diversity, which refers to the condition that several radio links are active at the same time. Normally soft handover can be used when cells operated on the same frequency are changed.

So, some of the problems that are presented in GSM can appear, among others, microcuts and the denominated “corner effect” (when a terminal turns in a corner and has not direct line of sight with a base server. The attenuation introduced by the building makes very complicated the communication and the crossing manage is not possible).

The set of bases with which a certain terminal is connected is the denominated Active Set and will be necessary to define a mechanism that serves to determine to which bases the UE will be connected.

In UMTS two classes of handover are specified: Soft Handover and a special case denominated Softer Handover (figure 3.1). In the first case the terminal is connected simultaneously to different cells from different nodes B. In this case the RNC will be the one in charge to select the best one of the two signals (combination by selection). On the other hand, in softer the signal of the terminal is received in cells of a same location and the received power of both ways is combined (strategy MRC).

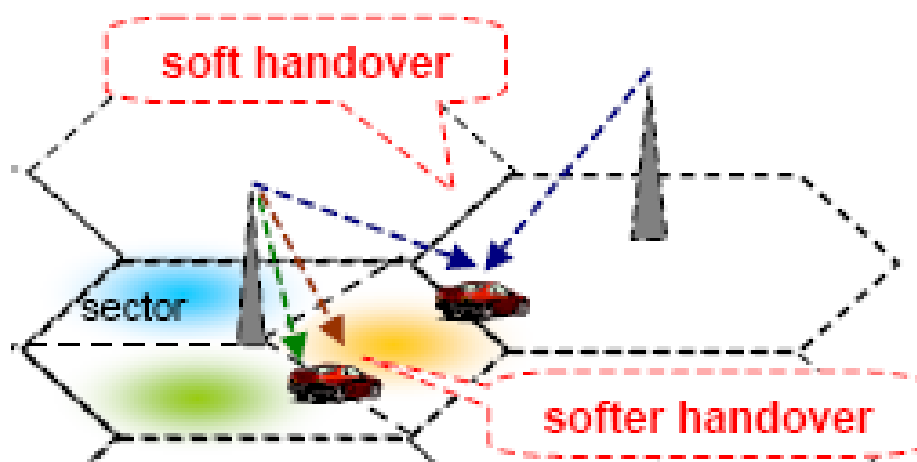

Figure 3.2 Soft Handover (left) and Softer Handover (right)

Transport format Management

This strategy is in charge of the short term decisions for the more suitable transmission rate in every moment. In our case, the uplink case, the decision is taking of decentralized and centralized way in each one of the mobiles, whereas in the downlink the operation is centralized, the decisions are based on the global necessities.

For the uplink case, this process is done in two phases:

- Centralized component, located in the Radio Network Controller where it is carried out the congestion control.
- Decentralized component (located in the mobile terminal MAC layer). This algorithm independently decides a TF within the TFS in each TTI.

For the interactive users, there are two specific algorithms considered in this project (in fact, there are much more algorithms):

- **Maximum Rate Algorithm (MR)**

It consists on selecting the TF that allows the user to transmit with the maximum rate. So, the transport blocks number that will be transmitted in a TTI would be:

$$numTB = \min \left(TB_{max}, \left\lceil \frac{L_b}{TBsize} \right\rceil \right) \quad (3.2)$$

Being TBmax the maximum number of the transport blocks (TB) that can be transmitted by TTI and TBsize the number of bits by transport block (TB).

- **Service credit Algorithm (SCr)**

When certain bit rate must be guaranteed, a new possibility appears making use of the service credit concept (SCr). The SCr of a connection considers the difference between the obtained bit rate (measured like TB by TTI) and the expected bit rate for that connection. Essentially, if SCr>0 the connection has obtained a greater bit rate than an expected one, if SCr<0 the connection has obtained an expected smaller bit rate one. At the beginning of the connection: SCr(0)=0. In each TTI, the SCr for a connection should be:

$$SCr(n) = SCr(n-1) + \left(\frac{Guaranteed_rate}{TB_size} \right) - Transmitted_TB(n-1) \quad (3.3)$$

where $SCr(n)$ is the Service Credit for $TTI=n$, $SCr(n-1)$ is the Service Credit of previous TTI, $Guaranteed_rate$ is the bits numbers per TTI that should be transmitted for the guaranteed bit rate, TB_size is the bits number of the Transport Block for the considered RAB, $Transmitted_TB(n-1)$ is the number of well send Transport Blocks in the previous TTI.

The $Guaranteed_rate/TB_size$ reflects the number of Transport Block that is due to transmit by TTI to maintain the guaranteed bit rate. Consequently, $SCr(n)$ indicates the number of Transport Block that the connection must transmit in the present TTI. For example, if the bits $TB_size=240$, the $Guaranteed_rate=24$ Kb/s, and $TTI=20$, the UE each TTI adds 2 credits of the service.

Then, knowing that in the buffer there is L_b bits, the number Transport Blocks has to transmit in a $TTI=n$ will be:

$$numTB = \min\left(\left\lceil \frac{L_b}{TBsize} \right\rceil, SCr(n), TBmax\right) \quad (3.4)$$

CHAPTER 4. Analysis of the Cell Coverage

4.1. Introduction

After explaining the main elements of the radio resource management strategies, this chapter is focused on analyzing and determine the most important parameters the may affect the cell coverage.

4.2. Formulation

In the uplink of a WCDMA cell, all users share the common bandwidth and each new accepted connection increases the interference level to the rest of the connections, affecting their quality expressed in terms of E_b/N_o . For M simultaneous users transmitting in a given frame, the following equation must be satisfied by the i -th user:

$$\frac{P_i \cdot \frac{W}{R_{b,i}}}{P_N + \chi + [P_R - P_i]} \geq \left(\frac{E_b}{N_o} \right)_i \quad i=1 \dots M \quad (4.1)$$

$$P_R = \sum_{i=1}^M P_i$$

where P_i denotes the i -th user received power at the base station, $R_{b,i}$ is the i -th user bit rate, P_N is the background noise and $(E_b/N_o)_i$ stands for the i -th user requirement. W is the total bandwidth after spreading, P_R is the total receiver own-cell power at the base station and χ represents the intercellular (other-cell) interference. From equation (4.1), the required received power level for the i -th user can be determined:

$$P_i \geq \frac{P_N + \chi + P_R}{\frac{W}{\left(\frac{E_b}{N_o} \right)_i R_{b,i}} + 1} \quad i=1 \dots M \quad (4.2)$$

Adding all the M equations from equation (4.2):

$$\sum_{i=1}^M P_i = P_R \geq \sum_{i=1}^M \frac{P_N + \chi + P_R}{\frac{W}{\left(\frac{E_b}{N_o} \right)_i R_{b,i}} + 1} \quad (4.3)$$

Taking into account (4.3), P_R can be expressed as:

$$P_R \geq \frac{(P_N + \chi) \sum_{i=1}^M \frac{1}{\frac{W}{\left(\frac{E_b}{N_o}\right)_i R_{b,i}} + 1}}{1 - \sum_{i=1}^M \frac{1}{\frac{W}{\left(\frac{E_b}{N_o}\right)_i R_{b,i}} + 1}} \Rightarrow P_R = \frac{(P_N + \chi) \sum_{i=1}^M \frac{1}{\frac{W}{\left(\frac{E_b}{N_o}\right)_i R_{b,i}} + 1}}{1 - \sum_{i=1}^M \frac{1}{\frac{W}{\left(\frac{E_b}{N_o}\right)_i R_{b,i}} + 1}} \quad (4.4)$$

where the equality has been imposed in order to consider the minimum required power. Taking into account that $P_N > 0$ from equation (4.4) it can be obtained that:

$$\left(1 + \frac{\chi}{P_R}\right) \sum_{i=1}^M \frac{1}{\frac{W}{\left(\frac{E_b}{N_o}\right)_i R_{b,i}} + 1} < 1 \quad (4.5)$$

Expression (4.5) leads to the definition of the load factor as shown in equation (4.6). The load factor measures the theoretical spectral efficiency in a WCDMA cell.

$$\eta_{UL} = \left(1 + \frac{\chi}{P_R}\right) \sum_{i=1}^M \frac{1}{\frac{W}{\left(\frac{E_b}{N_o}\right)_i R_{b,i}} + 1} = \frac{P_R + \chi}{P_R + \chi + P_N} \quad (4.6)$$

The uplink cell load factor η_{UL} , is used in WCDMA to measure the cell efficiency. Taking into account (4.4) and (4.6), the required transmitted power by a single UE (User Equipment) in the cell in order to achieve the target quality level is:

$$P_T = \frac{L_p(r) \cdot P_N}{\left(\frac{W}{\left(\frac{E_b}{N_o}\right)_i R_{b,i}} + 1\right) (1 - \eta_{UL})} \quad (4.7)$$

where $L_p(r)$ denotes the path loss between the user equipment and the Base Station at distance r . Clearly in (4.7), as the cell load factor η_{UL} increases the required transmitted power also increases. This causes the well-known effect of cell breathing, so when the cell load factor is increased, users which suffer high path loss may not have enough power to satisfy the E_b/N_o target and

consequently, the coverage area is reduced. Then, given a maximum mobile transmitted power P_{Tmax} , the higher the load factor is, the lower the maximum tolerable path loss $L_{pmax}(r)$ will be in order to guarantee the E_b/N_o target.

From the point of view of quality requirements, a user is said to be in outage when it is not able to achieve the E_b/N_o target, for a given load factor η_{UL} . Then, taking into account equation (4.7):

$$L_{pmax}(r) < \frac{P_{Tmax}}{P_N} \cdot \left(\frac{W / R_{b,i}}{(E_b / N_o)_i} + 1 \right) \cdot (1 - \eta_{UL}) \tag{4.8}$$

From (4.8) and with the next values:

- $W=3'84 \cdot 10^6$
- $E_b/N_o=1.96$ dB.
- $P_N=-103$ dBm.
- $P_{Tmax}=21$ dBm,

we can obtain the following graph for different bit rate values:

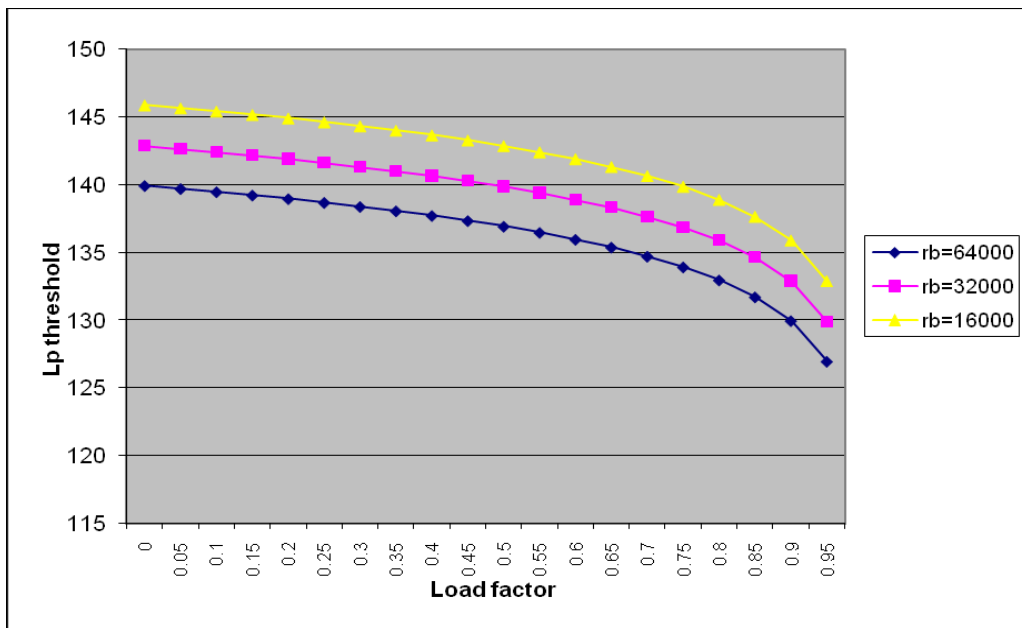

Figure 4.1. Graph Lp based on Load factor.

This graph shows the Path Loss based on load factor. We can see three different colors that indicate three different Rb values. For the three cases we can observe that as the load factor increases the value of Path Loss decreases.

Another important fact of this graph is the Path Loss behavior at high Load factor values. As we have said before, this happens because a higher Load factor will do lower the following parameter $(1 - \eta_{UL})$ and therefore the value of Lp diminishes when the load factor is growing.

After we can see this important relation, we should obtain the expression of the maximum distance in function of the load factor, because the Path Loss depends on the distance.

If we know that the Path Loss can be calculated with the next expression:

$$L_{p\max} (dB) = L_o + \gamma \cdot \log_{10}(d) + S(dB) \tag{4.9}$$

Where L (dB) is the attenuation, d is the distance between the mobile and base station (in meters) and S (dB) is the slow fading (shadowing).

So, the distance in meters, can be expressed as:

$$d(m) = 10^{\frac{L_{p\max} (dB) - L_o - S(dB)}{\gamma}} \tag{4.10}$$

According to 4.8 and 4.10:

$$d(m) = 10^{\frac{\left[\frac{P_T \max}{P_N} \cdot \left(\frac{W / R_{b,i}}{(E_b / N_o)_i} + 1 \right) \cdot (1 - \eta_{UL}) \right] - L_o - S(dB)}{\gamma}} \tag{4.11}$$

With these changes we have obtained an expression of the maximum distance as a function of the load factor. So we have the same case, when load factor increases the maximum distance decreases, as the path loss.

For the next values, we can obtain the graph shown in figure 4.2:

- $L_o = 128.1$ dB
- $\gamma = 37.6$
- $S = 8$ dB

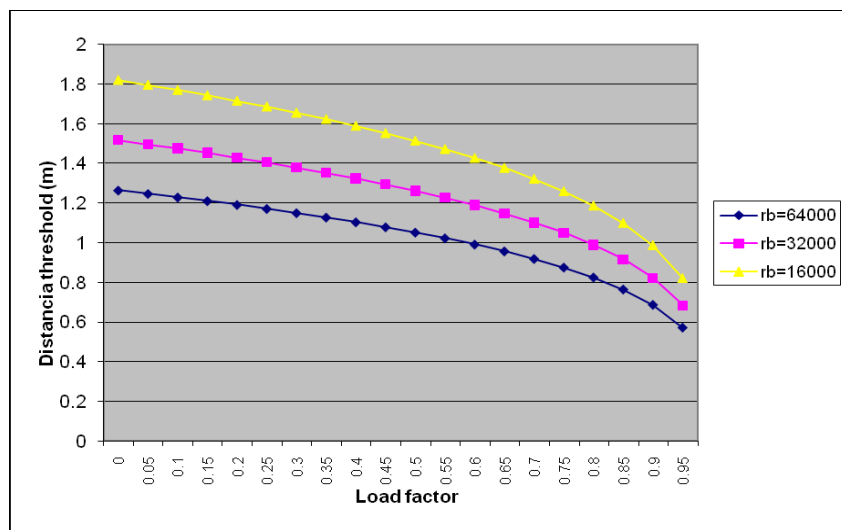

Figure 4.2. Graph Distance in function of Load factor.

The last graph demonstrates the effect named cell breathing, i.e., when the load factor increases, the coverage area decreases.

Notice that, on one hand, according to equation 4.6, the user bit rate has an important impact on the load factor (or equivalently, the level of interference). Therefore, by reducing the bit rate of certain users, a reduction in the load factor can be obtained (this is one of the fundamentals of congestion control strategies). On the other hand, it is worth noting that according to figure 4.1, for certain level of load factor, a reduction in the user bit rate may increase the margin of path loss in order not to fall in outage (i.e. if we consider a user located far from the base station in a cell with certain load factor, the higher the user bit rate is, the higher the outage probability will be. Therefore, in order to assure coverage for certain users which suffer high path loss a reduction in the user bit rate may be a possible solution. This bit rate reduction can be translated into a lower path loss restriction or equivalently an increase in the coverage area for this user as depicted in figure 4.2.

4.3. Proposed bit rate reduction algorithm

According to the dependence of the cell coverage and the user bit rate, shown in figure 4.2, this section proposes a new TF selection algorithm in order to reduce the dropping rate.

With the proposed strategy, users located far from the Base Station (which may have coverage problem) will reduce its maximum TF in order to maintain the user coverage.

Note that the TF reduction provides a bit rate reduction which will reduce the UE power limitation probability and consequently the dropping rate.

The idea is continuing work with the Maximum Rate algorithm, concentrating on the interaction study that has the interactive users in the system. The new implementation is to try not to lose those users that are at the cell coverage border.

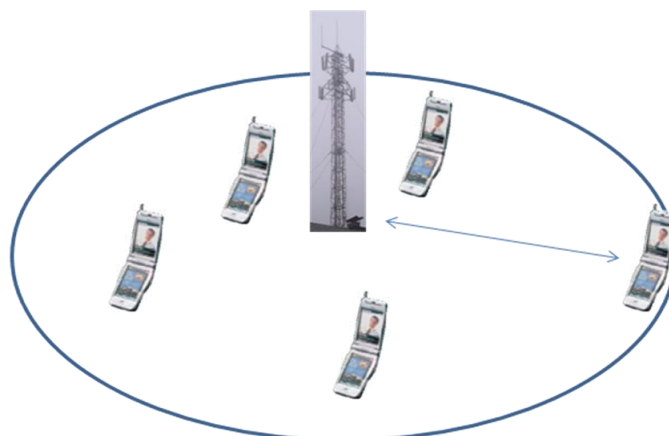

Figure 4.3. Analyzed Situation.

The condition improvement consists of do that the WWW users that are in the cell coverage border check that their transmitted power is higher than the maximum transmitted power minus an increment. This increment is an input parameter and it can be modified:

$$P_T > P_{T,m\acute{a}x} - \Delta(db) \tag{4.12}$$

If during a certain number of frames this condition is checked for the same user, we will down the user's TF. The frames time, i.e., the time during a frame has made more than once.

When considering the MR algorithm, the most frequently used TFC is TF4. The proposed algorithm reduces the maximum TFC as shown in figure 4.4:

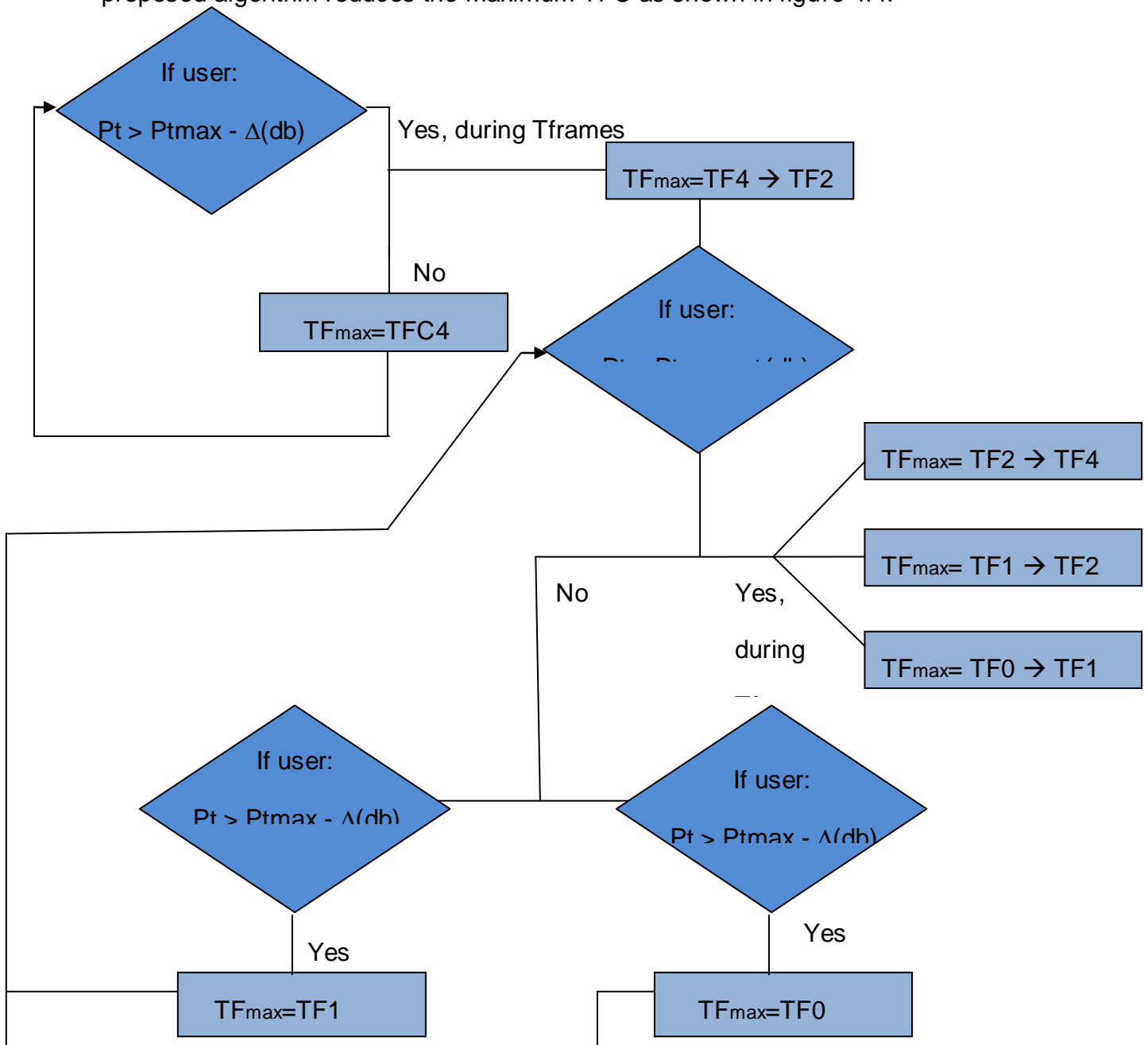

Figure 4.4 Proposed bit rate reduction algorithm scheme.

In this way, we think that there will be less droppings in the system, at price to limit the transmitted rate if it required.

Once the limited user has his transmitted power like:

$$P_T < P_{T,m\acute{a}x} - \Delta(db) \quad (4.13)$$

we increase his TF to TF4. So, this user can restore his TF to transmit at the maximum rate without cell coverage problems.

But if the problem persists in some more frames (T+50) the user's transport format will be decrease to TF1. If with this decrease the user improves his transmitted power, his TF will increase to TF2. But if the situation does not improve, another TF decreased will be necessary, this time to TF0. And like in the other case, if with this implementation the user recovers his good situation, his TF will increase to TF1.

The advantage that will have this new algorithm is to have fewer droppings, and if we observed the obtained results in chapter 6, the droppings are removed. It is important to the interactive users do not lose the connection.

But there is some disadvantage, like the algorithm fairness because it reduces the TF of some users, meanwhile there are others that always transmit to TF4. The users that always transmit to TF4 are near the base station.

CHAPTER 5. Simulator

5.1. Simulator

5.1.1. System Simulator and Connection Simulator

The study by simulation of a cellular communications system is extremely complex and requires very high computation times if it is tried to incorporate a realistic simulation model in which is considered many of the effects that take place in environment radio mobile.

First, the signal aspects require to work at chips samples level (in case W-CDMA the chip duration is 260ns), meanwhile the mobility and traffic aspects require simulations of order of magnitude of minutes. For that reason we can have the simulations at two levels:

1. Connection Simulation, to consider the aspects of the physical and link layer (code, link, synchronization, etc.). In this simulation a single cell is considered, a single user and the effect of the other users are modeled like noise.
2. System Simulation, to consider the higher layers aspects (MAC protocol, RRM algorithms, mobility, traffic, etc.). In this simulation the presence of several cells with several users in them who can have different services.

The simulations have been carried out in a system simulator. This simulator allows us to have a control of the all terminals position, the transmitted power levels by all users, the transmission rate that each user is applying, the traffic model for each service, etc. For the evaluation of RRM algorithms is important to have dynamic simulators system level, in order that the temporary evolution can be observed before the different management strategies to study.

Next the dynamic system simulator model UTRA-FDD is described that permits the study, evaluation and comparison of different RRM strategies. This system simulator is fed on the results that any connection simulator in form of curves of error rate based on E_b/N_0 values. The E_b/N_0 required for a certain connection is the $(E_b/N_0)_{\text{target}}$.

The inputs of the system simulator are mainly the characteristics of the scene to evaluate: number and position of the base stations, number of users of each class, RRM algorithms parameters that are tried to evaluate in the simulations.

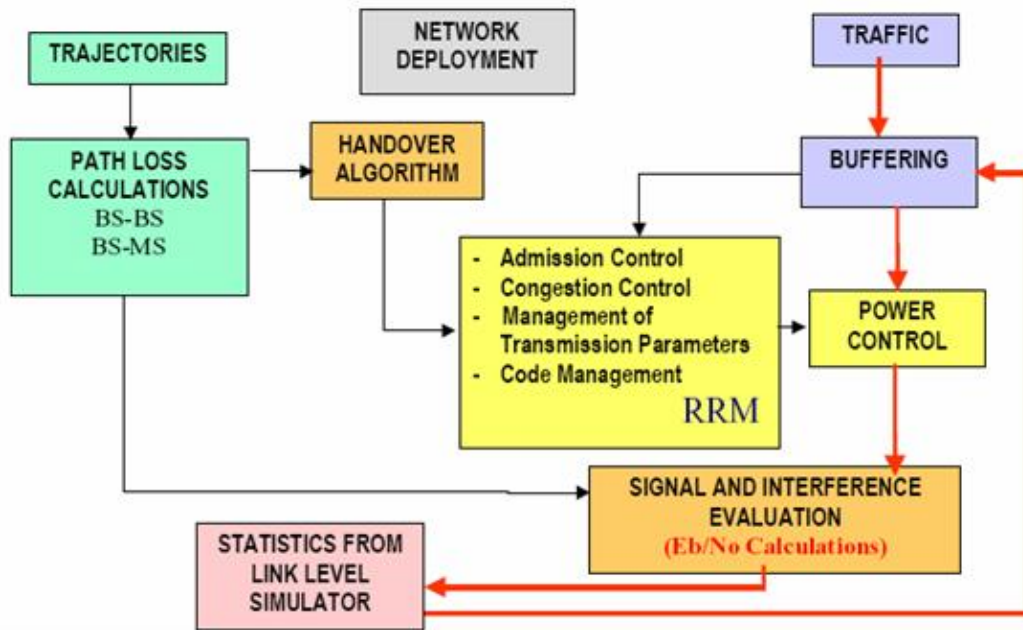

Figure 5.1 Block diagram of the simulator.

From the functional point of view, figure 5.1 shows the procedures involved in the simulator. Initially, the module “Network deployment” allows locating the bases stations and the mobiles.

Module RRM is the central element of the simulator, since it is the part in charge to carry out different RRM strategies. This module acts according to the behavior of the mobile terminals as far as generation of traffic and mobility. The models of traffic generation produce packets according to the type of user and they stay in a buffer before its transmission.

Table 5.1 as a function shows the Eb/No, the BLER for the interactive service for the different TF.

Table 5.1 BLER for the interactive service.

EbNo	BLER (TF4)	BLER (TF3)	BLER (TF2)	BLER (TF1)
-4	$5.72 \cdot 10^{-1}$	$5.72 \cdot 10^{-1}$	$3.43 \cdot 10^{-1}$	$3.43 \cdot 10^{-1}$
-3.8	$3.06 \cdot 10^{-1}$	$3.06 \cdot 10^{-1}$	$2.34 \cdot 10^{-1}$	$2.34 \cdot 10^{-1}$
-3.6	$1.70 \cdot 10^{-1}$	$1.70 \cdot 10^{-1}$	$1.17 \cdot 10^{-1}$	$1.17 \cdot 10^{-1}$
-3.4	$9.50 \cdot 10^{-2}$	$9.50 \cdot 10^{-2}$	$4.92 \cdot 10^{-2}$	$4.92 \cdot 10^{-2}$
-3.2	$2.53 \cdot 10^{-2}$	$2.53 \cdot 10^{-2}$	$1.81 \cdot 10^{-2}$	$1.81 \cdot 10^{-2}$
-3	$5.49 \cdot 10^{-3}$	$5.49 \cdot 10^{-3}$	$6.70 \cdot 10^{-3}$	$6.70 \cdot 10^{-3}$
-2.8	$5.13 \cdot 10^{-3}$	$5.13 \cdot 10^{-3}$	$1.02 \cdot 10^{-3}$	$1.02 \cdot 10^{-3}$
-2.6	$2.03 \cdot 10^{-4}$	$2.03 \cdot 10^{-4}$	$2.03 \cdot 10^{-4}$	$2.03 \cdot 10^{-4}$
-2.4	0	0	0	0

Obviously for a determined E_b/N_0 , the BLER depends on the used TF.

After seeing in general terms the used simulator, we are going to explain traffic models that have been used and a brief description of the Radio Bearer Access considered.

5.1.2. Traffic Model

Web Service Model (interactive):

The interactive service is characterized to have transmission information and delay periods throughout a connection. A clear example of an interactive service is the Web service.

For a certain user, there is a session time period (in which it is connected) and a period of time between sessions (in that it is disconnected). The average time of session divided by the total time, is named activity factor at session level. This time determines the percentage of the time (in average) that a user is connected.

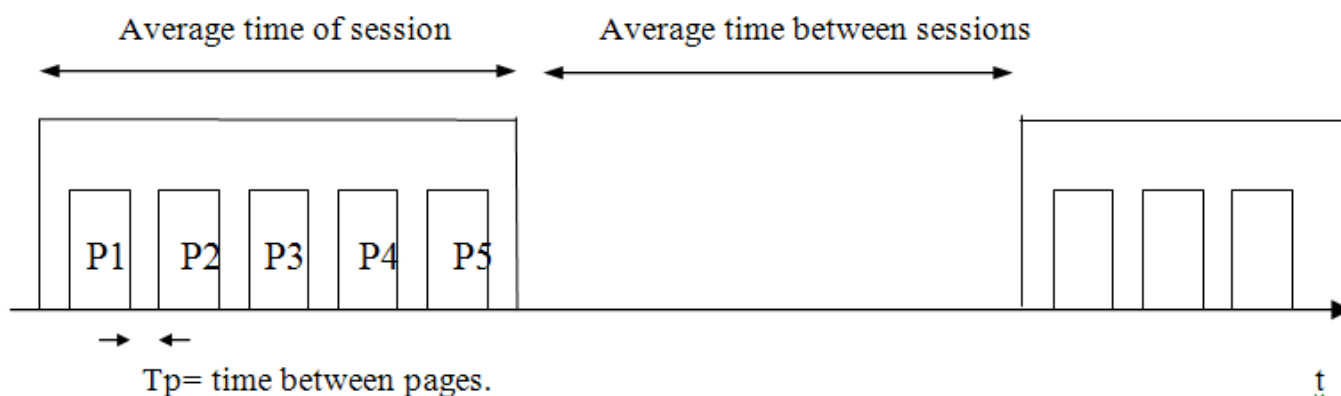

Figure 5.2 Web service diagram.

Within a session, there will be periods in which a user will be downloading information (it will be receiving pages) and periods in which it will be reading the selected information (reading Time).

Each session is formed by a determined number of pages. The time in which a user is transmitting or receiving information divided by the session time receives the name of *activity factor at page level*.

As well, each page is created by certain number of packets. The average time between packets is considered 0.125s. In table 5.2 are the main parameters of this model.

Table 5.2 Web Service Parameters

Parameters	Value
Average time between packets (T_{paq})	0.125 s
Average time between pages (T_{pag})	30 s
Average time between sessions ($T_{\text{between sessions}}$)	300 s
Average number of packets per page (N_{paq})	25
Number of pages per session (N_{pag})	5
Activity factor at session level (v_{session})	0.355
Activity factor at level of page during a session (v_{page})	0.11

5.1.3. Radio Access Bearer (RAB) description

In this section we will detail the typical radio transmission parameters for the interactive service, in addition to the necessary parameters of input to the simulator. In this project a study of the uplink is made, for that reason only appear the transmission parameters characteristics for the uplink and only for the web service.

Choosing a TF within the TFCS¹, the information transmission rate can be controlled. The congestion resolution algorithms will be based on limiting the TFCS available for a RAB. This will cause that the maximum transmission rate of this RAB is limited. So, the level of global interference will be minor. Therefore, the congestion situation will be resolved at the cost of limiting the transmission rate of the certain users.

The main transmission parameters for the interactive service in uplink appear in table 5.3. It is possible to emphasize that the TF3 and the TF4 have the same spreading factor but different transmission rate. In table 5.4 the TFCS can be seen.

Table 5.3 Transmission Parameters for the interactive service (UL)

Parameters		Value
Type TRC		DCH
Size TB		336 bit (320 useful, 16 header)
TFS	TF0	0 × 336 bits
	TF1	1 × 336 bits (16 kbps, SF=64)
	TF2	2 × 336 bits (32 kbps, SF=32)
	TF3	3 × 336 bits (48 kbps, SF=16)
	TF4	4 × 336 bits (64 kbps, SF=16)
TTI		20 ms
Code		Turbo Codes (t 1/3)
CRC		16 bits
N ^o max bits/TTI after channel Code		4236
N ^o max bits/trm before rate matching		2118

¹ Transport Format Combination Set: it decides the maximum load that the RAB causes at the system.

Table 5.4 TFCS for interactive service (UL)

Parameters	Value
Size TFCS	5
TFCS	(64 kbps RAB) TF0, TF1, TF2, TF3, TF4

The main simulator parameters are presented in the next table:

Table 5.5 More useful input parameters.

Parameters	Value
Simulation duration	1000000 frames
Size of the radius of the cell	500
Type of link UL=0 DL=1	0
Orthogonal Factor	1
Intercell Factor	0,6
Strategy UE-MAC for WWW	MR=2
Number of cells (1,7,19)	1
Maximum Power MS	21 dBm
Minimum Power MS	-100 dBm
Increment	1 dB
Admission	1 (admission control activated)
Num frames to activate congestion	10
Num frames to remove congestion	10
Num frames to deactivate	100
Num frames with EbNo under target for doing drooping	200
Num frames condition power	100
Admission TFC for WWW	2 (TF2) o 4 (TF4)
Admission Threshold WWW (η_{WWW})	0,75 / 0,8 / 0,9
Congestion	0 (congest. control deactivated)

5.2. Considered system model

The system simulation model used in this project considers a RAB that provides services of interactive class with a rate of 64 kbps maximum transmission in the uplink. The possible transport formats for the case of the interactive service are the detailed ones in the table 5.3.

The interactive traffic model considers the periods of activity generation (as it corresponds to a Web navigation service), where certain information is generated, and a certain reading time among them, simulating the interactivity of this class.

The specific parameters are described in table 5.3.

The simulation model includes a radio cell of 500meters and the intercellular interference is modeled like a proportional factor to the intracellular interference ($f = 0.6$).

CHAPTER 6. Simulations Results

6.1. Introduction

This chapter is centered in the study of the obtained results for the load condition (congestion control), with the Maximum Rate algorithm. In addition a possible improvement of this control will be seen, imposing certain conditions and it will be verified that these results are better than the previous.

We are interested on the cell breathing problem when a user is near the maximum distance and there is the possibility of being rejected or to loose the connection. With the new proposed algorithm we will see if it is possible to improve this problematic effect.

6.2. Reference Results when no bit rate reduction is applied

In this section, the reference results are presented for the case that the bit rate reduction algorithm is not applied. The next section will show the results with the new bit rate reduction algorithm that we proposed in section 4.3.

In the simulations with the power condition, the interactive users' admission based on the used load factor, also observing the number of droppings, the delay and the use of transport format.

Thus the simulations have been made with a load factor $\eta_{www}=0,9$.

Since it has been observed previously, simulations have been implemented with the Maximum Rate algorithm. With this algorithm the users usually transmit with TF4, i.e., to the maximum possible rate.

The simulations we have been done with the described parameters in table 5.5 and for 300, 500, 700 and 900 WWW users.

The obtained results are based on the users' number and on the used limitations.

The results that we can observe in the tables 6.2 and 6.3 are the probability of dropping, the delay and the use of transport format.

Table 6.1 Probability of dropping and delay with MR for an $\eta=0.9$.

Eta=0.9 Without new algorithm		
NumWWW	Prob droppingWWW	RetWWW(s)
300	0.01091327	0.11755061
500	0.01079075	0.11847179
700	0.04723046	0.11832744
900	0.52165599	0.13181647

Table 6.2 Used transport format with MR for an $\eta=0.9$.

Eta=0.9 Without new algorithm				
NumWWW	TrWWWtf1(%)	TrWWWtf2(%)	TrWWWtf3(%)	TrWWWtf4(%)
300	1.390536125	1.915769091	9.963693574	86.73000121
500	1.41870174	1.942586914	10.19765766	86.44105368
700	1.382466711	1.906271486	9.93969422	86.77156758
900	1.040894217	1.409629292	7.874398765	89.67507773

Observing the table 6.1, we can observe the increase of the dropping probability in function of the increase in the interactive users. For 900 WWW users we can note a 52% dropping probability. This is happening, because most of users, approximately an 86% are transmitting at the maximum rate. So, the cell load will be high.

Another important parameter that shows the utilization of the MR algorithm for all users is the delay. If most of users transmit at maximum rate, the delay will be low.

If most of users try to transmit at the maximum rate, a lot of them will loss their connection. And if we observe the results of table 6.2 we can see that the TF4 is used, with an 86% aprox.

Once we have observed these results, we had thought about an improvement of the load condition. With these results the dropping probability for 900 users is a high value, is necessary to reduce it, i.e., it is necessary to decrease the cell load. This improvement, as we said in chapter 4 must allow accept more users with the studied parameters.

In this section we have observed the elevated value of the dropping probability, and the use of the TF4 for the most of the users. The delay is not elevated, but the cell loses too much connections. So, with the studied case in chapter 4 we must obtain a better fit of the system than with these results. And in addition if it can be, do the minimum possible congestion in the system.

6.3. Proposed bit rate reduction algorithm results

The load control studied with the Maximum Rate has shown coherent results with the previously explained theory. It has shown as the users are transmitting at the maximum possible rate, the interactive users' delay is not very high. But the dropping probability has a high value, so we think some algorithm to get the dropping probability lower.

The improvement will be seen in the previous point if we compare them with the same obtained parameters with the new additional conditions.

So later on we compare the dropping probability, the delay and the transport format use. After there will be shown a cell coverage scene of the new algorithm, there we can see all the users that are affected with the additional conditions.

Table 6.3 Improvement in the dropping probability when the proposed algorithm is considered.

NumWWW	Dropping prob. Without	Dropping prob. With
300	0.01091327	0
500	0.01079075	0
700	0.04723046	0.03735815
900	0.52165599	0.09638613

At table 6.3 we can see the improvement of the dropping probability. For 300 and 500 users the dropping probability has reduced totally. For 700 users the dropping probability decreases a little if we compare with the results without the new algorithm, but for 900 users, the difference is higher, the dropping probability has decreased more than the previous case.

So we can observe if we reduce the TF until TF0 we can diminish at the possible maximum of dropping probability. With this table we demonstrate that the new thought algorithm does the wanted effect.

But, for this algorithm, we have some disadvantages. One of this is the users delay. As we reduce their transmission rate, their delay has to increase.

So for 700 or 900 users in a cell we obtain higher delay values for the proposed bit rate reduction algorithm

The next figure shows this:

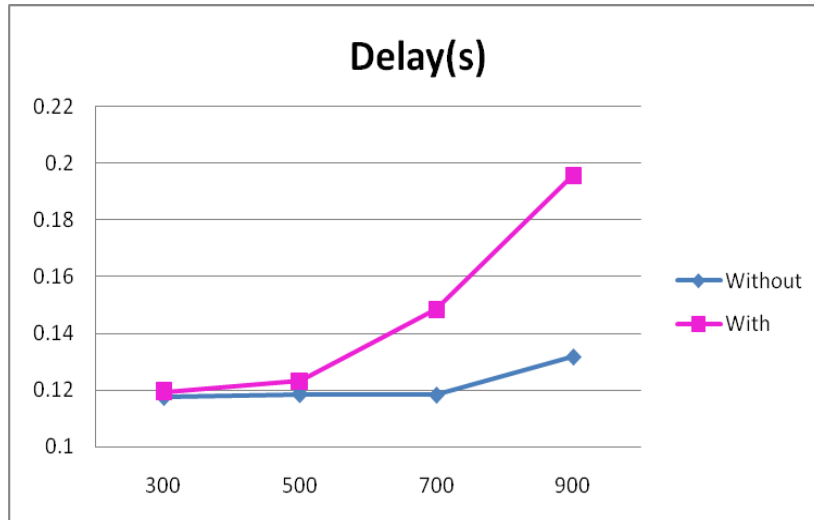

Figure 6.1 Average Delay.

When we see the obtained results done with the additional conditions we can observe the increase respect to obtained results without the new algorithm. With few users the difference is not considerable, but in function the users increase we can see that the difference between the results is higher. This difference is greater when there are 900 users.

These results are coherent with the theoretical explanation of the new algorithm. If we have more users in the cell, is probably that we will have more droppings, so we will need to reduce the users' TF.

Besides, we can verify that when the distance increases, the delay is higher. This happens with and without algorithm given that the mobile is far, there are more coverage problems, therefore there are more retransmissions and that affects to the delay.

So, with the new algorithm this delay increase in function in the distance will be a little higher that without the algorithm. We can see these conclusions in the next figure.

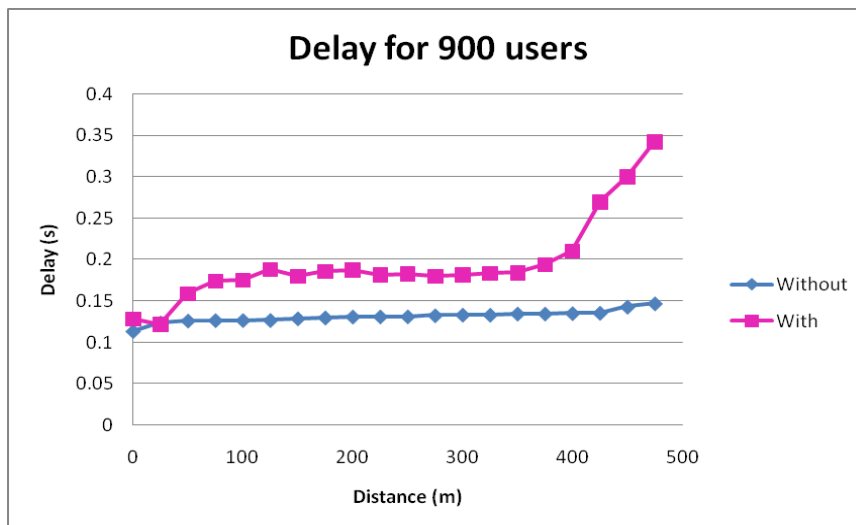

Figure 6.2 Delay based on the distance.

After we verify the delay increase, the others parameter to observed is the maximum transport format. We have to verify that this parameter has been increased when his value is TF1 or TF2, but when his value is TF4, the maximum transport format has been reduced.

As we say in chapter 4, when we explain the new algorithm, first most of users transmit at TF4, but when is necessary the users' transport format are reduced to TF2 and TF1 mainly.

So the next figure shows the transport format utilization in function of the distance.

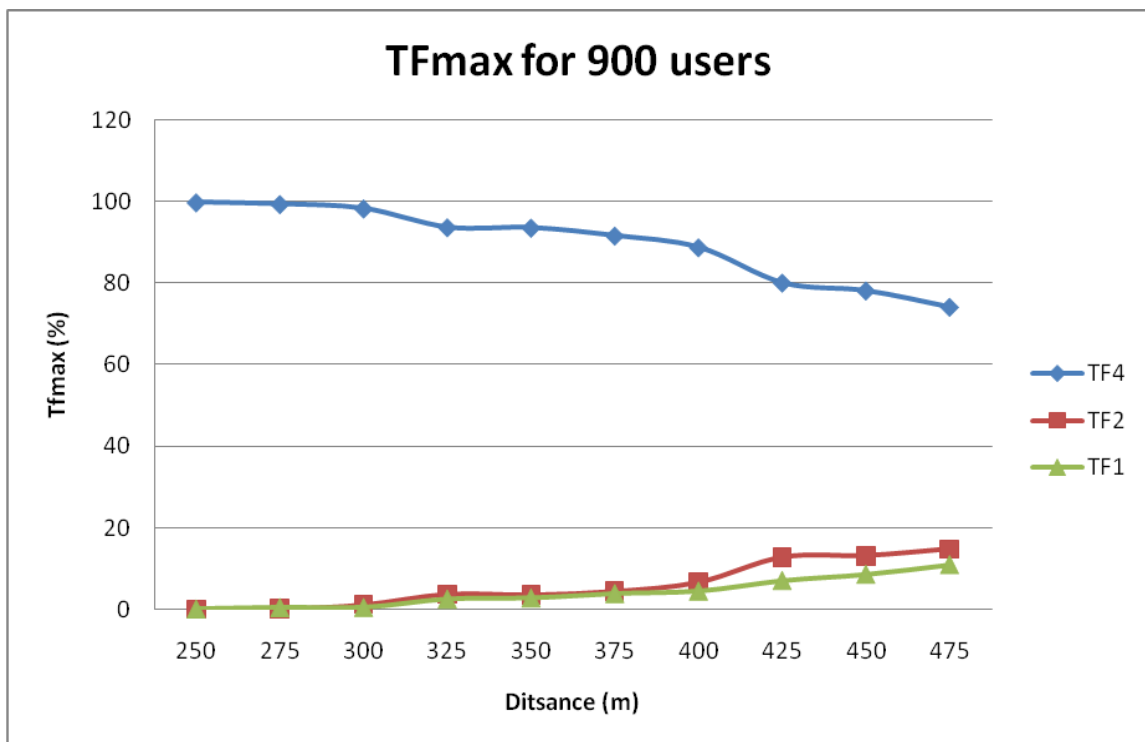

Figure 6.3 TFmax for 900 users.

With this graph we can observe that when the distance increases, the TF4 utilization decrease and the TF2 and TF1 utilization increase. In this way when there are 900 users in the system the TF4 decreases until a 75% utilization and the use of TF2 and TF1 increase until a 25%. These results prove the fine operation of the algorithm, and the relation with the theory study.

In chapter 4 we study that if we choose a different bit rate values, we can have a higher margin of maximum distance or the maximum transmitted power. And in figure 6.6 has been demonstrated that the algorithm reduces the bit rate to users that are more far.

Until here, we could compare the results of having the new algorithm or not. After that, we can demonstrate the operation of these additional conditions with the number of TF reconfigurations of the transport format.

For the well operation of this new algorithm is necessary that the number of TF reconfigurations of the transport format not differs too much, because it is important that all users try to transmit at maximum transmission rate, but always expiring the new algorithm.

Another way to prove that the algorithm goes well is the image of a cell with the users that have their transport format limited.

As we say previous results shows the good working of the new algorithm, we can observe that the most users that are limited, then can recuperate their transport format or increase until TF2 if the limitation has been of TF1.

The results can be seen with the next figure:

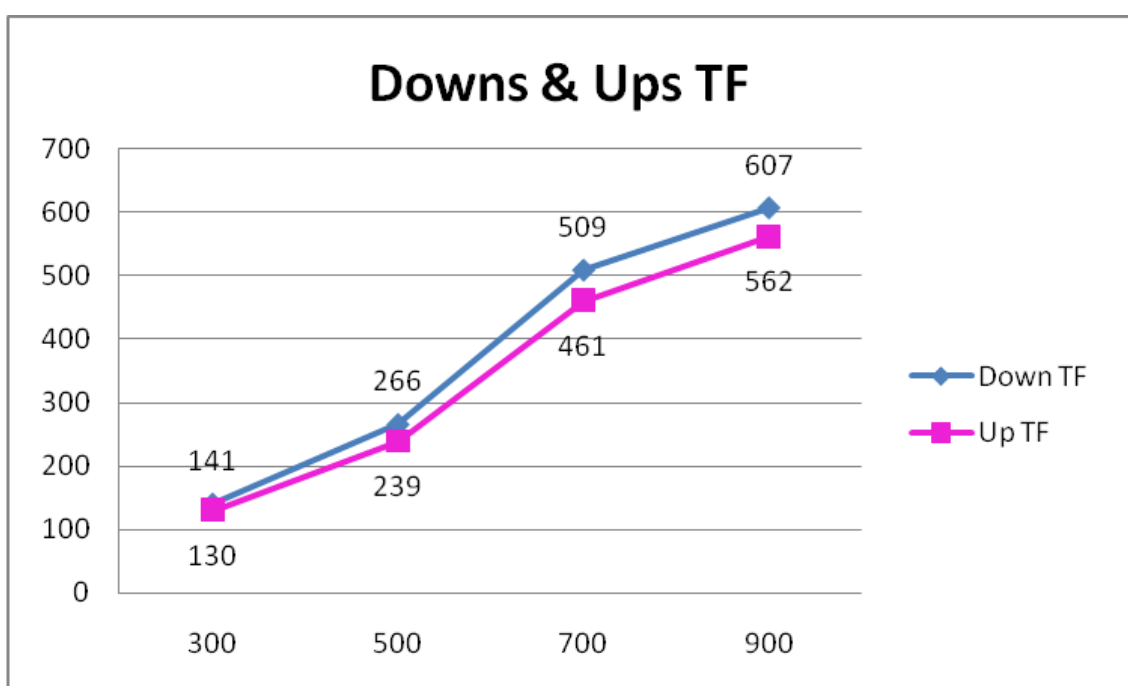

Figure 6.4 Number of TF reconfigurations of the transport format.

The TF reductions parameter shows the users that had their transport format limited to TF2. The next table shows the user limited with TF1, and with TF0.

We can see more TF reductions numbers of TF2 because is the first limitation applied. Then a TF1 limitation has lower TF reductions numbers than for TF2. Finally the TF0 limitation is the fewer applied.

With this numbers we can demonstrate that as more TF reductions are, the user's delay is higher. If we look at the results for 900users, we observed a total of 607 TF downs, but 192 down TF1 has been necessary. All these TF reductions have an involvement to the users' delay, as we see before.

Table 6.4 TF reductions

NumWWW	TF down numbers	TF1 down numbers	TF0 down numbers
300	141	40	11
500	266	88	26
700	509	166	46
900	607	192	39

Finally to have the certainty of the limited users are the ones near the border cell coverage, we have represented the cell and have marked all the users that have a down TF.

The next figures show the representation of the user marked for the algorithm because they would have problems with the connection.

First we show a coverage cell representation with 300 users and then another figure points out the situation of limited users when there are 700 users.

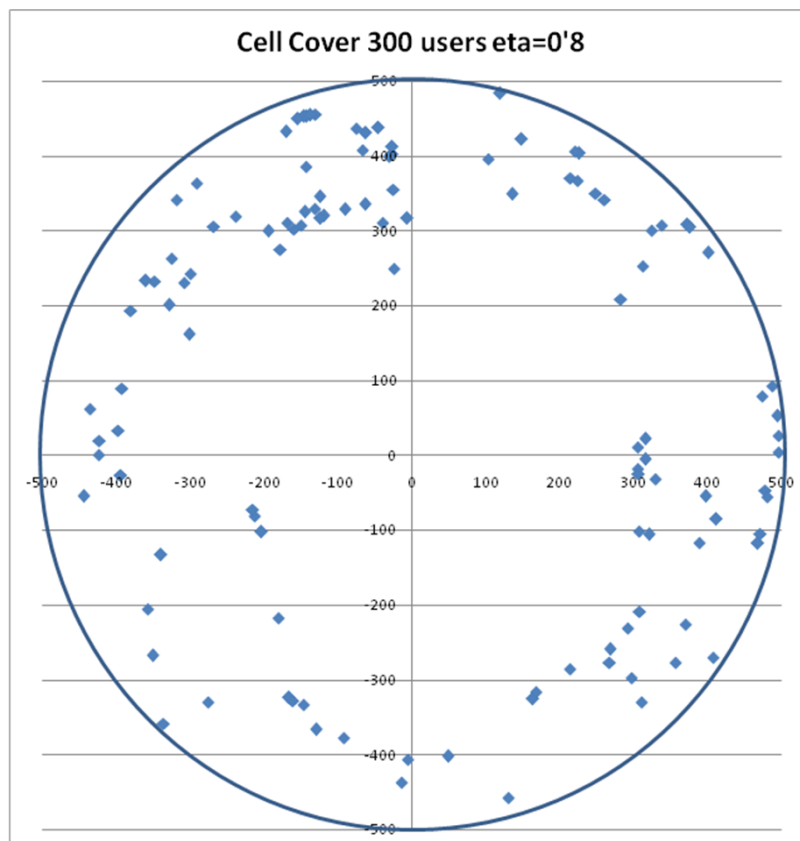

Figure 6.5 Limited users in cell coverage for 300 users.

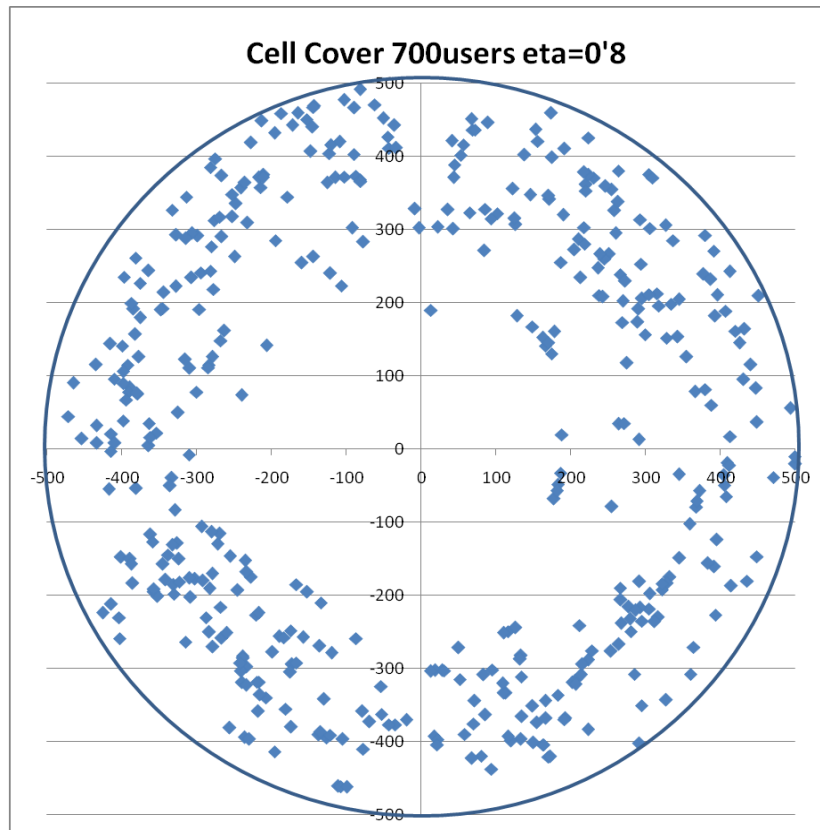

Figure 6.6 Limited users in cell coverage for 700 users.

In two figures are shown that the limited users are the ones that are near the border. In the case of 700 users, we can comment that some users that are not in the border are limited too, because when there are more users, there are more droppings and the users limited can be more near of the base station due to the cell-breathing effect.

With both figures we return to demonstrate the well implementation of the new algorithm implement.

CONCLUSIONS

Once the project has finished, we can see the established objectives and to evaluate them if they has realized all of them.

The established objectives at the project beginning have done satisfactorily. We did two studies, one of the Radio Resources Management, and other of the Cell Coverage.

First we studied the load condition and we can implement a new algorithm for this condition and we obtained coherent results according with the theory of the RRM.

The other study is the one of the cell coverage. This study demonstrated the relation between the load factor, the distance and the path loss. And this relation is shown at the obtained results with the proposed bit rate reduction algorithm.

The algorithm has implement with a new condition algorithm in the existent simulator in order to reduce the dropping probability and improves the cell breathing effect. This new strategy demonstrates the different results in cell coverage based on the transmission format selection.

The principle derived conclusions of the studies through simulation have been:

In the simulations with MR and without the new algorithm implemented we noticed that the load is high because the MR algorithm uses TF4, the maximum transport format. So the dropping probability is high too, perhaps too much if we want good conditions in the cell.

The conclusions of the new algorithm results are that if we vary the users' transport format in function of their transmitted power, we can obtain less dropping probability, and so more users transmitting in cell. With the proposed algorithm the dropping probability is reduced at expenses of a slight increase of the user delay.

In summary, we have as conclusions:

- A global delay higher with the code than without it. This is logical and we demonstrate with the new algorithm idea.
- A delay based on the distance slightly higher with the algorithm that without it. In the two cases the delay increases in function of the distance.
- Fewer droppings for most of users. For 300 and 500 users there are not dropping probability and for 900 users we obtain only a 9% of dropping probability with the algorithm meanwhile first we have a 52% dropping probability without the new algorithm.

- A similar TF reconfigurations number shown that the algorithm realizes the actions that we have program.
- A TF4 decrease like TFmax in function of the distance. This demonstrates the new algorithm does that we claim and the theory study part, when we comment that the use of different bit rate varies the cell diameter.
- Visual demonstration of the algorithm working with the cell coverage graphs and the involved users in the algorithm because they can have a dropping.

With the fulfilled objectives it has been opened a future line in this project, with an idea of improvement, waiting to obtain similar results, but with an algorithm fairer.

Once we observed the obtained results, we can assure that the algorithm works perfectly, but we can think to improve some of the disadvantages that the algorithm has.

At this point we want to contribute an idea to improve a concrete aspect. This aspect is that the new algorithm, of the future lines, be fairer than the algorithm implemented in this project.

On this project, we always reduce the transmission bit rate of users located usually far from the base station (figure 4.3). But it is evident that this is not fair.

So our proposal, for a new project continuing this, will be to apply the same algorithm but using a random function to choose a user to decrease his transport format. With this new variation it is not important the user's position and we are going to reduce the difference between the users' bit rate placed near and far of the base station.

BIBLIOGRAPHY

Books

- [1] Holma, H. and Muszynski, P., "Introduction to WCDMA", Cap. 3 en *WCDMA for UMTS*, Holma, H., Toskala, A., Eds., p.p.25-40, John Wiley & Sons, Ltd (2000).
- [2] Longoni, F. and Lämsä, A., "Radio Access Network Architecture", Cap. 5 en *WCDMA for UMTS*, Holma, H., Toskala, A., Eds., p.p.25-40, John Wiley & Sons, Ltd (2000).
- [3] Holma, H., Laakso, J. and Salonaho, O., "Radio Resource Management", Cap. 9 en *WCDMA for UMTS*, Holma, H., Toskala, A., Eds., p.p.25-40, John Wiley & Sons, Ltd (2000).
- [4] Hernando, J.M. y Lluch, C., *Comunicaciones Móviles de Tercera Generación Vol. 1*, Ed. Telefónica Móviles España, Madrid, 2000.

Documents

- [5] Sánchez, J., Pérez-Romero, J., Sallent, O., Agustí, A., Integración de tráfico conversacional e interactivo en la red de acceso radio de UMTS, Universitat Politècnica de Catalunya.
- [6] Sánchez, J., Pérez-Romero, J., Sallent, O., Agustí, A., Estrategias de Gestión de Recursos Radio, Universitat Politècnica de Catalunya.
- [7] García, M., "Tema 6. UMTS", Apuntes de clase de *Comunicaciones Móviles*, 2004-2005.

Links

- [8] UMTS Forum
<<http://www.umtsforum.net>>
- [9] Telefónica Investigación y Desarrollo
<<http://www.tid.es/>>
- [10] Projecte Arrows de la UPC
<http://www.arrows-ist.upc.es/>
- [11] Radio Communication Research Group UPC
<http://www.gcr.tsc.upc.es/>

ANEXO 1. BIT RATE REDUCTION ALGORITHM

```

if( usuari->u[cell][i].potTx > (PotMaxMS/Inc) )
{
    usuari->u[cell][i].problemaPot++;

    if(usuari->u[cell][i].problemaPot==100)
    {
        // hay que bajar el TFC al usuario i
        usuari->u[cell][i].rab.TFCmax[flag_link]=2;
        bajaTFC++;
        fprintf(fit_congestio,"%ld      %8lf  %8lf  %ld  \n",trama,usuari->u[cell][i].c.r[cell],usuari->u[cell][i].c.th[cell],taula->p[cell][petic].usuari);
    }

    if(usuari->u[cell][i].problemaPot==150)
    {
        usuari->u[cell][i].rab.TFCmax[flag_link]=1;
        bajaTFC1++;
    }

    if(usuari->u[cell][i].problemaPot==200)
    {
        usuari->u[cell][i].rab.TFCmax[flag_link]=0;
        bajaTFC0++;
    }

}
else
{
    usuari->u[cell][i].problemaPot=0;
}

if((usuari->u[cell][i].potTx < (PotMaxMS/Inc))&&(usuari->u[cell][i].rab.TFCmax[flag_link]!=4))
{
    usuari->u[cell][i].tramas_para_desactivacion++;
    usuari->u[cell][i].tramas_tiempo_limitado++; //olga_modif3

    if(usuari->u[cell][i].tramas_para_desactivacion==100)

```

```

{
    //hay que subir el TFC al usuario i
    usuari->u[cell][i].rab.TFCmax[flag_link]=4;
    subeTFC++;

    for (i=0;i<(num_WWW[cell]+num_RT[cell]+num_BE[cell]+num_Str[cell]);i++)
    {
        estadistica_tiempo_limitado+=usuari->u[cell][i].tramas_tiempo_limitado;
    }

    tiempo_medio_limitado=(double)estadistica_tiempo_limitado/(double)(num_W
WW[cell]);
}
if(usuari->u[cell][i].tramas_para_desactivacion==150)
{
    //hay que subir el TFC al usuario i
    usuari->u[cell][i].rab.TFCmax[flag_link]=2;
    subeTFC2++;

    for (i=0;i<(num_WWW[cell]+num_RT[cell]+num_BE[cell]+num_Str[cell]);i++)
    {
        estadistica_tiempo_limitado+=usuari->u[cell][i].tramas_tiempo_limitado;
    }

    tiempo_medio_limitado=(double)estadistica_tiempo_limitado/(double)(num_W
WW[cell]);
}
if(usuari->u[cell][i].tramas_para_desactivacion==200)
{
    //hay que subir el TFC al usuario i
    usuari->u[cell][i].rab.TFCmax[flag_link]=1;
    subeTFC1++;

    for (i=0;i<(num_WWW[cell]+num_RT[cell]+num_BE[cell]+num_Str[cell]);i++)
    {
        estadistica_tiempo_limitado+=usuari->u[cell][i].tramas_tiempo_limitado;
    }
}

```

```

        tiempo_medio_limitado=(double)estadistica_tiempo_limitado/(double)(num_W
        WW[cell]);
    }

}

else if(usuari->u[cell][i].rab.TFCmax[flag_link]!=4)
{
    usuari->u[cell][i].tramas_tiempo_limitado++; //Olga_modif3
}

if(usuari->u[cell][i].rab.trames_per_sota_target>trames_per_fer_dropping)
{
    usuari->u[cell][i].rab.trames_per_sota_target=0;
    if(taula->p[cell][petic].tipus_usuari==RT)
    {
        nombre_de_dropping_RT++;
        nombre_de_dropping_TOT++;
    }
    if(taula->p[cell][petic].tipus_usuari==WWW)//OLGA
    {
        nombre_de_dropping_WWW++;
        nombre_de_dropping_TOT++;
    }
    usuari->u[cell][i].rab.admission_flag=FALSE;
    usuari->u[cell][i].f.estat_font=EMPTY_BUFFER;
    usuari->u[cell][i].b.num_missatges=0;
    usuari->u[cell][i].dropped=TRUE;
}

prob_dropping_RT=((double)nombre_de_dropping_RT/(double)num_peticions_admeses_RT);
prob_dropping_WWW=((double)nombre_de_dropping_WWW/(double)num_peticions_admeses
_WWW);
prob_dropping_TOT=((double)nombre_de_dropping_TOT/(double)num_peticions_admeses);

if(usuari->u[cell][i].rab.TFCmax[flag_link]==4)
{
    est_tfc4[WWW][rang_dist]+=1.0;
}
if(usuari->u[cell][i].rab.TFCmax[flag_link]==2)
{

```

```

    est_tfc2[WWW][rang_dist]+=1.0;
}
if(usuari->u[cell][i].rab.TFCmax[flag_link]==1)
{
    est_tfc1[WWW][rang_dist]+=1.0;
}

for (i=0;i<MAX_DISTANCIA;i++)
{
    est_retTB_dist[j][i]=FRAME_TIME*est_retTB_dist[j][i]/est_numTB_rebuts_dist[j][i];
    est_numTB_perduts_dist[j][i]=100*TB_size[j][flag_link]*est_numTB_perduts_dist[j][i]/est_bits_oferts_dist[j][i];
    est_ret_dist[j][i]=FRAME_TIME*est_ret_dist[j][i]/est_miss_rebuts_dist[j][i];

    est_tfc4[j][i]=100*est_tfc4[j][i]/est_miss_rebuts_dist[j][i]; //Olga
    est_tfc2[j][i]=100*est_tfc2[j][i]/est_miss_rebuts_dist[j][i];
    est_tfc1[j][i]=100*est_tfc1[j][i]/est_miss_rebuts_dist[j][i];

    est_TO1_dist[j][i]=100*est_TO1_dist[j][i]/est_miss_rebuts_dist[j][i];
    est_TO2_dist[j][i]=100*est_TO2_dist[j][i]/est_miss_rebuts_dist[j][i];
}

for (k=0;k<MAX_TFCS;k++){
    est_trans_totals[j][k]=(est_trans_OK[j][k]+est_trans_KO[j][k])/(double)duracio;
    for(x=0;x<MAX_DISTANCIA;x++)
    {

        est_trans_totals4[j][k][x]=(est_trans_OK4[j][k][x]+est_trans_KO4[j][k][x])/(double)duracio;
//olga_ ok y ko tb con dist

        if (est_trans_totals4[j][k][x]>0.0)
        {

            est_trans_KO4[j][k][x]=100*est_trans_KO4[j][k][x]/(est_trans_totals4[j][k][x]*(double)duracio);

            est_trans_OK4[j][k][x]=100*est_trans_OK4[j][k][x]/(est_trans_totals4[j][k][x]*(double)duracio);

        }
        else
        {

            est_trans_KO4[j][k][x]=0.0; //olga

```

```
        est_trans_OK4[j][k][x]=0.0;
    }
}

if (est_trans_totals[j][k]>0.0){

est_trans_KO[j][k]=100*est_trans_KO[j][k]/(est_trans_totals[j][k]*(double)duracio);

est_trans_OK[j][k]=100*est_trans_OK[j][k]/(est_trans_totals[j][k]*(double)duracio);
    }else{
        est_trans_KO[j][k]=0.0;
        est_trans_OK[j][k]=0.0;
    }
}
```

ANEXO 2. GRAPHICS

2.1. Results Comparison

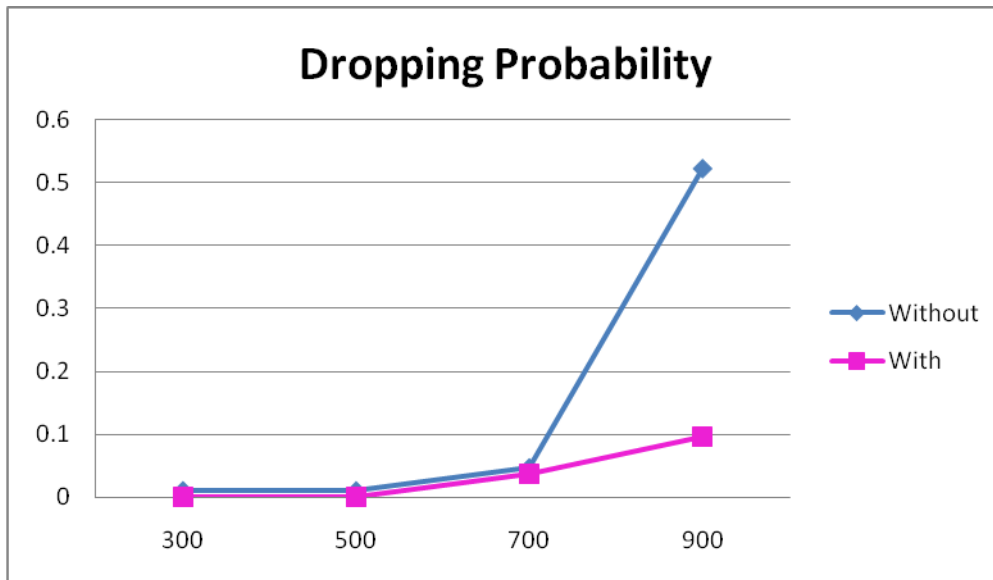

Figure 2.1 Drooping Probability

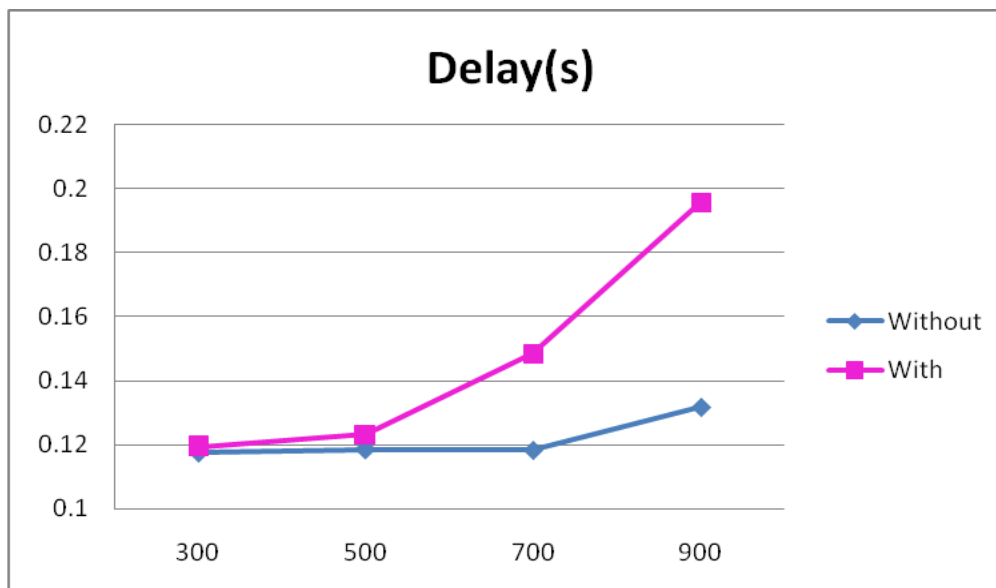

Figure 2.2 User's Delay

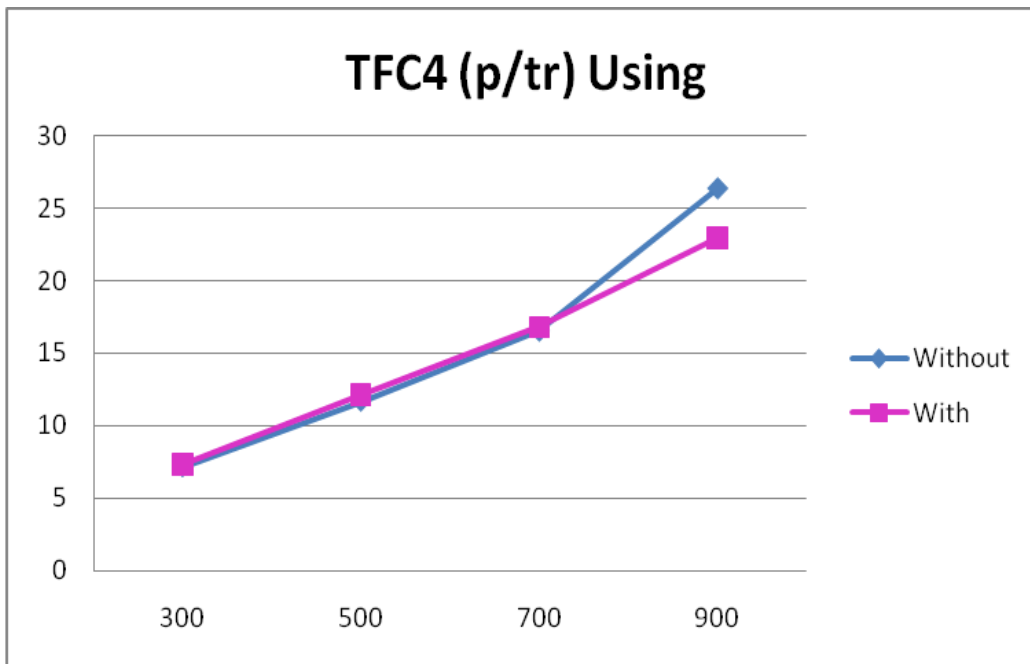

Figure 2.3 TFC4 utilization

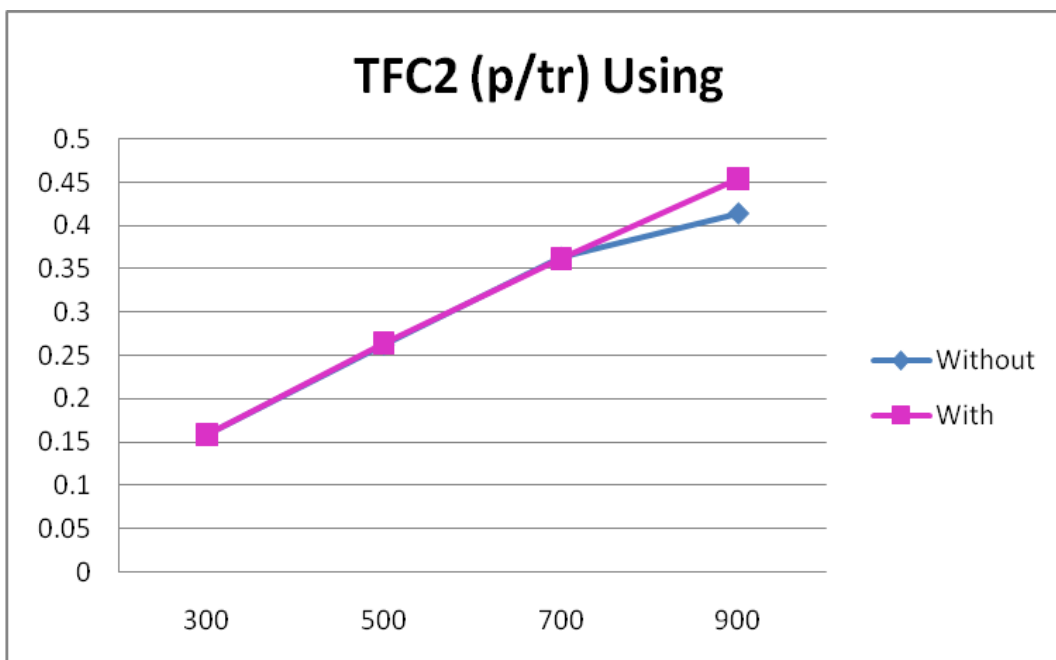

Figure 2.4 TFC2 utilization

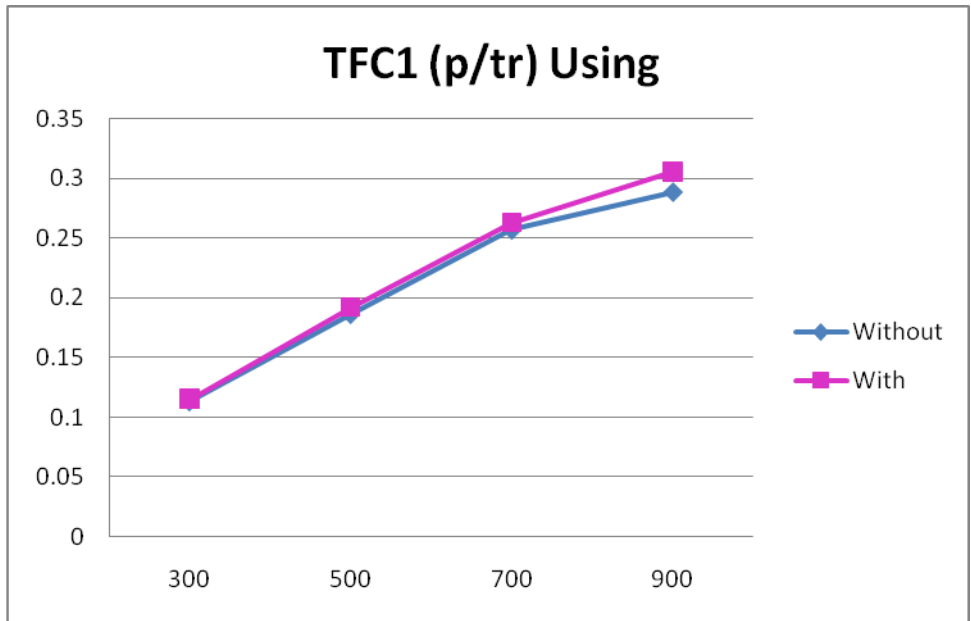

Figure 2.5 TFC1 utilization

2.2. Good working algorithm results

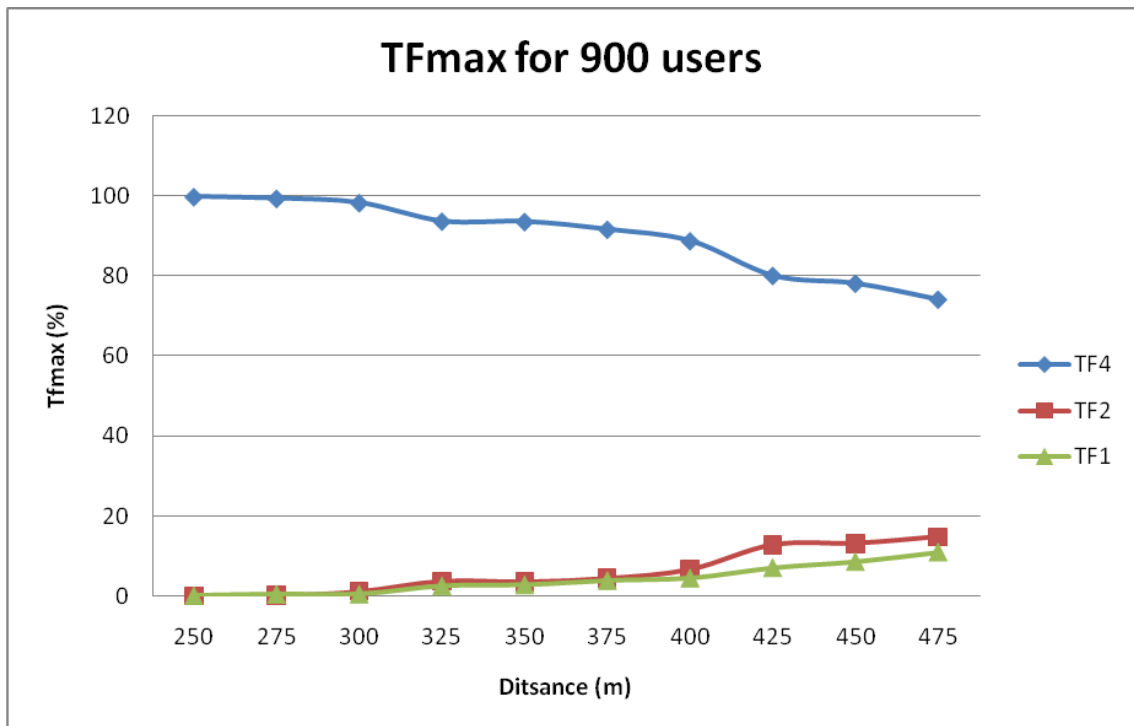

Figure 2.6 TFC utilization in function of the distance

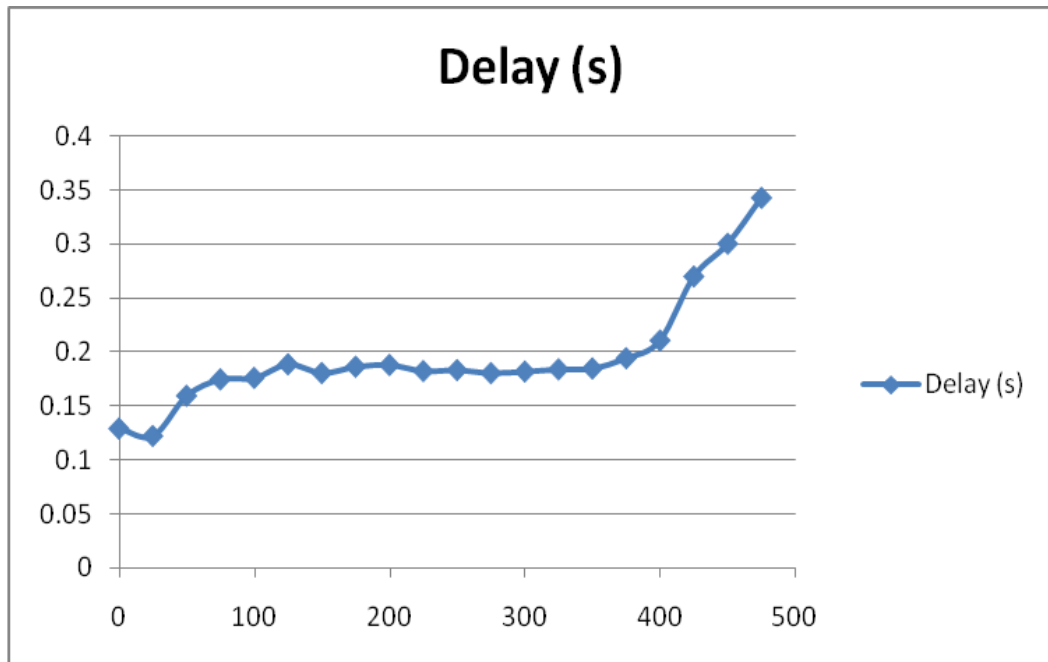

Figure 2.7 Delay in function of the distance

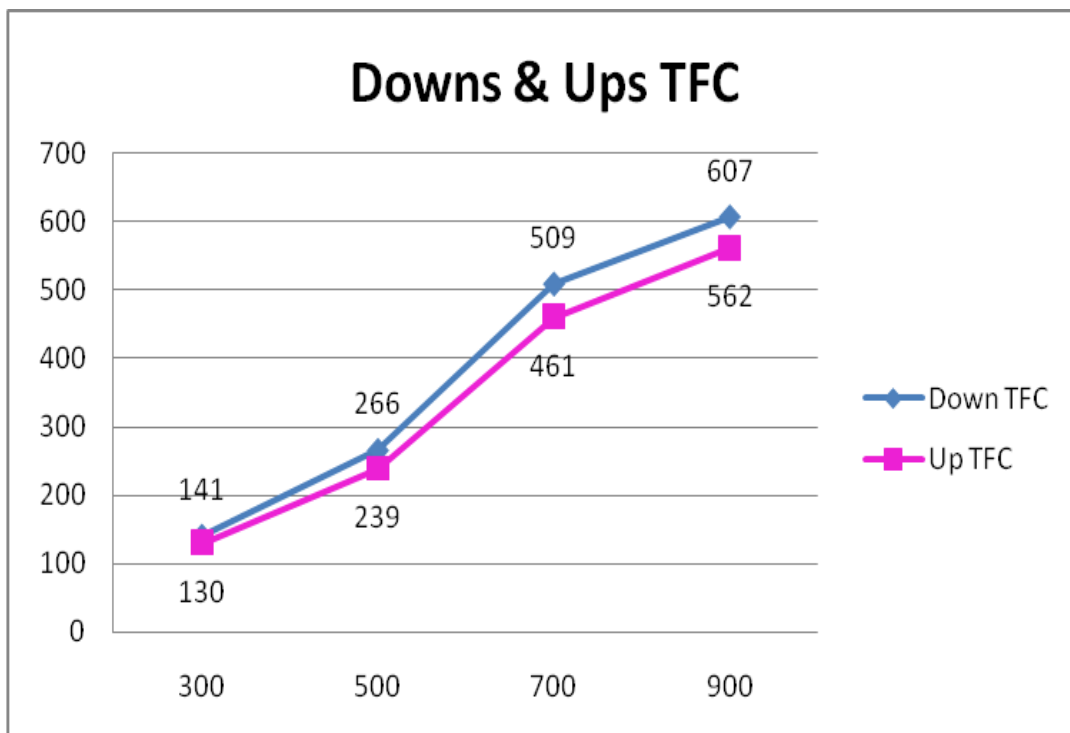

Figure 2.8 Number of the downs and ups of the TFC

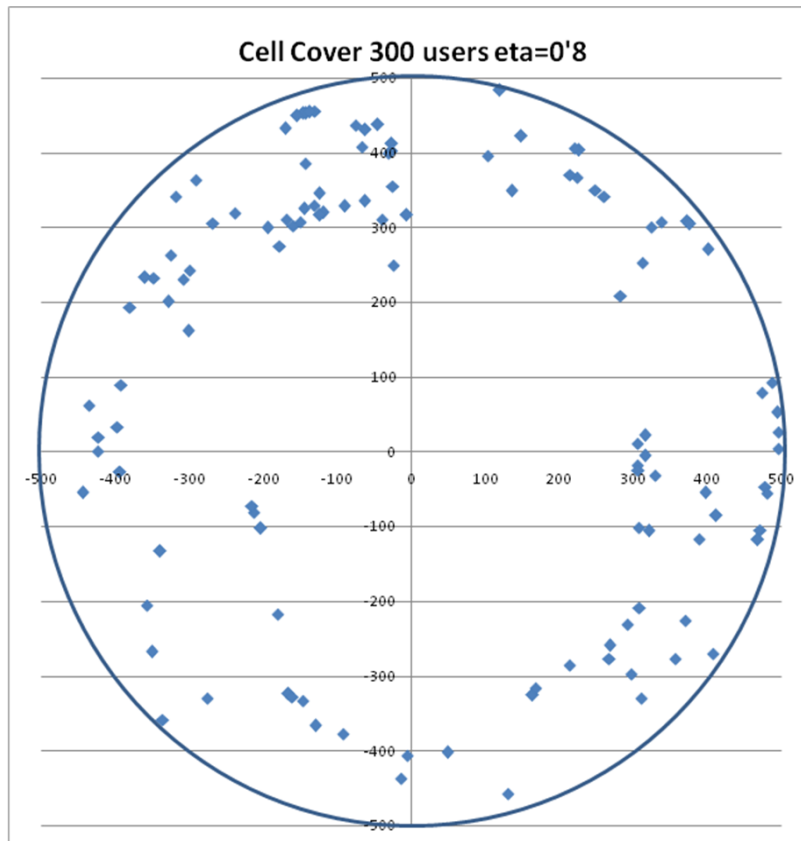

Figure 2.9 Downs and Ups TFC representation in a cell for 300 users

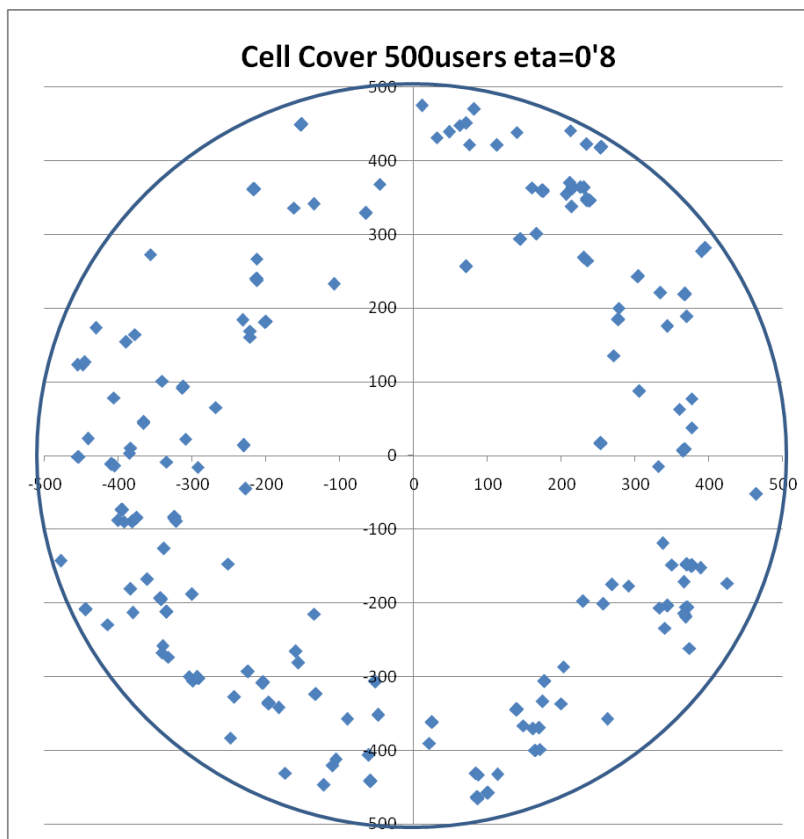

Figure 2.10 Downs and Ups TFC representation in a cell for 500 users

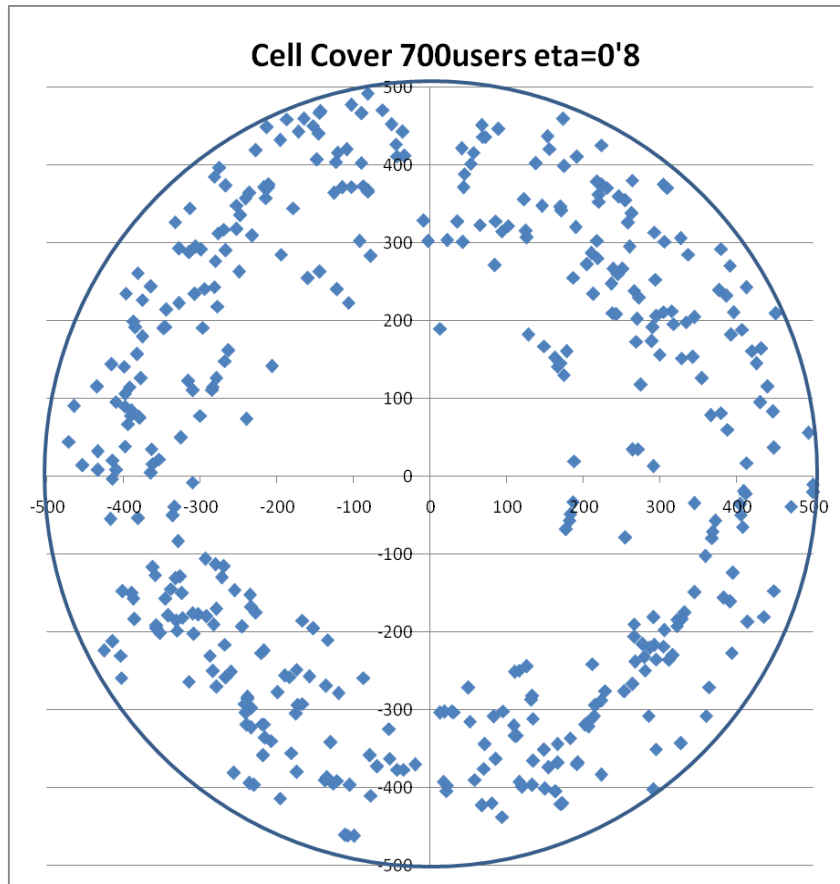

Figure 2.11 Downs and Ups TFC representation in a cell for 700 users

ANEXO 3. TABLES

3.1. Results Comparison

Table 3.1 Dropping probability results with and without new algorithm

NumWWW	Dropping prob. Without	Dropping prob. With
300	0.01091327	0
500	0.01079075	0
700	0.04723046	0.03735815
900	0.52165599	0.09638613

Table 3.2 Delay results with and without new algorithm

NumWWW	RetWWW(s) Without	RetWWW(s) With
300	0.11755061	0.11939045
500	0.11847179	0.12331768
700	0.11832744	0.14842695
900	0.13181647	0.19572562

Table 3.3 TFC4 utilization with and without new algorithm

NumWWW	TrWWWtfc4(p/tr) Without	TrWWWtfc4(p/tr) With
300	7.1665	7.2861
500	11.6985	12.1307
700	16.5325	16.8035
900	26.3625	22.9702

Table 3.4 TFC2 utilization with and without new algorithm

NumWWW	TrWWWtfc2(p/tr) Without	TrWWWtfc2(p/tr) With
300	0.1583	0.158
500	0.2629	0.2645
700	0.3632	0.3618
900	0.4144	0.454

Table 3.5 TFC1 utilization with and without new algorithm

NumWWW	TrWWWtfc1(p/tr) Without	TrWWWtfc1(p/tr) With
300	0.1136	0.1149
500	0.1864	0.192
700	0.2567	0.2634
900	0.2883	0.306

3.2. Good working algorithm results

Table 3.6 TFC utilization and delay in function of the distance

900 users with algorithm					
Dist(m)	RetWWW(s)	TFC4(%)	TFC2(%)	TFC1(%)	
0	0.12869983	100	0	0	
25	0.12181986	100	0	0	
50	0.15911542	100	0	0	
75	0.17439092	100	0	0	
100	0.17569084	100	0	0	
125	0.18840467	100	0	0	
150	0.18030406	99.98613413	0.00924391	0.00462196	
175	0.1860992	99.98261399	0.01738601	0	
200	0.18776512	99.98639607	0.01360393	0	
225	0.18206404	99.94516653	0.04400217	0.0108313	
250	0.18297838	99.84341293	0.04435514	0.11223194	
275	0.18021782	99.41799013	0.11247222	0.46953765	
300	0.18162955	98.33029174	1.17091513	0.49879313	
325	0.18367726	93.70083226	3.72517146	2.57399628	
350	0.1845161	93.60725375	3.55627924	2.83646701	
375	0.19398625	91.6540294	4.42284917	3.92312143	
400	0.21045591	88.76595644	6.6884192	4.54562437	
425	0.2699181	80.07666545	12.7829501	7.14038445	
450	0.30036295	78.14677236	13.1565478	8.69667984	
475	0.34291786	74.12437096	14.79726815	11.0783609	

Table 3.7 Number of downs and ups of TFC

NumWWW	Nombre baixades TFC	Nombre pujades TFC
300	141	130
500	266	239
700	509	461
900	607	562

Table 3.8 Users' position for 300 users

Angle:	Usuari:	Angle °:	X:	Y:
0.283249	287	16.2289723	-357.823452	-205.355724
0.248969	294	14.2648729	-39.844706	310.305444
1.09108	157	62.5142791	322.010766	-105.844649
-1.621973	126	-92.9322074	103.116721	395.21327
2.811697	238	161.098371	-180.497146	-217.076365
1.249941	211	71.6163439	-308.911766	230.136226
1.251541	287	71.7080172	-328.608436	200.845353
1.249244	267	71.5764088	-299.511904	242.313825
-0.497363	286	-28.4968008	-393.003586	88.901781
2.508508	286	143.726921	297.494726	-298.056108
-3.075617	211	-176.219873	389.362115	-116.481114
-2.98016	192	-170.75059	163.930975	-325.772907
-0.385257	226	-22.0736001	-397.68911	32.8645924
-1.391962	219	-79.7535478	-143.779708	385.411029
-2.555577	280	-146.423776	-129.539691	-366.532338
-2.391643	178	-137.03105	135.946856	348.670778
-1.770792	286	-101.458908	214.298112	-286.116805
0.330174	267	18.9175767	316.365638	21.552689
0.328695	273	18.8328362	315.981248	-5.28359596
-0.002379	279	-0.13630666	397.61243	-54.5353881
2.906023	299	166.502853	-424.096005	0.66056073
2.905263	299	166.459308	-423.515064	19.1144937
2.897858	299	166.035033	-380.815811	193.143367
0.145574	273	8.34077581	-159.680409	301.695197

0.145016	268	8.30880476	-149.987997	306.7129
0.143295	245	8.21019873	-118.938728	319.650339
0.141789	288	8.12391128	-90.858465	328.385421
0.140364	288	8.0422648	-63.8537707	335.119882
0.14358	280	8.22652802	-123.614609	316.315313
-0.284418	245	-16.295951	-348.518817	232.3384
-0.286026	245	-16.3880826	-325.454143	263.246452
-2.549903	246	-146.09868	-5.93955127	-406.186545
-2.547541	278	-145.963347	48.8206897	-402.476599
-0.738541	249	-42.3152823	-24.0053835	248.717768
-0.284174	226	-16.2819708	-360.653971	233.212274
-3.102118	291	-177.738269	-91.7880372	-377.88604
-1.961066	267	-112.360805	338.163889	306.629177
1.08262	263	62.0295568	267.685782	-276.888931
-0.567225	244	-32.4995985	167.685252	-316.566465
1.423949	272	81.5862679	329.579629	-31.4515075
2.358895	263	135.154728	-394.828116	-26.1932044
2.152692	210	123.340166	-336.552367	-359.282617
2.731193	246	156.485832	308.733761	-208.418244
1.114457	246	63.8536825	224.087812	366.345352
1.112654	296	63.7503783	260.7428	341.378318
1.113234	217	63.7836098	248.850269	349.283096
1.114845	217	63.8759133	215.152487	369.969622
2.189441	271	125.445729	472.293908	-104.611488
2.188941	292	125.417081	468.647527	-117.982113
2.191539	290	125.565935	478.826341	-46.9649806
-2.879188	294	-164.965321	-13.8733797	-437.409538
-3.024281	291	-173.278537	-302.129437	161.517794
0.104106	291	5.96483442	307.28853	-101.270065
2.622346	284	150.249358	370.450426	-225.64406
1.523591	262	87.295334	292.239321	-231.176174
1.521863	237	87.1963269	268.12394	-259.091456
-2.785009	239	-159.569262	-350.993454	-267.915979
3.099126	271	177.56684	-26.8812261	401.482972
-0.537244	235	-30.7818138	283.215804	208.286209
-2.928586	144	-167.795618	-130.774593	455.486601

-2.928094	106	-167.767428	-143.847331	452.520761
-2.928015	144	-167.762902	-146.128603	452.591247
-2.927691	217	-167.744338	-154.398034	449.489981
-2.928346	144	-167.781867	-137.250424	454.39022
-2.484783	296	-142.367579	-178.089124	274.877757
1.126852	217	64.5638637	-66.2760761	407.537609
1.125169	217	64.4674349	-26.7347551	412.087961
-0.645938	251	-37.0095212	373.18085	307.742875
0.358215	265	20.5242077	-45.6049532	437.539759
2.69324	284	154.311285	-339.718937	-133.034367
1.126546	294	64.5463312	-62.3310311	430.823506
2.413173	218	138.264628	306.553752	10.5960711
2.411511	238	138.169403	306.554582	-18.6228147
2.411181	173	138.150495	306.934975	-24.47814
0.560169	274	32.0953195	377.000206	304.487192
0.558666	191	32.009204	401.385286	270.659239
1.00847	222	57.7810748	148.63749	422.354759
1.481632	277	84.8912604	-394.474006	-26.9681973
2.440332	289	139.820724	-6.28677148	316.654363
0.147114	178	8.42901131	-194.103298	299.501625
0.144386	238	8.27270842	-144.754017	325.256094
0.138295	271	7.92371983	-24.8064038	355.130736
0.143709	248	8.23391918	-131.645846	329.658301
0.145757	275	8.35126093	-168.759514	310.919813
2.903588	296	166.363338	-436.20936	61.9487787
-1.934711	162	-110.850775	-291.61571	363.755876
-1.933371	299	-110.773999	-318.988159	340.670699
-1.955453	273	-112.039204	227.14945	403.561224
-1.955209	171	-112.025224	221.15695	406.09383
0.643762	271	36.8848456	310.980647	-329.474487
0.289392	97	16.5809402	-276.682388	-329.946459
-2.848337	138	-163.197689	474.451666	79.065807
2.424423	213	138.909206	312.673732	252.397003
3.017852	272	172.910183	-444.410011	-54.7533668
-2.930504	252	-167.905511	-74.7387222	436.191578
-0.400039	273	-22.9205463	-238.576016	319.498655

-2.598443	226	-148.879817	-124.527685	345.60845
-0.669477	294	-38.3582066	357.187449	-276.697184
2.660673	295	152.445334	-31.2183662	398.961932
2.671898	295	153.088479	-268.629056	305.518845
-2.873795	282	-164.656325	130.343816	-457.953924
2.376891	260	136.185823	-166.094329	-324.198119
2.377907	260	136.244035	-147.149183	-333.761211
2.377174	211	136.202037	-161.261917	-327.754957
3.071455	299	175.981408	496.975958	25.975632
3.070677	299	175.936832	496.971806	3.79880067
3.072387	299	176.034808	494.928679	52.4693868
3.073819	279	176.116856	488.409474	92.7497976
3.093725	299	177.257385	119.580574	483.2054
-3.11906	281	-178.708974	-213.260787	-80.7122788
-3.117251	252	-178.605326	-203.891314	-102.406782
-3.11971	281	-178.746216	-215.809637	-72.6120407
2.096629	281	120.127993	324.622379	300.887838
-3.036564	222	-173.982301	-170.664887	432.186655
-1.764787	247	-101.114847	408.341951	-269.804123
-1.75659	229	-100.645193	481.162698	-55.2027615
0.983393	217	56.3442685	412.662699	-85.5425785