

Hydropower plant models: water supply system, turbine and governor. Model validation: on site tests and grid fault simulation

J. Agüero ⁽¹⁾ B. Barbieri ⁽¹⁾, R. Bianchi ⁽¹⁾, J. Mastronardi ⁽²⁾ and R. Molina ⁽³⁾

⁽¹⁾ IITREE-LAT. Facultad Ingeniería. Universidad Nacional de La Plata
48 y 116 S/N, (2000) La Plata, Buenos Aires, Argentina. iitree@iitree-unlp.org.ar

⁽²⁾ Hidroeléctrica Futaleufú SA
Roca 790. (9200) Esquel, Chubut, Argentina. jmastro.hf@aluar.com.ar

⁽³⁾ CAMMESA
Ruta 35, Km. 3, (2121) Pérez, Santa Fe, Argentina. robertomolina@cammesa.com.ar

Abstract

Several tests were conducted at Futaleufú hydropower plant to improve plant related models because studies carried out in the past did not predict the power plant behaviour during grid faults. New models were used to reproduce Futaleufú power plant behaviour during a grid fault happened on December 14, 2006.

Keywords: Grid fault – Electromechanical oscillation - Hydraulic turbines – Power System Stabilizer – Water supply system

1. Introduction

Futaleufú power plant is composed of 4 hydro turbines Francis rated 118 MW. The water supply system has a static head between 155 m and 140 m and it is composed of:

- 1) A common conduit of approx. 8 m diameter and 1550 m length between reservoir and surge tank;
- 2) a common conduit of approx. 7.7 m diameter and 328 m length between surge tank and the point (trifurcation) where penstocks fan out to units 1 and 4;
- 3) a common conduit for units 2 and 3 of approx. 5.3 m diameter and 20 m length between trifurcation and the point (bifurcation) where penstocks fan out to units 2 and 3;
- 4) Penstocks for each unit of 3.7 m diameter and 10 to 60 m length (depending on unit);
- 5) Individual spiral chamber and turbine discharge conduits.

Futaleufú power plant is connected to the grid by 2x330 kV lines of 550 Km length between Futaleufú and Puerto Madryn substations.

Futaleufú substation feeds a local load (approx. 6 MW). Puerto Madryn substation is connected to the SADI (the biggest Argentinean grid) with one 330/500 kV autotransformer rated 400 MVA, and it is connected to the SIP (a small grid located in the south of Argentina) with two 330/132 kV autotransformers rated 60 MVA each.

Two autotransformers 330/33 kV rated 300 MVA each at Puerto Madryn substation feed a factory for electrolytic aluminium production (Aluar) with 450 MW of load and 280 MW of gas turbine generation.

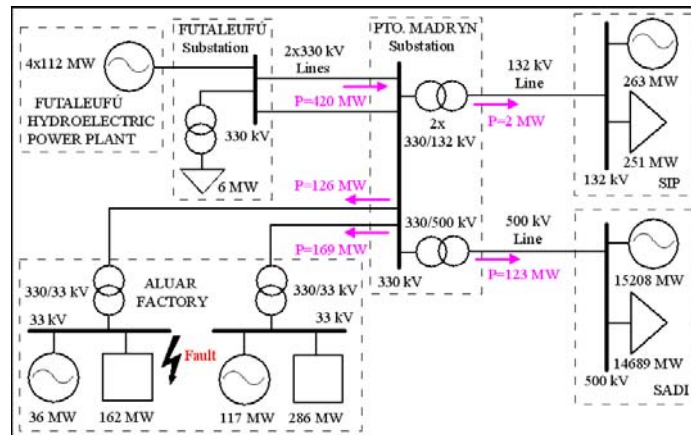

Fig. 1 – Pre-fault power flow (9:08 am, December 14, 2006).

Fig. 1 shows Futaleufú power plant, Futaleufú and Puerto Madryn substations, Aluar factory and the two Argentinean power systems involved, SADI and SIP.

To damp electromechanical oscillations each unit of Futaleufú power plant has a power system stabilizer (PSS), type PSS2A, using electrical power as input, with automatic static gain reduction in the power band of 40 to 85 MW due to surging in the hydraulic system, Ref. [8].

Also, Generation Automatic Disconnection (GAD) is used at Futaleufú power plant as a grid stabilizer resource to avoid low or negative damping of electromechanical oscillation when faults take place at 330 kV lines or at aluminium factory.

A new electromechanical oscillation mode appears with the interconnection SIP - SADI (February, 2006).

In this electromechanical oscillation mode machines from Futaleufú and Aluar oscillate against machines from SADI and SIP.

Carried out studies predict and operational experiences confirm that 330 kV system presents a correct damping for several configuration of Futaleufú power plant and 330 kV lines.

Two typical configurations are: a) 2x330 kV lines with 4 units up to 110 MW each; b) 1x330 kV line with 3 units up to 90 MW each.

On March 14, 2007, one 330 kV line was disconnected for maintenance. Futaleufú was operating with 3 units at 90 MW each.

Line disconnection caused a transitory fall of 18 MW in the electrical power of each Futaleufú unit due to the increasing of the longitudinal impedance of the 330 kV transmission system.

Then, the electrical power of each unit was inside a 40 to 85 MW band (hydraulic surging band) and PSS automatically reduced its static gain to zero.

In that condition, the electromechanical oscillation increased until after 40 seconds the second line of 330 kV became disconnected by the operation of the impedance protection.

The disconnection of the line for the same operative conditions of Futaleufú was done frequently and with well-damped electromechanical oscillation when SIP was not interconnected to SADI.

Carried out simulations established that the disconnection of the first 330 kV line causes an stable electromechanical oscillation if the PSS of Futaleufú are readjusted, Ref. [7].

The PSS readjustment consists of increasing from 0 to 0.3 pu the static gain reduction in the power band of hydraulic surging (40 to 85 MW).

The line was disconnected again with the PSS readjusted and the electromechanical oscillation was stable.

2. Models and Tests

Fig. 2 displays a complete model of Futaleufú water supply system.

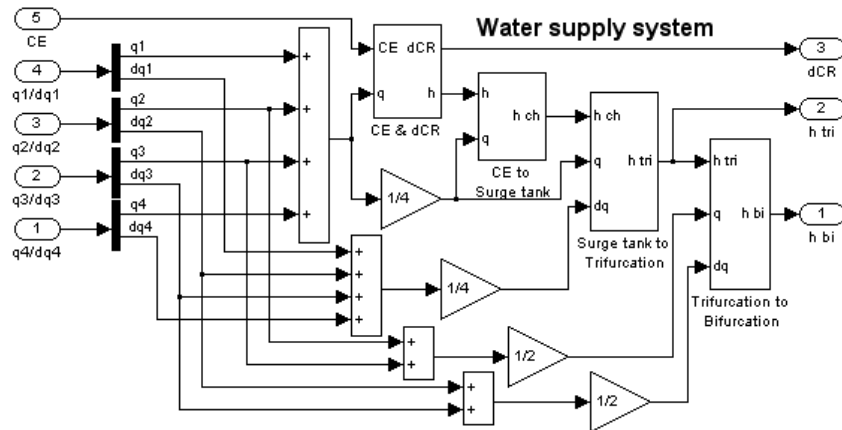

Fig. 2 – Futaleufú. Model of water supply system

Water supply model takes the reservoir level (CE) and flows (q_1 to q_4) and its derivatives (dq_1 to dq_4) from turbine models to generate bi/trifurcation heads (h_{tri}/h_{bi} , turbine input pressures) and the delta of restitution level (dCR, tailrace or output pressure) for the turbine models.

Second order models with non-elastic water column were used for turbines, Refs. [1-6]. Fig. 3 shows the turbine model. Turbines are Francis type and the turbine model takes into account the variation laws between gate position and flow (m , equivalent aperture) and between efficiency (η , ratio between mechanical and hydraulic powers) and flow. Firstly cited law also depends on the turbine applied pressures (input or admission minus output or tailrace).

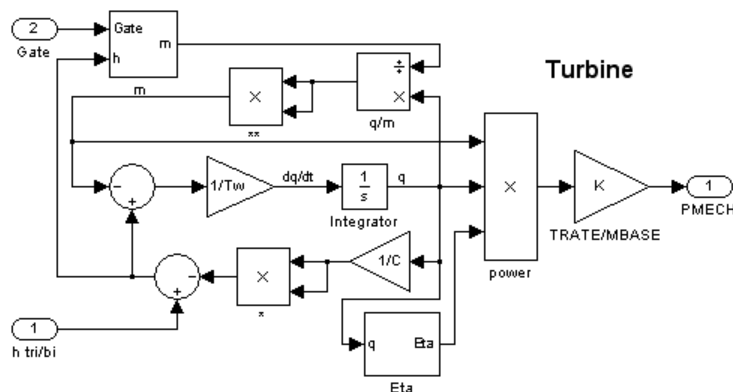

Fig. 3 – Futaleufú. Turbine model

The models for Excitation Control System, Excitation Limiters, PSS and Turbine Governor were also developed.

All models developed were verified by tests.

3. Grid fault simulation

Developed models were used to reproduce the Futaleufú power plant behaviour during a grid fault happened on December 14, 2006.

Fig. 1 displays an scheme of power flow at pre-fault time (9:08 am, December 14, 2006) showing Futaleufú power plant, Futaleufú and Puerto Madryn substations, Aluar factory, SADI and SIP.

Futaleufú power plant was operating with 4 units at 112 MW each and with 2x330 kV lines.

Fault was a three-phases short-circuit to ground in 33 kV side of one 330/33 kV feeding transformer in Aluar factory.

Aperture of 33 kV breaker rejected 126 MW of load.

To control voltage at Puerto Madryn the following automatic actions were taken:

- disconnection of 3x20 MVAR capacitor banks in aluminium plant,
- connection at 330 kV lines of first and second shunt reactors of 50 MVAR each,
- trip of one 330 kV line.

To control the grid stability the following automatic actions were taken:

- GAD of first Futaleufú unit (originated by load disconnection),
- GAD of second Futaleufú unit (originated by the 330 kV line trip).

At this time (in service: only one 330 kV line and two Futaleufú units) Futaleufú units begin to oscillate with negative damping up to the actuation of a large oscillation automatism which tripped the third Futaleufú unit.

Finally, the single Futaleufú unit in service was tripped by an overload protection because this unit increased its power from 112 MW to 135 MW.

Fig. 4 displays record of plant active power during the fault (sampling time 0,25 s) meanwhile Fig. 5 displays the same power obtained from fault simulation.

Simulation with developed models confirmed that system instability was caused by the turbines power increase.

This power increase was caused by the admission pressure raising generated by negative flow derivatives at tripped turbines.

Mechanical and electrical powers of latest tripped unit were increased from 112 MW up to 135 MW (0.19 pu, turbine rated base).

Governor did not react because it has “transient droop” feature (low gain for fast frequency deviation) and also because the maximum frequency error (-0.002 pu) was small.

Also, in the fault simulation it is observed that the outputs of PSS of Futaleufú reached their limits (± 0.0263 pu).

Output limits of these PSS are lower than the output limits (± 0.05 to ± 0.1 pu) of PSS of other power plants.

Fig. 6 shows the Futaleufú active power obtained in a fault simulation done readjusting the output limits of PSS of Futaleufú to $\pm 0,05$ pu.

It can be seen that the readjustment of these output limits made dynamically stable the electromechanical oscillation.

Fig.7 shows a PSS output of Futaleufú without and with output limits readjusted.

It can be seen that even with the output limits readjusted to 0.05 pu, the output of PSS is slightly limited.

4. Conclusion

Models tested in field of Futaleufú hydraulic power plant will be used to conduct system studies for re-defining all automatisms to obtain a post-fault power system that will be dynamically stable.

Also, Futaleufú power plant models will be used to conduct detailed studies of PSS and Governor tuning taken into account all possible operating conditions (quantity of unit in service, quantity of 330 kV lines in service, water reservoir level, SIP isolated or interconnected to SADI, etc.).

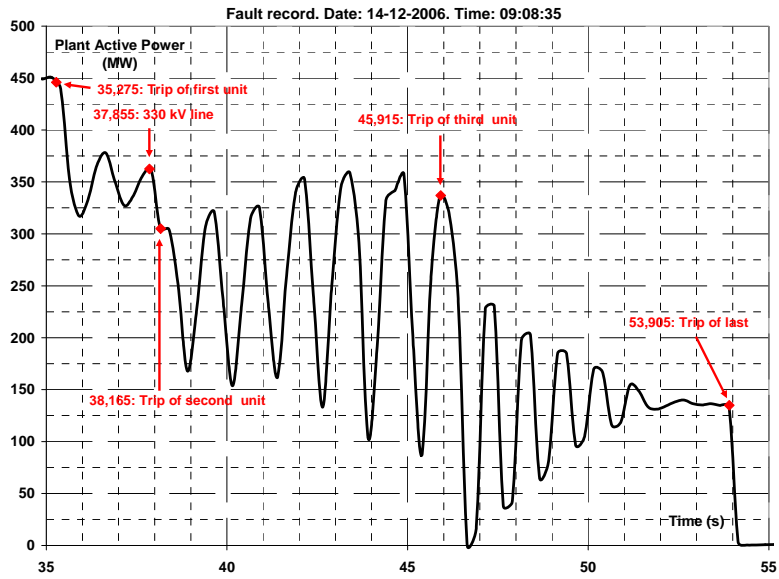

Fig. 4 – Fault record

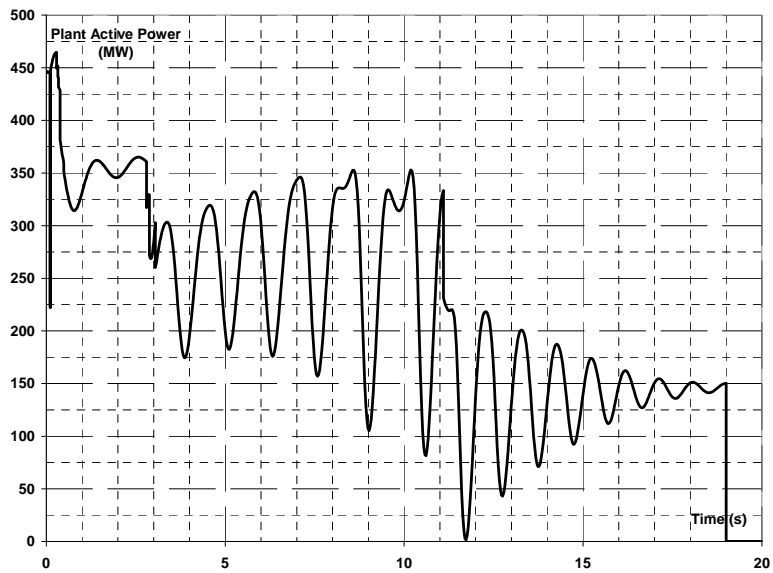

Fig. 5 – Fault simulation

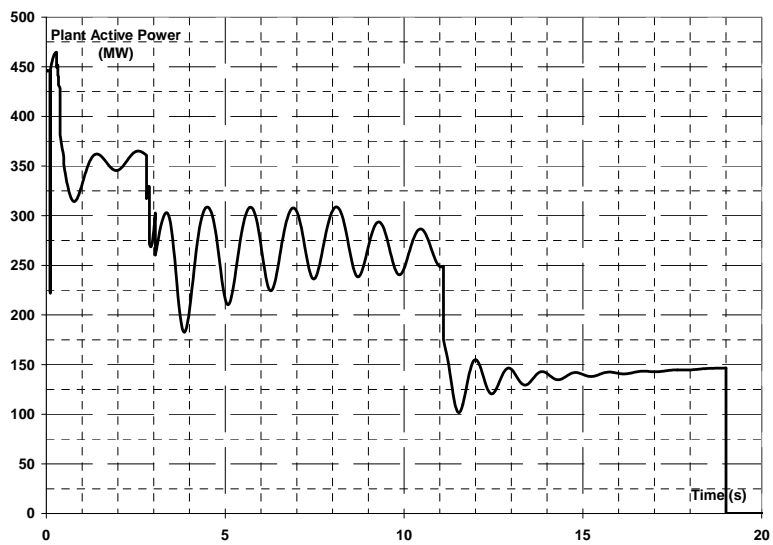

Fig. 6 – Fault simulation. PSS with output limits readjusted

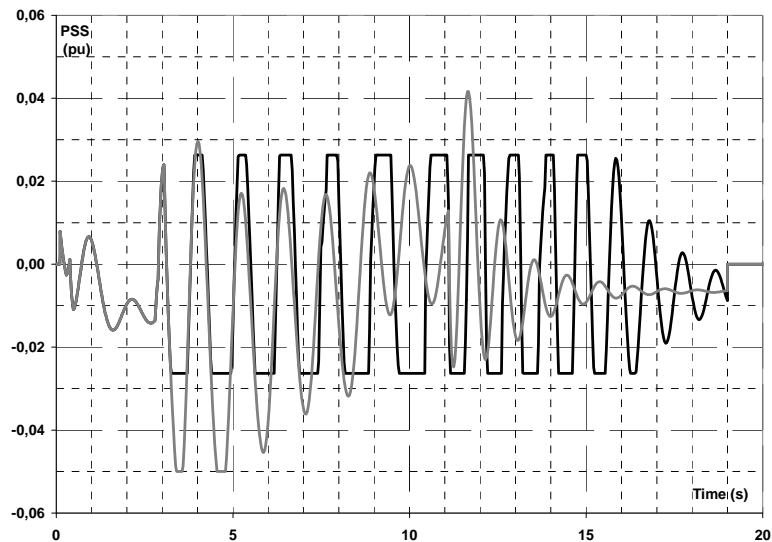

Fig. 7 –PSS output without (black) and with (grey) output limits readjusted

Acknowledgement

The authors would like to thank the personnel of Hidroeléctrica Futaleufú power plant for their invaluable collaboration during tests carried out at power plant.

References

- [1] Working Group on Prime Mover and Energy Supply. Models for system Dynamic Performance Studies, "Hydraulic Turbine and Turbine Control Models for Dynamic Studies", IEEE Transaction on Power System, Vol. 7, No. 1, February 1992, pp. 167-179.
- [2] C. Vournas, "Second Order Hydraulic Turbine Models for Multimachine Stability Studies", IEEE Transaction on Energy Conversion, Vol. 5, No. 2, June 1990, pp. 239-244.
- [3] E. De Jaeger, N. Janssens, B. Malfliet and F. Van de Meulebroeke, "Hydro Turbine Model for System Dynamic Studies", IEEE Transaction on Power System, Vol. 9, No. 4, November 1994, pp. 1709-1715.
- [4] D. Trudnowski and J. Agee, "Identifying a Hydraulic-Turbine Model from Measured Field Data", IEEE Transaction on Energy Conversion, Vol. 10, No. 4, December 1995, pp. 768-773.
- [5] O. Souza Jr., N. Barbieri and A. Santos, "Study of Hydraulic transients in Hydropower plants through Simulation of Nonlinear Model of Penstock and Hydraulic Turbine Model", IEEE Transaction on Power System, Vol. 14, No. 4, November 1999, pp. 1269-1272.
- [6] L. Hannett, J. Feltes, B. Fardanesh and W. Crean, "Modeling and Control Tuning of a Hydro Station with Units Sharing a Common Penstock Section", IEEE Transaction on Power System, Vol. 14, No. 4, November 1999, pp. 1407-1414.
- [7] R. Molina, J. Mastronardi, G. Lo Giudice, P. Belkenoff, M. Beroqui y J. Agüero, "Oscilación en la Central Hidroeléctrica Futaleufú. Diagnóstico y solución del problema", XII ERIAC, Décimo Segundo Encuentro Regional Ibero Americano de CIGRÉ, 20 al 24 de mayo de 2007, Foz de Iguazú, Paraná, Brasil, Publicación C1-05.
- [8] J. Agüero and M. Beroqui, "Electromechanical Oscillation Damping in one Hydraulic Central", 1999 Summer Meeting. Power Engineering Society. IEEE. Edmonton, Alberta, Canada, July 1999, Conference Proceedings SM 099, Vol. N° 2, pp. 1330-1335.
- [9] J. Agüero and M. Beroqui, "PSS Tuning in Generators located in a Manufacture Plant of Aluminum", 2000 IEEE Power Engineering Society (PES) Summer Meeting, Seattle, United States, July 2000, Conference Proceedings SM00, Vol. N° 3, pp. 1901-1905.