Performance control of semiconductor optical amplifier and fiber raman amplifier in communication system

by Okfalisa Okafalisa

Submission date: 30-Mar-2020 01:02PM (UTC+0700)

Submission ID: 1285100083

File name: amplifier_and_fiber_raman_amplifier_in_communication_system.pdf (3.58M)

Word count: 2605

Character count: 13663

Performance Control of Semiconductor Optical Amplifier and Fiber Raman Amplifier in Communication System

Roby Ikhsan[§], Ronadli Syahputra[§], Saktioto[§], Okfalisa[¶]

[§] Department of Physics, Mathematics and Natural Sciences, Universitas Riau
Kampus Bina Widya, Simpang Baru, Pekanbaru, Indonesia

[¶] Department of Science and Technology, Universitas Islam Negeri Suska, Pekanbaru, Indonesia
Corresponding author: saktioto@ieee.org

Abstract—Optical fiber communication greatly develops considering the limitations of communication systems corresponding to the demand of information needs. Optical fiber is one of waveguides that is able to transmit information with large capacity, high speed and low attenuation. Due to the very long distance, then the signal transmission needs to be maintained from the disturbance of geometry, materials and signal sources. To maintain the signal, optical amplifier is required although several amplifiers still have problems. This paper investigates the performance of Semiconductor Optical Amplifier (SOA) and Fiber Raman Amplifier (FRA). Using the simulation application, both amplifiers are designed and compared by inline amplifiers. The results showed that the transmission distance of FRA is more stable than SOA. However, this FRA system has higher power consumption when compared to the SOA system.

Keywords—fiber optic, SOA, FRA, optical amplifier

I. INTRODUCTION

Optical transmission media greatly affect the performance of a communication system. Fiber optic is one of transmission media which is capable of transmitting information with a large capacity, high speed and has low attenuation. Although optical fiber provides many advantages but there are also disadvantages that can disrupt the performance of the fiber optics, the effects that can limit the delivery and speed of data transmission. This effect is divided into linear effects and non-linear effects. Linear effects include attenuation and dispersion; a distortion in the beam of light passing through the optical fiber core caused by different modes, wavelengths and velocities. While non-linear effects arise due to Kerr effect in the form of Self Phase Modulation (SPM), Cross Phase Modulation (XPM) and Four Wave Mixing (FWM) and the result of Inelastic Scattering including Stimulated Raman Scattering (SRS) and Stimulated Brillouin Scattering (SBS) [1]. These linear and nonlinear effects can damage information signals such as widespread light pulses, reduced

bandwidth shortened, transmission distance and limited bit rate. All this is a communication disorder.

The suitable amplifier is one way to deal with the effects of linear and non-linear disturbances as well as maximize the working of optical transmission media. Generally the optical amplifier consists of Semiconductor Optical Amplifier (SOA), Fiber Raman Amplifier (FRA) and Erbium-Doped Fiber Amplifier (EDFA). SOA is designed in the form of Quantum Dot SOA network as linear network and Bulk SOA as nonlinear network [2]. Then, it is known that SOA has a high non-linear nature, low power consumption, fast operating speed, and can easily be used in photonic systems [3-6]. In SOA type amplifier, the gain can be calculated using the following equation:

$$g_m = A_g (N - N_0) \quad (1)$$

where

g_m : material amplifier

A_g : coefficient of derivative gain

N : carrier density

N_0 : carrier density at the point of transparency

$$g_t = \Gamma g_m - \alpha \quad (2)$$

where

g_t : coefficient of amplifier

Γ : optical confinement factor

α : effective loss coefficient

$$G = \exp(g_t z) \quad (3)$$

where G is magnitude of gain (dB) and z is length of optical fiber (m).

Then Bromage introduced the Raman amplifier used in fiber optic communication systems [7]. The gain on this amplifier can be calculated using the equation as follows,

$$G = 10 \log(\exp(gPL)) \quad (4)$$

$$g = 2\gamma p \text{Im}(\chi_{1111}(\omega_p - \omega_s)) \quad (5)$$

$$\gamma = \frac{2\pi n_2}{\lambda A_{eff}} \quad (6)$$

where

- P : power pump (Watt)
- L : length of optical fiber (m)
- g : Raman gain coefficient
- γ : non-linear phase change (rad)
- ρ : non-linear polarization fraction
- $\chi_{1111}(\omega_p - \omega_s)$: Raman's susceptibility
- n_2 : non-linear refractive index ($m^2 \cdot W^{-1}$)
- A_{eff} : effective surface (m^2)
- λ : wavelength signal (m)

Both amplifiers show that the type of SOA more considered the carrier density and the material factor, whereas FRA more considered the frequency characteristics and wave non-linear conditions. However, both amplifiers are very dependent on the media passed by the signal. In order to investigate the performance SOA and FRA, bit error rate (BER) and Q-factor are two parameters used to measure their characteristics.

BER and Q-factor is one of the most important factors that limiting the transmission distance in optical communication system. In order to transmit signals over long distances, it is necessary to have a low BER and high Q-factor within the fiber. The optical amplifier in the fiber represents the optical signals to directly amplified optically without any conversion. The BER is an indication of how often data has to be retransmitted because of an error. Too high a BER may indicate that a slower data rate would actually improve overall transmission time for a given amount of transmitted data since the BER might be reduced, lowering the number of packets that had to be present. Bit error rate (BER) as the number of detected bits that are incorrect before error correction, divided by the total number of transmitted bits (including redundant error codes). Normally, the transmission BER is larger than the information BER. The information BER is affected by the strength of the forward error correction code. There are kinds of BER occurring in a communication system. It may be affected by transmission channel noise, interference, distortion, bit synchronization problems, attenuation, wireless multipath fading, etc. However, in both amplifiers, we consider as the simple channel model and data source model.

Another factor is Q-factor, a parameter that describes the resonance behavior of an underdamped harmonic oscillator (resonator). Sinusoidally driven resonators having higher Q factors resonate with greater amplitudes (at the resonant frequency) but have a smaller range of frequencies around that frequency for which they resonate; the range of frequencies for which the oscillator resonates is called the bandwidth. High-Q oscillators oscillate with a smaller range of frequencies and more stable. Q-factor is dimensionless parameter that describes how underdamped an oscillator or resonator is and characterizes a resonator's bandwidth relative to its center frequency.

II. RESEARCH METHOD

A. Design and Preparation of Optical Models

The design of the network model will be simulated using Optisystem version 11.1.0.53. In the model, the SOA and FRA optical amplifiers are coupled to the transmission amplifier network (inline amplifier). Figure F.1 shows the design of model, optical fiber communication system.

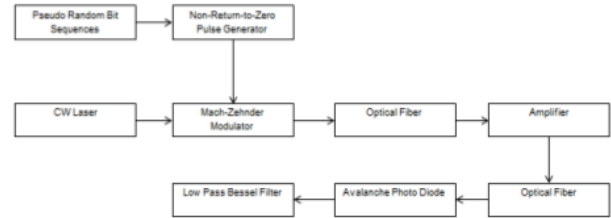

Figure F.1. Model Design with Amplifier

a. Information Source Block

The information source block consists of two components: Pseudo-Random Bit Sequence (PRBS) and Non-Return-to-Zero Pulse Generator (NRZ). PRBS functions to generate bits with specific patterns and speeds. Then the bit that has been generated by PRBS will be encoded using NRZ coding technique. NRZ coding technique has the advantage, that is more resistant to noise and is not affected by the voltage level. Figure F.2. is the planning drawing for the source of pulse information.

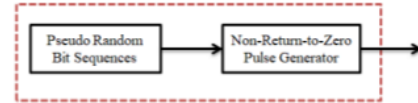

Figure F.2. Information Source Block

b. Transmitter Block

The Transmitter Block (Figure F.3) consists of two components: the laser and the modulator. The laser acts as a light signal generator on a network system. The type of laser used is a Continuous Wave (CW) laser. The modulator used is the Mach-Zehnder Modulator (MZM) which will modulate the coded information signal with the output signal laser.



Figure F.3. Information Source Block

c. Transmission Media Block

The transmission medium (F.4) on this optical network uses single mode optical fiber, because it has a wide bandwidth and a considerable range. In order for the transmitted signal to reach a considerable distance then it requires an optical amplifier, SOA and FRA. Type of TRD used is Average Power Model Amplifier (APA).



Figure F.4. Information Source Block

d. Receiver Block

The Receiver block consists of two components: a detector and a filter. The detector used is Avalanche Photo Diode (APD) as shown in Figure F.5, because it has a faster response and higher gain. The already converted information signal will be forwarded to the filter. The working principle of this filter passes a certain frequency and dampens other frequencies. The type of filter used is the *Low Pass Bessel Filter*.

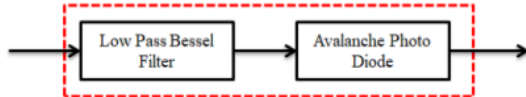

Figure F.5. Information Source Block

B. Work Procedures of SOA and FRA Design

The stages of this procedure begin with a preliminary simulation process that aims to determine the maximum transmission distance of signal propagation on the optical fiber without any gain. In the simulation process it will iterate on the optical fiber, for 30 iterations and each iteration is 10 km. Then, the determination of maximum transmission distance is demonstrated by using SOA and FRA. The working procedure of these two optical amplifiers can be seen in Figure F.6 and F.7.

C. Result and Simulation of Bit Error Rate and Q-Factor

The length of fiber optics greatly affects the performance of a communication system. In determining the maximum transmission length, the parameters that play an important role are the Bit Error Rate (BER) and Q factor. According to the rules of the International Telecommunications Union (ITU-T G.691; ITU-T G.692; ITU-T G.693), the BER requirements for optical communication systems must be better than 10^{-12} , meaning that the minimum value of BER system should be smaller from 10^{-12} . Q-factor is a quality factor that will determine the quality of a link. In a fiber optic communication system, the minimum size of a good Q-factor is 6.

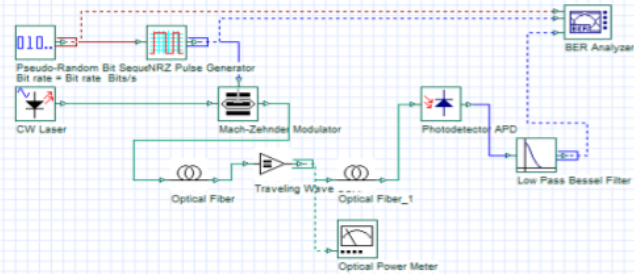

Figure F.6. Optical Fiber System Scheme with SOA Inline-Amplifier

The power consumption of the amplifier will be measured using the Optical Power Meter contained in the circuit. Then

we will also see the influence of the wavelength on the maximum transmission distance of the system.

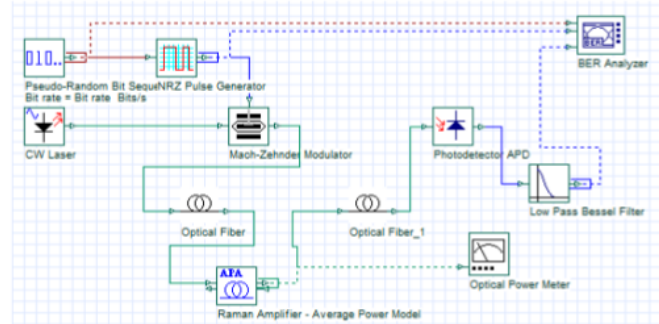

Figure F.7. Optical Fiber System Scheme with FRA Inline-Amplifier

III. RESULT AND DISCUSSION

The result of SOA is depicted in Figure F.8. The BER may be analyzed using stochastic computer simulations. If a simple transmission channel model and data source mode is assumed, the BER may also be calculated analytically. In absence of available device for BER analysis, OTDR has been used for checking the signal loss in fiber optics and the OptiSystem for analyzing the BER. The circuit diagram of Figure F.6 has been used to do this analysis. BER is found in SOA where 1350nm wavelength with 1mW input power is better than the others since it has higher energy rather than 1470nm and 1560nm, so that BER oscillation depends on energy. However, after about 150km, BER value increases. It is not surprising when the distance is long then the error will come, this is due to attenuation of geometry length where it can operate either low or high energy sources corresponding to wavelength source. Even at 120km, the highest BER is achieved for 1350nm (highest energy). This is the weaknesses of SOA characteristics.

Although these data are unknown source of factors but improving BER can be detected by choosing strong signal strength, a slow and robust modulation scheme or line coding scheme, or by applying channel coding schemes such as redundant forward error correction codes.

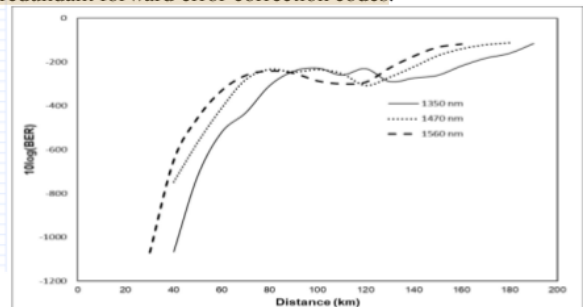

Figure F.8. BER for SOA

As well as BER of SOA, Q-factor of SOA goes down as a distance is increased. But, Q-factor for 1350nm (highest energy) even is less decay rather than the others. Although the decay trends are stable beginning from 80km similar to a constant Q-factor. At 140km the energy source is not good enough to maintain the oscillation source hence the decay goes down near linear including 1350nm and keep maintaining to reduce it slowly.

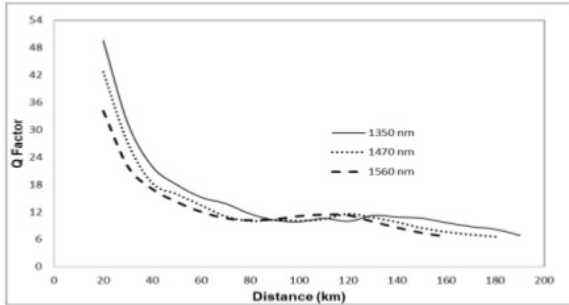

Figure F.9. Q-factor of SOA

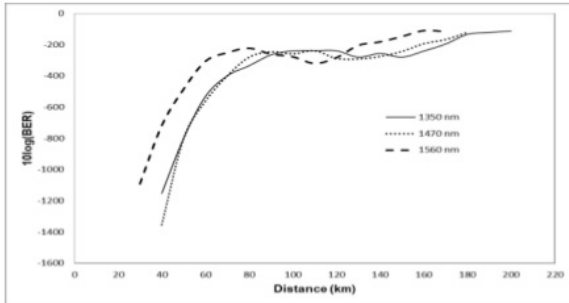

Figure F.10. BER for FRA

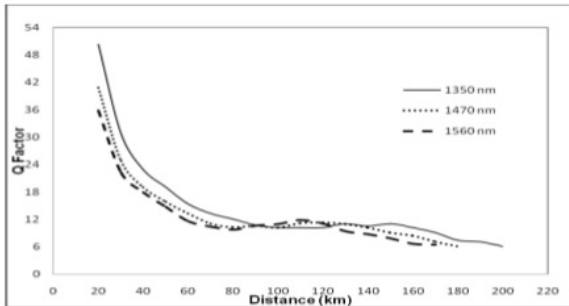
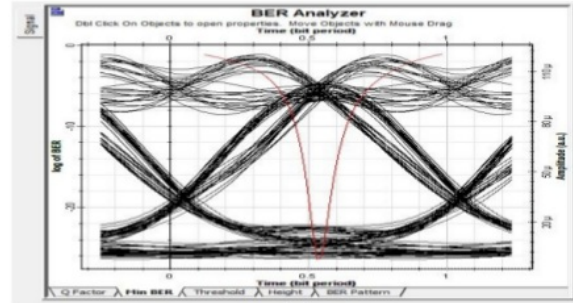

Figure F.11. Q-factor of FRA

Unlike SOA, FRA has good performance for both BER and Q-factor. The result of FRA for BER and Q-factor is depicted in Figure F.10 and F.11. BER is less fluctuated and more stable for higher energy of $E=hf$, where f is frequency source, h is Planck constant and E is energy. From 60 until 140km, BER is nearly constant for various wavelength source,

hence this BER is better than SOA. Q-factor is faster for a stable condition at higher energy at 80km and continues after 160km. This performance shows that at wavelength of 1350nm, the dispersion is more than wavelength of 1560nm but Q factor oscillation is low.



(a)

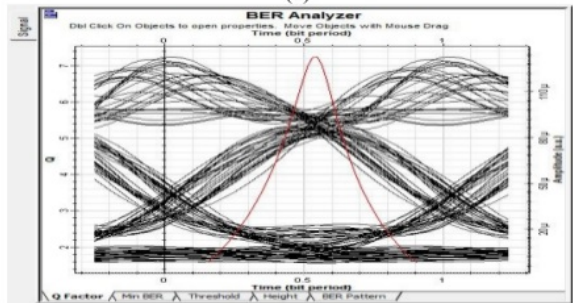

(b)

Figure F.12. (a). 1350nm, 85km, (b). 1560nm, 85km

Figure F.12. is an eye pattern diagram with no amplifier. It is generally seen that the amplitude and bit error rate differ greatly at the lower distances at (a) than (b). The weakness of the unfocused amplitude due to the power and geometry of the far wave from the wave source. The red line facing at below is BER and the red line facing a top is Q-factor.

In Figure F.13, both wavelengths at 160km distance have a low Q-factor especially at low wave energy. SOA function is very effective at a distance less than 100km, but at the peak of 160km, the wave amplitude is not focused anymore. Amplitude is affected by distance even if SOA is used.

Figure F.14 is somewhat different than SOA. FRA has a more effective BER and Q-factor. At a distance of less than 90km the very sharp eye pattern at 1350nm wavelength is almost equal to the 1560nm wavelength. The value of FRA at a distance of 170km is still more effective than on SOA values both at 1350nm and at 1560nm. However at 1560nm, BER is more sharp as Q-factor as well. BER and Q-factor at 1560 is higher so that the amplifier function is weak especially at great distances.

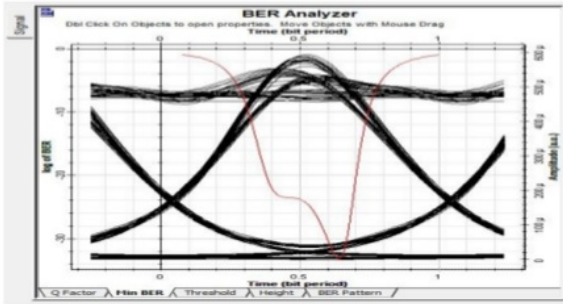

(a)

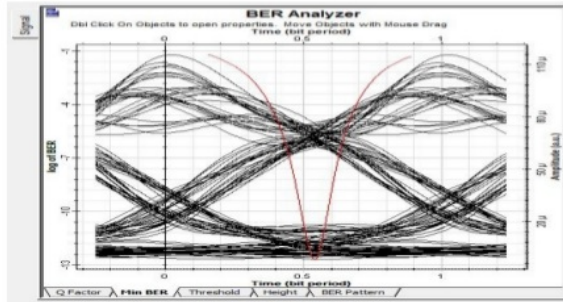

(b)

Figure F.13. (a). SOA (BER and Q-factor) 1350nm, 80km,
 (b). SOA (BER and Q-factor) 1560nm, 160km

IV. CONCLUSION

Although the optical amplifier can maintain the signal along the trajectory of waveguide, several amplifiers still have problems. Both SOA and FRA have advantages and disadvantages. Using the simulation application, both amplifiers are successfully designed and compared by inline amplifiers. The results described that the transmission distance of the FRA is much farther than the SOA shown by BER and Q-factor. However, this FRA system has higher power consumption when compared to the SOA system.

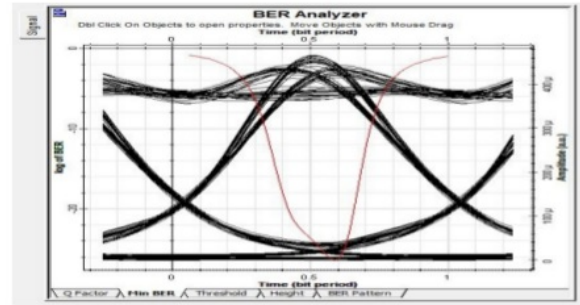

(a)

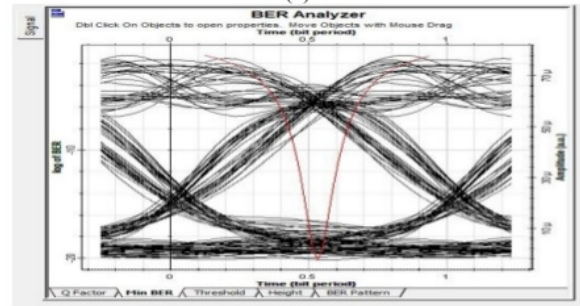

(b)

Figure F.14. (a) Raman (BER, Q-factor) 1350nm, 90km,
 (b). Raman (BER and Q-factor) 1350nm, 170km

REFERENCES

- [1] Karimah Z N, Hambali A, Suwandi. Analisis Perbandingan Kinerja Mach-Zehnder berdasarkan Ragam Format Modulasi pada Jaringan FTTH. *Jurnal ELKOMIKA*. 2017; 5(1): 73-92
- [2] Leuthold J, Bonk R, Vallaitis T, Marculescu A, Freude W, Meuer C, Bimberg D, Brenor R, Lelarge F, Duan G H. *Linear and Nonlinear Semiconductor Optical Amplifiers*. Conference on Optical Fiber Communication (OFC/NFOEC), collocated National Fiber Optic Engineers Conference. San Diego. 2010
- [3] Sun H, Wang Q, Dong H, Dutta N K. XOR Performance of a Quantum Dot Semiconductor Optical Amplifier based Mach-Zehnder Interferometer. *Optics Express*. 2005; 13(6): 1892-1899
- [4] Hamie A, Sharaiha A, Guegan M, Pucel B. All-Optical Logic NOR Gate Using Two-Cascaded Semiconductor Optical Amplifiers. *IEEE Photonics Technology Letters*. 2002; 14(10): 1439-1441
- [5] Kanellos G T, Petrantonakis D, Tsiokos D, Bakopoulos P, Zakyntinos P, Pleros N, Apostolopoulos D, Maxwell G, Poustie A, Avramopoulos H. All-Optical 3R Burst-Mode Reception at 40 Gb/s Using Four Integrated MZI Switches. *Journal of Lightwave Technology*. 2007; 25(1): 184-192
- [6] Dong J, Zhang X, Fu S, Xu J, Shum P, Huang D. Ultrafast All-Optical Signal Processing Based on Single Semiconductor Optical Amplifier. *IEEE Journal of Selected Topics in Quantum Electronics*. 2008; 14(3): 770-778
- [7] Bromage J. Raman Amplification for Fiber Communications Systems. *IEEE Journal of Lightwave Technology*. 2004; 22(1): 79-93.

Performance control of semiconductor optical amplifier and fiber raman amplifier in communication system

ORIGINALITY REPORT

18%

SIMILARITY INDEX

15%

INTERNET SOURCES

11%

PUBLICATIONS

%

STUDENT PAPERS

PRIMARY SOURCES

1	en.m.wikipedia.org Internet Source	2%
2	www.timbercon.com Internet Source	2%
3	journal.uad.ac.id Internet Source	2%
4	Ruchi Varshney, Parag Jain, Sandip Vijay. "Massive MIMO Systems In Wireless Communication", 2018 2nd International Conference on Micro-Electronics and Telecommunication Engineering (ICMETE), 2018 Publication	2%
5	ijarece.org Internet Source	2%
6	sbsstc.ac.in Internet Source	1%
7	doras.dcu.ie	

1%

8

Matthias Wrobel. "Acoustic hybrid sensor for BDV monitoring in insulating oil", 2017 IEEE International Ultrasonics Symposium (IUS), 2017

Publication

1%

9

Zhang, Fan, Xinhong Zhang, Kui Cao, Duoyi Li, and Congcong Li. "Information theory applications in error bit rate analysis of digital image watermarking", Computers & Electrical Engineering, 2012.

Publication

1%

10

"Table of contents", 2018 19th IEEE/ACIS International Conference on Software Engineering, Artificial Intelligence, Networking and Parallel/Distributed Computing (SNPD), 2018

Publication

1%

11

biosains.mipa.uns.ac.id

Internet Source

1%

12

www.itu.int

Internet Source

<1%

13

www.china-cable-suppliers.com

Internet Source

<1%

14

Internet Source

<1%

15

Naohiro Ishii. "Surface Problems in Information Science Keynote Address", 2018 19th IEEE/ACIS International Conference on Software Engineering, Artificial Intelligence, Networking and Parallel/Distributed Computing (SNPD), 2018

Publication

<1%

16

Saktioto, Rosmeri, Okfalisa, Muhammad Hamdi. "Numerical simulation to design single mode fiber coupler with fiber Bragg grating combination", 2017 5th International Conference on Cyber and IT Service Management (CITSM), 2017

Publication

<1%

Exclude quotes On

Exclude matches Off

Exclude bibliography On