

Application of FEM in Investigating Machining Performance

Hendri Yanda^{1, a}, Jaharah A. Ghani^{2, b}, Che Hassan Che Haron^{3, c}

^{1,2,3}Department of Mechanical and Materials Engineering,

Faculty of Engineering and Built Environment, Universiti Kebangsaan Malaysia,
Bangi, Selangor Darul Ehsan, 43600 Malaysia

^aHyanda@eng.ukm.my, ^bjaharah@eng.ukm.my, ^cchase@eng.ukm.my

Keywords: Finite element method, machining performance, rake angle, clearance angle.

Abstract. The two biggest problems that often experienced in machining cast iron are poor machinability and high hardness. Up to now, many researchers have investigated machining performance and how to find optimum condition in machining ductile cast iron. This study aims to investigate the machining performance of ductile cast iron and carbide cutting tool using FEM. Performances were evaluated by changing the cutting tool geometries on the machining responses of cutting force, stress, strain, and generated temperature on the workpiece. Deform-3D commercial finite element software was used in this study. Ductile cast iron FCD 500 grade was used as the work piece material and carbide insert DNMA432 type with WC (Tungsten) was used for the cutting tool. The effects of rake and clearance angles were investigated by designing various tool geometries. Various combination of carbide insert geometries were designed using Solid Work to produce +15, +20 and +30 deg for rake angle and 5, 7, 8 and 9 deg for clearance angle. Machining condition for the simulations were remained constant at cutting speed of 200 m/min, feed rate of 0.35 mm/rev, and depth of cut of 0.3 mm. The results of effective-stress, strain and generated temperature on both chip and material surface were analysed. The results show that by increasing the rake angle (α), it will improves the machining performance by reducing the cutting force, stress, strain and generated temperature on surface of workpiece. But, by increasing the clearance angle (γ), it will not affect much to the cutting force, stress, strain and generated temperature on chip.

Introduction

Finite Element Analysis (FEA) technique was the first introduced in 1960s and still widely used for analysis such as in tools design and forming processes. Based on the success of FEM simulations for bulk forming processes, many researchers developed their own FEM codes to analyze metal cutting processes during the early 1980s up to now [1], [2], [3], [4] and [5]. Cerenitti et al. [1] assumed a rigid sharp tool and elasto-plastic workpiece, and defined a node separation criterion based on the geometry of the element approaching the cutting edge. Cerenitti et al. [1] used an early version of a commercial implicit FEM code "DEFORM-2DTM". This code uses four-node quadrilateral elements and is based on static Lagrangian formulation. Today, DEFORM-3DTM code is commonly used by researchers and industry in machining simulation [6].

Applications of FEM models for machining can be divided into six groups: 1) tool edge design, 2) tool wear, 3) tool coating, 4) chip flow, 5) burr formation and 6) residual stress and surface integrity. The direct experimental approach to study machining processes is expensive and time consuming. For solving this problem, the finite element methods are most frequently used. Modeling tool wear using FEM has advantages over conventional statistical approach because it requires less experimental effort and it provides useful information such as deformations, stresses, strain and temperature in chip and the workpiece, as well as the cutting force, tool stress and temperature on the tool working under specific cutting parameter [7]. This paper presents the application of FEM in studying the effect of tool geometries in turning ductile cast iron FCD 500 on the machining performance of cutting force, stress, strain, and generated temperature.

Methodology

Orthogonal Cutting Condition Model. One of the important parameters in the orthogonal metal cutting process is the rake angle between the face of the cutting tool and the plane perpendicular to the cutting direction. The magnitudes of tool cutting geometries have significant effects on the performance of the cutting tool and the integrity of the cut surface. The main objective of this research is to apply the finite element method to study the rake angle and clearance effects in orthogonal metal cutting of ductile cast iron with continuous chip formation, while the other machining parameters of cutting speed, feed rate and depth of cut were kept constant. Finite element simulation results of the orthogonal metal cutting using three sets of perfectly sharp cutting tools with positive rake angles of 15, 20 and 30° and four clearance angles of 5, 7, 8 and 9 respectively. The commercial software Deform-3D for deformation analysis was used to simulate orthogonal metal cutting process. It is based on an updated Lagrangian formulation and employs an implicit integration scheme. Fig. 1 shows the schematic of orthogonal cutting condition model.

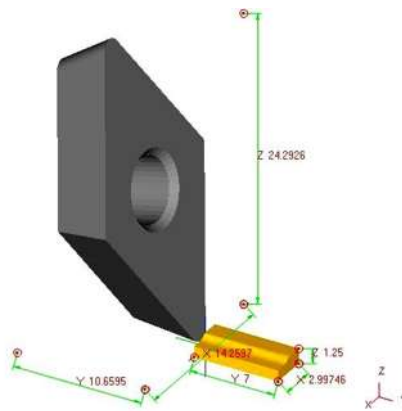

Fig. 1 Schematic of orthogonal cutting condition model

Parameter Inputs and Cutting Conditions. The three-dimensional finite element model was generated under a plane strain assumption because the width of cut was larger than the undeformed chip thickness in this orthogonal cutting arrangement. The flow stress behavior of the work material and the contact conditions were used as equation for flow stress σ models, $\sigma = \sigma_1 \varepsilon^n$ [8]. Cutting conditions are predefined are shown in Table 1.

Table. 1: Parameter inputs in the simulation process

Parameters												
Cutting speed	constant at 200 m/min											
Feed rate	constant at 0.35 mm/rev											
Depth of cut (DOC)	constant at 0.3 mm											
Rake angle (α), deg	15				20				30			
clearance angle (β), deg	5	7	8	9	5	7	8	9	5	7	8	9

The workpiece material was ductile cast iron FCD500 grade. This material was selected as the workpiece material in this study because it was widely used in automotive application. Deform-3D software was used to simulate the effect of tool cutting geometries in turning ductile cast iron using uncoated carbide cutting tool. The simulations were performed by changing the rake angle and clearance angle while the cutting speed, feed rate and depth of cut were kept constant at 200 m/min, 0.35 mm/rev and 0.3 mm respectively. The simulation results of cutting force, effective-stress, strain and generated temperature on the workpiece surface were studied and analyzed. The operation is simulated using insert carbide of DNMA432 type that has a nose angle of 55 deg and without the use of coolant. The tool was defined to be a rigid body which considers thermal transfer

for modeling the cutting temperature field. Cutting condition, simulation models and material properties of carbide cutting tool and workpiece are shown in Table 2.

Table 2: Cutting condition to the simulation models and material properties

Tool geometry of DNMA 432	
Side Cutting Edge Angle (SCEA), deg	-3
Back Rack angle (BR), deg	-5
Side Rack angle (SR), deg	-5
Nose angle, deg	55
Tool properties (WC as base material, uncoated carbide tool)	
Modulus young (GPa)	650
Thermal expansion	5e-06
Poisson ratio	0.25
Boundary condition	
Initial temperature, deg. C	20
Shear friction factor	0.6
Heat transfer coefficient at the interface, N/s mm ^o C	45
Workpiece geometry	
Depth of cut, mm	0.3
Width of cut, mm	3.4
Length of workpiece, mm	7
Workpiece properties (Ductile cast iron FCD500)	
Modulus elasticity (GPa)	169
Thermal conductivity (W/m. °C)	35.2
Thermal expansion coefficient ($\cdot 10^{-6} \text{ }^{\circ}\text{C}^{-1}$)	12.5
Heat capacity (N/mm ² °C)	3.7
Emissivity	0.95

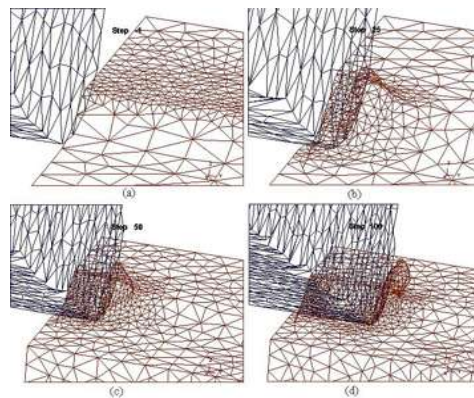

Fig. 2 (a) Initial mesh and tool indentation, (b) Chip formation at step 25, (c) Chip formation at step 50, (d) Developed continues chip at step 100.

Displacement, shape and surface mesh of the tool and workpiece at the initial mesh of beginning the cutting operation was developed until chip formation reach step 100 as illustrated in Fig. 2a , 2b, 2c and 2d respectively. The workpiece and the tool are characterized by non uniform mesh distribution in the simulation. Very small element is required in the contact area between tool and workpiece because of very large temperature gradient and stress that will develop in this region during the simulation.

Design of Cutting Tool Geometries. Cutting tools were designed for various rake angles of +15, +20 and +30 deg and the clearance angles of 5, 7, 8 and 9 deg. There are twelve combinations of geometry designs for carbide tool using Solid Work software as shown in Fig 3.

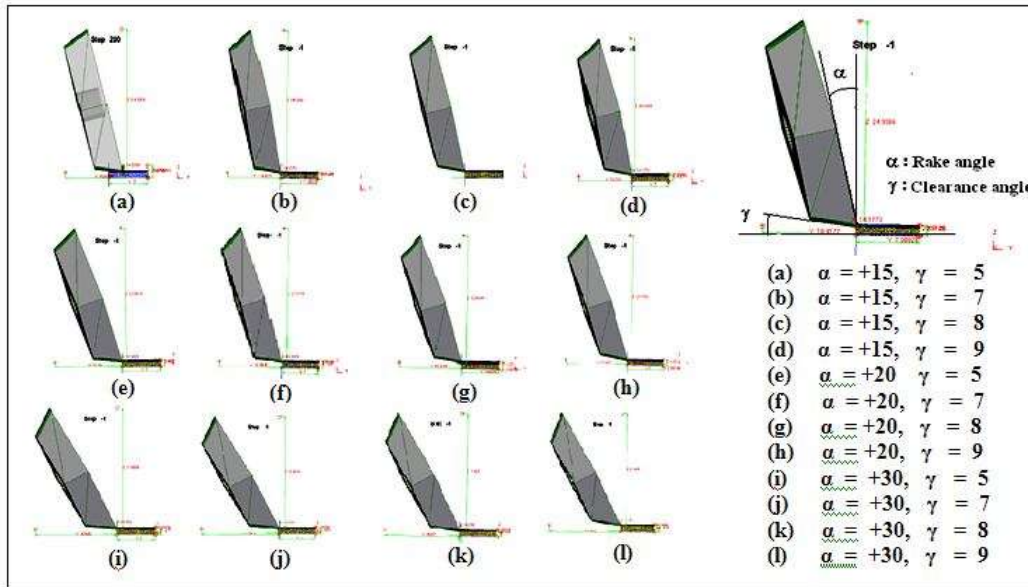

Fig. 3 Modeling for 12 combinations of geometry designs of rake and Clearance angle for DNMA carbide tool cutting

Simulation Results and Discussion

Primary and Secondary Deformation Zone. Fig. 4 shows the simulation results for displacement, cutting force, effective stress, strain and generated temperature for rake angle of +20 deg and clearance angle of 5 deg (cutting speed of 200 m/min, feed rate of 0.35 mm/rev and DOC of 3 mm)

The biggest displacement was reached around 2.84 mm in total displacement at the end of chip formation (Fig. 4a). The biggest deformation was occurred on the primary deformation zone, followed by the secondary deformation zone. This also causes higher stress occurred on this area, about 3565 MPa in primary shear zone (Fig.4b). These results are agreeable with Kalthori [9], where the major deformation during cutting process were concentrated in two region close to the cutting tool edge, and the bigger deformation were occurred in the primary deformation zone, followed by secondary deformation zone, sliding region and sticking region.

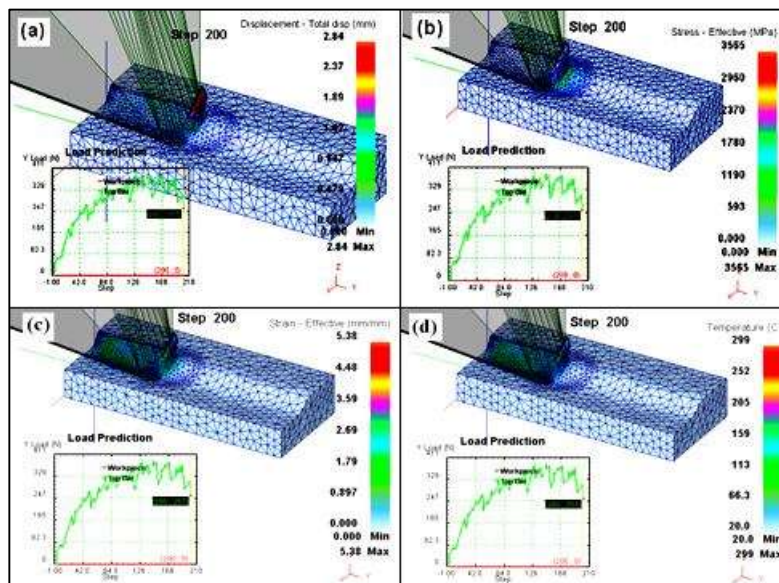

Fig. 4 Simulation results for cutting speed of 200 m/min, rake angle of +20 deg and clearance angle of 5 deg), a) Displacement, b) Effective stress, c) Effective Strain and c) Generated temperature.

Fig. 4c shows the highest effective strain occurred on primary shear zone about 5.03 mm/mm, and then followed by secondary shear zone about less than 2.69 mm/mm. And, the highest temperature was occurred at sliding region on primary shear zone around 299 °C as shown in Fig 4d. Table 3 shows the simulation results for all various rake and clearance angle where cutting speed, feed rate and depth of cut (DOC) that were kept constant at 200 m/min, 0.35 mm/rev and 3 mm respectively.

Table 3: The result of simulation for cutting force, stress, strain, and temperature

No	Rake angle[α]	Clearance Angle [β]	Cutting Speed [m/min]	Feed [mm/rev]	DOC [mm]	Cutting Force [N]	Stress [MPa]	Strain [mm/mm]	Temp [°C]
1	+15	5	200	0.35	3	346	4320	6.11	321
2	+15	7	200	0.35	3	347	4230	6.56	318
3	+15	8	200	0.35	3	400	4195	6.24	334
4	+15	9	200	0.35	3	402	4340	7.13	304
5	+20	5	200	0.35	3	239	3565	5.03	299
6	+20	7	200	0.35	3	295	3690	4.96	304
7	+20	8	200	0.35	3	271	3690	5.56	272
8	+20	9	200	0.35	3	297	3720	5.65	263
9	+30	5	200	0.35	3	165	3360	4.31	198
10	+30	7	200	0.35	3	178	3540	4.45	206
11	+30	8	200	0.35	3	196	3537	5.07	218
12	+30	9	200	0.35	3	262	3400	4.68	225

The Effect of Rake Angle (α). By increasing the rake angle, effect on the cutting force, stress, strain and generated temperature are decreasing as shown in Fig. 5a, 5b, 5c and 5d respectively. For example, increasing the rake angle from +15 deg to +20 deg, will reduce the cutting force from 346 N to 239 N, stress from 4320 MPa to 3565 MPa, strain from 6.11 to 5.03 mm/mm and temperature from 321 °C to 299 °C. This can be accepted that the reducing in cutting force, stress, strain and temperature were resulted from reduction of tool/chip contact area, so the cutting force and friction are expected to be decreased. This is agreeable with theory and experiment done by Gunay et al [10].

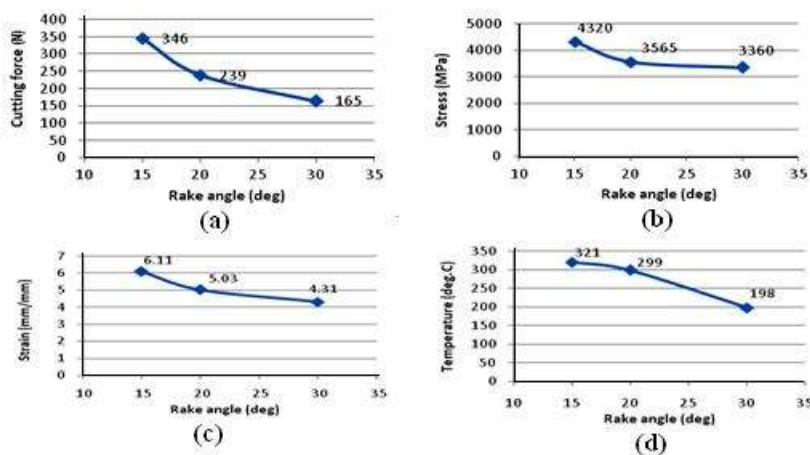

Fig. 5 Effect of rake angle, (a). rake angle vs cutting force, (b). rake angle vs stress, (c). rake angle vs strain, and (d). rake angle vs

The Effect of Clearance Angle (γ). The increase of clearance angle does not much influence the cutting force, stress, strain and generated temperature as shown in Fig. 6a, 6b, 6c, and 6d. All of these results were also agreeable with the theory, because the change of clearance angle will not affect the cutting force and stress, but the increase of clearance angle only affects slightly on the wear rate. Clearance angle will affect wear and tool life of the cutting tool because the clearance

face will rub against the freshly cut metal surface. In industry, the clearance angle is varied, but often in the order of 6 – 10 deg [11].

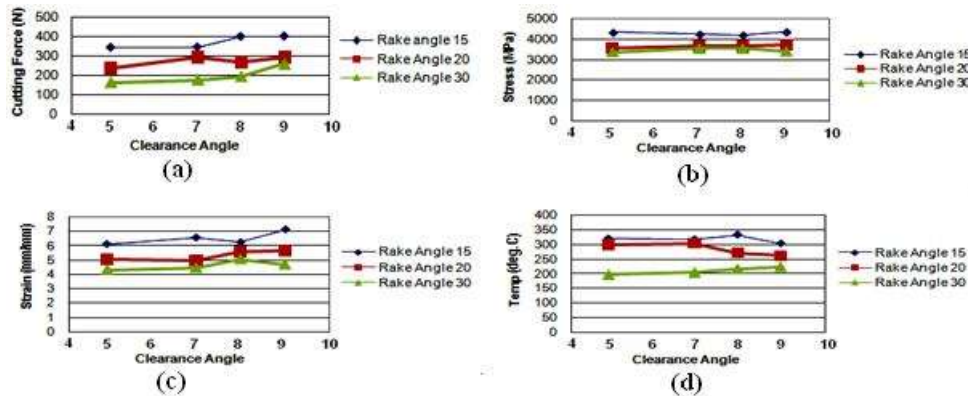

Fig. 6 Effect of clearance angle, (a) clearance angle vs cutting Speed, (b) clearance angle vs stress, (c) clearance angle vs strain, (d) clearance angle vs temperature.

Conclusion

The distribution of cutting force, effective stress and generated temperature obtained from simulations are agreeable with the results given in literature. From the simulation, it can be concluded that increasing the rake angle (α) in the turning of ductile cast iron using tungsten carbide (CW), it will improves the machining performance by reducing the cutting force, stress, strain and generated temperature. But, by increasing the clearance angle (γ), it will not influence much to the cutting force, stress, strain and generated temperature on chip.

References

- [1] T.D. Marusich and Ortiz: Modeling and Simulation of High-Speed Machining, To appear: International Jour. Num. Metallurgy Engineering. (1995).
- [2] A. E. Cerenitti, B.P. Fallbohmer, W. Wu C.W and Altan B.T: Application of 2D FEM to Chip Formation in Orthogonal Cutting, Jour. of materials Processing Technology Vol. 59 (1996), p.169-180.
- [3] J. Q. Xie, A. E. Bayoumi, and H. M. Zbib: FEA Modelling and Simulation of Shear Localized Chip Formation in Metal Cutting, Jour. of Materials Processing Technology Vol. 38 (1998), p.1067-1087.
- [4] C. Shet: Finite Element Analysis of the Orthogonal Metal Cutting Process, Jour. of Materials Processing Technology Vol. 105 (2000), p. 95-109
- [5] A.E.Cerenitti, C.Lazzaroni, L.Menegardo and B.T.Altan: Turning Simulation Using a Three-Dimensional FEM Code, Jour. of materials Processing Technology Vol. 98 (2000), p.99-103.
- [6] O.H.Columbus, in : *DeformTM - 3D Machining (Turning) Lab*, Scientific Forming Tech. Corporation (2007).
- [7] J. Mackerle: Finite Element Analysis and Simulation of Machining: a Bibliography (1976 – 1996), Jour. of Materials Processing Technology Volume 86 (1999), p. 17-44.
- [8] P. L. B. Oxley, in: *Mechanics of Machining: An Analytical Approach to Assessing Machinability*, Ellis Horwood, Chichester, West Sussex (1989), p. 223–227
- [9] V. Kalhori, in: *Modelling and Simulation of Mechanical Cutting*, Doctoral Thesis, Institutionen for Maskinteknik, Sweden (2001).
- [10] M. G. Gunay, I. Korkut, E. Aslan and U. S. Eker: Experimental investigation of the effect of cutting tool rake angle on main cutting force, Jour. of Materials Processing Technology Vol. 166 (2005), p. 44–49.
- [11] E. M. Trent, in: *Metal Cutting*, Butterworth - Heinmann Ltd, London (1991).

Editorial Board



Subscriptions Get full access For Editors Log in My Co

Full text search... [Advanced](#)

PERIODICALS

- MATERIALS SCIENCE FORUM
- KEY ENGINEERING MATERIALS
- SOLID STATE PHENOMENA
- DEFECT AND DIFFUSION FORUM
- DIFFUSION FOUNDATIONS
- APPLIED MECHANICS AND MATERIALS
- > ADVANCED MATERIALS RESEARCH**
- ADVANCES IN SCIENCE AND TECHNOLOGY
- JOURNAL OF NANO RESEARCH
- JOURNAL OF BIOMIMETICS, BIOMATERIALS, AND TISSUE ENGINEERING
- JOURNAL OF METASTABLE AND NANOCRYSTALLINE MATERIALS
- INTERNATIONAL JOURNAL OF ENGINEERING RESEARCH IN AFRICA
- ADVANCED ENGINEERING FORUM

[Home](#) > [Advanced Materials Research](#) > [Details](#)



Periodical: Advanced Materials Research

ISSN: 1662-8985

About: Advanced Materials Research publishes only complete volumes on given topics, proceedings and complete special topic volumes. **Thus, we are not able to publish stand-alone papers.**

Advanced Materials Research specializes in the very rapid publication of international conference proceedings and stand-alone volumes on topics of current interest in all areas of materials research and related topics.

Authors retain the right to publish an extended, significantly updated version in another periodical.

Indexing: Indexed by Elsevier: SCOPUS www.scopus.com and Ei Compendex (CPX) www.ei.org, Cambridge Scientific Abstracts (CSA) www.csa.com, Chemical Abstracts (CA) www.cas.org, Google Scholar google.com, ISI (ISTP, CPCI, Web of Science) www.isinet.com, Institution of Electrical Engineers (IEE) www.iee.org, etc.

Publishing editor: Thomas Wohlbiel, TTP USA, t.wohlbiel@ttp.net

Subscription: Irregular: approx. 100-150 volumes per year. The subscription rate for **web access is EUR 1177.00 per year**. Standing order price: 20% discount off list price. ISSN print 1022-6680 ISSN cd 1022-6680 ISSN web 1662-8985

Editors: [Editorial Board](#)

Main Themes published in this Periodical

Share:      

Editors

Hu , X.Z.

The University of Western Australia, School of Mechanical and Chemical Engineering; Applied Mechanics & Advanced Materials Group, Perth, Australia, WA 6009;

Lau , A.K.T.

[Send mail](#)

Hong Kong Polytechnic University, Department of Mechanical Engineering; Hung Hom, Kowloon, Hong Kong, China;

Publishing Editor Wohlbiel , T.

[Send mail](#)

105 Springdale Lane, Millersville, United States of America, PA 17551;

Editorial Board

Barton , J.

[Send mail](#)

University of Southampton, School of Engineering Sciences; Highfield, Southampton, United Kingdom, SO17 1BJ;

Cao , P.

[Send mail](#)

University of Waikato, Department of Materials and Process Engineering, Waikato Centre for Advanced Materials; Private Bag 3105, Hamilton, New Zealand, 3240;

Chandra , T.

[Send mail](#)

University of Wollongong, Faculty of Engineering, School of Mechanicals, Materials and Mechatronic Engineering; 33 Bootie Street, Wollongong, Australia, NSW 2522;

Chicinas , I.

[Send mail](#)

Technical University of Cluj-Napoca, Department of Materials Science and Technology; 103-105 Muncii Blv., Cluj-Napoca, 400641, Romania;

Daniel , B.S.S.

[Send mail](#)

Indian Institute of Technology Roorkee, Department of Metallurgical and Materials Engineering, Centre of Nanotechnology; Roorkee, India, 247 667;

Engel , U.

[Send mail](#)

Friedrich-Alexander-Universität Erlangen-Nürnberg, Chair of Manufacturing Technology; Egerlandstrasse 11-13, Erlangen, 91058, Germany;

Evans , S.L.

[Send mail](#)

Cardiff University, Cardiff School of Engineering; Queen's Buildings, P.O.Box 925 Parade, Newport Road, Cardiff, United

Dalian University of Technology, School of Mechanical Engineering; Dalian, Liaoning, China, 116024;

Ibhadode , A.O.A.

[Send mail](#)

University of Benin, Department of Production Engineering, Faculty of Engineering; Benin, Nigeria;

Jha , P.K.

[Send mail](#)

Bhavnagar University, Department of Physics; Bhavnagar, India, 364001;

Kim , J.K.

[Send mail](#)

Hong Kong University of Science and Technology, Department of Mechanical Engineering; Clear Water Bay, Pokfulam Road Kowloon, Hong Kong, China;

Leng , J.S.

[Send mail](#)

Harbin Institute of Technology, Center for Composite Materials and Structures; BLDG. A, Science Park of Harbin Institute of Technology, No. 2 Yikuang Street Nangang DIST., Harbin, Heilongjiang, China, 150080;

Palkowski , H.

[Send mail](#)

Clausthal University of Technology, Institute of Metallurgy; Robert-Koch-Strasse 42, Clausthal-Zellerfeld, 38678, Germany;

Pullin , R.

[Send mail](#)

Cardiff University, Cardiff School of Engineering; Queen's Buildings, P.O.Box 925 Parade, Newport Road, Cardiff, United Kingdom, CF24 3AA;

Sand , W.

[Send mail](#)

University of Duisburg-Essen, Biofilm Centre, Aquatic Biotechnology; Geibelstrasse 41, Duisburg, 47057, Germany;

Schikorra , M.

[Send mail](#)

Technical University of Dortmund, Institute of Forming Technology and Lightweight Construction (IUL); Baroper Street 301, Dortmund, 44227, Germany;

Yin , Y.S.

[Send mail](#)

Shanghai Maritime University, Institute of Marine Materials Science and Engineering; 1550 Harbor Ave, Lingang New City, Shanghai, China, 200135;

Zhang , D.L.

[Send mail](#)

University of Waikato, Waikato Centre for Advanced Materials (WaiCAM), School of Engineering; Private Bag 3105, Hamilton, New Zealand, 3240;

Zhang , T.Y.

[Send mail](#)

Hong Kong University of Science and Technology, Department of Mechanical Engineering; Clear Water Bay, Pokfulam Road Kowloon, Hong Kong, China;

PAPER TITLES

Tool Life in High Speed Turning with Negative Rake Angle, p.1009

Effect of Process Parameters on Abrasive Contamination during Water Abrasive Jet Machining of Mild Steel, p.1015

Experimental and FEM Study of Serrated Chip Formation in High Speed Turning Processes, p.1021

Chemical Wet Etching of Silicon Wafers from a Mixture of Concentrated Acids, p.1027

► Application of FEM in Investigating Machining Performance, p.1033

Numerical, Analytical and Experimental Study of Structural Properties of Cutting Tool in Endmilling Process, p.1039

Surface Integrity of AISI H13 in End Milling and Electrical Discharge Machining Process, p.1044

Evaluation of PVD-Inserts Performance and Surface Integrity when Turning Ti-6Al-4V ELI under Dry Machining, p.1050

Study of Micro-EDM of Tungsten Carbide with Workpiece Vibration, p.1056

[Home](#) > [Advanced Materials Research](#) > [Advances in Materials and Processing Technologies...](#) > [Application of FEM in Investigating Machining...](#)

Paper Title: Application of FEM in Investigating Machining Performance

Periodical	Advanced Materials Research (Volumes 264 - 265)
Main Theme	Advances in Materials and Processing Technologies II
Edited by	M.S.J. Hashmi, S. Mridha and S. Naher
Pages	1033-1038
DOI	10.4028/www.scientific.net/AMR.264-265.1033
Citation	Hendri Yanda et al., 2011, Advanced Materials Research, 264-265, 1033
Online since	June, 2011
Authors	Hendri Yanda , Jaharah A. Ghani , Che Hassan Che Haron
Keywords	Clearance Angle , Finite Element Model (FEM) , Machining Performance , Rake Angle
Price	US\$ 28,-



 [Add to Cart](#)

Abstract

Related Articles

The two biggest problems that often experienced in machining cast iron are poor machinability and high hardness. Up to now, many researchers have investigated machining performance and how to find optimum condition in machining ductile cast iron. This study aims to investigate the machining performance of ductile cast iron and carbide cutting tool using FEM. Performances were evaluated by changing the cutting tool geometries on the machining responses of cutting force, stress, strain, and generated temperature on the workpiece. Deform-3D commercial finite element software was used in this study. Ductile cast iron FCD 500 grade was used as the work piece material and carbide insert DNMA432 type with WC (Tungsten) was used for the cutting tool. The effects of rake and clearance angles were investigated by designing various tool geometries. Various combination of carbide insert geometries were designed using Solid Work to produce +15, +20 and +30 deg for rake angle and 5, 7, 8 and 9 deg for clearance angle. Machining condition for the simulations were remained constant at cutting speed of 200 m/min, feed rate of 0.35 mm/rev, and depth of cut of 0.3 mm. The results of effective-stress, strain and generated temperature on both chip and material surface were analysed. The results show that by increasing the rake angle (α), it will improves the machining performance by reducing the cutting force, stress, strain and generated temperature on surface of workpiece. But, by increasing the clearance angle (γ), it will not affect much to the cutting force, stress, strain and generated temperature on chip.

DAFTAR ISI

TENSILE AND DYNAMIC MECHANICAL BEHAVIOR OF THERMOPLASTIC NATURAL RUBBER (TPNR) NANOCOMPOSITES TREATED WITH ULTRASONIC Mou'ad A. Tarawneh, Sahrim Hj. Ahmad, S.Y. Yahya and Rozaidi Rasid	995
Optimization of Process Parameters on EDM Milling of Stainless Steel AISI 304 AKM Asif Iqbal and Ahsan Ali Khan	1001
PARETO OPTIMIZATION OF ELECTRO DISCHARGE MACHINING OF TITANIUM NITRIDE-ALUMINIUM OXIDE COMPOSITE MATERIAL USING GENETIC ALGORITHM Souren Mitra, Soumya Sarkar, Goutam Paul, D. Bhaduri, Sampad Biswas	1007
Sensing Tool Breakage in Face Milling By Support Vector Machine Yao-Wen Hsueh ^{1, a} and Chan-Yun Yang ^{2, b}	1019
Optimization of Precision Grinding Parameters of Silicon for Surface Roughness Based on Taguchi Method Alao Abdur-Rasheed and Mohamed Konneh	1025
NEW APPROACH IN COST STRUCTURING OF HIGH SPEED HARD TURNING Muataz Al Hazza, Erry Yulian T. Adesta, Delvis Agusman, Agus Geter E. Sutjipto, Muhammad Riza	1031
Tool Life in High Speed Turning With Negative Rake Angle Erry Yulian T. Adesta, Muataz Al Hazza, Delvis Agusman, Muhammad Riza, Affah Mohd Ali	1037
Effect of Process Parameters on Abrasive Contamination during Water Abrasive Jet Machining of Mild Steel Affah Mohd Alia, Ahsan Ali Khanb, Mohammad Yeakub Ali	1043
EXPERIMENTAL AND FEM STUDY OF SERRATED CHIP FORMATION IN HIGH SPEED TURNING PROCESSES U. Umer, L.J. Xie, S.J. Askari, S.N. Danish, S.I. Butt	1049
CHEMICAL WET ETCHING OF SILICON WAFERS FROM A MIXTURE OF CONCENTRATED ACIDS M. R. Ismail ¹ , W. J. Basirun	1055
Application of FEM in Investigating Machining Performance Hendri Yanda, Jaharah A. Ghani and Che Hassan Che Haron	1061
Numerical, Analytical and Experimental Study of Structural Properties of Cutting Tool in Endmilling Process M. Mahdi Abootorabi Zarchi, Hamed Zoghi and M. Reza Razfar	1067
SURFACE INTEGRITY OF AISI H13 IN END MILLING AND ELECTRICAL DISCHARGE MACHINING PROCESS Jaharah A. Ghani, Goh GokYeong and Che Hassan Che Haron	1072
Evaluation of PVD-Inserts Performance and Surface Integrity When Turning Ti-6Al-4v ELI under Dry Machining G.A. Ibrahim, C.H. Che Haron and J.A. Ghani	1078

[Home](#)[Journal Rankings](#)[Journal Search](#)[Country Rankings](#)[Country Search](#)[Compare](#)[Map Generator](#)[Help](#)[About Us](#)

 Show this information in
 your own website

Journal Search

Search query _____

 in **Journal Title**
 Exact phrase

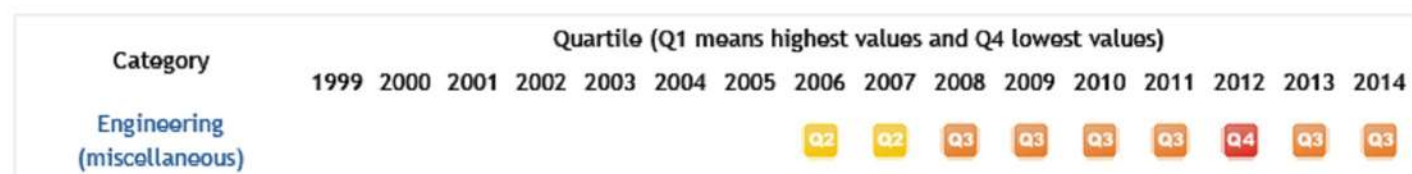
Advanced Materials Research

Country: [Germany](#)**Subject Area:** [Engineering](#)**Subject Category:****Publisher:** [Trans Tech Publications](#). **Publication type:** Book Series. **ISSN:** 10226680**Coverage:** 2005-2014**H Index:** 19**Scope:**

Advanced Materials Research specializes in the very rapid publication of international conference proceedings and stand-alone volumes on topics of current [...]

[Show full scope](#)

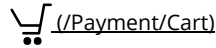

LOG IN
(/ACCOUNT/LOGI
RETURNURL=%2F
265.1033)

Search

Paper Titles



Application of FEM in Investigating Machining Performance

Abstract:



The two biggest problems that often experienced in machining cast iron are poor machinability and high hardness. Up to now, many researchers have investigated machining performance and how to find optimum condition in machining ductile cast iron. This study aims to investigate the machining performance of ductile cast iron and carbide cutting tool using FEM. Performances were evaluated by changing the cutting tool geometries on the machining responses of cutting force, stress, strain, and generated temperature on the workpiece. Deform-3D commercial finite element software was used in this study. Ductile cast iron FCD 500 grade was used as the work piece material and carbide insert DNMA432 type with WC (Tungsten) was used for the cutting tool. The effects of rake and clearance angles were investigated by designing various tool geometries. Various combination of carbide insert geometries were designed using Solid Work to produce +15, +20 and +30 deg for rake angle and 5, 7, 8 and 9 deg for clearance angle. Machining condition for the simulations were remained constant at cutting speed of 200 m/min, feed rate of 0.35 mm/rev, and depth of cut of 0.3 mm. The results of effective-stress, strain and generated temperature on both chip and material surface were analysed. The results show that by increasing the rake angle (α), it will improves the machining performance by reducing the cutting force, stress, strain and generated temperature on surface of workpiece. But, by increasing the clearance angle (γ), it will not affect much to the cutting force, stress, strain and generated temperature on chip.

Info:

Periodical:	Advanced Materials Research (/AMR) (Volumes 264-265)
Main Theme:	Advances in Materials and Processing Technologies II (/AMR.264-265)
Edited by:	M.S.J. Hashmi, S. Mridha and S. Naher
Pages:	1033-1038
DOI:	10.4028/www.scientific.net/AMR.264-265.1033
Citation:	H. Yanda et al., "Application of FEM in Investigating Machining Performance", Advanced Materials Research, Vols. 264-265, pp. 1033-1038, 2011
Online since:	June 2011
Authors:	Hendri Yanda (/author/Hendri_Yanda) , Jaharah A. Ghani (/author/Jaharah_A_Ghani_1) , Che Hassan Che Haron (/author/Che_Hassan_Che_Haron)
Keywords:	Clearance Angle (/keyword/Clearance_Angle) , Finite Element Model (FEM) (/keyword/Finite_Element_Model_FEM) , Machining Performance (/keyword/Machining_Performance) , Rake Angle (/keyword/Rake_Angle)
Export:	RIS (/AMR.264-265.1033.ris) BibTeX (/AMR.264-265.1033.bib)
Price:	€ 32,00
Permissions:	Request Permissions (https://www.copyright.com/OpenURL?Sid=1000009152&issn=1662-8985&WT.mc_id=1000009152)
Share:	

ADD TO CART

References >

Cited by >

Related Articles >

[GET ACCESS \(/ACCOUNT/SUBSCRIPTIONS\)](#)

[SYSTEM GUIDE \(/INFO\)](#)

[DISTRIBUTORS \(/DISTRIBUTOR\)](#)

[SUPPLEMENTS \(/DOWNLOADS\)](#)

[ABOUT US \(/HOME/ABOUTUS\)](#)

[POLICY & ETHICS \(/HOME/MISCONDUCT\)](#)

[CONTACT US \(/HOME/CONTACTS\)](#)

[IMPRINT & PRIVACY POLICY \(/HOME/IMPRINTANDPRIVACYPOLICY\)](#)

[SITEMAP \(/HOME/SITEMAP\)](#)

Scientific.Net is a registered brand of Trans Tech Publications Inc
© 2017 by Trans Tech Publications Inc. All Rights Reserved

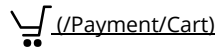

 LOG IN
 (/ACCOUNT/LOG
 RETURNURL=%2F
 

Search

Periodicals >

Advanced Materials Research

ISSN: 1662-8985

 (/AMR/rss)

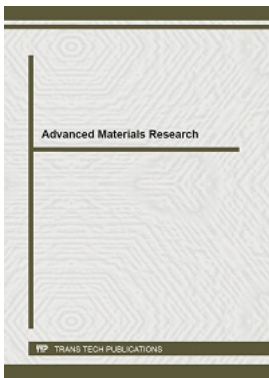
[Volumes \(/AMR\)](/AMR/)
[My eBooks \(/AMR/ebooks\)](/AMR/ebooks/)
[Details \(/AMR/Details\)](/AMR/Details/)
[Editorial Board \(/AMR/Editors\)](/AMR/Editors/)

About:

“Advanced Materials Research” is a peer-reviewed journal which covers all aspects of theoretical and practical research of materials science: synthesis, analysis of properties, technologies of materials processing and their use in modern manufacturing. “Advanced Materials Research” is one of the largest periodicals in the field of materials engineering.

“Advanced Materials Research” specializes in rapid publication of thematically complete volumes from international conference proceedings and complete special topic volumes. We do not publish stand-alone papers by individual authors. Authors retain the right to publish an extended and significantly updated version in another periodical.

Abstracted/Indexed in:

SCImago Journal & Country Rank (SJR) www.scimagojr.com.

Inspec (IET, Institution of Engineering Technology) www.theiet.org.

Chemical Abstracts Service (CAS) www.cas.org.

Google Scholar scholar.google.com.

GeoRef www.americangeosciences.org/georef.

Cambridge Scientific Abstracts (CSA) www.csa.com.

ProQuest www.proquest.com.

Ulrichsweb www.proquest.com/products-services/Ulrichsweb.html.

EBSCO Discovery Service <https://www.ebscohost.com/discovery>.

CiteSeerX citeseerx.ist.psu.edu.

Zetoc zetoc.jisc.ac.uk.

EVISA <http://www.speciation.net/Public/Linklists/EVISA.html>.

Index Copernicus Journals Master List www.indexcopernicus.com.

WorldCat (OCLC) www.worldcat.org.

ISSN print 1022-6680 ISSN cd 1022-6680 ISSN web 1662-8985

Additional Information:

Please ask for additional information: amr@scientific.net (<mailto:amr@scientific.net>)

Subscription

Irregular: approx. 4-6 Volumes per year.

Rates 2018 for:

- Web only: EUR 560,00 per year,

- Print (+free WEB): EUR 560,00 (+Postage EUR 102,00)

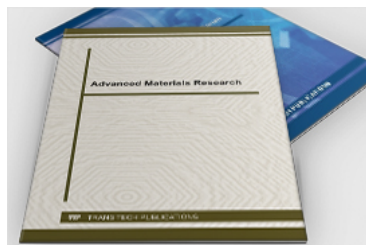

Share:

263

[GET ACCESS \(/ACCOUNT/SUBSCRIPTIONS\)](#)

[SYSTEM GUIDE \(/INFO\)](#)

[DISTRIBUTORS \(/DISTRIBUTOR\)](#)

[SUPPLEMENTS \(/DOWNLOADS\)](#)

[ABOUT US \(/HOME/ABOUTUS\)](#)

[POLICY & ETHICS \(/HOME/MISCONDUCT\)](#)

[CONTACT US \(/HOME/CONTACTS\)](#)

[IMPRINT & PRIVACY POLICY \(/HOME/IMPRINTANDPRIVACYPOLICY\)](#)

[SITEMAP \(/HOME/SITEMAP\)](#)

Scientific.Net is a registered brand of Trans Tech Publications Inc
© 2017 by Trans Tech Publications Inc. All Rights Reserved



Advanced Materials Research

Country	Switzerland
Subject Area and Category	Engineering Engineering (miscellaneous)
Publisher	Trans Tech Publications
Publication type	Book Series
ISSN	16628985, 10226680
Coverage	2005-2014 (cancelled)
Scope	Advanced Materials Research specializes in the very rapid publication of international conference proceedings and stand-alone volumes on topics of current interest in All areas of materials research. Indexed by Elsevier: SCOPUS www.scopus.com and Ei Compendex (CPX) www.ei.org/ . Cambridge Scientific Abstracts (CSA) www.csa.com , Chemical Abstracts (CA) www.cas.org , Google and Google Scholar google.com , ISI (ISTP, CPCI, Web of Science) www.isinet.com , Institution of Electrical Engineers (IEE) www.iee.org , etc. (source)

25

H Index

Quartiles

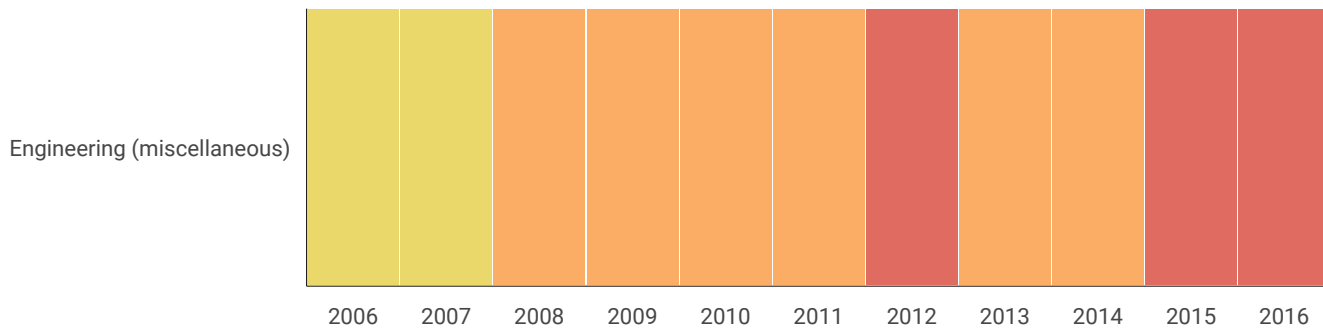

SJR

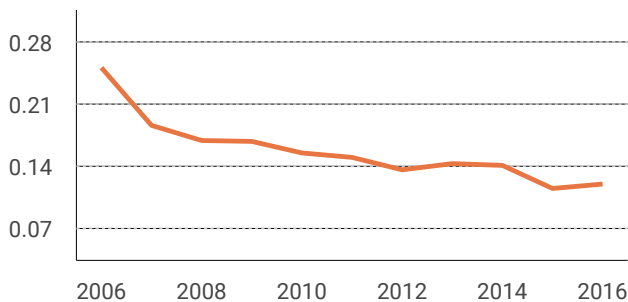

Citations per document



Total Cites Self-Cites



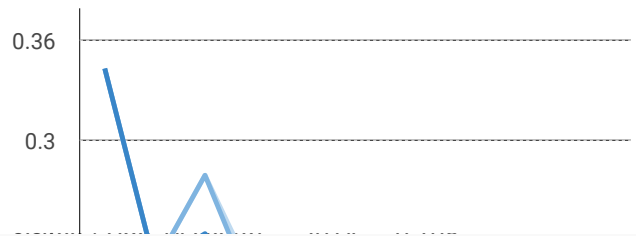
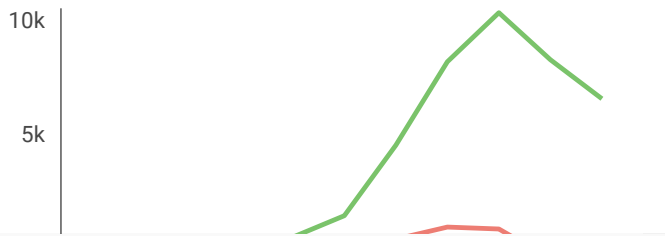

● External Cites per Doc ● Cites per Doc +

● % International Collaboration +

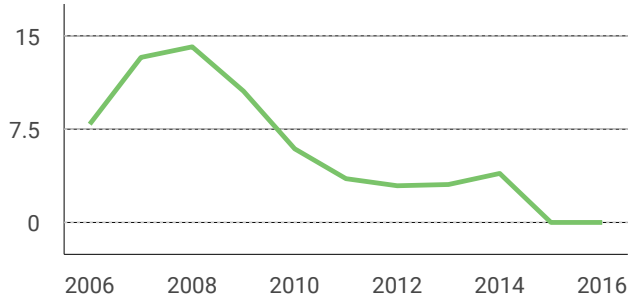
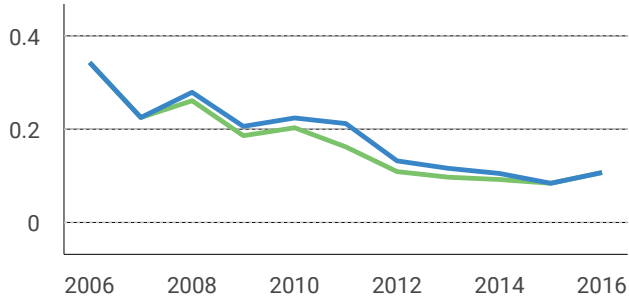

● Citable documents ● Non-citable documents +

● Cited documents ● Uncited documents +

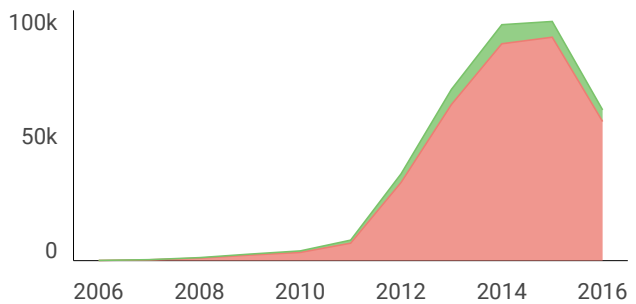
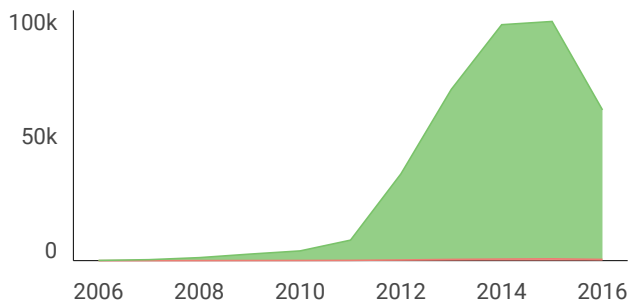

Advanced Materials Research

Indicator	2009-2016	Value
SJR		0.12
Cites per doc		0.12
Total cites		6386

www.scimagojr.com

← Show this widget in your own website

Just copy the code below and paste within your html code:

```
<a href="http://www.scimagr
```

Developed by:



Powered by:



Follow us on Twitter

Scimago Lab, Copyright 2007-2017. Data Source: Scopus®

EST MODUS IN REBUS

Horatio (Satire 1,1,106)

Application of FEM in Investigating Machining Performance

Hendri, Yanda and Jaharah, A. Ghani and Che, Hassan Che Harun *Application of FEM in Investigating Machining Performance*. Application of FEM in Investigating Machining Performance. pp. 1033-1038. ISSN 1662-8985



Text (Application of FEM in Investigating Machining Performance)

Application of FEM in Investigating Machining Performance.pdf

[Download \(1MB\)](#) | [Preview](#)

Abstract

The two biggest problems that often experienced in machining cast iron are poor machinability and high hardness. Up to now, many researchers have investigated machining performance and how to find optimum condition in machining ductile cast iron. This study aims to investigate the machining performance of ductile cast iron and carbide cutting tool using FEM. Performances were evaluated by changing the cutting tool geometries on the machining responses of cutting force, stress, strain, and generated temperature on the workpiece. Deform-3D commercial finite element software was used in this study. Ductile cast iron FCD 500 grade was used as the work piece material and carbide insert DNMA432 type with WC (Tungsten) was used for the cutting tool. The effects of rake and clearance angles were investigated by designing various tool geometries. Various combination of carbide insert geometries were designed using Solid Work to produce +15, +20 and +30 deg for rake angle and 5, 7, 8 and 9 deg for clearance angle. Machining condition for the simulations were remained constant at cutting speed of 200 m/min, feed rate of 0.35 mm/rev, and depth of cut of 0.3 mm. The results of effective-stress, strain and generated temperature on both chip and material surface were analysed. The results show that by increasing the rake angle (α), it will improves the machining performance by reducing the cutting force, stress, strain and generated temperature on surface of workpiece. But, by increasing the clearance angle (γ), it will not affect much to the cutting force, stress, strain and generated temperature on chip.

Item Type: Article

Subjects: [A General Works > AS Academies and learned societies \(General\)](#)
[T Technology > T Technology \(General\)](#)
[T Technology > TA Engineering \(General\). Civil engineering \(General\)](#)

Divisions: [Fakultas Teknik](#)

Depositing User: sry sartika

Date Deposited: 04 Nov 2016 03:01

Last Modified: 04 Nov 2016 03:01

URI: <http://repo.unand.ac.id/id/eprint/3984>

Actions (login required)



View Item