A close-up photograph of an electric vehicle charging cable, showing the metal connector and the braided cable sheath. The image is partially obscured by a semi-transparent grey box containing the title.

COMPARISON OF THE LOW VOLTAGE NETWORK STRUCTURE OF THE DÜSSELDORF UTILITY COMPANY AND THE MADRID UTILITY COMPANY IN RESPECT OF CHARGING ELECTRIC CARS

Autor: Iván Díaz García
Tutor FHD: Prof. Dr-Ing Detmar Arlt
Cotutor UC3M: Prof. Dr-Ing Hortensia Amarís
Coordinador Académico: Sonia Gorriz

Special thanks to my project partner Josefina for her effort and dedication, and to my family and friends for their support. Also thanks to the people from Stadtwerke Düsseldorf, Fachhochschule Düsseldorf University and Universidad Carlos III de Madrid for the assistance.

INDEX

| | |
|---|----|
| 0. Introduction..... | 5 |
| 1.Motivation of this project..... | 7 |
| 2.Electromobility nowadays..... | 10 |
| 2.1.Electromobility in Spain..... | 10 |
| 2.2.Electromobility in Germany..... | 14 |
| 2.3.Brief comparison between the two types of plans..... | 17 |
| 3.Technical details of electric cars..... | 18 |
| 3.1.Types of batteries..... | 18 |
| 3.2.Constructive aspects..... | 26 |
| 4.Comparison of the Medium/Low voltage Network structure of Düsseldorf and Madrid..... | 33 |
| 4.1.M/L Voltage Network Structure of Madrid..... | 33 |
| 4.2.M/L Voltage Network Structure of Düsseldorf..... | 40 |
| 4.3.Comparison..... | 46 |
| 5.Neplan Simulations of power systems with Electromobility..... | 53 |
| 6.Technical requirements of the Network as a result of Electric Cars..... | 61 |

| | |
|--|----|
| 7.Possible final solutions for the operation of Electric Cars..... | 63 |
| 7.1.V2G Networks. Intelligent Networks and Smart Meters..... | 63 |
| 7.2.Electric Car Battery Swap Station..... | 66 |
| 8.Bibliography..... | 68 |
| 9.Acronyms..... | 70 |
| 10. Spanish Abstract..... | 71 |

0. INTRODUCTION

As introduction to our project we will make some brief historical review to see the beginnings of electric car. For this we have built this table where we can see easily the evolution of the Electric Car:

| YEAR | DESIGNER/MAKER | PLACE | FEATURES |
|-------------|---|--------------|---|
| 1828 | Ányos Jedlik | Hungary | Tiny model car powered by an early type of electric motor |
| 1834 | Thomas Davenport | USA | Small model car with short circular electrified track |
| 1835 | Sibrandus Stratingh Christopher Becker | Netherlands | Small-scale EC powered by non-rechargeable primary cells |
| 1838 | Robert Davidson | Scotland | Electric locomotive that attained a speed of 6,4 Km/h |
| 1839 | Robert Anderson | Scotland | Crude Electrical carriage |
| 1865 | Gaston Plante | France | First rechargeable battery |
| 1867 | Franz Kravogl | Austria | Electric powered two-wheel cycle |
| 1881 | Gustave Trouvé | France | Working three wheeled automobile |
| 1884 | Thomas Parker | England | Innovations such as electrifying the London Underground |
| 1899 | Camille Jénatzy | Belgium | “Jamais Contente” |

Among the most notable of these records was the breaking of the 100 km/h (62 mph) speed barrier, by Camille Jénatzy on April 29, 1899 in his 'rocket-shaped' vehicle *Jamais Contente*, which reached a top speed of 105.88 km/h (65.79 mph).

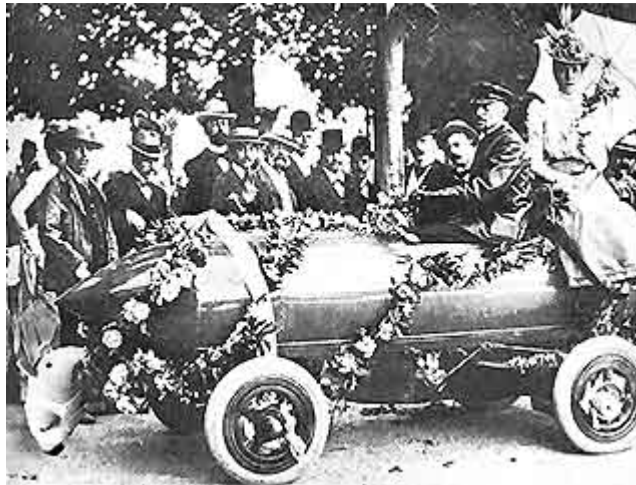

Figure 1: “*La Jamais Contente*”

Source: *Electric and hybrid cars*

On 1930 Electric Cars are extinguished because of the fall in the price of gasoline.

On 1973 General Motors developed an urban electric car with a battery charger, which was presented in USA.

The same company created in 1999 the EV1 model which was the first electric car completely modern, fast, clean, efficient, mechanically simple and with a range of 130 km.

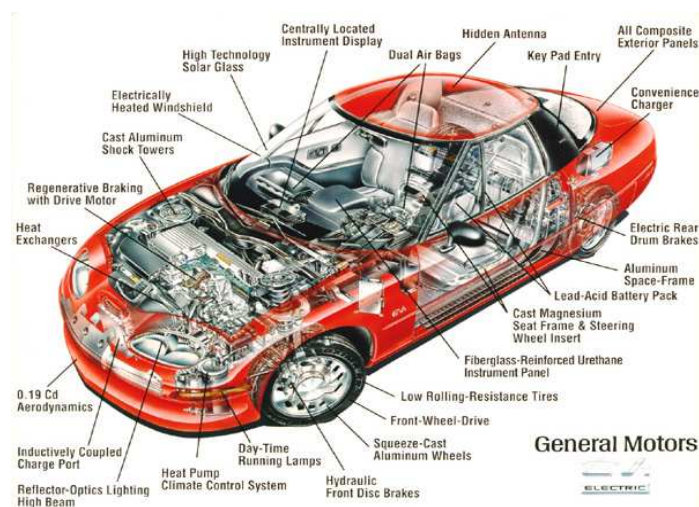

Figure 2: “*EV1*” Source: *General Motors*

1. MOTIVATION OF THIS PROJECT

Nowadays, everybody talk about Electromobility as something revolutionary but distant. Over recent years there has been a given social awareness about global warming due to greenhouse gases. People are aware of the need of changing in order to the current situation does not harm future generations. This has resulted in policies and laws at national and European level, in addition to global agreements like the Kyoto protocol, and more recently the Copenhagen summit. In particular, in Europe, we find an increase in taxes on more polluting vehicles, restrictions on CO2 emissions of new production vehicles, subsidies for vehicles with environmentally friendly, and integration plans electric vehicle.

Electric cars enjoyed popularity between the mid-19th century and early 20th century, when electricity was one of the preferred methods for running cars.

But the electric car was not successful because it had some severe disadvantages:

1. The need to recharge the battery. If you own an electric car need to plan at what moment it is necessary to recharge the battery. Also, if you are thinking of buying an electric car, then you must make an honest assessment of how much you will use your vehicle. An extended or unplanned trip could be problematic if you haven't had time to fully recharge the batteries.
2. The batteries of these cars are very heavy. For example, cell battery pack in a Tesla Roadster can reach up to 450 kilos. This is much weight to carry and reduces the car's efficiency.
3. Electric car price which is high. What makes electric vehicle expensive is the battery. The batteries used in electric cars are lithium-ion, which are expensive. Also keep in mind that the battery will need to be replaced, as they have a life of approximately 3 to 4 years.
4. The autonomy of the electric car. If you drive long distances the electric car may not be able to meet your needs, so you will need to consider how far you plan on driving your car. Most of the electric cars have limits on how many miles they can go before needing a recharge.

Despite these difficulties, the electric car is the car of the future and that is the reason why we consider interesting making a deep study about it.

Electric cars improve energy efficiency, reduce CO₂ emissions and pollutants in the cities and also allows the reduction of oil dependence and use of energy sources indigenous (in the case of Spain involve the use of their sources CO₂-free generation, especially renewable energy which already accounts 20% of electricity generation and in 2020 will involve 40%).

Electric cars have come a long way in recent years but still have to overcome a few more obstacles before becoming widely embraced as a solution for many consumers.

Currently, there is a social awareness to protect the environment and therefore the electric car is an attractive alternative for people so it is important to focus on this issue. Additionally, consumers are also interested in electric cars in the wake of the rising price of gasoline (electricity is cheaper than fuel).

Expect a great change in the automotive industry with the development of electric cars and a great success based on the reduction of pollution, rising gas prices and less dependence on oil. World governments are pledging billions to fund development of electric vehicles and their components.

It is important that the electric vehicle as a new consumer of electricity may become an advantage to operate more efficient electrical system, reducing the large differences that happen between periods of higher and lower power consumption and facilitating the integration of renewable energy. For best operation of the system is very important that the demand shifts towards the peak times, and this is where the nocturnal slow recharge electric car can play a key role in flattening the demand curve.

Also the electric car can be a reversible electric storage system. Batteries should be recharged at night when demand is smaller, and during the day may shed electricity to the network (but this point is yet to be developed).

Thus, improvements to the system by the electric car would be:

1. Contribute to flatten the demand curve, thereby improve system efficiency. For this purpose, consumers would have to recharge their vehicles during lower consumption periods (between 1:00 a.m. and 7:00 am) to reduce the differences in consumption between peak hours and valley hours, thus flattening the demand curve.

2. Renewable energies can easily integrate into the system with security conditions. Wind power energy generation is extremely variable and frequently increases at night, when it is not always possible to integrate this energy generated into the system if the electric energy offer is greater than the electricity demand. For this reason, recharging electric vehicles during night-time hours reduces the possible disconnection of the wind farms should their production exceed the system safety limits which have been set.
3. Thanks to the electric vehicle the countries can reduce its oil dependency for energy and CO₂ emissions, contribute to improving the air quality and reduce the noise levels in cities.

2. ELECTROMOBILITY NOWADAYS

The world of Electromobility has much yet to explore, you could say that today is beginning to “take off”. Lots of plans are being developed by the governments all over the world but in this chapter we will focus in the main strategics plans of Spain and Germany. It is interesting to know that in the Electromobility Guide “Wegweiser Elektromobilität” there is an overview of 150 projects that have been identified in Germany, Europe and on an international scale in the first six months of 2010.

2.1. Electromobility in Spain.

Electric cars are new consumers which come to represent over the next decade 2% of current demand.

According to studies by Red Eléctrica España could be integrated in the coming years to six and a half million electric cars without additional investment in generation or in the transmission if we make a nocturnal slow recharge.

However, we need to develop intelligent charge systems that allow a communication network-vehicle (intelligent networks) and install meters with time discrimination to help users make intelligent recharging. We will see this point deeply in another chapter.

Comprehensive Strategy for the Promotion of Electric Vehicles in Spain:

At the beginning of 2010, some working groups formed by various Spanish companies and institutions gathered for the elaboration of this strategy. These associations are as follows:

MOTOR GROUP: Ministry of Industry, Tourism and Trade, Foundation Institute for Sustainable Technology auto-FITSA, Institute for Diversification and Saving Energy – IDEA.

DEMAND AND PROMOTING GROUP: Acciona, ACS, Asociación Española Renting, Berge Automoción, Citroën, Endesa, Eon, FCC, Gas Natural /Unión Fenosa, HC / EDP, Iberdrola, Iveco, Mercedes, Mitsubishi, Nissan, Peugeot, Race, Renault, Reva, Seat, Tata, Toyota, Vaesa.

INDUSTRIALIZATION, RESEARCH, DEVELOPMENT AND INNOVATION

GROUP: Anfac, Ford, Grupo PSA, Iveco, Mercedes, Nissan, Opel/General, Motors España, Renault, Seat, Sernauto, Volkswagen.

INSTITUTIONAL GROUP: Heads of Government, Home Office, Ministry of Economy and Finance, Ministry of Environment, ministry of Development, Ministry of Science and Innovation, Spanish Federation of Municipalities and Provinces, Autonomous Communities.

The quantitative objective of the Comprehensive Strategy to promote Electric Vehicles is to facilitate the introduction of Electric cars or plug-in, until in 2014 there will be 250000 units of these vehicles in Spain.

In order to achieve this goal, the promotion of Electric Vehicle has to go through four lines of action, in accordance with this strategy.

Inside of these four areas there are programs that define the actions to be taken.

Here is a brief summary of them:

I) Boost demand and the promotion of electric vehicle use:

1.1) Program to boost demand:

It is estimated that if there are 250000 Electric Vehicles in 2014, 85% will belong to companies and public institutions and the remaining 15% will be vehicles for personal use. It aims to provide economic aid to the users of this kind of vehicles and develop plans for this reason (an example is the MOVELE PLAN, which will provide between 750 and 20000 Euros, depending on the type of vehicle, managing to give up to 7000 Euros in case of the electric cars).

1.2) Urban benefits program:

It is intended to give the electric vehicle urban advantages compared to internal combustion vehicles:

- Preferred parking and circulation on public roads.
- Allow the movement of EV in restricted areas of cities.
- Extended hours loading / unloading.
- Reduce Tax Disc.

- Reserve space for quick reloads for emergency vehicles urban fleets serving sensitive areas: medical, police, etc...
- Reserve space for taxi fleets refills when autonomy EV is sufficient to provide this service.

II) The promotion of industrialization and the research, development and innovation for electric vehicle:

II.1) Promotion program of development and industrialization of electric vehicles in Spain, its components and equipment environment:

The purpose of this program is maximize the industrialization of specific components and modules for electric vehicles and plug-in hybrid, both elements characteristic of EV associated with EV (EV communication, infrastructure charging, etc..) and establish production lines of these vehicles on Spanish plants to satisfy, in large measure, the demand will strengthen, not losing, likewise, position as the third European country in the manufacture of automobiles.

II.2) Program of research, development and innovation:

This program aims to provide specific and explicit support in:

- Lines of R + D + i priority to improve the supply of builders and specific components of electric vehicles, and specifically the batteries and battery management systems and control.
- Lines of R + D + i for the development of energy supply infrastructure and load management: intelligent charging, control and communications equipment, etc.
- Lines of R + D + i for the problems related to the life of the vehicle: Security, vehicles out of use (recycled from batteries, motors, etc.).
- Promote centers of excellence for R + D + i EV capable of doing research, testing, standardization, training, etc.

III) The development of freight infrastructure and energetic management:

III.1) Deployment program of burden infrastructure:

About charging points, this program provides that on the horizon of 2014 there will be 62000 points private households, 263000 car fleet points, 12150 points in public parks and 6200 on public roads. It also provides the installation in 2011 of fast-loading point for every 400 vehicle charging point individuals, so that on the horizon 2014, reach 160 stations.

III.2) Management Program of Energy Demand:

The program aims to provide adequate assurance that the cost of electric vehicle energy is significantly lower than cost of the combustion energy. Along with incentives to purchase electric vehicle, this economy makes the market introduction of this new propulsion technology easier.

Ministry of Industry, Tourism and Trade will promote the existence of power deals with the kWh price ranges and articulate legal provisions that promote demand management to take advantage of the benefits when electric vehicle is recharging in times of low electrical consumption.

IV) Horizontal Programs

IV.1) Actions of communication and strategic marketing:

This program focuses on the implementation of communication plans and strategic marketing reporting what is an electric vehicle, its features, its advantages, charging different rates, optimal load times, etc. Implementation, coordination and management of strategic marketing and their communications will be carried out by the Ministry of Industry, Tourism and Trade.

IV.2) Regulatory Activity and Suppression of Legal Barriers:

The aim is to identify and overcome legal barriers that hinder the momentum of demand and the deployment of charging infrastructure. The Directorate General of Industry, Ministry of Industry, Tourism and Trade, with the associated organization of this Technological Institute Foundation Sustainability Motor-Fits-and with the involvement of two groups of work or specific interest (Manufacturers and energy services industry) identify the needs to amend the regulations and laws that are apply to these vehicles, and charging infrastructure.

IV.3) *Promotion of Specific and Specialized vocational Training*

This section will attempt to identify and propose a catalog of courses required for development and manufacture of electric vehicles, and for maintenance, repair and recycling and for those professionals who, for their safety, will require minimum knowledge. The ongoing identification of these specific needs and knowledges will be conducted by training, business and technology organizations.

In order to continuously monitor the objectives achieved and try to solve the problems encountered, a group of Monitoring will be created and managed by the Ministry of Industry, Tourism and Trade and will be formed by the Ministry of Energy and the General Secretariat Industry through the DGs that they designate, and may part of the same institutions and companies that are considered necessary for it. They are invited by the Ministry of Industry, Tourism and Trade for this purpose and the Ministry of Environment and the Ministry of Science and Innovation support participating in the development of the Comprehensive Strategy Impetus to electric vehicle.

Also there will be a specific follow-up to Promote Electric Vehicle with Autonomous Communities in the framework of the Conference and Industry Sector Energy (C.S.I.E).

2.2. Electromobility in Germany.

A strategic plan was created in August 2009 and claims that Germany is a leader in Electromobility and that in 2020 a million of these electric vehicles will be circulating in Germany. Let's see a brief summary of this plan in accordance with the information extracted directly from the German Federal Government's National Development Plan Electromobility:

German Federal Government's National Electromobility Development Plan:

The German Federal Government's Integrated Energy and Climate Programme cites Electromobility as a major component and its implementation report calls for drafting a National Electromobility Development Plan.

Electromobility is therefore an issue of major strategic importance for the German Federal Government, as stipulated in the Integrated Energy and Climate Programme in combination with energy supply from renewable sources. The responsible ministries, the Federal Ministry of Economics and Technology (BMWi), the Federal Ministry of Transport, Building and Urban Affairs (BMVBS), the Federal Ministry for the Environment, Nature Conservation and Nuclear Safety (BMU) and the Federal Ministry of Education and Research (BMBF) entered into intensive joint dialogue with the business and science community to discuss the challenges and opportunities and draft guidelines for implementing the ten-year plan to achieve its Electromobility goals.

The activities and measures of the German Federal Government are based on a variety of ongoing programmes and activities, which are outlined here. Assistance to date has concentrated on the following priorities:

- Research and development.
- Enabling framework.
- Markets.

Likewise, the activities will be carried out in three phases:

I) ***Phase 1 (2009/2011) Market preparation***

I.1) *Research and Development:*

Research and development as well as start-up of production of 1st generation Li-ion batteries and 2nd generation Li-ion batteries and double layer capacitors. Production of PHEV and BEV based on existing vehicle platforms and prototypes. Drive technologies (engines/converters) adapted to performance category, installation space, safety and reliability. R+D for electrical, electronic and mechanical vehicle components for PHEV and BEV.

I.2) *Enabling Framework:*

Research and development of new components in the infrastructure. Testing and simulation facilities for grid integration trials. First public charging stations. Studies and demonstrations for coupling with renewable energies. Safety standards. Regulatory framework. Standardisation of interfaces.

I.3) *Market Development:*

Application in fleet tests.

II) ***Phase 2 (2011 -2016) Market escalation***

II.1) *Research and Development:*

Demonstration and field tests of Li-ion batteries and double layer capacitors. Mass production of 1st generation Li-ion batteries. Production start-up of 2nd generation Li-ion batteries and double layer capacitors. R+D on 3rd + 4th generation Li-ion batteries. Production of PHEV and BEV based on existing platforms by all OEMs in small lots. Serial production maturity of 2nd generation PHEV /BEV platform. R+D for economical drive technologies and vehicle components for 2nd generation platforms.

II.2) *Enabling Framework:*

Charging infrastructure in many towns and regions. Research, development and initial trials for grid integration (load management). Coupling with renewable energies. Development of advanced charging and energy transmission systems. Use of procurement guidelines for the public sector. Appraising systems of incentives.

II.3) *Market Development:*

First private users. Business models for charging, feedback and batteries.

III) ***Phase 3 (2017 -2020) Mass market (aim: lead market in Electromobility)***

III.1) *Research and Development:*

Mass production of 2nd generation of Li-ion batteries and double layer capacitors. Production start-up of 3rd generation Li-ion batteries Continuation of R+D on Li-ion batteries and alternative storage technologies. Mass production of 2nd generation PHEV/BEV. Production of higher performance BEV/PHEV.

III.2) *Enabling Framework:*

Field tests on complete systems under realistic conditions. Full-coverage charging infrastructure. Grid integration and feedback. Initial trials of fast loading, contactless energy transfer.

III.3) *Market Development:*

One million electric vehicles on Germany's roads in 2020. Germany is the lead market for Electromobility.

2.3. Brief comparison between the two types of plans

The GFGNEDV (German Electromobility Federal Government's National Development Plan) was launched in August 2009 while the CSPEVS (Comprehensive Strategy for the Promotion of Electric Vehicles in Spain) started at the beginning of 2010.

The first major difference we found between the two plans is that both have different aims: whereas in Spain the aim is to facilitate the introduction of electric vehicles in 2014 so that there is 250000 pieces of these vehicles, in Germany they want to be leaders in Electromobility market so that in 2020 there will be a million electric cars on the roads in Germany.

The structure of the plans is also different: in Germany is structured in phases which are defined in dates in which to achieve their short-term objectives and actions in Spain to carry out are not dated.

Both plans give utmost importance to the research, development and innovation in the electric vehicle industry and aim to facilitate as far as possible the acquisition of an electric vehicle by consumers.

There are currently circulating in Germany about 1600 electric vehicles while in Spain there are only about 680.

In Spain today has 356 public charging points of which 82 are in Madrid. In Germany there are about 900 public charging points of which about 80 are in Berlin and 5 are located in Düsseldorf.

These figures are reflected in major breakthrough in Germany with respect to Spain in terms of electro-referred.

3. TECHNICAL DETAILS OF ELECTRIC CARS

3.1.Types of batteries

Lead-Acid

Flooded Lead-Acid batteries are the cheapest and most used in thermals vehicles for boot them because these types of batteries can provide high current levels in short periods of time. However because of their poor autonomy, short life and their long period of load (between 10 and 16 hours), the utility in electric vehicles is limited to auxiliary systems as radio, lights... These batteries also require inspection of electrolyte level and replacement of water.

The advantages of Lead-Acid batteries are their mature technology, high availability and low cost.

Like all batteries, they have significantly lower energy density than petroleum fuels, in this case 30-40Wh/kg. The efficiency is between 70-80% and the power around 180 W/kg. These types of batteries can work 500 cycles of load and can support overloads. The average value in each cell voltage is 2V and the appropriate range of temperatures is between -20°C and 60°C. The monthly self-discharge rate is 5%.

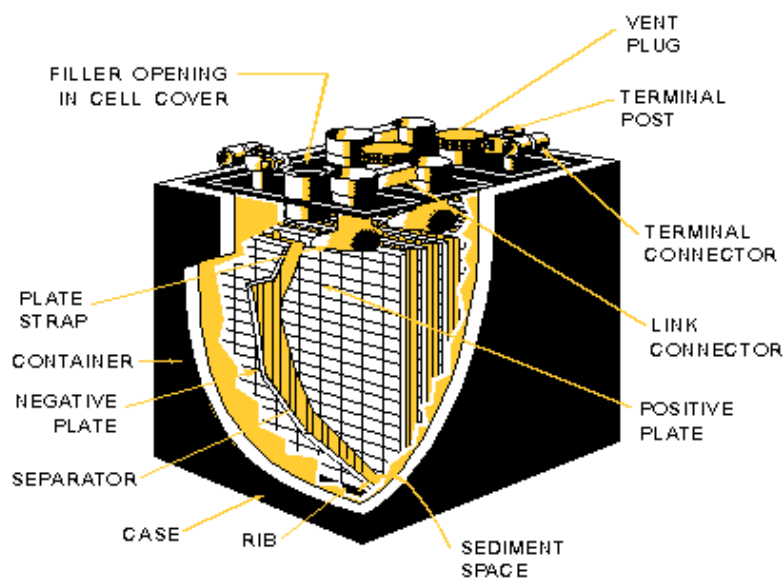
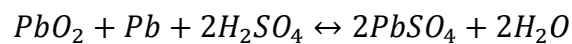
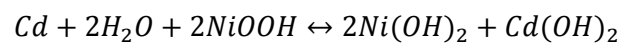

Figure 3: "Lead-acid battery construction" Source: Tpub

Nickel-Cadmium (NiCd)

The endurance of the Nickel-Cadmium batteries is higher respect the Lead-Acid batteries, but a European rule limited her used for been the Cadmium a heavy metal with problems for the environment.

The reaction that takes place inside the battery is as follow:



One advantage of this kind of battery is that it can provide high current level with reduced voltage. On the other hand these batteries have memory effect, this means if the battery is recharged before losing the entire charged, for example when the battery is at 50% of its capacity, will appear Cadmium crystals causing the next time that it will be recharged it will assume that the new level 0 of charged is that was 50%.

Its energy density is 60 Wh/kg and 50-150 Wh/liter. They have a moderate overload tolerance and the range of temperatures for their correct operation is between -40°C and 60°C. The average voltage in each cell is 1,25 V and the monthly self-discharge rate is 20%.

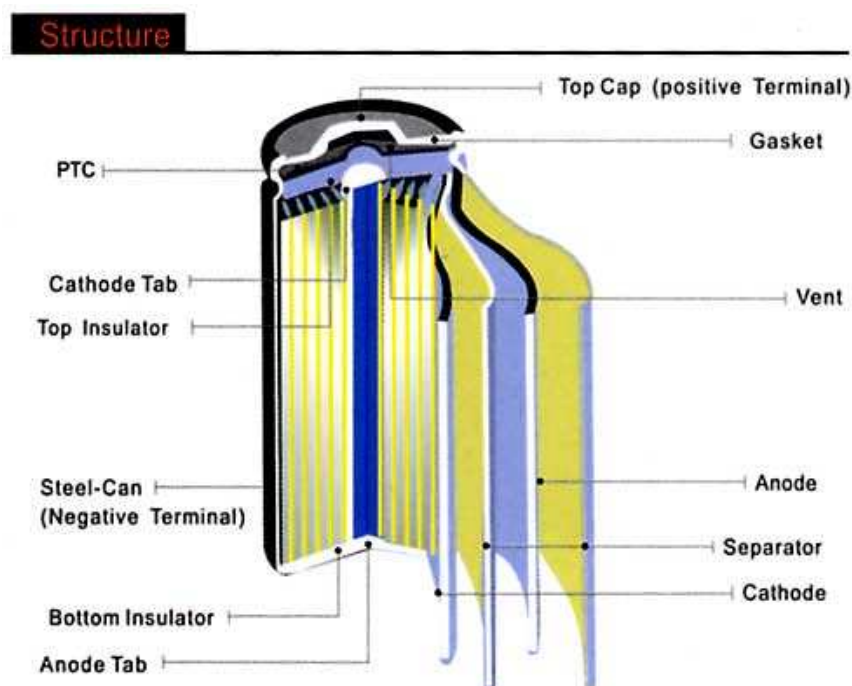

Figure 4: "Nickel-cadmium battery"

Nickel metal hydride (NiMH)

Nickel-metal hydride batteries are now considered a relatively mature technology. While less efficient (60-70%) in charging and discharging than even lead-acid, they boast an energy density of 70Wh/kg and 143-300 Wh/liter, far higher than lead-acid.

When are used properly, nickel-metal hydride batteries can have exceptionally long lives (approximately 1000 recharge cycles, ten times longer than the Nickel-Cadmium batteries), as has been demonstrated in their use in hybrid cars like the Toyota Prius or RAV4EV that still operate well after 100,000 miles (160,000 km) and over a decade of service. Another is that with this technology the problem of memory effect due to Cadmium, disappear.

Downsides include the poor efficiency, high self-discharge (30% per month), very finicky charge cycles, poor performance in cold weather and the low resistance to overload. These batteries also are more expensive than the previous and the average voltage in each cell is low (1,25V). GM Ovonic produced the NiMH battery used in the second generation EV-1, and Cobasys makes a nearly identical battery (ten 1.2V 85Ah NiMH cells in series in contrast with eleven cells for Ovonic battery). This worked very well in the EV-1.



Figure 5: “Toyota hybrid car equipped with NiMH”

Source: Powerpulse

Lithium –Ion

Lithium-ion batteries, widely known through their use in laptops and consumer electronics, dominate the most recent group of EVs in development. The traditional lithium-ion chemistry involves a lithium cobalt oxide cathode and a graphite anode. The energy density is one of the advantages of this type of batteries that is around 200 Wh/kg as well as 80 to 90% charge/discharge efficiency and high autonomy. They are also recyclable and haven't memory effect in addition to a low weight and a low monthly self-discharge (10%).

The downsides of traditional lithium-ion batteries include a not very long life (hundreds or thousands charge cycles) and significant degradation with age. The cathode is somewhat toxic. Also, traditional lithium-ion batteries can pose a fire safety risk if punctured or charged improperly. Nowadays the maturity of this technology is improving so much.

But the most important problem of these batteries is the poor resources of lithium.

According to a study by William Tahil, the director of Research of Meridian International, if all thermal vehicles (900 millions) were replace for electrical vehicles equipped with ion-lithium batteries of 20 kWh, would be necessary to spend the 50% of the current resources of lithium. For this and because of would be necessary 75 years for building all of those batteries, currently the industry is focusing on development of battery technologies more viable like Zebra or Zinc-Air batteries.

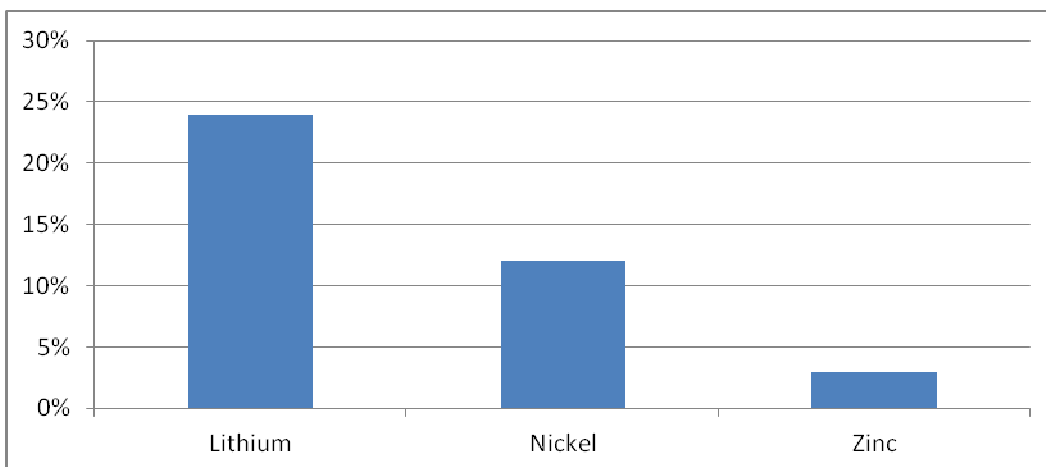

Figure 6: “Percentage of resources metal allocated to electrify 900 million vehicles equipped with 10kWh batteries” Source: Meridian International Research

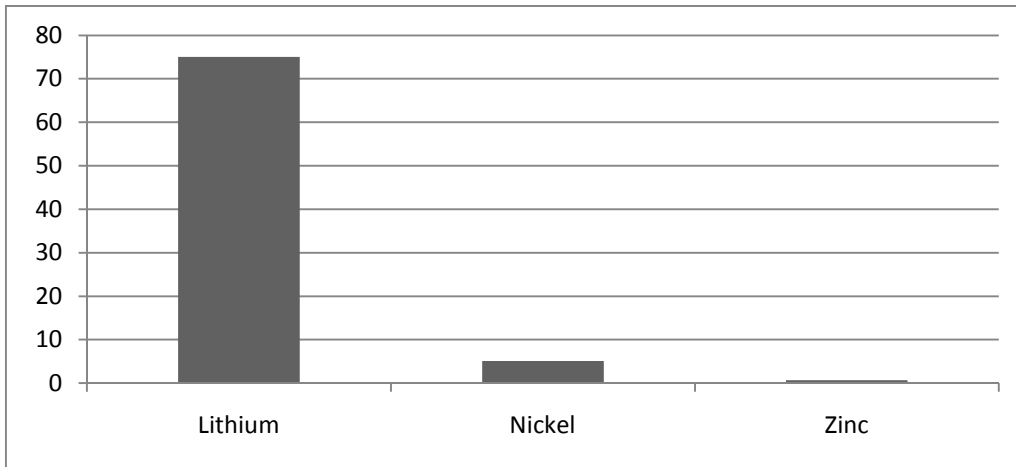

Figure 7: “Years needed to make batteries for 900 million vehicles”

Source: Meridian International Research

The Tesla Roadster uses "blades" of traditional lithium-ion "laptop battery" cells that can be replaced individually as needed.

Most other EVs are utilizing new variations on lithium-ion chemistry that sacrifice energy density to provide extreme power density, fire resistance, environmental friendliness, very rapid charges (as low as a few minutes), and very long lifespans. These variants (phosphates, titanates, spinels, etc.) have been shown to have a much longer lifetime, with A123 expecting their lithium iron phosphate batteries to last for at least 10 years and 7000 charge cycles, and LG Chem expecting their lithium manganese spinel batteries to last up to 40 years.

Much work is being done on lithium ion batteries in the lab. Lithium vanadium oxide has already made its way into the Subaru prototype G4e, doubling energy density. Silicon nanowires, silicon nanoparticles, and tin nanoparticles promise several times the energy density in the anode, while composite and superlattice cathodes also promise significant density improvements.

In 2009 Mitsubishi (i-MiEV) and Subaru (Stella) introduced electric vehicles offered for fleet then public sale.

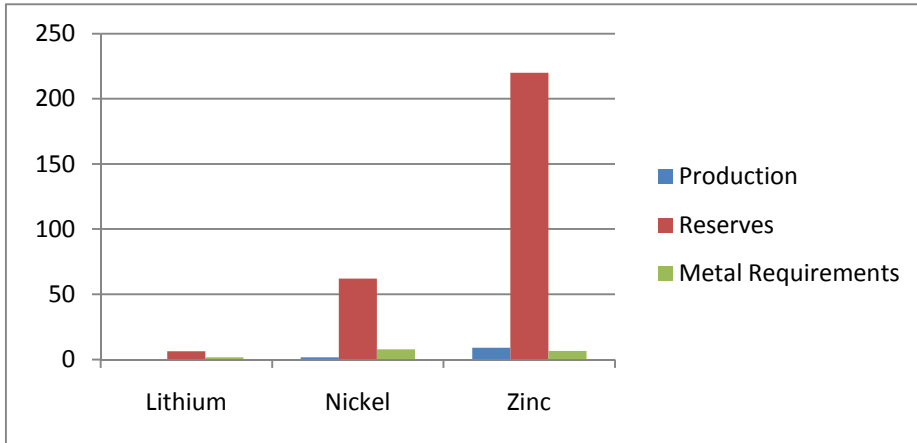

Figure 8: Comparison of production, reserves and metal requirements in million tons for electrify 900 million vehicles with 10 kWh battery

Lithium Polymer

These kind of batteries are characterized for have a plastic electrolyte so they don't need metallic coating and they can take many forms as well as they are safer than ion-lithium ones.

Although they can provide good energy density (200 Wh/kg) and also a high power (3000W/kg), they are just used in some devices types very thin because their features are similar or worse than the ion-lithium batteries.

Zebra

The sodium or "zebra" battery uses a molten of chloroaluminate (NaAlCl_4) sodium as the electrolyte. This chemistry is also occasionally referred to as "hot salt". This relatively mature technology, hasn't a high energy density, this is around of 120Wh/kg. They must be heated for use because these batteries operate at a high temperature range (270°C-350°C), but cold weather doesn't strongly affect for the operation except for increasing heating costs and spending much energy. Their performance is very high near of 100% and they have a long life besides can support short circuits very well. The nominal capacity is 38 Ah and 20 kWh.

They have been used in several EVs, for example in the Modec vehicle since it entered production in 2006, or the Think City which is equipped with Zebra batteries of 28,3 kWh.

The only company that manufactures this type of batteries is Mes-Dea from Switzerland.



Figure 9: "Zebra Battery" Source: Vehiculos verdes

Zinc-Air

According to investigations, the future of Electromobility is linked to Zinc-Air batteries for their high energy density (370Wh/kg, 3 times higher than lithium), their long life because they can be recharged and recycled as many times as you want, and also for the low cost of this kind of technology. Others advantages are the low weight, high safety and zero CO₂ emissions.

Unlike the situation with lithium, there are available resources of Zinc for produce billions of these batteries as mentioned in White Book of Meridian International Research, that also says world production of zinc in 21 months would be sufficient to produce a billion of electric vehicles equipped with 10 kWh batteries zinc-air, while it would take 180 years to produce enough lithium for the same number of batteries.

The downside is for recharge these batteries you have to extract the Zinc from inside of the battery, for being recharged outside. But this isn't a big problem because this process can be quickly made in a station service, replacing the old Zinc for another one new or recycled.

Nowadays these batteries are used for hearing aids and portable electronic systems, but all researching talk about Zinc like the electric fuel future.

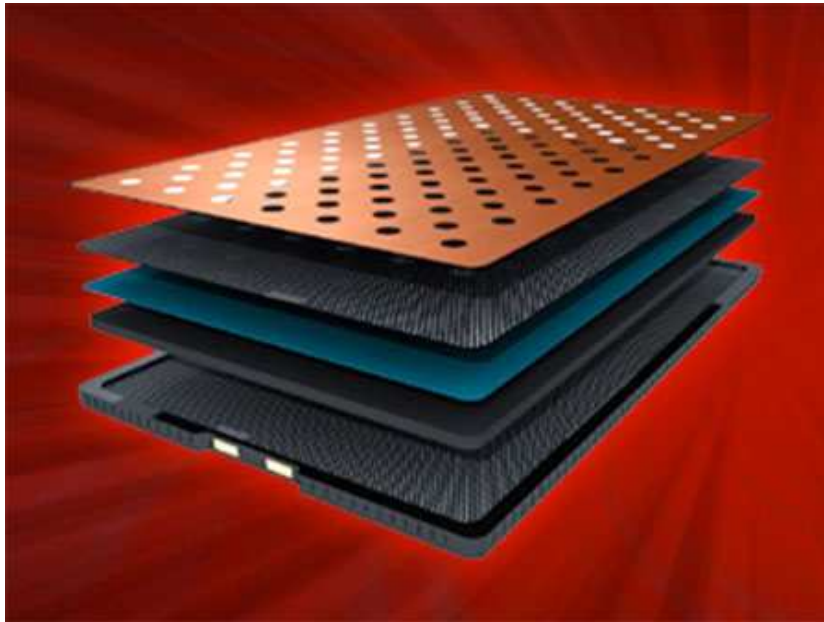

Figure 10: “Zinc-Air batterie” Source: Treehuger

As abstract of all type of batteries we will see the next table comparing the characteristics of each:

| Type of battery | Energy (Wh/kg) | Energy/Volume (Wh/liter) | Power/Weight (W/kg) | Life (Cycles) | Energy efficiency % |
|------------------------|----------------|--------------------------|---------------------|---------------|---------------------|
| Lead-Acid | 30-40 | 60-75 | 180 | 500 | 70-80 |
| Nickel-Cadmium | 60 | 60-150 | 180 | 500 | 82 |
| NiMH | 70 | 143-300 | 250 | 1000 | 60-70 |
| Li-ion | 200 | 270 | 1800 | 1000 | 80-90 |
| Lithium Polymer | 200 | 300 | 3000 | 1000 | 90 |
| Zebra | 120 | 300 | nd | 1000 | 99 |
| Zinc-Air | 370 | 750 | nd | 1000 | 99 |

Figure 11: "Comparative table"

According with Meridian International Research the cost to manufacture a battery of 30 kWh with the differences view technologies is:

$$\text{Li-ion: } 30 \text{ kWh} \cdot 240 \frac{\text{€}}{\text{kWh}} = 7200\text{€}$$

$$\text{Zebra: } 30 \text{ kWh} \cdot 100 \frac{\text{€}}{\text{kWh}} = 3000\text{€}$$

$$\text{Zinc-Air: } 30 \text{ kWh} \cdot 70 \frac{\text{€}}{\text{kWh}} = 2100\text{€}$$

3.2. Constructive Aspects

In this chapter we will try to give an overview of the different possible configuration that make possible the transition from thermal cars to pure electric cars, through hybrids.

We will see the most important characteristics of these available configurations which are Hybrid, Plug-in Hybrid and Pure Electric.

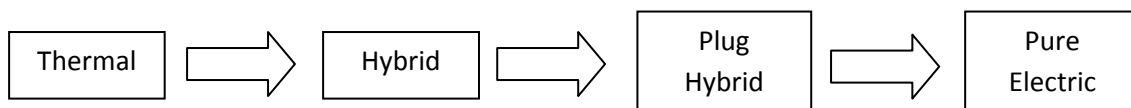

Hybrid Electric Vehicle (HEVs)

This kind of car has two engines, the thermal one and the electric one, and there are three different configurations for propel the car. In all the cases the car cannot be plugged to the net, and the batteries for feed the electric engine are recharged by the thermal engine which move a generator and also by the regenerative braking. So these cars don't have the problem of autonomy like the pure electric cars, they are more efficient and their price is not much higher than the thermal cars. This is the first step to the pure electric cars.

The most usual configuration is both engines can traction the wheels (**parallel connection**). The electric engine works alone below 30 km/h so the noise is zero and also CO2 emissions.

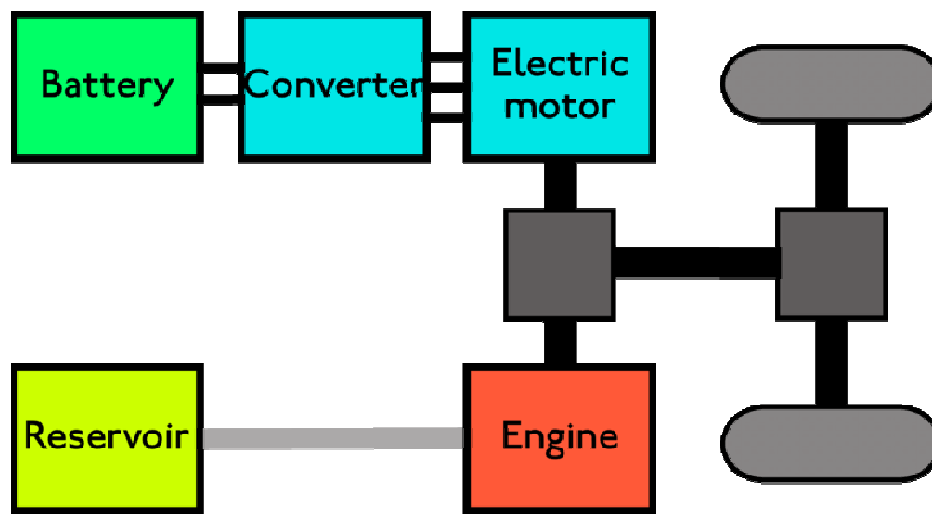

Figure 12: "Parallel configuration scheme"

Source: Sport car buzz

The batteries must have more capacity than the batteries from the cars equipped with conventional combustion engine and the auxiliary systems like air conditioning or power steering are fed from the electric engine for improve the car performance because these systems can work to constant speed regardless the speed that you are driving.

Nowadays the most commercial car of this technology is the Toyota Prius. It has NiMH batteries of 28 modules with a consumption of 6,5 Ah and a nominal voltage of 201,6V. Include its low consumption and low CO2 emissions.



Figure 13: "Toyota Prius" Source: Motor pasion

The thermal engine always operates at peak efficiency and whether it generates more energy than necessary electric motor acts as generator to charge batteries.

Another technological advancement is being introduced even in vehicles with internal combustion engine is called Start-Stop, which is responsible for turning off the engine when you make a stop (traffic lights, pedestrian crossing) for reduce CO2 emissions.

Serial Connection: The internal combustion engine does not directly move the wheels, only used to generate electricity. Thermal Engine operates at an optimal capacity and recharges the battery until it is fully filled. The wheels are powered completely by electric energy from the battery. The thermal engine is turned on again when the battery is nearly depleted. E-REV is another name for series hybrid car, also defined as an electric (not hybrid) car that uses a gasoline engine as internal recharger.

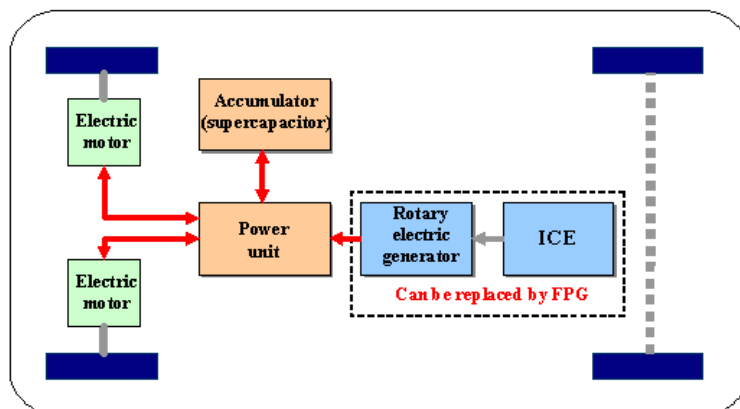

Figure 14: “Serial configuration scheme” Source: Reviewcar

As the combustion engine is not connected to the vehicle's transmission, it can rotate at a constant speed, so its performance is quite close to theoretical, about 37%.

Energy produced by the combustion engine must flow through the generator, batteries and electric motor, which reduces performance. In long distances mostly of the energy is provided by the internal combustion engine as its yield is reduced compared to the parallel model.

For reduce the losses on items such as transmissions and differentials, the option is put an electric motor on each wheel.

Combined Hybrid: Hybrid car that uses both series and parallel configuration. Series hybrid is more efficient in low speed and parallel hybrid at high speed.

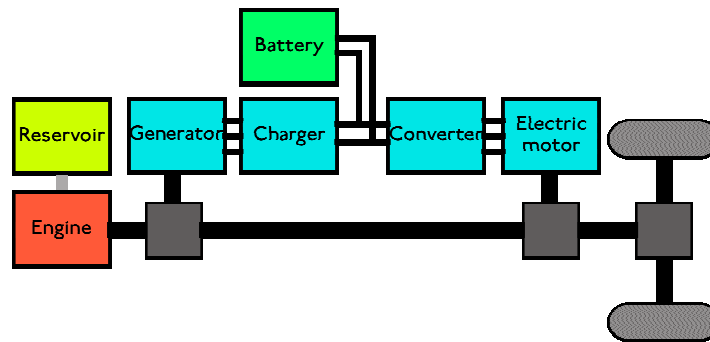

Figure 15: “Combined Hybrid” Source: Reviewcar

Plug-in Hybrid Electric Vehicle (PHEVs)

The PHEV is postulated as the precursor to pure electric vehicles. It offers all the benefits of HEVs because it has a combustion engine and an electric engine but it can be connected to the network for recharge the batteries.

This kind of vehicles also solves the problem exists today because of poor infrastructure to recharge the batteries through the network because if you cannot connect the vehicles to the net it can be recharged through the combustion engine.

As in the case of HEV, PHEV has two different configurations. Parallel configuration that both engines can give traction to the wheels, and serial connection that the combustion engine can only provide energy to the electric engine.

Nowadays the vehicles that are available are Toyota Prius Plug-in and the Chevrolet Volt which has autonomy of 64 km using just the electric engine. This distance is higher than the average distance traveled by the majority of the population, so throughout the year most of the miles would be made with the electric engine and thermal engine is only used to recharge the batteries on long trips.

The recharges should be done at night when the demand is lowest and the price of the energy is also lowest and this could facilitate the integration of renewable energies like wind energy which their generation is higher during the night.

According to studies by General Motors, if you drive the Chevrolet Volt with the batteries energy you will spend two cents per kilometer compared with the eight cents that you will spend driving a car equipped with thermal engine. Driving average distance of 22.000 km per year, the difference on the price would be 2.200 euros (per year) between use a conventional car or use an electric car.

Most of these cars are equipped with Li-ion batteries. As mentioned above, these batteries present a risk of overheating and explosion so the investigations focus on other technologies based on Zinc or NaCl.



Figure 16: “Toyota Prius Plug In” Source: Coches eco

Pure Electric (EVs)

As stated above, the Electromobility has many advantages but it still has some barriers to break down as the development of batteries and the infrastructure to recharge them.

As we said previously, projects like the Movele Project from Spain focus on the development of recharge points in public and private places and also on the development of recharge stations where users of electric cars can replace in a few minutes the empty battery for another recharged (Project Better Place). These last projects are been developed specially in Israel and Denmark due to their small size.

The electrification of transport is also important for producers of current vehicles, because they can stay in business due to this new concept of mobility.

Because of the limited current infrastructure of charging points, presents works focuses on vehicles designed for short trips within the city with sufficient autonomy to cover the distance average daily users. This will reduce local CO2 emissions and noise level in urban areas.

Electric cars have fewer mechanical parts than combustion cars, because these haven't clutch, gearbox so the maintenance will lower too.

These vehicles can be equipped with one or more electric motor. The single engine configuration is more suitable for big vehicles that need more power. On the other hand, the arrangement of some engines placed in each wheel is more appropriate for small vehicles eliminating transmission losses.

Therefore is necessary to develop batteries for are able to provide more autonomy, as well as reduce the price of these. For reduce its price, the Movele Project from Spain proposes that the customer buys the car without batteries, and then pay a monthly fee to have the battery recharged at any point of recharge. The client will be paying a fee for a service including batteries, electricity and infrastructure available, so the initial cost of the electric car does not differ much with a patrol car. But also is necessary to expand the recharge infrastructure points and the efficiency of these for recharge the batteries quickly.

At low speeds, electric cars produced less roadway noise as compared to vehicles propelled by an internal combustion engine. Blind people or the visually impaired consider the noise of combustion engines a helpful aid while crossing streets, hence electric cars and hybrids could pose an unexpected hazard. Tests have shown that this is a valid concern, as vehicles operating in electric mode can be particularly hard to hear below 20 mph (30 km/h) for all types of road users and not only the visually impaired. At higher speeds the sound created by tire friction and the air displaced by the vehicle start to make sufficient audible noise.

The US Congress, the European Commission and the Government of Japan are exploring legislation to establish a minimum level of sound for hybrids and plug-in electric vehicles when operating in electric mode, so that blind people and other pedestrians and cyclists can hear them coming and detect from which direction they are approaching. The Nissan Leaf is the first electric car to include Nissan's Vehicle Sound for Pedestrians system, which will include one sound for forward motion and another for reverse.

Available electric cars Nowadays

| Model | Top speed | Acceleration | Capacity Adults+kids | Charging time | Nominal range | Market release date |
|-----------------------------|--------------------|-------------------------------------|----------------------|---|-----------------|---------------------|
| Wheego Whip LiFe | 105 km/h (65 mph) | | 2 | | 161 km (100 mi) | Dec 2010 |
| CODA Sedan | 129 km/h (80 mph) | 0–60 mi/h in 11 seconds | 4 | full charge in approx. 6 hours | 193 km (120 mi) | Q3 2011 |
| REVA NXR | 104 km/h (65 mph) | | 4 | | 160 km (99 mi) | 2011 |
| Renault Fluence Z.E. | 135 km/h (84 mph) | 0-62 mph: 9.0 seconds (est) | 5 | 6–8 hours with standard AC power; 30 minute rapid charge to 80% | 161 km (100 mi) | Early 2011 |
| Tata Indica Vista EV | 105 km/h (65 mph) | 0-62 mph: 10.0 seconds (est) | 4 | | 241 km (150 mi) | Q1 2011 |
| Ford Focus Electric | 137 km/h (85 mph) | | 5 | approx 6 to 8 hours, 230 V/16A | 160 km (99 mi) | Late 2011 |
| Hyundai BlueOn | 130 km/h (81 mph) | 0–100 km/h in 13.1 | 4 | 6 hours with 220 V power; 25 minute rapid charge to 80% | 140 km (87 mi) | Late 2012 |
| Tesla Model S | 193 km/h (120 mph) | 0 to 97 km/h (0 to 60 mph) in 5.6 s | 5+2 | Full charge 3.5 hours using the High Power Connector or 45 minute QuickCharge | 483 km (300 mi) | 2012 |

Figure 17: “Table of some cars available nowadays”

4. COMPARISON OF THE MEDIUM/LOW VOLTAGE NETWORKSTRUCTURE OF DÜSSELDORF AND MADRID

4.1. Medium/Low Voltage Network Structure of Madrid

Madrid is the capital and largest city of Spain. The population of the city is roughly 3.3 million (as of December 2009); the entire population of the metropolitan area (urban area and suburbs) is calculated to be nearly 6.5 million. Iberdrola provides power to approximately 4.200.000 inhabitants in Madrid, according to data provided by the company itself so that it will be the number we take into account in our study. The city is located on the river Manzanares in the centre of both the country and the Community of Madrid.

Firstly, we are going to proceed to describe how energy is distributed in the present case.

We can see how energy is generated in hydraulic power, nuclear power stations, conventional thermal powerplants and renewables such as wind, photovoltaic, solar, etc.

The energy obtained is transformed to very high voltage, 400 kV (to minimize energy loss) for transport. Red Eléctrica de España is the manager of the transmission grid and acts as the sole transmissioner on an exclusive basis.

As we can see in the following picture, when energy gets into the transformer substation, it goes from having a value of 220 kV to another between 66 and 45 kV (being previously transformed from 400 kV into 220 kV) so we are in high voltage area.

This energy is transported through the distribution lines to reach the substation distribution transformer. There becomes medium voltage, 20 kV and 15 kV.

Finally, low voltage conversion occurs in the processing centers where we get the 400-230 V to supplied in urban area.

We can see and fully understand the whole process in the following figure:

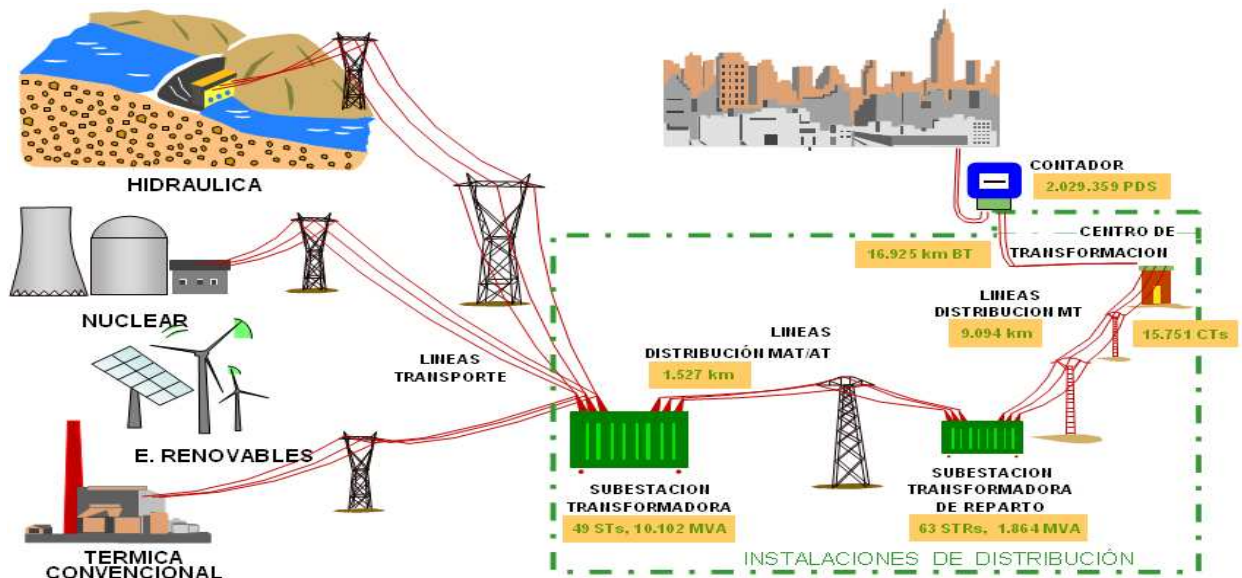
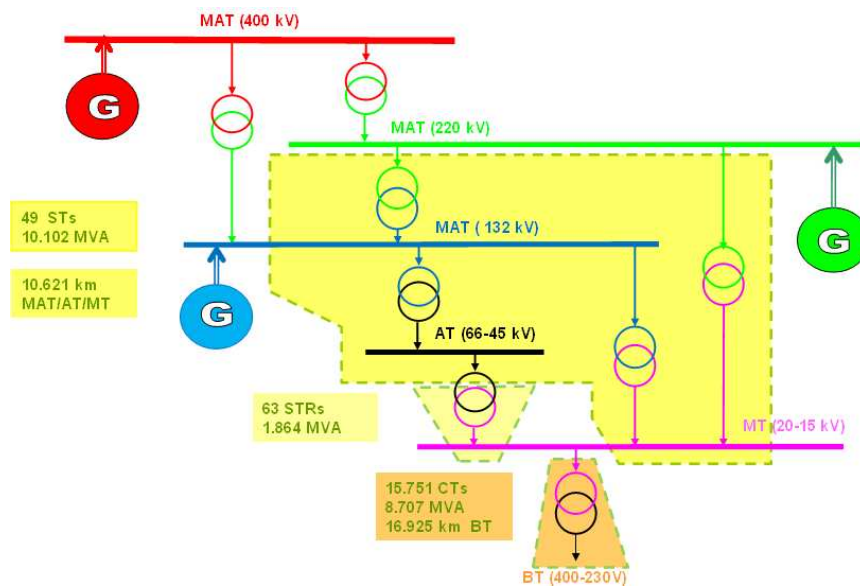

Figure 18: "Electricity path Madrid" Source: Iberdrola Distribution

In that picture, also we can see the length of the lines, the power in MVA and how many centers there are of each type.

Below we see a line diagram of the network in Madrid:



MAT=Very High Voltage AT=High Voltage MT=Medium Voltage BT=Low Voltage

Figure 19: "Network in Madrid" Source: Iberdrola Distribution

There are 49 transformer substations with an installed processing capacity of 10102 MVA in total (about 206 MVA per substation).

The total length of very high voltage lines, high voltage lines and medium voltage lines is 10621 km.

The length of the lines of 132 kV, 66 kV, 45 kV (very high voltage and high voltage) is 1527 km so that the remaining 9094 km are medium voltage lines of 15kV and 20 kV.

In medium voltage, we can find 112 substations with an installed processing capacity of 6193 MVA in total.

There are 63 distribution transformer substations with an installed processing capacity of 1864 MVA in total (about 30 MVA per substation).

Finally, there are 15751 processing centers with an installed processing capacity of 8707 MVA in total and the total length of low voltage lines is 16925 km.

5212 of these Distribution and Processing Centers are particular.

Below are the types of transformers used for each voltage:

VERY HIGH VOLTAGE INTO HIGH VOLTAGE:

These transformers convert 400 kV to 220 kV. They are property of Red Eléctrica de España. It consists of two transformers of 450 MVA each.

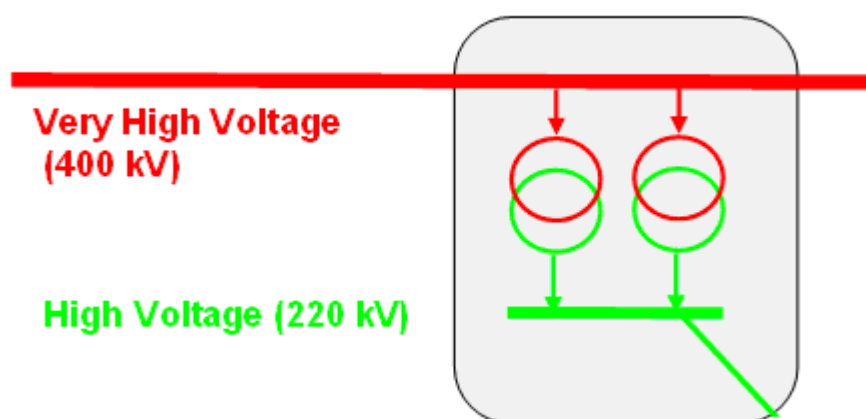

Figure 20: “VHV/HV TRANSFORMER” Source: Iberdrola Distribution

HIGH VOLTAGE INTO MEDIUM VOLTAGE:

These transformers convert 220 kV to 20 kV. There are three transformers of 50 MVA each so the configuration is as follow:

-For 220 kV the system is GIS (encapsulated) double bar which tend to have three lines of 220 kV.

-For 20 kV the system is GIS (encapsulated) double bar with 3X10 outputs. There is also a longitudinal coupling between bars of 20 kV.

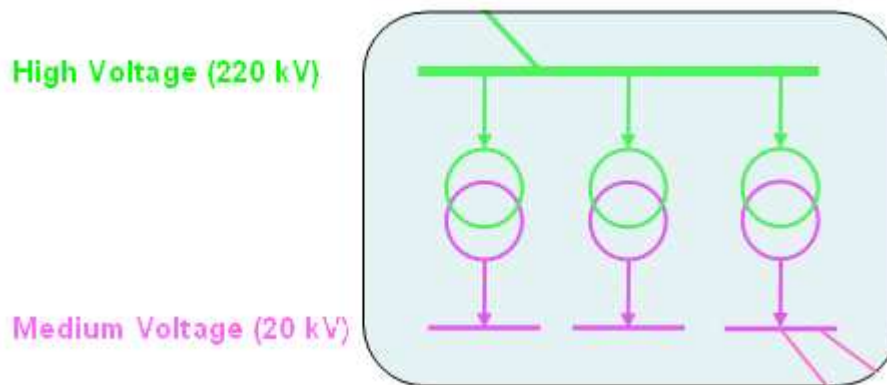

Figure 21: “HV/MV TRANSFORMER” Source: Iberdrola Distribution

MEDIUM VOLTAGE INTO LOW VOLTAGE:

These transformers convert 20 kV to 0,4 kV. In a typical transformation Center we have two transformers of 630 KVA of power each. They have two line breakers and two fuses for transformers and two low voltage boxes, with three or five outputs each.

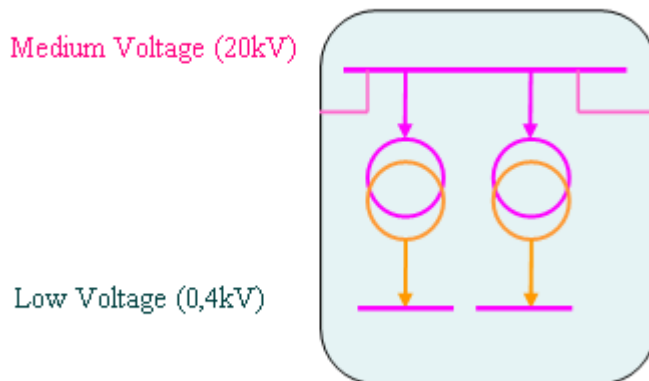

Figure 22: “MV/LV TRANSFORMER” Source: Iberdrola Distribution

In urban networks tend to avoid intermediate transformations between transport (220 kV) and medium voltage (15 or 20 kV).

In Madrid city substation typical configuration are as follow:

ST 132/15 kV with three transformers of 40 MVA 132/15 kV

ST 220/15 kV with three transformers of 50 MVA 220/15 kV

Although in Iberdrola the preference voltage for the MV network is 20 KV, there are some areas with others voltage levels like Madrid city where is supplied with 15 KV.

In Madrid is so common the “Distribution Center” which is a switching Center that provides protections in its outletstand, usually feeds 2 or 3 large section cables (AL400) from the station. It allows reducing outputs number of the Substations and also this way downstream failures don’t affect the entire substation feeder.

In MV the most used cables for urban areas are AL240 for distribution and AL400 for connecting the Substation to Distribution Centers.

The MV network has a big number of interconnections, which allows a very important support power between substations. The tendency is to support even the complete failure of a substation with the help of support from other substations. In older networks the design of the MT network doesn’t follow a clear structure.

In modern networks (urban and rural) the trend of the loads is based on two complementary systems:

- From the substation feeding Distribution Centers located near major consumption areas, from these Distribution Centers out cables that connect with the Transformation Centers and finish in another Distribution Center (or Substation)
- Loads closer to the substation are feeded directly from the substation with distribution cables which finish in another substation or other Distribution Center.

The low voltage that coming out of each TC run through the streets connecting the points of low voltage supply in so-called CGPs (Box General Protection), which basically allow the referral to the client is protected by a fuse. In Spain they are the property line between the distributor and low voltage supplies.

Now we are going to see some examples with photos.

The following picture shows a typical Medium Voltage Network in the center of Madrid:

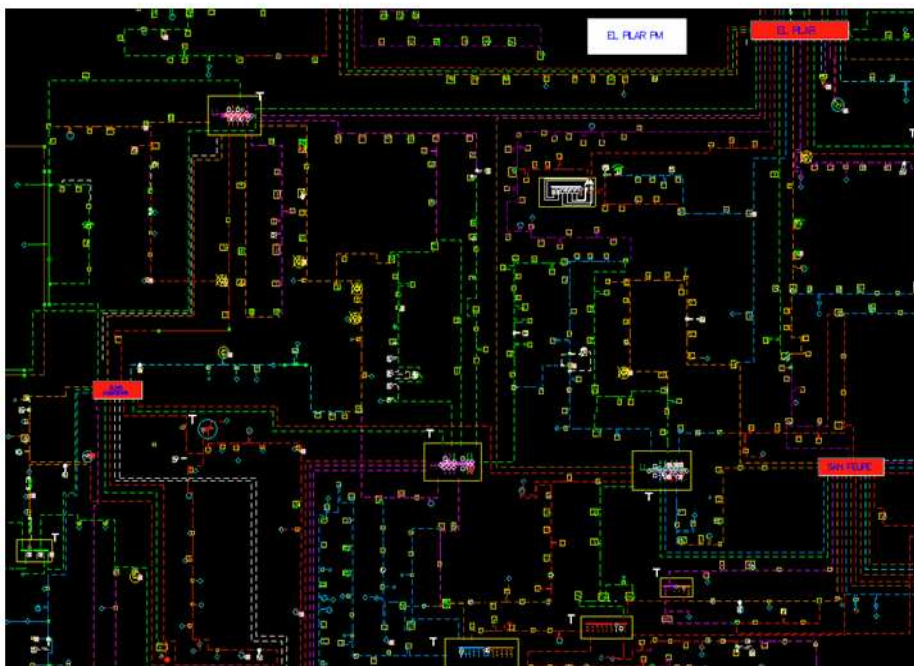

Figure 23: “Medium Voltage Network” Source: Iberdrola Distribution

Now, an example of a Low Voltage Network:



Figure 24: “Low voltage Network” Source: Iberdrola Distribution

Finally, the last picture shows the interior of two processing centers, namely CT Crial and CT Comandante Fortea:



Figure 25: “Processing Centers” Source: Iberdrola Distribution

4.2. Medium/Low Voltage Network Structure of Düsseldorf

Düsseldorf is the capital city of the German state of North Rhine-Westphalia and centre of the Rhine-Ruhr metropolitan region. The population of the city is nearly 586200. Düsseldorf is in the middle of the lower Rhine basin, on the delta of the Düssel River where it flows into the Rhine.

Energy landscape in Düsseldorf roughly as follows:

About 20% of the energy of the city is imported from the company RWE in Essen, such transport is carried at very high voltage, 400 kV.

The remaining 80% is generated in Düsseldorf, where substations are approximately 3800 and 2700 which belong to Stadtwerke Düsseldorf. Add that they are able to cover 90% of demand in the city.

Within the city there is a conventional gas turbine that works with a generator and has a capacity of 90 MW (Heizkraftwerk Flingern, it was the first big power plant in Düsseldorf). The more powerful central is Lausward Power Station which has three generators and a power of 580 MW. Lausward cogeneration plant is a combined cycle power plant (CCPP), and since 1957 the largest power plant in North Rhine-Westphalia's capital Düsseldorf. It is located in the port of Düsseldorf and its tall chimneys are visible from far away.

This power station was originally a hard coal power station. Since 1998 the gradual conversion of the power station to natural gas followed. The power station produced also long-distance heating.

Schematically, the distribution of energy in Düsseldorf would be as follows:

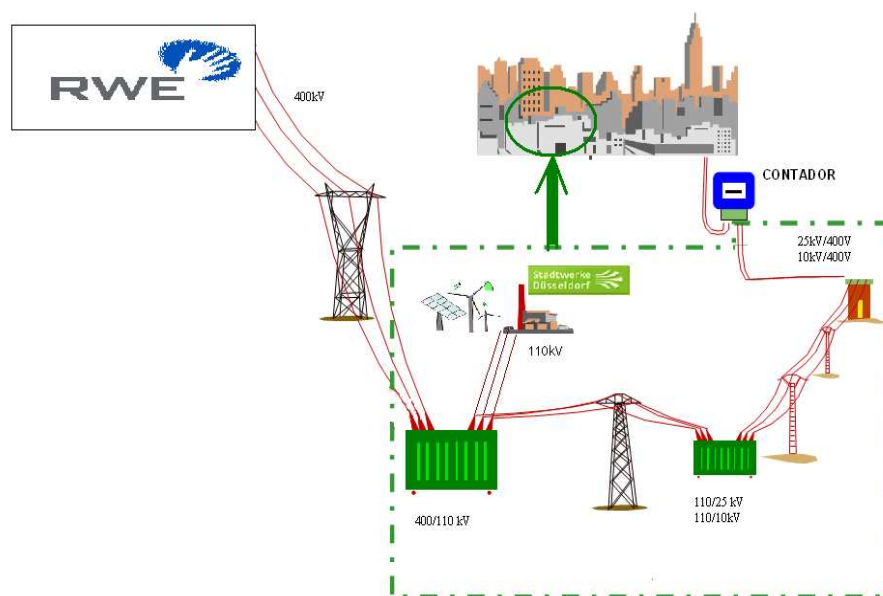
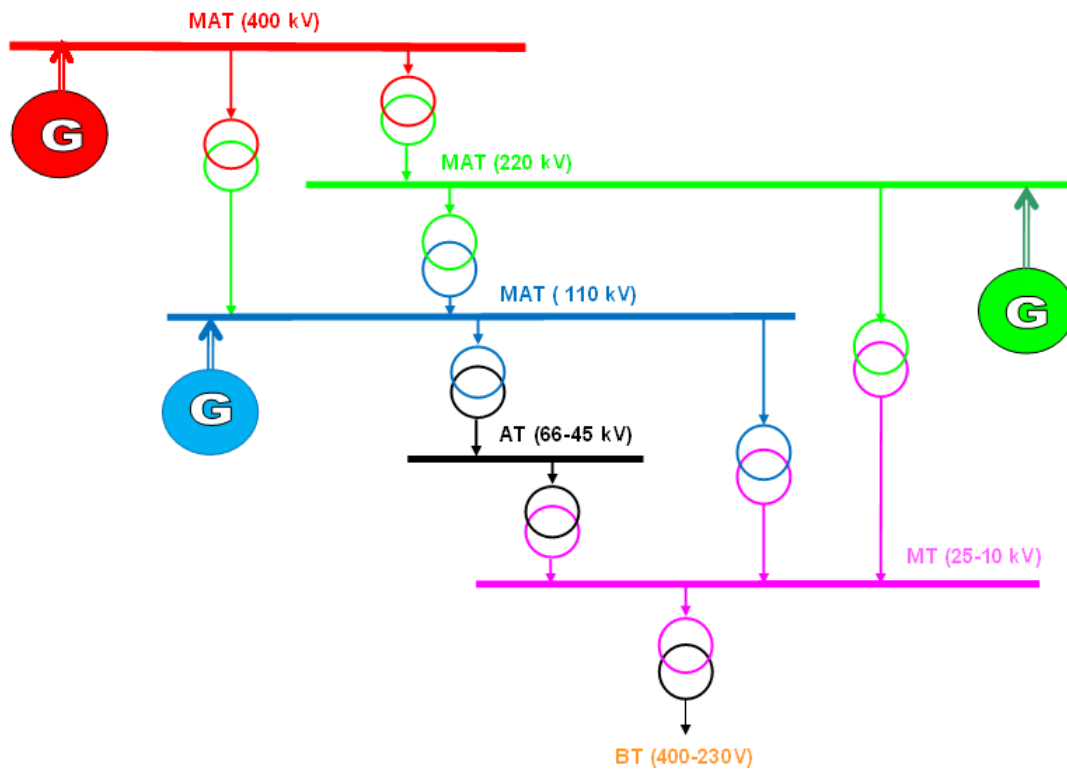

Figure 26: "Electricity path Düsseldorf"

Below we see a line diagram of the network in Düsseldorf:



MAT=Very High Voltage AT=High Voltage MT=Medium Voltage BT=Low Voltage

Figure 27: "Network in Düsseldorf"

The data discussed below date from 2009 and are the lengths of the lines. The source of information has been Stadtwerke Düsseldorf:

The length of the network without connections (System) is 9819 km.

High voltage network (110 kV) is 130 km long.

Medium voltage network (10 to 25 kV) is 3383 km long.

Low voltage network (0.4 kV) is 3462 km long.

Also, there are 89623 house connections, 46116 street lighting units and 433701 counters.

2700 stations belong to Stadtwerke Düsseldorf and transformers are about 2800 so, in most substations there is only one transformer. 1500 transformers have power of 630 kVA and the rest are rated at 500 kVA. The remaining stations (1100) are owned by the customers themselves.

Now we are going to see some examples of the Düsseldorf network structure with pictures.

The first image shows an example of very high voltage network that goes from 400 kV to 110 kV:

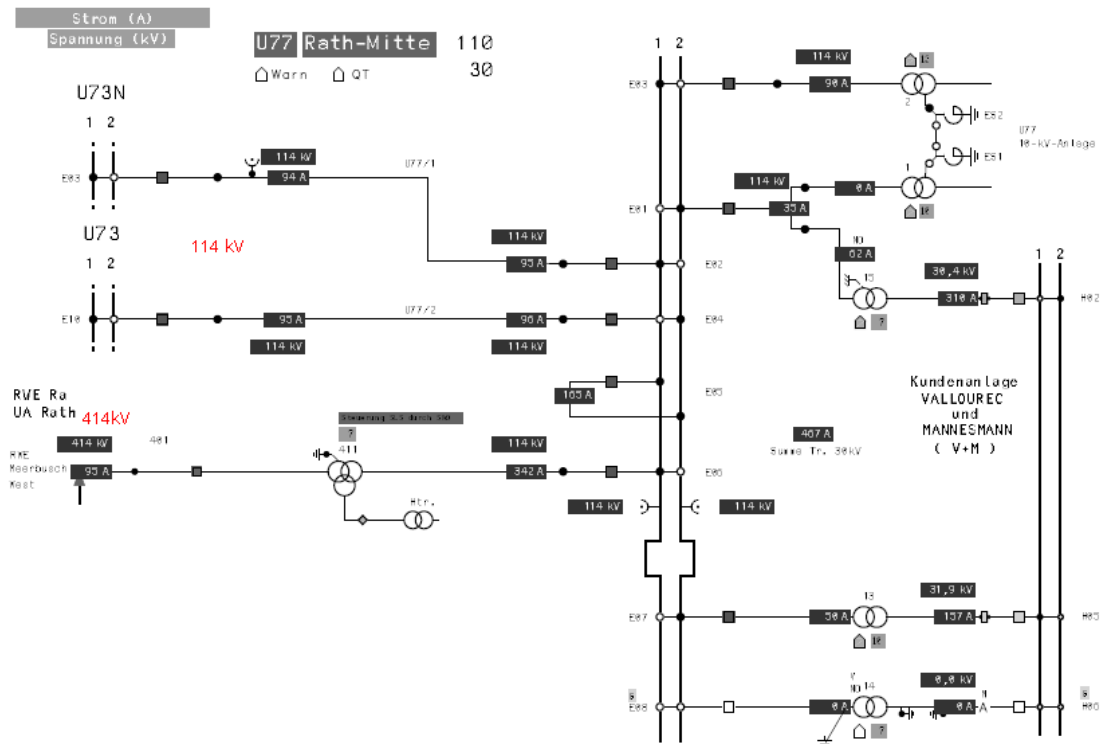

Figure 28: "VH Network Düsseldorf"

Source: Stadtwerke Düsseldorf

The second image shows an example of the network when takes place the conversion of 220 kV to 110 kV

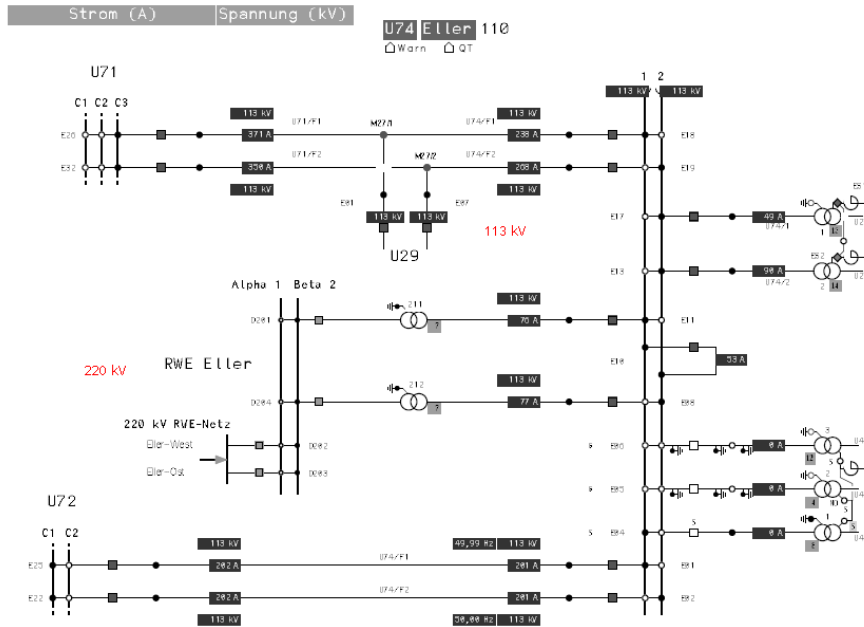

Figure 29: "220kV/110kV Network" Source: Stadtwerke Düsseldorf

Now we can see an example of the 10000 volts grid in the following picture:

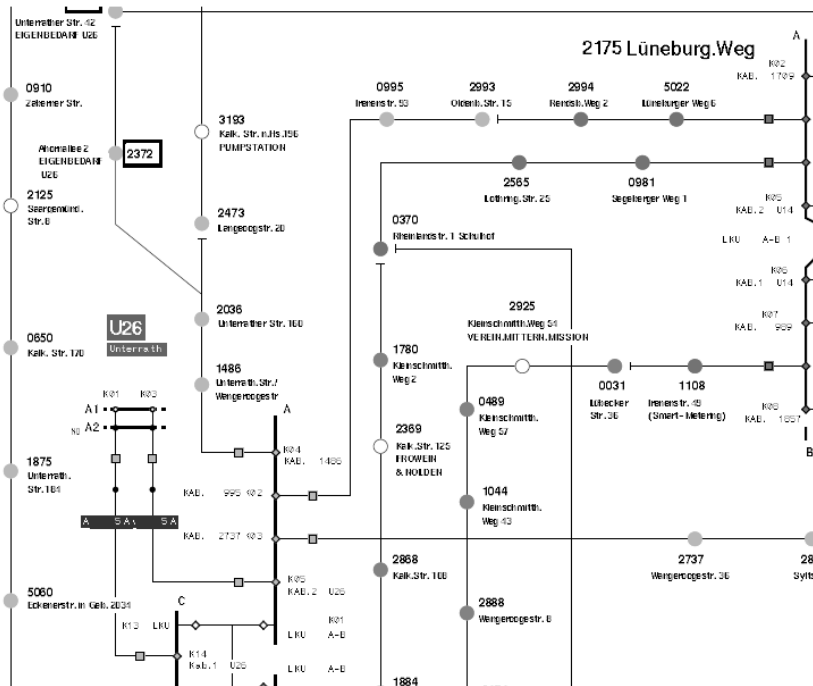

Figure 30: "10kV Grid" Source: Stadtwerke Düsseldorf

Now let's get into the inside of a typical transformer station.

Firstly we can see the low voltage part with a voltage of 400V:



Figure 31: "Substation Low Voltage part" Source: Stadtwerke Düsseldorf

It is interesting also the medium voltage part (10000 volts), this figure shows the location of the switches:



Figure 32: "Substation Medium Voltage part" Source: Stadtwerke Düsseldorf

Finally we see the picture of the transformer which produces the decrease in tension of 10 kV to 400 V:



Figure 33: “MV/LV TRANSFORMER”

Source: Stadtwerke Düsseldorf

4.3. Comparison of Medium/Low Voltage Network Structure of Düsseldorf and Madrid

The first thing to note is that the number of inhabitants is significantly higher in Madrid than in Düsseldorf (4.2 million versus 586.200) and therefore all figures will be higher in relation to demand, production, infrastructure, etc.

Once reviewed this, we proceed to list the features to compare:

1. Voltages

We can see in the following picture how the voltages are not exactly the same between both cities:

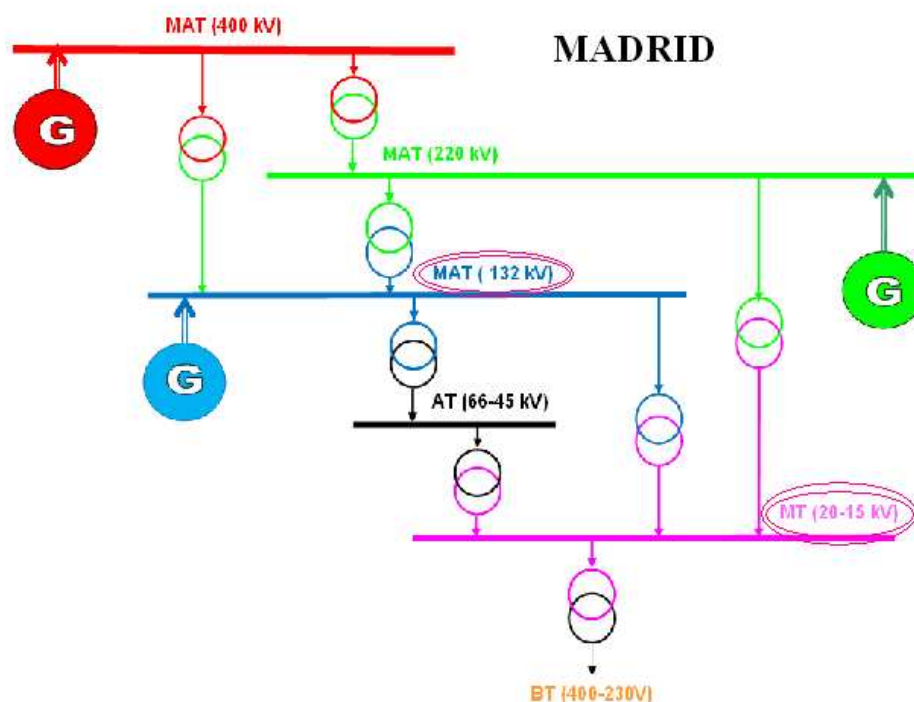

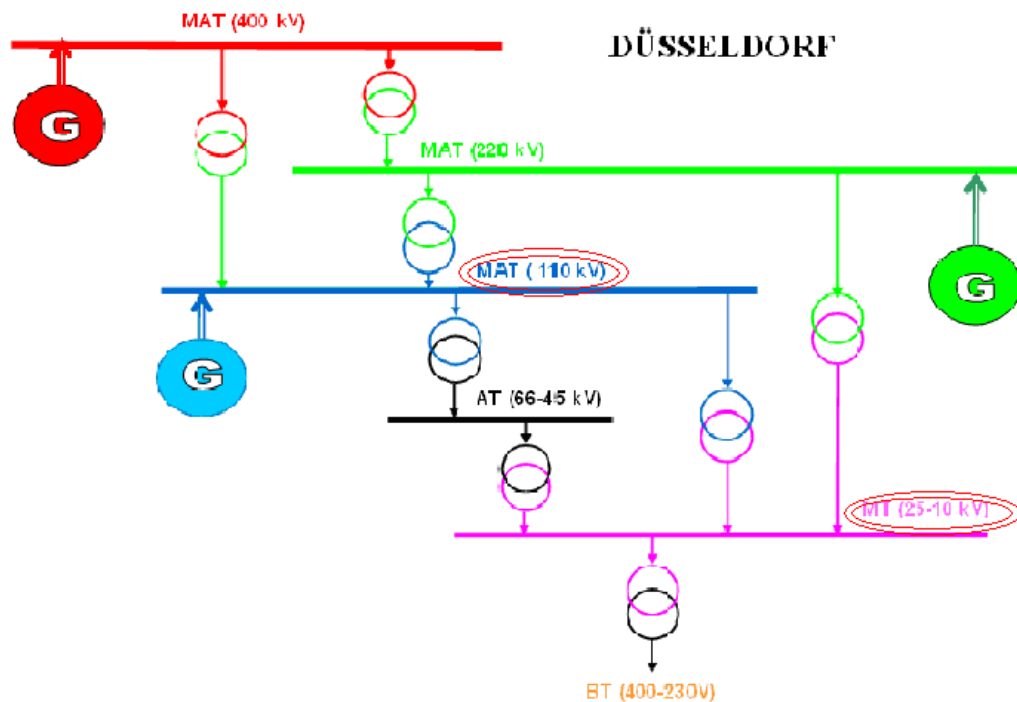

Figure 34: “Comparison Düsseldorf/Madrid Network”

As we can see, the first major difference is that while in Madrid transport of energy at very high voltage is performed at 132 kV, in Düsseldorf occurs at 110 kV.

This can be justified as they need to transport the high voltage power over long distances while minimizing losses and maximizing the power transported.

A voltage increase means a decrease in current through the line to carry the same power and therefore heat losses of the conductors and electromagnetic effects. A higher voltage, lower intensity and, consequently, lower energy loss, which is very important if we take into consideration the fact that power lines are often long distances.

In addition, a greater intensity requires more drivers section, and therefore a higher weight per unit length.

For all these factors, it raises voltage’s transport, reducing the intensity and lowering transport costs.

We appreciate that in Madrid this voltage is greater because, as we will see, the lines are longer and require more transportation energy as demand increases.

In medium voltage the values are also different, while in Madrid distribution lines are to a tension between 15-20 kV in Düsseldorf they are at a voltage between 10-25 kV.

In relation to this, we can say that the capability to distribute energy is higher in Düsseldorf than in Madrid despite being a smaller city.

2. Length of the Lines

We see clearly in the following comparative table as electrical lines are longer in Madrid than in Düsseldorf as the energy in the first city is transported from longer distances and in greater proportion.

| MADRID | DÜSSELDORF | |
|-----------|------------|-----------------------|
| 1.527 km | 130 km | HIGH VOLTAGE |
| 9.094 km | 3.383 km | MEDIUM VOLTAGE |
| 16.925 km | 3.462 km | LOW VOLTAGE |

Figure 35: Table length lines. Source: Stadtwerke Düsseldorf and Iberdrola

3. Substations

Here also we see as the number of substations is higher in Madrid than in Düsseldorf, of course, because of having a higher energy management. According to data provided by Stadtwerke Düsseldorf and Iberdrola Distribución we know that:

In Madrid there are 15.751 centers of energy transformation (processing centers) of medium to low voltage and 5.212 particular or private substations. There are also 2.029.359 counters.

In Düsseldorf there are 2.700 centers of energy transformation (processing centers) which belong to Stadtwerke Düsseldorf and 1100 particular or private substations. There are also 433.701 counters.

4. Transformers

Here we find similarities between the two cities because both use transformers of 630 KVA for the most part though each city has its peculiarities:

MADRID:

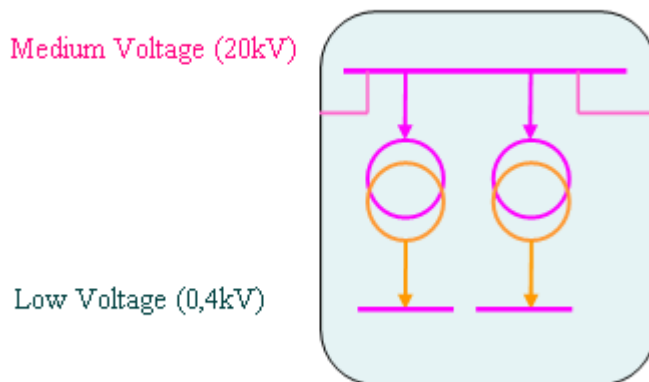

Figure 36: “MV/LV Transformer in Madrid” Source: Iberdrola Distribution

As we saw in the previous description, the typical configuration is two transformers per substation with a capacity of 630 kVA each.

DÜSSELDORF:

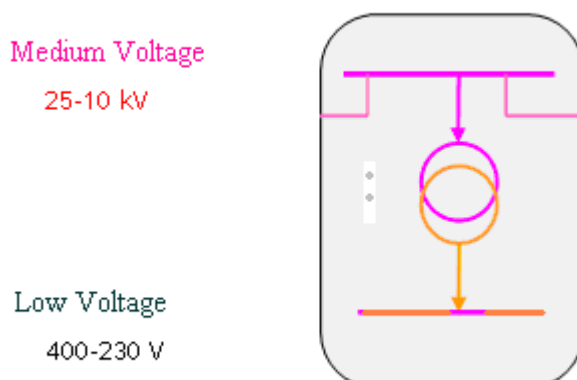

Figure 37: “MV/LV Transformer in Düsseldorf” Source: Stadtwerke Düsseldorf

The typical configuration in this case is a transformer per substation as there are 2800 transformers for 2700 substations. 1500 of these transformers are rated at 630 kVA and the other nearly all have a capacity of 500 kVA.

5. Energy Management

In **Madrid** the energy demand is covered as follows (according to REE):

35.6% Renewable Energies

16.6% Nuclear

47.8% Fossile and other energy forms

According to the Aragonese Institute of Statistics (data for 2009), in the same city 36 GWh is generated by Hydropower and 1677 GWh in special regime (Combinated Heat and Power, waste treatment, biomass, solar energy and wind power).

In **Düsseldorf** the energy demand is covered as follows (according to Stadtwerke Düsseldorf):

27.7% Renewable Energies

19.8% Nuclear

52.5% Fossile and other energy forms

According to Stadtwerke Düsseldorf (data for 2009), 1553704 MWh were generated in the city itself, particularly in Lausward production plant and Flingern power plant.

The following graph shows visually the proportion of each energy source used to meet demand:

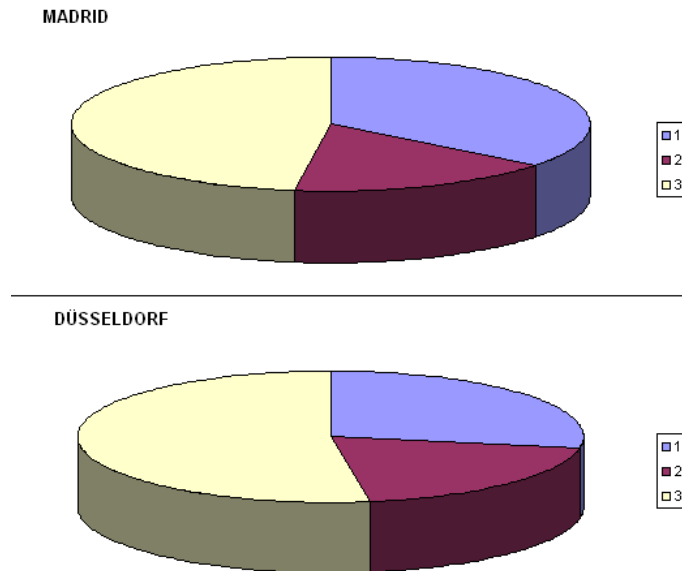

Figure 38: “Graph of energy sources”

Where number one in blue is for Renewable Energy, number two in maroon corresponds to Nuclear Energy and number three in beige color corresponds to Fossil and other forms of energy.

Düsseldorf note that the percentage of energy produced by Fossil fuels and Nuclear energy is higher than in Madrid while the percentage of energy produced by Renewable Energy is higher in Madrid. Both, in this order, produce more energy from Fossil fuels, followed by Renewable Energy and Nuclear Energy finally. We see that although the percentages are different, they are close.

Let us focus now on demand. According to the Aragonese Institute of Statistics, the total demand in Madrid in 2009 was 30.528 GWh while in Düsseldorf, according to Stadtwerke Düsseldorf, the total demand in 2009 was 2.657.250 MWh.

These data are logical to be considerably more numerous population Madrid than Düsseldorf. But if we make a more thorough analysis, such as calculating the consumption per capita per year will get the following results:

MADRID:
$$\frac{30528 \cdot 10^6 \text{ kWh}}{4,2 \cdot 10^6 \text{ hab}} = 7.269 \text{ kWh / hab}$$

DÜSSELDORF:
$$\frac{2657250 \cdot 10^3 \text{ kWh}}{586200 \text{ hab}} = 4.533 \text{ kWh / hab}$$

(data provided by Stadtwerke Düsseldorf told us that the average consumption per capita and year is 4.528 kWh in Düsseldorf, to be exact)

It is curious that, according to UNESA (Spanish association of electric industry), as seen in the table below, per capita consumption in Germany is higher than in Spain:

Consumo de electricidad “per capita” de los países de la Unión Europea

| | Consumo “per capita” (kWh/hab) |
|-----------------|-----------------------------------|
| Luxemburgo | 13.703 |
| Bélgica | 8.313 |
| Francia | 7.965 |
| Austria | 7.698 |
| Holanda | 7.032 |
| Alemania | 6.744 |
| Eslovenia | 6.391 |
| República Checa | 6.131 |
| España | 5.721 |
| Italia | 5.629 |
| Eslovaquia | 4.881 |
| Grecia | 4.774 |
| Portugal | 4.736 |
| Hungría | 3.893 |
| Polonia | 3.422 |
| Media | 6.149 |

Fuente: UNESA.

Figure 39: “Per capita consumption table”

Source: UNESA

But if we focus our attention on our subject, which is the comparison between Düsseldorf and Madrid, we note that a resident of Madrid consume about 1.6 times more than an inhabitant of Düsseldorf, which is a big plus for the city Düsseldorf because it is an indicative of the social consciousness of the importance of saving energy.

5. NEPLAN SIMULATIONS OF POWER SYSTEMS WITH ELECTROMBILITY

With the program called Neplan and with data supplied by the company Stadtwerke Düsseldorf concerning the network architecture of this city, we will study the results of the load flows on a small part of the Düsseldorf network located in the south of the city (Haberstrasse Wersten) to the massive influx of electric cars.

For this study we assume a standard battery of 30 kWh which is the most usual used in the available electric cars nowadays. The instantaneous power consumed depends on the recharge time, so we will see five different cases that are a slow recharge of 8 hours, the intermediate recharges (4 hours and 2 hours) and two fast recharges of 1 hour and 20 minutes.

Because we only have a demo version of Neplan, we cannot study the most real case according with the data from Stadtwerke that would be 3 lines for each transformer, each line with 10 loads for the houses and 10 loads more for the electric vehicles in the case that each house had just one electric vehicle. So we have decided to study a single line with 20 loads, 10 for houses and 10 for the electric vehicles, for each kind of recharge.

However, to show that the transformer could support the 3 lines with all electric vehicles connected with the fast recharge at the same time, we have also done a study with 3 lines but with half elements and the double load, due to the demo version doesn't allow put more than 30 elements. This is the most real case that we could simulate with this program. We will see this section at the end of this chapter.

We will start seeing the flow load of this part of the Düsseldorf network **without electric cars**, with an average consumption per household of 6 kW. The result is as follow:

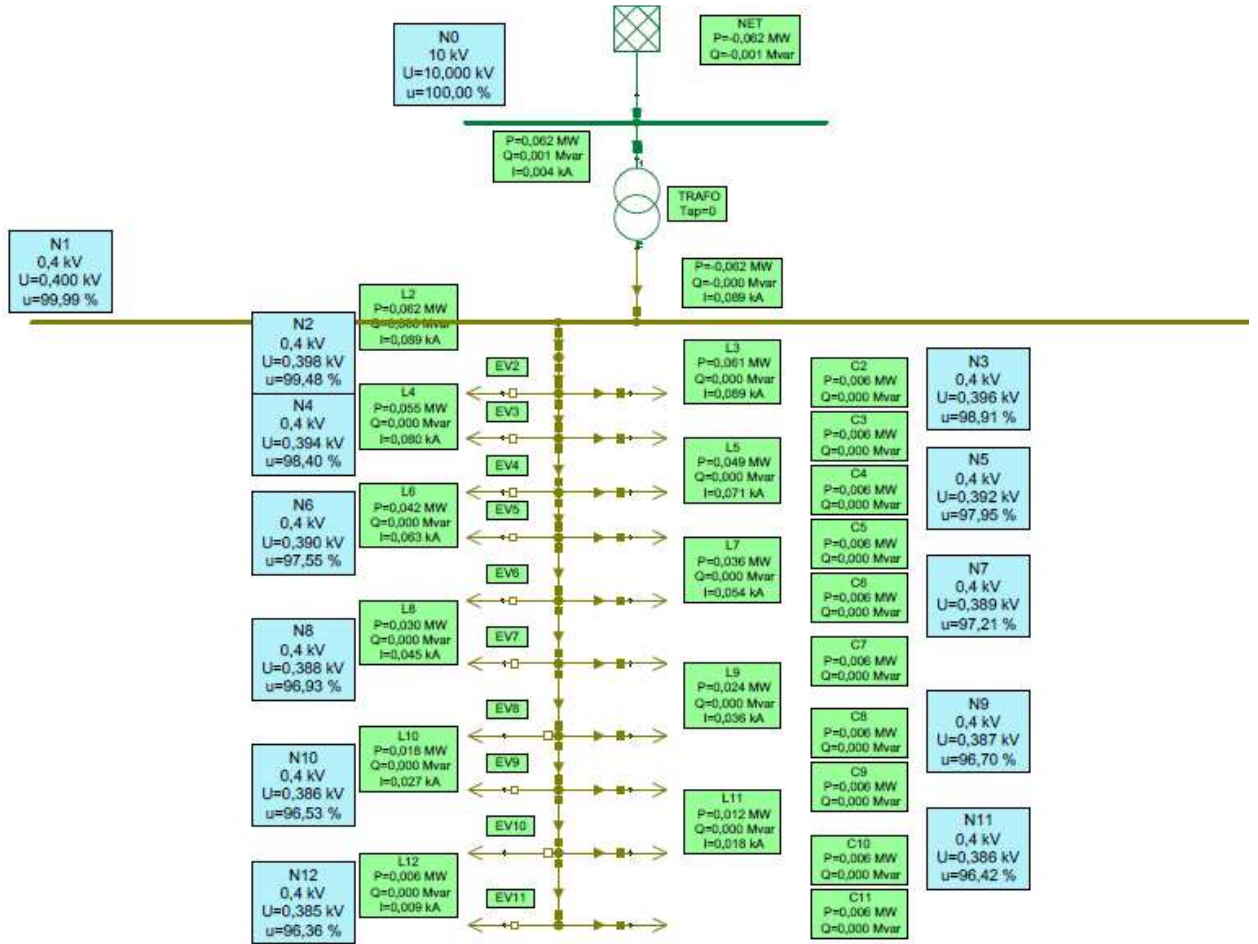

Figure 40: "Load flow without Electromobility"

All parameters are within limits, as well as the voltage in the last node (more than 90%) and the supported current of the cables.

Then we will see the results of the **slowest recharge** which during **8 hours**. To calculate the instantaneous power consumed for the battery we have done the follow calculation:

$$\frac{30kWh}{8h} = 3,75kW$$

So according to there is only one electro vehicle in each home, we have 10 loads of 6 kW for the houses and 10 loads more of 3,75kW for each car.

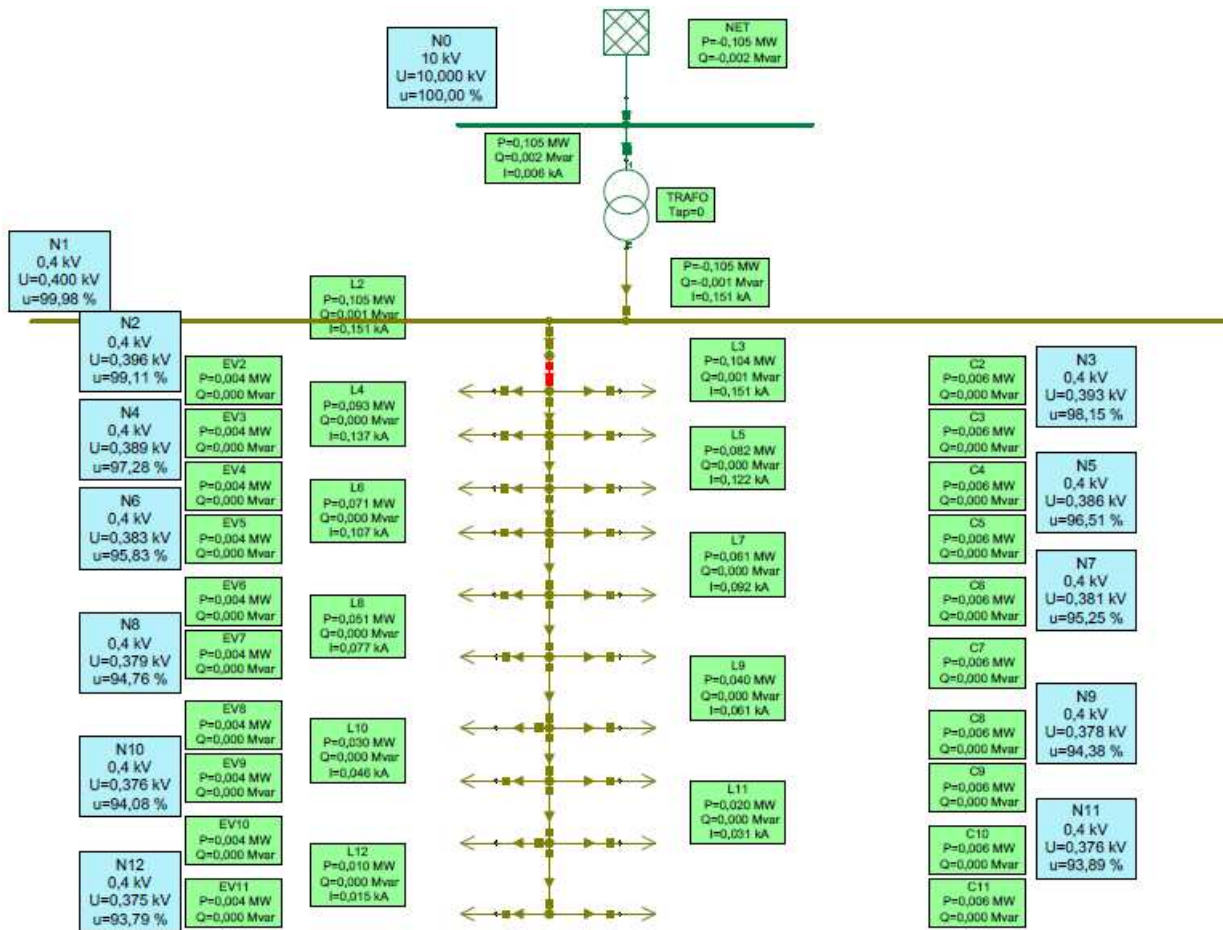

Figure 41: "Load Flow with slow recharge"

We can see the voltage on the last node is within the limits too, but a section of the line cannot support the current flowing. We will see the possible solutions to this problem in the next chapter.

The next case is with a recharge of **4 hours**:

$$\frac{30kWh}{4h} = 7,5 kW$$

So changing the value of the electric cars loads, we get the following results:

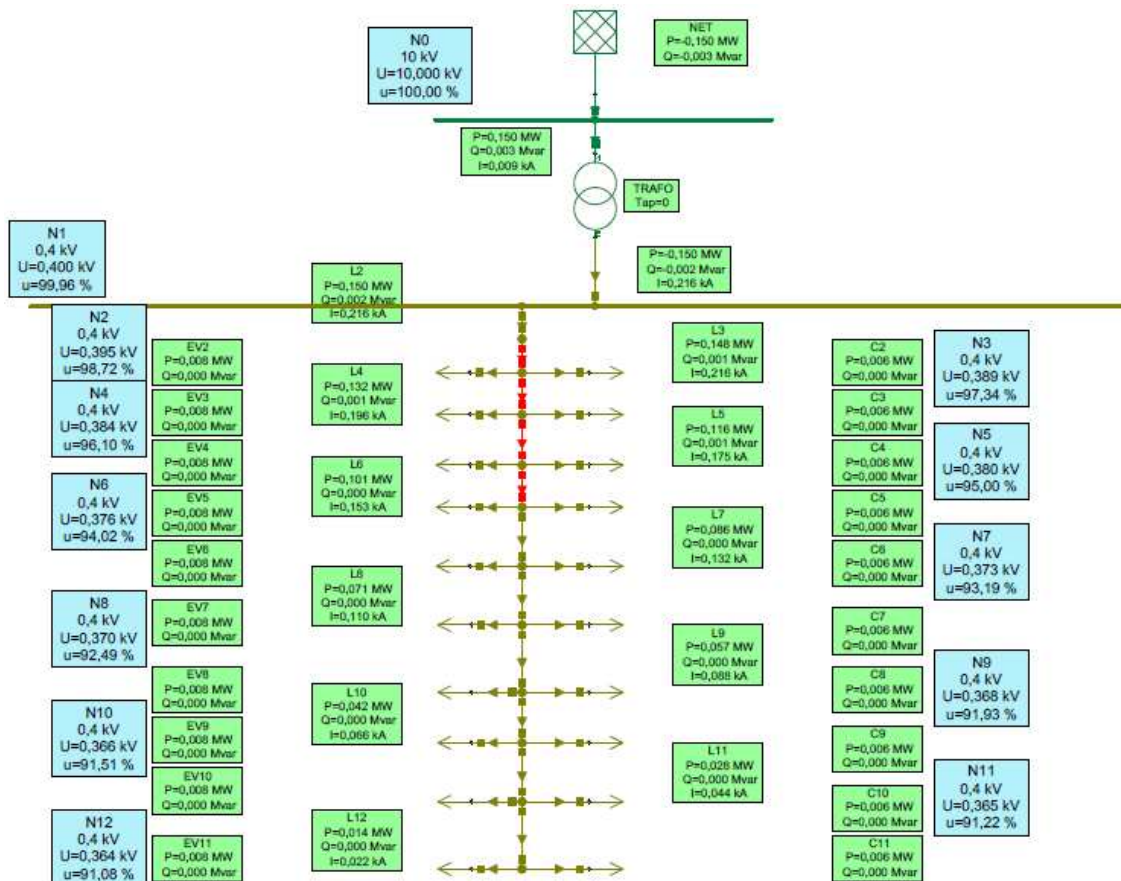

Figure 42: "Load Flow with 4 hours recharge"

With this kind of recharge the voltage level on the last node is also within the limits (bigger than 90%), but we have problems in four parts of the line, because if the power demand increase keeping the same voltage level, the current will be bigger so some parts of the line couldn't support that current.

So as we said previously, we will see possible solutions in the next chapter.

If we want to recharge cars with this type of battery in **2 hours**, the demand of each car will be:

$$\frac{30kWh}{2h} = 15 kW$$

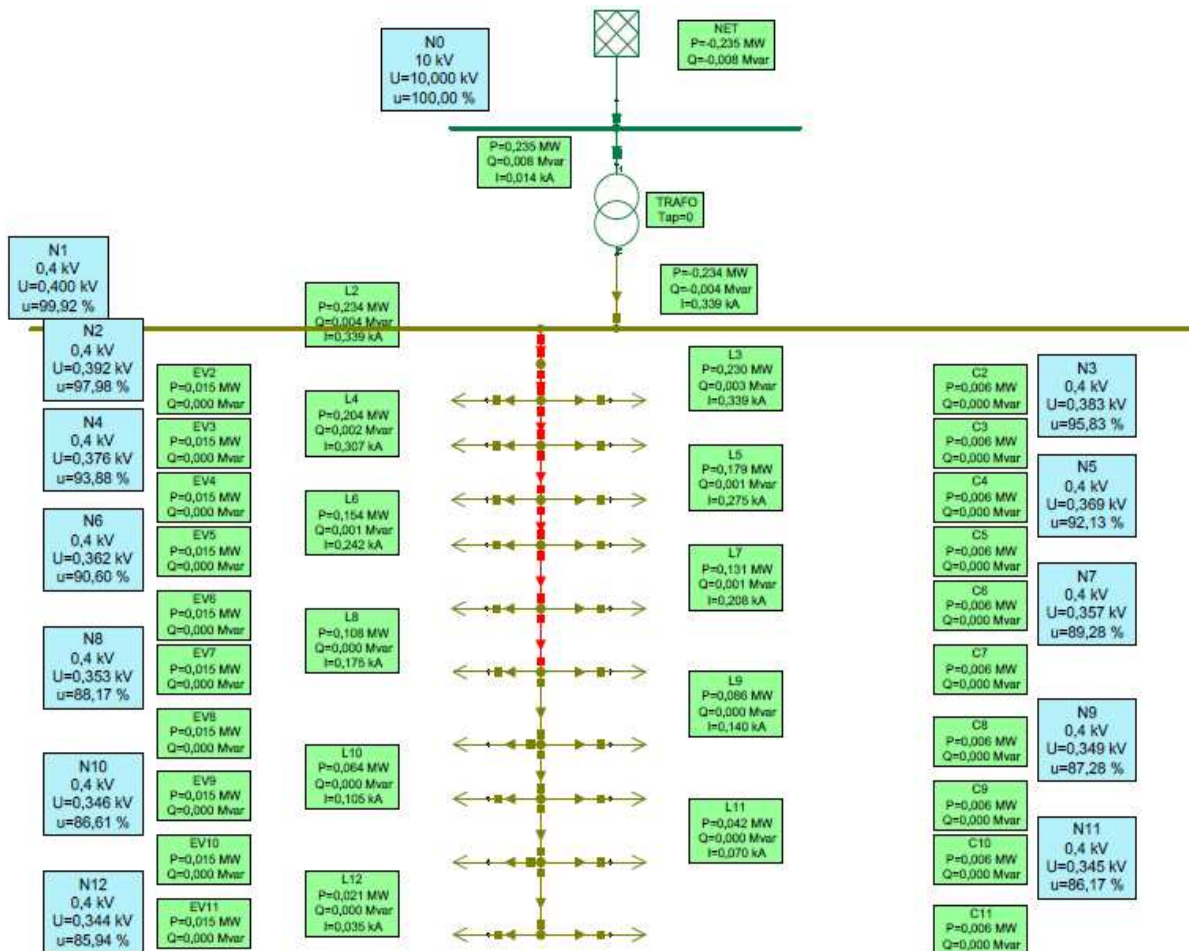

Figure 43: "Load Flow with 2 hours recharge"

As we can see, in this case there are 7 parts of the line where is flowing more current than the cables can support and also the voltage on the last node falls below 90% that is a problem for the company that distributes the electricity because they have to ensure a voltage level 90% above the nominal value for all consumers.

Can previsa that with a faster recharge, the voltage level will fall more and the line current will be higher. We can see it in the results for a recharge of **1 hour** and 30 kW:

$$\frac{30kWh}{1h} = 30 kW$$

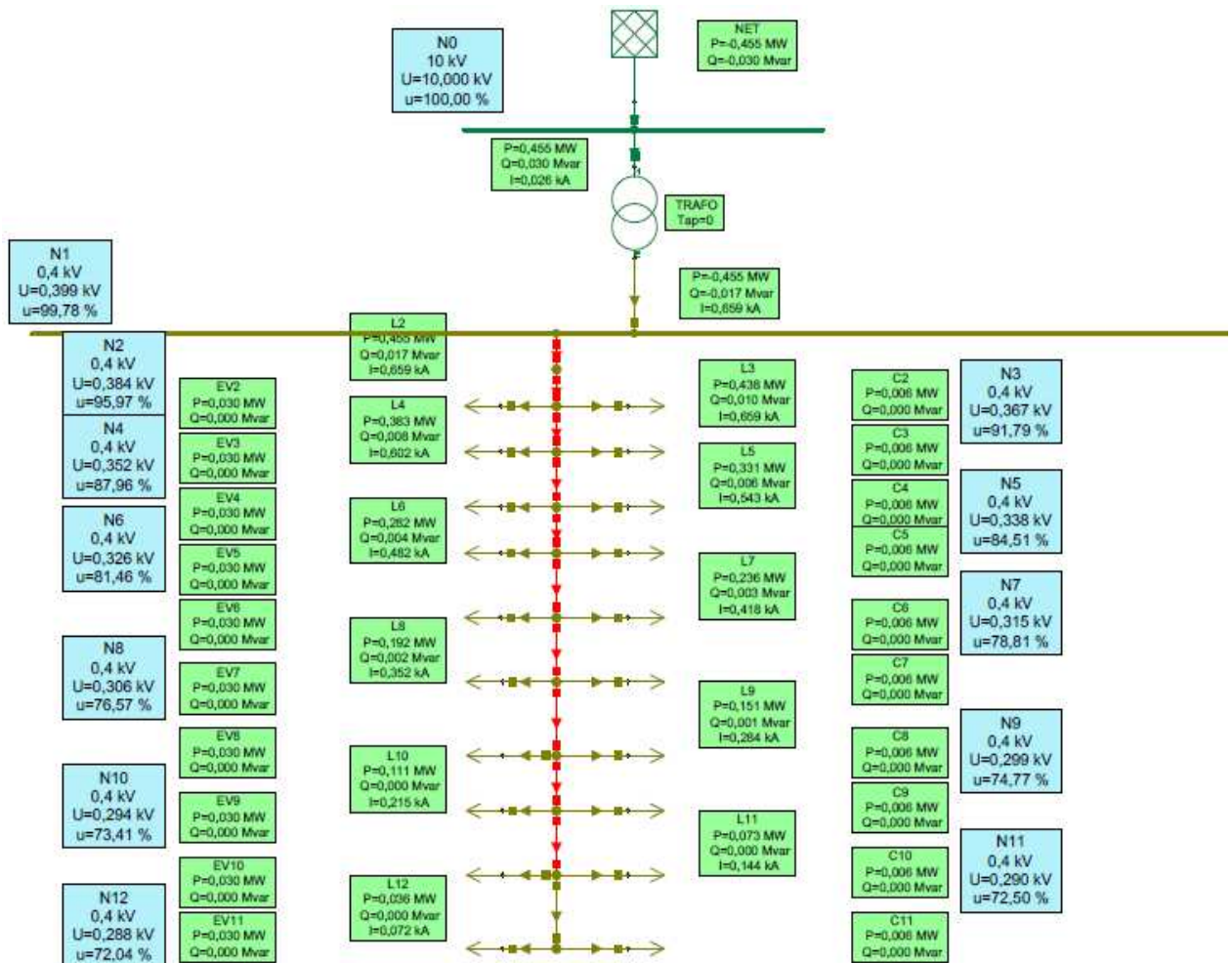

Figure 44: "Load Flow with 1 hour recharge"

In this case the voltage level fall until 72,04% on the last node and only one section of the line can support the flow current, so we need real solutions for make possible the fast recharges of the electric vehicles.

The last recharge example is the **fastest** one which during only **20 minutes** but cause serious problems to the network.

$$\frac{30kWh}{1/3h} = 90 kW$$

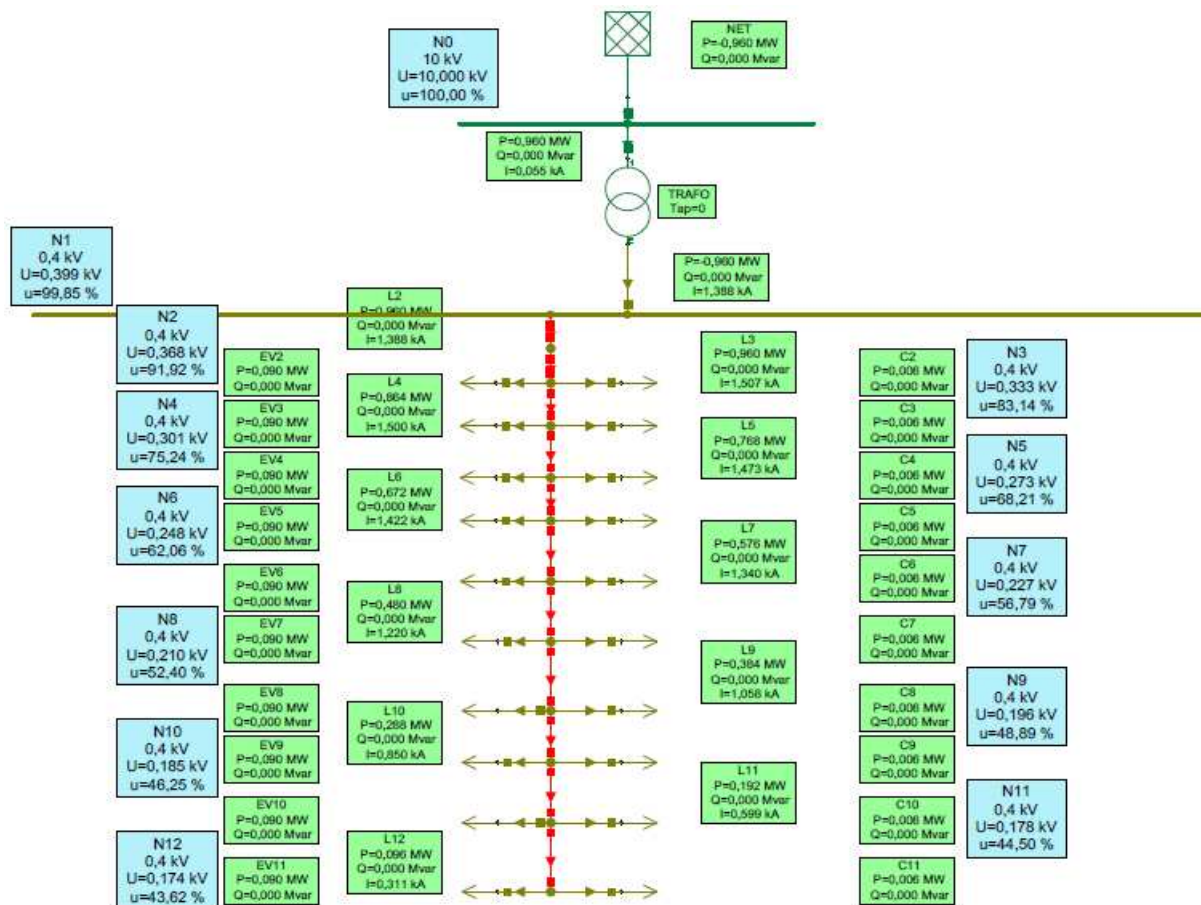

Figure 45: “Load Flow with 20 minutes recharge”

In this case the program gave problems because the voltage on the last node is very low (43,62%) and also the current very high for these type of cables.

Before go to study the solutions for the problems in the network that we have get with the program and could make possible the integration of the electric cars in the net, we will see if the transformers could support the actual configuration with 3 lines for each transformer, or they should replaced for another bigger if there was an electric car in every houses and every people wanted to recharge it at the same time.

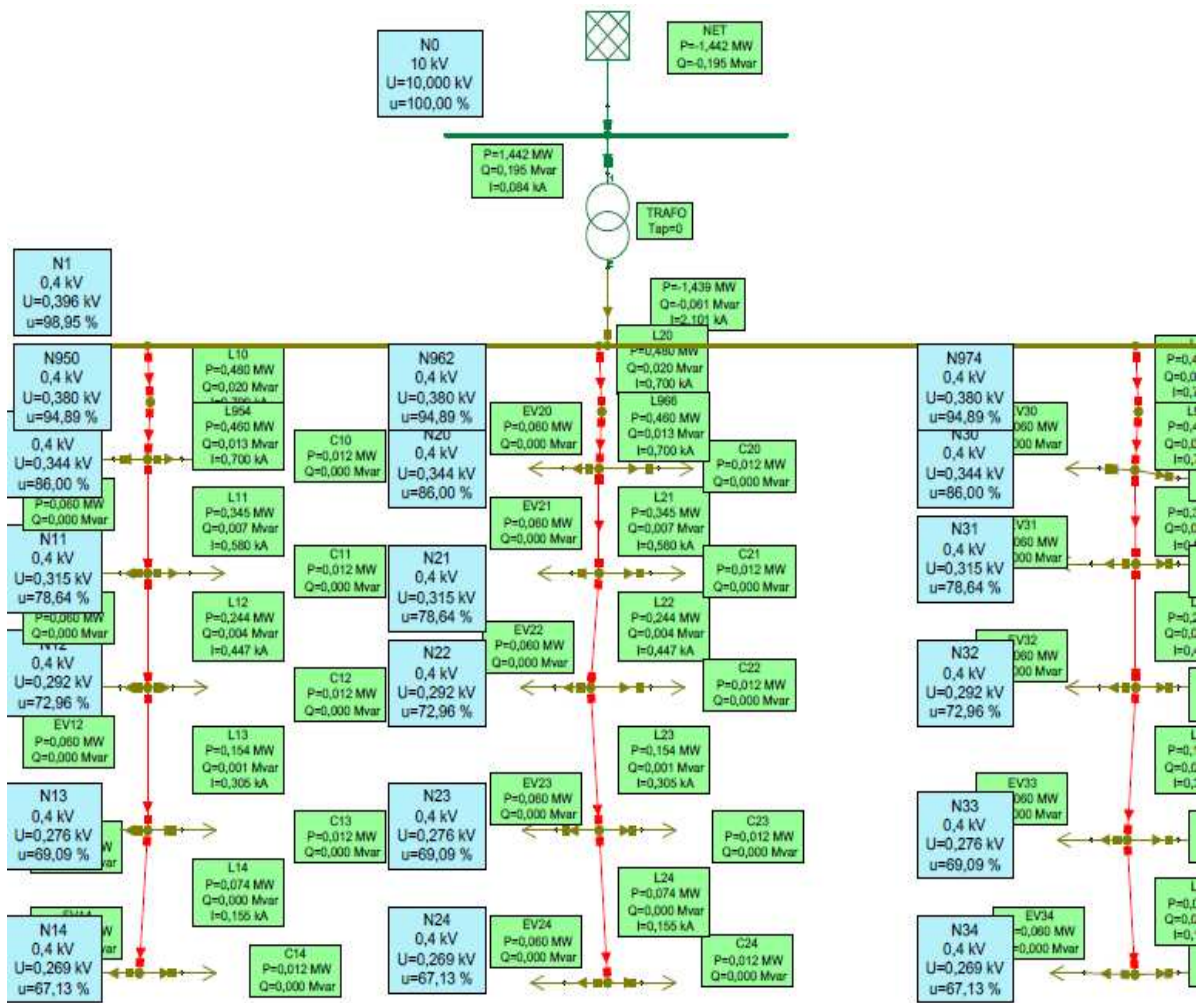

Figure 46: “Power System with Electromobility”

As we can see, the voltage on the last node is lower than with only one line for the same recharge (1h, 30kW) because each part of the line is longer, so there will be more voltage drop in each part.

We can see again that the flow current is higher than the cables can support, but the transformer doesn't have any problem with all the loads connected. It can provide the total power but maybe it would need more cooling than without electric cars.

6. TECHNICAL REQUIREMENTS OF THE NETWORK AS A RESULT OF ELECTRIC CARS

As we saw in the results with Neplan, we have problems in the cables because if all electric cars are connected at same time the current flowing through the cables will be higher than it can support, even with the slowest recharge (8 hours).

Also the electricity distribution company (in this case Stadtwerke Düsseldorf) would have problems to ensure a voltage level higher than 90% to the consumer on the last point of the line as law required.

For find possible solutions, we are going to see the results of each recharged with more detail.

If all cars do a **slow recharge of 8 hours**, only would be necessary change the second cable of the line for another one bigger that could handle the current that flow. It can support 142 amperes and with this kind of recharge flow 151 A, so change just this part wouldn't be so expensive because all of the others cables can support the current that is flowing and also the voltage level on the last node is within the limits (93,79%).

With a **recharge of 4 hours** the first cable can support the current but not the following four. The voltage level on the last node is 91,08% so it is within the limits, so this type of recharge could be viable changing the four cables for others bigger but do this operation would be expensive for the companies and as result the consumers could suffer a rise in the electricity price.

The three **quickest recharges** studied are not viable for the current urban infrastructure because in all the cases the voltage on the last node is out of limits and the flow current is so much higher than in the previous recharges, so it would need change mostly of cables for others bigger for support the current and with less impedance for reduce the voltage drop.

This work would be expensive so the better solution for can make possible the fast recharges is build charging points in public places, like supermarkets or garages of workplaces, with the infrastructure appropriate for supply the necessary power. So slow recharges may be make in the garages of the houses and fast recharges only may be make in the recharges points enabled for that use.

As for the slow recharges as for the fast recharges is necessary the implementation of a smart system in the recharges points that can make possible the connection between the electric vehicle and the net for a better energy management. This topic will discuss on the next chapter.

7. POSSIBLE FINAL SOLUTIONS FOR THE OPERATION OF THE ELECTRIC CARS

As we have seen, electric power systems are facing a major new challenge: the future integration into the grid of massive electric vehicle (EV).

In terms of the electric power system, EV can be considered as:

-Simple loads, when their owners simply define that the batteries must be charged at a certain rate;

- Dynamic loads/storage devices, if their owners define a time interval for the charging to take place, allowing some EV management structure to control that process.

If we understand EV as a simple load, it represents a large amount of consumed power, which easily can approach half the power consumed in a typical domestic household at peak load. Therefore, it is easy to foresee major problems of congestion on already heavily loaded networks and problems of tension in predominantly radial profile networks, especially if the peak periods coincide with EV charging periods.

There are two ways of adapting the presence of EV battery charging on distribution networks. The first is to plan for new networks in a way that can be handled completely new charges, regardless of the control scheme, which requires heavy investment in network reinforcement to do so. The second is to create an intelligent management system that fully integrates EV in the power system, the exploitation of the potential also to store energy and thus optimizing network investments. The latter is, of course, the way it should be done:

7.1.V2G networks. Intelligent Networks and Smart Grids:

V2G is an acronym for “Vehicle To Grid”.

Nowadays these type of networks are under consideration but if the electric car reaches the expected popularity, these intelligent networks are the next step to develop.

This technology allows energy’s storage in the valley hours and recovery of electricity at peak times from batteries of electric vehicles to the network.

V2G can charge the batteries during valley hours, when the kWh is cheaper, and sell to the grid at peak hours, when kWh is more expensive.

So, with the V2G everyone wins: the owners of the vehicles, electricity companies, society and the planet, although this requires creating an entire infrastructure no longer exists.



Figure 47: "Vehicle to Grid"

The charging of electric vehicles can be conductive or inductive. The conductive system is the direct connection to the network as simple as plugging vehicle through special high capacity cables with connectors that protect the high voltage conductor. Inductive coupling has the advantage of preclude any shock, but is more expensive and less efficient than the first. Inductive charging consists in that a few electric cars could be adapted to recharge simply by parking on a plate transmitting on the road. Citroën electric cars are already equipped with receiving plates under the car, allowing the vehicle to automatically recharge wirelessly.



Figure 48: "Conductive System" Source: Chinadaily



Figure 49: "Inductive System"

Source: Blog de Ingeniería en Redes y Tecnología Digital

Network provides power to the vehicle in AC mode. Normally, the charger converts AC mode into DC mode and provides energy properly to the batteries (from here is supplied to the engine and the wheels).

Some engines operate in AC mode, so that an investor must convert the DC of the battery.

As the price of energy is lower in valley periods, it would be usual to recharge the batteries at night. A Smart Grid with a large number of charging points in roads and parking areas with appropriate software would tell the car when to recharge, stop and even shed electricity to the network.

On average 95 percent of all cars are parked in a particular time, being used on average an hour a day. It would be desirable economic incentive (as we saw in the Chapter of Electromobility nowadays) for making the recharges in the valley hours and allow to use the energy stored in the batteries in case of need paying for that energy a higher price.

The intelligent load management, how to make the interconnection of charging points with the system supplier and a tariff model that is in line with the new demand, are the main challenges facing industry to make the electric car can also perform the function of regulator.

That is why electric vehicles can play a key role to start better manage the network, flattening the load curve, use the active reserve much of which is wasted (the amount of electricity available to ensure the immediate availability when needed by an unexpected increase in the demand) and permit an increase in the contribution of wind and other energy renewable, and may involve a restructuring of the electric and transport leading to new specialized companies.

An electric vehicle type, which runs some 17,000 miles a year, and makes recharge by 80% night rate, would spend about 800 euros a year in electricity. Travel the same distance with gasoline or diesel cost around 2,000 or 2,500 euros in fuel, given normal driving patterns.

The Californian Company AC Propulsion has been the first to develop electric vehicles with two-way communication with the network, the eBox, which incorporates TZero patented technology. This system allows bidirectional power flow for 50 or 60 Hz, allowing the vehicle's own battery provides power even to a house. It also allows the connection between vehicles (V2V, vehicle to vehicle) thus enabling to perform a roadside assistance to an electric vehicle that has run out of battery power by applying a fast charge.

When EV are required to make long trips, battery replacement stations will start appearing outside city areas, perhaps nearby main roads. The concept of “Electrolinera” born in the company Better Place, which has its headquarters in California. The idea is to have a service station for electric cars where they recharge batteries in about a minute through the exchange of their batteries.

7.2. Electric Car Battery Swap Station (ECBSS):

Such stations would consist of a robotic device completely change the car battery for a full load.

Explaining the process is entering a rail car wash type which will accommodate on a mechanism to remove the battery that is below the car and then mount the new one to go down a ramp as if nothing in no time.



Figure 50: “Better Place ECBSS”

Source: Noticias.coches

Better Place has the idea that all infrastructure necessary for the operation of the station is installed underground, and that the same store about 12 batteries with electrical connection to the network, to load all the stock within one hour. In the future we will see in California, Israel, Denmark and the main cities of Spain.

Undoubtedly it is an interesting idea but not very useful unless it is for a specific sector such as the carriers with fleets of cars as a normal user is not generally end up charging the car battery in a day, can get home and plug or relying on charging ports in public parking lots, shopping centers or their own offices.

The biggest problem is that all automakers would have to make their batteries and containers of them in a standard way to perform well throughout, but as we know the consensus between the marks seems impossible.

8. BIBLIOGRAPHY

- History of the electric car*, Paul A. Hughes; 1996
- Electric and Hybrid Cars*, Curtis Anderson and Judy Anderson; 2010
- www.gm.com ©
- Conference: “*Implementation of the Grid Integrated Vehicle with Vehicle to Grid Power*”, Willet Kempton; 2010
- Estrategia Integral para el impulso del Vehículo Eléctrico en España*; 2010
- German Federal Government’s National Electromobility Development Plan*; 2009
- www.electricandhybridcars.com ©
- www.tpub.com ©
- www.powerpulse.net ©
- www.vehiculosverdes.com ©
- www.treehuger.com ©
- www.reviewcar.com ©
- www.cocheseco.com ©
- Wegweiser Elektromobilität*, Dr. Thomas Becks, Prof. Dr. Rik De Doncker, Ludwig Karg, Prof-Dr.-Ing. Habil Christian Rehtanz, Andreas-Michael Reinhardt, Dr. Jan-Olaf Willums; 2010
- www.ree.com ©
- www.chinadaily.com ©
- www.unesa.es ©
- Tecnología del coche moderno*, Jeff Daniels; 2005

-[www.http://mpoweruk.com](http://mpoweruk.com) ©

-www.physorg.com ©

-www.satinfo.es ©

-www.batteryuniversity.com ©

-www.iberdrola.com ©

-*Automóviles eléctricos*, Emilio Larrodé Pellicer, 1997

9. ACRONYMS

EV: Electric Vehicle

R + D + i: Research + Development + innovation

R + D: Research + Development

DGs: Dirección General de seguros

C.S.I.E.: Conference and Industry Sector Energy

PHEV: Plug-in Hybrid Electric Vehicle

BEV: Battery Electric Vehicle

GIS: Gas Insulated Switchgear

ST: Substation

TC: Transformation Center

UNESA: Asociación Española de la Industria Eléctrica (Spanish Association of the Electricity Industry)

AC: Alternating Current

DC: Direct Current

10. SPANISH ABSTRACT

- **Introducción**

Como introducción a nuestro Proyecto hemos construido una tabla en la que podemos ver resumidamente los comienzos y la evolución del coche eléctrico, dónde tuvieron lugar las primeras construcciones de estos vehículos y el diseñador ó fabricante correspondiente:

| AÑO | DISEÑADOR/FABRICANTE | LUGAR | CARACTERÍSTICAS |
|------|---|---------|--|
| 1828 | Ányos Jedlik | Hungría | Modelo de coche a pequeña escala propulsado por un motor eléctrico |
| 1834 | Thomas Davenport | USA | Pequeño modelo de coche con una pista circular electrificada |
| 1835 | Sibrandus Stratingh Christopher Becker | Holanda | Coche eléctrico a pequeña escala propulsado por células primarias no recargables |
| 1838 | Robert Davidson | Escocia | Locomotora eléctrica que alcanzaba una velocidad de 6,4 Km/h |
| 1839 | Robert Anderson | Escocia | Carruaje eléctrico |
| 1865 | Gaston Plante | Francia | Primera batería recargable |
| 1867 | Franz Kravogl | Austria | Vehículo de dos ruedas propulsado por un motor eléctrico |
| 1881 | Gustave Trouvé | Francia | Automóvil eléctrico de tres ruedas |
| 1884 | Thomas Parker | England | Innovaciones tales como electrificar el metro de Londres |
| 1899 | Camille Jénatzy | Belgium | “Jamais Contente”, vehículo eléctrico que superaba los 100 km/h |

- **Motivación de este Proyecto**

Los motivos que nos han impulsado a realizar este Proyecto sobre el coche eléctrico son diversos ya que este tipo de vehículos aportan muchas ventajas, no sólo medioambientales sino también a la Red.

Algunas de ellas son:

- Mejoran la eficiencia energética del vehículo.
- Reducen las emisiones de CO₂ y, por tanto, contaminan menos. También producen menos ruido y por tanto disminuye la contaminación acústica.
- Reducen la dependencia del petróleo.
- A largo plazo resulta más rentable pues la electricidad es más barata que la gasolina.
- Contribuyen a aplanar la curva de demanda y por tanto a mejorar la eficiencia del sistema. Para ello los consumidores deberían recargar sus coches en las horas valle.
- Facilitan la integración de las energías renovables bajo condiciones de seguridad.

Aunque el vehículo eléctrico tiene muchas ventajas aún no ha alcanzado el éxito esperado pues cuenta con algunos inconvenientes que, poco a poco, se están tratando de resolver:

- La necesidad de recargar la batería, lo cual crea en el consumidor cierta dependencia pues tiene que estar pendiente en todo momento de la energía de la que dispone y del tiempo necesario para recargar la batería.
- Las baterías de estos coches son muy pesadas y ello reduce la eficiencia del coche. Por ejemplo, la batería del Tesla Roadster pesa unos 450 kilogramos lo cual afecta al funcionamiento del vehículo. Actualmente se están llevando a cabo muchos proyectos de investigación y desarrollo para conseguir baterías cada vez menos pesadas y con más capacidad.
- Por su construcción, el vehículo eléctrico es mucho más caro que uno con un motor convencional. También el hecho de que hay que cambiar la batería cada 3 ó 4 años lo encarece. Los gobiernos tratan de solventar este problema dando subvenciones a los usuarios de este tipo de vehículos.
- La autonomía del coche, es decir, la distancia que es capaz de recorrer con una sola recarga, la cual puede ir desde los 200 km hasta los 400 km dependiendo del vehículo.

Como vemos, la batería es el principal inconveniente del coche eléctrico y en este Proyecto estudiamos los tipos de baterías con las principales características de cada una para ver cuál es la más idónea dependiendo de las necesidades. También estudiamos las soluciones para los problemas tales como la autonomía o la posible sobrecarga de la Red.

- **Electromovilidad hoy en día**

- Electromovilidad en España

A principios de 2010 varias empresas españolas formaron unos grupos de trabajo para la elaboración del PLAN INTEGRAL ESTRATÉGICO PARA LA PROMOCIÓN DEL VEHÍCULO ELÉCTRICO EN ESPAÑA, con el propósito de promover la electromovilidad en este país. El objetivo de este plan es facilitar la integración del vehículo eléctrico de tal manera que el 2014 haya circulando en España 250000 unidades de este tipo de vehículos.

Para ello algunas de las medidas tomadas según este plan son:

- Dar ayudas económicas a los usuarios de los vehículos eléctricos y facilitar en la medida de lo posible la adquisición de uno mediante subvenciones.
- Dar ventajas al coche eléctrico con respecto a los coches con motor convencional tales como reducción de impuestos, aparcamientos y circulación preferente en la vía pública ó acceso a áreas restrictivas por parte del vehículo eléctrico.
- Programas de investigación, desarrollo e innovación así como la industrialización a gran escala del coche eléctrico y de sus componentes.
- Habilitar la infraestructura necesaria para la recarga de las baterías en el mayor número de zonas posible, tanto públicas como privadas.

- Electromovilidad en Alemania

En 2009 se creó en Alemania un plan estratégico llamado PLAN NACIONAL DEL GOBIERNO FEDERAL ALEMÁN PARA EL DESARROLLO DE LA ELECTROMOVILIDAD cuyo objetivo era que el país germano fuera líder en Electromovilidad. Se espera con ello un total de un millón de coches eléctricos en las carreteras alemanas para el año 2020. Este plan está estructurado en fases con distintos objetivos a corto plazo en los cuales se pretende preparar el mercado primero, luego propulsar la venta de estos vehículos y por último la producción masiva de ellos mediante la investigación y el desarrollo de las baterías, la habilitación de la infraestructura y la promoción en el área de las ventas y el mercado.

➤ Comparación entre las estrategias España/Alemania

La principal diferencia entre los dos tipos de estrategia es el objetivo perseguido puesto que mientras que en España se pretende la simple promoción del vehículo eléctrico, en Alemania quieren ser líderes mundiales en Electromovilidad. También se diferencian en la estructura pues en el plan español están las acciones a desarrollar y en el alemán además se nombran los objetivos a alcanzar incluyendo las fechas en las cuales se pretenden llevar a cabo. Ambos planes dan suma importancia a la investigación y desarrollo del vehículo eléctrico y hacen hincapié en dar el mayor número de ventajas y comodidades a los usuarios de éste.

- **Detalles técnicos de los coches eléctricos**

- Tipos de Baterías

En este capítulo han sido estudiados los diferentes tipos de baterías disponibles y en desarrollo, que son:

- Plomo-Ácido
- Níquel-Cadmio
- Níquel Metal Hidruro
- Ion-Litio
- Polímero Litio
- Zebra
- Zinc-Aire

Como resumen a las características de cada una de ellas vemos la siguiente tabla:

| Tipo de Batería | Densidad Energética (Wh/kg) | Energía/Volumen (Wh/litro) | Potencia/Peso (W/kg) | Vida útil (Ciclos) | Eficiencia Energética % |
|-----------------|-----------------------------|----------------------------|----------------------|--------------------|-------------------------|
| Plomo-Ácido | 30-40 | 60-75 | 180 | 500 | 70-80 |
| Níquel-Cadmio | 60 | 60-150 | 180 | 500 | 82 |
| NiMH | 70 | 143-300 | 250 | 1000 | 60-70 |
| Li-ion | 200 | 270 | 1800 | 1000 | 80-90 |
| Polímero Litio | 200 | 300 | 3000 | 1000 | 90 |
| Zebra | 120 | 300 | nd | 1000 | 99 |
| Zinc-Aire | 370 | 750 | nd | 1000 | 99 |

➤ Aspectos Constructivos

Dada a la escasa infraestructura existente para realizar las recargas eléctricas y al alto coste de los vehículos puramente eléctricos, la introducción de la Electromovilidad está vinculada a una primera integración de vehículos que no dependan completamente de la red eléctrica para su funcionamiento. Así en este capítulo hemos tratado de mostrar las características, ventajas e inconvenientes de los vehículos Híbridos, Híbridos Enchufables y Eléctricos Puros.

Híbrido: poseen un motor térmico y otro eléctrico y no se pueden enchufar a la Red para recargarlos. Las baterías son recargadas mediante el motor térmico y existen tres posibles formas de conectar ambos motores. La configuración en paralelo que es la más común ya que ambos motores pueden dar tracción al vehículo, la configuración serie en la que solo el motor eléctrico puede traccionar el vehículo y el motor térmico se usa únicamente para recargar las baterías, y por último el Híbrido Combinado que usa ambas (serie y paralelo) siendo la configuración en serie más propicia en velocidades bajas y la configuración paralelo para velocidades altas.

Híbrido Enchufable: reúnen las ventajas tanto de los híbridos como de los eléctricos puros ya que se pueden enchufar a la Red. Las configuraciones de propulsión y conexión entre el motor térmico y eléctrico son las mismas que para los Híbridos.

Eléctrico Puro: los vehículos eléctricos ofrecen una gran cantidad de ventajas frente a los vehículos de combustión como son la reducción de la dependencia del petróleo, la mayor eficiencia de estos, el menor coste de la energía necesaria para propulsar el coche, el menor mantenimiento al tener menos partes mecánicas así como la reducción de las emisiones locales de CO₂ y ruido. A pesar de todas las ventajas que ofrecen este tipo de vehículos, éstos también deben derribar barreras como la escasa autonomía, el elevado coste de las baterías y la infraestructura para recargarlos. Por todo esto el desarrollo de los coches puramente eléctricos se centra en coches para el uso diario en las ciudades que sean capaces de recorrer la distancia media diaria.

El bajo nivel de ruido de los coches eléctricos además de una ventaja puede ser un inconveniente para las personas ciegas, por lo que se está investigando para establecer un nivel mínimo de ruido para este tipo de coches.

- **Comparación de la Estructura de la Red de Media/Baja Tensión de Madrid y Düsseldorf**

En este capítulo primero se hizo un estudio de cada una de las redes por separado, la de Madrid y la de Düsseldorf, y luego se estableció una comparativa de la cual destacamos los siguientes aspectos:

-En Madrid el transporte de energía a muy alta tensión es a 132 kV y en Düsseldorf es a 110 kV y en media tensión los voltajes de distribución también son diferentes pues en Madrid están entre el rango 15-20 kV y en Düsseldorf 10-25 kV.

-Las líneas de transporte y distribución son significativamente más largas en Madrid que en Düsseldorf como podemos ver en la siguiente tabla:

| MADRID | DÜSSELDORF | |
|---------------|-------------------|----------------------|
| 1.527 km | 130 km | ALTA TENSIÓN |
| 9.094 km | 3.383 km | MEDIA TENSIÓN |
| 16.925 km | 3.462 km | BAJA TENSIÓN |

-El número de subestaciones de cada ciudad es notablemente más numeroso en Madrid, como se refleja en la siguiente tabla:

| MADRID | DÜSSELDORF | |
|---------------|-------------------|---|
| 15.751 | 2.700 | SUBESTACIONES MEDIA/BAJA TENSIÓN |
| 5.212 | 1.100 | CENTROS DE TRANSFORMACIÓN PRIVADOS |
| 2.029.359 | 433.701 | CONTADORES |

-La configuración en las subestaciones puesto que, aunque en ambas ciudades se utilizan mayoritariamente transformadores de 630 kVA, en Madrid las estaciones cuentan con dos transformadores mientras que en Düsseldorf sólo hay un transformador por subestación.

-La gestión de la energía en ambas ciudades pues Madrid produce más que Düsseldorf por energías renovables mientras que la ciudad alemana produce más en las centrales nucleares que la ciudad española.

-También es interesante saber que un ciudadano madrileño consume mucha más energía que un ciudadano de Düsseldorf pues el primero consume de media 7.269 kWh/año mientras que la media de consumo del segundo es de 4.528 kWh/año.

Las cifras respecto a longitud de las líneas y número de subestaciones son notablemente más altas en Madrid porque el número de habitantes es bastante mayor en esta ciudad: hablamos de 4.2 millones de habitantes (en nuestra zona de estudio, controlada por Iberdrola) frente a 586.200 habitantes en Düsseldorf. Otros factores como el alumbrado público también influyen en el crecimiento del consumo de energía de la ciudad española con respecto a la ciudad alemana.

- **Simulaciones con Neplan de los Sistemas de Potencia con integración de la Electromovilidad**

El objetivo de este capítulo es obtener resultados reales de los flujos de cargas con la integración de los coches eléctricos en la Red Eléctrica mediante simulaciones con Neplan y con los datos proporcionados por Stadtwerke Düsseldorf referentes a la infraestructura de la Red de Baja Tensión de esta misma ciudad.

Se ha considerado una media de un sólo coche eléctrico por casa con una batería de 30 kWh.

Ya que la potencia necesaria para la recarga de los coches eléctricos depende del tiempo de recarga, siendo mayor cuanto más rápida sea ésta, se han estudiado los siguientes casos: 8 horas, 4 horas, 2 horas, 1 hora y 20 minutos.

Después de hacer el flujo de cargas vemos que en la recarga más lenta, la de 8 horas, la compañía podría asegurar al consumidor un voltaje superior al 90% como marca la ley, pero una sección de la línea no podría soportar la corriente que circularía con todos los vehículos eléctricos recargando sus baterías a la vez y las casas consumiendo el máximo de potencia contratada que se ha supuesto de media 6 kW. Lo mismo ocurre con la recarga de 4 horas, ya que el voltaje en el último nodo está dentro de los límites pero la corriente es superior a la que soportan los cables.

En las recargas de 2 horas, 1 hora y 20 minutos, al requerir más potencia, el voltaje en el último nodo de la línea cae por debajo del 90% y la mayoría de las secciones de la línea no son capaces de soportar la corriente circulante.

Con estos resultados, veremos a continuación en el capítulo 6 las posibles soluciones para los problemas encontrados.

En último lugar es preciso mencionar que según se puede comprobar en el estudio original de los flujos de carga, los transformadores no supondrían ningún tipo de problema ya que podrían proporcionar sin problemas la potencia necesaria incluso con todos los coches eléctricos realizando la recarga más rápida (20 minutos).

- **Requerimientos Técnicos de la Red como resultado de la integración de la Electromovilidad**

Para las recargas más lentas (8 y 4 horas) sólo haría falta cambiar los cables de la línea que no pueden soportar la corriente que circularía con todos los coches eléctricos conectados, ya que el voltaje en el último nodo es superior al 90%.

En cambio el caso de las recargas de 2 horas, 1 hora y 20 minutos sería poco viable realizarlas en las casas ya que habría que renovar la mayoría de los cables debido a que además de los problemas con la corriente, el voltaje en el último nodo está fuera de los límites, por lo que este tipo de recargas sería más apropiado realizarlas en sitios habilitados para ello con puntos de recarga capaces de suministrar dicha potencia en establecimientos públicos como centros comerciales, garajes, etc...

Como se verá en el siguiente capítulo toda esta renovación de la infraestructura no sería necesaria con el uso del Smart Meter (Medidor Inteligente) ya que éste se encargaría de llevar a cabo las recargas inteligentes en los períodos en los que la demanda eléctrica es menor, por lo que el caso de que todos los coches y casas estuvieran consumiendo el máximo de potencia a la vez sería muy poco probable.

- **Posibles soluciones para la integración de la Electromovilidad**

- V2G Redes. Redes Inteligentes y Smart Meters

V2G son las siglas de “Vehicle to Grid” que, traducido al español quiere decir “Vehículo a la Red”. Esta tecnología permite almacenar energía en las horas valle y arrojarla a la Red en las horas pico. Se trata de un software muy sofisticado que comunica al vehículo con la Red y que le indica al propio vehículo cuándo debe de recargar su batería, parar de recargarla e incluso entregar energía dependiendo de la disponibilidad de la Red.

Gracias a estos medidores se aplanaría la curva de la demanda mejorando la eficiencia del sistema.

Este tipo de medidores inteligentes están ahora en pleno desarrollo pues sería la única forma de introducir masivamente coches eléctricos en las ciudades sin modificar la estructura de la Red ya existente aunque ya hay compañías como AC Propulsion© que ha sido la primera en desarrollar vehículos eléctricos con dos vías de comunicación con la Red y que permite al coche proveer de energía a una casa e incluso conectarlo a otro coche eléctrico para darle energía en el caso en el que éste se haya quedado sin batería.

- Electrolineras

La compañía Better Place© ha sido la encargada del desarrollo de este tipo de instalaciones.

Se trata de una estación de servicio que, en lugar de la convencional manguera y surtidores de combustible, ofrece la sustitución de la batería agotada. No se trata pues de recargarla -con la lógica espera- sino de reemplazar en apenas unos minutos la batería agotada por otra recargada.

El cambio se realiza sin tener que bajar el conductor del coche y se hace a través de una cadena automatizada que extrae la batería de la parte inferior del vehículo y la sustituye por otra totalmente recargada. Esa batería sustituida es conectada a la red y de nuevo recargada para instalarla en otro vehículo. De esta forma la espera se reduce a esos pocos minutos y es un sistema muy útil sobre todo para los trayectos largos que agotan la escasa capacidad de las baterías actuales.