

DEVELOPMENT OF PIEZOELECTRIC MICRO-ENERGY HARVESTING SYSTEM USING VOLTAGE DOUBLER

Mohammad G. Mostafa, S. M. A. Motakabber, Muhammad I. Ibrahimy and Tawfiqur Rahman
Department of Electrical and Computer Engineering, International Islamic University Malaysia, KL, Malaysia
E-mail: mostafauap@gmail.com, amotakabber@iium.edu.my, ibrahimy@iium.edu.my

ABSTRACT

Nowadays renewable micro-energy harvesting system is becoming attractive, because this energy is free which leads to reduce energy cost. Piezoelectric is one of the common energy harvesting systems. Generally, the output of a piezoelectric transducer is a small AC voltage and its power is also small. As a result, the conversion of this low AC voltage into DC voltage by using rectifier diode is not suitable since a cut-in voltage drop reduces the output voltage as well as power of the system. A micro-energy harvesting interface circuit has been developed by using voltage doubler to improve the performance. The design is a modified model of buck boost converter. In this technique, at first the input voltage is increased by a voltage double then it is used into a buck boost converter. A diode and a single capacitor have been used in this design instead of bridge rectifier which overcomes the diode conduction losses. 3.4V DC across a load 1k Ω is obtained when the output voltage of the piezoelectric transducer is 0.54V AC. The circuit has been simulated by using PSpice (V16.5) electronic circuit simulation software and maximum power dissipation 57mW is obtained at the load which is supposed to be better compared to other conventional designs.

Keywords: Energy harvesting, DC to DC converter, Micro-energy harvesting, Piezoelectric transducer, and Buck-Boost converter

INTRODUCTION

Energy harvesting (EH) is the process in which energy is extracted from the environment such as the vibration, solar, thermal and so on. There are three types of vibration based micro-energy generators such as electromagnetic, electrostatic and piezoelectric [1-2]. Among them, piezoelectric harvester has better performance in terms of energy density, therefore, its use is being increased rapidly. To design piezoelectric micro-energy harvesting (MEH) system, there are three key components that play a vital role in optimizing the energy. They are, (i) electronic interface circuit; (ii) temporary storage device and (iii) controller [3].

Micro-energy refers to the scale of energy in the micro-watt power range that can be harvested from the ambient sources. This energy is free which will lead to reduce in energy cost and reduce the dependency on battery system or fossil fuel. Harvesting energy from vibration based piezoelectric transducer is in the range of few μ W to hundreds of μ W [4]. Up-to-now, capturing this environmental energy adequately is not possible to fulfil the requirement of load. Therefore, it is needed to convert this energy into a usable electric energy to power up storage device or to operate in a battery-less system to overcome the frequent battery replacement problems.

Directly connected load circuit with the piezoelectric system is not desirable as the output power of the transducer is very low. Even if a bridge rectifier connected as an interface, the output performance will also be badly affected since input impedance of the capacitive piezoelectric transducers cannot be matched with rectifier impedance.

Piezoelectric transducer only generates an AC signal but the load circuit needs regulated DC. Two stage conversions are generally used: (i) bridge rectifier and (ii) DC to DC converter to regulate the output. But, these two stage conversion increases the converter cost and reduce the converter performance in terms of efficiency as the component numbers increased.

As the two-stage converter has faced the problem, therefore, to overcome the situation, direct AC-

DC boost converter can be implemented which could be appropriate for energy harvesting system. A dual polarity noble circuit has been designed that has bridgeless dual polarity boost converter [1]. This system uses two inductors, and two series connected capacitors. These two capacitors are charged in positive and negative cycle respectively. But this storage energy has been discharged to the load continuously as a result large voltage drop occurred in the capacitors. Large value of capacitors are needed to make the voltage ripple in a acceptable level. But, it makes the converter response very slow and makes the harvesting system impractical since the harvesting circuit has size limitation. Furthermore, this design has been faced complexity in control circuit because the converter requires to sense the input line polarity.

A parallel Boost and Buck-Boost converter was developed which output DC bus is split into two series connected capacitors and each of these capacitors is charged only for one half cycle [5]. The storage energy of these capacitors is discharged to the load continuously which causes large voltage drop across capacitors. Therefore, the harvesting of optimum energy from the transducer is still a crucial issue.

A new bridgeless converter, shown in Figure-1 that is a single polarity buck-boost and buck-boost converter, has been developed. This converter utilizes a capacitor to double the piezoelectric AC voltage. Proposed model is consisted of two buck boost converters which are connected in parallel. The output DC bus of this design is realized by using single capacitor which charged in both positive and negative half cycle. Therefore, it resolves the problems presented in the dual-polarity boost converter design [1].

BASIC PRINCIPLE OF ENERGY GENERATION

When a stress or strain applied on the piezoelectric material, the static charge inside the material will be built up. This charge will be redistributed to develop a potential which is the basic principle of energy harvesting system. Basic principle of energy generation has shown in Figure-1.

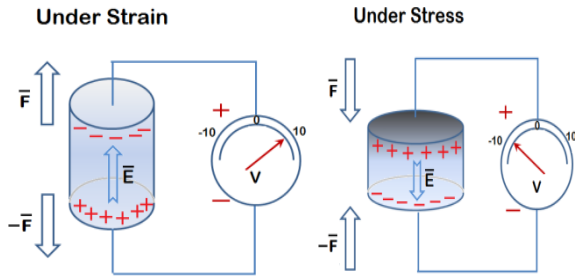

Figure-1. Basic principle of piezo-energy generation.

ENERGY HARVESTING

Basic principle of a piezoelectric energy harvesting is a process in which energy is extracted from the environment in the form of mechanical, solar and thermal energy. Then the extracted energy is converted into an usable electric energy for powering a battery-less system to overcome the frequent battery replacement problem. As the piezoelectric based micro-energy harvesting system has been starting to replace the use of conventional battery systems, therefore, use of micro-energy harvesting system has been increased dramatically in recent years. Besides that recent advancement of low power IC technology has opened up a new window of its application scope in many sectors such as micro-wireless sensor network, RFID and biomedical implants etc.

ANALYSIS OF PROPOSED CONVERTER BASED ON VOLTAGE DOUBLER

Proposed converter has been designed based on voltage doubler and two buck boost converters they are two distinct interfacing circuit. The converter extracts energy in both positive and negative half cycle of input voltage. The developed design is shown in Figure-2. Input voltage has been double by using doubler and the buck boost topologies are used to regulate the output voltage to fulfil the load requirement. Two NMOS switches (IRF 530), two inductances, three Shockley diodes and two electrolytic capacitor have been used in this design. Switching frequency is considered much higher than the input AC voltage frequency. For temporary storage, a 220 μF capacitor has been used. A voltage pulse signal is used to control the MOSFET switches. The components of the harvesting circuit has been presented in Table-1.

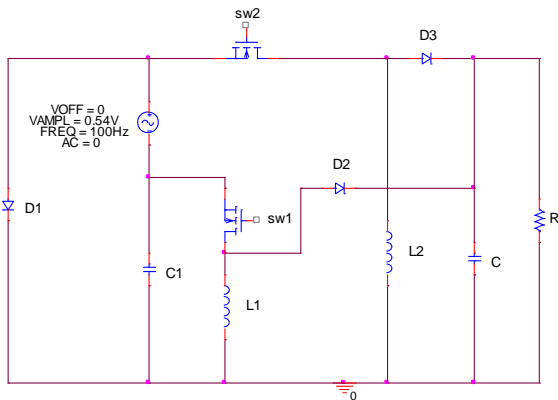

Figure-2. Proposed direct AC to DC converter.

Table-1. Components of the harvesting circuit.

Parameter Name	Parameter Value
Input voltage (Vin)	0.54 V AC with 100 Hz
Output voltage (Vo)	3.4 V (targeted voltage)
Switching Frequency	10 kHz
inductor	13 μH
Capacitors	470 μF and 220 μF
Diodes	D1N5830 and D1N5822
Load resistance (R)	1k Ω

Operation of the proposed design has been categorized in four modes. The modes 1 and 2 work for the positive half cycle and mode 3 and 4 work for the negative half cycle of the piezoelectric input signal.

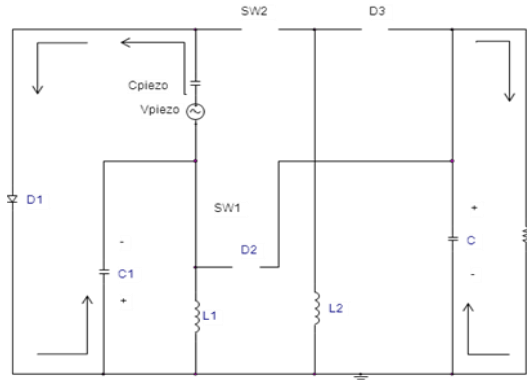

Figure-3. Mode 1 operation of voltage doubler.

Mode 1: At positive half cycle, Sw1 is turned on and Sw2 is turned off. Piezoelectric transducer input voltage will charge inductor L1 through diode D1 and the loop for mode 1 is $V_{\text{piezo}}-D1-$ parallel $L1C1$. Both diodes D2 and D3 are not conducting since the voltage in inductor L2 is less than diode cut-off voltage. In this stage, load circuit has been powered by storage capacitor C (Figure-3).

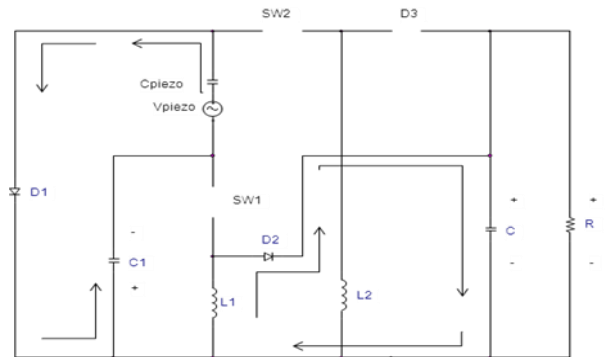

Figure-4. Mode 2 operation of voltage doubler.

Mode 2: The mode 2 work for the positive half cycle. Switch Sw2 is off. Now turned off the Sw1, then and at that stage D3 is non-conducting since the voltage in inductor L2 is less than diode cut-off voltage. Piezoelectric transducer input voltage will charge capacitor C1 through diode D1. This diode D1 has been used to pump the piezoelectric transducers output voltage. (Figure-4). Storage energy in inductor L1 at mode 1 will be discharged to the storage capacitor C. Diode D2 has

been used to block storage energy transferred to the inductor L1.

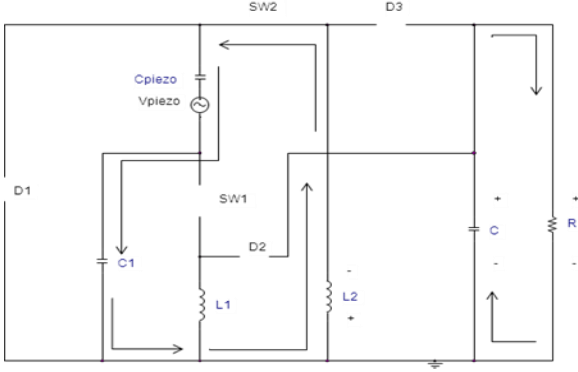

Figure-5. Mode 3 operation of voltage doubler.

Mode 3: In this state, Sw1 is off and D1, D2, D3 are non-conducting. Sw2 is turned on so that input energy is built up in inductor L2 and the conduction path is V_{piezo} -C1-L2. At this stage, L2 and C1 are series circuit. Energized capacitor C has discharge the energy to the load resistance (Figure-5).

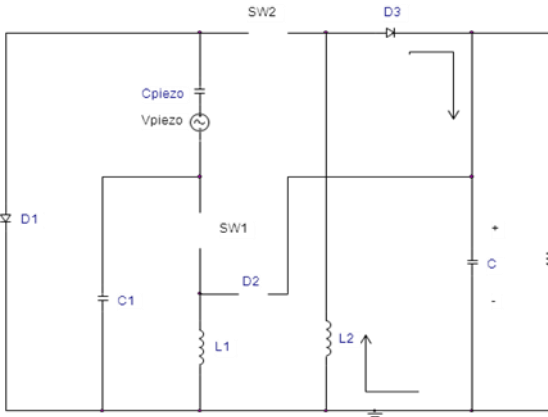

Figure-6. Mode 4 operation of voltage doubler.

Mode 4: In this mode, output voltage is in negative cycle. Sw1 and Sw2 is turned off. Two diodes D1, D2 are non-conducting. Stored energy in L2 has been discharged in storage capacitor C through D4. This diode D4 pump the inductor L2 energy and block the storage energy returned to the inductor L2.

MATHEMATICAL CALCULATION

The mathematical transfer function of the proposed design has been analysis. The MOSFET switch of the converter has been On-State from $t = 0$ to $t = DT$ and increase the inductor current. Therefore, rate of change of inductor current, ΔI_{LON} is:

$$\Delta I_{LON} = \int_0^{DT} dI_L = \int_0^{DT} \frac{V_{piezo} + V_{c1}}{L} dt = \frac{(V_{piezo} + V_{c1})DT}{L} \quad (1)$$

But at the turn Off-state, switch has been open from $t = 0$ to $t = (1-D)T$. Therefore, rate of change of inductor current, ΔI_{LOff} during the Off-period is:

$$\Delta I_{LOff} = \int_0^{(1-D)T} dI_L = \int_0^{(1-D)T} \frac{V_o}{L} dt = \frac{V_o(1-D)T}{L} \quad (2)$$

As the inductor current cannot change instantly, therefore, the inductor current variation during On and Off state should be sum of them. From Eqn. (1) and (2),

$$\begin{aligned} \Delta I_{LON} + \Delta I_{LOff} &= 0 \\ \frac{(V_{piezo} + V_{c1})DT}{L} + \frac{V_o(1-D)T}{L} &= 0 \\ \frac{(V_{piezo} + V_{c1})DT}{L} + \frac{V_o(1-D)T}{L} &= 0 \\ \Rightarrow V_o &= \frac{(V_{piezo} + V_{c1})DT}{(1-D)T} = 0 \end{aligned} \quad (3)$$

The input and output voltage relationship of the basic converter in terms of duty cycle has described by the following Eqn. (3).

$$\Rightarrow V_o = (V_{piezo} + V_{c1}) \frac{D}{(1-D)} = 0 \quad (4)$$

The abbreviation of D is the duty cycle; V_{out} is the output voltage and V_{in} is the input voltage. The meaning of L is the inductance; From the equation, it is shown that output voltage is equal to sum of piezo voltage and capacitor $c1$ storage voltage. Therefore, from the Eqn. (4), it is shown that the capacitor storage voltage added to the piezoelectric input voltage.

SIMULATION RESULTS AND DISCUSSION

A sinusoidal AC voltage source which can produce 540mV amplitude and 100 Hz of vibration frequency has been considered for verification of the presented model. This design has been simulated in Pspice (V16.5). The obtained result has been shown in Figure-7 & 8 to verify the design and the result also compared with the very closely related works. The nominal load resistance is 1k and duty cycle of the design is very low, 10%. As a result, that model has been working as a discontinuous conduction mode which reduce the switching losses. The targeted output voltage is 3.4V which has been shown in Figure-7. From the simulation result, it is observed that output power is 57mW that has been shown in Figure-8, that is almost six times higher power compared to split capacitor based converter [6].

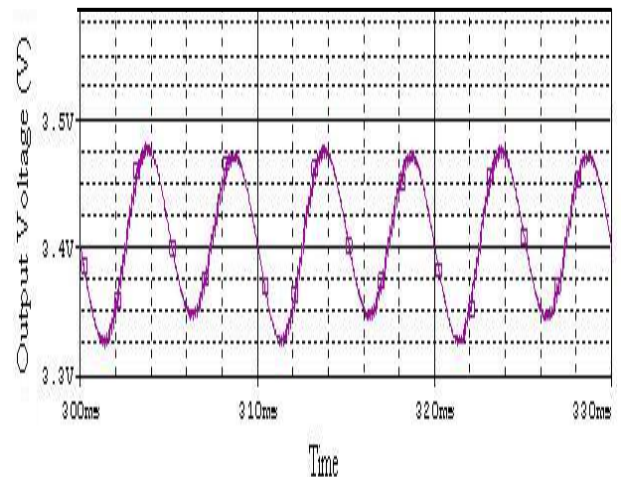

Figure-7. Output voltage vs time.

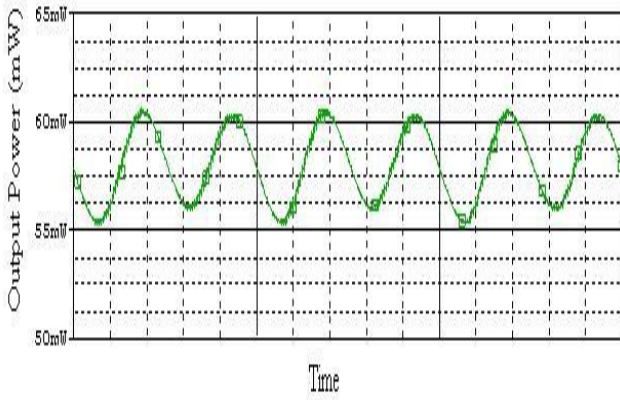

Figure-8. Output power vs time.

Table-2. Performance analysis of micro energy harvesting system.

Harvesting Model	Input voltage (V _i)	Output voltage (V _o)	Power (P _o)
Dual polarity Boost Converter [1]	0.3V AC	3.3V	50mW
Split Capacitor topology [6]	0.2V-0.8V AC	3.3V	10mW
Boost converter in Feedforward control [7]	0.4V-1.4V DC	3.3V	35mW
Proposed design	0.54V	3.4V	57mW

The significancy of this topology is that a single capacitor (C) has been used for storing charge to fulfil the future load demand. This charged has been stored both in positive and negative half cycle. Therefore, it is mentioned that it can overcome the dual polarity boost converter design problems [1] especially reducing the number of capacitor requirement. Also it can reduce the ripple voltage and solve the polarity sensing problem as one diode and one capacitor has been used.

The crucial feature the of proposed design is single stage AC-DC converter which output voltage has been boosted up to the demanded voltage for powering the load circuit such as WSN. This system overcomes the bridge rectification by using only one diode and one capacitor. This capacitor C1 is used by replacing a diode which has an important impact on this design as it helps to achieve series and parallel resonance.

CONCLUSION

The developed design consists of a voltage doubler and two buck boost converters in parallel. The significance of this design is that, the negative gain of the buck boost converter is utilized by boosting up the negative half cycle of the input and then adding with the positive half cycle of the other buck boost converter voltage. The design has been successfully simulated to verify the converter performance and it is noted that its output power is better compared to other conventional designs.

REFERENCES

- [1] Mitcheson, P. D., Green, T. C., and Yeatman, E. M. (2007). Power processing circuits for electromagnetic, electrostatic and piezoelectric inertial energy scavengers. *Microsystem Technologies*, 13(11-12), 1629-1635.
- [2] Kim, H., Kim, J.-H., and Kim, J. (2011). A review of piezoelectric energy harvesting based on vibration. *International Journal of Precision Engineering and Manufacturing*, 12(6), 1129-1141.
- [3] Fleming, A. J., Behrens, S., and Moheimani, S. O. R. (2003). Reducing the inductance requirements of piezoelectric shunt damping systems. *Smart Materials and Structures*, 12 (1), 57.
- [4] B. Calhoun, D. Daly, N. Verma, D. Finchelstein, D. Wentzloff, A.Wang, S.-H.Cho, and A. Chandrakasan, 2005, "Design Considerations for Ultra-low Energy Wireless Micro-sensor Nodes," *IEEE Trans. Computers.*, vol. 54(6), pp. 727-740.
- [5] Kumar K., S.V. Sivanagaraju, Rajasekharachari K. (2013) "Single Stage AC-DC Step up Converter using Boost and Buck-Boost Converters. *International Journal of Advanced Research in Electrical, Electronics and Instrumentation Engineering* Vol. 2(9), pp. 4245-4252.
- [6] Dayal, R., Dwari, S., and Parsa, L. (2011). Design and implementation of a direct AC-DC boost converter for low-voltage energy harvesting. *Industrial Electronics, IEEE Transactions on*, 58 (6), pp. 2387-2396.
- [7] Cao, X., Chiang, W. J., King, Y. C., & Lee, Y. K. (2007). Electromagnetic energy harvesting circuit with feedforward and feedback DC-DC PWM boost converter for vibration power generator system. *Power Electronics, IEEE Transactions on*, 22(2), 679-685.