

# Fundamentals of shooting with digital video cameras

---

Vicente Rodríguez Ortega & Francisco Utray Delgado  
Universidad Carlos III de Madrid  
Grupo de investigación TECMERIN  
[vrortega@hum.uc3m.es](mailto:vrortega@hum.uc3m.es)  
[futrayer@hum.uc3m.es](mailto:futrayer@hum.uc3m.es)

Introduction .....	2
Exposure control (iris) .....	2
Determining exposure through the use of zebra stripes .....	3
White Balance .....	4
Shutter Speed.....	5
Focus .....	5
Audio Levels .....	6
Annex 1: shooting with a Mini DV camera: Sony DSR-PDX10P.....	7

## **Introduction**

There are 5 variables we always have to take into account when preparing to shoot with a digital video camera. Although all cameras have automatic adjustments that create good quality images and audio, it is essential to use manual adjustments so that, at all times, we have full control of the images and sounds we obtain when shooting a video project.

1. Exposure
2. White Balance
3. Focus
4. Shutter Speed
5. Audio levels

## **Exposure control (iris)**

Aperture is the opening through which light travels. In order to properly prepare to shoot, you need to determine your camera's aperture—that is, how much is the camera's diaphragm going to be open to let the light come in. By opening the diaphragm more or less, you determine your exposure.

Exposure is thus the total amount of light you allow into the camera's lens.

In the first shot below, the camera automatically adjusts the exposure for the strong backlight. This is not what we need, since the face of the subject remains quite dark. In other words, the camera is adjusting to the light outside and leaving the character or subject in darkness. To properly shoot this scene, we need to follow these steps:

1. Set the camera to manual.
2. Open the iris until the subject is exposed correctly. Consequently, the background will be very bright. It's a sacrifice you need to make in these circumstances since the rule of thumb is that you need to achieve the best possible exposure for the part of the frame where your focus of action/interest is.

In the second shot, after setting the camera to manual, we have opened the iris and the subject is correctly exposed.

Keep in mind that even if your shot is overexposed outside, your spectator or viewer will concentrate where the focus of the shot and story is (in this case, the subject).



Images courtesy of Media College<sup>1</sup>

## Determining exposure through the use of zebra stripes

Overexposure is a major problem. Similarly to underexposing, you typically lose detail and this is something you want to avoid at all costs. Postproduction software allows you to apply a variety of filters and image adjustments and improve the detail of your image but this is far from ideal. The first rule is that the camera operator needs to try to get the best image possible regardless of what the editing can fix.

In addition, the digital camera's viewfinders are not often reliable in terms of color and exposure. You can trust them to a certain extent but do not hesitate to use other tools to improve your control over the image. Zebra stripes allow us to have such control.

To use them:

1. Turn zebra stripes on.
2. See what parts of the images are overexposed: the zebra stripes will mark them.
3. You can then change your exposure. As you do so, the amount and location of zebra stripes will vary progressively.
4. Choosing the right exposure is always an act of balance. Typically, there will be parts of your frame that will receive more light than others. You may want to have a balance or, conversely, you may attempt to create a low-key lighting situation with lots of contrast. It is always an artistic choice that helps to build the content and ideas you want to express. Remember, however, that having very "burnt" (overexposed) images does not normally help your film or video.

---

<sup>1</sup> <http://www.mediacollege.com>

*if you're exposing for skin tone=70% is often the preferred indicator*



*if you're exposing for maximum white point, 100% is the preferred indicator.*



Image Courtesy of The Dvshow

## White Balance

- To establish the “white balance” in a scene, first, use a white sheet of paper and zoom all the way in with the camera.
- Adjust exposure and focus.
- Activate the manual white balance setting in the camera.
- The camera will adapt to the color temperature in each specific scene





Images courtesy of Media College<sup>2</sup>

## Shutter Speed

Shutter speed is the term used for exposure time—that is, the amount of time the camera's shutter is open.

The shutter opens and closes once for each frame; that is, 25 times per second for PAL and 30 times per second for NTSC. Thus, if a camera has its shutter set to 1/60, each frame will be exposed for 1/60 second. If the speed is increased to 1/120, each frame will be exposed for 1/120 of a second.

Typically, you will use shutter speeds of 1/60 or faster. This is because slower shutter speeds will get you blurry images. Motion blur occurs when the subject moves within the frame while the shutter remains open. The less time the shutter is open (the faster the shutter speed), the less movement will take place and your images will be sharper.

The three shots below show ad car as it travels past a stationary camera at 100 km/hr. With the shutter off, motion blur is most pronounced. As the shutter speed is increased, the image becomes sharper.



Shutter Off



1/120 second



1/500 second

## Focus

All cameras have an auto-focus feature. However, the focus is a stylistic and dramatic choice and the director of photography must always have full control of the subjects and objects that

---

<sup>2</sup> <http://www.mediacollege.com>

are in focus. It is likely that in the middle of a shot, for example, you may want to change the focus of attention of the spectator changing the focus.

Remember that most digital cameras have a zoom lens, which has variable focal length--that is, zoomed out all the way it has longer focal length, having thus, less depth of field, and zoomed in it has shorter length, having more depth of field.

To focus on a particular object or subject:

1. Zoom all the way in.
2. Adjust the focus ring until the subject or object is in full focus.
3. When you zoom out, the focus you have determined will remain in place until you change it. If you zoom in again, the subject or object you focus on will still be in focus.

## **Audio Levels**

Modern cameras have good in-camera microphones that, in controlled shooting environments, generate good quality audio. However, these in-camera microphones do not have the capacity to capture sound with the same quality as professional audio equipment. In addition, shooting on location adds another layer of difficulty since sounds may emanate from anywhere, making more difficult the recording of good sound.

Generally speaking, professional video makers attach a variety of microphones to their cameras to have the flexibility to capture sound in a diverse set of environments. It is important to consider that, although editing equipment allows video makers to change a variety of sound qualities and even clean some unwanted audio frequencies, if the recorded sound has poor quality, there is little one can do in postproduction. Consequently, the first and most important rule in regard to sound is to spend time recording the best quality sound possible.

Sound recordists use channel 1 to record the most important sounds and channel 2 to record ambience sound. Each channel can be controlled separately and their levels should be set in separate tracks. Using a microphone attached to a boom or a wireless microphone (in an interview for example), sound recordists always prioritize the source of audio they want to privilege in terms of storytelling.

## Annex 1: shooting with a Mini DV camera: Sony DSR-PDX10P

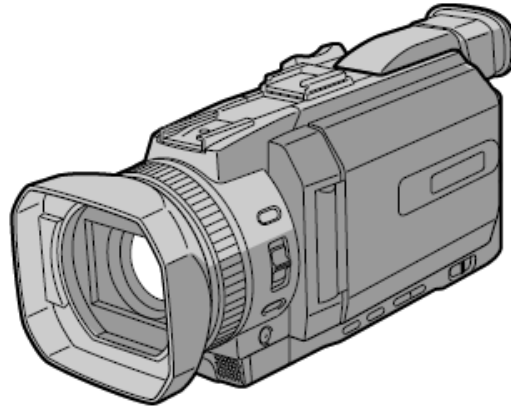

It is always preferable to use manual adjustments: this allows us to control with more accuracy the image and sound settings.

To start with, we must deactivate the Autolock setting in the camera. This first step must always be done in preparation to use manual adjustments.

Manual adjustments allow us to control:

1. **Exposure:** it controls the aperture-- that is, the amount of light the camera's diaphragm allows to come in.
2. **White balance.** It controls the chromatic balance of the image, adjusting it to the color temperature in each specific location when the shooting process occurs.
3. **Shutter speed:** It controls the time of exposure

### SELECCIÓN AUTOLOCK

To change your camera settings, set the AUTOLOCK to position B, otherwise the camera will not allow you to change white balance, exposure and shutter speed.

If you change your settings and you want to keep them, preventing any accidental change, set them to C or HOLD

## EXPOSURE ADJUSTMENT

- (1) Change the AUTOLOCK selector to the middle position (remember the camera must be set to CAMERA to have all the proper options active).
- (2) Push the exposure button.
- (3) Using the SEL/PUSH EXEC wheel, adjust the exposure by turning it in either direction.

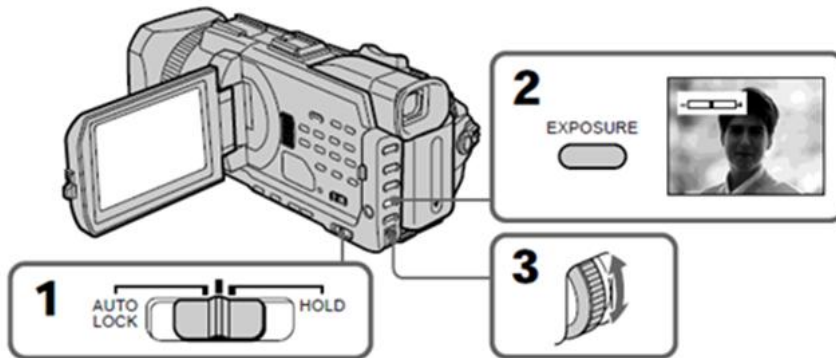

## SHOOTING WITH ZEBRA STRIPES

Use the Zebra stripes selector as a guide to determine what parts of your frame are overexposed.

You may set to 70 or 100. If you choose the first option, zebra stripes will show in the parts of your shot where your IRE is approximately 70. The 100 setting functions exactly the same.

Note: A value of 100 IRE was originally defined to be the range from black to white in a video signal.

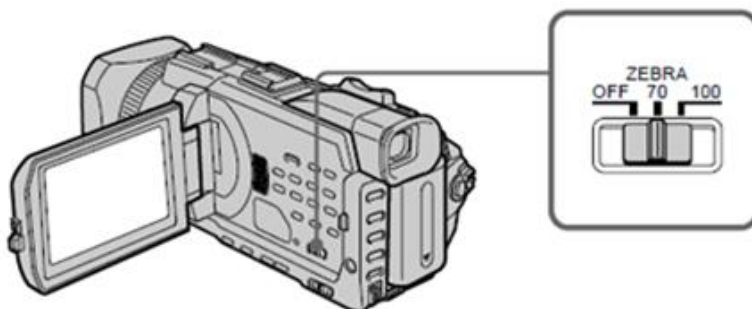



## WHITE BALANCE

To adjust the white balance

- (1) Set AUTOLOCK selector to the middle position.
- (2) Push white balance.
- (3) Turn the SEL/ PUSH EXEC wheel to select manual white balance.

Then, using a white sheet of paper, zoom all the way in and press the PUSH/SEL EXEC wheel. The manual white balance icon will flicker for a few second. When it stops, you will have determined your new white balance.

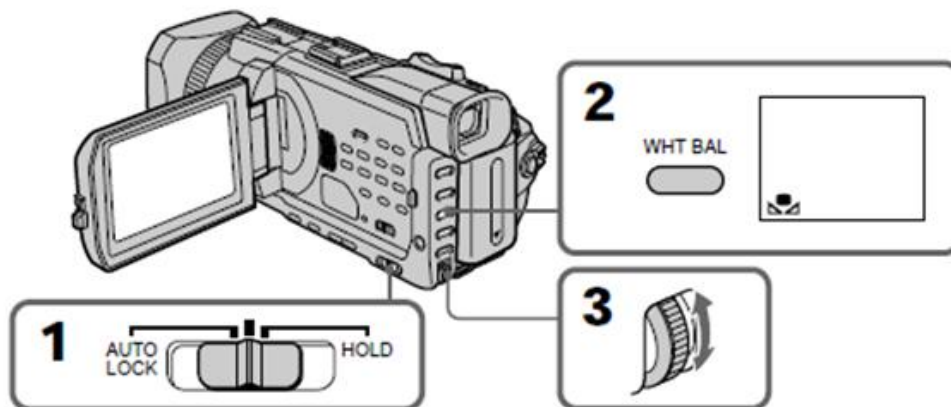

## SHUTTER SPEED

- (1) Set the AUTOLOCK button to the middle position.
- (2) Press SHUTTER SPEED.
- (3) Turn the SEL/PUSH EXEC wheel to either side to choose your shutter speed.

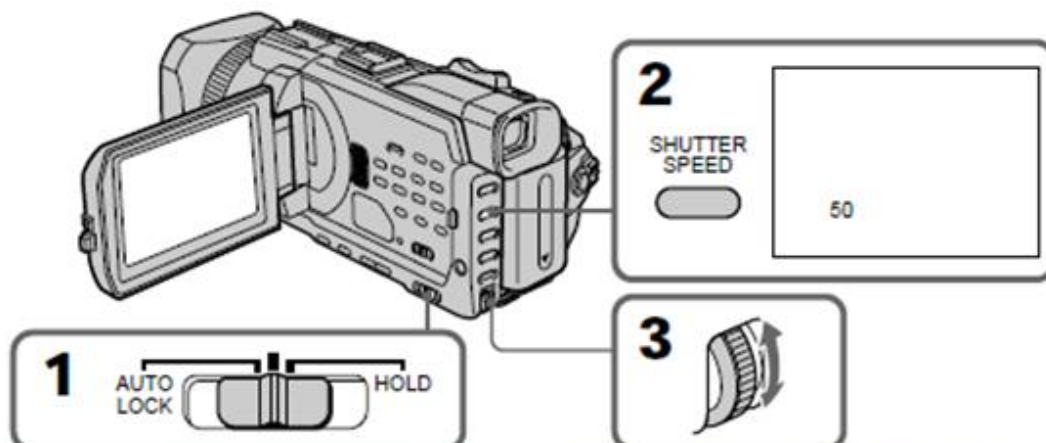

## MANUAL FOCUS

- (1) Set the focus button to MAN
- (2) Turn the focus ring in either direction to determine your focus.

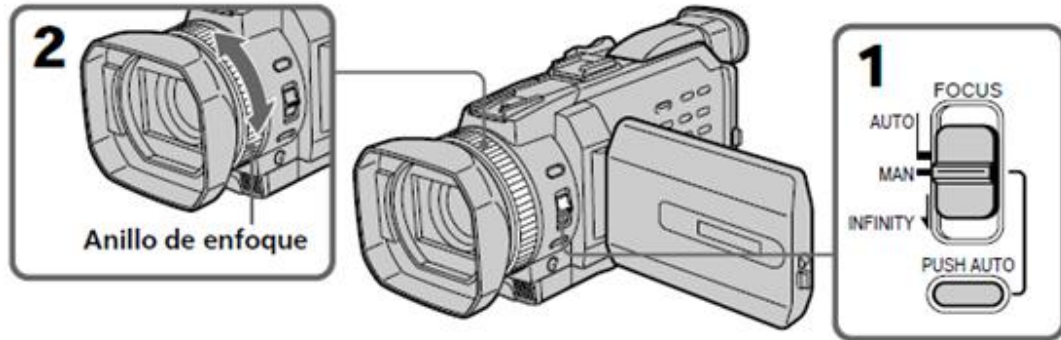

## SOUND ADJUSTMENTS WITH THE SONY DSR-PDX10P

Adjust in the menu the sampling frequency of your audio to 32 K [TAPE\_SET/audio mode].

When we create a new project in PREMIERE we will also have to adjust the sampling frequency to 32 K.

Activate in the camera menu the setting to manually control the audio levels [XLR set].

Use input 1 for track 1 (where you record the most important sound bites). Manually adjust the recording levels.

Use input 2 for the in-camera microphone. When the soundscape varies ostensibly, set in automatic the audio levels in channel 2.

In the connection panel for inputs 1 and 2 of the camera, select [MIC] in [Input Level] for both channels.

Activate phantom power +48 for the types of microphones that need this type of power.

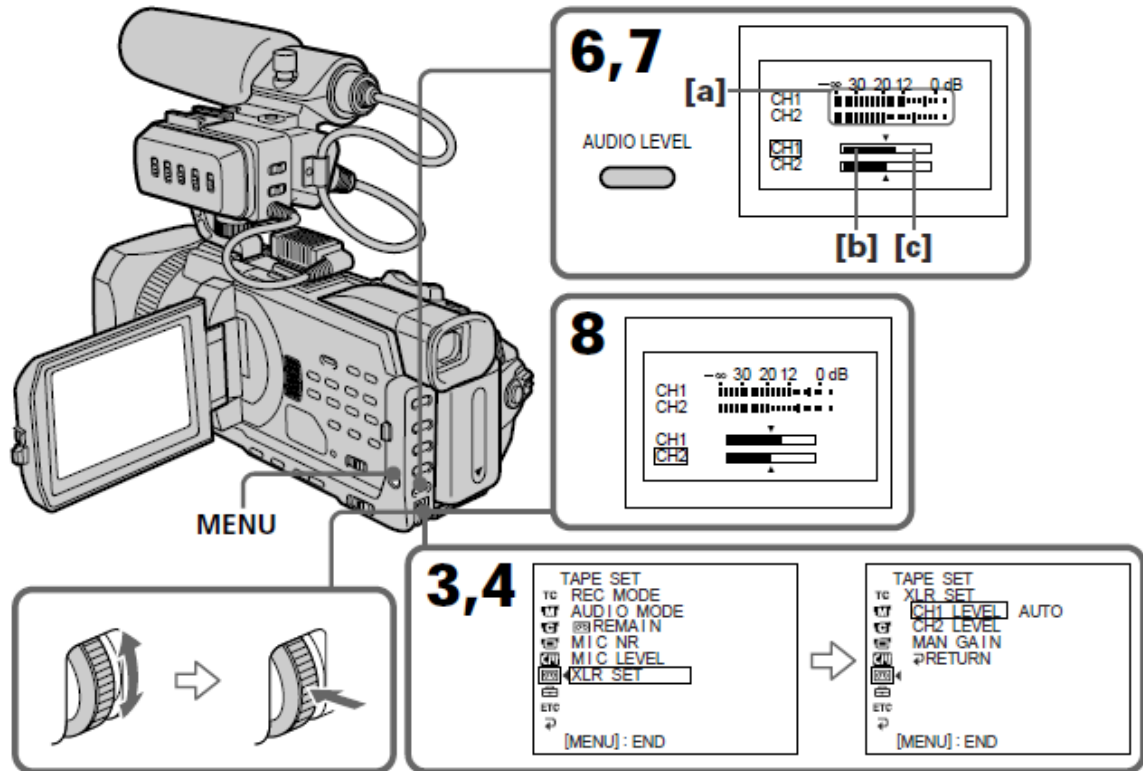

## AUDIO SETTINGS

First, connect your microphones in Input 1 and 2 on the camera's side.

- (3) Set XLR set to M in the camera's menu (remember the camera must be set to VCR or Camera).
- (4) Turn the SEL/ PUSH EXEC wheel to choose the right setting and push the wheel.
- (5) Turn the SEL/ PUSH EXEC wheel to choose the right setting and push the wheel.
- (6) Push Audio levels to check the recording levels before shooting.
- (7) Turn the SEL/ PUSH EXEC wheel to choose the right setting for channel 1. Push the wheel. The cursor will move to channel 2.
- (8) Repeat the same operations with channel 2.