

Available online at www.sciencedirect.com**ScienceDirect**

Energy Procedia 65 (2015) 204 – 214

Energy

Procedia

Conference and Exhibition Indonesia - New, Renewable Energy and Energy Conservation
(The 3rd Indo-EBTKE ConEx 2014)

Simulation Study for Economic Analysis of Biogas Production from Agricultural Biomass

Maizirwan Mel^{a*}, Ariff Syamin Hisham Yong^a, Avicenna^a, Sany Izan Ihsan^b,
Roy Hendroko Setyobudi^{c,d}

^aDepartment of Biotechnology Engineering, ^bDepartment of Mechanical Engineering

Faculty of Engineering, International Islamic University Malaysia (IIUM), Gombak, 50728 Kuala Lumpur, Malaysia

^cMa Chung Research Center for Photosynthetic Pigments, Villa Puncak Tidar N-01 Malang 65151, East Java, Indonesia

^dIndonesian Association of Bioenergy Scientist and Technologist. BPPT Building II, 22nd Floor Jl. MH. Thamrin No. 8 Jakarta 10340

Abstract

A process of anaerobic digestion of agricultural biomass was simulated by SuperPro Designer software v 8.5 to analyze the cost of production. The simulated project used fruits and vegetable wastes as a feedstock. The concentration of methane produced is 55 % (v/v) from a total of 936.8 m³ · h⁻¹ biogas and after purification, the concentration of methane is upgraded up to 95 % (v/v). The system was designed to treat the agricultural waste, and was able to reduce more than 60 % of the initial COD (chemical oxygen demand). From the study, economic analysis shows that the profit margin is achieved at 11 % and the rate of return of investment is at 12 % which gives a payback period of 8.2 years.

© 2015 The Authors. Published by Elsevier Ltd. This is an open access article under the CC BY-NC-ND license (<http://creativecommons.org/licenses/by-nc-nd/4.0/>).

Peer-review under responsibility of the Scientific Committee of EBTKE ConEx 2014

Keywords: biogas; biomass; economic analysis; simulation

Nomenclature

COD	chemical oxygen demand	g	gram	h	hour
HRT	hydraulic retention time	IRR	internal rate of return	kW	kilo Watt
kg	kilogram	L	litre	min	minute
m³	meter cubic	NPV	net present value	OLR	Organic loading rate
ROI	return of investment	VFA	volatile fatty acids	d	day
v/v	percentage volume/volume	w/w	percentage weight/weight	yr	year

* Corresponding author. Tel.: +60 361 964 566; fax: +60 361 964 442.

E-mail address: maizirwan@iium.edu.my

1. Introduction

1.1. Biogas properties

Biogas is produced when organic matter is digested by certain microorganisms in the absence of oxygen to become biogas which mainly consists of methane, carbon dioxide and other inertly available gases. Biogas production has four key components that are feedstock, microorganisms, environmental control and reactor configuration or technological design. There are three major sources of biogas feedstock for biogas production here in Malaysia which are from agroindustrial waste, farm waste and municipal solid waste [1].

The chemical composition of the biogas produced depends on the substrate that is being used as feed and the feeding rate of the digester. If glucose and starch or cellulose is being used as the primary composition of the feed, then the biogas produced would have an equal amount of methane and carbon dioxide with a ratio of 50 : 50 [2]. However, if the fat content is high then the methane portion of the biogas would be higher than carbon dioxide [3]. Other gases that make up biogas are hydrogen sulphide, water vapour and hydrogen. Presence of hydrogen sulphide and water vapour makes biogas very corrosive and can damage equipments such as storage tanks and gas turbine. As for that reason, purification process are needed to remove hydrogen sulphide, water vapour and carbon dioxide. Methane is what makes the biogas combustible and generally makes up 55 % to 80 % of biogas. Methane is a colourless and odourless gas with a boiling point of $-162\text{ }^{\circ}\text{C}$ and it burns with a blue flame. Methane is also the main constituent of natural gas which is around 77 % to 90 %.

1.2. Natural conversion of organic waste

Agricultural waste that contains high organic matter if not managed properly will cause detrimental damage to the environment. Anaerobic digestion of these waste will not only reduce its organic strength but also convert them into other products that may be useful such as biogas. These waste may also be converted into high nitrogen content fertilizers after naturally being processed in an anaerobic digester.

1.3. Renewable energy source

Methane is the key component that makes biogas combustible. This property is vital in making biogas capable of replacing other energy sources such as wood, coal, kerosene, plant residues and to a certain extent, coal and natural gas since the current energy supply is highly dependent on these sources [4]. Small biogas production units can support lighting and be used as fuel for cooking, while larger biogas plants can generate electricity and supply them to the national grid. For an example one cubic meter of biogas can produce (6 to 7) h of 60 Watt energy, can cook three meals, generates 1.25 kW electricity, and can run 1 hp motor for 2 h.

1.4. Environmental benefits

Biogas has the potential to replace fossil fuels as the primary energy source of the world. This will save the earth's precious resources and expands the lifetime of oil and natural gas reserves of the world. Since biogas is a renewable energy, there is no worry of it running out. The use biogas instead of fossil fuels will also dramatically reduce the emissions of greenhouse gases. Biogas plants are designed to trap greenhouse gases such as methane and later use it as a fuel. Even though the combustion of biogas releases carbon dioxide, since methane (CH_4) contains only one carbon, it produces less carbon emission as compared to the carbon emission of combusting long-chain hydrocarbons such as fossil fuels. Thus, the carbon cycle of using biogas is closed quicker than burning of fossil fuels through uptake of carbon from the atmosphere by photosynthetic activity. The application of biogas will also improve water quality especially in rivers and waterways as the water out of the biogas plant is the reduced organic strength effluent.

1.5. Waste reduction

The biological treatment of waste is very useful in terms of providing a cost efficient way to reduce the amount of waste. Agricultural wastes may take up a lot space especially in countries like Malaysia where agricultural production are one of the largest exports of the country. Biogas plant technology may provide a solution to store and treat these waste to an acceptable level of organic strength before discharging to the environment.

1.6. Unit processes

The anaerobic digestion of organic matter consist of three main phases which are hydrolysis, acidogenesis and methanogenesis. It should be noted as well that acetogenesis also take place in the digestion, just not as critical as the three main processes. In each of the processes, specific group of microorganism are involved. These organism are commensal in relation, which means there are in need of each other for the breaking down and conversion of the product of the previous microbe.

The first process is hydrolysis. Hydrolysis is the process of breaking down large and complex feedstock molecules into smaller and simpler structures. This process is done by facultative aerobic bacteria which uses oxygen in the feedstock and water and the function equally well both in the presence and absence of oxygen. Hydrolysis usually takes place at temperature around 37 °C. During hydrolysis, polymers such as carbohydrates, lipids, protein and nucleic acids are broken down into mono and oligomers like glucose, glycerol, pridines and purines. Hydrolytic microorganisms excrete hydrolytic enzymes, converting biopolymers into simpler and soluble compounds.

The second step of the process is acidogenesis. This process is basically similar to fermentation and even uses similar types of microbes. The acidogenic bacteria converts the monomers and oligomers into acetic acid, hydrogen and carbon dioxide. Another respiration pathway is the conversion of simple sugars, amino acids and fatty acids into volatile fatty acids and alcohols which will later on undergo acetogenesis and converted into acetic acid. Volatile fatty acids (VFA) such as butyric acid and propionic as well as acetic acid are methanogenic substrates.

After acidogenesis, acetogenesis takes place, where products from acidogenesis which cannot be directly converted into methane by methanogenic bacterias will be converted into methanogenic substrates. VFA and alcohols are oxidized to become acetate, hydrogen and carbon dioxide. Along with acidogenesis, the production of hydrogen becomes high and this will cause the partial pressure of hydrogen to increase. Hydrogen can be considered as a waste product of acetogenesis and it inhibits the metabolism of acetogenic bacteria. During methanogenesis, hydrogen is converted into methane and that reduces partial pressure of hydrogen and no longer inhibits the acetogenic process. Acetogenesis and methanogenesis usually runs parallel as symbiosis of one another.

Finally, methanogenesis converts methanogenic substrates into methane via two pathways. First, acetic acid is converted into methane and carbon dioxide. The other pathway is conversion of hydrogen together with carbon dioxide producing methane and water. Methanogenesis is the most critical step in the entire anaerobic digestion process as it is the slowest biochemical reaction of the process. Not to mention, the microorganisms involved are very sensitive thus its performance is severely influenced by operating conditions. Temperature, pH, feeding rate and composition of feedstock are just some of the factors that must be monitored closely. Organic overloading, pH fluctuations and oxygen entry may terminate the generation of methane all together.

1.7. Advanced technological designs

More advanced technological designs are required to facilitate the needs and demands of corporations. These technological design are an engineering feat in themselves and the complexity of some of the technologies requires more research especially for a developing country like Malaysia.

One of the advanced design of biogas production is the upflow anaerobic sludge bed. Another form of this design is the expanded granular sludge bed. The concept of this design is that the feed is flowed from the bottom of the reactor. The feed which is full of organic matter will go through a bed of immobilized bacterias and when it is overflow at the top of the reactor the organic matter are already degraded. What is left is the treated waste and safe for discharge. This design very suitable for wastewater treatment and treatment of liquid form of waste.

Another advanced design of biogas plant is the two-stage anaerobic digester. The conventional anaerobic bioreactor is a single reactor where the feed undergo all the biochemical processes in one go albeit for hydrolysis if there is any pre-treatment to the substrate. A two stage anaerobic digester intends to separate the acidogenesis and methanogenesis processes to obtain higher yield of methane. Since methanogenesis takes a longer time, the retention time for the first reactor which facilitates acidogenesis will be lower than the second reactor. When more acids are formed and feed into the methane reactor, more methane will be produced within the condition that the pH of the methane reactor is maintained. However, this design system has its flaw. First, the acidogenic and methanogenic bacteria are commensally interacted. It means that one is needed to facilitate the biochemical reaction of the other. Another flaw is, the control method of the methanogenic substrate are yet to be refined because excessive VFA will disrupt the methanogenic process and production of VFA are biological of nature and only through kinetics it is possible for the prediction of the production of VFA.

Another technological aspect that should be looked into is the purification of biogas. In today's industries, there are various ways and methods to purify biogas by removing both hydrogen sulfide (H_2S) and carbon dioxide CO_2 , thus having high purity of methane. As of now, there is no clear best technology and the cost between different technologies are fairly similar [5]. The selection of the best technology for biogas upgrading depends on gas flowrate, method of utilisation, market demand and much more [6]. The most widely used technologies in upgrading biogas are water scrubbing, chemical scrubbing, membrane and pressure swing adsorption.

1.8. Cost analysis

There are several important questions that must be answered before any investment is put into establishing a biogas facility: i) is it economically viable? ii) What is the duration for the investment to turn into profit? iii) What are the environmental risks involved? iv) Will the market be saturated for a foreseeable future? v) Are the cost involved stable for a duration of time?

These question can be answered through some mathematical model. Energy harvested from anaerobic digestion has expanded tremendously in Europe due to the new electricity tariff based on agricultural waste energy harvesting. At a rate of 35 Euro cents per kWh, it is one of the highest rates to be paid for anaerobic digestion power plant as compared to Malaysia which is at RM 0.32 per kWh for a similar technological facility. For example, a biogas plant treating POME in Palong, Negeri Sembilan invested by Cenergi Corporation cost the company RM 20 Million, holding the contract for 15 yr. The return of investment will only be after 7 yr and only 8 yr in profit.

2. Material and method

The simulation was performed by using SuperPro Designer Software v 8.5 (Intelligent Inc.). After putting all the input data into the software, the software automatically calculates its own mass and energy balances, the volume of each unit process, the amount of heating agent needed, the power requirements, and the cost analysis. The composition of raw materials must be defined firstly before simulated. The composition set was based on literature review of solid waste composition in Malaysia. The unit processes were chosen and placed in sequence and connected by stream lines. The complete flow sheet diagram can be seen from Figure 1.

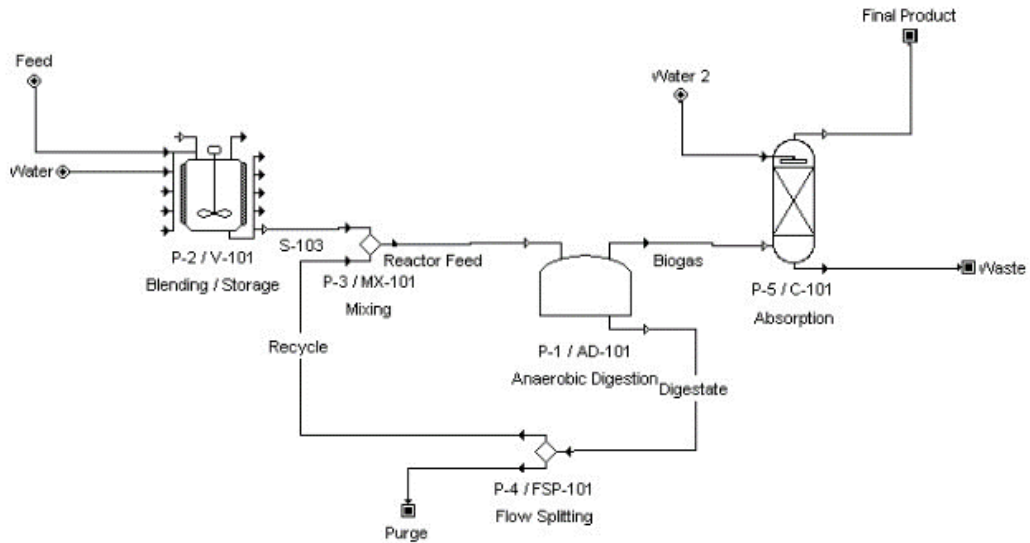

Fig. 1. Complete flow stream of the anaerobic digestion process.

The streams were defined by the material composition that were set on each streams. The chemical reactions stoichiometry were set in the anaerobic digester operation data window to let the software performed the mass and energy balances computation.

2.1. Chemical reactions establishment

The stoichiometry of each reaction was adapted from anaerobic digestion mathematical modelling by Yu et. al [7]. This stoichiometry equations were the first input data for the reactor initiation.

2.2. Process flowsheet

The number of unit operations were minimised to lower the cost of plant. Only three major unit process that is required, which were the storage, anaerobic digester and the water-scrubbing column. The storage unit is to store the raw materials that is the fruits and vegetable waste. The anaerobic digester is where the waste are being biologically degraded to produce methane. The water-scrubbing unit is to purify the biogas to achieve purity greater 97 %. The operating conditions were determined based upon the decision of which operating conditions suited best with the costs, location and yield of product.

2.3. Storage tank properties

The storage tank act as both storage and mixing tank. The fruit and vegetable wastes were assumed to be in dry mass, therefore water is supplied and mixed in the tank to dilute the waste. The holding time of the waste in the storage tank is one day with continuous mixing and stirring. That required the tank to be 47.8 m³ and the tank was set to be made out of concrete, except for the equipments and mechanical parts that are attached to it. Table 1 summarizes the operating conditions and properties of the storage and blending tank.

Table 1. Properties and operating conditions for storage and blending unit

Operating Parameter	Value
Volume	47.8 m ³
Holding time	24 h
Total mass handled	48 000 kg
Power requirements (blending)	0.49 kW
Materials of construction	Concrete

2.4. Anaerobic digester

The anaerobic digester is where all the chemical reactions takes place and where the biogas is produced. It was decided that mesophilic microorganism are deemed most suitable due to its availability in Malaysia and its yield of methane. In line with that decision, the operating conditions must suit the mesophilic microorganism. The operating temperature is set at 35 °C and pH 7. The hydraulic retention is set to be 25 d. The operating conditions and properties for the digester is summarized in Table 2.

Table 2. Properties and operating conditions for anaerobic digester

Operating Parameter	Value
Volume	2465.28 m ³
Holding time	25 d
Total mass handled	2 503 704 kg
Power requirements (pumping)	24.65 kW
Materials of construction	Concrete

2.5. Absorption column

The operating condition of the column was set at 25 °C which was the temperature of the absorbing water, eventhough the temperature of incoming gas was 35 °C. Pressure was set at 1 atm (101 325 Pa) and the process was isobaric and adiabatic. Table 3 shows a summary of the operating condition and initiation of the absorption column.

Table 3. Properties and operating conditions of absorption column

Operating Parameter	Value
Volume	643.38 m ³
Pressure drop	1.009 bar ¹⁾
Materials of construction	Carbon steel

¹⁾1 bar = 100 000 Pa

2.6. Cost analysis

Economic analysis was performed based on the altered database to suit the conditions desired. Table 4 shows the adjusted costs for the operation and startup of the plant that was required by the software to perform the economic analysis.

Table 4. Cost of initiation and operation data

Cost	Value
Water	RM 0.00053 / m ³
Electricity	RM 0.337 / kWh
Labor	RM 50 / h
Revenue	RM 5 / kg CH ₄
Waste (total cost)	RM 1 062 335 / yr
Materials	RM 0.009375 / kg
Steam (heating agent)	RM 12 / ton ¹⁾

¹⁾1 ton = 10³ kg RM = MYR = Malaysian Ringgit (1 MYR.~ USD 0,31. Oct 13,2014)

3. Discussion

3.1. Mass and energy balances

Energy balance is represented in the amount of steam that is needed to heat up a certain equipment which in this case, only the anaerobic digester requires heating element to increase the temperature from 25 °C to 35 °C.

The feed was set at 1 000 kg · h⁻¹ on dry mass basis. This was decided upon the estimation of availability of specifically, fruits and vegetable wastes. This feeding rate can be adjusted to the desired amount at any time, given that the composition of the feed is known. The composition was set at 55 % carbohydrates, 26 % proteins and 19 % fats to maximise the production of biogas. The composition of raw materials in feed stream, the total materials after recycle, the product after leaving the digester, and the composition of total digestate produced are provided in Table 5, Table 6, Table 7, and Table 8, respectively.

Table 5. Composition of raw materials in feed stream

Component	Flow rate (kg · h ⁻¹)	Mass composition (%)	Concentration (g · L ⁻¹)
Carbohydrates	550	55	557.05
Fats	190	19	192.44
Proteins	260	26	263.33

Total mass is 1 000 kg · h⁻¹ on dry mass basis at temperature of 25 °C and pressure of 1.013 bar

Table 6. Composition of total materials entering reactor after recycle

Component	Flow rate (kg · h ⁻¹)	Mass composition (%)	Concentration (g · L ⁻¹)
Ammonia	54.35	1.3	0.65
Biomass	377.15	9.04	4.5
Carbohydrates	550	13.18	6.56
Fats	190	4.55	2.27
Proteins	260	6.23	3.1
Water	2 741.34	65.69	32.72

Total mass flow is 4 172.84 kg · h⁻¹ (equivalent to 83.73 m³ · h⁻¹) at temperature of 31.14 °C and pressure of 1.013 bar

Table 7. Composition of product leaving the digester

Component	Flow rate (kg · h ⁻¹)	Mass Composition (%)	Concentration (g · L ⁻¹)
Carbon dioxide	728.62	68.12	0.78

Hydrogen sulfide	23.2	2.17	0.02
Methane	317.82	29.71	0.34

Total mass flow rate is 1 069.64 kg · h⁻¹ (equivalent to 936.76 m³ · h⁻¹) at temperature of 35 °C and pressure of 1.013 bar

Table 8. Composition of total digestate produced

Component	Flow rate (kg · h ⁻¹)	Mass composition (%)	Concentration (g · L ⁻¹)
Ammonia	77.64	2.5	0.66
Biomass	538.78	17.36	4.55
Water	2 487.69	80.14	21.02

Total mass flow rate is 1 069.64 kg · h⁻¹ (equivalent to 936.76 m³ · h⁻¹) at temperature of 35 °C and pressure of 1.013 bar

In this model, the maximum yield of biogas can only be obtained from this feed composition. Different feed composition will cause the recycle and purging of unreacted intermediate products such as propionic acid, butyric acid, acetic acid, and hydrogen. In real life application, by literature the composition of fruit and vegetable wastes does not tally with this model. The composition of waste contains more carbohydrates in the form of lignocellulose and less fats and proteins. However, the feed composition of this model can be achieved by adding specific fruit and vegetable wastes such as adding corn, sunflower or soybean wastes to increase proteins and fats composition. Table 9 shows the composition of corn waste [3] in the form of distiller grains that can increase the concentration of proteins and fats in the substrate.

Table 9. Composition of corn waste

Component (%)	Corn Grain	Distillers Grain
Crude protein	9.4	30
Neutral detergent fiber	9.5	40
Starch	70	4
Crude fat	4.2	12
Phosphorus	0.3	0.8

The biogas produced, as shown in Table 7 is 936.76 m³ · h⁻¹ from a feed rate of 83.793 m³ · h⁻¹ after recycle. The product is produced about 10 times more than the feed rate which is comparable to other studies which stated that biogas production may be 10 to 30 times of substrate [8]. The methane produced is 29.71 % by mass basis. If that figure is converted in volume basis, the methane produced is 55.6 % (v/v) which is consistent with the findings of other researches [4].

Since the feed was estimated on dry mass basis, water is needed to dilute and liquify the waste for ease of flow. The wastes were diluted with water at a ratio of 1 : 1 because large inoculation volumes can ensure high microbial performance, low risk of inhibition and low risk for overloading [9]. The amount of water was adjusted to an optimum amount to achieve the best yield of product. Less water provided will cause intermediate products such as butyric acid and propionic acid to be unreacted and wasted. Excess water provided will incur more operational cost, thus, 1 000 kg · h⁻¹ is the optimised amount of water needed. Though more water is needed for the initiation of the plant since the chemical oxygen demand (COD) at 65,554 mg · L⁻¹, is too high for the microorganisms to breakdown [10]. Only after the 25 d retention time, the recycle stream will further dilute the waste for the COD to be reduced to 21,639 mg · L⁻¹ to achieve an organic loading rate (OLR) of 17.1 kg COD · m⁻³ from an initial OLR of 229 kg COD · m⁻³.

The waste generated consists of mainly water, ammonia and biomass. It was decided that 30 % of the waste is purged and the remaining 70 % is recycled. Eventhough a large portion of waste is recycled, increasing the volume of the digester, the recycle is needed for the microorganism to easily adapt and for the continuous nurturing of new microorganisms in the system. The COD in the waste stream is 8.3 mg · L⁻¹ from an initial COD of 21.6 mg · L⁻¹

which a 62.5 % COD reduction. This goes above the expected performance of an anaerobic digester which usually have a reduction of COD of (40 to 60) % [11].

The purification of biogas was done by using a water absorbing column to remove carbon dioxide and hydrogen sulfide. The absorbing column was designed, within the SuperPro software, to remove 99 % of both carbon dioxide and hydrogen sulfide. In practicality, hydrogen sulfide can be removed 100 % whilst carbon dioxide exist in traces amount after purification, usually 0.2 % to 0.5 % [6, 12]. The biogas composition after purification is 95.54 % CH₄, 0.07 % H₂S and 4.38 % CO₂ by mass basis. The amount of water needed was optimised to the minimum amount that is required in the column. Less water supplied will reduce the efficiency of the column and the simulation will not run. Excess water provided will incur cost of raw water supply and the stripping of gas from water after the absorption process. The composition of biogas after purification is shown in Table 10.

Table 10. Composition of final product after purification

Component	Flow rate (kg · h ⁻¹)	Mass composition (%)	Concentration (g · L ⁻¹)
Carbon dioxide	14.57	4.38	0.02
Hydrogen sulfide	0.23	0.06	4.71 × 10 ⁻³
Methane	317.82	95.55	0.64

Total mass flow is 332.63 kg · h⁻¹ (equivalent to 429.94 m³ · h⁻¹) at temperature of 25 °C and pressure of 1.013 bar

3.2. Cost analysis

The economic analysis can be seen through generating economic evaluation report and the cash flow analysis report.

Table 11. Executive summary of economic evaluation report

Component	Value
Total capital investment	RM 25 691 000
Capital investment charged to this project	RM 25 691 000
Operating cost	RM 11 349 000
Revenues	RM 12 883 000/yr
Cost basis annual rate	2 576 683.27 kg MP/yr
Unit production cost	RM 4.40 /kg MP
Unit production revenue	RM 5.00 /kg MP
Gross margin	11.91 %
Return on investment	12.17 %
Payback time	8.22 yr
IRR (after taxes)	9.61 %
NPV (at 6.0 % interest)	RM 6 824 000

MP = Total flow of stream "final product"

RM = MYR = Malaysian Ringgit (1 MYR ~ USD 0,31. Oct 13,2014)

As seen on Table 11, the profit margin is 11.9 % which will give a rate of return on investment of 12.2 %, which will give the payback years of 8.2. This means only after 8.2 yr that the plant is actually making profit. Within the 8.2 yr, all profits are to payback the initial capital investment and the operating cost. The revenue is generated by the price of electricity generated for each kilogram of methane in the biogas, assuming that the gas is used to generate electricity. The calculation for the price of biogas per kilogram based upon how much electricity is generated with each kilogram of methane.

The operating costs breakdown in shown in Table 12. A large portion of the operating cost goes to the facility-dependent cost. Facility-dependent cost shows how much cost that is incurred to run the facilities without including the labor, utilities and consummables. The labor cost is averaged to RM50 per hour without specifying the total number of personnel or the total labor required. This is to simplify the calculation of cost for labor since the cost of labor is highly variable based on the working capital and the technical knowledge that is needed for the initiation, operation and maintenance of the plant.

Table 12 shows the annual operating costs of the current model. The cost of utilities such as water and electricity are based on the price that is set by providing companies which in this case are Syarikat Bekalan Air Selangor Sate

of Malaysia and Tenaga Nasional Berhad for water and electricity, respectively. The cost of heating agent which is steam was determined by the software database. Since the database is based on the prices in the United States of America, the price was converted to ringgit Malaysia (RM). This was done due to insufficient data acquired on the prices of heating element in the industries in Malaysia.

Table 12. Annual operating costs

Cost Item	USD	%
Raw materials	5 578 000	49.15
Labor-dependent	990 000	8.72
Facility-dependent	3 493 000	30.78
Water treatment/disposal	1 062 000	9.36
Utilities	225 000	1.98
Total	11 349 000	100

4. Conclusion

Simulation study on the biogas production via anaerobic digestion of fruit and vegetable wastes was successfully carried out by using SuperPro Designer v8.5. The anaerobic digester had a hydraulic retention time of 25 d and operated at 35 °C which was at mesophilic conditions. From the simulation, it can be observed that a total of 936.76 m³ · h⁻¹ of biogas is produced from a feed rate of 83.79 m³ · h⁻¹. The COD reduction of over 60 % proved that this system is an efficiency system for waste treatment because it exceeds the expected range of COD reduction of 40 % to 60 %. The purification unit which is the absorption column proved capable of removing 99 % of carbon dioxide and hydrogen sulfide in the simulation. This purified the biogas up to 95 % methane by mass basis. This high purity will increase the value of biogas and there can be more options for the utilization of the biogas. For the cost analysis, it is safe to imply that this biogas plant is economically feasible. The total capital investment in excess of RM25 million which included the working capital of RM3 million might prove to be an obstacle, however with a profit margin of 11 % and a return rate of investment of 12 % may just be lucrative enough for the company after the 8.2 yr payback time.

Acknowledgements

The authors would like to express the gratitude to Kulliyah of Engineering IIUM for supporting this project under FYP Fund and to Ministry of Education (MOE) of Malaysia under KTP Fund (No. KTP12-001-0001).

References

- [1] Agamuthu P. Challenges and opportunities in agrowaste management: An Asian perspective. Inaugural Meeting of First Regional 3R Forum in Asia. Tokyo, Japan. 2009.
- [2] Krich K, Augenstein D, Batmale J, Benemann J, Rutledge B, Salour D. (2005). A source book for the production and use of renewable natural gas in California. Biomethane from dairy waste 2005; p 29–67.
- [3] Jorgensen PJ. Biogas: Green Energy. 2nd edition. Plant Energy and Researcher for a Day. Faculty of Agricultural Sciences, Aarhus University. 2009.
- [4] Seadi TA, Rutz D, Prassl H, et al. Biogas handbook. University of Southern Denmark Esbjerg, Denmark; 2008. p. 41.
- [5] Drosig B, Al Saedi T, Braun R, Bochmann G. Analysis and characterisation of biogas feedstocks. In: Wellinger A, Murphy JD, Baxter D, editors. The biogas handbook: science, production and applications. Cambridge, UK: Woodhead Publishing Limited; 2013.
- [6] Grande C. Biogas upgrading by pressure swing adsorption. Biofuel's Engineering Process Technology 2011; p. 307–480.
- [7] Yu L, Wensel PC, Ma J, Chen S. Mathematical modelling in anaerobic digestion (AD). J Bioremed Biodeg 2013; S4:003
- [8] Ounnara A, Benhabylesa L, Igoud S. Energetic valorization of biomethane produced from cow-dung. In: Hacene M, Nachida KM, Nawel S, editors. The First International Seminar on Water, Energy and Environment. Procedia Engineering 2012; 33: 330–334.
- [9] Angelidaki I, Sanders W. Assessment of the anaerobic biodegradability of macropollutants. Reviews In Environmental Science & BioTechnology 2004; 3(2):117– 129.
- [10] Babae A, and Shayegan J. Effect of organic loading rates (OLR) on production of methane from anaerobic digestion of vegetables waste. Bioenergy Technology 2011;5(32):98–101.
- [11] Ursula K, and Odd ES. Thermo dynamical assessment of the digestion process. CIWEM/Aqua Enviro 5th European Biosolids and Organic Residuals Conference November 2000, Cedar Court, Wakefield, UK

- [12] De Brito MH. Gas absorption experiments in a pilot plant column with sulzer structured packing mellapak. [Thesis] Ecole Polytechnique Fédérale de Lausanne, Switzerland. 1991.