

Proceedings

Third Annual Paper Meet

31 Oct - 02 Nov, 1996, Chittagong

THE INSTITUTION OF ENGINEERS, BANGLADESH



APM '96

Organised by

The Institution of Engineers, Bangladesh, Chittagong Centre and
Mechanical Engineering Division

A CASE STUDY ON DESIGN AND MANUFACTURE OF TILTING PAD THRUST BEARING FOR STEAM TURBINE OF FERTILIZER FACTORIES

Dr. A.K.M.N. Amin,
IPE Department, BUET, Dhaka - 1000, Bangladesh
M.M. Rahman and M.M. Hossain
ME Department, BUET, Dhaka - 1000, Bangladesh

Abstract:

Bangladesh has to depend mainly on imported spare parts for maintenance of its major industries. The picture is not different in the case of the fertilizer factories. Tilting pad thrust bearing is a critical and very expensive spare part of fertilizer factories. Like many other spares this spare has to be imported because it is not locally manufactured. The country is losing a huge amount of foreign currency in importing this and other spare parts. Apart from the high procurement cost import involves long lead time. In order to avoid factory shut downs a lot of spares are also kept in reserve. This leads to very high inventory costs which results in high factory overhead costs. As an attempt to solve these problems the present study was under taken. The main objective of the work was to ascertain whether local manufacture of a critical spare parts like tilting pad thrust bearing was at all feasible. Design and manufacture of the above mentioned bearing were performed under the present case study. Tests were performed to identify the material of the bearing lobes as well as the composition of the of the white metal layer. Since no working or detail drawing of the part was available in the factory, the different dimensions of the spare part were determined by precision measurements and by analytical methods. Apart from that the sequence of manufacturing operations were so designed as to permit its manufacturing using local facilities. Fixtures required for maintaining the required precision of manufacturing were designed appropriately. The part was subsequently manufactured using technical facilities of BUET and BITAC. The lobes were precisely machined and then white metalling was performed. The bearing lobes were then ground and polished to accurate dimensions. Finally the jobs were checked for quality and are ready for practical tests.

1.0 Introduction:

The agriculture sector plays the most vital role in the economy of our country. It contributes more than 50% to the total GDP of Bangladesh. The present Government has laid special attention to boost up production in this sector. Huge amount of money has been and being invested in agro-support and agro-based industries of Bangladesh.

Fertilizer is the most important element which enhances the agricultural production. So priority has been given to build up fertilizer industry because its contribution to production is quite high. At present there are eight fertilizer factories in our country.

Though theoretical contribution shown by the fertilizer factories are satisfactorily high, yet in reality the contribution is relatively poor. One of the major causes of for this poor contribution is due the low capacity utilization of the machineries and equipment. By all accounts, it seems that fertilizer factories are suffering from an overload of extra price. It has been found that if the machineries could be maintained using locally manufacture spare parts the cost of production of fertilizers would have been lower.

Five years back a study was undertaken on the experimental manufacture of spare parts for Urea Fertilizer Factory, Ghorashal Ltd. Tilting pad thrust bearing, which is a very expensive spare part, has been selected for test manufacturing. This challenging project has been executed for the last four years by nine final year students of Mechanical Engineering under the supervision of the first author. Different parts of tilting pad thrust bearing have been designed and manufactured by different groups students. The second and the third authors had the opportunity to finalize the project work.

2.0 Raw Material of the part:

The material of the imported parts tilting pad thrust bearing was found to be chromium steel with 12% of chromium. The part was found in the annealed condition. Chromium is in the form of simply carbides (CrC_3 , Cr_4C) or complex carbides (FeCr_3C) these carbides have high hardness and good wear resistance, the corrosion resistance property is due to a thin adherent stable chromium oxide film that effectively protect the steel against many corroding media. This is occurs only when the chromium content exceeds about 10%. Chromium is soluble up to about 13% in iron.

3.0 Design Procedure of Tilting Pad Trust Bearing:

The bearing consists of eight lobes, held around the circumstances of the pad. The detail drawing of the lobe is shown in Fig.1. The following article gives the description of the design procedure of such a bearing lobe. The bottom surface of the part is not parallel with the horizontal plane. One side is slightly protruded with respect to the other side. so if the bottom surface of the part is made parallel with horizontal plane, it would cause some error in calculation, though it would make further calculations easier.

3.1 Determination of the Inclination Angle:

The inclination angle at different sections of the part was found to be different. So several sections on the part were considered. Chord length for each section and vertical heights of both ends of the chord from base were measured (Fig.2).

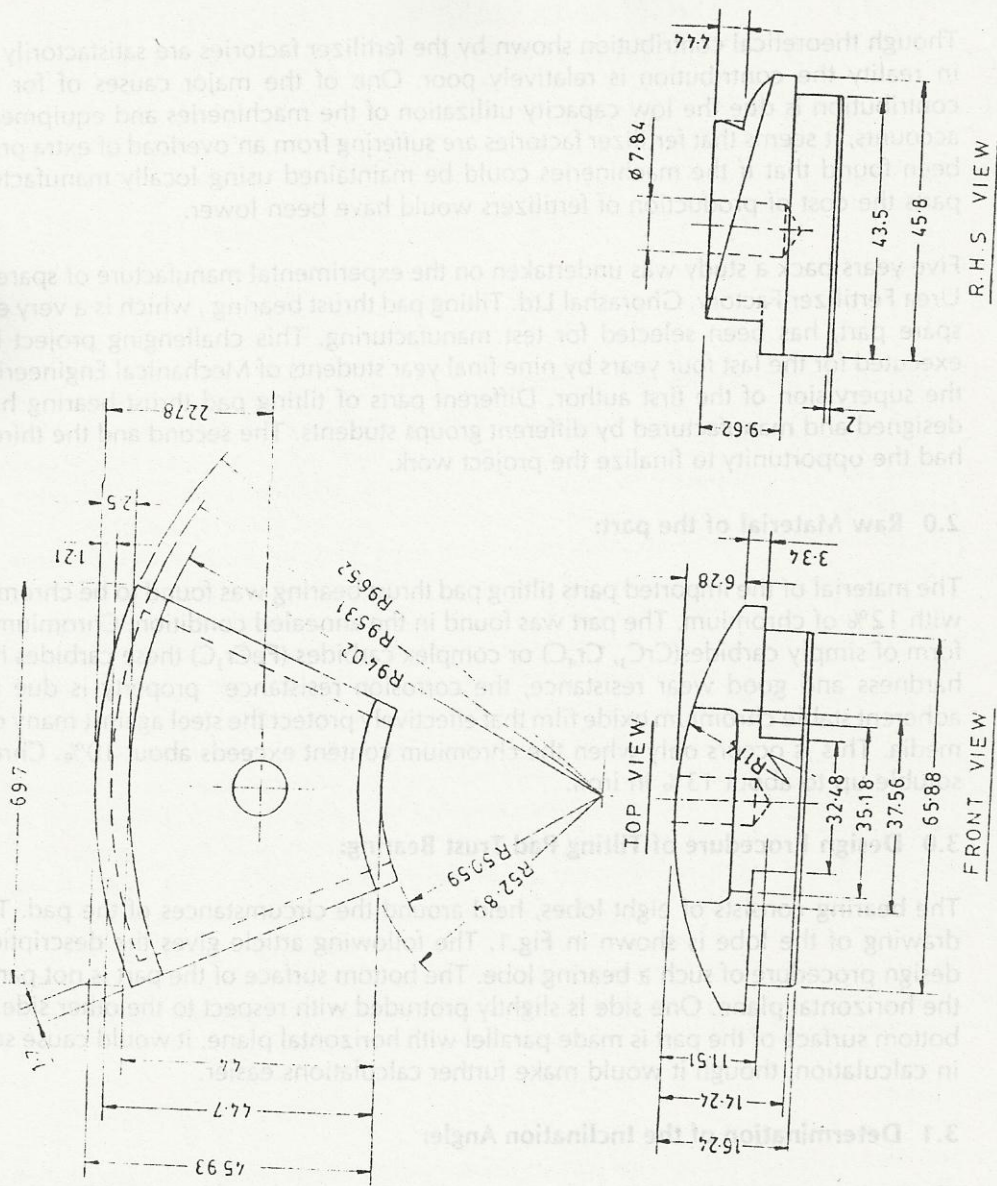

Fig. 1 Detail drawing of the tilting pad thrust bearing lobe

Fertilizer is the most important element which enhances the agricultural production. It has been given to build up fertilizer industry because its contribution to production is quite high. At present there are eight fertilizer factories in our country.

Through the study shown by the fertilizer factories are satisfactory high yield. The production is relatively poor. One of the major causes for this poor capacity utilization of the machines and equipment. By all the fertilizer factories are suffering from an overload of extra work. It has been found that the machines could be maintained using locally manufacture spare parts. The cost of fertilizers would have been lower.

The study was undertaken on the experimental manufacture of spare parts for fertilizer factories. The study was conducted by the first author. The study was conducted for test manufacturing. This Challenging project has been executed for four years by nine final year students of Mechanical Engineering under the supervision of the first author. Different parts of the bearing lobe were designed and manufactured by different groups of students. The first author had the opportunity to finalize the project work.

1.0 Raw Material of the part:

The material used for the tilting pad thrust bearing lobe is Chromium steel with 1.2% Carbon. The part was found in the form of a blank. Chromium steel is a hard and strong material. It is used for making of parts which have high strength and wear resistance. The bearing lobe is a part of the bearing assembly. It is used to support the shaft and to transmit the load. The bearing lobe is a curved part. It is used to support the shaft and to transmit the load. The bearing lobe is a curved part. It is used to support the shaft and to transmit the load.

3.1 Determination of the Inclination Angle:

The inclination angle at different sections of the part was found to be different. So several sections on the part were considered. Chord length for each section and vertical height of both ends of the chord from base were measured (Fig. 2).

Table-5: Calculation of back angle of the arc lobe

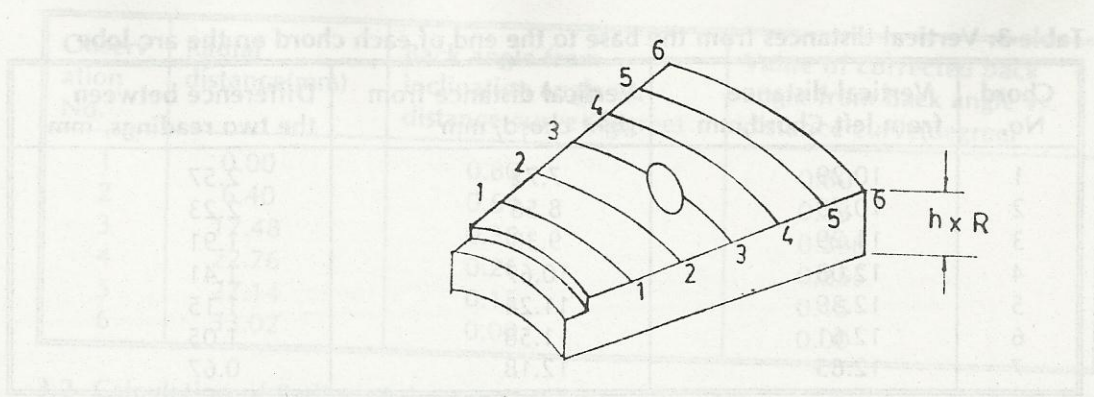

Fig 2 Determination of the inclination angle

Lengths of different chords are listed in Table-1.

Table-1: Chord length at different sections of the bearing lobe

No. of obs.	Chord no.	Chord Length(mm)
1	1	68.20
2	2	63.80
3	3	58.80
4	4	50.80
5	5	47.00
6	6	44.30
7	7	39.80

Table-2: Radial distance between two adjacent chord marked on the arc lobe

No. of observation	Distance on the left side, mm	Distance on the right side, mm	Average distance, mm
1	5.76	5.76	5.76
2	6.40	6.39	6.305
3	11.08	12.02	11.55
4	5.28	5.27	5.275
5	4.38	4.55	4.465
6	5.88	6.75	6.315

Table-3: Vertical distances from the base to the end of each chord on the arc lobe

Chord No.	Vertical distance from left Chord,mm	Vertical distance from right chord, mm	Difference between the two readings, mm
1	10.29	7.72	2.57
2	10.79	8.56	2.23
3	11.29	9.38	1.91
4	12.08	10.67	1.41
5	12.39	11.24	1.15
6	12.61	11.58	1.05
7	12.85	12.18	0.67

- α = Inclination angle
 b = Chord length
 a = Difference in vertical distance
 = $h_L - h_R$

where,

- h_L = Vertical height from the base to the left side end of chord
 h_R = Vertical height from the base in the right side end the chord

Table-4: Calculated values of inclination angle of the arc lobe

Chord No.	Inclination angle, α in degrees
1	2.1587
2	1.999
3	1.8592
4	1.603
5	1.401
6	1.3645
7	0.9633

Since the surface of the job is a part of a cylindrical shaft so the inclination angle versus radial distance plot (from first chord) should give a straight line relationship. Using least square method, the true straight line relationship is obtained.

The back angle of the bottom surface of the part should be taken in to account for design purpose. Values of back angle are taken from inclination angle versus radial distance curve. Using least square method another graph was plotted. Back angle versus distance from which corrected values are noted down in Table-6.

Table-5: Calculation of back angle of the arc lobe

Observation No.	Radial distance(mm)	Back angle from inclination angle vs. distance curve (degree)	Value of corrected back angle from back angle vs. distance curve(degree)
1	0.00	0.80	0.80
2	6.40	0.64	0.53
3	17.48	0.38	0.388
4	22.76	0.26	0.255
5	27.14	0.15	0.15
6	33.02	0.00	0.00

3.2 Calculation of Radius of the Top Curved Surface of the Arc Lobe:

The radius of the top curved surface of the part can be calculated as follows:
From triangle AOB (Fig.3)

$$\begin{aligned}
 AO^2 &= OB^2 + AB^2 \\
 AO^2 &= (OC - BC)^2 + AB^2 \\
 &= OC^2 - 2C.BC + BC^2 + AB^2 \\
 AO^2 &= AO^2 - 2OC.BC + AB^2 + BC^2 \\
 2AO.BC &= AB^2 + BC^2 \\
 AO &= (AB^2 + BC^2)/2BC
 \end{aligned}$$

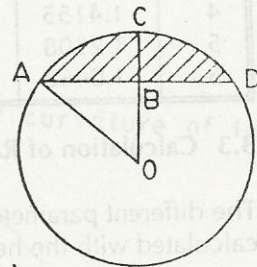

3a)

Here,

- AO = Radius of the spherical surface, R
- AB = Half of the chord length, AD
- BC = Radial distance between the outer circumference and the middle point of the chord.

From Fig.3 it is clear that when the right side of the part is raised by an angle to α , then the actual radial distance between the outer circumference and the middle point of the chord can be obtained with reasonable accuracy. So a correction term is to be added while calculating the radial distance between the outer circumference and the middle point of the chord. Considering that the right side of the part is raised by an amount equal to h. For small angle α , the correction will be h:

$$\begin{aligned}
 \sin \alpha &= h/c \\
 h &= c \times \sin \alpha
 \end{aligned}$$

Where,

- α = Angle of inclination
- b = Chord length

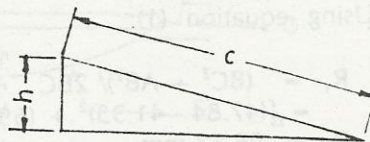

3b)

Fig.3 Calculation of the radius of the top curve

For design purpose an average radius should be taken which can be found as follows:

$$R_{JV} = \Sigma R/6 = 113.92 \text{ mm}$$

By rounding off the average radius may be accepted as 114 mm.

Table-6: Parameters for calculation of the radius of the top curve surface of the arc lobe

No. of Obs	h (mm)	h/2 (mm)	BC radial distance between circumference and middle point of chord(mm)	Radius R (mm)
1	2.5697	1.2848	5.2248	111.83
2	2.292	1.146	4.5546	114.27
3	1.7866	0.8933	3.8333	114.83
4	1.4155	0.7077	2.8577	112.45
5	1.2308	0.4554	4.4319	113.78
6	1.0462	0.5231	2.1413	114.40

3.3 Calculation of Radius of Curvature of Outside an Inside Curved Surface

The different parameters of the bearing lobe are shown in Fig.4. For simplicity radius R_1 is calculated with the help of the following equations:

$$R_1 = (BC^2 + AB^2)/2BC \dots\dots\dots(1)$$

$$R_2 = R_1 - a \dots\dots\dots(2)$$

$$R_3 = R_1 - c \dots\dots\dots(3)$$

$$R_4 = R_1 - e + b \dots\dots\dots(4)$$

$$R_4 = R_1 - e \dots\dots\dots(5)$$

Where the dimensions are :

$$\begin{aligned} a &= 1.70 \text{ mm} & b &= 2.25 \text{ mm} \\ c &= 2.50 \text{ mm} & g &= 1.21 \text{ mm} \\ e &= 45.53 \text{ mm} \end{aligned}$$

Using equation (1):

$$\begin{aligned} R_1 &= (BC^2 + AB^2)/ 2BC \\ &= \{(47.84 - 41.35)^2 + (69.59/2)^2\}/2(47.84 - 41.35) \\ R_1 &= 96.52 \text{ mm} \end{aligned}$$

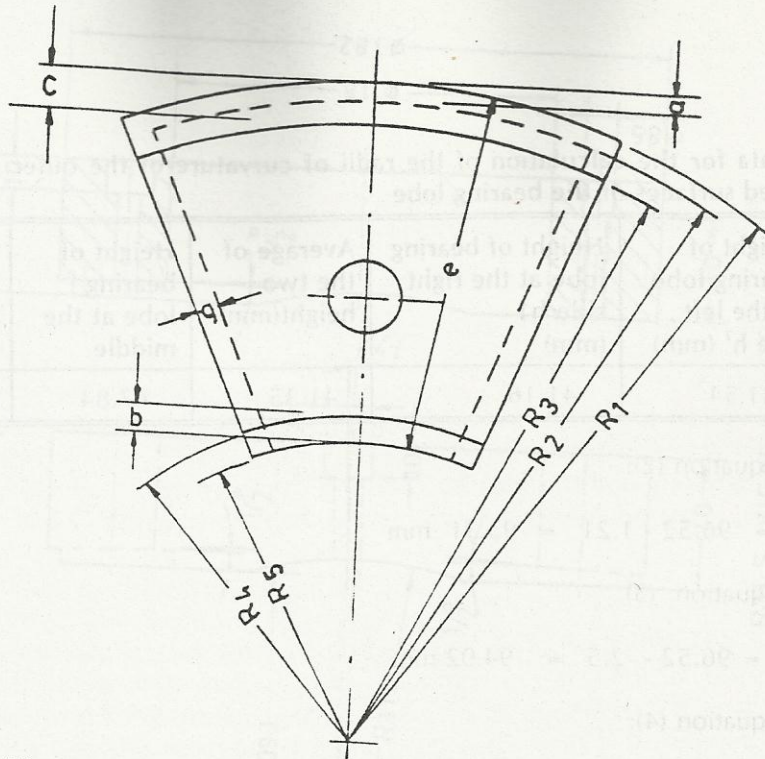

Fig.4 Dimensions of radius of curvature of lobes

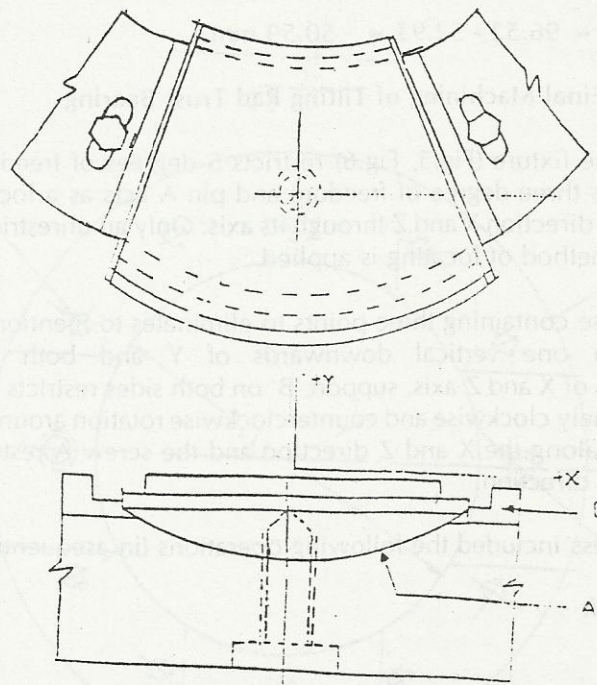

Fig.5 Holding of tilting pad thrust bearing for final machining

Table 8: Data for the calculation of the radii of curvature of the outer and the inner curved surfaces of the bearing lobe.

No. of obs	Height of bearing lobe of the left side h^2 (mm)	Height of bearing lobe at the right side h_1 (mm)	Average of the two height (mm)	Height of bearing lobe at the middle	Chord length (mm)
1	41.54	41.16	41.35	47.84	69.59

Using equation (2):

$$R_2 = 96.52 - 1.21 = 95.31 \text{ mm}$$

Using equation (3):

$$R_3 = 96.52 - 2.5 = 94.02 \text{ mm}$$

Using equation (4):

$$R_4 = 96.52 - 45.93 + 2.25 = 52.84 \text{ mm}$$

Using equation (5):

$$R_5 = R_1 - ee = 96.52 - 52.93 = 50.59 \text{ mm}$$

3.4 Fixture Design for Final Machining of Tilting Pad Trust Bearing

The curved surface of the fixture (Fig.5, Fig.6) restricts 5 degrees of freedom, the surface parallel to z axis restricts three degree of freedom and pin A acts as a locator as well as eliminates movements in direction X and Z through its axis. Only an unrestricted movement of a pin a. Thus 3-2-1 method of locating is applied.

The machining curve base containing three points to eliminates to mention in 5 degree of freedom, consisting on one vertical downwards of Y and both clockwise and counterclockwise motion of X and Z axis, support 'B' on both sides restricts three additional degrees of freedom's namely clockwise and counterclockwise rotation around the Y axis and linear horizontal motion along the X and Z direction and the screw A restrict 1 degree of linear motion along + Y direction.

The manufacturing process included the following operations (in asequential manner):

1. Parting of the shaft
2. Facing
3. Through drilling
4. Boring

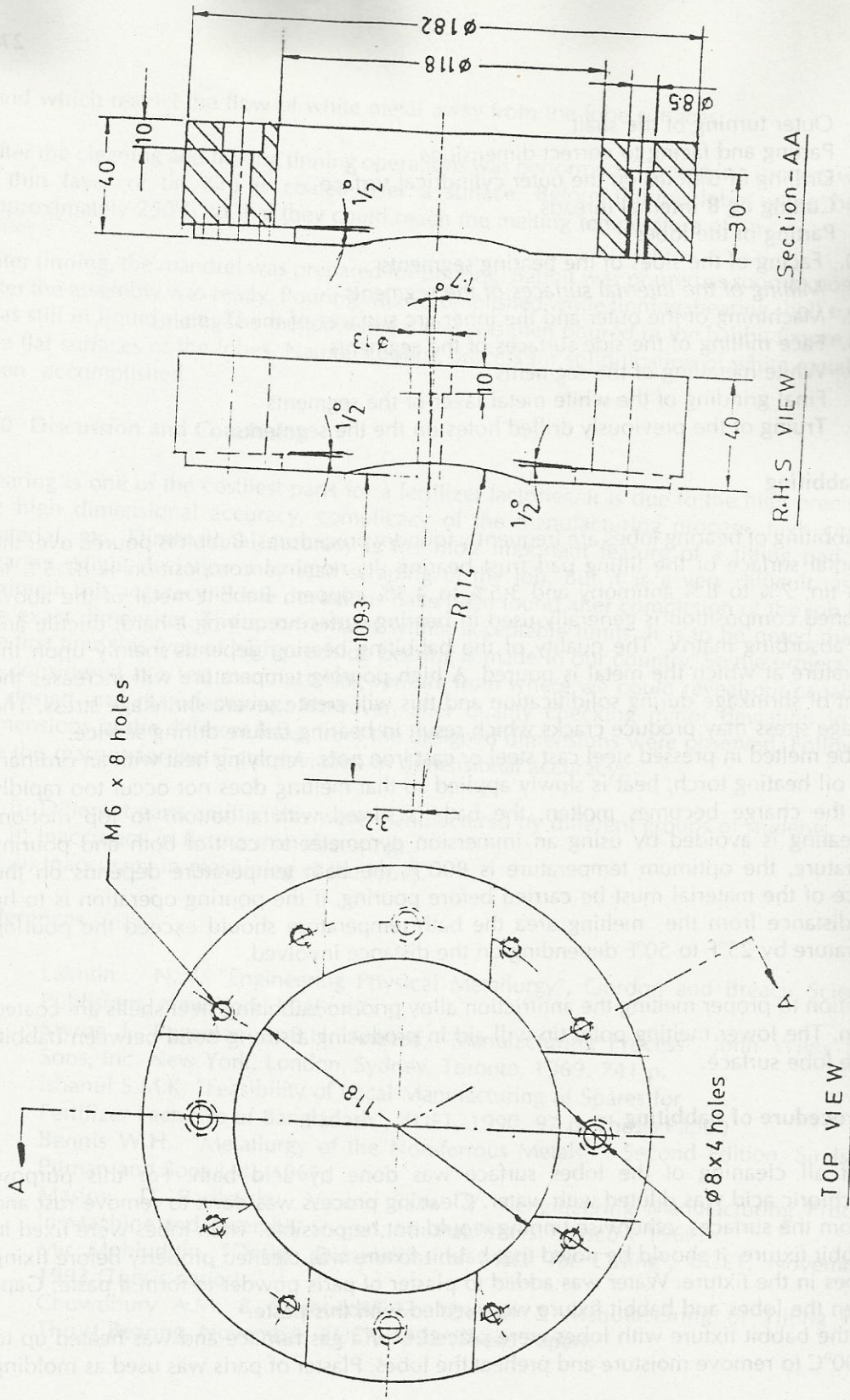

Fig.6 Fixture design for tilting pad thrust bearing
Part . 1

5. Outer turning of the shaft
6. Parting and facing to correct dimensions
7. Drilling of 8 holes on the outer cylindrical surface
8. Cutting of 8 internal threads
9. Parting of the lobes
10. Facing of the sides of the bearing segments
11. Milling of the internal surfaces of the segments
12. Machining of the outer and the inner arc surfaces of the segments
13. Face milling of the side surfaces of the segments
14. White metallizing of the segments
15. Final grinding of the white metal layer of the segments
16. Truing of the previously drilled holes on the the segments

4.0 Babbiting

The babbiting of bearing lobes are frequently foundry procedures. Babbitt is poured over the horizontal surface of the tilting pad trust bearing. Its nominal composition is 87.5% to 89.5% tin, 7% to 8% antimony and 3.5% to 4.5% copper., Babbitt metal of the above mentioned composition is generally used in bearing surface requiring a hard, ductile and shock absorbing matrix. The quality of the babbiting bearing depends mainly upon the temperature at which the metal is poured. A high pouring temperature will increase the amount of shrinkage during solidification and this will create severe shrinkage stress. The shrinkage stress may produce cracks which result in bearing failure during service.

It can be melted in pressed steel cast steel or cast iron pots. Applying heat with an ordinary gas or oil heating torch, heat is slowly applied so that melting does not occur too rapidly when the charge becomes molten, the bath is stirred with a bottom to top motion. Overheating is avoided by using an immersion pyrometer to control both and pouring temperature, the optimum temperature is 800°F, the bath temperature depends on the distance of the material must be carried before pouring, if the pouring operation is to be some distance from the melting area the bath temperature should exceed the pouring temperature by 25°F to 50°F depending on the distance involved.

In addition to proper melting the antifriction alloy prior to babbiting steel shells are coated with tin. The lower melting point tin will aid in producing a strong bond between babbitt and the lobe surface.

4.1 Procedure of Babbiting

First of all cleaning of the lobes surface was done by acid bath. For this purpose Hydrochloric acid was diluted with water. Cleaning process was done to remove rust and dust from the surfaces, otherwise tinning would not be possible. Then lobes were fixed in the babbitt fixture. It should be noted that babbitt fixture was cleaned properly before fixing the lobes in the fixture. Water was added to plaster of paris powder to form a paste. Gaps between the lobes and babbitt fixture were sealed with this paste. Then the babbitt fixture with lobes were placed over a gas furnace and was heated up to 200-300°C to remove moisture and preheat the lobes. Plaster of paris was used as molding

sand which restrict the flow of white metal away from the lobe surfaces.

After the cleaning and fluxing tinning operations was performed. Tinning is a process where a thin layer of tin (Sn) is coated over a surface. Before tinning lobes were heated approximately 250°C so that they could reach the melting temperature of tin.

After tinning, the mandrel was prepared for pouring. Babbit was poured as soon as possible after the assembly was ready. Pouring was accomplished while tinning, bearing shell surface was still in liquid state. The melted white metal was then poured in the babbit fixture over the flat surfaces of the lobes. Natural cooling process for solidification of white metal was then accomplished.

5.0 Discussion and Conclusion

Bearing is one of the costliest parts for a fertilizer factories. It is due to the high precision, i.e high dimensional accuracy, complicity of the manufacturing process, high cost of material, etc. Dimensional accuracy is the most important feature of a tilting pad trust bearing. Slight deviation may lead scraping of the job. But it is a very difficult task to maintain this accuracy. Some deviations have been found after completion of the job from the exact dimension. The error remains within acceptable limits. It is to be noted that for the first time this type of high precision bearing is made in our country. So the project may be considered as a test manufacturing venture from where we could reveal our capability in design and manufacturing. However, after quality checking minor deviation in the dimensions of the different lobes from the designed dimensions were observed. Following are the reasons for the slight deviation in dimensional accuracy:

- i) Different parts and fixtures were manufactured by different groups of students.
- ii) Inaccuracy in fixture manufacturing
- iii) Inaccuracy in machining of the lobes.

References

1. Lakhtin N.,Y. "Engineering Physical Metallurgy", Gordon and Breach Science Publishers, New York, 1965. 471 p.
2. Myron L. Begeman & B.H. Amsted, "Manufacturing Process", John Wiley and Sons, Inc. New York, London, Sydney, Toronto, 1969. 741 p.
3. Ishanul S.M.K, "Feasibility of Local Manufacturing of Spares for Fertilizer Factories of Bangladesh", BUET, 1990, 97 p.(Thesis Paper)
4. Bennis W.H., "Metallurgy of the Non-ferrous Metals," Second Edition, Sir Isaac Pitman and Sons Ltd., 1961
5. Maslov D. Barilevsky V. and Saav V., "Engineering Manufacturing Process in Machine and Assembly Shops", Mir Publishers, Moscow 1967.
6. Mir Mohiuddin, "Design Dimensions of Metal for Casing", BUET, November, 1993 (Thesis paper).
7. Chowdhury A.M. & Salahuddin M. "Design & Manufacturing of Tilting Pad Thrust Bearing, November, BUET, 1993 (Thesis Paper).