

Emergency Medical Care Information System for Fetal Monitoring

Muhammad I Ibrahimy

International Islamic University Malaysia, Kuala Lumpur, Malaysia

Abstract

This paper presents a research work that is concerned to implement an emergency medical care information system for fetal ECG (FECG) monitoring. The research work comprises of three major parts i.e. development of an abdominal ECG (AECG) data acquisition system, networking of transferring and receiving AECG data between patient (client) and physician (server), and improvement of existing techniques for fetal heart rate (FHR) monitoring. The main function of AECG data acquisition system is to acquire the mothers ECG data using a commercial chip called CARDIC and store it in a local terminal. On the other hand, the networking application serves the purpose of transferring the AECG data to the remote terminal via the established connection for remote monitoring and diagnosis purpose. Eventually, the AECG signals are processed in the remote terminal to extract the FECG from the AECG signal for efficient FHR monitoring. The networking system is a client/server application known respectively as Local Patient Monitoring System (LPMS) and Remote Patient Monitoring System (RPMS). It supports transferring of AECG data file and online chatting session. The diagnoses of the reading will be done by the specialists and action can immediately be taken in emergency cases.

1. Introduction

Telemedicine provides a great impact in the emergency monitoring of patients located in remote nonclinical environments. Pregnant women who have been identified, as being at risk of stillbirth due to FECG decelerations should be using a FECG monitor during maternal sleep, the time when most stillborn deaths occur [1-3]. Because the mother's blood pressure is lowest during this period, and cord compression is more likely when the woman is lying down - especially in late term when there is little room for the baby to move - a monitor may have the potential to detect any dangerous fluctuation or decline in the baby's ECG in time to allow for appropriate medical intervention. To monitor such abnormalities, compact, portable, long term monitoring has been proven to be mainstay of fetal surveillance during pregnancy [4]. Connected to the Internet through a laptop computer, the

monitor will be capable of sending an alert to a woman's physician.

2. Method and methodology

This research has been divided into three parts such as constructing a compact portable electronic CARDDIC based ECG data acquisition system, developing the network of transferring and receiving ECG signals and improving the accuracy of existing techniques for automatic analysis of the above signal for FHR monitoring. The overall flow of the research work is shown in Figure 1.

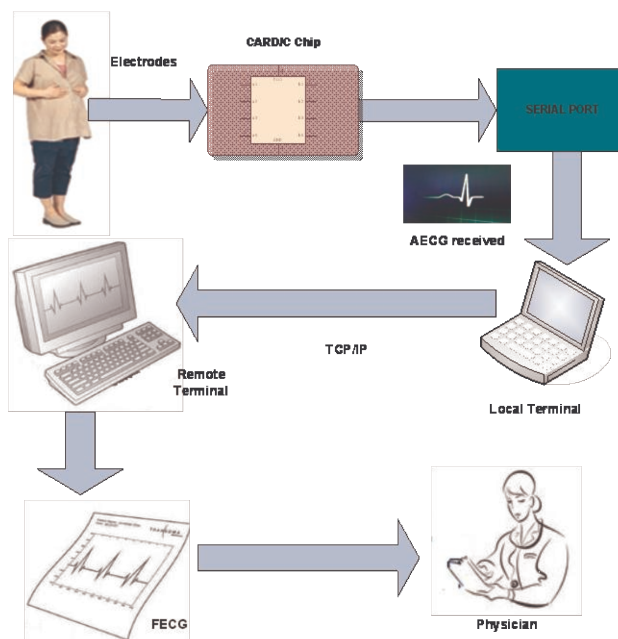

Figure 1. Overall flow chart.

2.1. Data acquisition system

The function of this data acquisition system is to provide AECG data to a local computer via RS232 serial port. The system is based on CARDIC ECG module; a commercial ECG front-end ASIC hardware. The system consists of microcontroller module, the mentioned ECG

front-end module and RS232 opto-isolator module is shown in Figure 2.

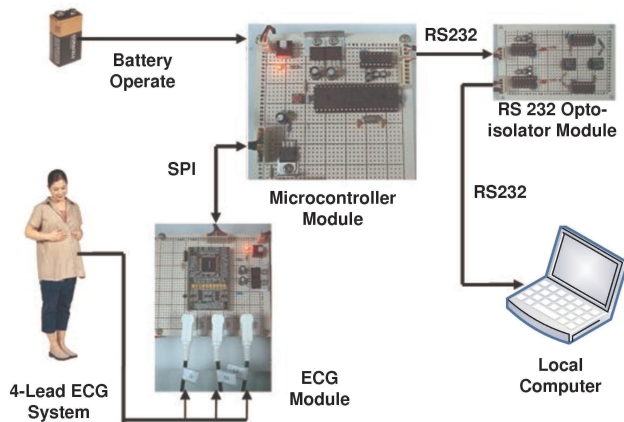

Figure 2. AECG data acquisition system.

The system activity is started with the microcontroller enquires the AECG data from ECG module via SPI bus. As a response the AECG data is sent to the microcontroller by ECG module also via SPI bus. Next the microcontroller sends the received data to a local computer via RS232 opto-isolator module. The total acquisition system is developed in a single PCB module is as shown in Figure 3 and the system specifications are shown in Table 1.



Figure 3. A single PCB module of PC based 4-lead ECG hardware system.

Table 1. System specifications.

1	Sampling rate	500 sample per second
2	ECG leads system	4-lead
3	ECG data width	12-bit signed data
4	Electrical isolation	RS232 with opto-isolation
5	Power source	9 Volt battery operated
6	ECG front-end analog system	Commercial ECG - CARDIC

2.2. Networking

The networking part is in the form of a Visual Basic based client/server pair application. The client and server application is installed in local and remote terminal respectively. The networking program is established a connection between local and remote terminal via TCP/IP to provide transfer of data and enable chat session.

TCP/IP provides a reliable, point-to-point communication channel that client-server application on the Internet use to communicate with each other. To communicate over TCP, a client program and a server program establish a connection to one another. Each program binds a socket to its end of the connection. To communicate, the client and the server each reads from and writes to the socket bound to the connection.

Data transmitted over the Internet is accompanied by addressing information that identifies the computer and the port for which it is destined. The computer is identified by its 32-bit IP address, which IP uses to deliver data to the right computer on the network. Ports are identified by a 16-bit number, which TCP and UDP use to deliver the data to the right application.

The networking program is manifested in the form of a client/server pair application. The client application is known as Local Patient Monitoring System (LPMS), which is installed in the local terminal. On the other hand, the server application, which is known as Remote Patient Monitoring System (RPMS), is installed in the remote terminal. Here, the terms of local terminal refers to the PC or workstation resides in the patient's residential area. Remote terminal refers to the PC or workstation resides in hospital that is separated with a geographical distance from the patient.

The send file module (in LPMS) and receive file module (RPMS) enables the transmission and reception of ECG data file via the networking established by the networking module are shown in Figure 4 and 5 respectively.

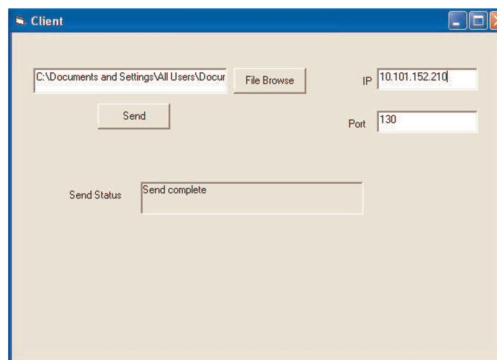

Figure 4. Sending file from client (LPMS).



Figure 5. Receiving file at server (RPMS).

The chat session module is intended to provide a mean of communication between the physician at RPMS and patient at LPMS are shown in Figure 6 and Figure 7 respectively so that it can be possible to provide important medical advice.



Figure 6. Chatting from server side (RPMS).

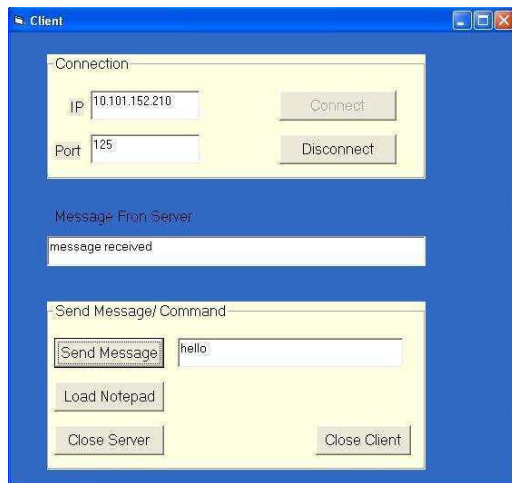

Figure 7. Chatting from client side (LPMS).

2.3. FECG extraction algorithm

The system is required to record the FHR by processing the AECG signal acquired from the abdomen of pregnant women. The algorithm is a crucial part of the recorder for processing the AECG to detect the fetal and maternal R peaks for measuring the FHR and maternal heart rate (MHR).

The algorithm has been developed based on digital filtering, adaptive thresholding, and statistical properties in the time domain. The AECG signal is obtained from the maternal abdomen and first passed through a finite impulse response band pass filter (cut-off frequencies of 10 and 40 Hz) to remove baseline drift. The algorithm then detects the maternal QRS complexes by thresholding the maximum value of the match filter output. A maternal ECG (MECG) template is formed from successfully detected maternal QRS complexes using the R peak as the fiducial point.

The digital filter's coefficients have been chosen to effectively pass the highest power density of the maternal and fetal R waves. The filtered signal has then been cross-correlated with an 80 ms averaged maternal QRS template, based on the normal width of the maternal QRS complex. An initial template resembling the QRS complex has been first used, and then continuously updated based on a running average of detected QRS complexes. The algorithm mainly contains various routines, the initialization, search for maternal R peak, update maternal template, search for maternal R peaks using updated template, validate and save the maternal RR interval, MECG template formation, subtract MECG template. Each sample data within these routines, notch filter, cross-correlation and local maximum search routines are performed.

The MECG template for subtraction is formed. The duration of this template is fixed, 160 ms before and 320 ms after the R peak instant, that the average MHR is less than 125 BPM and it can be easily include the maternal P and T waves, if any. First subtraction and MECG template formation are done simultaneously. The signal buffer are replaced by the MECG template which are initially set to zeros for the first subtraction of MECG complex by itself and the data samples associated the R peak. At the end of this routine, the samples of maternal QRS template are copied to the data memory of the maternal template section.

To check the coincidences of the maternal with the fetal R waves, four latest maternal RR intervals are maintained in the data memory. The subroutine also identifies the position based on the R peak position in the signal buffer for the start of the subtraction window. The update subroutine adapts the thresholds according to the signal and noise levels and compares the latest RR interval with the RR interval limits. The local maximum values are then set to zero for further R wave search. The

fetal R wave search interval is first set at 640 ms assuming that initially the FHR does not exceed 187 (BPM). The validation routine also checks for possible concurrence of the detected maximum with that of the maternal QRS complex.

3. Result and discussion

Figure 8 shows (one of the results) the heart rate traces of patient at 38 weeks of pregnancy. In this figure, the MHR and FHR traces are visible and continuous. According to the result it can be said that the MHR and FHR recording performance is almost 100 percent.

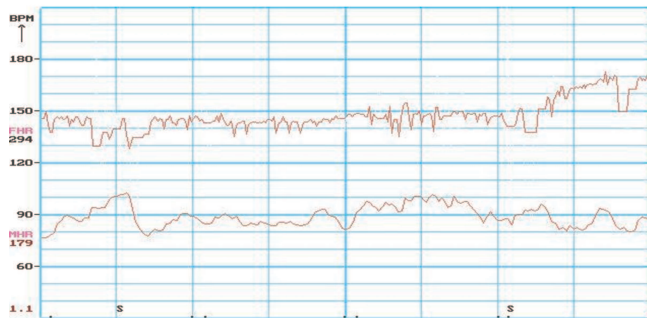
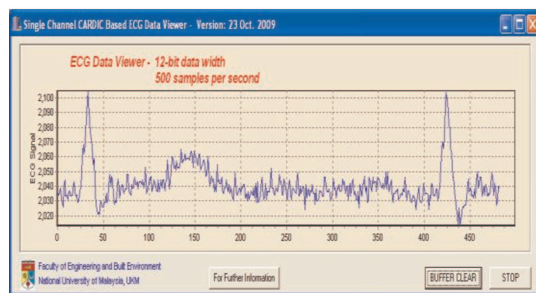

Figure 8. FHR (top) and MHR (bottom) traces from patient (week 38). The time scale is 0.5 min/division, Last four minutes of the recording.

4. Comparison

It has been compared the developed ECG acquisition system based on CARDIC chip with a commercial product BIOPAC Amplifier. A computer in conjunction with a software Acqknowledge was used for logging the ECG data from BIOPAC system. Simultaneous ECG signals obtained from the same subject were also downloaded from our system to the PC. It is clear from Figure 9 (a) and (b) that designed ECG acquiring system is having similar ECG signal like BIOPAC module. The signal has a low noise which can be removed easily. However, the developed system is compact, portable and suitable for long term monitoring.



(a) Using CARDIC chip.

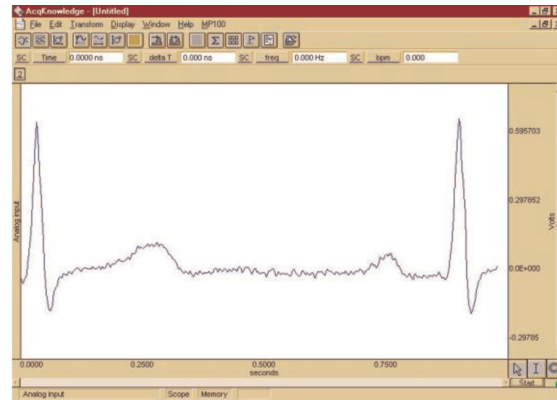

(b) Using BIOPAC module

Figure 9. ECG acquisition; a) using CARDIC chip, b) using BIOPAC module.

5. Conclusions

The performance of the system in determining the FHR depends upon the FECG signal, which is obtained by subtracting the average MECG from the AECG signal. If the complete elimination of MECG is possible then good performance for determination of FHR is achieved. It is seen that the performance of the system also depends upon the amplitude of FECG signal in the AECG signal. If the FECG is very small, less than 3 μ V, correct detection of the fetal R peaks would not be possible. The contamination of noise in the AECG signal is also important whilst match filtering was used to detect the QRS complexes. However, the algorithms have been developed to be able to resume correct detection when the signal to noise ratio improves. The developed algorithm can extract both maternal and fetal heart rates utilizing a single-lead configuration. TCP/IP provides a reliable, point-to-point communication channel that client-server application on the Internet is used to transfer AECG signal.

References

- [1] Collins J H MD. Umbilical cord accidents-Time of death? American J of Obs. & Gyn 1997: 177(6) pp. 1566.
- [2] Chu S Y, Kim S Y, Lau J et al. Maternal obesity and risk of stillbirth: a metaanalysis. American J of Obs. and Gyn 2002: 197(3) pp. 223-228.
- [3] Fifer W, Myers M. Sudden fetal and infant deaths: Shared characteristics and distinctive features. Seminars in Perinatology 2002: 26(1) pp. 89-96.
- [4] Hurk P R B der , Middelkoop H A M, Doorn E S C W et al. Long-term ambulatory monitoring of urine leakage in the elderly: An evaluation of the validity and clinical applicability of thermistor signalling. J of Med Eng. & Tech. 1998: 22(2) pp. 91-93.